

Three level inverter SiC MOSFET Power Module

SiC Power MOSFET :

$V_{DSS} = 1200V$; $R_{DS(on)} = 13m\Omega$ @ $T_j = 25^\circ C$

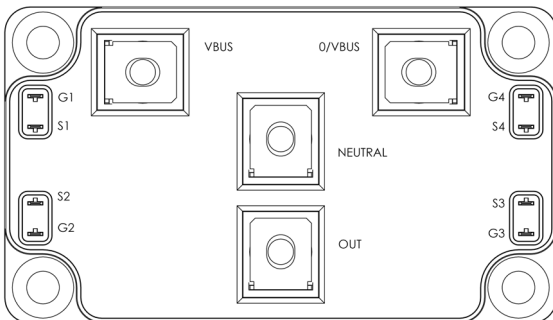
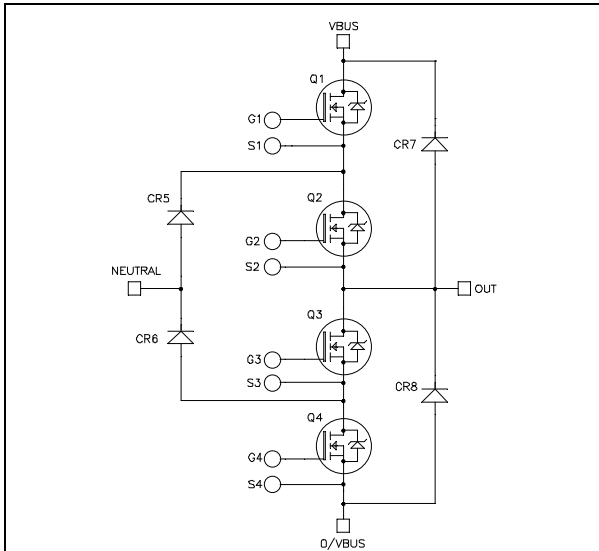

Application

- Uninterruptible Power Supplies

Features

- **SiC Power MOSFET**
 - Low $R_{DS(on)}$
 - High temperature performance
- **SiC Schottky Diode**
 - Zero reverse recovery
 - Zero forward recovery
 - Temperature Independent switching behavior
 - Positive temperature coefficient on VF
- Kelvin emitter for easy drive
- Very low stray inductance
- M5 power connectors
- High level of integration
- AlN substrate for improved thermal performance

Benefits

- Stable temperature behavior
- Very rugged
- Direct mounting to heatsink (isolated package)
- Low junction to case thermal resistance
- Easy paralleling due to positive TC of VCEsat
- Low profile
- RoHS Compliant

All ratings @ $T_j = 25^\circ C$ unless otherwise specified

Q1 to Q4 Absolute maximum ratings (per SiC MOSFET)

Symbol	Parameter	Max ratings	Unit
V_{DSS}	Drain - Source Breakdown Voltage	1200	V
I_D	Continuous Drain Current	$T_c = 25^\circ C$	215
		$T_c = 80^\circ C$	160
I_{DM}	Pulsed Drain current	440	
V_{GS}	Gate - Source Voltage	-10/+25	V
$R_{DS(on)}$	Drain - Source ON Resistance	13	m Ω
P_D	Maximum Power Dissipation	$T_c = 25^\circ C$ 1000	W

CAUTION: These Devices are sensitive to Electrostatic Discharge. Proper Handling Procedures Should Be Followed.
See application note APT0502 on www.microsemi.com

Q1 to Q4 Electrical Characteristics (per SiC MOSFET)

<i>Symbol</i>	<i>Characteristic</i>	<i>Test Conditions</i>	<i>Min</i>	<i>Typ</i>	<i>Max</i>	<i>Unit</i>
I_{DSS}	Zero Gate Voltage Drain Current	$V_{GS} = 0V$; $V_{DS} = 1200V$		100	800	μA
$R_{DS(on)}$	Drain – Source on Resistance	$V_{GS} = 20V$ $I_D = 160A$	$T_j = 25^\circ C$	19	13	m Ω
			$T_j = 150^\circ C$	75	26	
$V_{GS(th)}$	Gate Threshold Voltage	$V_{GS} = V_{DS}$; $I_D = 8mA$	1.7	2.2		V
I_{GSS}	Gate – Source Leakage Current	$V_{GS} = 20V$, $V_{DS} = 0V$			2	μA

Q1 to Q4 Dynamic Characteristics (per SiC MOSFET)

<i>Symbol</i>	<i>Characteristic</i>	<i>Test Conditions</i>	<i>Min</i>	<i>Typ</i>	<i>Max</i>	<i>Unit</i>
C_{iss}	Input Capacitance	$V_{GS} = 0V$		7600		pF
C_{oss}	Output Capacitance	$V_{DS} = 1000V$		640		
C_{riss}	Reverse Transfer Capacitance	$f = 1MHz$		52		
Q_g	Total gate Charge	$V_{GS} = 20V$		392		nC
Q_{gs}	Gate – Source Charge	$V_{Bus} = 800V$		88		
Q_{gd}	Gate – Drain Charge	$I_D = 160A$		144		
$T_{d(on)}$	Turn-on Delay Time	$V_{GS} = -5/+20V$		12		ns
T_r	Rise Time	$V_{Bus} = 800V$		14		
$T_{d(off)}$	Turn-off Delay Time	$I_D = 160A$		23		
T_f	Fall Time	$R_L = 5\Omega$; $R_G = 6.25\Omega$		18		
E_{on}	Turn on Energy	Inductive Switching $V_{GS} = -5/+20V$ $V_{Bus} = 600V$	$T_j = 150^\circ C$	3.5		mJ
E_{off}	Turn off Energy	$I_D = 160A$ $R_G = 6.25\Omega$	$T_j = 150^\circ C$	2		mJ
R_{thJC}	Junction to Case Thermal Resistance				0.13	$^\circ C/W$

Source - Drain diode ratings and characteristics (per SiC MOSFET)

<i>Symbol</i>	<i>Characteristic</i>	<i>Test Conditions</i>	<i>Min</i>	<i>Typ</i>	<i>Max</i>	<i>Unit</i>
V_{SD}	Diode Forward Voltage	$V_{GS} = -5V$; $I_F = 80A$		3.3		V
		$V_{GS} = -2V$; $I_F = 80A$		3.1		
t_{rr}	Reverse Recovery Time	$I_F = 160A$; $V_R = 800V$		40		ns
Q_{rr}	Reverse Recovery Charge	$di_s/dt = 2800A/\mu s$; $V_{GS} = -5V$		1.3		μC

CR5 & CR6 SiC diode ratings and characteristics (Per SiC diode)

<i>Symbol</i>	<i>Characteristic</i>	<i>Test Conditions</i>		<i>Min</i>	<i>Typ</i>	<i>Max</i>	<i>Unit</i>
V _{RRM}	Maximum Peak Repetitive Reverse Voltage			600			V
I _{RM}	Maximum Reverse Leakage Current	V _R =600V	T _j = 25°C		220	1320	μA
			T _j = 175°C		440	6600	
I _F	DC Forward Current		T _c = 125°C		220		A
V _F	Diode Forward Voltage	I _F = 220A	T _j = 25°C		1.6	1.8	V
			T _j = 175°C		2	2.4	
Q _C	Total Capacitive Charge	I _F = 220A, V _R = 600V di/dt = 5000A/μs			616		nC
C	Total Capacitance	f = 1MHz, V _R = 200V			1430		pF
		f = 1MHz, V _R = 400V			1100		
R _{thJC}	Junction to Case Thermal Resistance					0.1	°C/W

CR7 & CR8 diode ratings and characteristics (Per SiC diode)

<i>Symbol</i>	<i>Characteristic</i>	<i>Test Conditions</i>		<i>Min</i>	<i>Typ</i>	<i>Max</i>	<i>Unit</i>
V _{RRM}	Maximum Peak Repetitive Reverse Voltage			1200			V
I _{RM}	Maximum Reverse Leakage Current	V _R =1200V	T _j = 25°C		280	1600	μA
			T _j = 175°C		520	3200	
I _F	DC Forward Current		T _c = 125°C		160		A
V _F	Diode Forward Voltage	I _F = 160A	T _j = 25°C		1.5	1.8	V
			T _j = 175°C		2.2	3	
Q _C	Total Capacitive Charge	I _F = 160A, V _R = 1200V di/dt = 1600A/μs			1040		nC
C	Total Capacitance	f = 1MHz, V _R = 400V			744		pF
		f = 1MHz, V _R = 800V			536		
R _{thJC}	Junction to Case Thermal Resistance					0.18	°C/W

Thermal and package characteristics

<i>Symbol</i>	<i>Characteristic</i>			<i>Min</i>	<i>Typ</i>	<i>Max</i>	<i>Unit</i>
V _{ISOL}	RMS Isolation Voltage, any terminal to case t=1 min, 50/60Hz			4000			V
T _J	Operating junction temperature range	SiC MOSFET		-40		150	°C
		SiC diode		-40		175	
T _{JOP}	Recommended junction temperature under switching conditions			-40		T _{jmax} -25	
T _{STG}	Storage Temperature Range			-40		125	
T _C	Operating Case Temperature			-40		125	
Torque	Mounting torque	To heatsink	M6	3		5	N.m
		For terminals	M5	2		3.5	
Wt	Package Weight					300	g

SP6 Package outline (dimensions in mm)

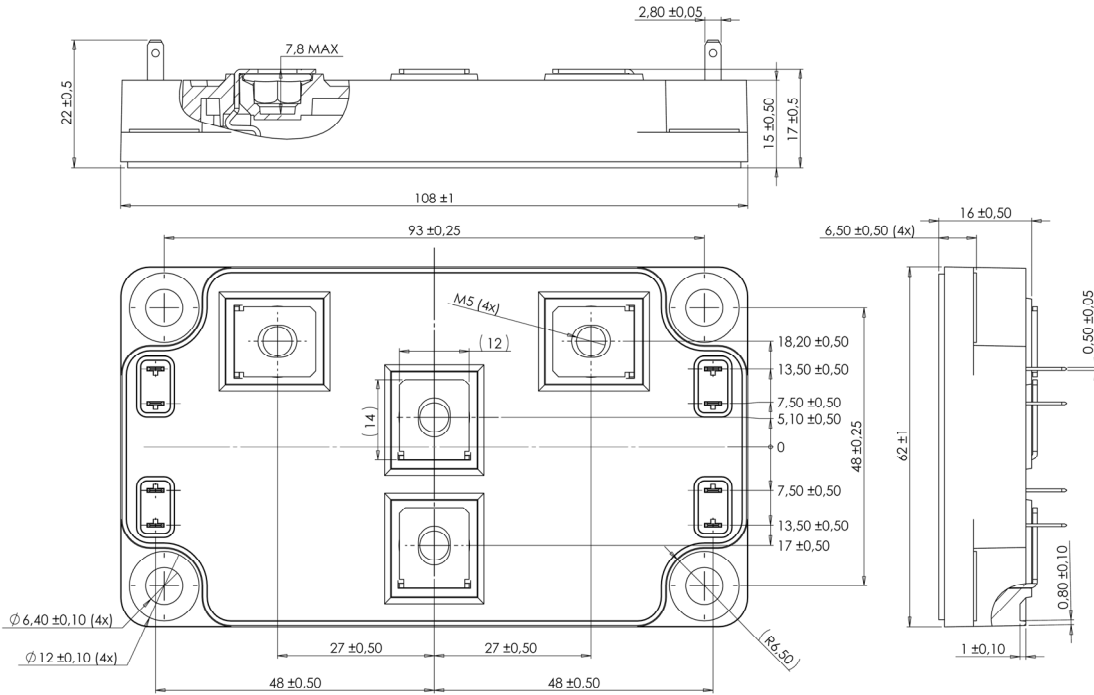

See application note APT0601 - Mounting Instructions for SP6 Power Modules on www.microsemi.com

Q1 to Q4 Typical performance curve

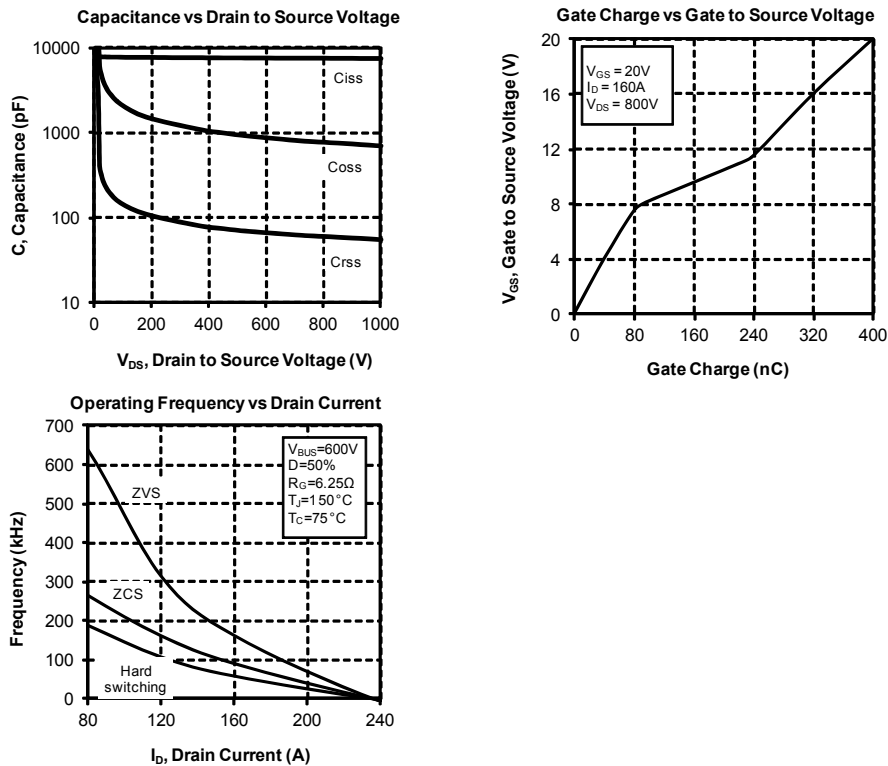

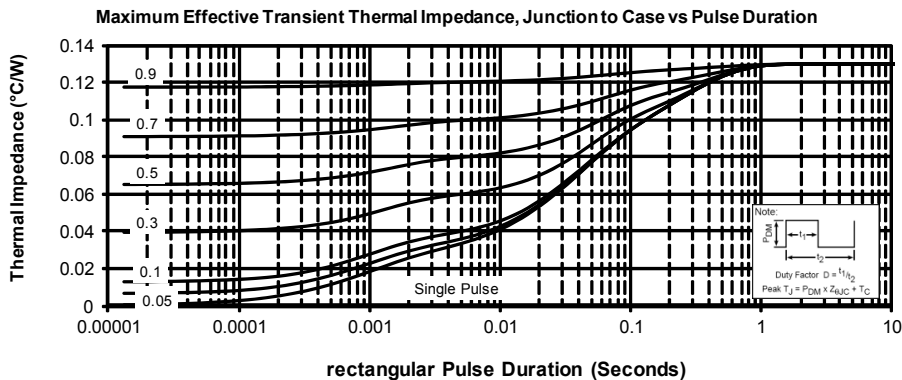
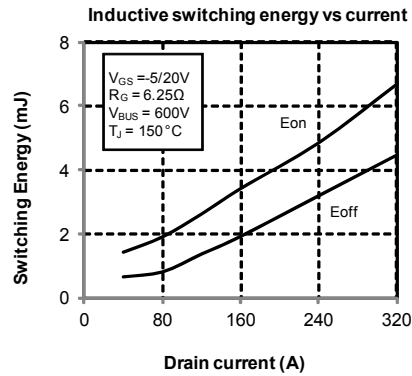
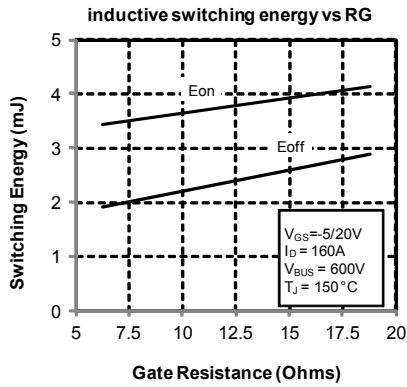
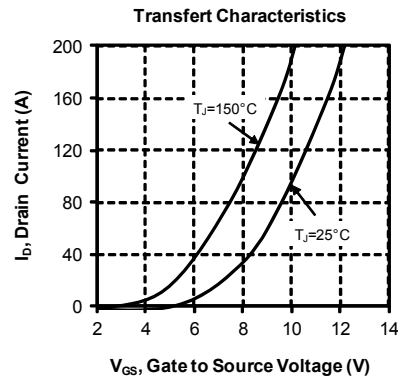
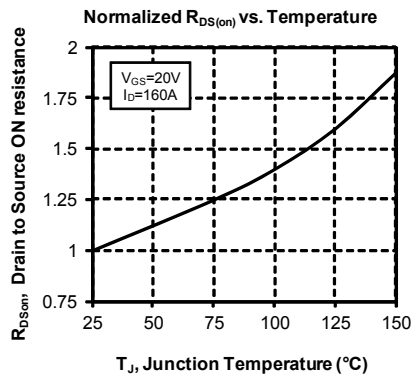
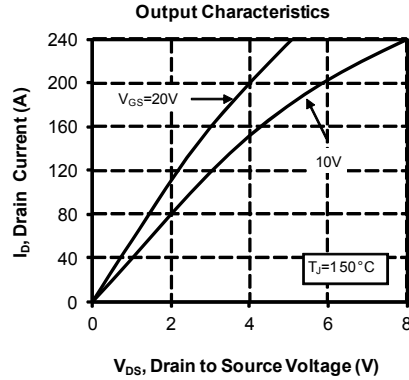
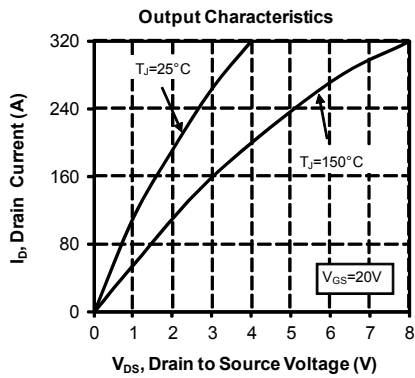

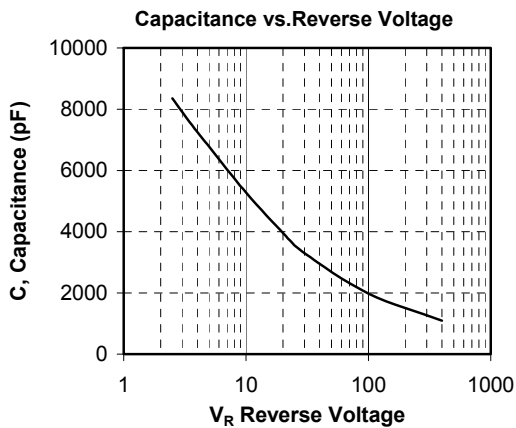
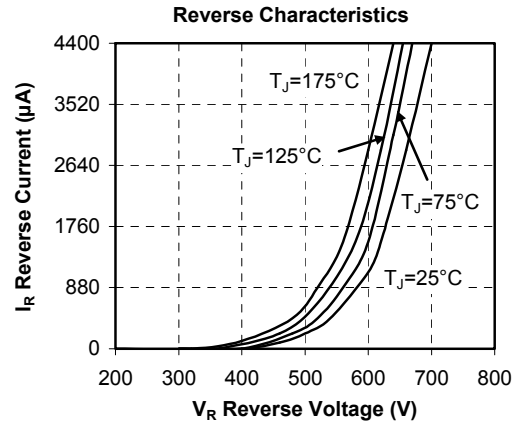
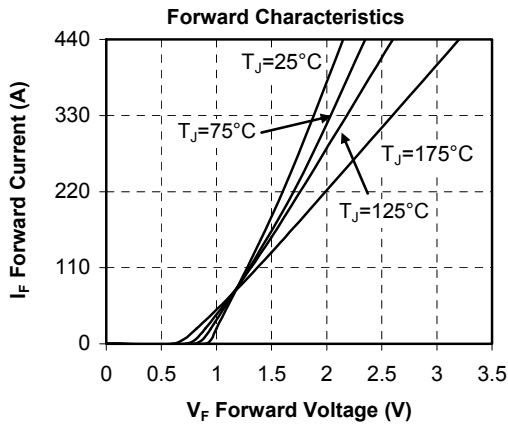
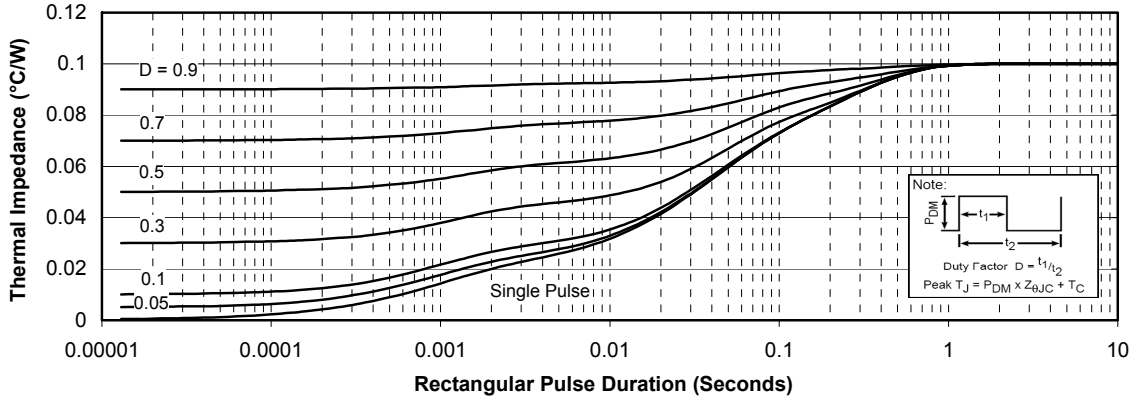
CR5 & CR6 Typical performance curve
Maximum Effective Transient Thermal Impedance, Junction to Case vs Pulse Duration

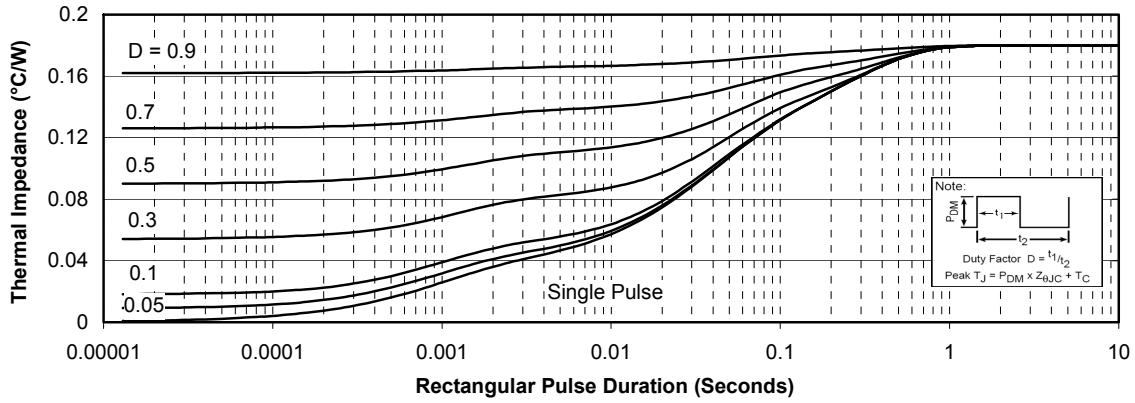
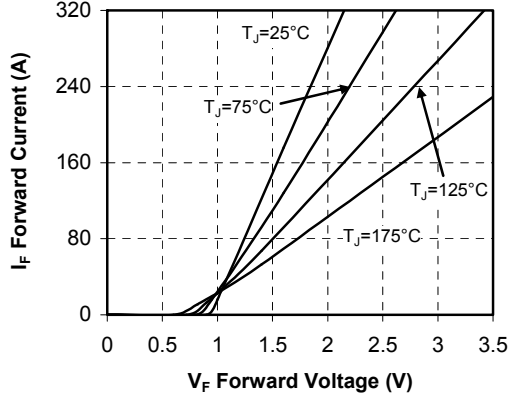
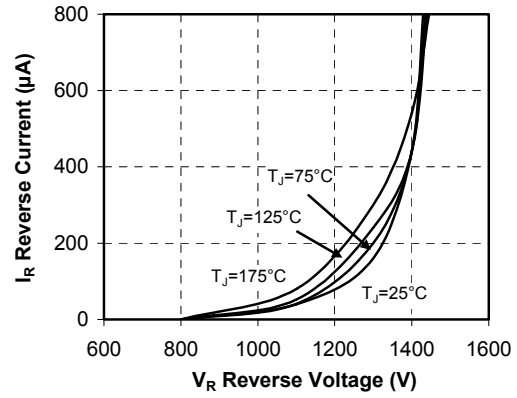
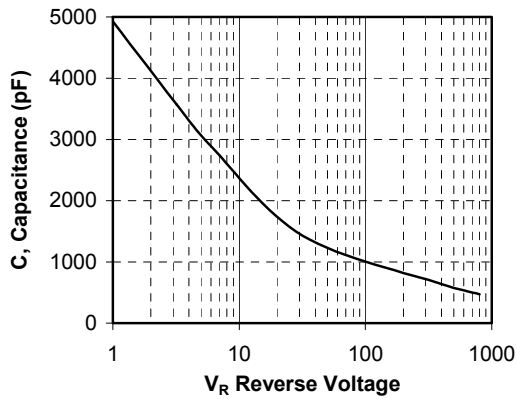
CR7 & CR8 Typical performance curve
Maximum Effective Transient Thermal Impedance, Junction to Case vs Pulse Duration

Forward Characteristics

Reverse Characteristics

Capacitance vs. Reverse Voltage

DISCLAIMER

The information contained in the document (unless it is publicly available on the Web without access restrictions) is PROPRIETARY AND CONFIDENTIAL information of Microsemi and cannot be copied, published, uploaded, posted, transmitted, distributed or disclosed or used without the express duly signed written consent of Microsemi. If the recipient of this document has entered into a disclosure agreement with Microsemi, then the terms of such Agreement will also apply. This document and the information contained herein may not be modified, by any person other than authorized personnel of Microsemi. No license under any patent, copyright, trade secret or other intellectual property right is granted to or conferred upon you by disclosure or delivery of the information, either expressly, by implication, inducement, estoppels or otherwise. Any license under such intellectual property rights must be approved by Microsemi in writing signed by an officer of Microsemi.

Microsemi reserves the right to change the configuration, functionality and performance of its products at anytime without any notice. This product has been subject to limited testing and should not be used in conjunction with life-support or other mission-critical equipment or applications. Microsemi assumes no liability whatsoever, and Microsemi disclaims any express or implied warranty, relating to sale and/or use of Microsemi products including liability or warranties relating to fitness for a particular purpose, merchantability, or infringement of any patent, copyright or other intellectual property right. Any performance specifications believed to be reliable but are not verified and customer or user must conduct and complete all performance and other testing of this product as well as any user or customers final application. User or customer shall not rely on any data and performance specifications or parameters provided by Microsemi. It is the customer's and user's responsibility to independently determine suitability of any Microsemi product and to test and verify the same. The information contained herein is provided "AS IS, WHERE IS" and with all faults, and the entire risk associated with such information is entirely with the User. Microsemi specifically disclaims any liability of any kind including for consequential, incidental and punitive damages as well as lost profit. The product is subject to other terms and conditions which can be located on the web at <http://www.microsemi.com/legal/tnc.asp>

Life Support Application

Seller's Products are not designed, intended, or authorized for use as components in systems intended for space, aviation, surgical implant into the body, in other applications intended to support or sustain life, or for any other application in which the failure of the Seller's Product could create a situation where personal injury, death or property damage or loss may occur (collectively "Life Support Applications").

Buyer agrees not to use Products in any Life Support Applications and to the extent it does it shall conduct extensive testing of the Product in such applications and further agrees to indemnify and hold Seller, and its officers, employees, subsidiaries, affiliates, agents, sales representatives and distributors harmless against all claims, costs, damages and expenses, and attorneys' fees and costs arising, directly or indirectly, out of any claims of personal injury, death, damage or otherwise associated with the use of the goods in Life Support Applications, even if such claim includes allegations that Seller was negligent regarding the design or manufacture of the goods.

Buyer must notify Seller in writing before using Seller's Products in Life Support Applications. Seller will study with Buyer alternative solutions to meet Buyer application specification based on Sellers sales conditions applicable for the new proposed specific part.