

## N-CHANNEL J-FET DEPLETION MODE

Equivalent to MIL-PRF-19500/375

### DEVICES

<b>2N3821</b>	<b>2N3821UB</b>
<b>2N3822</b>	<b>2N3822UB</b>
<b>2N3823</b>	<b>2N3823UB</b>

### LEVELS

**MQ = JAN Equivalent**  
**MX = JANTX Equivalent**  
**MV = JANTXV Equivalent**

### ABSOLUTE MAXIMUM RATINGS ( $T_C = +25^\circ\text{C}$ unless otherwise noted)

Parameters / Test Conditions	Symbol	2N3821, UB 2N3822, UB	2N3823, UB	Unit
Gate-Source Voltage	$V_{GSR}$	50	30	V
Drain-Source Voltage	$V_{DS}$	50	30	V
Drain-Gate Voltage	$V_{DG}$	50	30	V
Gate Current	$I_{GF}$	10		mA
Power Dissipation $T_A = +25^\circ\text{C}^{(1)}$	$P_T$	300		mW
Operating Junction & Storage Temperature Range	$T_j, T_{stg}$	-55 to +200		$^\circ\text{C}$

**Note:** (1) Derate linearly 1.7mW/ $^\circ\text{C}$  for  $T_A > +25^\circ\text{C}$ .

### ELECTRICAL CHARACTERISTICS ( $T_A = +25^\circ\text{C}$ , unless otherwise noted)

Parameters / Test Conditions	Symbol	Min.	Max.	Unit
<b>OFF CHARACTERISTICS</b>				
Gate-Source Breakdown Voltage $V_{DS} = 0, I_G = 1.0\mu\text{A dc}$	2N3821 / UB 2N3822 / UB 2N3823 / UB	$V_{(BR)GSSR}$	50 50 30	Vdc
Gate Reverse Current $V_{DS} = 0, V_{GS} = 30\text{V dc}$ $V_{DS} = 0, V_{GS} = 30\text{V dc}$ $V_{DS} = 0, V_{GS} = 20\text{V dc}$	2N3821 / UB 2N3822 / UB 2N3823 / UB	$I_{GSSR}$	0.1 0.1 0.5	$\eta\text{A}$
Zero-Gate-Voltage Drain Current $V_{GS} = 0, V_{DS} = 15\text{V dc}$	2N3821 / UB 2N3822 / UB 2N3823 / UB	$I_{DSS}$	0.5 2.0 4.0	2.5 10 20 mA
Gate-Source Voltage $V_{DS} = 15\text{V dc}, I_D = 50\mu\text{A dc}$ $V_{DS} = 15\text{V dc}, I_D = 200\mu\text{A dc}$ $V_{DS} = 15\text{V dc}, I_D = 400\mu\text{A dc}$	2N3821 / UB 2N3822 / UB 2N3823 / UB	$V_{GS}$	0.5 1.0 1.0	2.0 4.0 7.5 Vdc
Gate-Source Cutoff Voltage $V_{DS} = 15\text{V dc}, I_D = 0.5\eta\text{A dc}$	2N3821 / UB 2N3822 / UB 2N3823 / UB	$V_{GS(off)}$	4.0 6.0 8.0	Vdc

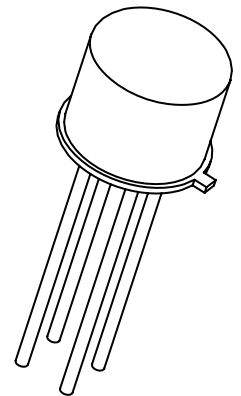

**TO-72 (TO-206AF)**

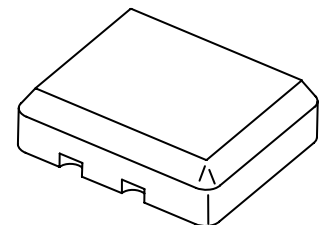

**UB - Package**

## DYNAMIC CHARACTERISTICS

Parameters / Test Conditions	Symbol	Min.	Max.	Unit
Small-Signal Common Source, Short-Circuit Forward Transfer Admittance $V_{GS} = 0$ , $V_{DS} = 15V$ dc, $f = 1.0kHz$ 2N3821 / UB 2N3822 / UB 2N3823 / UB	$ y_{fs} ^1$	1500 3000 3500	4500 6500 6500	$\mu S$
Small-Signal, Common Source, Short-Circuit Output Admittance $V_{GS} = 0$ , $V_{DS} = 15V$ dc, $f = 1.0kHz$ 2N3821 / UB 2N3822 / UB 2N3823 / UB	$ y_{os} $		10 20 35	$\mu S$
Small-Signal, Common-Source Short-Circuit Input Capacitance $V_{GS} = 0V$ dc, $V_{DS} = 15V$ dc, $100kHz \leq f \leq 1.0MHz$	$C_{iss}$		6.0	pF
Small-Signal, Common-Source Reverse Transfer Capacitance $V_{DS} = 15V$ dc, $V_{GS} = 0$ , $100kHz \leq f \leq 1.0MHz$ 2N3821 / UB 2N3822 / UB 2N3823 / UB	$C_{rss}$		3.0 3.0 2.0	pF
Small-Signal, Common-Source, Short-Circuit Forward Transfer Admittance $V_{GS} = 0$ , $V_{DS} = 15V$ dc, $f = 100MHz$ $f = 100MHz$ $f = 200MHz$ 2N3821 / UB 2N3822 / UB 2N3823 / UB	$ y_{fs} ^3$	1500 3000 3200		$\mu S$
Small-Signal, Common-Source Short-Circuit Input Conductance $V_{GS} = 0$ , $V_{DS} = 15V$ dc, $f = 200MHz$ 2N3823 (only)	$g_{is}$		800	$\mu S$
Small-Signal, Common-Source Short-Circuit Output Conductance $V_{GS} = 0$ , $V_{DS} = 15V$ dc, $f = 200MHz$ 2N3823 (only)	$g_{os}$		200	$\mu S$
Common Source Spot Noise Figure $V_{GS} = 0$ , $V_{DS} = 15V$ dc, $R_G = 1M\Omega$ $f = 10Hz$ $f = 1.0kHz$ 2N382, 2N3822 / UB 2N3821, 2N3822, 2N3823 / UB	NF <sup>1</sup>		5.0 2.0	dB
Common Source Spot Noise Figure $V_{GS} = 0$ , $V_{DS} = 15V$ dc, $R_G = 1k\Omega$ $f = 105MHz$ 2N3823 / UB (only)	NF <sup>2</sup>		2.5	dB

## PACKAGE DIMENSIONS

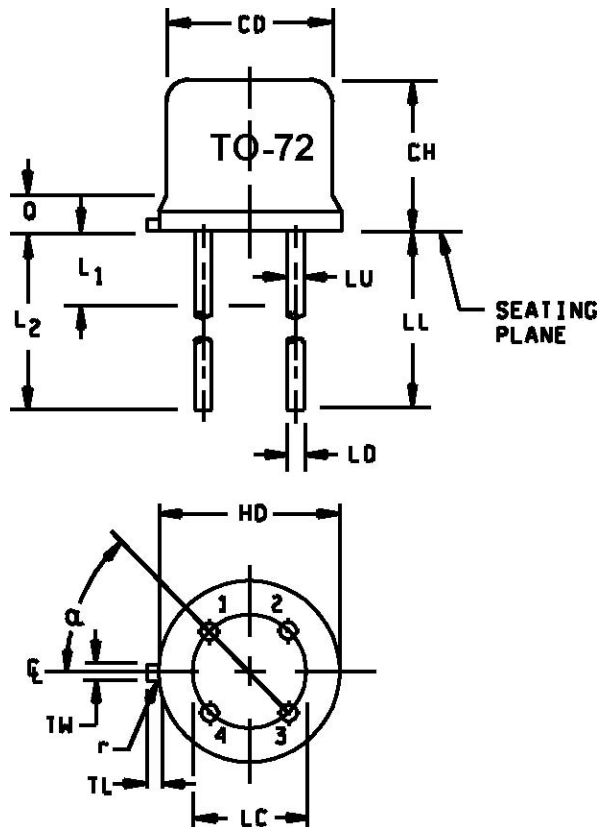

Ltr	Dimensions				Notes
	Inches		Millimeters		
	Min	Max	Min	Max	
CD	.178	.195	4.52	4.95	
CH	.170	.210	4.32	5.33	
HD	.209	.230	5.31	5.84	
L1		.050		1.27	
L2	.250		6.35		
LC	.100 TP		2.54 TP		
LD	.016	.021	0.41	0.53	2, 6
LL	.500	.750	12.70	19.05	6
LU	.016	.019	0.41	0.48	3, 6
Q		.040		1.02	
r		.007		0.18	
TL	.028	.048	0.71	1.22	8
TW	.036	.046	0.91	1.17	
$\alpha$	45° TP				

### NOTE:

- \* 1 Dimensions are in inches. Millimeters are given for general information only.
- 2 Measured in the zone beyond .250 (6.35 mm) from the seating plane.
- 3 Measured in the zone .050 (1.27 mm) and .250 (6.35 mm) from the seating plane.
- 4 When measured in a gauging plane .054 +.001, -.000 (1.37 +.3, -.00 mm) before the seating plane of the transistor, maximum diameter leads shall be within .007 (.18 mm) of their true location relative to a maximum width tab. Smaller diameter leads shall fall within the outline of the maximum diameter lead tolerance.
- 5 The active elements are electrically insulated from the case.
- 6 All 4 leads.
- 7 Lead 1 is the source, lead 2 is the drain, lead 3 is the gate, and lead 4 is the case.
- 8 Symbol TL is measured from HD maximum.
- 9 In accordance with ASME Y14.5M, diameters are equivalent to  $\phi x$  symbology.

\*FIGURE 1 Physical dimensions (similar to TO-72)

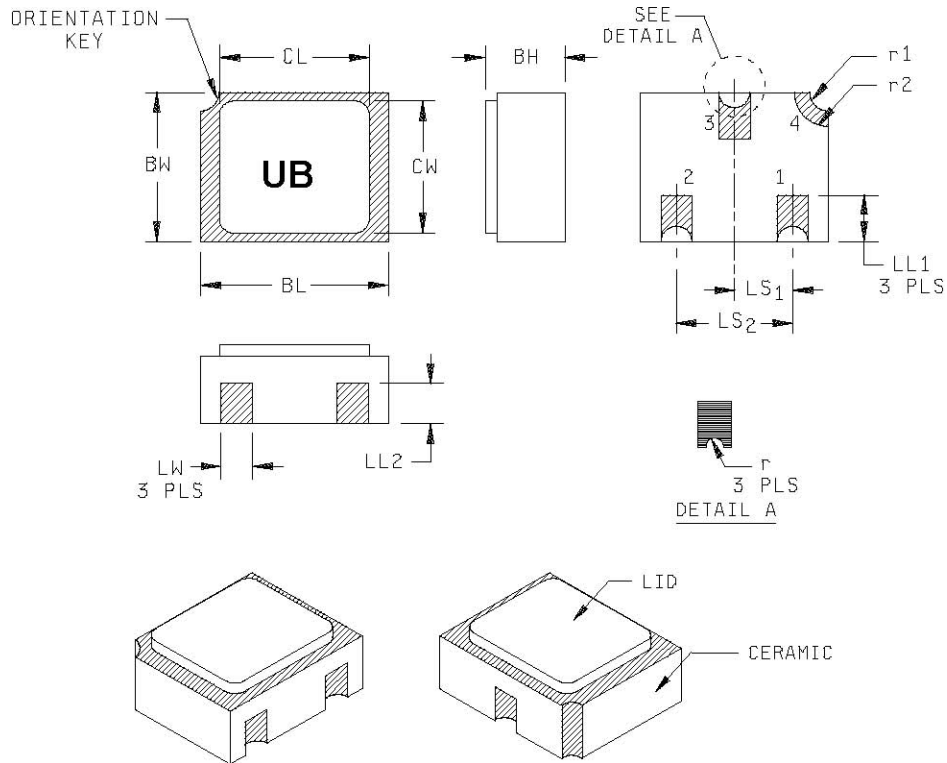

**NOTES:**

- 1. Dimensions are in inches.
- \* 2. Millimeters are given for general information only.
- \* 3. Hatched areas on package denote metallized areas.
- \* 4. Lid material: Kovar.
- \* 5. Pad 1 = Drain, Pad 2 = Source, Pad 3 = Gate, Pad 4 = Shielding connected to the lid.

Symbol	Dimensions				Note
	Inches		Millimeters		
	Min	Max	Min	Max	
BH	.046	.056	1.17	1.42	
BL	.115	.128	2.92	3.25	
BW	.085	.108	2.16	2.74	
CL		.128		3.25	
CW		.108		2.74	
LL <sub>1</sub>	.022	.038	0.56	0.96	
LL <sub>2</sub>	.017	.035	0.43	0.89	
LS <sub>1</sub>	.036	.040	0.91	1.02	
LS <sub>2</sub>	.071	.079	1.81	2.01	
LW	.016	.024	0.41	0.61	
r		.008		.203	
r1		.012		.305	
r2		.022		.559	

\* **FIGURE 2.** Physical dimensions, surface mount (2N3821UB, 2N3822UB, AND 2N3823UB).