

DESCRIPTION

The LX1670 is a complete precision reference and voltage monitor circuit for the Intel Pentium® Pro Processor and other high-end microprocessor supplies. It is designed for use in conjunction with the LX1660/1661 PWM controller. The LX1670 reads a 5-bit voltage identification (VID) code from the microprocessor and sets the output

voltage reference to be used by the LX1660/61 controller. Together, they convert +5 or 12V input power to an adjustable output ranging from 1.8VDC to 3.5VDC in 100mV steps (50mV steps below 2.1V) with 1% DC system accuracy.

IMPORTANT: For the most current data, consult MICROSEMI's website: <http://www.microsemi.com>

KEY FEATURES

- 1% TOTAL OUTPUT ERROR
- POWER GOOD, UV, 0V COMPARATORS
- 0V COMPARATOR HAS SCR DRIVE
- UNDER-VOLTAGE LOCKOUT CAPABILITY
- 5-BIT INPUT FOR ADVANCED PENTIUM PRO PROCESSOR APPLICATIONS (5TH BIT IS FOR AUTOMATIC GAIN AND OFFSET SCALING)
- IMPLEMENTS 1% DC ACCURATE CONTROL SYSTEM
- 14-PIN NARROW BODY SOIC PACKAGE

PRODUCT HIGHLIGHT

TYPICAL APPLICATION OF THE LX1670

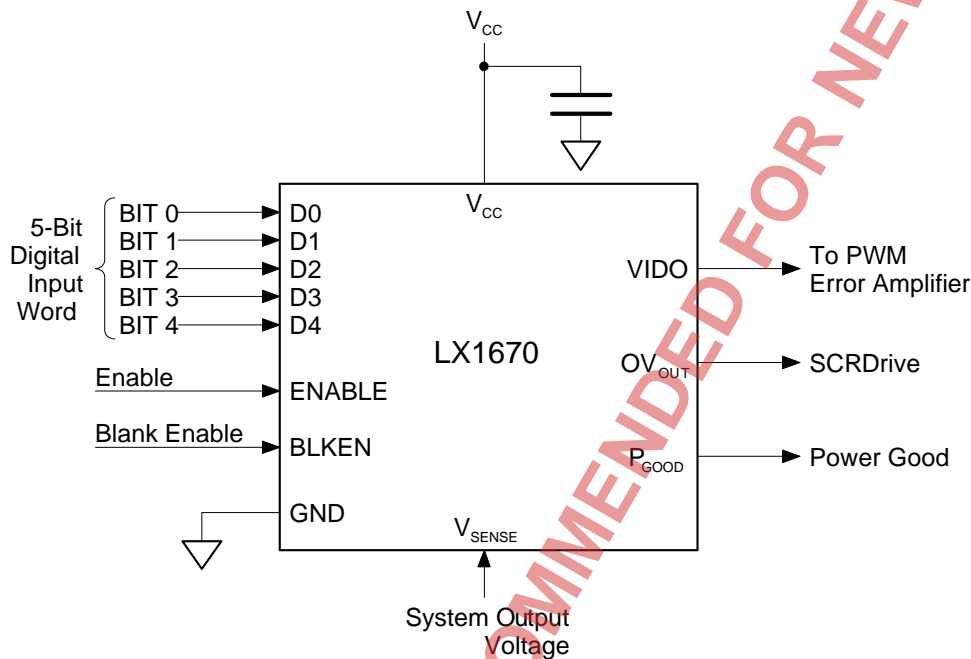

APPLICATIONS

- PENTIUM II & PENTIUM PRO VOLTAGE REGULATOR MODULES
- PROGRAMMABLE POWER SUPPLIES
- VOLTAGE REFERENCE
- ADVANCED MICROPROCESSOR SUPPLIES

PACKAGE ORDER INFO

T_A (°C)	D Plastic SOIC 14-Pin
	RoHS Compliant / Pb-free Transition DC:0440
0 to 70	LX1670CD

Note: Available in Tape & Reel. Append the letters "TR" to the part number. (i.e. LX1670CD-TR)

ABSOLUTE MAXIMUM RATINGS (Note 1)

Supply Voltage (V_{CC})	-0.3V to +15V
P_{GOOD} , D0-D3, D4, ENABLE, BLKEN	-0.3V to $V_{CC}+0.3$
VIDO, OV_{OUT} , V_{SENSE}	-0.3V to +5V
OV_{OUT}	-35mA
VIDO	-5mA
Operating Junction Temperature	
Plastic (D Package)	150°C
Storage Temperature Range	-65°C to +150°C
Peak Package Solder Reflow Temp. (40 seconds maximum exposure).....	260°C (+0, -5)

Note 1. Exceeding these ratings could cause damage to the device. All voltages are with respect to Ground. Currents are positive into, negative out of the specified terminal. Pin numbers refer to DIL packages only.

THERMAL DATA

D PACKAGE:

THERMAL RESISTANCE-JUNCTION TO AMBIENT, θ_{JA}	120°C/W
---	----------------

Junction Temperature Calculation: $T_J = T_A + (P_D \times \theta_{JA})$.

The θ_{JA} numbers are guidelines for the thermal performance of the device/pc-board system. All of the above assume no ambient airflow

PACKAGE PIN OUTS

VIDO	□	1	14	□	V_{CC}
V_{SENSE}	□	2	13	□	D4B
P_{GOOD}	□	3	12	□	D4
OV_{OUT}	□	4	11	□	D3
ENABLE	□	5	10	□	D2
BLKEN	□	6	9	□	D1
GND	□	7	8	□	D0

D PACKAGE (Top View)

RoHS / Pb-free 100% Matte Tin Lead Finish

NOT RECOMMENDED FOR NEW DESIGNS

5-BIT PROGRAMMABLE VOLTAGE REFERENCE

PRODUCTION DATA SHEET

ELECTRICAL CHARACTERISTICS

(Unless otherwise specified, these specifications apply over the operating ambient temperatures for LX1670C with $0^{\circ}\text{C} \leq T_A \leq 70^{\circ}\text{C}$; $10.8\text{V} < V_{CC} < 13.2\text{V}$, D0-D3 = Open, D4 = Open, ENABLE = 1, BLKEN = 1. Nominal conditions: $V_{CC} = 12.0\text{V}$, $T = 25^{\circ}\text{C}$. Currents flowing into chip are positive. Current maximums are currents with the highest possible value.)

Parameter	Symbol	Test Conditions	LX1670			Units
			Min.	Typ.	Max.	
Power Supply Current and Power Section						
Positive 12V Supply Current	I_{CC}	All outputs, inputs unloaded		5		mA
Digital-to-Analog Converter Section (Includes DAC, I-V Converter and output scaling amplifier. $R_{LOAD} > 1\text{k}$, $C_{LOAD} < 100\text{pF}$)						
Voltage Set Point Accuracy	VSPA	D0-D3 = X, D4 = Open, $2.00 \leq \text{VIDO} \leq 3.50\text{V}$	-1.0		1.0	%
		D0-D3 = X, D4 = GND, $1.80 \leq \text{VIDO} \leq 2.05\text{V}$	-1.5		1.5	%
LSB	VSTP	D4 = Open		100		mV
		D4 = GND		50		mV
Coding		Binary, D0 = LSB, D3 = MSB				
Under-Voltage Lockout Section						
Power-up Reset	V_{RES}	$I_{GOOD} = 5\text{mA}$			1.0	V
Threshold	UVLOT	$V_{CC} = 5\text{V}$, Supply ramping down	4.27	4.37	4.47	V
Hysteresis	UVLOH	$V_{CC} = 5\text{V}$, Supply ramping up		50		mV
Under/Over-Voltage Comparator Section						
Percent of VIDO Threshold	UOVTH		± 5.5	± 7	± 8.5	%
P_{GOOD} Low Voltage	VLG	$I_{GOOD} = 5\text{mA}$		0.2	0.4	V
Over-Voltage Protection Comparator Section						
Percent of VIDO Threshold	OVPHT		10	15	20	%
OVP Sourcing Current	IOVP	OVP = 3.0V	-20			mA
OVP Output Low	VLOVP	IOVP = 100 μA			100	mV
TTL Inputs Section						
Input Low Voltage	V_{IL}				0.8	V
Input High Voltage	V_{IH}		2.0			V
Input Low Current	I_{IL}	$V_{IL} = 0.8\text{V}$		-10		μA
Input High Current	I_{IH}	$V_{IH} = 2.0\text{V}$		0		μA
Open Drain Inputs Section (D0-D3, D4)						
Input Low Current	I_{IL}	Pin Ground		-37.5		μA
Input High Voltage	V_{IH}	Pin Open		2.0		V

NOT RECOMMENDED FOR NEW DESIGNS

FUNCTION TABLES

Table 1 - Input vs. Output Functions

V _{CC}	D4-D0	ENABLE	BLKEN	V _{SENSE} (V _S)	V _{IDO} (V _O)	P _{GOOD}	OV _{OUT}
V _{CC} < 1.0	X	X	X	X	Undefined	Undefined	Undefined
1.0 < V _{CC} < UVLOT	X	X	X	X	LOW	LOW	LOW
V _{CC} > UVLOT	X	0	X	X	LOW	LOW	LOW
V _{CC} > UVLOT	V _{IDO} Table	1	0	V _S < 0.93V _O	V _{IDO} Table 3	LOW	LOW
V _{CC} > UVLOT	V _{IDO} Table	1	0	0.93V _O < V _S < 1.07V _O	V _{IDO} Table 3	HIGH	LOW
V _{CC} > UVLOT	V _{IDO} Table	1	0	1.07V _O < V _S < 1.15V _O	V _{IDO} Table 3	LOW	LOW
V _{CC} > UVLOT	V _{IDO} Table	1	0	V _S > 1.15V _O	V _{IDO} Table 3	LOW	HIGH
V _{CC} > UVLOT	V _{IDO} Table	1	1	V _S < 0.93V _O	V _{IDO} Table 2	LOW	LOW
V _{CC} > UVLOT	V _{IDO} Table	1	1	0.93V _O < V _S < 1.07V _O	V _{IDO} Table 2	HIGH	LOW
V _{CC} > UVLOT	V _{IDO} Table	1	1	1.07V _O < V _S < 1.15V _O	V _{IDO} Table 2	LOW	LOW
V _{CC} > UVLOT	V _{IDO} Table	1	1	V _S > 1.15V _O	V _{IDO} Table 2	LOW	HIGH

Table 2 - V_{IDO} Output (BLKEN pulled high or left open)

D4	D3	D2	D1	D0	V _{IDO}	D4	D3	D2	D1	D0	V _{IDO}
0	1	1	1	1	0	1	1	1	1	1	2.00
0	1	1	1	0	0	1	1	1	1	0	2.10
0	1	1	0	1	0	1	1	1	0	1	2.20
0	1	1	0	0	0	1	1	1	0	0	2.30
0	1	0	1	1	0	1	1	0	1	1	2.40
0	1	0	1	0	0	1	1	0	1	0	2.50
0	1	0	0	1	0	1	1	0	0	1	2.60
0	1	0	0	0	0	1	1	0	0	0	2.70
0	0	1	1	1	0	1	0	1	1	1	2.80
0	0	1	1	0	0	1	0	1	1	0	2.90
0	0	1	0	1	1.800	1	0	1	0	1	3.00
0	0	1	0	0	1.850	1	0	1	0	0	3.10
0	0	0	1	1	1.900	1	0	0	1	1	3.20
0	0	0	1	0	1.950	1	0	0	1	0	3.30
0	0	0	0	1	2.000	1	0	0	0	1	3.40
0	0	0	0	0	2.050	1	0	0	0	0	3.50

Table 3 - V_{IDO} Output (BLKEN pulled low)

D4	D3	D2	D1	D0	V _{IDO}	D4	D3	D2	D1	D0	V _{IDO}
0	1	1	1	1	1.300	1	1	1	1	1	2.00
0	1	1	1	0	1.350	1	1	1	1	0	2.10
0	1	1	0	1	1.400	1	1	1	0	1	2.20
0	1	1	0	0	1.450	1	1	1	0	0	2.30
0	1	0	1	1	1.500	1	1	0	1	1	2.40
0	1	0	1	0	1.550	1	1	0	1	0	2.50
0	1	0	0	1	1.600	1	1	0	0	1	2.60
0	1	0	0	0	1.650	1	1	0	0	0	2.70
0	0	1	1	1	1.700	1	0	1	1	1	2.80
0	0	1	1	0	1.750	1	0	1	1	0	2.90
0	0	1	0	1	1.800	1	0	1	0	1	3.00
0	0	1	0	0	1.850	1	0	1	0	0	3.10
0	0	0	1	1	1.900	1	0	0	1	1	3.20
0	0	0	1	0	1.950	1	0	0	1	0	3.30
0	0	0	0	1	2.000	1	0	0	0	1	3.40
0	0	0	0	0	2.050	1	0	0	0	0	3.50

Table 4 - Mode Control

D4	ENABLE	BLKEN	Mode	State
X	0	X	Disable	V _{IDO} is pulled low through 10k
0	1	0	Low	V _{IDO} is scaled. Output 1.3V to 2.05V
1	1	0	Normal	Normal Output 2.0 to 3.5V
0	1	1	Low	V _{IDO} is scaled. Output 1.8V to 2.05V
1	1	1	Normal	Normal output 2.0 to 3.5V

5-BIT PROGRAMMABLE VOLTAGE REFERENCE

PRODUCTION DATA SHEET

BLOCK DIAGRAM

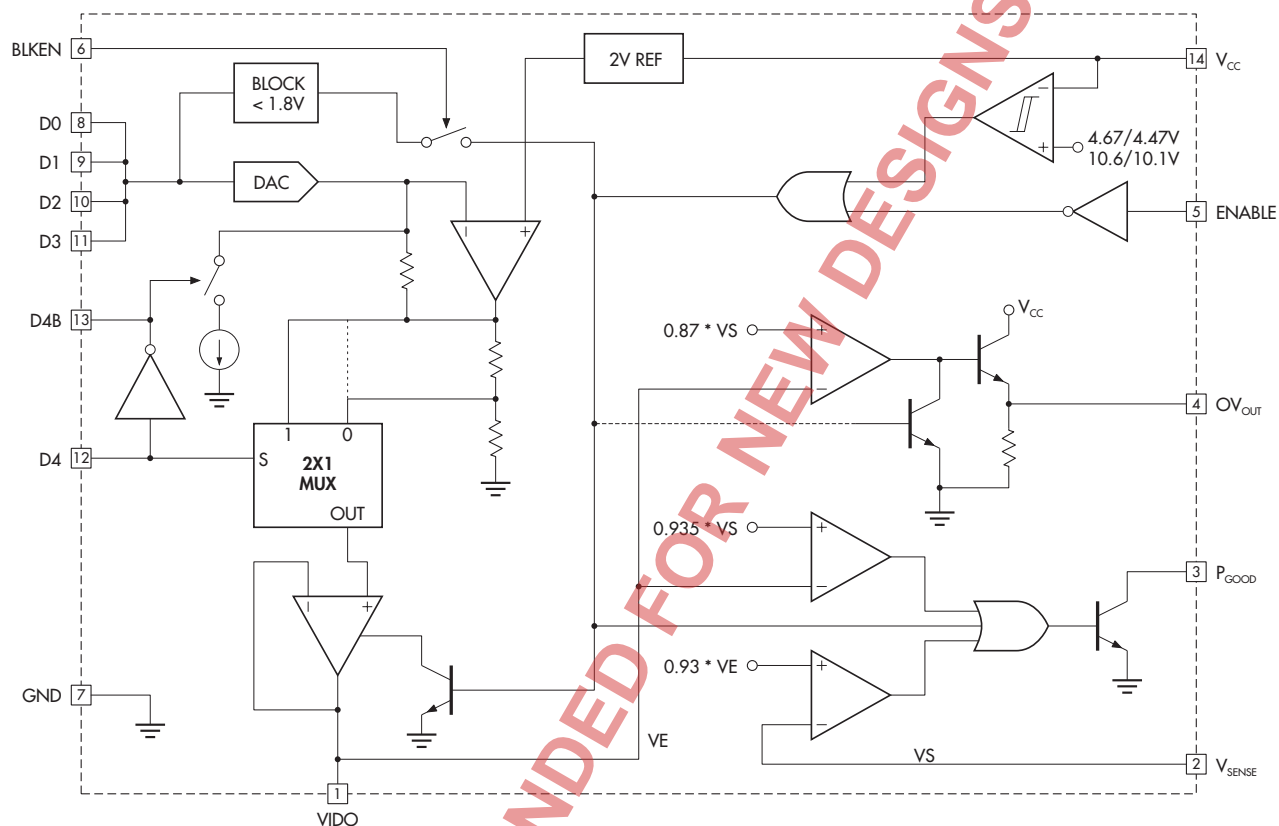

FUNCTIONAL PIN DESCRIPTION

Pin Name	Pin #	Description
VIDO	1	Output reference voltage used by PWM controller to set system voltage.
V _{SENSE}	2	Connected directly to system output voltage.
P _{GOOD}	3	Open collector output pulls low when the processor's supply is not good.
OV _{OUT}	4	SCR Driver goes high when processor supply is over voltage.
ENABLE	5	TTL compatible chip enable. Internally pulled high.
BLKEN	6	Enables or disables blocking of codes with voltage blow 1.8V for CPU protection. Internally pulled high.
GND	7	Analog ground return.
D0	8	LSB DAC logic control. Internally pulled high.
D1	9	2nd LSB DAC logic control. Internally pulled high.
D2	10	3rd LSB DAC logic control. Internally pulled high.
D3	11	MSB DAC logic control. Internally pulled high.
D4	12	Scales VIDO output when low. Internally pulled high.
D4B	13	Inverting output of D4.
V _{CC}	14	Analog power supply.

THEORY OF OPERATION

UNDER-VOLTAGE LOCKOUT

This function keeps order to the IC until the power supply voltage reaches 85% of its nominal value. The output voltage is pulled low and P_{GOOD} and OV_{OUT} are pulled low. Once the power supply voltage crosses 85%, the output voltage, VIDO, is released, and P_{GOOD} continues to be pulled low. When V_{SENSE} (the microprocessor's power supply) is within $\pm 7\%$ of VIDO, P_{GOOD} is released. The comparator has hysteresis to prevent transient oscillation.

4-BIT DAC and 5th-BIT SCALER

This function generates a precise voltage from a binary, 5-bit digital word VID [0:4]. It uses a 4-bit, binary weighted current DAC, driving a precise current to voltage converter. This voltage is then op-amp buffered and sent out. The scaling is accomplished by multiplexing the buffer op-amp. The resulting transfer function is:

$$VIDO(D0,D1,D2,D3) = (2.00 + 0.1 * (1*D0 + 2*D1 + 4*D2 + 8*D3)) \quad \text{for } D4 = 1$$

$$VIDO(D0,D1,D2,D3) = (2.00 + 0.6 + 0.1 * (1*D0 + 2*D1 + 4*D2 + 8*D3)) * 0.5 \quad \text{for } D4 = 0$$

for the code VIDO < 1.8V will be blocked and VIDO = 0.

The zero-scale output voltage, full-scale output voltage and the scale factor are all trimmed on-chip using fusible links.

OVER- / UNDER-VOLTAGE COMPARATORS

This function generates an open collector Power Good signal when V_{SENSE} is within $\pm 7\%$ of VIDO.

OVER-VOLTAGE PROTECTION

This function generates an OV_{OUT} voltage signal when V_{SENSE} is 15% higher than VIDO. This voltage can be used to drive an external SCR.

CHIP ENABLE

This function disables the chip when low. VIDO, P_{GOOD} and OV_{OUT} are all pulled low. When ENABLE is high, the chip's state is then determined by the other functions.

BLANK ENABLE

This function will disable VIDO for codes with voltages below 1.80V when this pin is high. When pulled low, this function will allow VIDO to accept codes for voltages of 1.30 to 3.50V.

NOT RECOMMENDED FOR NEW DESIGNS

5-BIT PROGRAMMABLE VOLTAGE REFERENCE

PRODUCTION DATA SHEET

APPLICATION INFORMATION

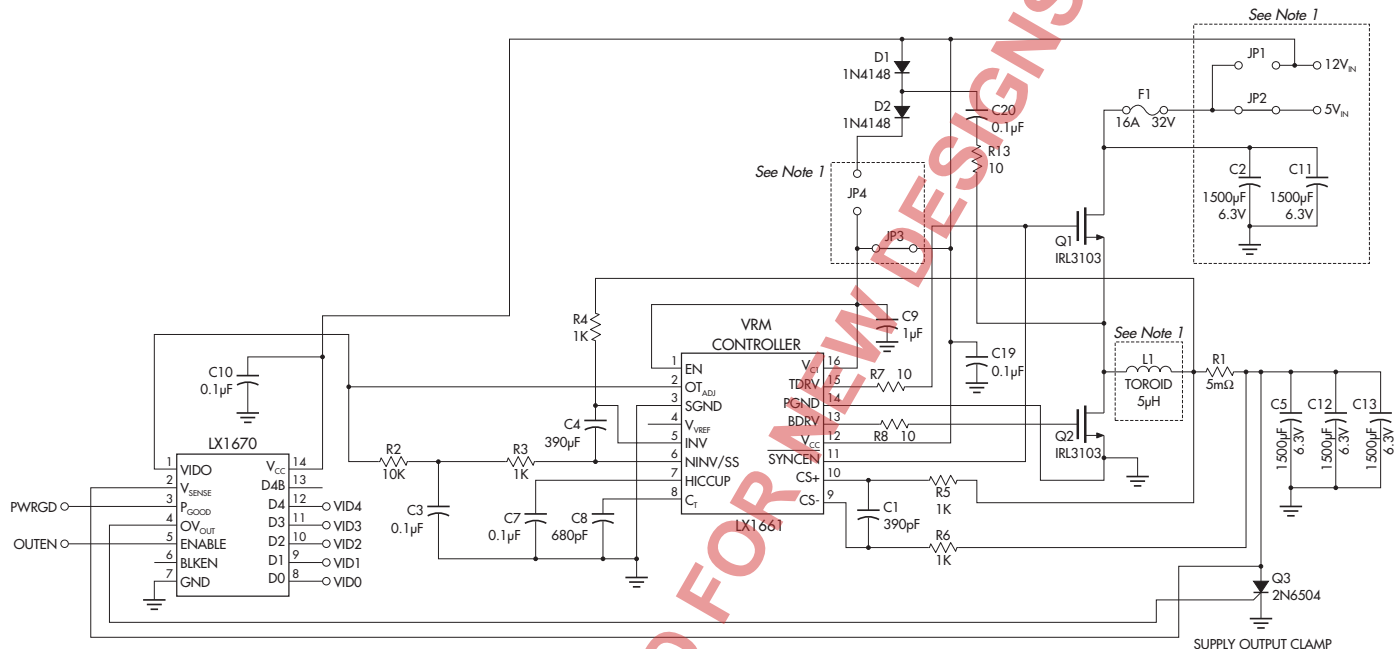

Note 1. Setup shown is for 5V application. For 12V input change the following:

- Close JP1 and JP4
- Open JP2 and JP3
- For C2 and C11, use 16V/850µF capacitors instead
- Inductor L1 = 10µH

FIGURE 1 — LX1660/61 CONTROLLER USED WITH THE LX1670 PROGRAMMABLE REFERENCE/DAC CHIP FOR PENTIUM PRO PROCESSOR OR PENTIUM II PROCESSOR APPLICATIONS. GUARANTEED TO MEET INTEL SPECIFICATIONS.

NOT RECOMMENDED FOR NEW DESIGNS

Pentium is a registered trademark of Intel Corporation.

PRODUCTION DATA - Information contained in this document is proprietary to Linfinitiy, and is current as of publication date. This document may not be modified in any way without the express written consent of Linfinitiy. Product processing does not necessarily include testing of all parameters. Linfinitiy reserves the right to change the configuration and performance of the product and to discontinue product at any time.