

PRECISION 2.5-VOLT REFERENCE

DESCRIPTION

This monolithic integrated circuit is a fully self-contained precision voltage reference generator, internally trimmed for $\pm 1\%$ accuracy. Requiring less than 2mA in quiescent current, this device can deliver in excess of 10mA with total load- and line-induced tolerances of less than 0.5%. In addition to voltage accuracy, internal trimming achieves a temperature coefficient of output voltage of typically 10 ppm/ $^{\circ}\text{C}$. As a result, these references are excellent choices for application to critical instrumentation and D-to-A converter systems.

The SG1503 is specified for operation over the full military ambient temperature range of -55°C to 125°C , while the SG2503 is designed for -25°C to 85°C and the SG3503 for commercial applications of 0°C to 70°C .

FEATURES

- Output voltage trimmed to $\pm 1\%$
- Input voltage range of 4.5 to 40V
- Temperature coefficient of 10ppm/ $^{\circ}\text{C}$
- Quiescent current typically 1.5mA
- Output current in excess of 10mA
- Interchangeable with MC1503 and AD580

HIGH RELIABILITY FEATURES - SG1503

- ◆ Available to MIL-STD-883 and DESC SMD
- ◆ Radiation data available
- ◆ LMI level "S" processing available

FUNCTIONAL DIAGRAM

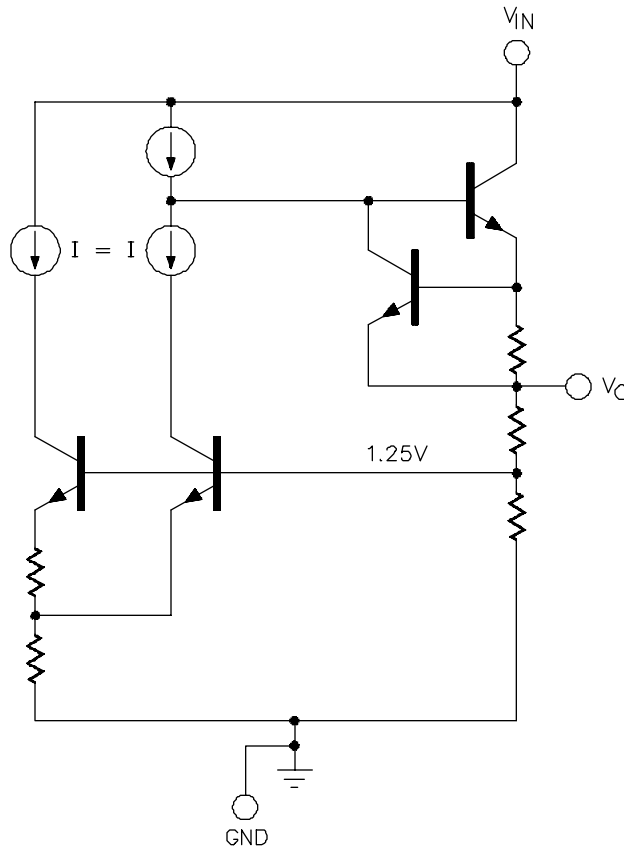

ABSOLUTE MAXIMUM RATINGS (Note 1)

Input Voltage 40V
 Storage Temperature Range -65°C to 150°C

Operating Junction Temperature
 Hermetic (T, Y - Package) 150°C
 Plastic (M, DM - Package) 150°C
 Lead Temperature (Soldering, 10 Seconds) 300°C
 Pb-free / RoHS Peak Solder Reflow Temp (40 sec. max. exp.)..... 260°C (+0, -5)

Note 1. Exceeding these ratings could cause damage to the device.

THERMAL DATA

T Package:

Thermal Resistance-Junction to Case, θ_{JC} 15°C/W
 Thermal Resistance-Junction to Ambient, θ_{JA} 120°C/W

Y Package:

Thermal Resistance-Junction to Case, θ_{JC} 50°C/W
 Thermal Resistance-Junction to Ambient, θ_{JA} 130°C/W

M Package:

Thermal Resistance-Junction to Case, θ_{JC} 60°C/W
 Thermal Resistance-Junction to Ambient, θ_{JA} 95°C/W

DM Package:

Thermal Resistance-Junction to Case, θ_{JC} 55°C/W
 Thermal Resistance-Junction to Ambient, θ_{JA} 165°C/W

Note A. Junction Temperature Calculation: $T_J = T_A + (P_D \times \theta_{JA})$.

Note B. The above numbers for θ_{JC} are maximums for the limiting thermal resistance of the package in a standard mounting configuration. The θ_{JA} numbers are meant to be guidelines for the thermal performance of the device/pc-board system. All of the above assume no ambient airflow.

RECOMMENDED OPERATING CONDITIONS (Note 2)

Input Voltage 4.5V to 40V

Operating Ambient Temperature Range
 SG1503 -55°C to 125°C
 SG2503 -25°C to 85°C
 SG3503 0°C to 70°C

Note 2. Range over which the device is functional.

ELECTRICAL CHARACTERISTICS

(Unless otherwise specified, these specifications apply over the operating ambient temperatures for SG1503 with $-55^\circ\text{C} \leq T_A \leq 125^\circ\text{C}$, SG2503/SG3503 with $0^\circ\text{C} \leq T_A \leq 70^\circ\text{C}$, $V_{IN} = 15\text{V}$, and $I_L = 0\text{mA}$. Low duty cycle pulse testing techniques are used which maintains junction and case temperatures equal to the ambient temperature.)

Parameter	Test Conditions	SG1503/2503			SG3503			Units
		Min.	Typ.	Max.	Min.	Typ.	Max.	
Output Voltage	$T_A = 25^\circ\text{C}$	2.485	2.500	2.515	2.475	2.500	2.525	V
Input Voltage		4.7		40	4.7		40	V
Line Regulation	$T_A = 25^\circ\text{C}$	4.5		40	4.5		40	V
	$V_{IN} = 5\text{V to }15\text{V}$		1	3		1	3	mV
Load Regulation	$V_{IN} = 15\text{V to }40\text{V}$		3	5		3	10	mV
	$\Delta I_L = 10\text{mA}$		3	5		3	10	mV
Temperature Regulation	$\Delta I_L = 10\text{mA}, V_{IN} = 30\text{V}$		4	8		4	15	mV
	(SG1503 only)		15	20				mV
Quiescent Current	(SG2503/3503 only)		2.5	5		5	10	mV
	$V_{IN} = 40\text{V}$		1.5	2.0		1.5	2.0	mA
Short Circuit Current	$T_A = 25^\circ\text{C}$	15	20	30	15	20	30	mA
Ripple Rejection	$f = 120\text{Hz}, T_A = 25^\circ\text{C}$		76			76		dB
Output Noise	$\text{BW} = 10\text{KHz}, T_A = 25^\circ\text{C}$		100			100		$\mu\text{V rms}$
Voltage Stability			250			250		$\mu\text{V/Khr}$

CHARACTERISTIC CURVES

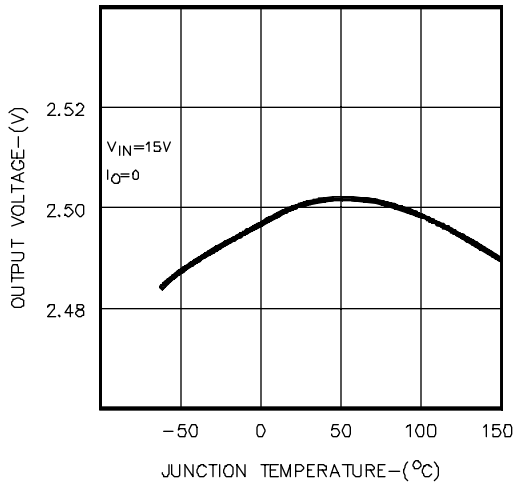

FIGURE 1.
OUTPUT VOLTAGE VS.
TEMPERATURE

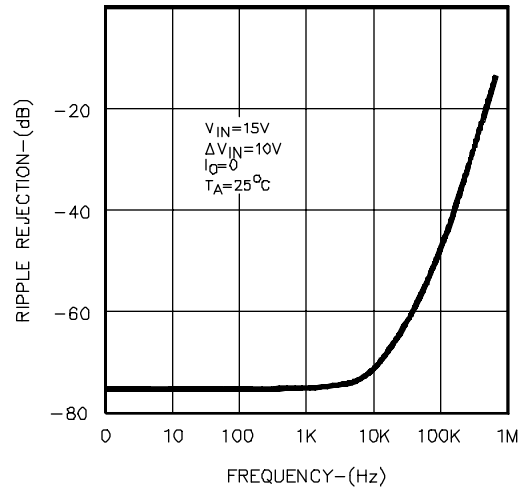

FIGURE 2.
RIPPLE REJECTION

CONNECTION DIAGRAMS & ORDERING INFORMATION (See Notes Below)

Package	Part No.	Ambient Temperature Range	Connection Diagram
8-PIN CERAMIC DIP Y - PACKAGE	SG1503Y/883B SG1503Y/DESC SG1503Y SG2503Y SG3503Y	-55°C to 125°C -55°C to 125°C -55°C to 125°C -25°C to 85°C 0°C to 70°C	<p style="text-align: center;">M Package: Pb-free / RoHS 100% Matte Tin Lead Finish</p>
8-PIN PLASTIC DIP M - PACKAGE Pb-free / RoHS Transition DC: 0503*	SG2503M SG3503M	-25°C to 85°C 0°C to 70°C	<p style="text-align: center;">Pb-free / RoHS 100% Matte Tin Lead Finish</p>
8-PIN PLASTIC SOIC DM - PACKAGE Pb-free / RoHS Transition DC: 0440*	SG3503DM SG2503DM	0°C to 70°C -25°C to 85°C	<p style="text-align: center;">Pb-free / RoHS 100% Matte Tin Lead Finish</p>
3-PIN TO-39 METAL CAN T - PACKAGE	SG1503T/883B SG1503T/DESC SG1503T SG2503T SG3503T	-55°C to 125°C -55°C to 125°C -55°C to 125°C -25°C to 85°C 0°C to 70°C	

Note 1. Contact factory for JAN and DESC product availability.
2. All packages are viewed from the top.

*RoHS compliant