

REVISIONS			
LTR	DESCRIPTION	DATE (YR-MO-DA)	APPROVED
A	Add case outline N. Make changes to 1.2.2, 1.3, and figure 1. - ro	98-12-17	R. MONNIN
B	Add case outline 2. Make changes to 1.2.2, 1.3, table I, and figure 2. - ro	99-10-21	R. MONNIN
C	Add radiation hardness requirements. Add case outline M. Make changes to 1.2.2, 1.3, table I, figure 1, and figure 2. - ro	00-02-23	R. MONNIN
D	Add case outlines 4 and 5. - ro	01-05-18	R. MONNIN
E	Make pin assignment corrections to case outlines N and 5 as specified in figure 2. - ro	02-04-15	R. MONNIN
F	Add a footnote to case outline U, TO-257 package as specified under 1.2.3 and figure 1. -rrp	05-02-04	R. MONNIN
G	For case outline T only, add footnote 1/ under 1.2.3 and make change to note 2 under figure 1. -rrp	06-01-23	R. MONNIN

THE ORIGINAL FIRST SHEET OF THIS DRAWING HAS BEEN REPLACED.

REV																							
SHEET																							
REV	G	G	G																				
SHEET	15	16	17																				
REV STATUS OF SHEETS	REV			G	G	G	G	G	G	G	G	G	G	G	G	G	G	G	G				
	SHEET			1	2	3	4	5	6	7	8	9	10	11	12	13	14						
PMIC N/A	PREPARED BY JOSEPH A. KERBY					DEFENSE SUPPLY CENTER COLUMBUS COLUMBUS, OHIO 43218-3990 http://www.dsccl.dla.mil																	
STANDARD MICROCIRCUIT DRAWING THIS DRAWING IS AVAILABLE FOR USE BY ALL DEPARTMENTS AND AGENCIES OF THE DEPARTMENT OF DEFENSE AMSC N/A	CHECKED BY CHARLES E. BESORE																						
	APPROVED BY MICHAEL A. FRYE																						
	DRAWING APPROVAL DATE 89-09-14																						
	REVISION LEVEL G																						
					SIZE A	CAGE CODE 67268	5962-88747																
					SHEET 1 OF 17																		

1. SCOPE

1.1 Scope. This drawing describes device requirements for MIL-STD-883 compliant, non-JAN class level B microcircuits in accordance with MIL-PRF-38535, appendix A.

1.2 Part or Identifying Number (PIN). The complete PIN is as shown in the following example:

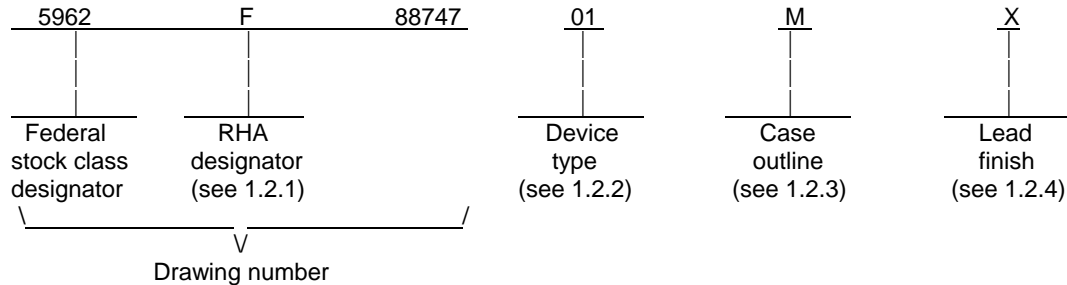

1.3 Absolute maximum ratings.

Input voltage:

Operating or input shorted to ground -35 V dc
 Transient -50 V dc 2/
 Storage temperature range -65°C to +150°C
 Lead temperature (soldering, 10 seconds) +300°C

Power dissipation (P_D):

T_C = +25°C:

Cases M, N, T, U, Z, 4, and 5 15 W
 Cases X and 2 2 W
 Case Y 20 W

T_A = +25°C:

Cases M, N, T, U, and Z 3.0 W
 Cases X and 2 1.0 W
 Case Y 3.6 W
 Case 4 1.7 W
 Case 5 1.3 W

Junction temperature (T_J) +150°C 3/

Thermal resistance, junction-to-case (θ_{JC}):

Case M 5.5°C/W
 Cases N and T 3.5°C/W
 Case U 4.2°C/W
 Case X 15°C/W
 Case Y 3°C/W
 Case Z 6°C/W
 Case 2 See MIL-STD-1835
 Case 4 5.1°C/W
 Case 5 3.6°C/W

Thermal resistance, junction-to-ambient (θ_{JA}):

Cases M, T, U, and Z 42°C/W
 Cases N, X, and 2 120°C/W
 Case Y 35°C/W
 Case 4 60°C/W
 Case 5 80°C/W

1.4 Recommended operating conditions.

Input voltage range (V_{IN}) -14.5 V dc to -27 V dc
 Ambient operating temperature range (T_A) -55°C to +125°C

1.5 Radiation features:

Maximum total dose available (dose rate = 50 – 300 rads(Si) / s) 300 Krads 4/

2/ The 50-volt input rating refers to the ability of the regulator to withstand high line or transient conditions without damage. Since the regulator's maximum current capability is reduced, the output may fall out of regulation at high input voltages under nominal loading.

3/ The device is protected by a thermal shutdown circuit which is designed to turn off the output transistor whenever the device junction temperature is in excess of +150°C.

4/ These parts may be dose rate sensitive in a space environment and may demonstrate enhanced low dose rate effects. Radiation end point limits for the noted parameters are guaranteed only for the conditions specified in MIL-STD-883, method 1019, condition A.

STANDARD MICROCIRCUIT DRAWING DEFENSE SUPPLY CENTER COLUMBUS COLUMBUS, OHIO 43218-3990	SIZE A		5962-88747
		REVISION LEVEL G	SHEET 3

2. APPLICABLE DOCUMENTS

2.1 Government specification, standards, and handbooks. The following specification, standards, and handbooks form a part of this drawing to the extent specified herein. Unless otherwise specified, the issues of these documents are those cited in the solicitation or contract.

DEPARTMENT OF DEFENSE SPECIFICATION

MIL-PRF-38535 - Integrated Circuits, Manufacturing, General Specification for.

DEPARTMENT OF DEFENSE STANDARDS

MIL-STD-883 - Test Method Standard Microcircuits.
MIL-STD-1835 - Interface Standard Electronic Component Case Outlines.

DEPARTMENT OF DEFENSE HANDBOOKS

MIL-HDBK-103 - List of Standard Microcircuit Drawings.
MIL-HDBK-780 - Standard Microcircuit Drawings.

(Copies of these documents are available online at <http://assist.daps.dla.mil/quicksearch/> or <http://assist.daps.dla.mil> or from the Standardization Document Order Desk, 700 Robbins Avenue, Building 4D, Philadelphia, PA 19111-5094.)

2.2 Order of precedence. In the event of a conflict between the text of this drawing and the references cited herein, the text of this drawing takes precedence. Nothing in this document, however, supersedes applicable laws and regulations unless a specific exemption has been obtained.

3. REQUIREMENTS

3.1 Item requirements. The individual item requirements shall be in accordance with MIL-PRF-38535, appendix A for non-JAN class level B devices and as specified herein. Product built to this drawing that is produced by a Qualified Manufacturer Listing (QML) certified and qualified manufacturer or a manufacturer who has been granted transitional certification to MIL-PRF-38535 may be processed as QML product in accordance with the manufacturers approved program plan and qualifying activity approval in accordance with MIL-PRF-38535. This QML flow as documented in the Quality Management (QM) plan may make modifications to the requirements herein. These modifications shall not affect form, fit, or function of the device. These modifications shall not affect the PIN as described herein. A "Q" or "QML" certification mark in accordance with MIL-PRF-38535 is required to identify when the QML flow option is used.

3.2 Design, construction, and physical dimensions. The design, construction, and physical dimensions shall be as specified in MIL-PRF-38535, appendix A and herein.

3.2.1 Case outlines. The case outlines shall be in accordance with 1.2.3 herein and figure 1.

3.2.2 Terminal connections. The terminal connections shall be specified on figure 2.

3.2.3 Radiation exposure circuit. The radiation exposure circuit shall be as specified on figure 3.

3.3 Electrical performance characteristics. Unless otherwise specified herein, the electrical performance characteristics are as specified in table I and shall apply over the full ambient operating temperature range.

STANDARD MICROCIRCUIT DRAWING DEFENSE SUPPLY CENTER COLUMBUS COLUMBUS, OHIO 43218-3990	SIZE A		5962-88747
		REVISION LEVEL G	SHEET 4

TABLE I. Electrical performance characteristics.

Test	Symbol	Conditions <u>1/ 2/ 3/</u> -55°C ≤ T _A ≤ +125°C unless otherwise specified	Group A subgroups	Device type	Limits		Unit
					Min	Max	
Output voltage	V _{OUT}	T _A = +25°C	1	01	-11.88	-12.12	V
		V _{IN} = -14.5 V to -27 V <u>4/</u>	1,2,3		-11.64	-12.36	
		M,D,P,L,R,F	1		-11.88	-12.12	
Line regulation <u>5/ 6/</u>	V _{RLINE}	V _{IN} = -14.5 V to -27 V	1	01		20	mV
			2,3			50	
			M,D,P,L,R,F		1		
		V _{IN} = -16 V to -22 V	1			10	
			2,3			30	
			M,D,P,L,R,F		1		
Load regulation <u>5/</u>	V _{RLOAD}	I _O = 5.0 mA to 1.5 A <u>7/</u>	1	01		32	mV
			2,3			60	
			M,D,P,L,R,F		1		
		I _O = 250 mA to 750 mA <u>7/</u>	1			16	
			2,3			30	
			M,D,P,L,R,F		1		
		I _O = 5 mA to 500 mA <u>8/</u>	1			30	
			2,3			60	
Standby current drain	I _{SCD}		1	01		3.5	mA
			2,3			4.0	
			M,D,P,L,R,F		1		
Standby current drain change with line	ΔI _{SCD} (line)	V _{IN} = -14.5 V to -27 V	1,2,3	01		0.8	mA
			M,D,P,L,R,F		1		

See footnotes at end of table.

STANDARD MICROCIRCUIT DRAWING DEFENSE SUPPLY CENTER COLUMBUS COLUMBUS, OHIO 43218-3990	SIZE A		5962-88747
		REVISION LEVEL G	SHEET 5

TABLE I. Electrical performance characteristics - Continued.

Test	Symbol	Conditions <u>1/ 2/ 3/</u> -55°C ≤ T _A ≤ +125°C unless otherwise specified	Group A subgroups	Device type	Limits		Unit	
					Min	Max		
Standby current drain change with load	ΔI _{SCD} (load)	I _O = 5.0 mA to 1000 mA	1,2,3	01		0.5	mA	
			M,D,P,L,R,F		1			0.5
Dropout voltage	V _{DO}	I _O = 1.0 A, <u>7/</u> ΔV _{OUT} = 100 mV	1,2,3	01		1.8	V	
			M,D,P,L,R,F		1			1.8
		I _O = 500 mA, <u>8/</u> ΔV _{OUT} = 100 mV	1,2,3			1.8		
Peak output current <u>4/</u>	I _O (PK)	T _A = +25°C <u>7/</u>	1	01	1.5	3.3	A	
			M,D,P,L,R,F		1	1.5		3.3
		T _A = +25°C <u>8/</u>	1		0.5	1.7		
Short circuit current <u>9/</u>	I _{OS}	V _{IN} = -35 V <u>7/</u>	1	01		1.2	A	
			2,3			2.8		
			M,D,P,L,R,F		1			1.2
		V _{IN} = -35 V <u>8/</u>	1			0.7		
			2,3			2.0		
Ripple rejection	ΔV _{IN} / ΔV _{OUT}	f = 120 Hz, ΔV _{IN} = 10 V	4	01	56		dB	
			M,D,P,L,R,F		4	56		
			5,6 <u>10/</u>			53		

See footnotes at end of table.

STANDARD MICROCIRCUIT DRAWING DEFENSE SUPPLY CENTER COLUMBUS COLUMBUS, OHIO 43218-3990	SIZE A		5962-88747
		REVISION LEVEL G	SHEET 6

TABLE I. Electrical performance characteristics - Continued.

Test	Symbol	Conditions <u>1/ 2/ 3/</u> -55°C ≤ T _A ≤ +125°C unless otherwise specified	Group A subgroups	Device type	Limits		Unit
					Min	Max	
Output noise <u>10/</u> voltage	N _O	f = 10 Hz to 100 kHz, T _A = +25°C	7	01		40	μV / V _{rms}
Long term stability <u>10/</u>	ΔV _{OUT} / Δt	t = 1,000 hours, T _A = +25°C	7	01		120	mV

- 1/ Devices supplied to this drawing have been characterized through all levels M, D, P, L, R, F of irradiation. However, this device is only tested at the "F" level. Pre and Post irradiation values are identical unless otherwise specified in table I. When performing post irradiation electrical measurements for any RHA level, T_A = +25°C.
- 2/ These parts may be dose rate sensitive in a space environment and may demonstrate enhanced low dose rate effects. Radiation end point limits for the noted parameters are guaranteed only for the conditions specified in MIL-STD-883, method 1019, condition A.
- 3/ Unless otherwise specified, V_{IN} = -19 V and I_O = 500 mA for cases M, N, T, U, Y, Z, 4, and 5. V_{IN} = -19 V and I_O = 100 mA for cases X and 2. Maximum test current for cases X and 2 is 500 mA.
- 4/ For cases X and 2: I_O = 5 mA to 500 mA, P ≤ 2 W. For case Y: I_O = 5 mA to 1.0 A, P ≤ 20 W. For cases M, N, T, U, Z, 4, and 5: I_O = 5 mA to 1.0 A, P ≤ 15 W.
- 5/ All measurements except output noise voltage and ripple rejection are made at constant junction temperature and with low duty cycle.
- 6/ Minimum load current for full line regulation is 5.0 mA.
- 7/ For cases M, N, T, U, Y, Z, 4, and 5 only.
- 8/ For cases X and 2 only.
- 9/ Short circuit protection is only assured up to V_{IN} = -35 V.
- 10/ Guaranteed, if not tested, to the limits specified.

3.4 Electrical test requirements. The electrical test requirements shall be the subgroups specified in table II. The electrical tests for each subgroup are described in table I.

3.5 Marking. Marking shall be in accordance with MIL-PRF-38535, appendix A. The part shall be marked with the PIN listed in 1.2 herein. In addition, the manufacturer's PIN may also be marked. For packages where marking of the entire SMD PIN number is not feasible due to space limitations, the manufacturer has the option of not marking the "5962-" on the device. For RHA product using this option, the RHA designator shall still be marked.

3.5.1 Certification/compliance mark. A compliance indicator "C" shall be marked on all non-JAN devices built in compliance to MIL-PRF-38535, appendix A. The compliance indicator "C" shall be replaced with a "Q" or "QML" certification mark in accordance with MIL-PRF-38535 to identify when the QML flow option is used.

3.6 Certificate of compliance. A certificate of compliance shall be required from a manufacturer in order to be listed as an approved source of supply in MIL-HDBK-103 (see 6.6 herein). The certificate of compliance submitted to DSCC-VA prior to listing as an approved source of supply shall affirm that the manufacturer's product meets the requirements of MIL-PRF-38535, appendix A and the requirements herein.

3.7 Certificate of conformance. A certificate of conformance as required in MIL-PRF-38535, appendix A shall be provided with each lot of microcircuits delivered to this drawing.

STANDARD MICROCIRCUIT DRAWING DEFENSE SUPPLY CENTER COLUMBUS COLUMBUS, OHIO 43218-3990	SIZE A		5962-88747
		REVISION LEVEL G	SHEET 7

Case outline M

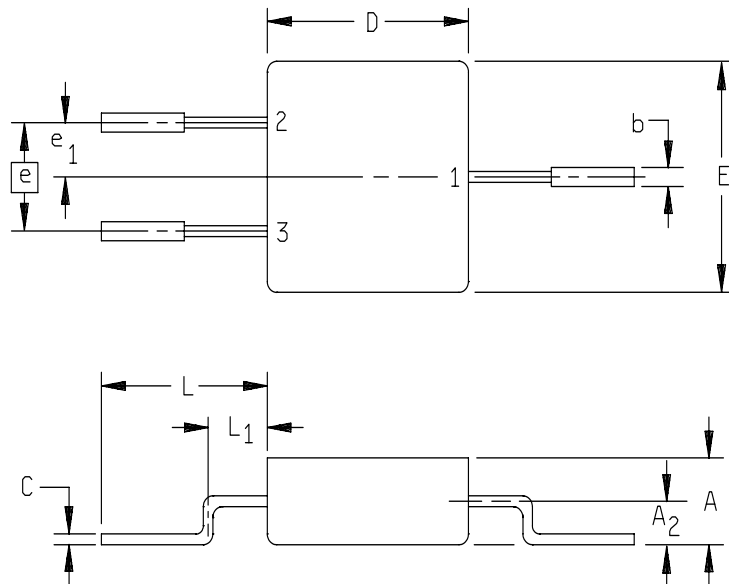

Symbol	Inches		Millimeters	
	Min	Max	Min	Max
A	.160	---	4.06	---
A ₂	.080	---	2.03	---
b	---	.035	---	0.89
C	.020	---	0.51	---
D	---	.425	---	10.8
E	---	.425	---	10.8
e	.200 BSC		5.08 BSC	
e ₁	.100 BSC		2.54 BSC	
L	.350	---	8.89	---
L ₁	---	.135	---	3.43

NOTES:

1. The U.S. government preferred system of measurement is the metric SI system. However, since this item was originally designed using inch-pound units of measurement, in the event of conflict between the metric and inch-pound units, the inch-pound units shall take precedence.
2. Dimensions shall be measured in inches.
3. Metric equivalents are given for general information only.
4. Three leads.

FIGURE 1. Case outlines.

STANDARD MICROCIRCUIT DRAWING DEFENSE SUPPLY CENTER COLUMBUS COLUMBUS, OHIO 43218-3990	SIZE A		5962-88747
		REVISION LEVEL G	SHEET 8

Case outlines T and U

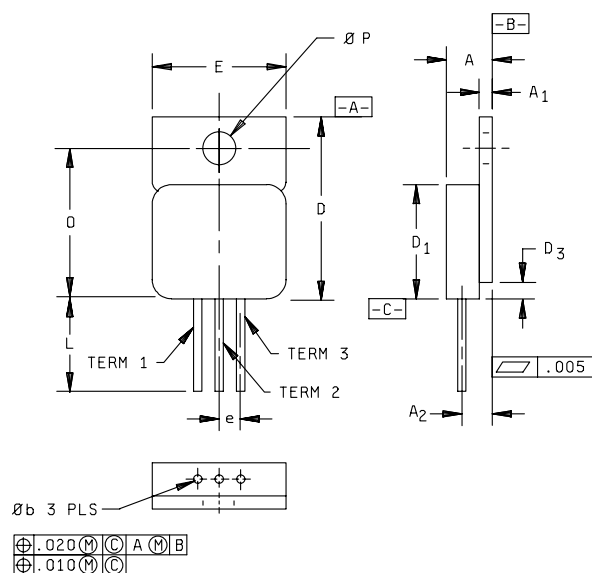

Inches	mm
.005	0.13
.010	0.25
.020	0.51

Letter	Inches		Millimeters	
	Min	Max	Min	Max
A	.190	.200	4.83	5.08
A1	.035	.045	0.89	1.14
A2	.120 BSC		3.05 BSC	
ϕb	.025	.035	0.64	0.89
D	.645	.665	16.38	16.89
D1	.410	.430	10.41	10.92
D3	.000	.065	0.00	1.65
e	.100 BSC		2.54 BSC	
E	.410	.422	10.41	10.71
L	.500	.750	12.70	19.05
O	.527	.537	13.39	16.64
ϕP	.140	.150	3.56	3.81

NOTES:

1. The U.S. government preferred system of measurement is the metric SI system. However, since this item was originally designed using inch-pound units of measurement, in the event of conflict between the metric and inch-pound units, the inch-pound units shall take precedence.
2. For case outlines T and U only, CAGE 34333, the ceramic seal that protrudes from the seating plane is not to be considered in overall package dimensions. The ceramic seal protrusion is considered uncontrolled within an area 30 mils from the seating plane.

FIGURE 1. Case outlines. - Continued.

STANDARD MICROCIRCUIT DRAWING DEFENSE SUPPLY CENTER COLUMBUS COLUMBUS, OHIO 43218-3990	SIZE A		5962-88747
		REVISION LEVEL G	SHEET 9

Case outline X

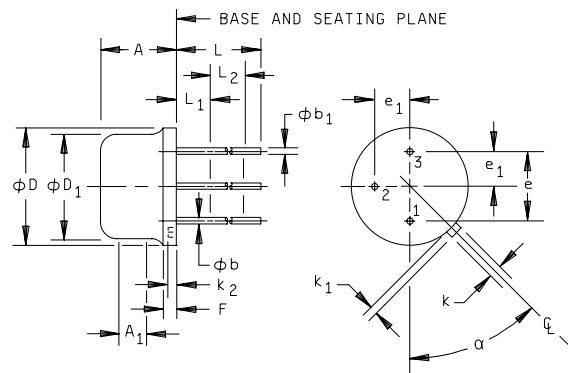

Letter	Inches		Millimeters		Notes
	Min	Max	Min	Max	
A	.165	.185	4.19	4.70	
A1	.100 TP		2.54 T.P.		
phi b	.016	.019	0.41	0.48	2
phi b1	.016	.021	0.41	0.53	2
phi D	.335	.370	8.51	9.40	
phi D1	.305	.335	7.75	8.51	
e	.200 T.P.		5.08 T.P.		4
e1	.100 T.P.		2.54 T.P.		4
F		.050		1.27	
k	.028	.034	0.71	0.86	
k1	.029	.045	0.74	1.14	3
k2	.009	.041	0.23	1.04	
L	.500		12.70		
L1		.050		1.27	
L2	.250		6.35		
alpha	45° T.P.		45° T.P.		

NOTES:

1. The U.S. government preferred system of measurement is the metric SI system. However, since this item was originally designed using inch-pound units of measurement, in the event of conflict between the metric and inch-pound units, the inch-pound units shall take precedence.
2. (All leads) phi b applies between the L1 and L2. phi b1 applies between the L2 and .500 inch (12.70 mm) from the reference plane. Diameter is uncontrolled in L1 and beyond .500 inch (12.70 mm) from the reference plane.
3. Measured from the maximum diameter of the product.
4. Leads having a maximum diameter of .019 inch (0.48 mm) measured in gauging plane .054 inch (1.37 mm) + .001 inch (0.03 mm) - .000 inch (0.00 mm) below the base plane of the product shall be within .007 inch (0.18 mm) of their true-position relative to a maximum width tab.
5. The product may be measured by direct methods or by gauge.

FIGURE 1. Case outlines – Continued.

STANDARD MICROCIRCUIT DRAWING DEFENSE SUPPLY CENTER COLUMBUS COLUMBUS, OHIO 43218-3990	SIZE A		5962-88747
		REVISION LEVEL G	SHEET 10

Case outline Y

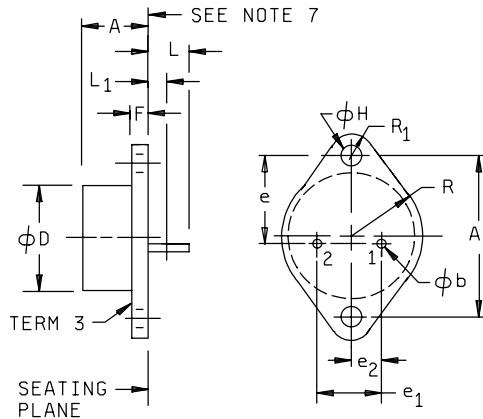

Letter	Inches		Millimeters		Notes
	Min	Max	Min	Max	
A	.250	.450	6.35	11.43	
A1	1.177	1.197	29.90	30.40	
phi b	.038	.043	0.97	1.09	2, 6
phi D		.875		22.22	
e	.655	.675	16.64	17.14	4
e1	.420	.440	10.67	11.16	4
e2	.205	.225	5.21	5.72	
F	.060	.135	1.52	3.43	
phi H	.151	.161	3.84	4.09	4, 5
L	.312	.500	7.92	12.70	3
L1		.050		1.27	2, 3
R	.495	.525	12.57	13.34	
R1	.131	.188	3.33	4.78	

NOTES:

1. The U.S. government preferred system of measurement is the metric SI system. However, since this item was originally designed using inch-pound units of measurement, in the event of conflict between the metric and inch-pound units, the inch-pound units shall take precedence.
2. (Two leads) phi b applies between the L1 and .500 inch (12.70 mm) from the seating plane. Diameter is uncontrolled in L1 and beyond .500 inch (12.70 mm) from the seating plane.
3. Two leads.
4. Two holes.
5. Two holes located at true position within diameter .010 inch (0.25 mm).
6. Leads having a maximum diameter of .043 inch (1.09 mm) measured in gauging plane .054 inch (1.37 mm) + .001 inch (0.03 mm) - .000 inch (0.00 mm) below the seating plane shall be located at true-position within diameter .014 inch (0.36 mm)
7. The mounting surface of the header shall be flat to convex within .003 inch (0.08 mm) inside a .930 inch (23.62 mm) diameter circle on the center of the header and flat to convex within .006 inch (0.15 mm) overall.

FIGURE 1. Case outlines - Continued.

STANDARD MICROCIRCUIT DRAWING DEFENSE SUPPLY CENTER COLUMBUS COLUMBUS, OHIO 43218-3990	SIZE A		5962-88747
		REVISION LEVEL G	SHEET 11

Case outline 4

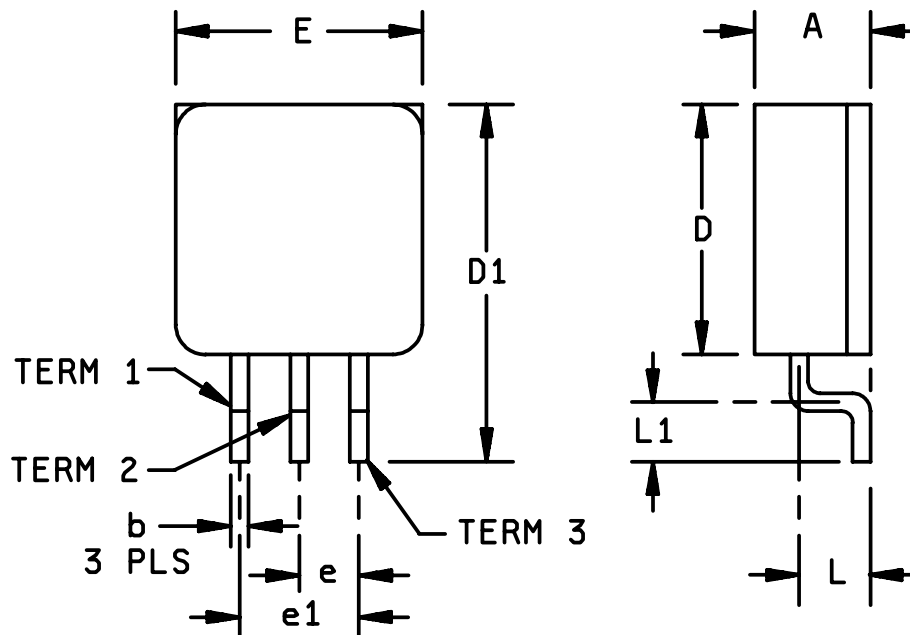

Symbol	Inches		Millimeters	
	Min	Max	Min	Max
A	.190	.210	4.83	5.33
b	---	.030	---	0.76
D	.410	.430	10.41	10.92
D1	.580	.610	14.73	15.49
e	---	.100	---	2.54
e1	---	.200	---	5.08
E	.410	.420	10.41	10.67
L1	.090	.110	2.29	2.79
L	.115	.125	2.92	3.18
N	3		3	

NOTE:

The U.S. government preferred system of measurement is the metric SI system. However, since this item was originally designed using inch-pound units of measurement, in the event of conflict between the metric and inch-pound units, the inch-pound units shall take precedence.

FIGURE 1. Case outline – Continued.

STANDARD MICROCIRCUIT DRAWING DEFENSE SUPPLY CENTER COLUMBUS COLUMBUS, OHIO 43218-3990	SIZE A		5962-88747
		REVISION LEVEL G	SHEET 12

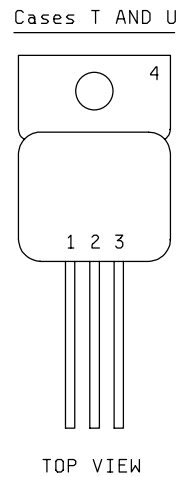
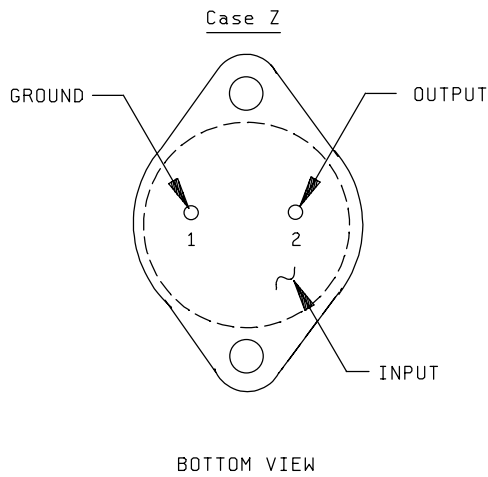
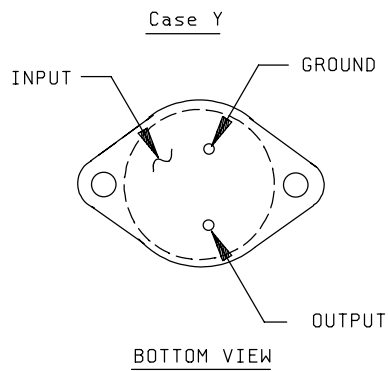
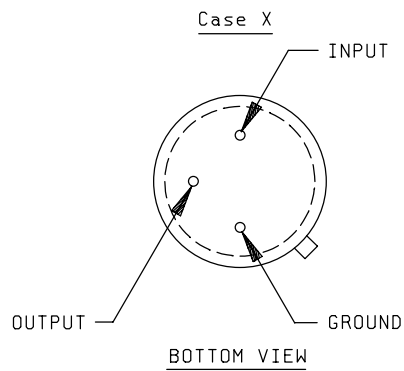

Case T

- 1 - GROUND
- 2 - INPUT
- 3 - OUTPUT
- 4 - INPUT

Case U

- 1 - GROUND
- 2 - INPUT
- 3 - OUTPUT
- 4 - NC

FIGURE 2. Terminal connections.

STANDARD MICROCIRCUIT DRAWING DEFENSE SUPPLY CENTER COLUMBUS COLUMBUS, OHIO 43218-3990	SIZE A		5962-88747
		REVISION LEVEL G	SHEET 13

Device type	01				
Case outlines	M	N	2	4	5
Terminal number	Terminal symbol				
1	V _{OUT}	OUTPUT	NC	GROUND	OUTPUT
2	ADJUST	GROUND	V _{IN}	INPUT	GROUND
3	V _{IN}	INPUT	NC	OUTPUT	INPUT
4	ISOLATED (CASE)	---	V _{OUT}	ISOLATED (CASE)	---
5	---	---	V _{OUT}	---	---
6	---	---	NC	---	---
7	---	---	V _{OUT}	---	---
8	---	---	NC	---	---
9	---	---	NC	---	---
10	---	---	NC	---	---
11	---	---	NC	---	---
12	---	---	NC	---	---
13	---	---	NC	---	---
14	---	---	NC	---	---
15	---	---	GROUND	---	---
16	---	---	NC	---	---
17	---	---	GROUND	---	---
18	---	---	NC	---	---
19	---	---	NC	---	---
20	---	---	V _{IN}	---	---

NC = No connection

FIGURE 2. Terminal connections. – Continued.

STANDARD MICROCIRCUIT DRAWING DEFENSE SUPPLY CENTER COLUMBUS COLUMBUS, OHIO 43218-3990	SIZE A		5962-88747
		REVISION LEVEL G	SHEET 14

Case outline U

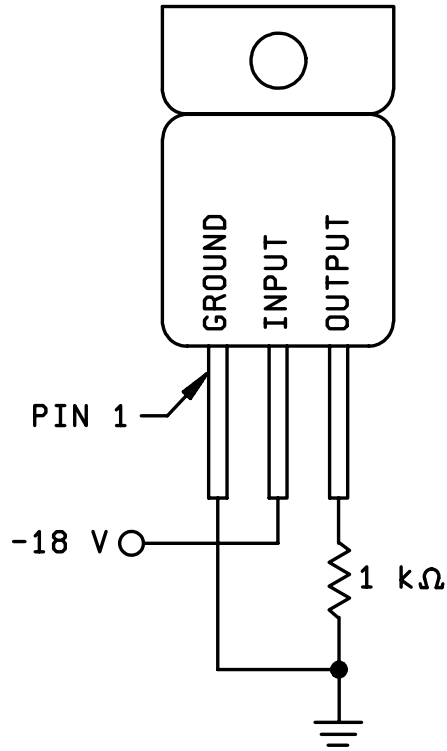

FIGURE 3. Radiation exposure circuit.

STANDARD MICROCIRCUIT DRAWING DEFENSE SUPPLY CENTER COLUMBUS COLUMBUS, OHIO 43218-3990	SIZE A		5962-88747
		REVISION LEVEL G	SHEET 15

3.8 Notification of change. Notification of change to DSCC-VA shall be required for any change that affects this drawing.

3.9 Verification and review. DSCC, DSCC's agent, and the acquiring activity retain the option to review the manufacturer's facility and applicable required documentation. Offshore documentation shall be made available onshore at the option of the reviewer.

4. VERIFICATION

4.1 Sampling and inspection. Sampling and inspection procedures shall be in accordance with MIL-PRF-38535, appendix A.

4.2 Screening. Screening shall be in accordance with method 5004 of MIL-STD-883, and shall be conducted on all devices prior to quality conformance inspection. The following additional criteria shall apply:

a. Burn-in test, method 1015 of MIL-STD-883.

(1) Test condition A, B, C, or D. The test circuit shall be maintained by the manufacturer under document revision level control and shall be made available to the preparing or acquiring activity upon request. The test circuit shall specify the inputs, outputs, biases, and power dissipation, as applicable, in accordance with the intent specified in method 1015 of MIL-STD-883.

(2) $T_A = +125^{\circ}\text{C}$, minimum.

b. Interim and final electrical test parameters shall be as specified in table II herein, except interim electrical parameter tests prior to burn-in are optional at the discretion of the manufacturer.

4.3 Quality conformance inspection. Quality conformance inspection shall be in accordance with method 5005 of MIL-STD-883 including groups A, B, C, and D inspections. The following additional criteria shall apply.

4.3.1 Group A inspection.

a. Tests shall be as specified in table II herein.

b. Subgroups 8, 9, 10, and 11 in table I, method 5005 of MIL-STD-883 shall be omitted.

4.3.2 Groups C and D inspections.

a. End-point electrical parameters shall be as specified in table II herein.

b. Steady-state life test conditions, method 1005 of MIL-STD-883.

(1) Test condition A, B, C, or D. The test circuit shall be maintained by the manufacturer under document revision level control and shall be made available to the preparing or acquiring activity upon request. The test circuit shall specify the inputs, outputs, biases, and power dissipation, as applicable, in accordance with the intent specified in method 1005 of MIL-STD-883.

(2) $T_A = +125^{\circ}\text{C}$, minimum.

(3) Test duration: 1,000 hours, except as permitted by method 1005 of MIL-STD-883.

4.3.3 Group E inspection. Group E inspection is required only for parts intended to be marked as radiation hardness assured (see 3.5 herein). RHA levels shall be as specified in MIL-PRF-38535 or MIL-PRF-38535, Appendix A. End-point parameters shall be as specified in table II herein.

4.3.3.1 Total dose irradiation testing. Total dose irradiation testing shall be performed in accordance with MIL-STD-883 method 1019, condition A and as specified herein.

STANDARD MICROCIRCUIT DRAWING DEFENSE SUPPLY CENTER COLUMBUS COLUMBUS, OHIO 43218-3990	SIZE A		5962-88747
		REVISION LEVEL G	SHEET 16

TABLE II. Electrical test requirements.

MIL-STD-883 test requirements	Subgroups (in accordance with MIL-STD-883, method 5005, table I)
Interim electrical parameters (method 5004)	1
Final electrical test parameters (method 5004)	1*,2,3,4
Group A test requirements (method 5005)	1,2,3,4,5**,6**,7**
Groups C and D end-point electrical parameters (method 5005)	1
Group E end-point electrical parameters (method 5005)	1,4

* PDA applies to subgroup 1.

** Subgroups 5, 6, and 7 if not tested, shall be guaranteed to the limits specified in table I.

5. PACKAGING

5.1 Packaging requirements. The requirements for packaging shall be in accordance with MIL-PRF-38535, appendix A.

6. NOTES

6.1 Intended use. Microcircuits conforming to this drawing are intended for use for Government microcircuit applications (original equipment), design applications, and logistics purposes.

6.2 Replaceability. Microcircuits covered by this drawing will replace the same generic device covered by a contractor-prepared specification or drawing.

6.3 Configuration control of SMD's. All proposed changes to existing SMD's will be coordinated with the users of record for the individual documents. This coordination will be accomplished using DD Form 1692, Engineering Change Proposal.

6.4 Record of users. Military and industrial users shall inform Defense Supply Center Columbus (DSCC) when a system application requires configuration control and the applicable SMD. DSCC will maintain a record of users and this list will be used for coordination and distribution of changes to the drawings. Users of drawings covering microelectronics devices (FSC 5962) should contact DSCC-VA, telephone (614) 692-0544.

6.5 Comments. Comments on this drawing should be directed to DSCC-VA, Columbus, Ohio 43218-3990, or telephone (614) 692-0547.

6.6 Approved sources of supply. Approved sources of supply are listed in MIL-HDBK-103. The vendors listed in MIL-HDBK-103 have agreed to this drawing and a certificate of compliance (see 3.6 herein) has been submitted to and accepted by DSCC-VA.

STANDARD MICROCIRCUIT DRAWING DEFENSE SUPPLY CENTER COLUMBUS COLUMBUS, OHIO 43218-3990	SIZE A		5962-88747
		REVISION LEVEL G	SHEET 17

STANDARD MICROCIRCUIT DRAWING BULLETIN

DATE: 06-01-23

Approved sources of supply for SMD 5962-88747 are listed below for immediate acquisition information only and shall be added to MIL-HDBK-103 and QML-38535 during the next revision. MIL-HDBK-103 and QML-38535 will be revised to include the addition or deletion of sources. The vendors listed below have agreed to this drawing and a certificate of compliance has been submitted to and accepted by DSCC-VA. This information bulletin is superseded by the next dated revision of MIL-HDBK-103 and QML-38535. DSCC maintains an online database of all current sources of supply at <http://www.dscclia.mil/Programs/Smcr/>.

Standard microcircuit drawing PIN <u>1</u> /	Vendor CAGE number	Vendor similar PIN <u>2</u> /
5962-8874701MA	69210	OM1912SMM/883B
5962-8874701NA	21845	SDP7912ANMD
	69210	OM1912NMM/883B
5962-8874701TA	U3158	IP7912AG-DESC
	21845	SDP7912ATMD
	69210	OM7912AH/883B
	34333	SG7912AG/883B
5962-8874701UA	U3158	IP7912AIG-DESC
	21845	SDP7912AUMD
	<u>3</u> /	FM912S7
	34333	SG7912AIG/883B
	69210	OM1912STM/883B
5962-8874701XA	U3158	IP79M12AH-DESC
	34333	SG7912AT/883B
5962-8874701YA	U3158	IP7912AK-DESC
	34333	SG7912AK/883B
	69210	OM1912NK/883B

STANDARD MICROCIRCUIT DRAWING BULLETIN - CONTINUED

Standard microcircuit drawing PIN <u>1/</u>	Vendor CAGE number	Vendor similar PIN <u>2/</u>
5962-8874701ZA	U3158	IP7912AR-DESC
	21845	SDP7912AZMD
	34333	SG7912AR/883B
5962-88747012A	21845	SDP7912A2MD
	34333	SG7912AL/883B
	69210	OM1912N2/883B
5962-88747014A	69210	OM1912SRM/883B
5962-88747015A	69210	OM1912N5M/883B
5962F8874701UA	<u>3/</u>	OMR1912STM/883B

1/ The lead finish shown for each PIN representing a hermetic package is the most readily available from the manufacturer listed for that part. If the desired lead finish is not listed contact the vendor to determine its availability.

2/ Caution. Do not use this number for item acquisition. Items acquired to this number may not satisfy the performance requirements of this drawing.

3/ Not available from an approved source of supply.

Vendor CAGE number

Vendor name and address

U3158

Semelab PLC
Coventry Road, Lutterworth
Leicestershire LE174JB
United Kingdom

21845

Solitron Devices Incorporated
3301 Electronics Way
West Palm Beach, FL 33407-4697

34333

Microsemi Integrated Products
11861 Western Avenue
Garden Grove, CA 92841-1816

69210

International Rectifier
205 Crawford Street
Leominster, MA 01453-2353

The information contained herein is disseminated for convenience only and the Government assumes no liability whatsoever for any inaccuracies in the information bulletin.