

CHIP COIL (CHIP INDUCTORS) LQW2UAS□□□□0CL REFERENCE SPECIFICATION

1. Scope

This reference specification applies to LQW2UAS_0C series, Chip coil (Chip Inductors).

2. Part Numbering

(ex)	LQ	W	2U	A	S	12N	G	0	C	L
	Product ID	Structure	Dimension (L×W)	Applications and Characteristics	Category	Inductance	Tolerance	Features	Electrode	Packaging L:Taping *B: Bulk

*Bulk packing also available. (A product is put in the plastic bag under the taping conditions.)

3. Rating

- Operating Temperature Range
(Ambient temperature; Self-temperature rise is not included) $-40^{\circ}\text{C} \sim +85^{\circ}\text{C}$
- Storage Temperature Range. $-40^{\circ}\text{C} \sim +85^{\circ}\text{C}$

Customer Part Number	MURATA Part Number	Inductance		Q (min.)	DC Resistance (Ω max.)	Self Resonant Frequency (MHz min.)	Rated Current (mA)
		(nH)	Tolerance				
	LQW2UAS12NG0CL	12	G : ±2% J : ±5%	50	0.09	3300	1000
	LQW2UAS12NJ0CL						
	LQW2UAS18NG0CL	18	G : ±2% J : ±5%	55	0.11	2500	
	LQW2UAS18NJ0CL						
	LQW2UAS22NF0CL	22	F : ±1% G : ±2% J : ±5%	55	0.12	2400	
	LQW2UAS22NG0CL						
	LQW2UAS22NJ0CL						
	LQW2UAS27NG0CL	27	G : ±2% J : ±5%	60	0.13	1600	
	LQW2UAS27NJ0CL						
	LQW2UAS33NF0CL	33	F : ±1% G : ±2% J : ±5%	60	0.14	1500	
	LQW2UAS33NG0CL						
	LQW2UAS33NJ0CL						
	LQW2UAS39NF0CL	39	F : ±1% G : ±2% J : ±5%	65	0.15	1300	
	LQW2UAS39NG0CL						
	LQW2UAS39NJ0CL						
	LQW2UAS47NF0CL	47	F : ±1% G : ±2% J : ±5%	65	0.16	1000	
	LQW2UAS47NG0CL						
	LQW2UAS47NJ0CL						
	LQW2UAS56NF0CL	56	F : ±1% G : ±2% J : ±5%	65	0.18	1000	
	LQW2UAS56NG0CL						
	LQW2UAS56NJ0CL						
	LQW2UAS68NF0CL	68	F : ±1% G : ±2% J : ±5%	60	0.20	950	
	LQW2UAS68NG0CL						
	LQW2UAS68NJ0CL						
	LQW2UAS82NF0CL	82	F : ±1% G : ±2% J : ±5%	60	0.22	650	
	LQW2UAS82NG0CL						
	LQW2UAS82NJ0CL						
	LQW2UASR10F0CL	100	F : ±1% G : ±2% J : ±5%	45	0.56	850	
	LQW2UASR10G0CL						
	LQW2UASR10J0CL						
	LQW2UASR12F0CL	120	F : ±1% G : ±2% J : ±5%	45	0.63	580	
	LQW2UASR12G0CL						
	LQW2UASR12J0CL						
	LQW2UASR15F0CL	150	F : ±1% G : ±2% J : ±5%	45	0.70	580	
	LQW2UASR15G0CL						
	LQW2UASR15J0CL						

Customer Part Number	MURATA Part Number	Inductance		Q (min.)	DC Resistance (Ω max.)	Self Resonant Frequency (MHz min.)	Rated Current (mA)
		(nH)	Tolerance				
	LQW2UASR18F0CL	180		45	0.77	750	620
	LQW2UASR18G0CL						
	LQW2UASR18J0CL						
	LQW2UASR22F0CL	220		45	0.84	700	500
	LQW2UASR22G0CL						
	LQW2UASR22J0CL						
	LQW2UASR27F0CL	270		45	0.91	600	500
	LQW2UASR27G0CL						
	LQW2UASR27J0CL						
	LQW2UASR33F0CL	330		45	1.05	570	450
	LQW2UASR33G0CL						
	LQW2UASR33J0CL						
	LQW2UASR39F0CL	390		45	1.12	500	470
	LQW2UASR39G0CL						
	LQW2UASR39J0CL						
	LQW2UASR47F0CL	470		45	1.19	450	470
	LQW2UASR47G0CL						
	LQW2UASR47J0CL						
	LQW2UASR56F0CL	560		45	1.33	415	400
	LQW2UASR56G0CL						
	LQW2UASR56J0CL						
	LQW2UASR62F0CL	620		45	1.40	375	300
	LQW2UASR62G0CL						
	LQW2UASR62J0CL						
	LQW2UASR68F0CL	680		45	1.47	400	400
	LQW2UASR68G0CL						
	LQW2UASR68J0CL						
	LQW2UASR75F0CL	750		45	1.54	360	360
	LQW2UASR75G0CL						
	LQW2UASR75J0CL						
	LQW2UASR82F0CL	820		45	1.61	350	400
	LQW2UASR82G0CL						
	LQW2UASR82J0CL						
	LQW2UASR91F0CL	910		45	1.68	320	380
	LQW2UASR91G0CL						
	LQW2UASR91J0CL						
	LQW2UAS1R0F0CL	1000		35	1.75	290	370
	LQW2UAS1R0G0CL						
	LQW2UAS1R0J0CL						
	LQW2UAS1R2F0CL	1200		35	2.0	210	310
	LQW2UAS1R2G0CL						
	LQW2UAS1R2J0CL						
	LQW2UAS1R5G0CL	1500		28	2.3	120	330
	LQW2UAS1R5J0CL						
	LQW2UAS1R8G0CL	1800		28	2.6	140	300
	LQW2UAS1R8J0CL						
	LQW2UAS2R2G0CL	2200		28	2.8	130	280
	LQW2UAS2R2J0CL						

F : $\pm 1\%$
G : $\pm 2\%$
J : $\pm 5\%$

G : $\pm 2\%$
J : $\pm 5\%$

Customer Part Number	MURATA Part Number	Inductance		Q (min.)	DC Resistance (Ω max.)	Self Resonant Frequency (MHz min.)	Rated Current (mA)
		(nH)	Tolerance				
	LQW2UAS2R7G0CL	2700	G : ±2% J : ±5%	22	3.2	110	290
	LQW2UAS2R7J0CL						
	LQW2UAS3R3G0CL	3300		22	3.4	90	290
	LQW2UAS3R3J0CL						
	LQW2UAS3R9G0CL	3900		20	3.6	70	260
	LQW2UAS3R9J0CL						
	LQW2UAS4R7G0CL	4700	20	4.0	60	260	
	LQW2UAS4R7J0CL						
	LQW2UAS5R6J0CL	5600	J : ±5%	16	4.0	20	240
	LQW2UAS6R8J0CL	6800		18	4.9	40	200
	LQW2UAS8R2J0CL	8200		18	6.0	25	170

4. Testing Conditions

《Unless otherwise specified》

Temperature : Ordinary Temperature / 15°C to 35°C
 Humidity : Ordinary Humidity / 25%(RH) to 85%(RH)

《In case of doubt》

Temperature : 20°C±2°C
 Humidity : 60%(RH) to 70%(RH)
 Atmospheric Pressure : 86kPa to 106 kPa

5. Appearance and Dimensions

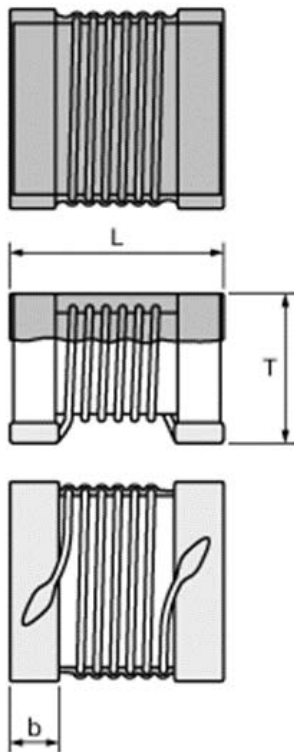

■ Unit Mass (Typical value)
 0.039g

L	2.62±0.3
W	2.45±0.2
T	1.83±0.2
a	2.45±0.2
b	0.6±0.15
e1	0.25±0.15

(in mm)

6. Electrical Performance

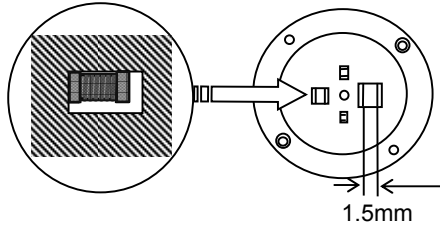
No.	Item	Specification	Test Method
6.1	Inductance	Inductance shall meet item 3.	Measuring Equipment : KEYSIGHT E4991A or equivalent Measuring Frequency : <Inductance> 50MHz/ 12nH ~ 82nH 25MHz/ 100nH ~ 1000nH 7.9MHz/ 1200nH ~ 6800nH 2.5MHz/ 8200nH <Q> 500MHz/ 12nH 350MHz/ 18nH ~ 120nH 100MHz/ 150nH ~ 820nH 50MHz/ 910nH ~ 2200nH 25MHz/ 2700nH ~ 4700nH 7.9MHz/ 5600nH ~ 8200nH Measuring Condition : Test signal level / about 0dBm Electrode spaces / 1.5mm Electrical length / 10.0mm Weight / about 1N~3N Measuring Fixture : KEYSIGHT E4991A Position coil under test as shown in below and contact coil with each terminal by adding weight.  Measuring Method : See the endnote. <Electrical Performance : Measuring Method of Inductance/Q>
6.2	Q	Q shall meet item 3.	
6.3	DC Resistance	DC Resistance shall meet item 3.	Measuring Equipment:Digital multi meter
6.4	Self Resonant Frequency(SRF)	S.R.F shall meet item 3.	Measuring Equipment: KEYSIGHT N5230C or equivalent
6.5	Rated Current	Self temperature rise shall be limited to 40°C max.	The rated current is applied.

9. Specification of Packaging

9.1 Appearance and Dimensions of plastic tape (8mm-wide, 4mm-pitch)

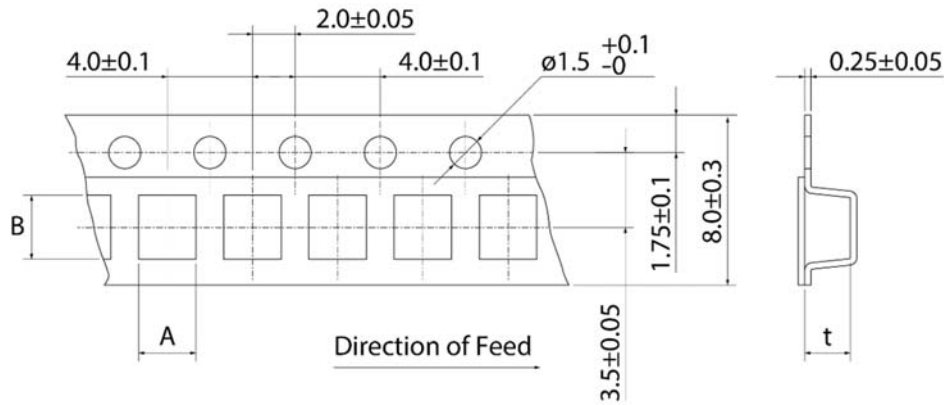

·Dimension of the Cavity is measured at the bottom side.

A	(2.7)
B	(2.9)
t	(2.15)

(in mm)

9.2 Specification of Taping

- (1) Packing quantity (standard quantity)
2,000 pcs / reel
- (2) Packing Method
Products shall be packed in the each embossed cavity of plastic tape and sealed by cover tape.
- (3) Sprocket hole
Sprocket holes are to the right as the tape is pulled toward the user.
- (4) Spliced point
Plastic tape and Cover tape has no spliced point.
- (5) Missing components number
Missing components number within 0.1 % of the number per reel or 1 pc., whichever is greater, and are not continuous. The specified quantity per reel is kept.

9.3 Pull Strength

Plastic tape	5N min.
Cover tape	10N min.

9.4 Peeling off force of cover tape

Speed of Peeling off	300mm / min
Peeling off force	0.1N to 0.6N (minimum value is typical)

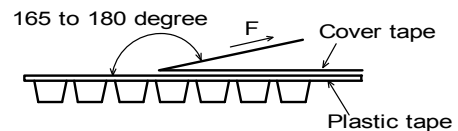

9.5 Dimensions of Leader-tape,Trailer and Reel

There shall be leader-tape (top tape and empty tape) and trailer-tape (empty tape) as follows.

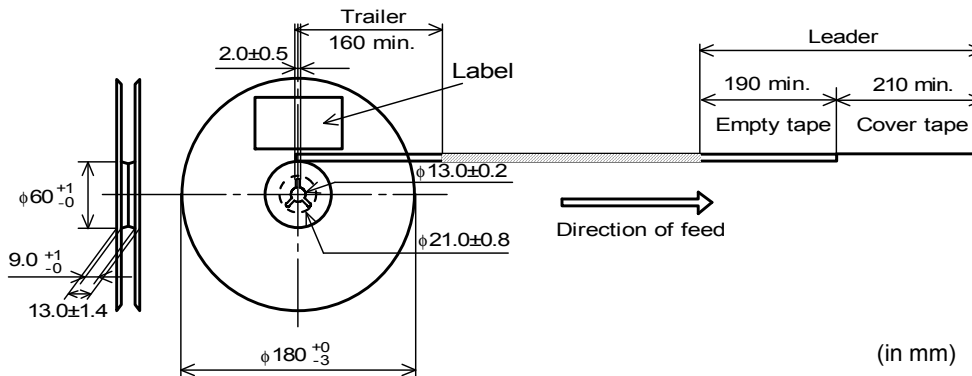

(in mm)

11.2 Flux, Solder

- Use rosin-based flux.
Includes middle activator equivalent to 0.06(wt)% to 0.1(wt)% Chlorine.
Don't use highly acidic flux with halide content exceeding 0.2(wt)% (chlorine conversion value).
Don't use water-soluble flux.
- Use Sn-3.0Ag-0.5Cu solder.
- Standard thickness of solder paste : 100 μ m to 150 μ m.

11.3 Reflow soldering conditions

- Pre-heating should be in such a way that the temperature difference between solder and product surface is limited to 150°C max. Cooling into solvent after soldering also should be in such a way that the temperature difference is limited to 100°C max.
Insufficient pre-heating may cause cracks on the product, resulting in the deterioration of products quality.
- Standard soldering profile and the limit soldering profile is as follows.
The excessive limit soldering conditions may cause leaching of the electrode and / or resulting in the deterioration of product quality.
- Reflow soldering profile

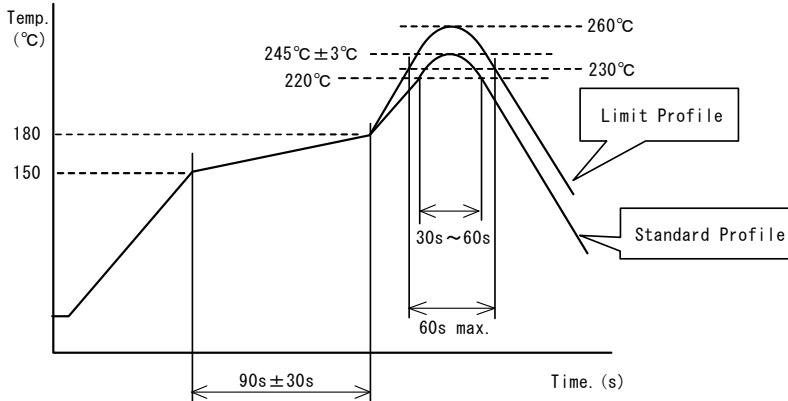

	Standard Profile	Limit Profile
Pre-heating	150°C~180°C , 90s±30s	
Heating	above 220°C, 30s~60s	above 230°C, 60s max.
Peak temperature	245°C±3°C	260°C, 10s
Cycle of reflow	2 times	2 times

11.4 Reworking with soldering iron

The following conditions must be strictly followed when using a soldering iron.

Pre-heating	150°C, 1 min
Tip temperature	350°C max.
Soldering iron output	80W max.
Tip diameter	φ3mm max.
Soldering time	3(+1,-0)s
Time	2 times

Note : Do not directly touch the products with the tip of the soldering iron in order to prevent the crack on the products due to the thermal shock.

11.5 Solder Volume

- Solder shall be used not to be exceed the upper limits as shown below.
- Accordingly increasing the solder volume, the mechanical stress to Chip is also increased.
Exceeding solder volume may cause the failure of mechanical or electrical performance.

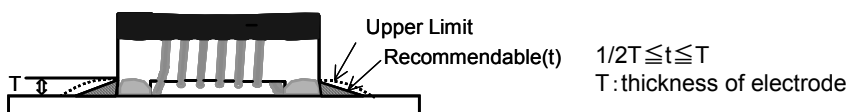

11.6 Product's location

The following shall be considered when designing and laying out P.C.B.'s.

- (1) P.C.B. shall be designed so that products are not subject to the mechanical stress due to warping the board.

[Products direction]

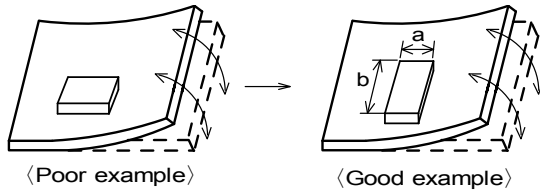

Products shall be located in the sideways direction (Length: $a < b$) to the mechanical stress.

- (2) Components location on P.C.B. separation.

It is effective to implement the following measures, to reduce stress in separating the board.

It is best to implement all of the following three measures; however, implement as many measures as possible to reduce stress.

Contents of Measures	Stress Level
(1) Turn the mounting direction of the component parallel to the board separation surface.	$A > D *1$
(2) Add slits in the board separation part.	$A > B$
(3) Keep the mounting position of the component away from the board separation surface.	$A > C$

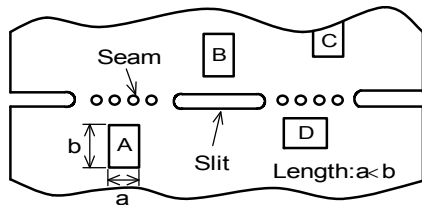

*1 $A > D$ is valid when stress is added vertically to the perforation as with Hand Separation.
If a Cutting Disc is used, stress will be diagonal to the PCB, therefore $A > D$ is invalid.

- (3) Mounting Components Near Screw Holes

When a component is mounted near a screw hole, it may be affected by the board deflection that occurs during the tightening of the screw. Mount the component in a position as far away from the screw holes as possible.

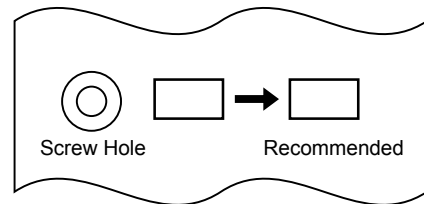

11.7 Cleaning Conditions

Products shall be cleaned on the following conditions.

- (1) Cleaning temperature shall be limited to 60°C max. (40°C max for IPA.)
- (2) Ultrasonic cleaning shall comply with the following conditions with avoiding the resonance phenomenon at the mounted products and P.C.B.
Power : 20 W / l max. Frequency : 28kHz to 40kHz Time : 5 min max.
- (3) Cleaner
 - 1. Alcohol type cleaner
Isopropyl alcohol (IPA)
 - 2. Aqueous agent
PINE ALPHA ST-100S
- (4) There shall be no residual flux and residual cleaner after cleaning.
In the case of using aqueous agent, products shall be dried completely after rinse with de-ionized water in order to remove the cleaner.
- (5) Other cleaning Please contact us.

11.8 Resin coating

The inductance value may change due to high cure-stress of resin to be used for coating/molding products. An open circuit issue may occur by mechanical stress caused by the resin, amount/cured shape of resin, or operating condition etc. Some resin contains some impurities or chloride possible to generate chlorine by hydrolysis under some operating condition may cause corrosion of wire of coil, leading to open circuit. So, please pay your careful attention when you select resin in case of coating/molding the products with the resin. Prior to use the coating resin, please make sure no reliability issue is observed by evaluating products mounted on your board.

11.9 Caution for use

- Sharp material such as a pair of tweezers or other material such as bristles of cleaning brush, shall not be touched to the winding portion to prevent the breaking of wire.
- Mechanical shock should not be applied to the products mounted on the board to prevent the breaking of the core.

11.10 Notice of product handling at mounting

In some mounting machines, when picking up components support pin pushes up the components from the bottom of plastic tape. In this case, please remove the support pin. The support pin may damage the components and break wire.

11.11 Handling of a substrate

After mounting products on a substrate, do not apply any stress to the product caused by bending or twisting to the substrate when cropping the substrate, inserting and removing a connector from the substrate or tightening screw to the substrate.

Excessive mechanical stress may cause cracking in the product.

Bending

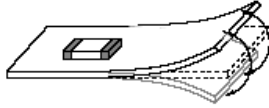

Twisting

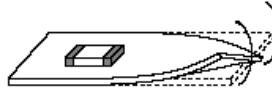
**11.12 Storage and Handling Requirements**

(1) Storage period

Use the products within 12 months after delivered.

Solderability should be checked if this period is exceeded.

(2) Storage conditions

- Products should be stored in the warehouse on the following conditions.

Temperature : -10°C to 40°C

Humidity : 15% to 85% relative humidity No rapid change on temperature and humidity

Don't keep products in corrosive gases such as sulfur, chlorine gas or acid, or it may cause oxidation of electrode, resulting in poor solderability.

- Products should not be stored on bulk packaging condition to prevent the chipping of the core and the breaking of winding wire caused by the collision between the products.
- Products should be stored on the palette for the prevention of the influence from humidity, dust and so on.
- Products should be stored in the warehouse without heat shock, vibration, direct sunlight and so on.

(3) Handling Condition

Care should be taken when transporting or handling product to avoid excessive vibration or mechanical shock.

12. ⚠ Note

- (1) Please make sure that your product has been evaluated in view of your specifications with our product being mounted to your product.
- (2) You are requested not to use our product deviating from the reference specifications.
- (3) The contents of this reference specification are subject to change without advance notice.
Please approve our product specifications or transact the approval sheet for product specifications before ordering.

< Electrical Performance:Measuring Method of Inductance / Q >

To keep compatibility to other vender's product, Inductance and Q value shall be measured in following method.

(1) Residual elements and stray elements of test fixture can be described by F-parameter shown in following.

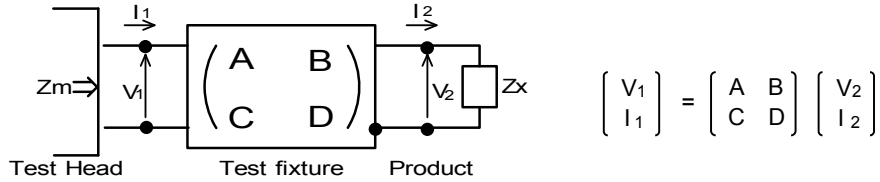

(2) The impedance of chip coil Zx and measured value Zm can be described by input/output current / voltage.

$$Z_m = \frac{V_1}{I_1}, \quad Z_x = \frac{V_2}{I_2}$$

(3) Thus, the relation between Zx and Zm is following;

$$Z_x = \alpha \frac{Z_m - \beta}{1 - Z_m \Gamma} \quad \text{where, } \alpha = D / A = 1$$

$$\beta = B / D = Z_{sm} - (1 - Y_{om} Z_{sm}) Z_{ss}$$

$$\Gamma = C / A = Y_{om}$$

- Z_{sm} : measured impedance of short chip
- Z_{ss} : residual impedance of short chip (=equivalent series Inductance X)
- Y_{om} : measured admittance when opening the fixture

Important : X : Z_{ss} shall be defined as correction value to fit nominal inductance of other venders' products.
Please input X value instead of equivalent series Inductance (ShortL) on test equipment calibration.

(4) Lx and Qx shall be calculated with the following equation.

$$L_x = \frac{\text{Im}(Z_x)}{2\pi f}, \quad Q_x = \frac{\text{Im}(Z_x)}{\text{Re}(Z_x)} \quad f : \text{Measuring frequency}$$

Inductance and Q value shall be measured after this calibration setting.
In addition, Q value should be measured under our standard calibration setting of residual impedance, 0.771nH.

Chart. equivalent series Inductance to fit nominal inductance of other vendors' products.

MURATA Part Number	Inductance	
	X [nH] equivalent series Inductance	Measuring Frequency
LQW2UAS12N_0C	0.511	50
LQW2UAS18N_0C	0.321	50
LQW2UAS22N_0C	0.941	50
LQW2UAS27N_0C	0.651	50
LQW2UAS33N_0C	1.711	50
LQW2UAS39N_0C	0.741	50
LQW2UAS47N_0C	2.071	50
LQW2UAS56N_0C	2.351	50
LQW2UAS68N_0C	2.281	50
LQW2UAS82N_0C	2.921	50
LQW2UASR10_0C	3.351	25
LQW2UASR12_0C	3.871	25
LQW2UASR15_0C	4.371	25
LQW2UASR18_0C	5.271	25
LQW2UASR22_0C	3.271	25
LQW2UASR27_0C	8.871	25
LQW2UASR33_0C	12.771	25
LQW2UASR39_0C	22.271	25
LQW2UASR47_0C	20.971	25
LQW2UASR56_0C	24.971	25
LQW2UASR62_0C	28.371	25
LQW2UASR68_0C	44.271	25
LQW2UASR75_0C	35.371	25
LQW2UASR82_0C	47.171	25
LQW2UASR91_0C	56.371	25
LQW2UAS1R0_0C	79.171	25
LQW2UAS1R2_0C	15.771	7.9
LQW2UAS1R5_0C	5.771	7.9
LQW2UAS1R8_0C	6.771	7.9
LQW2UAS2R2_0C	25.771	7.9
LQW2UAS2R7_0C	63.771	7.9
LQW2UAS3R3_0C	91.771	7.9
LQW2UAS3R9_0C	67.771	7.9
LQW2UAS4R7_0C	163.771	7.9
LQW2UAS5R6_0C	0.771	7.9
LQW2UAS6R8_0C	0.771	7.9
LQW2UAS8R2_0C	0.771	2.5