

LMH6517

LMH6517 Low Power, Low Noise, IF and Baseband, Dual 16 bit ADC Driver With Digitally Controlled Gain



Literature Number: SNOSB19J

LMH6517

Low Power, Low Noise, IF and Baseband, Dual 16 bit ADC Driver With Digitally Controlled Gain

General Description

The LMH6517 contains two high performance, digitally controlled variable gain amplifiers (DVGA). It has been designed for use in narrowband and broadband IF sampling applications. Typically the LMH6517 drives a high performance ADC in a broad range of mixed signal and digital communication applications such as mobile radio and cellular base stations where automatic gain control (AGC) is required to increase system dynamic range.

Each channel of LMH6517 has an independent, digitally controlled attenuator and a high linearity, differential output amplifier. Each block has been optimized for low distortion and maximum system design flexibility. Each channel can be individually disabled for power savings.

The LMH6517 digitally controlled attenuator provides precise 0.5dB gain steps over a 31.5dB range. On chip digital latches are provided for local storage of the gain setting. Both serial and parallel programming options are provided. A Pulse mode is also offered where simple up or down commands can change the gain one step at a time.

The output amplifier has a differential output allowing large signal swings on a single 5V supply. The low impedance output provides maximum flexibility when driving filters or analog to digital converters.

The LMH6517 operates over the industrial temperature range of -40°C to $+85^{\circ}\text{C}$. The LMH6517 is available in a 32-Pin, thermally enhanced, LLP package.

Features

- Accurate, 0.5dB gain steps
- 200Ω Resistive, differential input
- Low impedance, differential output
- Disable function for each channel
- Parallel gain control
- SPI compatible serial bus
- Two wire, Pulse Mode control
- On chip register stores gain setting
- Low sensitivity of linearity and phase to gain setting
- Single 5V supply voltage
- Small footprint LLP package

Key Specifications

- OIP3: 43dBm @ 200MHz
- Noise figure 5.5dB
- Gain step size of 0.5dB
- Gain step accuracy: 0.05dB
- Frequency Range of 1200 MHz
- Supply current 80mA per channel

Applications

- Cellular base stations
- IF sampling receivers
- Instrumentation
- Modems
- Imaging

Typical Application: IF Sampling Receiver

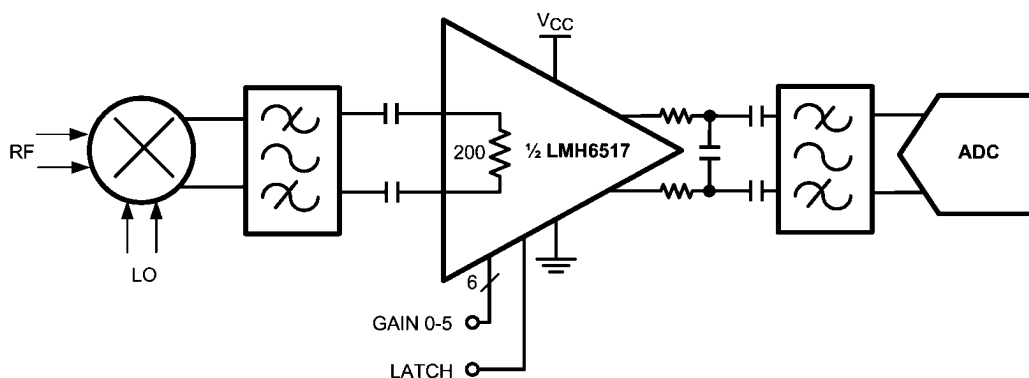

30088101

Absolute Maximum Ratings (Note 1)

If Military/Aerospace specified devices are required, please contact the Texas Instruments Sales Office/ Distributors for availability and specifications.

ESD Tolerance (Note 2)

Human Body Model	2 kV
Machine Model	100V
Charged Device Model	750V
Positive Supply Voltage (Pin 3)	-0.6V to 5.5V
Differential Voltage between Any Two Grounds	<200 mV
Analog Input Voltage Range	-0.6V to V+
Digital Input Voltage Range	-0.6V to 3.6V
Output Short Circuit Duration (one pin to ground)	Infinite

Junction Temperature	+150°C
Storage Temperature Range	-65°C to +150°C
Soldering Information	
Infrared or Convection (30 sec)	260°C

Operating Ratings (Note 1)

Supply Voltage (Pin 3)	4.5V to 5.25V
Differential Voltage Between Any Two Grounds	<10 mV
Analog Input Voltage Range, AC Coupled	0V to V+
Temperature Range (Note 3)	-40°C to +85°C
Package Thermal Resistance (θ_{JA})	
32-Pin LLP	42°C/W

5V Electrical Characteristics (Note 4)

The following specifications apply for single supply with $V_+ = 5V$, Maximum Gain, $R_L = 100\Omega$, $V_{OUT} = 2 V_{PP}$, $f_{in} = 150$ MHz. Boldface limits apply at temperature extremes.

Symbol	Parameter	Conditions	Min (Note 6)	Typ (Note 5)	Max (Note 6)	Units
Dynamic Performance						
SSBW	Frequency Range			1200		MHz
	Maximum Voltage Gain	$f = 200$ MHz		22		dB
	Input Noise Voltage	Maximum Gain, $f > 1$ MHz, $R_{IN} = 0 \Omega$		1.1		nV/ \sqrt{Hz}
	Output Noise Voltage	Maximum Gain, $f > 1$ MHz		22		nV/ \sqrt{Hz}
	Noise Figure	Maximum Gain		5.5		dB
OIP3	Output Third Order Intercept Point	$f = 150$ MHz, $V_{OUT} = 4$ dBm per tone		43		dBm
	Output Third Order Intercept Point	$f = 200$ MHz, $V_{OUT} = 4$ dBm per tone		43		dBm
IMD3	Third Order Intermodulation Products	$f = 150$ MHz, $V_{OUT} = 4$ dBm per tone		-78		dBc
	Third Order Intermodulation Products	$f = 200$ MHz, $V_{OUT} = 4$ dBm per tone		-78		dBc
P1dB	1dB Compression Point	$f = 150$ MHz, $R_L = 100\Omega$		18.3		dBm
	1dB Compression Point	$f = 150$ MHz, $R_L = 200\Omega$		15.5		dBm
Analog I/O						
	Input Resistance	Differential	170	200	220	Ω
	Input Capacitance			2		pF
	Input Common Mode Voltage	Self Biased	2.42 2.24	2.55	2.71 2.79	V
	Input Common Mode Voltage Range	Externally Driven, CMRR > 40dB	1.5		3.5	V
	Maximum Input Voltage Swing	Volts peak to peak, differential		5.5		V
	Output Common Mode Voltage	Self Biased	2.4	2.55	2.7	V
	Maximum Differential Output Voltage Swing	Differential		5.9		V_{PP}
	Output Voltage Swing	Single ended (each output)	1.05	1V to 4V	4.00	V
V_{OS}	Output Offset Voltage	All Gain Settings	-25 -30	-2	25 30	mV
CMRR	Common Mode Rejection Ratio	Maximum Gain, $f=100$ MHz		60		dB
PSRR	Power Supply Rejection Ratio	Maximum Gain, $f=100$ MHz		60		dB
XTLK	Channel to Channel Crosstalk	Maximum Gain, $f=100$ MHz		-85		dBc
XTLK	Channel to Channel Crosstalk	Maximum Gain, $f=300$ MHz		-72		dBc

Symbol	Parameter	Conditions	Min (Note 6)	Typ (Note 5)	Max (Note 6)	Units
Gain Parameters						
	Maximum Gain	Gain Code 000000, DC Voltage Gain	21.7 21.65	21.85	22 22.05	dB
	Minimum Gain	Gain Code 111111, DC Voltage Gain	-9.25 -9.1	-9.5	-9.78 -9.8	dB
	Gain Adjust Range			31.5		dB
	Gain Step Size			0.5		dB
	Channel Matching	Gain Error between A and B channel.		±0.05		dB
	Channel Matching	Phase Shift between A and B channel.		±0.1		°
	Gain Step Error	Any two steps	-0.3	±0.05	0.3	dB
	Gain Step Error	Maximum Gain to Maximum Gain -12dB	-0.5	±0.1	0.5	dB
	Gain Step Phase Shift	between any two steps		0.5		°
	Gain Step Switching Time			15		ns
Power Requirements						
ICC	Supply Current	Each channel (two channels per package)		80	91	mA
P	Power	Each Channel		400		mW
ICC	Disabled Supply Current	Each Channel		7.5		mA
All Digital Inputs						
	Logic Compatibility	TTL, 2.5V CMOS, 3.3V CMOS				
VIL	Logic Input Low Voltage		0		0.4	V
VIH	Logic Input High Voltage		2.0		3.6	V
IIH	Logic Input High Input Current	Digital Input Voltage = 3.3V	-110		110	µA
IIL	Logic Input Low Input Current	Digital Input Voltage = 0V	-110		110	µA
Parallel and Pulse Mode Timing						
t _{GS}	Setup Time		3			ns
t _{GH}	Hold Time		3			ns
t _{LP}	Latch Low Pulse Width		7			ns
t _{PG}	Pulse Gap between Pulses		20			ns
t _{PW}	Minimum Latch Pulse Width		20			ns
t _{RW}	Reset Width		10			ns
Serial Mode Timing and AC Characteristics						
SPI™ Compatible						
f _{SCLK}	Serial Clock Frequency				10.5	MHz
t _{PH}	SCLK High State Duty Cycle	% of SCLK Period	40		60	%
t _{PL}	SCLK Low State Duty cycle	% of SCLK Period	40		60	%
t _{SU}	Serial Data In Setup Time			0.5		ns
t _H	Serial Data In Hold Time			5		ns
t _{ODZ}	Serial Data Out Driven-to- Tri-State Time	Referenced to Positive edge of CS		40	50	ns
t _{OZD}	Serial Data Out Tri-State-to-Driven Time	Referenced to Negative edge of SCLK		15	20	ns
t _{OD}	Serial Data Out Output Delay Time	Referenced to Negative edge of SCLK		15	20	ns
t _{CSS}	Serial Chip Select Setup Time	Referenced to Positive edge of SCLK	10	5		
t _{CSH}	Serial Chip Select Hold Time	Referenced to Positive edge of SCLK	10	5		
t _{IAG}	Inter-Access Gap	Minimum time Serial Chip Select pin must be asserted between accesses.		3		Cycles of SCLK
<p>Note 1: Absolute Maximum Ratings indicate limits beyond which damage to the device may occur. Operating Ratings indicate conditions for which the device is intended to be functional, but specific performance is not guaranteed. For guaranteed specifications, see the Electrical Characteristics tables.</p> <p>Note 2: Human Body Model, applicable std. MIL-STD-883, Method 3015.7. Machine Model, applicable std. JESD22-A115-A (ESD MM std. of JEDEC)</p>						

Field-Induced Charge-Device Model, applicable std. JESD22-C101-C (ESD FICDM std. of JEDEC).

Note 3: The maximum power dissipation is a function of $T_{J(MAX)}$, θ_{JA} . The maximum allowable power dissipation at any ambient temperature is $P_D = (T_{J(MAX)} - T_A) / \theta_{JA}$. All numbers apply for packages soldered directly onto a PC Board.

Note 4: Electrical Table values apply only for factory testing conditions at the temperature indicated. No guarantee of parametric performance is indicated in the electrical tables under conditions different than those tested

Note 5: Typical values represent the most likely parametric norm as determined at the time of characterization. Actual typical values may vary over time and will also depend on the application and configuration. The typical values are not tested and are not guaranteed on shipped production material.

Note 6: Limits are 100% production tested at 25°C. Limits over the operating temperature range are guaranteed through correlation using Statistical Quality Control (SQC) methods.

Note 7: Negative input current implies current flowing out of the device.

Note 8: Drift determined by dividing the change in parameter at temperature extremes by the total temperature change.

Connection Diagram

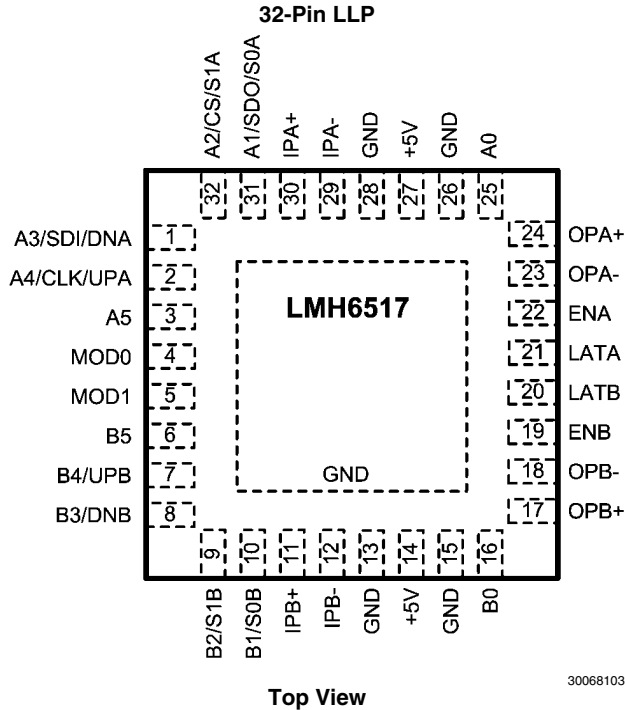

Ordering Information

Package	Part Number	Package Marking	Transport Media	NSC Drawing
32-Pin LLP	LMH6517SQ	L6517SQ	1k Units Tape and Reel	SQA32A
	LMH6517SQE		250 Units Tape and Reel	
	LMH6517SQX		4.5k Units Tape and Reel	

Pin Descriptions

Pin Number	Symbol	Description
Analog I/O		
30, 11	IPA+, IPB+	Amplifier non—inverting input. Internally biased to mid supply. Input voltage should not exceed V+ or go below GND by more than 0.5V.
29, 12	IPA-, IPB-	Amplifier inverting input. Internally biased to mid supply. Input voltage should not exceed V+ or go below GND by more than 0.5V.
24, 17	OPA+, OPB+	Amplifier non—inverting output. Internally biased to mid supply.
23, 18	OPA-, OPB-	Amplifier inverting output. Internally biased to mid supply.
Power		
13, 15, 26, 28, center pad	GND	Ground pins. Connect to low impedance ground plane. All pin voltages are specified with respect to the voltage on these pins. The exposed thermal pad is internally bonded to the ground pins.
14, 27	+5V	Power supply pins. Valid power supply range is 4.5V to 5.25V.
Common Control Pins		
4, 5	MOD0, MOD1	Digital Mode control pins. These pins float to the logic hi state if left unconnected. See below for Mode settings.
22, 19	ENA, ENB	Enable pins. Logic 1 = enabled state. See application section for operation in serial mode.
Digital Inputs Parallel Mode (MOD1 = 1, MOD0 = 1)		
25, 16	A0, B0	Gain bit zero = 0.5dB step. Gain steps down from maximum gain (000000 = Maximum Gain)
31, 10	A1, B1	Gain bit one = 1dB step
32, 9	A2, B2	Gain bit two = 2dB step
1, 8	A3, B3	Gain bit three = 4dB step
2, 7	A4, B4	Gain bit four = 8dB step
3, 6	A5, B5	Gain bit five = 16dB step
21, 20	LATA, LATB	Latch pins. Logic zero = active, logic 1 = latched. Gain will not change once latch is high. Connect to ground if the latch function is not desired.
Digital Inputs Serial Mode (MOD1 = 1, MOD0 = 0)		
2	CLK	Serial Clock
1	SDI	Serial Data In (SPI Compatible) See application section for more details.
32	CS	Serial Chip Select (SPI compatible)
31	SDO	Serial Data Out (SPI compatible)
3, 4, 6 — 10, 16, 20, 21, 25	GND	Pins unused in Serial Mode, connect to DC ground.
Digital Inputs Pulse Mode (MOD1 = 0, MOD0 = 1)		
2, 7	UPA, UPB	Up pulse pin. A logic 0 pulse will increase gain one step.
1, 8	DNA, DNB	Down pulse pin. A logic 0 pulse will decrease gain one step.
1 & 2 or 7 & 8		Pulsing both pins together will reset the gain to maximum gain.
31, 32	S0A, S1A	Step size zero and step size 1. (0,0) = 0.5dB; (0, 1)= 1dB; (1,0) = 2dB, and (1, 1)= 6dB
10, 9	S0B, S1B	Step size zero and step size 1. (0,0) = 0.5dB; (0, 1)= 1dB; (1,0) = 2dB, and (1, 1)= 6dB
3, 5, 6, 16, 25	GND	Pins unused in Pulse Mode, connect to DC ground.

Typical Performance Characteristics $V_{CC} = 5V$

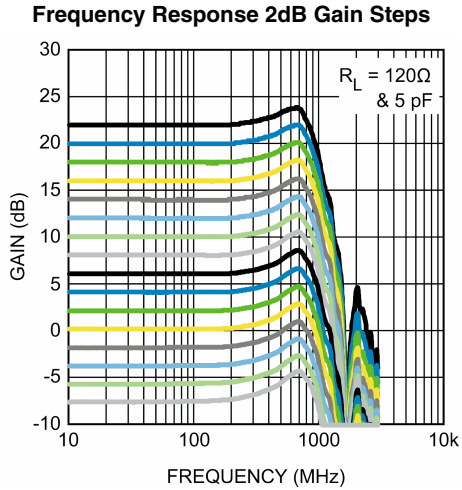

30068144

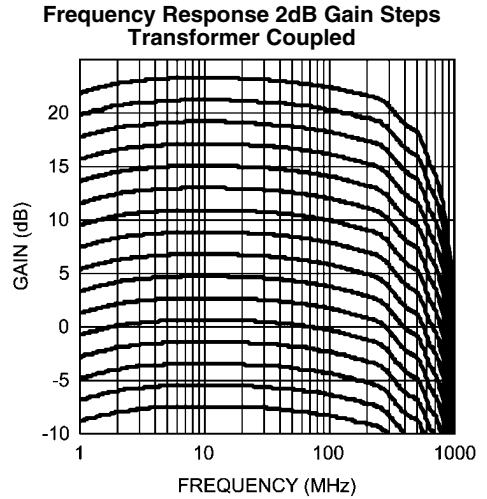

30068114

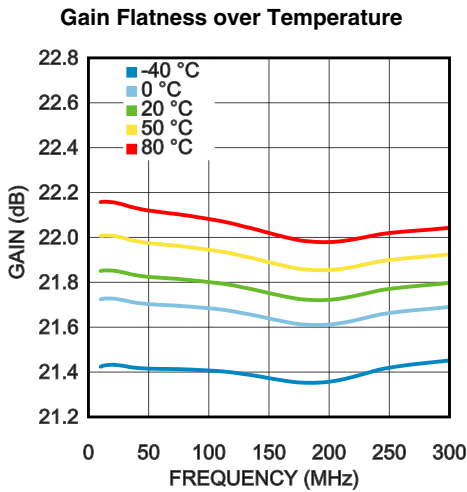

30068171

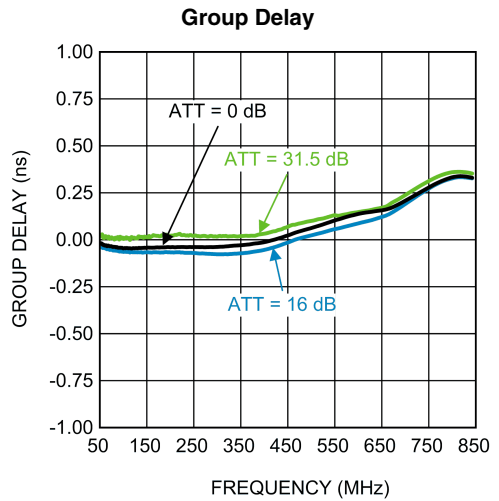

30068156

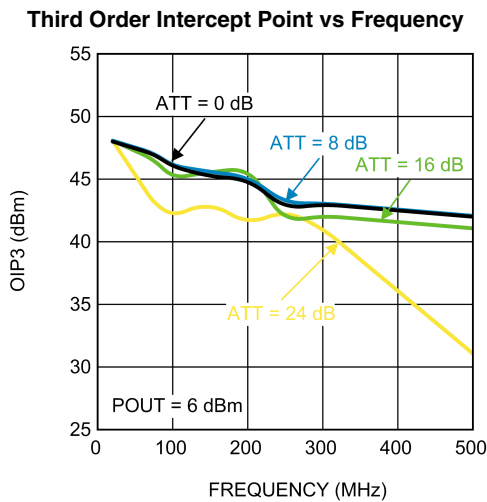

30068165

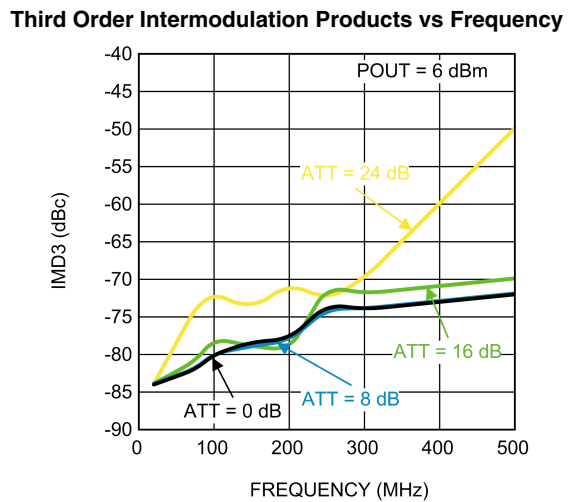

30068166

Third Order Intercept Point at Various Attenuator Settings
f = 150 MHz

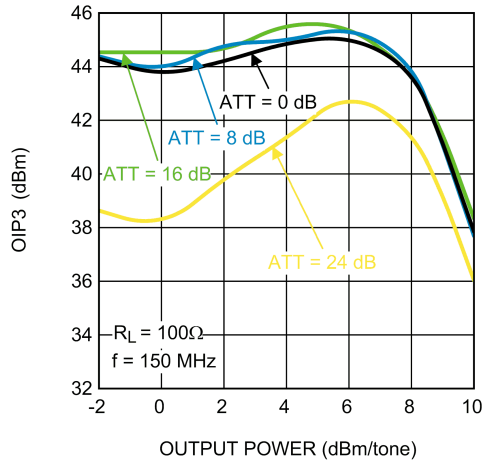

30068121

Third Order Intercept Point at Various Attenuator Settings
f = 200 MHz

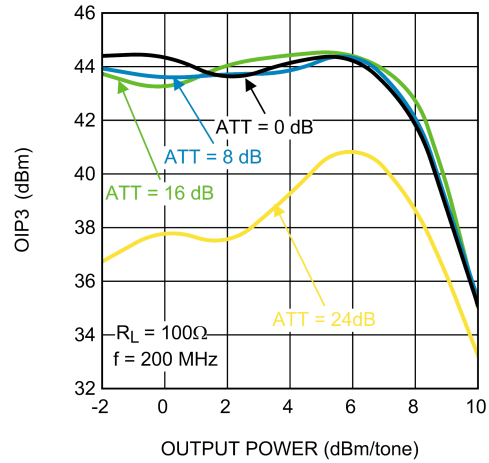

30068124

Third Order Intercept Point at Various Attenuator Settings
f = 250 MHz

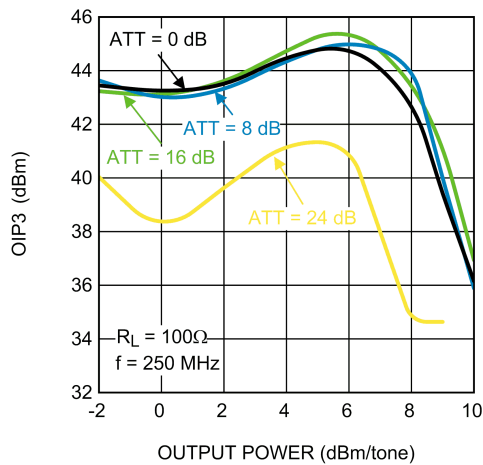

30068122

Third Order Intermodulation at Various Attenuator Settings
f = 200 MHz

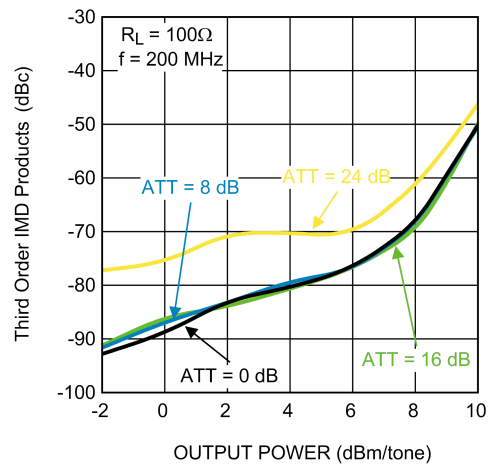

30068152

OIP3 vs Temperature

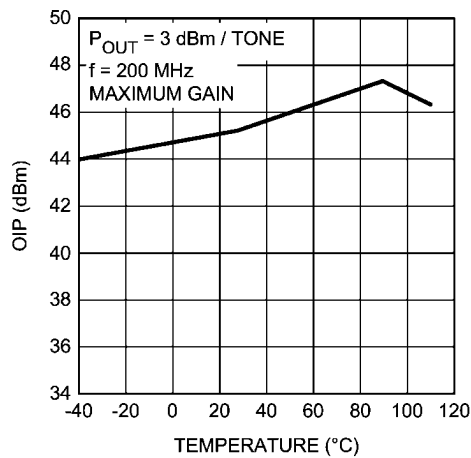

30068125

Gain Shift vs Temperature

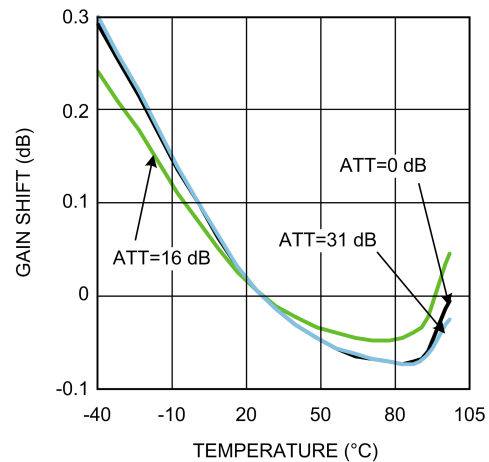

30068126

Cumulative Gain Error vs Attenuator Setting

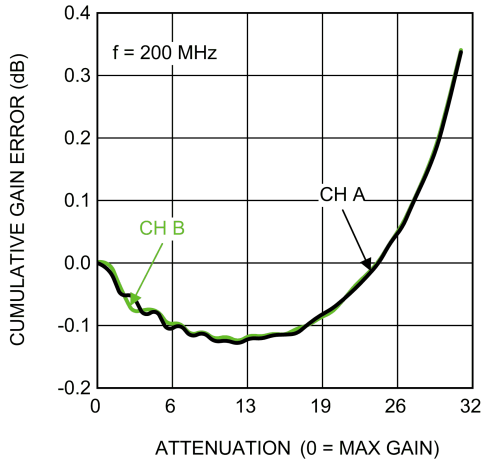

Cumulative Gain Error over Temperature

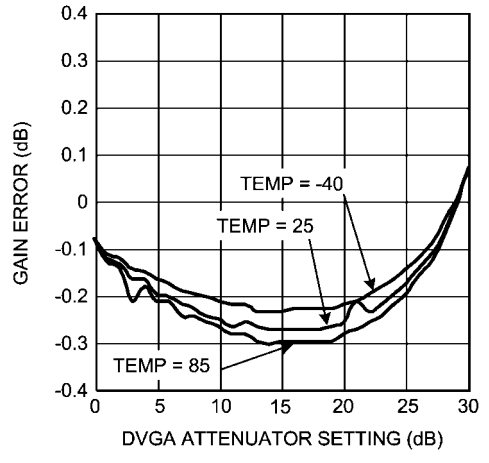

Phase Shift vs Attenuator Setting

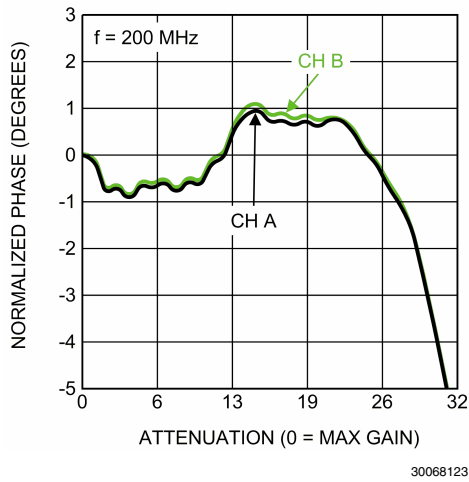

Noise Figure vs Attenuator Setting

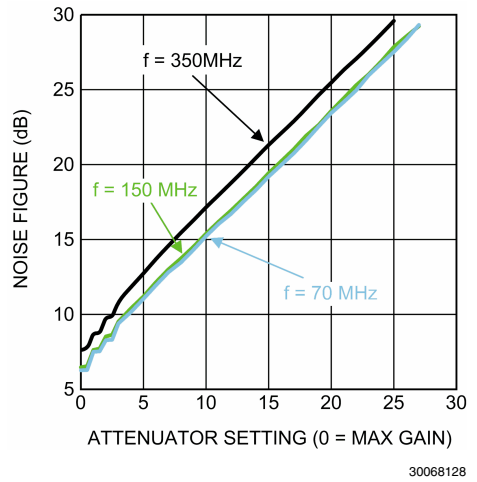

Noise Figure vs. Temperature

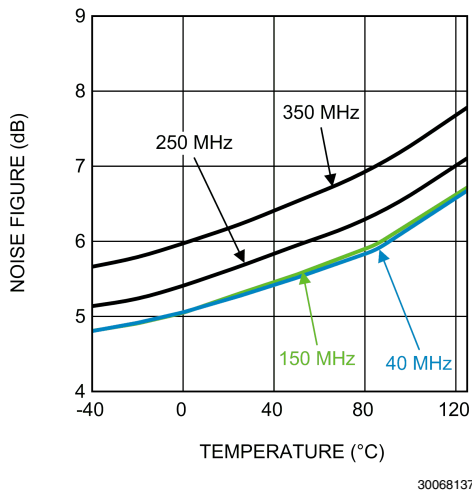

Noise Figure vs Frequency

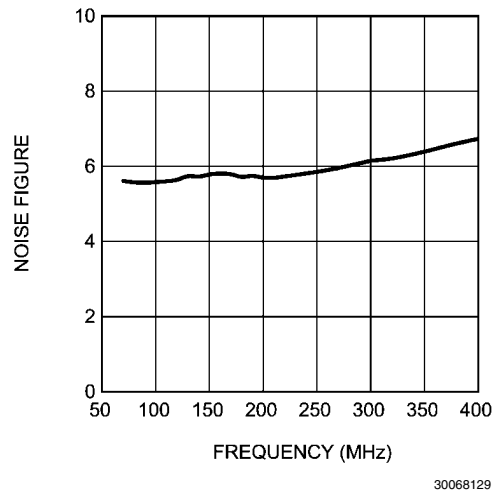

Second Order Harmonic Distortion at 10 MHz

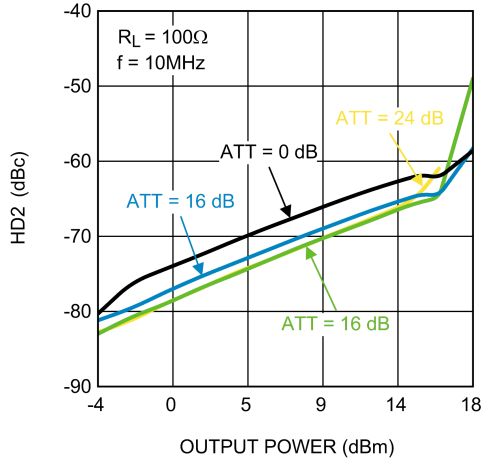

30068132

Third Order Harmonic Distortion at 10 MHz

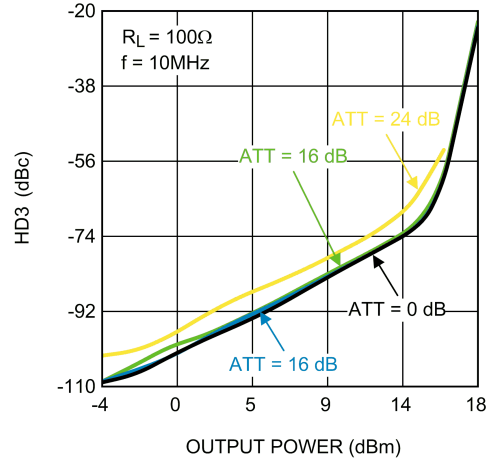

30068133

Second Order Harmonic Distortion at 75 MHz

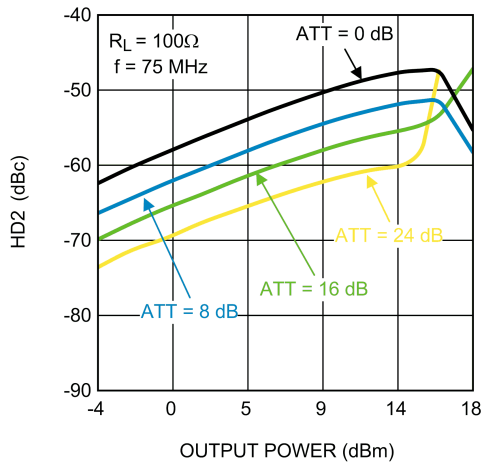

30068130

Third Order Harmonic Distortion at 75 MHz

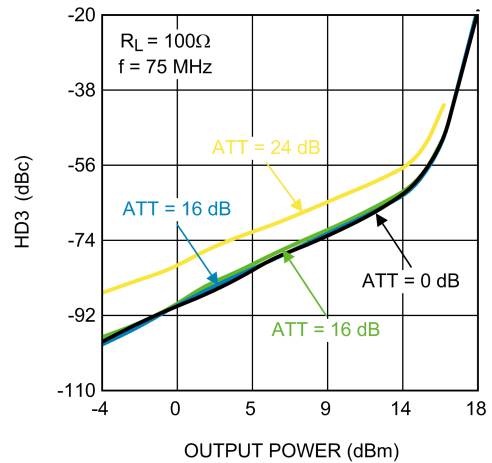

30068131

Second Order Harmonic Distortion at 150 MHz

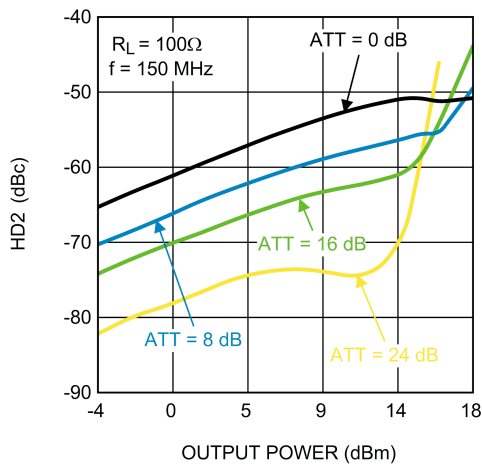

30068134

Third Order Harmonic Distortion at 150 MHz

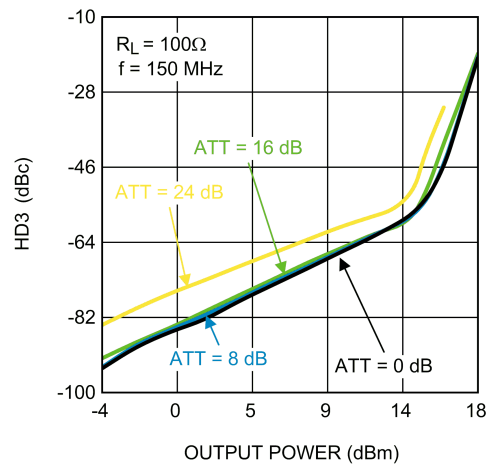

30068135

Second Order Harmonic Distortion at 200 MHz

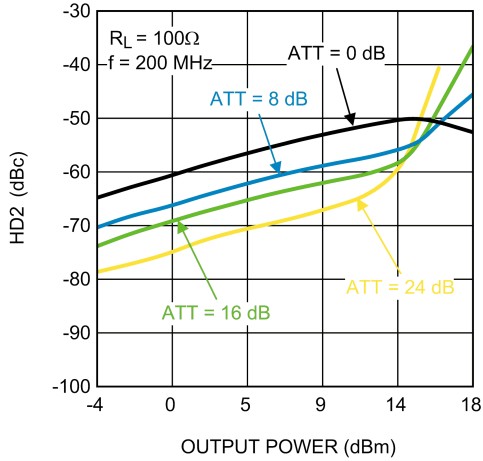

30068140

Third Order Harmonic Distortion at 200 MHz

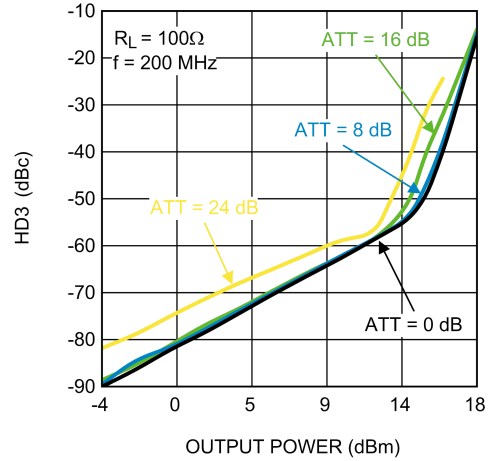

30068141

Second Order Harmonic Distortion at 250 MHz

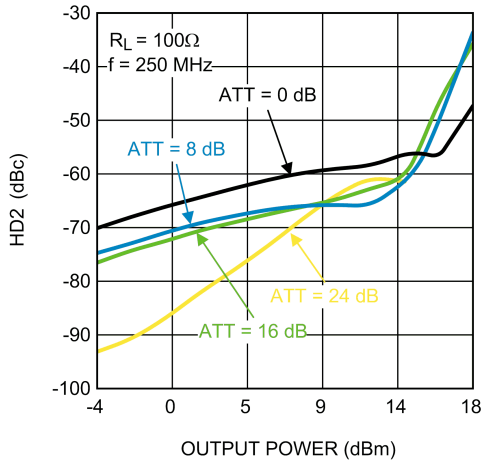

30068138

Third Order Harmonic Distortion at 250 MHz

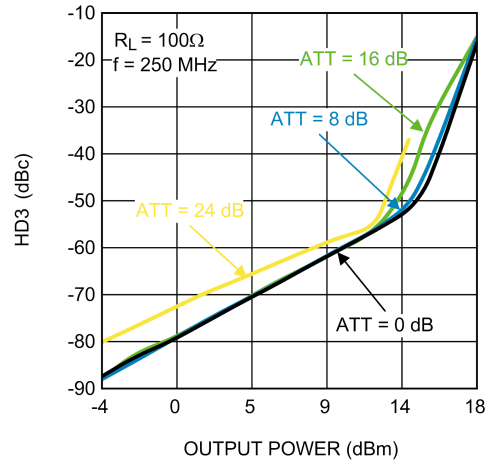

30068139

Max Gain vs. Temperature

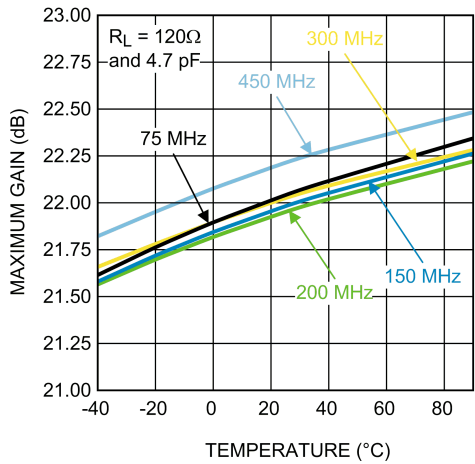

30068136

Supply Current vs. Temperature

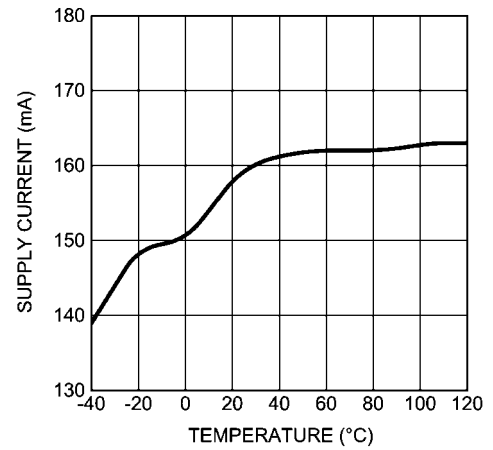

30068142

Output Offset Voltage vs. Temperature

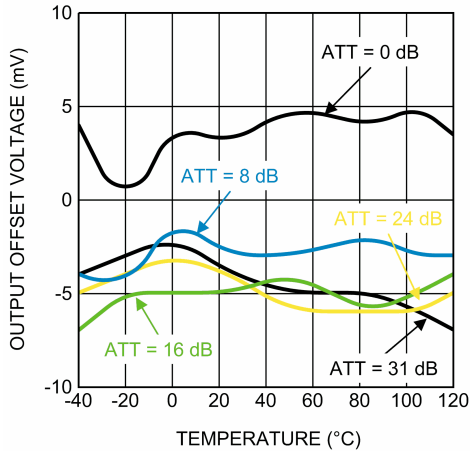

30068143

Pulse Response

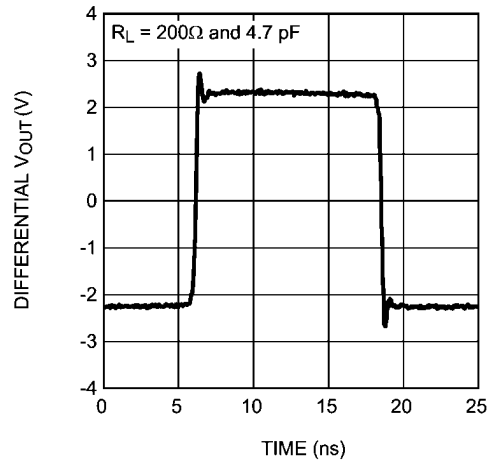

30068164

Gain Change Timing

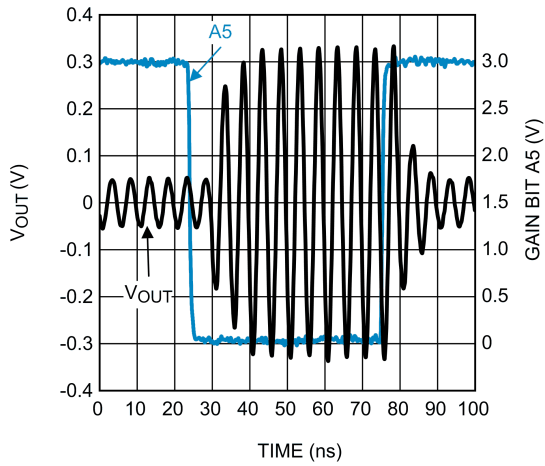

30068150

Enable Timing Maximum Gain

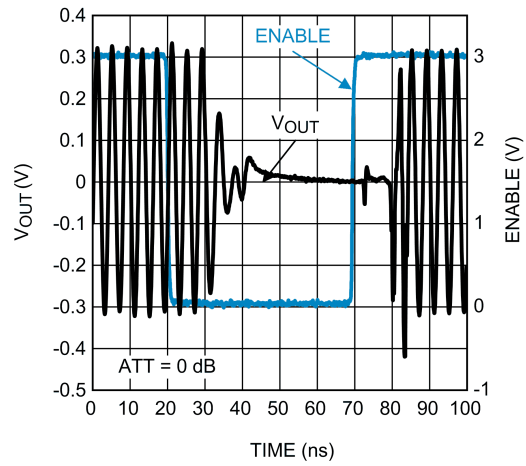

30068153

Enable Timing Minimum Gain

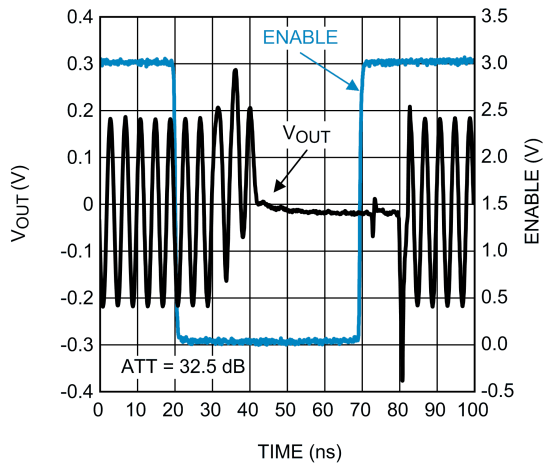

30068155

Channel To Channel Crosstalk

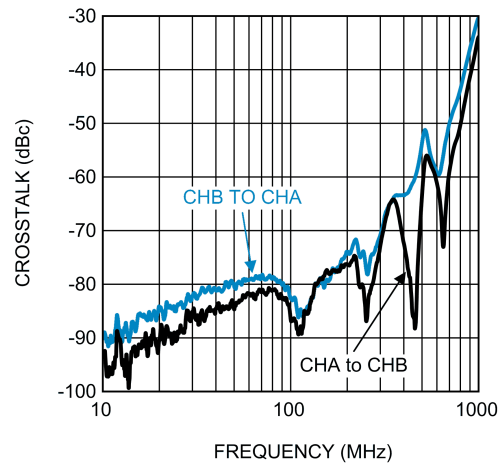

30068149

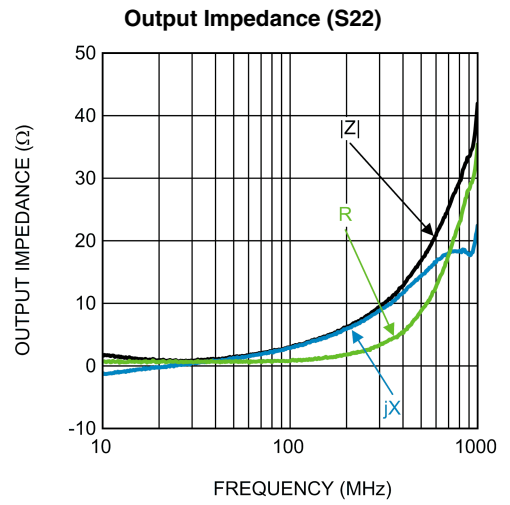
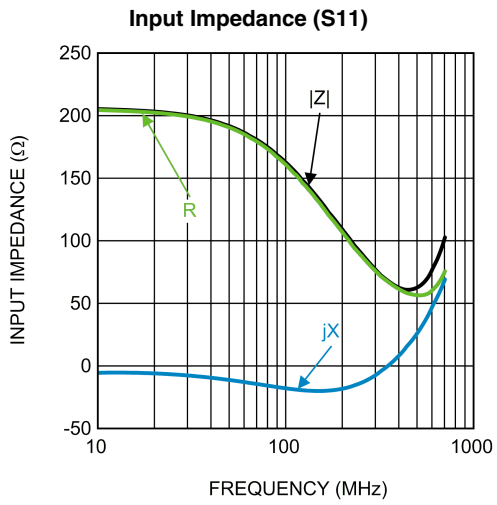

Application Information

The LMH6517 is a fully differential amplifier optimized for signal path applications up to 400 MHz. The LMH6517 has a 200Ω input and a low impedance output. The gain is digitally controlled over a 31.5 dB range from +22dB to -9.5dB. The LMH6517 is optimized for accurate gain steps and minimal

phase shift combined with low distortion products. This makes the LMH6517 ideal for voltage amplification and an ideal ADC driver where high linearity is necessary. The LMH6517 was designed for differential signal inputs only. Single ended inputs require a balun or transformer as shown on the evaluation board.

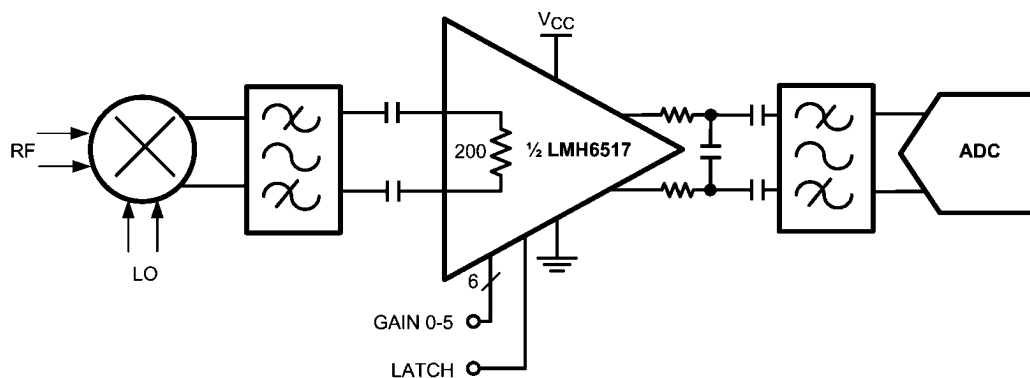

30068101

FIGURE 1. LMH6517 Typical Application

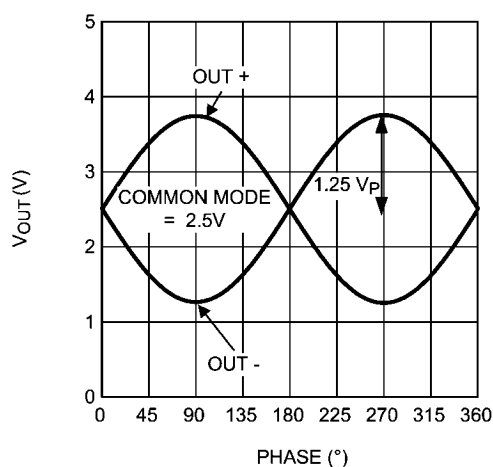

30068162

FIGURE 2. Output Voltage with Respect to the Output Common Mode

In order to help with system design National Semiconductor offers the SP16160CH1RB High IF Receiver reference design board. This board combines the LMH6517 DVGA with the ADC16DV160 ADC and provides a ready made solution for many IF receiver applications. The SP16160CH1RB delivers an IF chain receiver sensitivity of -105 dBm, with a 9 dB carrier-to-noise ratio in a 200 kHz channel, at 192 MHz input IF. With the digitally-controlled variable gain amplifier (DVGA) set at a maximum gain of 22 dB, the sensitivity is limited primarily by the noise contribution of the DVGA. In the presence of a strong blocker, with the DVGA gain set at 12 dB and blocker level kept at 1.6 dBm input to the ADC, the SP16160CH1RB board delivers sensitivity of -86 dBm. In this blocking condition, the receiver sensitivity is determined by the ADC's high spurious-free dynamic range (SFDR).

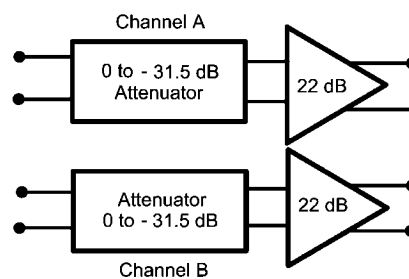

30068102

FIGURE 3. LMH6517 Block Diagram

INPUT CHARACTERISTICS

The LMH6517 input impedance is set by internal resistors to a nominal 200Ω . Process variations will result in a range of values as shown in the [5V Electrical Characteristics](#) table. At higher frequencies parasitic reactances will start to impact the impedance. This characteristic will also depend on board layout and should be verified on the customer's system board.

At maximum gain the digital attenuator is set to 0 dB and the input signal will be much smaller than the output. At minimum gain the output is 9 dB or more smaller than the input. In this configuration the input signal will begin to clip against the ESD protection diodes before the output reaches maximum swing limits. The input signal cannot swing more than 0.5V below the negative supply voltage (normally 0V) nor should it exceed the positive supply voltage. The input signal will clip and cause severe distortion if it is too large. Because the input stage self biases to approximately mid rail the supply voltage will impose the limit for input voltage swing.

At the frequencies where the LMH6517 is the most useful the input impedance is not exactly 200Ω and it may not be purely resistive. For many AC coupled applications the impedance can be easily changed using LC circuits to transform the actual impedance to the desired impedance.

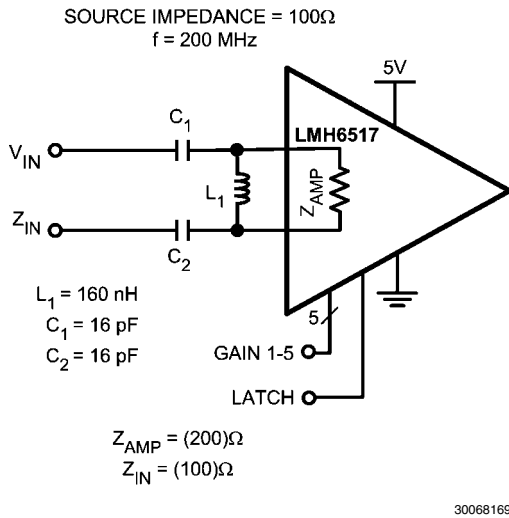

FIGURE 4. Differential 200Ω LC Conversion Circuit

In *Figure 4* a circuit is shown that matches the amplifier 200Ω input with source is 100Ω. This would be the case when connecting the LMH6517 directly to many common types of 50Ω test equipment. For an easy way to calculate the L and C circuit values there are several options for online tools or down-loadable programs. The following tool might be helpful. <http://www.circuitsage.com/matching/matcher2.html>

Excel can also be used for simple circuits; however, the “Analysis ToolPak” add-in must be installed to calculate complex numbers.

OUTPUT CHARACTERISTICS

The LMH6517 has a low impedance output very similar to a traditional Op-amp output. This means that nearly any load can be driven with minimal gain loss. Matching load impedance for proper termination of filters is as easy as inserting the proper value of resistor between the filter and the amplifier. This flexibility makes system design and gain calculations very easy. The LMH6517 was designed to run from a single 5V supply. In spite of this low supply voltage the LMH6517 is still able to deliver very high power gains when driving low impedance loads.

The ability of the LMH6517 to drive low loads creates an opportunity to greatly increase power gain, if required. One example of using power gain to offset filter loss is shown in *Figure 5*. A graph showing power gain over various load conditions is shown below in *Figure 5*. This graph clearly shows the reduction in power gain caused by back termination. While many RF amplifiers have internal resistance and deliver maximum power into a matched load the LMH6517 has an output resistance very near to zero Ohms. The graph shows that maximum power transfer does indeed occur with

a load of nearly zero Ohms. Another useful feature of the graph is the ability to determine how much gain can be recovered by dropping load resistance when it is necessary to back terminate either a transmission line or a filter.

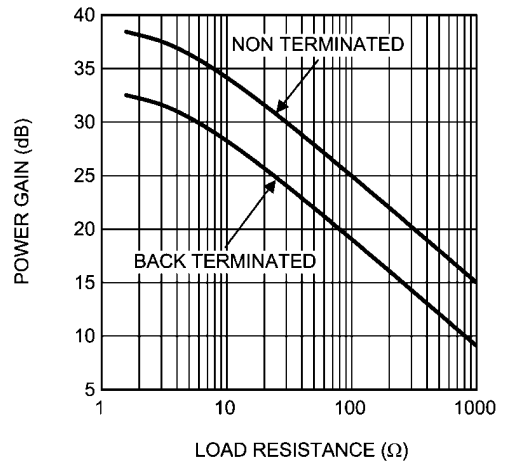

FIGURE 5. Power Gain vs Load
 Note 6dB power loss when adding load matching resistors.

Here is an example of how to use the chart in *Figure 5*. In a system it is desired to have at least 20dB of maximum gain from the amplifier input to output. The system noise and harmonic distortion requirements dictate a 200 Ohm filter between the amplifier and the ADC. Using the chart we can see that a back terminated 200 Ohm filter will result in a net 16 dB of gain at the filter input. To recover this loss it is possible to use a 1:4 balun to drop the load condition of the filter to 50 Ohms at the amplifier output. This gives an additional 6dB of power gain. Since the transformer has a power loss of approximately 1dB we end up with 21dB of gain at the filter output instead of 16dB. See *Figure 20* for an example where the filter performs the impedance transformation function.

The LMH6517, like most high frequency amplifiers, is sensitive to loading conditions on the output. Load conditions that include small amounts of capacitance connected directly to the output can cause stability problems. In order to ensure output stability resistors should be connected directly at the amplifier output followed by a small capacitor. This circuit sets a dominant pole that will cancel out board parasitics in most applications. An example of this is shown in figure *Figure 6*. In this example the amplifier and ADC are less than 0.1 wavelength apart and do not require a terminated transmission line. A more sophisticated filter may require better impedance matching. Some example filters are shown later.

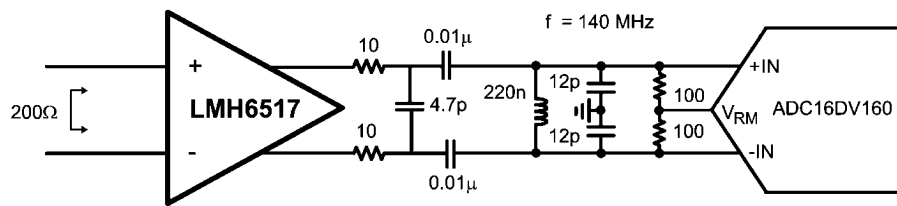

FIGURE 6. Output Configuration

DIGITAL CONTROL

The LMH6517 will support three modes of control, parallel mode, serial mode (SPI compatible) and pulse mode. Parallel mode is fastest and requires the most board space for logic line routing. Serial mode is compatible with existing SPI compatible systems. The pulse mode is both fast and compact, but must step through intermediate gain steps when making large gain changes.

The LMH6517 has gain settings covering a range of 31.5 dB. To avoid undesirable signal transients the LMH6517 should not be powered on with large inputs signals present. Careful planning of system power on sequencing is especially important to avoid damage to ADC inputs.

The LMH6517 was designed to interface with 3.3V CMOS logic circuits. If operation with 5V logic is required a simple voltage divider at each logic pin will allow for this. To properly terminate 100Ω transmission lines a divider with a 66.5Ω resistor to ground and a 33.2Ω series resistor will properly terminate the line as well as give the 3.3V logic levels. Care should be taken not to exceed the 3.6V absolute maximum voltage rating of the logic pins.

Some pins on the LMH6517 have different functions depending on the digital control mode. These functions will be described in the sections to follow.

Control Mode	MOD1 Pin Value	MOD0 Pin Value
Parallel	1	1
Serial	1	0
Pulse	0	1
Reserved	0	0

PARALLEL MODE (MOD1= 1, MOD0 = 1)

Parallel mode offers the fastest gain update capability with the drawback of requiring the most board space dedicated to control lines. When designing a system that requires very fast gain changes parallel mode is the best selection.

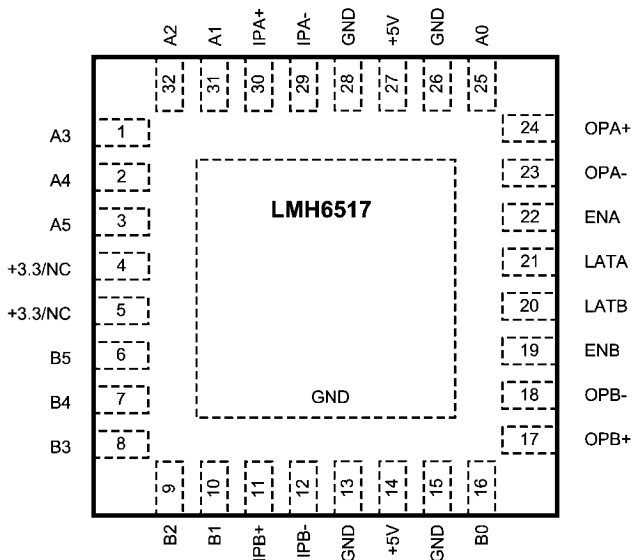

FIGURE 7. Pin Functions for Parallel Mode

The LMH6517 has a 6-bit gain control bus as well as a Latch pin. When the Latch pin is low, data from the gain control pins is immediately sent to the gain circuit (i.e. gain is changed

immediately). When the Latch pin transitions high the current gain state is held and subsequent changes to the gain set pins are ignored. To minimize gain change glitches multiple gain control pins should not change while the latch pin is low. In order to achieve the very fast gain step switching time of 5 ns the internal gain change circuit is very fast. Gain glitches could result from timing skew between the gain set bits. This is especially the case when a small gain change requires a change in state of three or more gain control pins. If continuous gain control is desired the Latch pin can be tied to ground. This state is called transparent mode and the gain pins are always active. In this state the timing of the gain pin logic transitions should be planned carefully to avoid undesirable transients

ENA and ENB pins are provided to reduce power consumption by disabling the highest power portions of the LMH6517. The gain register will preserve the last active gain setting during the disabled state. These pins will float high and can be left disconnected if they won't be used. If the pins are left disconnected a 0.01uF capacitor to ground will help prevent external noise from coupling into these pins. See the Typical Performance section for disable and enable timing information.

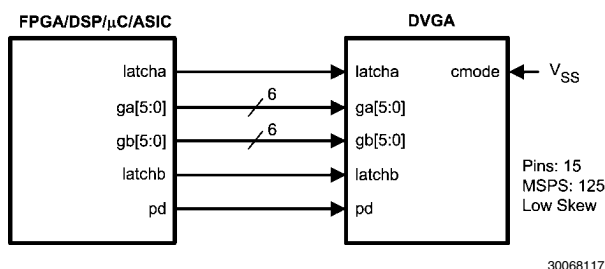

FIGURE 8. Parallel Mode Connection for Fastest Response

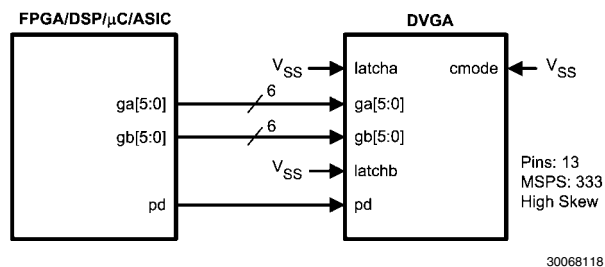

FIGURE 9. Parallel Mode Connection Not Using Latch Pins (Latch pins tied to logic low state)

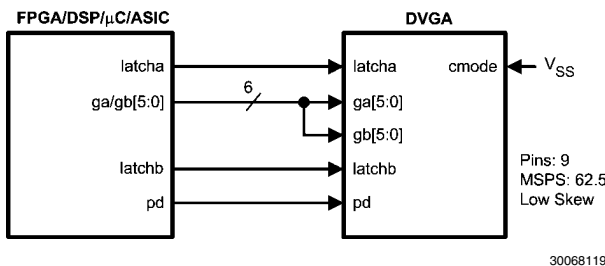

FIGURE 10. Parallel Mode Connection Using Latch Pins to Mux Digital Data

SPI COMPATIBLE SERIAL INTERFACE (MOD1= 1, MOD0 = 0)

Serial interface allows a great deal of flexibility in gain programming and reduced board complexity. Using only 4 wires for both channels allows for significant board space savings. The trade off for this reduced board complexity is slower response time in gain state changes. For systems where gain is changed only infrequently or where only slow gain changes are required serial mode is the best choice.

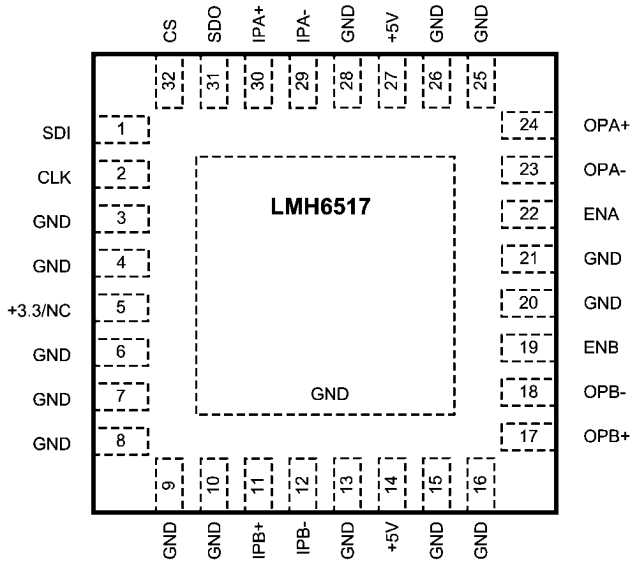

FIGURE 11. Pin Functions for Serial Mode

The LMH6517 has a serial interface that allows access to the control registers. The serial interface is a generic 4-wire synchronous interface that is compatible with SPI type interfaces that are used on many microcontrollers and DSP controllers. The serial mode is active when the two mode pins are set as follows: MOD1=1, MOD0=0). In this configuration the pins function as shown in the pin description table. The SPI interface uses the following signals: clock input (CLK), serial data in (SDI), serial data out, and serial chip select (CS)

ENA and ENB pins are active in the serial mode. For fast disable capability these pins can be used and the serial register will hold the last active gain state. These pins will float high and can be left disconnected for serial mode. The serial control bus can also disable the DVGA channels, but at a much slower speed. The serial enable function is an AND function. For a channel to be active both the Enable pin and the serial control register must be in the enabled state. To disable a channel either method will suffice. See the Typical Performance section for disable and enable timing information.

LATA and LATB pins are not active during serial mode.

CLK : This pin is the serial clock pin. It is used to register the input data that is presented on the SDI pin on the rising edge; and to source the output data on the SDO pin on the falling edge. User may disable clock and hold it in the low state, as long as the clock pulse-width minimum specification is not violated when the clock is enabled or disabled.

CS: This pin is the chip select pin. Each assertion starts a new register access - i.e., the SDATA field protocol is required. The user is required to deassert this signal after the 16th clock. If the SCSb is deasserted before the 16th clock, no address or data write will occur. The rising edge captures the address just shifted-in and, in the case of a write operation, writes the addressed register. There is a minimum pulse-width requirement for the deasserted pulse - which is specified in the Electrical Specifications section.

SDI: This pin is an input for the serial data. It must observe setup/hold requirements with respect to the SCLK. Each cycle is 16-bits long

SDO: This is the data output pin. This SDO pin is an open drain output and requires an external bias resistor. See Figure 12 for resistor sizing guidance. This output is normally at TRI-STATE and is driven only when SCSb is asserted. Upon SCSb assertion, contents of the register addressed during the first byte are shifted out with the second 8 SCLK falling edges. Upon power-up, the default register address is 00h.

Each serial interface access cycle is exactly 16 bits long as shown in Figure 13. Each signal's function is described below. The read timing is shown in Figure 14, while the write timing is shown in figure Figure 15.

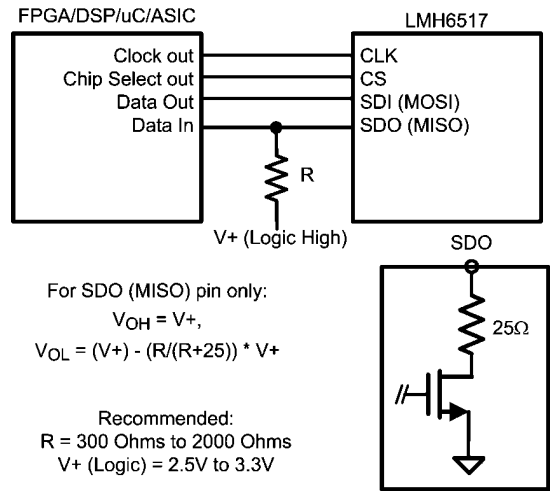
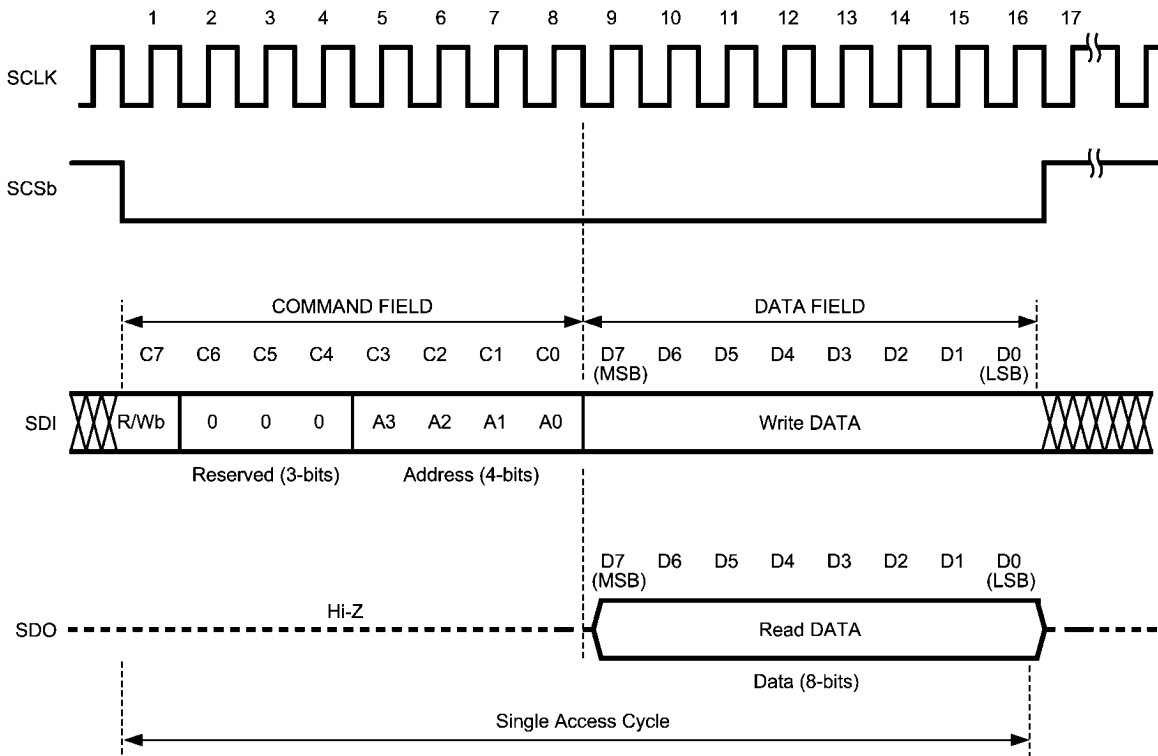

FIGURE 12. SDO Pin External Bias Resistor Configuration



30068112

FIGURE 13. Serial Interface Protocol (SPI compatible)

R/Wb	Read / Write bit. A value of 1 indicates a read operation, while a value of 0 indicates a write operation.
Reserved	Not used. Must be set to 0.
ADDR:	Address of register to be read or written.
DATA	In a write operation the value of this field will be written to the addressed register when the chip select pin is deasserted. In a read operation this field is ignored.

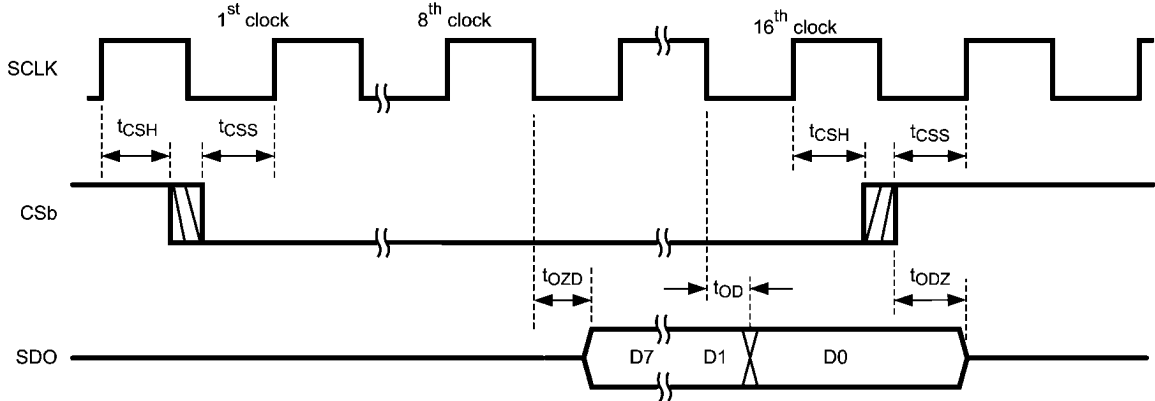

30068111

FIGURE 14. Read Timing

**Read Timing
Data Output on SDO Pin**

Parameter	Description
t_{CSH}	Chip select hold time
t_{CSS}	Chip select setup time
t_{OZD}	Initial output data delay
t_{ODZ}	High impedance delay
t_{OD}	Output data delay

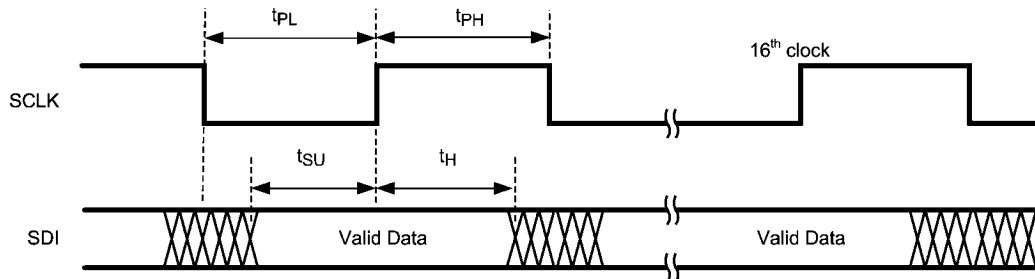

30068110

FIGURE 15. Write Timing
Data Written to SDI Pin

**Write Timing
Data Input on SDI Pin**

Parameter	Description
t_{PL}	Minimum clock low time (clock duty cycle)
t_{PH}	Minimum clock high time (clock duty cycle)
t_{SU}	Input data setup time
t_{H}	Input data hold time

Serial Word Format for LMH6517

C7	C6	C5	C4	C3	C2	C1	C0
1=read	0	0	0	0	0	0	0=Ch A
0=write							1=Ch B

**Serial Word Format for LMH6517
(cont)**

Enable	Gb5	Gb4	Gb3	Gb2	Gb1	Gb0	RES
1=On	1=	1=	1=	1=	1=	1=	0
0=Off	+16dB	+8dB	+4dB	+2dB	+1dB	+0.5dB	

PULSE MODE (MOD1= 0, MOD0 = 1)

Pulse mode is a simple yet fast way to adjust gain settings. Using only two control lines per device the LMH6517 gain can be changed by simple up and down signals. Gain steps are selectable either by hard wiring the board or using two additional logic inputs. For a system where gain changes can be stepped from one gain to the next and where board space is limited this mode may be the best choice. The ENA and ENB pins are fully active during pulse mode, and the channel gain state is preserved during the disabled state. See the Typical

Performance section for disable and enable timing information.

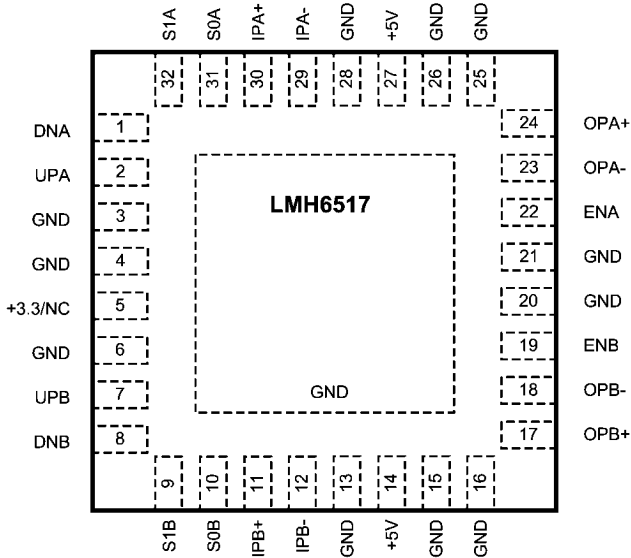

30068108

FIGURE 16. Pin Functions for Pulse Mode

The LMH6517 supports a simple pulse up or pulse down control mode. In this mode the gain step size can be selected from a choice of 0.5, 1, 2 or 6dB steps. In operation the gain can be quickly adjusted either up or down one step at a time by a negative pulse on the UP or DN pins. This mode of operation is most suitable for applications where board space is at a premium and high speed gain changes are desired. As shown in Figure 17 each gain step pulse must have a logic high state of at least $t_{PW} = 20$ ns and a logic low state of at least $t_{PG} = 20$ ns for the pulse to register as a gain change signal.

To provide a known gain state there is a reset feature in pulse mode. To reset the gain to maximum gain both the UP and DN pins must be strobed low together as shown in Figure 17. There must be an overlap of at least $t_{RW} = 20$ ns for the reset to register.

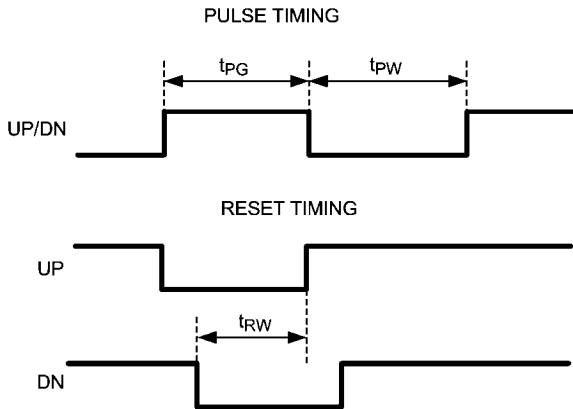

30068109

FIGURE 17. Pulse Mode Timing

EXPOSED PAD LLP PACKAGE

The LMH6517 is packaged in a thermally enhanced package. The exposed pad is connected to the GND pins. It is recommended, but not necessary, that the exposed pad be connected to the supply ground plane. In any case, the thermal dissipation of the device is largely dependent on the attachment of this pad. The exposed pad should be attached to as much copper on the circuit board as possible, preferably external copper. However, it is also very important to maintain good high speed layout practices when designing a system board. Please refer to the LMH6517 evaluation board for suggested layout techniques.

Package information is available on the National web site. <http://www.national.com/packaging/folders/sqa16a.html>

INTERFACING TO ADC

The LMH6517 was designed to be used with high speed ADCs such as the ADC16DV160. As shown in the Typical Application on page 1, AC coupling provides the best flexibility especially for IF sub-sampling applications. For DC coupled applications the use of a level shifting amplifier or a resistive biasing network may be possible.

The inputs of the LMH6517 will self bias to the optimum voltage for normal operation. The internal bias voltage for the inputs is approximately mid rail which is 2.5V with the typical 5V power supply condition. In most applications the LMH6517 input will need to be AC coupled.

The output common mode voltage is also self biasing to mid supply. This means that for driving most ADCs AC coupling is required. Since most often a band pass filter is desired between the amplifier and ADC the bandpass filter can be configured to block the DC voltage of the amplifier output from the ADC input.

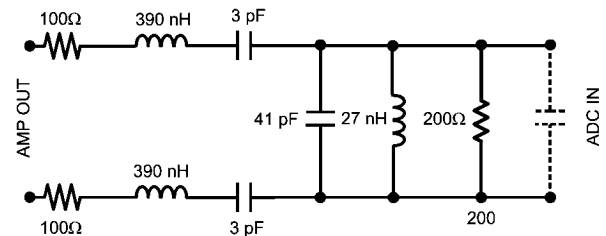

30068106

FIGURE 18. Bandpass Filter Center Frequency is 140 MHz with a 20 MHz Bandwidth Designed for 200Ω Impedance

ADC Noise Filter

Below are filter schematics and a table of values for some common IF frequencies. The filter shown in Figure 19 offers a good compromise between bandwidth, noise rejection and cost. This filter topology is the same as is used on the AD-C14V155KDRB High IF Receiver reference design board. This filter topology works best with the 12 and 14 bit sub-sampling analog to digital converters shown in the *Compatible High Speed Analog To Digital Converters* table.

Filter Component Values

Filter Component Values					
	Fc	75 MHz	140 MHz	170 MHz	250 MHz
	BW	40 MHz	20 MHz	25 MHz	Narrow Band
Components	R1, R2	100Ω	200Ω	100Ω	499Ω
	L1, L2	390 nH	390 nH	560 nH	—
	C1, C2	10 pF	3 pF	1.4 pF	47 pF
	C3	22 pF	41 pF	32 pF	11 pF
	L5	220 nH	27 nH	30 nH	22 nH
	R3, R4	100Ω	200Ω	100Ω	499Ω

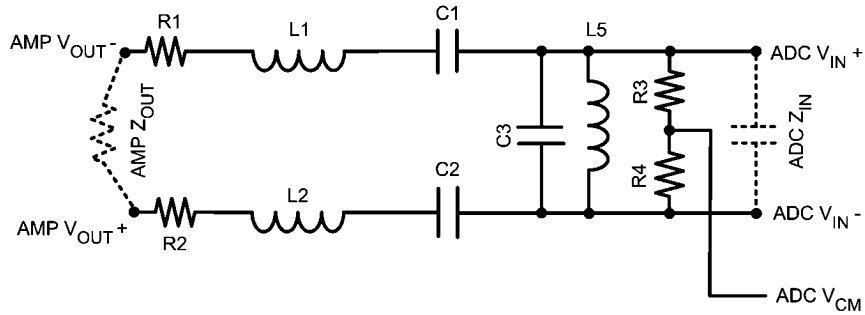

30068113

FIGURE 19. Sample Filter

While the filters shown above have excellent performance in most respects they have one very large drawback, and that is voltage loss. There is a 6dB loss right up front from the matching resistors (R1 and R2 in [Figure 19](#)) and there are additional losses in the filter, primarily due to the resistive losses of the inductors. One solution is to use larger inductors with higher Q ratings. An even better solution is to use the filter as an impedance transforming circuit. Designing a filter with a low impedance input and a high impedance output will result in a voltage gain that can be used to offset the voltage losses. While this solution won't work with high impedance amplifiers, the LMH6517's low impedance output stage is

perfectly suited for it. In essence the additional power gained from driving a given voltage into a lower value load impedance is used to offset the power lost in the filter and matching resistors.

The filter shown in [Figure 20](#) uses both an impedance transform as well as a slight input impedance mismatch to reduce the voltage loss from the amplifier to the ADC input. This configuration makes use of the strengths of the LMH6517 output stage to deliver the best linearity possible. Due to the low impedance output stage the LMH6517 can drive a lot of current into a low impedance load and still deliver high linearity signals.

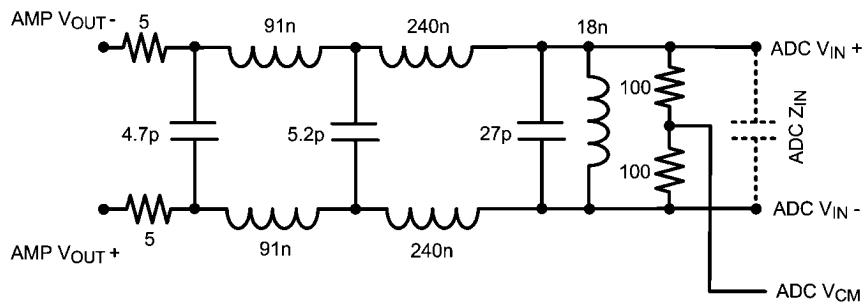

30068170

FIGURE 20. Impedance Transforming Filter
25 Ω Input 200 Ω Output, 210 MHz Center Frequency

POWER SUPPLIES

The LMH6517 was designed primarily to be operated on 5V power supplies. The voltage range for V_{CC} is 4.5V to 5.25V. A 5V supply provides the best performance while lower supplies will result in less power consumption. Power supply regulation of 2.5% or better is advised. When operated on a board with high speed digital signals it is important to provide

isolation between digital signal noise and the LMH6517 inputs. The SP16160CH1RB reference board provides an example of good board layout.

Of special note is that the digital circuits are powered from an internal supply voltage of 3.3V. The logic pins should not be driven above the absolute maximum value of 3.6V. See the Digital Control section for details.

Compatible High Speed Analog To Digital Converters

Product Number	Max Sampling Rate (MSPS)	Resolution	Channels
ADC12L063	62	12	SINGLE
ADC12DL065	65	12	DUAL
ADC12L066	66	12	SINGLE
ADC12DL066	66	12	DUAL
CLC5957	70	12	SINGLE
ADC12L080	80	12	SINGLE
ADC12DL080	80	12	DUAL
ADC12C080	80	12	SINGLE
ADC12C105	105	12	SINGLE
ADC12C170	170	12	SINGLE
ADC12V170	170	12	SINGLE
ADC14C080	80	14	SINGLE
ADC14C105	105	14	SINGLE
ADC14DS105	105	14	DUAL
ADC14155	155	14	SINGLE
ADC14V155	155	14	SINGLE
ADC16V130	130	16	SINGLE
ADC16DV160	160	16	DUAL
ADC08D500	500	8	DUAL
ADC08500	500	8	SINGLE
ADC08D1000	1000	8	DUAL
ADC081000	1000	8	SINGLE
ADC08D1500	1500	8	DUAL
ADC081500	1500	8	SINGLE
ADC08(B)3000	3000	8	SINGLE
ADC08L060	60	8	SINGLE
ADC08060	60	8	SINGLE
ADC10DL065	65	10	DUAL
ADC10065	65	10	SINGLE
ADC10080	80	10	SINGLE
ADC08100	100	8	SINGLE
ADCS9888	170	8	SINGLE
ADC08(B)200	200	8	SINGLE
ADC11C125	125	11	SINGLE
ADC11C170	170	11	SINGLE

Physical Dimensions inches (millimeters) unless otherwise noted

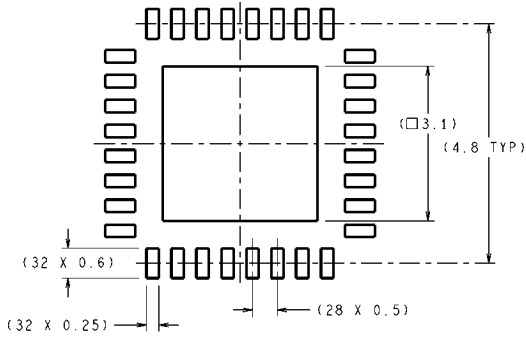

DIMENSIONS ARE IN MILLIMETERS
DIMENSIONS IN () FOR REFERENCE ONLY

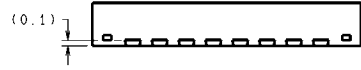

RECOMMENDED LAND PATTERN

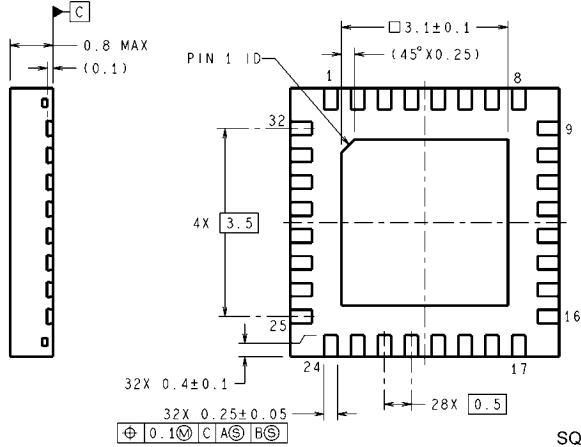
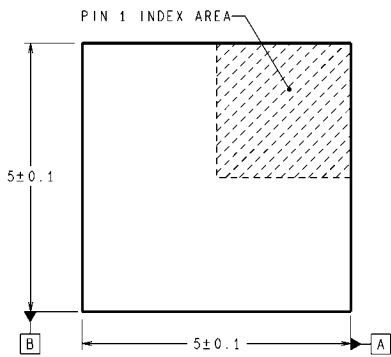

32-Pin Package
NS Package Number SQA32A

SQA32A (Rev B)

Notes

Notes

TI/NATIONAL INTERIM IMPORTANT NOTICE

Texas Instruments has purchased National Semiconductor. As of Monday, September 26th, and until further notice, products sold or advertised under the National Semiconductor name or logo, and information, support and interactions concerning such products, remain subject to the preexisting National Semiconductor standard terms and conditions of sale, terms of use of website, and Notices (and/or terms previously agreed in writing with National Semiconductor, where applicable) and are not subject to any differing terms and notices applicable to other TI components, sales or websites. To the extent information on official TI and National websites and business social networking media, etc., pertains to both TI and National-branded products, both companies' instructions, warnings and limitations in the above-referenced terms of use apply.

Following are URLs where you can obtain information on other Texas Instruments products and application solutions:

Products		Applications	
Audio	www.ti.com/audio	Communications and Telecom	www.ti.com/communications
Amplifiers	amplifier.ti.com	Computers and Peripherals	www.ti.com/computers
Data Converters	dataconverter.ti.com	Consumer Electronics	www.ti.com/consumer-apps
DLP® Products	www.dlp.com	Energy and Lighting	www.ti.com/energy
DSP	dsp.ti.com	Industrial	www.ti.com/industrial
Clocks and Timers	www.ti.com/clocks	Medical	www.ti.com/medical
Interface	interface.ti.com	Security	www.ti.com/security
Logic	logic.ti.com	Space, Avionics and Defense	www.ti.com/space-avionics-defense
Power Mgmt	power.ti.com	Transportation and Automotive	www.ti.com/automotive
Microcontrollers	microcontroller.ti.com	Video and Imaging	www.ti.com/video
RFID	www.ti-rfid.com	Wireless	www.ti.com/wireless-apps
RF/IF and ZigBee® Solutions	www.ti.com/lprf	TI E2E Community Home Page	e2e.ti.com

Mailing Address: Texas Instruments, Post Office Box 655303, Dallas, Texas 75265

Copyright© 2011 Texas Instruments Incorporated

IMPORTANT NOTICE

Texas Instruments Incorporated and its subsidiaries (TI) reserve the right to make corrections, modifications, enhancements, improvements, and other changes to its products and services at any time and to discontinue any product or service without notice. Customers should obtain the latest relevant information before placing orders and should verify that such information is current and complete. All products are sold subject to TI's terms and conditions of sale supplied at the time of order acknowledgment.

TI warrants performance of its hardware products to the specifications applicable at the time of sale in accordance with TI's standard warranty. Testing and other quality control techniques are used to the extent TI deems necessary to support this warranty. Except where mandated by government requirements, testing of all parameters of each product is not necessarily performed.

TI assumes no liability for applications assistance or customer product design. Customers are responsible for their products and applications using TI components. To minimize the risks associated with customer products and applications, customers should provide adequate design and operating safeguards.

TI does not warrant or represent that any license, either express or implied, is granted under any TI patent right, copyright, mask work right, or other TI intellectual property right relating to any combination, machine, or process in which TI products or services are used. Information published by TI regarding third-party products or services does not constitute a license from TI to use such products or services or a warranty or endorsement thereof. Use of such information may require a license from a third party under the patents or other intellectual property of the third party, or a license from TI under the patents or other intellectual property of TI.

Reproduction of TI information in TI data books or data sheets is permissible only if reproduction is without alteration and is accompanied by all associated warranties, conditions, limitations, and notices. Reproduction of this information with alteration is an unfair and deceptive business practice. TI is not responsible or liable for such altered documentation. Information of third parties may be subject to additional restrictions.

Resale of TI products or services with statements different from or beyond the parameters stated by TI for that product or service voids all express and any implied warranties for the associated TI product or service and is an unfair and deceptive business practice. TI is not responsible or liable for any such statements.

TI products are not authorized for use in safety-critical applications (such as life support) where a failure of the TI product would reasonably be expected to cause severe personal injury or death, unless officers of the parties have executed an agreement specifically governing such use. Buyers represent that they have all necessary expertise in the safety and regulatory ramifications of their applications, and acknowledge and agree that they are solely responsible for all legal, regulatory and safety-related requirements concerning their products and any use of TI products in such safety-critical applications, notwithstanding any applications-related information or support that may be provided by TI. Further, Buyers must fully indemnify TI and its representatives against any damages arising out of the use of TI products in such safety-critical applications.

TI products are neither designed nor intended for use in military/aerospace applications or environments unless the TI products are specifically designated by TI as military-grade or "enhanced plastic." Only products designated by TI as military-grade meet military specifications. Buyers acknowledge and agree that any such use of TI products which TI has not designated as military-grade is solely at the Buyer's risk, and that they are solely responsible for compliance with all legal and regulatory requirements in connection with such use.

TI products are neither designed nor intended for use in automotive applications or environments unless the specific TI products are designated by TI as compliant with ISO/TS 16949 requirements. Buyers acknowledge and agree that, if they use any non-designated products in automotive applications, TI will not be responsible for any failure to meet such requirements.

Following are URLs where you can obtain information on other Texas Instruments products and application solutions:

Products

Audio	www.ti.com/audio
Amplifiers	amplifier.ti.com
Data Converters	dataconverter.ti.com
DLP® Products	www.dlp.com
DSP	dsp.ti.com
Clocks and Timers	www.ti.com/clocks
Interface	interface.ti.com
Logic	logic.ti.com
Power Mgmt	power.ti.com
Microcontrollers	microcontroller.ti.com
RFID	www.ti-rfid.com
OMAP Mobile Processors	www.ti.com/omap
Wireless Connectivity	www.ti.com/wirelessconnectivity

Applications

Communications and Telecom	www.ti.com/communications
Computers and Peripherals	www.ti.com/computers
Consumer Electronics	www.ti.com/consumer-apps
Energy and Lighting	www.ti.com/energy
Industrial	www.ti.com/industrial
Medical	www.ti.com/medical
Security	www.ti.com/security
Space, Avionics and Defense	www.ti.com/space-avionics-defense
Transportation and Automotive	www.ti.com/automotive
Video and Imaging	www.ti.com/video

TI E2E Community Home Page

e2e.ti.com

Mailing Address: Texas Instruments, Post Office Box 655303, Dallas, Texas 75265
Copyright © 2011, Texas Instruments Incorporated