

Dual-channel audio amplifier

Philips dual-channel 2.2 W Class AB, BTL audio amplifier for portable applications SA58632

This dual-channel audio amplifier provides 2.2W of output power per channel with an 8-ohm load using a 9V supply. Housed in an HVQFN20 package with an exposed die-attach paddle, it delivers reduced thermal resistance and increased power dissipation.

Key features

- Wide supply voltage operating range (2 to 18V)
- Low junction-to-ambient thermal resistance (22 °C/W)
- BTL/SE select pin for speakers or headphones
- No switch-on/switch-off plops
- High power-supply ripple rejection (50dB min)
- ESD protection
- Output short-circuit-to-ground protection
- Thermal shutdown protection
- HVQFN20 package (6 x 5 x 0.85 mm)

Applications

- Professional and amateur mobile radio
- Portable consumer products (toys, games, etc.)
- PC remote speakers
- PC sound cards

The SA58632 increases dissipation capability, so it is an excellent choice for a broad range of portable applications, including mobile radios, 9 and 12V speakers, toys, games, and PC sound cards. It also supports operating systems that run between 2 and 18V.

The device is housed in a 20-pin HVQFN package with a body size of only 6 x 5mm and a lead pitch of only 0.85mm. The package has an exposed die-attach paddle, so it reduces junction-to-ambient thermal resistance and increases power dissipation.

With a 9V supply voltage and an 8Ω loudspeaker, the SA58632 delivers 2.2W of power per channel. In standby mode, it consumes less than 10μA.

The device offers a BTL/SE select option that places the outputs in a BTL (Bridge Tied Load) or SE (Single Ended) configuration.

To invoke the BTL configuration, the BTL/SE pin is taken to logic HIGH or not connected. The outputs differentially drive the speaker, so there's no need for coupling capacitors. Using a coupling capacitor for each channel, the headphone can be connected to the

PHILIPS

amplifier negative outputs. The headphone common ground pin is connected to the amplifier ground.

To invoke the SE configuration, the BTL/SE pin is taken to LOW or connected to ground. The positive outputs are muted with a DC level of one-half VCC. Using a coupling capacitor for each channel, speakers can be connected to the amplifier negative output. The speaker common ground is connected to the amplifier ground. Headphones can be connected to the negative outputs without using output coupling capacitors. The headphone common ground pin is connected to one of the amplifier positive pins.

The SA58632 can be switched to standby or mute condition via the MODE pin. The mode selection is controlled by CMOS logic levels.

Using external feedback resistors, the gain can be fixed from 6 to 30dB.

The device offers a minimum power-supply ripple-rejection (PSRR) ratio of 50dB and has integrated circuitry that protects against ESD, output short-circuit to ground, and thermal shutdown.

Ordering information

Type number	Temp range	Package	Dimension	Version
SA58632BS	-40 to +85° C	20-pin HVQFN	6 x 5 x 0.85 mm	SOT910-1

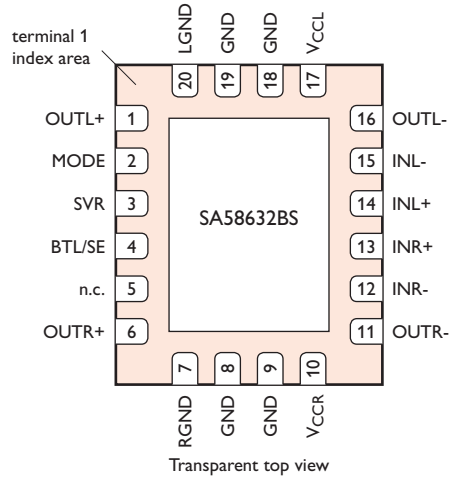

SA58632 pin configuration

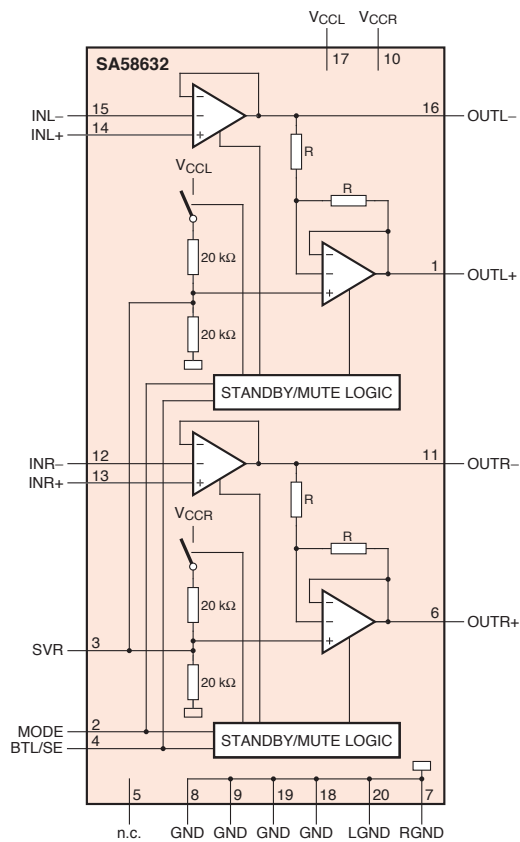

SA58632 block diagram

Philips Semiconductors

Philips Semiconductors is one of the world's top semiconductor suppliers, with 20 manufacturing and assembly sites and a sales organization that delivers in 60 countries. For a complete up-to-date list of our sales offices please visit our website <http://www.semiconductors.philips.com/sales>. For the latest news from Philips Semiconductors, please register at: www.semiconductors.philips.com/my

©2006 Koninklijke Philips Electronics N.V.

All rights reserved. Reproduction in whole or in part is prohibited without the prior written consent of the copyright owner. The information presented in this document does not form part of any quotation or contract, is believed to be accurate and reliable and may be changed without notice. No liability will be accepted by the publisher for any consequence of its use. Publication thereof does not convey nor imply any license under patent- or other industrial or intellectual property rights.

