

74ALVC16374

Low-Voltage 1.8/2.5/3.3 V 16-Bit D-Type Flip-Flop With 3.6 V-Tolerant Inputs and Outputs (3-State, Non-Inverting)

The 74ALVC16374 is an advanced performance, non-inverting 16-bit D-type flip-flop. It is designed for very high-speed, very low-power operation in 1.8 V, 2.5 V or 3.3 V systems. The ALVC16374 is byte controlled, with each byte functioning identically, but independently. Each byte has separate Output Enable and Clock Pulse inputs. These control pins can be tied together for a full 16-bit operation.

The 74ALVC16374 consists of 16 edge-triggered flip-flops with individual D-type inputs and 3.6 V-tolerant 3-state outputs. The clocks (CPn) and Output Enables ($\overline{OE}n$) are common to all flip-flops within the respective byte. The flip-flops will store the state of individual D inputs that meet the setup and hold time requirements on the LOW-to-HIGH Clock (CP) transition. With the \overline{OE} LOW, the contents of the flip-flops are available at the outputs. When the \overline{OE} is HIGH, the outputs go to the high impedance state. The \overline{OE} input level does not affect the operation of the flip-flops.

- Designed for Low Voltage Operation: $V_{CC} = 1.65\text{--}3.6\text{ V}$
- 3.6 V Tolerant Inputs and Outputs
- High Speed Operation:
 - 3.6 ns max for 3.0 to 3.6 V
 - 4.5 ns max for 2.3 to 2.7 V
 - 7.8 ns max for 1.65 to 1.95 V
- Static Drive:
 - $\pm 24\text{ mA}$ Drive at 3.0 V
 - $\pm 12\text{ mA}$ Drive at 2.3 V
 - $\pm 4\text{ mA}$ Drive at 1.65 V
- Supports Live Insertion and Withdrawal
- I_{OFF} Specification Guarantees High Impedance When $V_{CC} = 0\text{ V}^\dagger$
- Near Zero Static Supply Current in All Three Logic States (40 μA) Substantially Reduces System Power Requirements
- Latchup Performance Exceeds $\pm 250\text{ mA}$ @ 125°C
- ESD Performance: Human Body Model >2000 V; Machine Model >200 V
- Second Source to Industry Standard 74ALVC16374

† To ensure the outputs activate in the 3-state condition, the output enable pins should be connected to V_{CC} through a pull-up resistor. The value of the resistor is determined by the current sinking capability of the output connected to the \overline{OE} pin.



ON Semiconductor®

<http://onsemi.com>

MARKING DIAGRAM

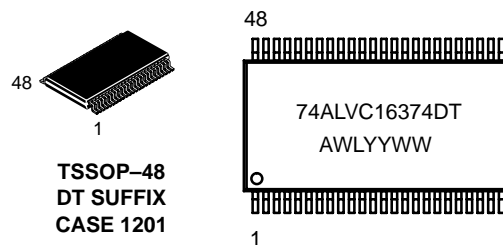

A = Assembly Location
 WL = Wafer Lot
 YY = Year
 WW = Work Week

PIN NAMES

Pins	Function
$\overline{OE}n$	Output Enable Inputs
CPn	Clock Pulse Inputs
D0–D15	Inputs
O0–O15	Outputs

ORDERING INFORMATION

Device	Package	Shipping
74ALVC16374DTR	TSSOP	2500/Tape & Reel

74ALVC16374

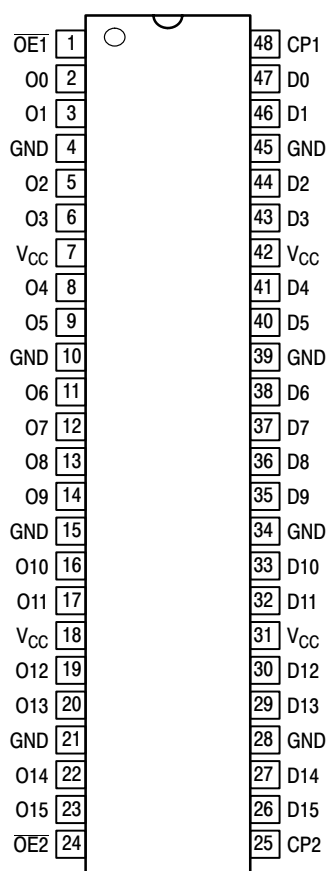

Figure 1. 48-Lead Pinout (Top View)

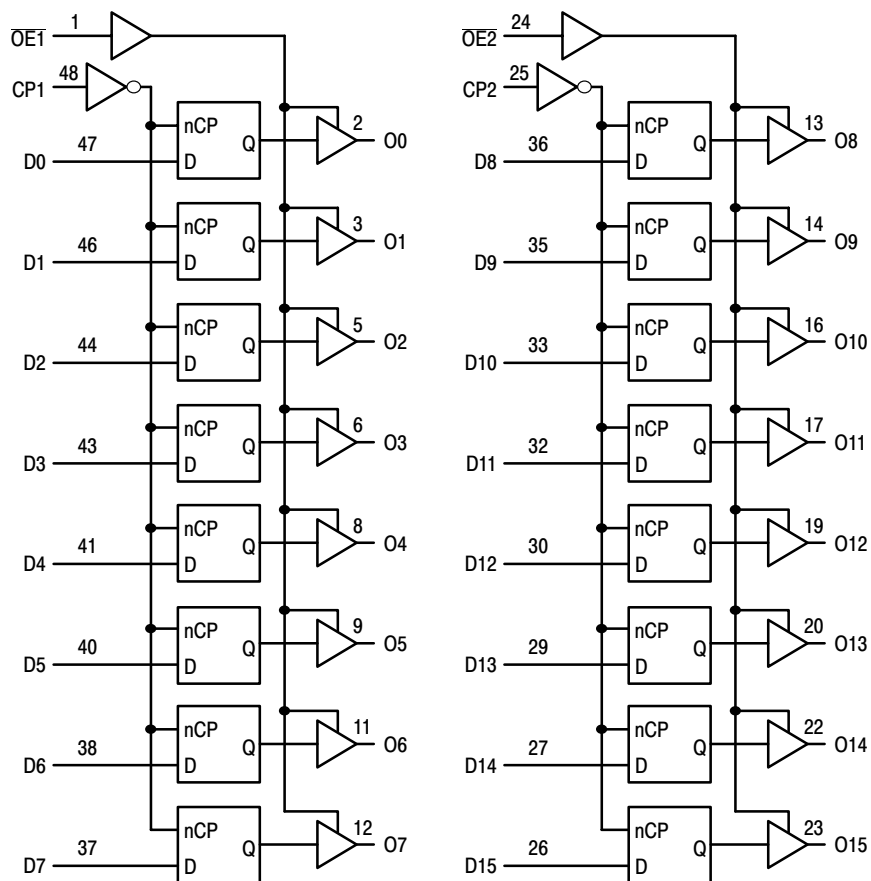

Figure 2. Logic Diagram

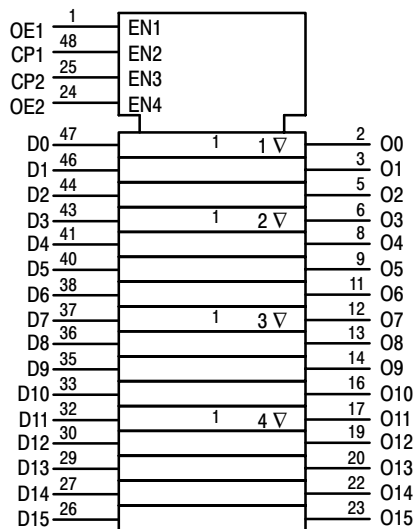

Figure 3. IEC Logic Diagram

Inputs			Outputs	Inputs			Outputs
CP1	OE1	D0:7	O0:7	CP2	OE2	D8:15	O8:15
↑	L	H	H	↑	L	H	H
↑	L	L	L	↑	L	L	L
X	L	X	O0	X	L	X	O0
X	H	X	Z	X	H	X	Z

H = High Voltage Level; L = Low Voltage Level; Z = High Impedance State; ↑ = Low-to-High Transition; X = High or Low Voltage Level and Transitions Are Acceptable, for I_{CC} reasons, DO NOT FLOAT Inputs. O0 = No Change.

74ALVC16374

MAXIMUM RATINGS (Note 1)

Symbol	Parameter	Value	Unit
V _{CC}	DC Supply Voltage	−0.5 to +4.6	V
V _I	DC Input Voltage	−0.5 to +4.6	V
V _O	DC Output Voltage	−0.5 to +4.6	V
I _{IK}	DC Input Diode Current V _I < GND	−50	mA
I _{OK}	DC Output Diode Current V _O < GND	−50	mA
I _O	DC Output Sink/Source Current	±50	mA
I _{CC}	DC Supply Current per Supply Pin	±100	mA
I _{GND}	DC Ground Current per Ground Pin	±100	mA
T _{STG}	Storage Temperature Range	−65 to +150	°C
T _L	Lead Temperature, 1 mm from Case for 10 Seconds	260	°C
T _J	Junction Temperature Under Bias	+150	°C
θ _{JA}	Thermal Resistance (Note 2)	90	°C/W
MSL	Moisture Sensitivity	Level 1	
FR	Flammability Rating Oxygen Index: 30% – 35%	UL–94–VO (0.125 in)	
V _{ESD}	ESD Withstand Voltage Human Body Model (Note 3) Machine Model (Note 4) Charged Device Model (Note 5)	> 2000 > 200 N/A	V
I _{LATCH-UP}	Latch–Up Performance Above V _{CC} and Below GND at 125°C (Note 6)	±250	mA

Maximum Ratings are those values beyond which damage to the device may occur. Exposure to these conditions or conditions beyond those indicated may adversely affect device reliability. Functional operation under absolute maximum–rated conditions is not implied. Functional operation should be restricted to the Recommended Operating Conditions.

1. I_O absolute maximum rating must be observed.
2. Measured with minimum pad spacing on an FR4 board, using 10 mm–by–1 inch, 2–ounce copper trace with no air flow.
3. Tested to EIA/JESD22–A114–A.
4. Tested to EIA/JESD22–A115–A.
5. Tested to JESD22–C101–A.
6. Tested to EIA/JESD78.

RECOMMENDED OPERATING CONDITIONS

Symbol	Parameter	Min	Typ	Max	Unit	
V _{CC}	Supply Voltage	Operating	1.65	3.3	3.6	V
		Data Retention Only	1.2	3.3	3.6	
V _I	Input Voltage (Note 7)	−0.5		3.6	V	
V _O	Output Voltage (Active State) (3–State)	0		V _{CC}	V	
		0		3.6		
T _A	Operating Free–Air Temperature	−40		+85	°C	
Δt/ΔV	Input Transition Rise or Fall Rate, V _{IN} from 0.8 V to 2.0 V, V _{CC} = 2.5 V ±0.2 V V _{CC} = 3.0 V ±0.3 V	0		20	ns/V	
		0		10		

7. Unused inputs may not be left open. All inputs must be tied to a high–logic voltage level or a low–logic input voltage level.

74ALVC16374

DC ELECTRICAL CHARACTERISTICS

Symbol	Characteristic	Condition	T _A = -40°C to +85°C		Unit
			Min	Max	
V _{IH}	HIGH Level Input Voltage (Note 8)	1.65 V ≤ V _{CC} < 2.3 V	0.65 x V _{CC}		V
		2.3 V ≤ V _{CC} ≤ 2.7 V	1.7		
		2.7 V < V _{CC} ≤ 3.6 V	2.0		
V _{IL}	LOW Level Input Voltage (Note 8)	1.65 V ≤ V _{CC} < 2.3 V		0.35 x V _{CC}	V
		2.3 V ≤ V _{CC} ≤ 2.7 V		0.7	
		2.7 V < V _{CC} ≤ 3.6 V		0.8	
V _{OH}	HIGH Level Output Voltage	1.65 V ≤ V _{CC} ≤ 3.6 V; I _{OH} = -100 μA	V _{CC} - 0.2		V
		V _{CC} = 1.65 V; I _{OH} = -4 mA	1.2		
		V _{CC} = 2.3 V; I _{OH} = -6 mA	2.0		
		V _{CC} = 2.3 V; I _{OH} = -12 mA	1.7		
		V _{CC} = 2.7 V; I _{OH} = -12 mA	2.2		
		V _{CC} = 3.0 V; I _{OH} = -12 mA	2.4		
		V _{CC} = 3.0 V; I _{OH} = -24 mA	2.0		
V _{OL}	LOW Level Output Voltage	1.65 V ≤ V _{CC} ≤ 3.6 V; I _{OL} = 100 μA		0.2	V
		V _{CC} = 1.65 V; I _{OL} = 4 mA		0.45	
		V _{CC} = 2.3 V; I _{OL} = 6 mA		0.4	
		V _{CC} = 2.3 V; I _{OL} = 12 mA		0.7	
		V _{CC} = 2.7 V; I _{OL} = 12 mA		0.4	
		V _{CC} = 3.0 V; I _{OL} = 24 mA		0.55	
I _I	Input Leakage Current	1.65 V ≤ V _{CC} ≤ 3.6 V; 0 V ≤ V _I ≤ 3.6 V		±5.0	μA
I _{OZ}	3-State Output Current	1.65 V ≤ V _{CC} ≤ 3.6 V; 0 V ≤ V _O ≤ 3.6 V; V _I = V _{IH} or V _{IL}		±10	μA
I _{OFF}	Power-Off Leakage Current	V _{CC} = 0 V; V _I or V _O = 3.6 V		10	μA
I _{CC}	Quiescent Supply Current (Note 9)	1.65 V ≤ V _{CC} ≤ 3.6 V; V _I = GND or V _{CC}		40	μA
		1.65 V ≤ V _{CC} ≤ 3.6 V; 3.6 V ≤ V _I , V _O ≤ 3.6 V		±40	μA
ΔI _{CC}	Increase in I _{CC} per Input	2.7 V < V _{CC} ≤ 3.6 V; V _{IH} = V _{CC} - 0.6 V		750	μA

8. These values of V_I are used to test DC electrical characteristics only.

9. Outputs disabled or 3-state only.

74ALVC16374

AC CHARACTERISTICS (Note 10; $t_R = t_F = 2.0$ ns; $C_L = 30$ pF; $R_L = 500 \Omega$)

Symbol	Parameter	Waveform	Limits						Unit
			$T_A = -40^\circ\text{C to } +85^\circ\text{C}$						
			$V_{CC} = 3.0$ V to 3.6 V		$V_{CC} = 2.3$ V to 2.7 V		$V_{CC} = 1.65$ to 1.95 V		
			Min	Max	Min	Max	Min	Max	
f_{max}	Clock Pulse Frequency	1	250		200		100		MHz
t_{PLH} t_{PHL}	Propagation Delay CP to On	1	1.1 1.1	3.6 3.6	1.0 1.0	4.5 4.5	1.5 1.5	7.8 7.8	ns
t_{PZH} t_{PZL}	Output Enable Time to High and Low Level	2	1.0 1.0	4.7 4.7	1.0 1.0	6.0 6.0	1.5 1.5	9.2 9.2	ns
t_{PHZ} t_{PLZ}	Output Disable Time From High and Low Level	2	1.4 1.4	4.1 4.1	1.2 1.2	5.1 5.1	1.5 1.5	6.8 6.8	ns
t_s	Setup Time, High or Low Dn to CP	3	1.1		1.0		2.5		ns
t_h	Hold Time, High or Low Dn to CP	3	1.4		1.5		1.0		ns
t_w	CP Pulse Width, High	3	3.3		3.3		4.0		ns
t_{OSHL} t_{OSLH}	Output-to-Output Skew (Note 11)			0.5 0.5		0.5 0.5		0.75 0.75	ns

10. For $C_L = 50$ pF, add approximately 300 ps to the AC maximum specification.

11. Skew is defined as the absolute value of the difference between the actual propagation delay for any two separate outputs of the same device. The specification applies to any outputs switching in the same direction, either HIGH-to-LOW (t_{OSHL}) or LOW-to-HIGH (t_{OSLH}); parameter guaranteed by design.

CAPACITIVE CHARACTERISTICS

Symbol	Parameter	Condition	Typical	Unit
C_{IN}	Input Capacitance	Note 12	6	pF
C_{OUT}	Output Capacitance	Note 12	7	pF
C_{PD}	Power Dissipation Capacitance	Note 12, 10MHz	20	pF

12. $V_{CC} = 1.8, 2.5$ or 3.3 V; $V_I = 0$ V or V_{CC} .

74ALVC16374

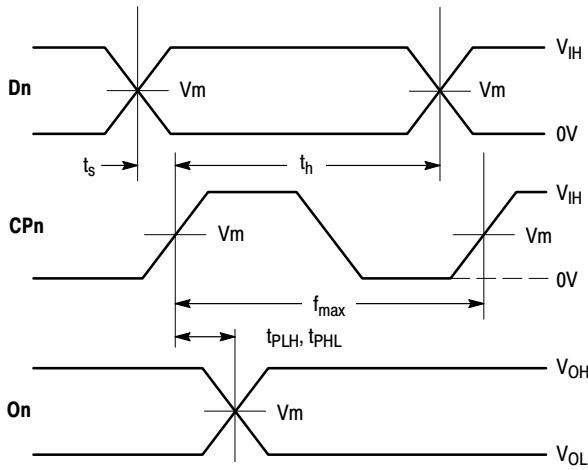

WAVEFORM 1 - PROPAGATION DELAYS, SETUP AND HOLD TIMES
 $t_R = t_F = 2.0\text{ns}$, 10% to 90%; $f = 1\text{MHz}$; $t_W = 500\text{ns}$

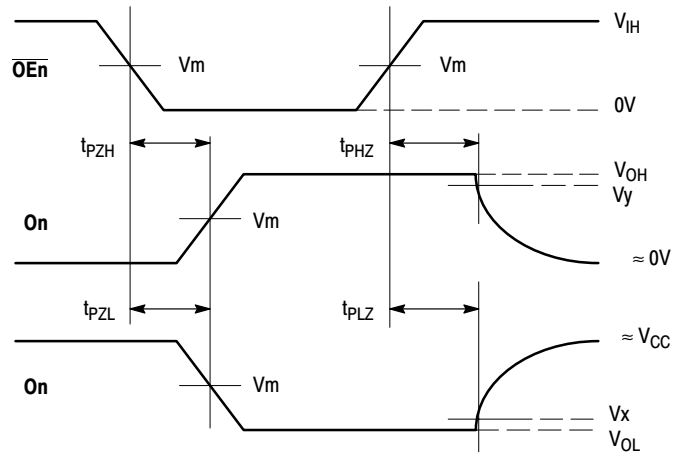

WAVEFORM 2 - OUTPUT ENABLE AND DISABLE TIMES
 $t_R = t_F = 2.0\text{ns}$, 10% to 90%; $f = 1\text{MHz}$; $t_W = 500\text{ns}$

Figure 4. AC Waveforms

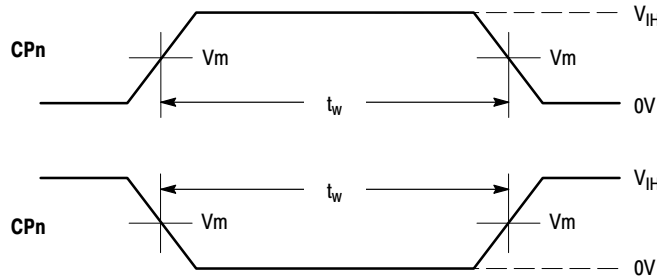

WAVEFORM 3 - PULSE WIDTH
 $t_R = t_F = 2.0\text{ns}$ (or fast as required) from 10% to 90%

Figure 5. AC Waveforms

Symbol	V_{CC}		
	3.3 V ± 0.3 V	2.5 V ± 0.2 V	1.8 V ± 0.15 V
V_{IH}	2.7 V	V_{CC}	V_{CC}
V_m	1.5 V	$V_{CC}/2$	$V_{CC}/2$
V_x	$V_{OL} + 0.3$ V	$V_{OL} + 0.15$ V	$V_{OL} + 0.15$ V
V_y	$V_{OH} - 0.3$ V	$V_{OH} - 0.15$ V	$V_{OH} - 0.15$ V

74ALVC16374

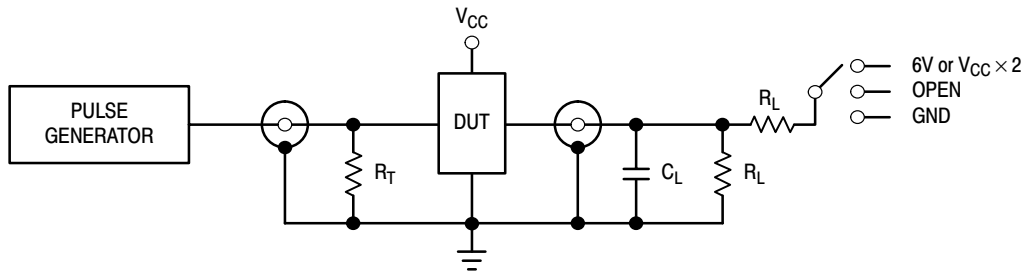

TEST	SWITCH
t_{PLH} , t_{PHL}	Open
t_{PZL} , t_{PLZ}	6 V at $V_{CC} = 3.3 \pm 0.3$ V; $V_{CC} \times 2$ at $V_{CC} = 2.5 \pm 0.2$ V; 1.8 V ± 0.15 V
t_{PZH} , t_{PHZ}	GND

$C_L = 30$ pF or equivalent (Includes jig and probe capacitance)

$R_L = 500 \Omega$ or equivalent

$R_T = Z_{OUT}$ of pulse generator (typically 50 Ω)

Figure 6. Test Circuit

74ALVC16374

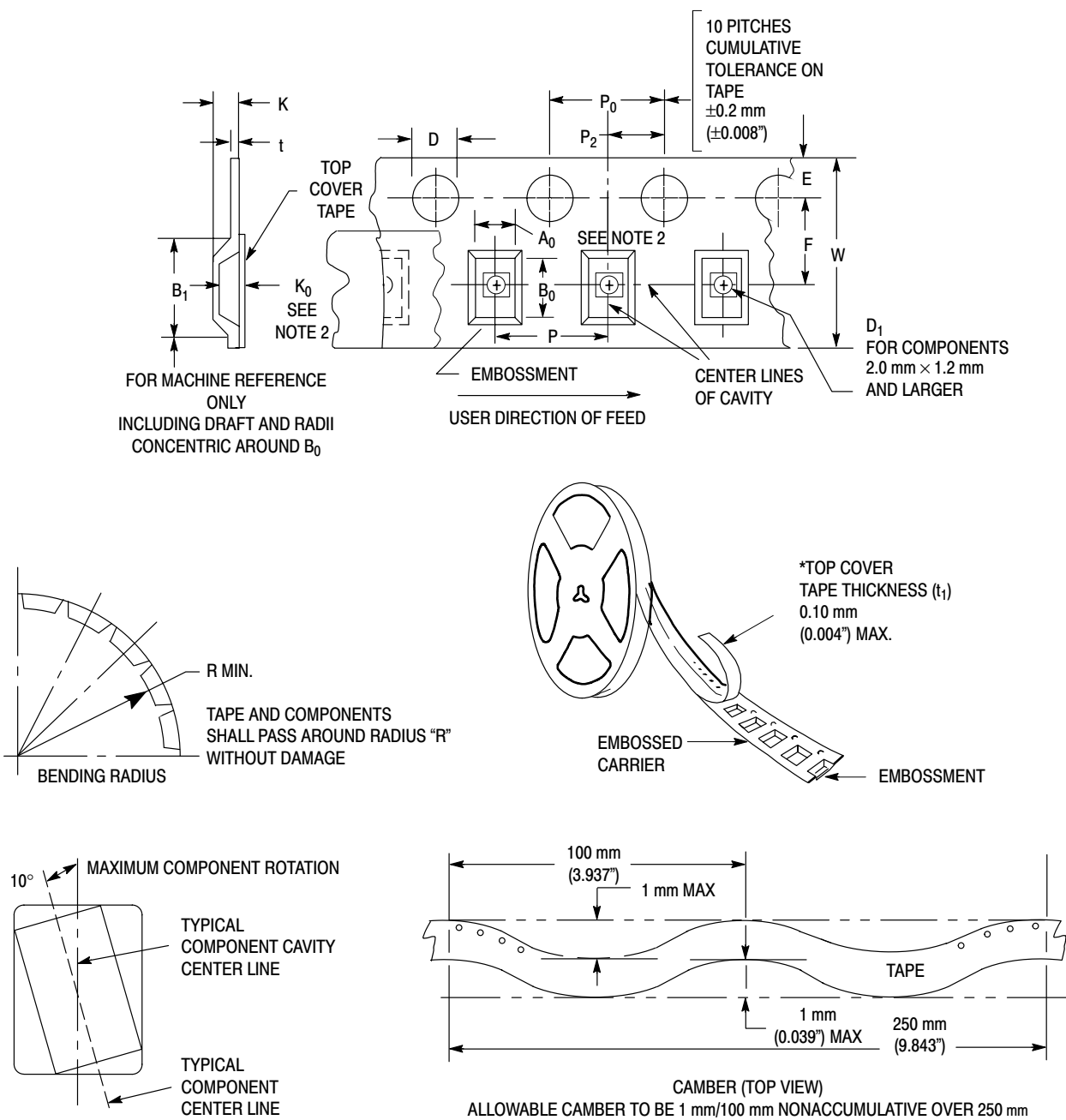

Figure 7. Carrier Tape Specifications

EMBOSSED CARRIER DIMENSIONS (See Notes 1 and 2)

Tape Size	B_1 Max	D	D_1	E	F	K	P	P_0	P_2	R	T	W
24mm	20.1mm (0.791")	1.5 + 0.1mm - 0.0 (0.059 +0.004" -0.0)	1.5mm Min (0.060")	1.75 ± 0.1 mm (0.069 ± 0.004 ")	11.5 ± 0.10 mm (0.453 ± 0.004 ")	11.9 mm Max (0.468")	16.0 ± 0.1 mm (0.63 ± 0.004 ")	4.0 ± 0.1 mm (0.157 ± 0.004 ")	2.0 ± 0.1 mm (0.079 ± 0.004 ")	30 mm (1.18")	0.6 mm (0.024")	24.3 mm (0.957")

1. Metric Dimensions Govern—English are in parentheses for reference only.
2. A_0 , B_0 , and K_0 are determined by component size. The clearance between the components and the cavity must be within 0.05 mm min to 0.50 mm max. The component cannot rotate more than 10° within the determined cavity.

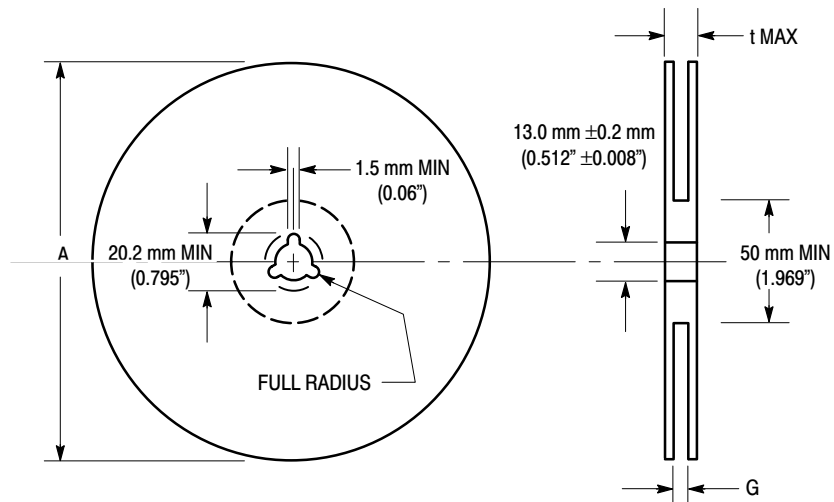

Figure 8. Reel Dimensions

REEL DIMENSIONS

Tape Size	A Max	G	t Max
24 mm	360 mm (14.173")	24.4 mm + 2.0 mm, -0.0 (0.961" + 0.078", -0.00)	30.4 mm (1.197")

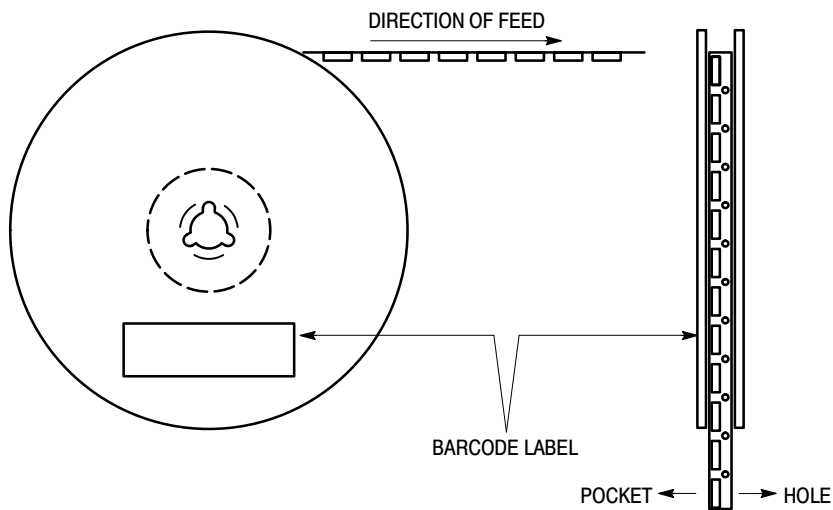

Figure 9. Reel Winding Direction

74ALVC16374

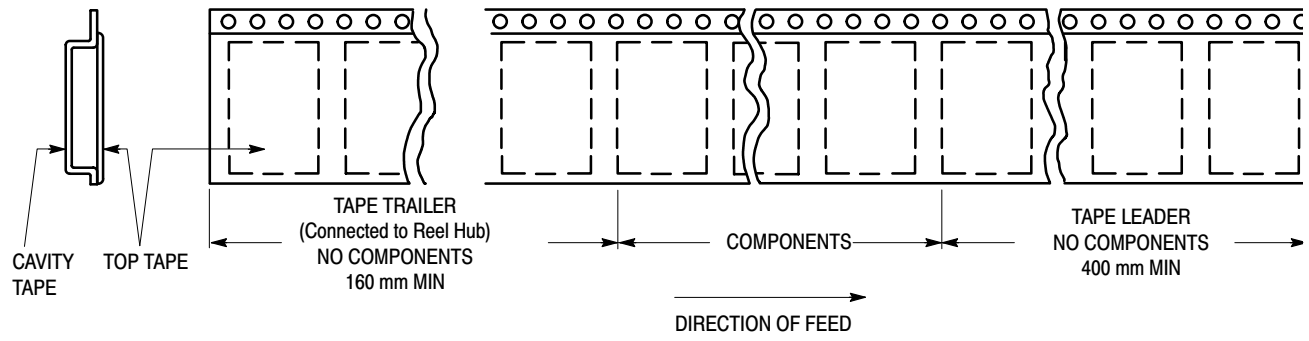

Figure 10. Tape Ends for Finished Goods

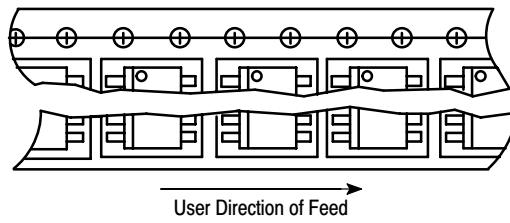

Figure 11. Reel Configuration

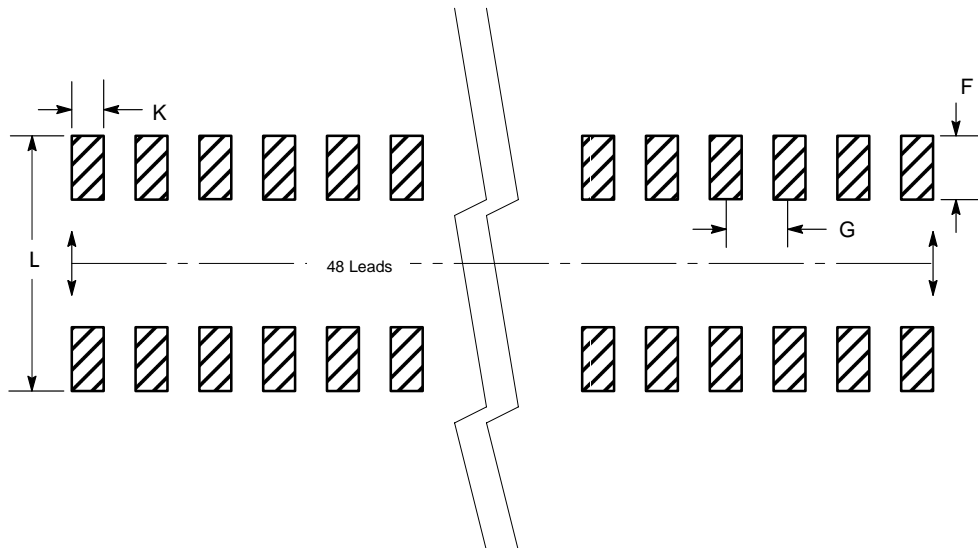
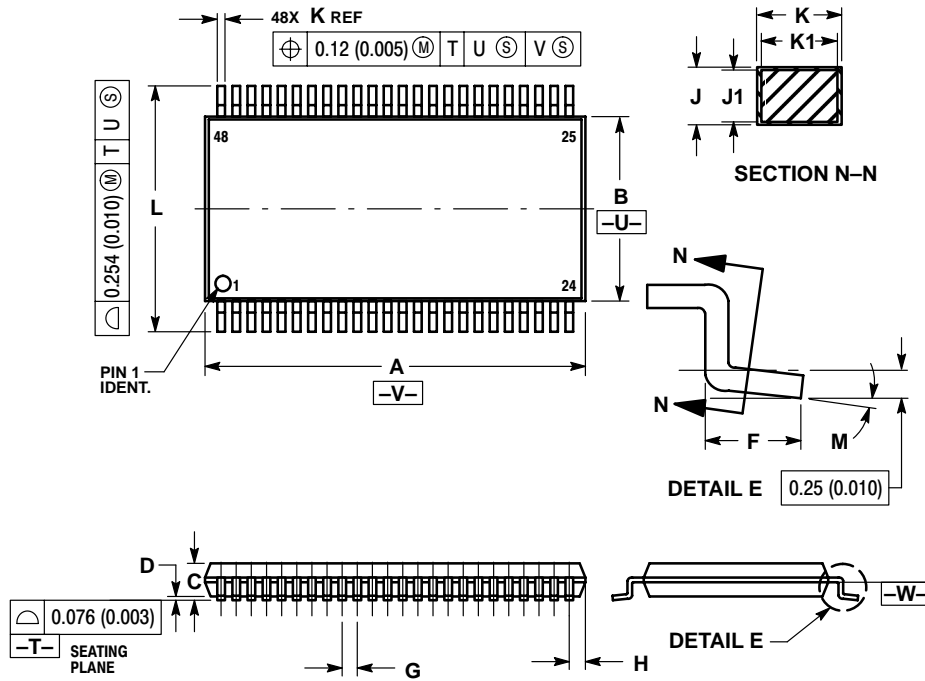

Figure 12. Package Footprint

74ALVC16374

PACKAGE DIMENSIONS

TSSOP
DT SUFFIX
CASE 1201-01
ISSUE A



NOTES:

1. DIMENSIONING AND TOLERANCING PER ANSI Y14.5M, 1982.
2. CONTROLLING DIMENSION: MILLIMETER.
3. DIMENSIONS A AND B DO NOT INCLUDE MOLD FLASH, PROTRUSIONS OR GATE BURRS. MOLD FLASH OR GATE BURRS SHALL NOT EXCEED 0.15 (0.006) PER SIDE.
4. DIMENSION K DOES NOT INCLUDE DAMBAR PROTRUSION. ALLOWABLE DAMBAR PROTRUSION SHALL BE 0.08 (0.003) TOTAL IN EXCESS OF THE K DIMENSION AT MAXIMUM MATERIAL CONDITION.
5. TERMINAL NUMBERS ARE SHOWN FOR REFERENCE ONLY.
6. DIMENSIONS A AND B ARE TO BE DETERMINED AT DATUM PLANE -W-.

DIM	MILLIMETERS		INCHES	
	MIN	MAX	MIN	MAX
A	12.40	12.60	0.488	0.496
B	6.00	6.20	0.236	0.244
C	---	1.10	---	0.043
D	0.05	0.15	0.002	0.006
F	0.50	0.75	0.020	0.030
G	0.50 BSC		0.0197 BSC	
H	0.37	---	0.015	---
J	0.09	0.20	0.004	0.008
J1	0.09	0.16	0.004	0.006
K	0.17	0.27	0.007	0.011
K1	0.17	0.23	0.007	0.009
L	7.95	8.25	0.313	0.325
M	0 °	8 °	0 °	8 °

ON Semiconductor and  are registered trademarks of Semiconductor Components Industries, LLC (SCILLC). SCILLC reserves the right to make changes without further notice to any products herein. SCILLC makes no warranty, representation or guarantee regarding the suitability of its products for any particular purpose, nor does SCILLC assume any liability arising out of the application or use of any product or circuit, and specifically disclaims any and all liability, including without limitation special, consequential or incidental damages. "Typical" parameters which may be provided in SCILLC data sheets and/or specifications can and do vary in different applications and actual performance may vary over time. All operating parameters, including "Typicals" must be validated for each customer application by customer's technical experts. SCILLC does not convey any license under its patent rights nor the rights of others. SCILLC products are not designed, intended, or authorized for use as components in systems intended for surgical implant into the body, or other applications intended to support or sustain life, or for any other application in which the failure of the SCILLC product could create a situation where personal injury or death may occur. Should Buyer purchase or use SCILLC products for any such unintended or unauthorized application, Buyer shall indemnify and hold SCILLC and its officers, employees, subsidiaries, affiliates, and distributors harmless against all claims, costs, damages, and expenses, and reasonable attorney fees arising out of, directly or indirectly, any claim of personal injury or death associated with such unintended or unauthorized use, even if such claim alleges that SCILLC was negligent regarding the design or manufacture of the part. SCILLC is an Equal Opportunity/Affirmative Action Employer.

PUBLICATION ORDERING INFORMATION

Literature Fulfillment:

Literature Distribution Center for ON Semiconductor
P.O. Box 5163, Denver, Colorado 80217 USA
Phone: 303-675-2175 or 800-344-3860 Toll Free USA/Canada
Fax: 303-675-2176 or 800-344-3867 Toll Free USA/Canada
Email: ONlit@hibbertco.com

N. American Technical Support: 800-282-9855 Toll Free USA/Canada

JAPAN: ON Semiconductor, Japan Customer Focus Center
2-9-1 Kamimeguro, Meguro-ku, Tokyo, Japan 153-0051
Phone: 81-3-5773-3850
Email: r14525@onsemi.com

ON Semiconductor Website: <http://onsemi.com>

For additional information, please contact your local Sales Representative.