

Distributed by:

JAMECO[®]
ELECTRONICS

www.Jameco.com ♦ 1-800-831-4242

The content and copyrights of the attached
material are the property of its owner.

Jameco Part Number 784870

BSR16

PNP General Purpose Amplifier

- This device designed for use as general purpose amplifier and switches requiring collector currents to 500mA.
- Sourced from Process 63.
- See BCW68G for Characteristics.

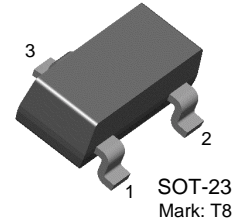

1. Base 2. Emitter 3. Collector

PNP Epitaxial Silicon Transistor

Absolute Maximum Ratings* $T_a=25^\circ\text{C}$ unless otherwise noted

Symbol	Parameter	Value	Units
V_{CEO}	Collector-Emitter Voltage	-60	V
V_{CBO}	Collector-Base Voltage	-60	V
V_{EBO}	Emitter-Base Voltage	-5.0	V
I_{C}	Collector Current - Continuous	-800	mA
$T_{\text{J}}, T_{\text{ST}}$	Operating and Storage Junction Temperature Range	-55 ~ +150	$^\circ\text{C}$

* These ratings are limiting values above which the serviceability of any semiconductor device may be impaired.

NOTES:

- 1) These ratings are based on a maximum junction temperature of 150 degrees C.
- 2) These are steady state limits. The factory should be consulted on applications involving pulsed or low duty cycle operations.

Electrical Characteristics $T_a=25^\circ\text{C}$ unless otherwise noted

Symbol	Parameter	Test Condition	Min.	Typ.	Max.	Units
Off Characteristics						
$BV_{(BR)CEO}$	Collector-Emitter Breakdown Voltage	$I_C = -10\text{mA}, I_B = 0$	-60			V
$BV_{(BR)CBO}$	Collector-Base Breakdown Voltage	$I_C = -100\mu\text{A}, I_E = 0$	-60			V
$BV_{(BR)EBO}$	Emitter-Base Breakdown Voltage	$I_E = -10\mu\text{A}, I_C = 0$	-5.0			V
I_{CBO}	Collector Cut-off Current	$V_{CB} = -50\text{V}$ $V_{CB} = -50\text{V}, T_A = 150^\circ\text{C}$			-10 -10	nA μA
I_{CEX}	Collector Cut-off Current	$V_{CE} = -30\text{V}, V_{EB} = -0.5\text{V}$			-50	nA
I_{BEX}	Reverse Base Current	$V_{CE} = -30\text{V}, V_{EB} = -3.0\text{V}$			-50	nA

On Characteristics						
h_{FE}	DC Current Gain	$I_C = -0.1\text{mA}, V_{CE} = -10\text{V}$ $I_C = -1.0\text{mA}, V_{CE} = -10\text{V}$ $I_C = -10\text{mA}, V_{CE} = -10\text{V}$ $I_C = -150\text{mA}, V_{CE} = -10\text{V}$ $I_C = -500\text{mA}, V_{CE} = -10\text{V}$	75 100 100 100 50	300		
$V_{CE(sat)}$	Collector-Emitter Saturation Voltage	$I_C = -150\text{mA}, I_B = -15\text{mA}$ $I_C = -500\text{mA}, I_B = -50\text{mA}$			-0.4 -1.6	V V
$V_{BE(sat)}$	Base-Emitter Saturation Voltage	$I_C = -150\text{mA}, I_B = -15\text{mA}$ $I_C = -500\text{mA}, I_B = -50\text{mA}$			-1.3 -2.6	V V

Small Signal Characteristics						
f_T	Current Gain Bandwidth Product	$I_C = -50\text{mA}, V_{CE} = -20\text{V},$ $f = 100\text{MHz}, T_A = 25^\circ\text{C}$	200			MHz
C_{cb}	Output Capacitance	$V_{CB} = -10\text{V}, I_E = 0, f = 1.0\text{MHz}$			8.0	pF
C_{eb}	Emitter-Base Capacitance	$V_{CB} = -2.0\text{V}, I_E = 0, f = 1.0\text{MHz}$			30	pF

Switching Characteristics						
t_{on}	Turn-On Time	$V_{CC} = -30\text{V}, I_C = -150\text{mA},$ $I_{B1} = -15\text{mA}$			45	ns
t_d	Delay Time				10	ns
t_r	Rise Time				40	ns
t_{off}	Turn-Off Time	$V_{CC} = -30\text{V}, I_C = -150\text{mA},$ $I_{B1} = I_{B2} = -15\text{mA}$			100	ns
t_s	Storage Time				80	ns
t_f	Fall Time				30	ns

Thermal Characteristics $T_A=25^\circ\text{C}$ unless otherwise noted

Symbol	Parameter	Max.	Units
P_D	Total Device Dissipation Derate above 25°C	350 2.8	mW $\text{mW}/^\circ\text{C}$
$R_{\theta JA}$	Thermal Resistance, Junction to Ambient	357	$^\circ\text{C}/\text{W}$

* Device mounted on FR-4 PCB 40mm \times 40mm \times 1.5mm

Package Dimensions

SOT-23

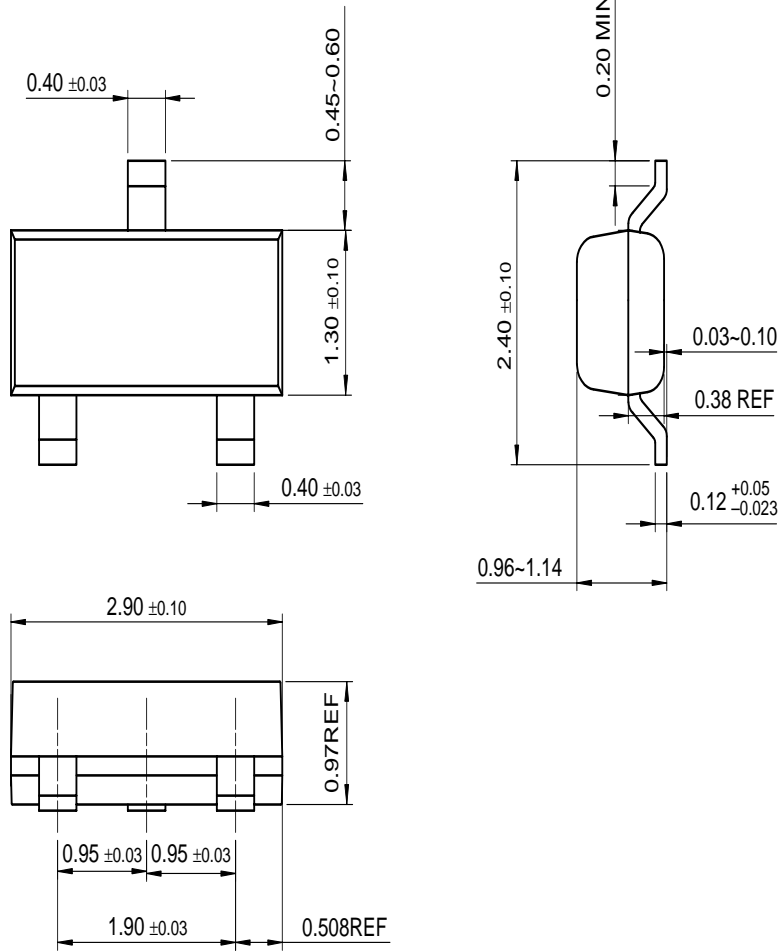

Dimensions in Millimeters

TRADEMARKS

The following are registered and unregistered trademarks Fairchild Semiconductor owns or is authorized to use and is not intended to be an exhaustive list of all such trademarks.

ACE ^x TM	FAST ^r TM	OPTOLOGIC [®]	SMART START TM	VCX TM
Bottomless TM	FRFET TM	OPTOPLANAR TM	SPM TM	
CoolFET TM	GlobalOptoisolator TM	PACMAN TM	Stealth TM	
CROSSVOLT TM	GTO TM	POP TM	SuperSOT TM -3	
DOME TM	HiSeC TM	Power247 TM	SuperSOT TM -6	
EcoSPARK TM	I ² C TM	PowerTrench [®]	SuperSOT TM -8	
E ² CMOS TM	ISOPLANAR TM	QFET TM	SyncFET TM	
EnSigna TM	LittleFET TM	QS TM	TinyLogic TM	
FACT TM	MicroFET TM	QT Optoelectronics TM	TruTranslation TM	
FACT Quiet series TM	MicroPak TM	Quiet Series TM	UHC TM	
FAST [®]	MICROWIRE TM	SLIENT SWITCHER [®]	UltraFET [®]	

DISCLAIMER

FAIRCHILD SEMICONDUCTOR RESERVES THE RIGHT TO MAKE CHANGES WITHOUT FURTHER NOTICE TO ANY PRODUCTS HEREIN TO IMPROVE RELIABILITY, FUNCTION OR DESIGN. FAIRCHILD DOES NOT ASSUME ANY LIABILITY ARISING OUT OF THE APPLICATION OR USE OF ANY PRODUCT OR CIRCUIT DESCRIBED HEREIN; NEITHER DOES IT CONVEY ANY LICENSE UNDER ITS PATENT RIGHTS, NOR THE RIGHTS OF OTHERS.

LIFE SUPPORT POLICY

FAIRCHILD'S PRODUCTS ARE NOT AUTHORIZED FOR USE AS CRITICAL COMPONENTS IN LIFE SUPPORT DEVICES OR SYSTEMS WITHOUT THE EXPRESS WRITTEN APPROVAL OF FAIRCHILD SEMICONDUCTOR CORPORATION.

As used herein:

1. Life support devices or systems are devices or systems which, (a) are intended for surgical implant into the body, or (b) support or sustain life, or (c) whose failure to perform when properly used in accordance with instructions for use provided in the labeling, can be reasonably expected to result in significant injury to the user.
2. A critical component is any component of a life support device or system whose failure to perform can be reasonably expected to cause the failure of the life support device or system, or to affect its safety or effectiveness.

PRODUCT STATUS DEFINITIONS

Definition of Terms

Datasheet Identification	Product Status	Definition
Advance Information	Formative or In Design	This datasheet contains the design specifications for product development. Specifications may change in any manner without notice.
Preliminary	First Production	This datasheet contains preliminary data, and supplementary data will be published at a later date. Fairchild Semiconductor reserves the right to make changes at any time without notice in order to improve design.
No Identification Needed	Full Production	This datasheet contains final specifications. Fairchild Semiconductor reserves the right to make changes at any time without notice in order to improve design.
Obsolete	Not In Production	This datasheet contains specifications on a product that has been discontinued by Fairchild semiconductor. The datasheet is printed for reference information only.