



## FSA1156, FSA1157 Low- $R_{ON}$ , Low-Voltage SPST Analog Switch

### Features

- Maximum  $0.95\Omega$   $R_{ON}$  for 4.5V Supply at 25°C
- $0.3\Omega$  Maximum  $R_{ON}$  Flatness at 4.5V Supply
- Broad  $V_{CC}$  Operating Range: 1.65V to 5.5v
- Fast Turn-On and Turn-Off Time
- Over-Voltage Tolerant, TTL-Compatible Control Input
- Available in space-saving 6-lead, MicroPak™ and SC70 Packages

### Description

The FSA1156 and FSA1157 are high-performance Single-Pole / Single-Throw (SPST) analog switches. The devices feature ultra-low  $R_{ON}$  of  $0.75\Omega$  (typical) and operate over a wide  $V_{CC}$  range of 1.65 V to 5.5 V. The devices are fabricated with sub-micron CMOS technology to achieve fast switching speeds. The select input is TTL-level compatible. The FSA1156 has normally open operation; the FSA1157 has normally closed operation.

### Ordering Information

Part Number	Top Mark	Package Description	Packing Method
FSA1156P6X	156	6-Lead SC70, EIAJ SC88, 1.25mm Wide	3000 Units Tape and Reel
FSA1156L6X	EH	6-Lead MicroPak™, 1.0mm Wide	5000 Units Tape and Reel
FSA1157P6X	157	6-Lead SC70, EIAJ SC88, 1.25mm Wide	3000 Units Tape and Reel
FSA1157L6X	EJ	6-Lead MicroPak™, 1.0mm Wide	5000 Units Tape and Reel

## Pin Configurations

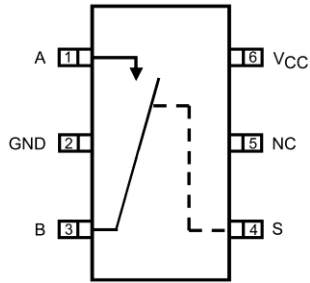

Figure 1. FSA1156 SC70 Top View (Normally Open)

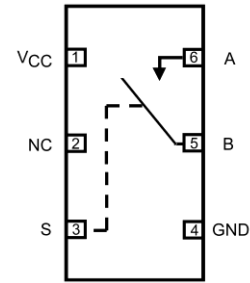

Figure 2. FSA1156 MicroPak™ Top Through View (Normally Open)

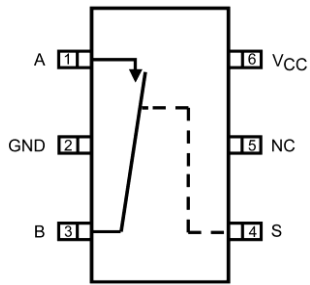

Figure 3. FSA1157 SC70 Top View (Normally Closed)

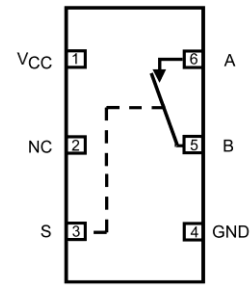

Figure 4. FSA1157 MicroPak™ Top Through View (Normally Closed)

## Pin Definitions

Pin# SC70	Pin# Micropak™	Name	Description
1	6	A	Data Ports
2	4	GND	Ground
3	5	B	Data Ports
4	3	S	Control Input
5	2	NC	No Connect
6	1	VCC	Supply Voltage

## Truth Table

Control Input (S)	FSA1156	FSA1157
Low	OFF	ON
High	ON	OFF

## Absolute Maximum Ratings

Stresses exceeding the absolute maximum ratings may damage the device. The device may not function or be operable above the recommended operating conditions and stressing the parts to these levels is not recommended. In addition, extended exposure to stresses above the recommended operating conditions may affect device reliability. The absolute maximum ratings are stress ratings only.

Symbol	Parameter	Min.	Max.	Unit
$V_{CC}$	Supply Voltage	-0.5	6.0	V
$V_{SW}$	Switch Voltage <sup>(1)</sup>	-0.5	$V_{CC} + 0.5$	V
$V_{IN}$	Input Voltage <sup>(1)</sup>	-0.5	6.0	V
$I_{IK}$	Input Diode Current		-50	mA
$I_{SW}$	Switch Current		200	mA
$I_{SWPEAK}$	Peak Switch Current (Pulse at 1ms Duration, <10% Duty Cycle)		400	mA
$P_D$	Power Dissipation at 85°C, SC70 Package		180	mW
$T_{STG}$	Storage Temperature Range	-65	+150	°C
$T_J$	Maximum Junction Temperature		+150	°C
$T_L$	Lead Temperature (Soldering, 10 seconds)		+260	°C
ESD	Electrostatic Discharge Capability	Human Body Model, JESD22-A114		8000 V

**Note:**

1. Input and output negative ratings may be exceeded if input and output diode current ratings are observed.

## Recommended Operating Conditions

The Recommended Operating Conditions table defines the conditions for actual device operation. Recommended operating conditions are specified to ensure optimal performance to the datasheet specifications. Fairchild does not recommend exceeding them or designing to Absolute Maximum Ratings.

Symbol	Parameter	Min.	Max.	Unit
$V_{CC}$	Supply Voltage	1.65	5.50	V
$V_{CNTRL}$	Control Input Voltage <sup>(2)</sup>	0	$V_{CC}$	V
$V_{SW}$	Switch Input Voltage	0	$V_{CC}$	V
$T_A$	Operating Temperature	-40	+85	°C
$\theta_{JA}$	Thermal Resistance in Still Air, SC70 Package		350	°C/W

**Note:**

2. Control input must be held HIGH or LOW and it must not float.

## DC Electrical Characteristics

Typical values are at 25°C unless otherwise specified.

Symbol	Parameter	Conditions	V <sub>CC</sub> (V)	Ambient Temperature (T <sub>A</sub> )					Units
				+25°C			-40 to +85°C		
				Min.	Typ.	Max.	Min.	Max.	
V <sub>IH</sub>	Input Voltage High		2.7 to 3.6				2.0		V
			4.5 to 5.5				2.4		
V <sub>IL</sub>	Input Voltage Low		2.7 to 3.6					0.6	V
			4.5 to 5.5					0.8	
I <sub>IN</sub>	Control Input Leakage	V <sub>IN</sub> =0 V to V <sub>CC</sub>	2.7 to 3.6				-1.0	1.0	μA
			4.5 to 5.5				-1.0	1.0	
I <sub>NO(OFF)</sub> , I <sub>NC(OFF)</sub>	Off Leakage Current	A=1 V, 4.5 V, B=4.5 V, 1 V	5.5	-2		2	20	20	nA
I <sub>A(ON)</sub>	On Leakage Current	A=1 V, 4.5 V, B=1 V, 4.5 V, or Floating	5.5	-4		4	-40	40	nA
R <sub>ON</sub>	Switch On Resistance <sup>(3)</sup>	I <sub>OUT</sub> =100 mA, B=1.5 V	2.7		1.4	2.1		2.5	Ω
		I <sub>OUT</sub> =100 mA, B=3.5 V	4.5		0.75	0.90		1.00	
R <sub>FLAT(ON)</sub>	On Resistance Flatness <sup>(4)</sup>	I <sub>OUT</sub> =100 mA, B <sub>0</sub> =0 V, 0.75 V, 1.5 V	2.7		0.6				Ω
		I <sub>OUT</sub> =100 mA, B <sub>0</sub> =0 V, 1 V, 2 V	4.5		0.1	0.2		0.3	
I <sub>CC</sub>	Quiescent Supply Current	V <sub>IN</sub> =0 V or V <sub>CC</sub> , I <sub>OUT</sub> =0 V	3.6		0.1	0.5		1.0	μA
			5.5		0.1	0.5		1.0	

### Notes:

- On resistance is determined by the voltage drop between the A and B pins at the indicated current through the switch.
- Flatness is defined as the difference between the maximum and minimum value of on resistance over the specified range of conditions.

## AC Electrical Characteristics

Typical values are at 25°C unless otherwise specified.

Symbol	Parameter	Conditions	V <sub>CC</sub> (V)	Ambient Temperature (T <sub>A</sub> )					Units	Figure
				+25°C			-40 to +85°C			
				Min.	Typ.	Max.	Min.	Max.		
t <sub>ON</sub>	Turn-On Time	B =1.5 V, R <sub>L</sub> =50 Ω, C <sub>L</sub> =35 pF	2.7 to 3.6		30	40		45	ns	Figure 7
		B=3.0 V, R <sub>L</sub> =50 Ω, C <sub>L</sub> =35 pF	4.5 to 5.5		15	20		25		
t <sub>OFF</sub>	Turn-Off Time	B=1.5 V, R <sub>L</sub> =50 Ω, C <sub>L</sub> =35 pF	2.7 to 3.6		25	35		45	ns	Figure 7
		B=3.0 V, R <sub>L</sub> =50 Ω, C <sub>L</sub> =35 pF	4.5 to 5.5		22	30		40		
Q	Charge Injection	C <sub>L</sub> =1.0 nF, V <sub>GE</sub> =0 V, R <sub>GEN</sub> =0Ω	2.7 to 3.6		10				pC	Figure 8
			4.5 to 5.5		20					
OIRR	Off Isolation	f=1 MHz, R <sub>L</sub> =50 Ω	2.7 to 3.6		-65				dB	Figure 9
			4.5 to 5.5		-65					
BW	-3db Bandwidth	R <sub>L</sub> =50 Ω	2.7 to 3.6		300				MHz	Figure 10
			4.5 to 5.5		300					
THD	Total Harmonic Distortion	R <sub>L</sub> =600 Ω, V <sub>IN</sub> =0.5 V <sub>PP</sub> , f=20 Hz to 20 kHz	2.7 to 3.6		0.001				%	Figure 11
			4.5 to 5.5		0.001					

## Capacitance

Symbol	Parameter	Conditions	V <sub>CC</sub> (V)	Ambient Temperature +25°			Units	Figure
				Min.	Typ.	Max.		
C <sub>IN</sub>	Control Pin Input Capacitance	f=1 MHz	0.0		3		pF	Figure 12
C <sub>OFF</sub>	B Port Off Capacitance	f=1 MHz	4.5		20		pF	Figure 12
C <sub>ON</sub>	On Capacitance	f=1 MHz	4.5		65		pF	Figure 12

### Typical Performance Characteristics

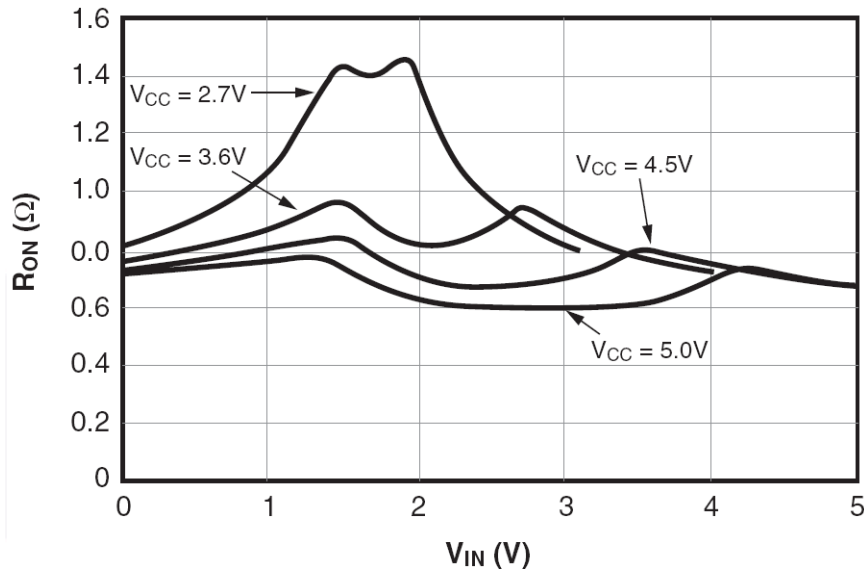

Figure 5. On Resistance vs. Input Voltage, Over Supply Voltage,  $T_A=25^\circ\text{C}$

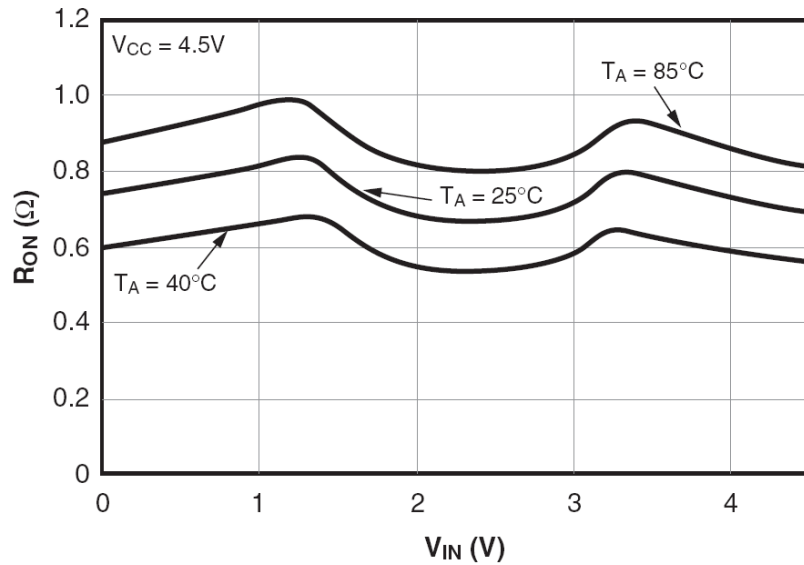
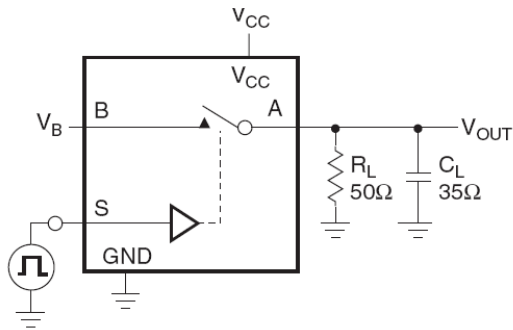
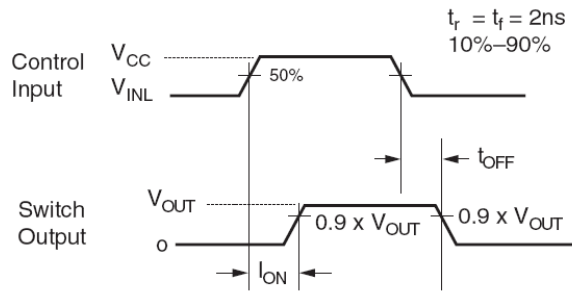

Figure 6. On Resistance vs. Input Voltage, Over Temperature

### AC Loadings and Waveforms



$C_L$  Includes Fixture and Stray Capacitance



Logic Input Waveforms Inverted for Switches that have the Opposite Logic Sense

Figure 7. Turn On / Off Timing

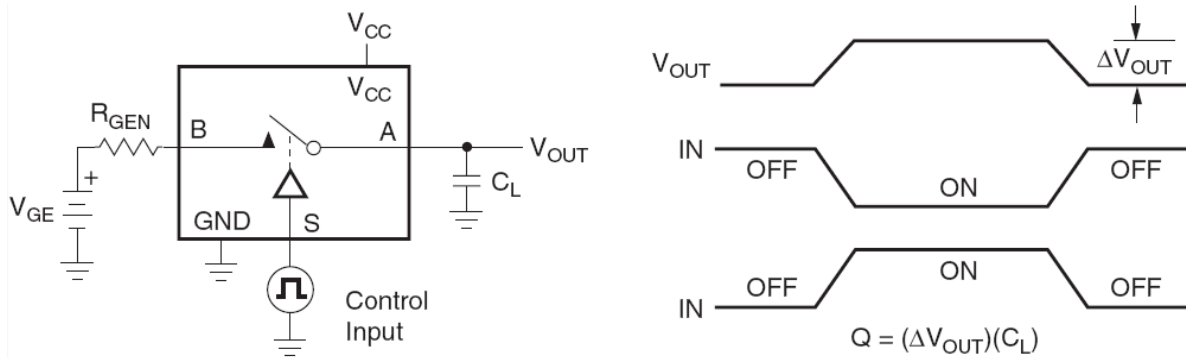

Figure 8. Charge Injection

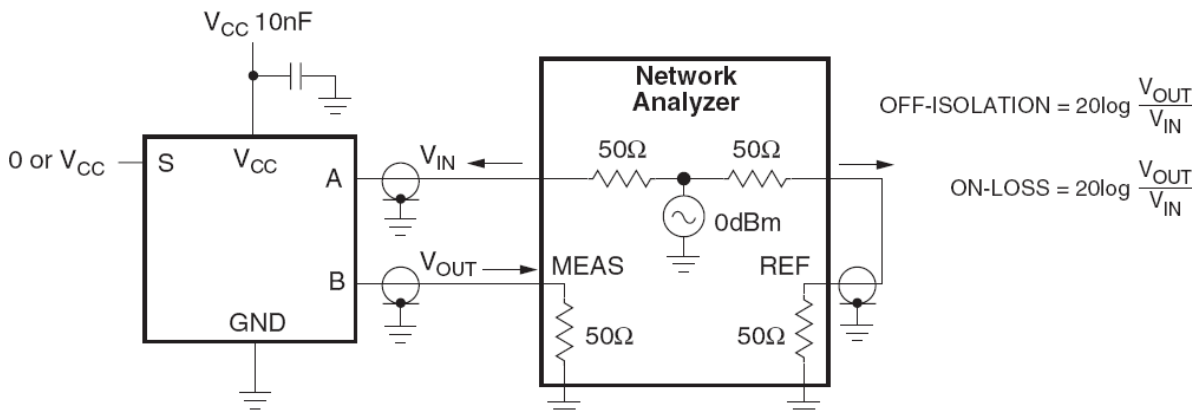
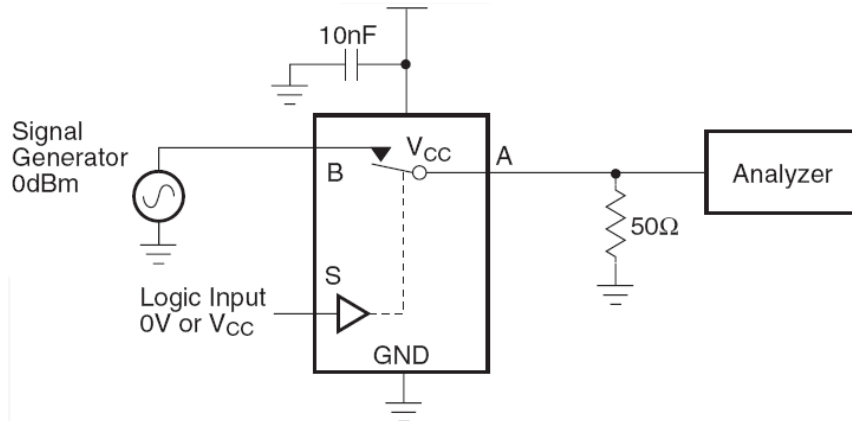
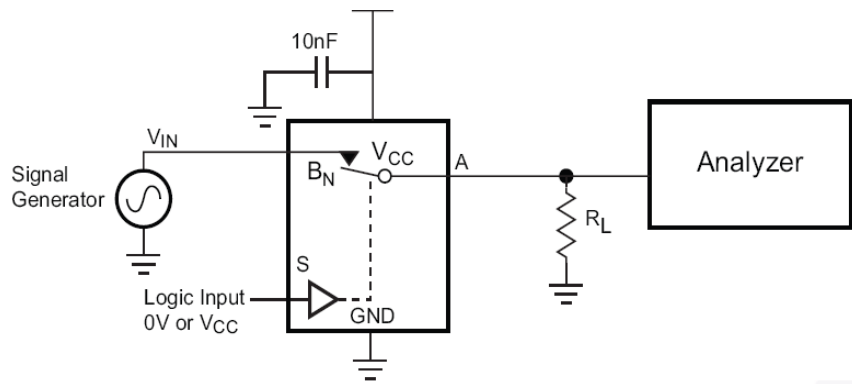

Figure 9. Off Isolation

**AC Loadings and Waveforms (Continued)**



**Figure 10. Bandwidth**



**Figure 11. Harmonic Distortion**

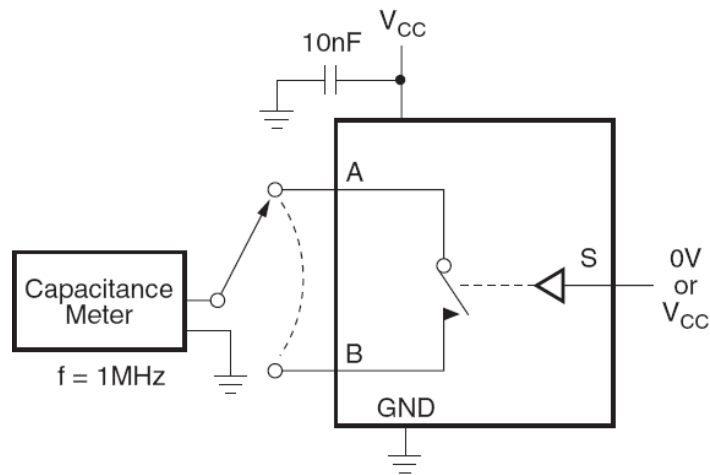

**Figure 12. On / Off Capacitance**

## Physical Dimensions

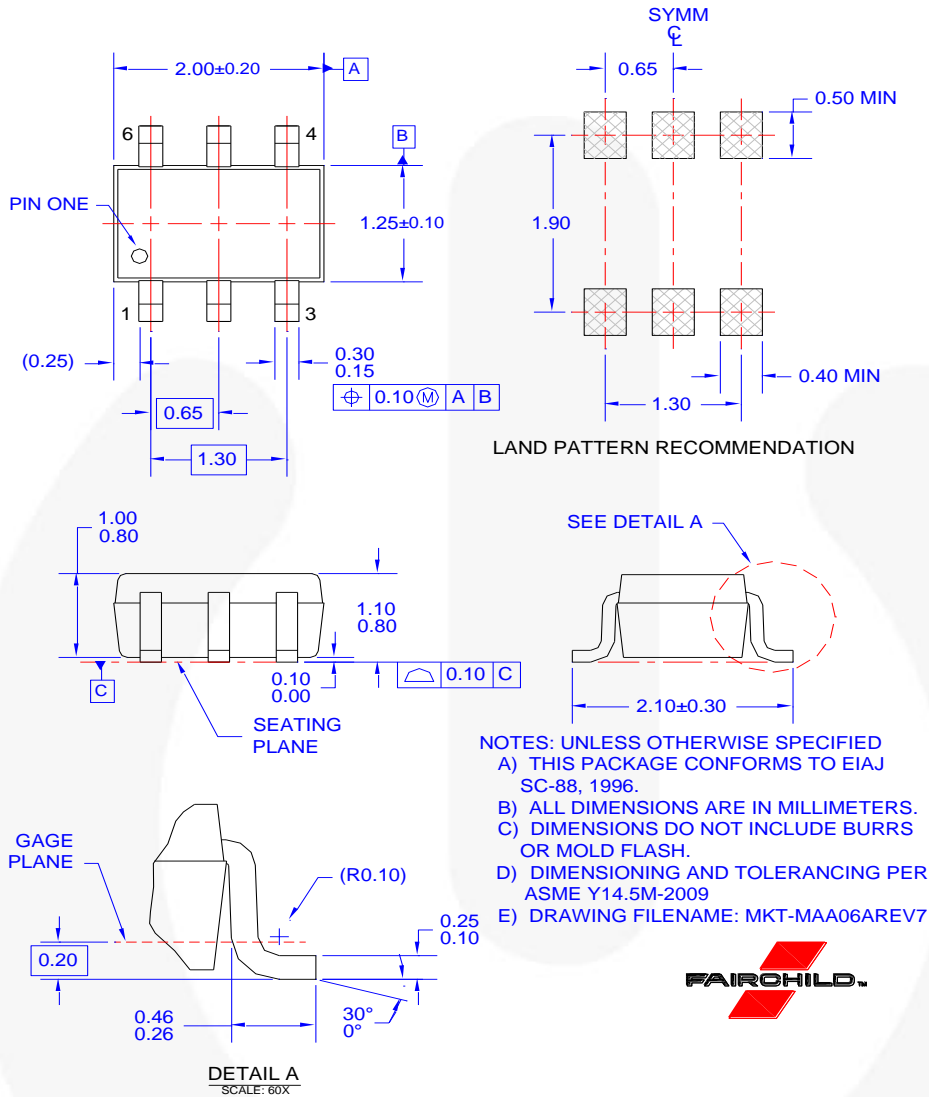

Figure 13. 6-Lead, SC70, EIAJ SC88 1.25mm Wide Package

## Tape and Reel Specifications

Please visit Fairchild Semiconductor's online packaging area for the most recent tape and reel specifications:  
[http://www.fairchildsemi.com/products/analog/pdf/sc70-6\\_tr.pdf](http://www.fairchildsemi.com/products/analog/pdf/sc70-6_tr.pdf)

Package Designator	Tape Section	Cavity Number	Cavity Status	Cover Type Status
P6X	Leader (Start End)	125 (Typical)	Empty	Sealed
	Carrier	3000	Filled	Sealed
	Trailer (Hub End)	75 (Typical)	Empty	Sealed

**Physical Dimensions (Continued)**

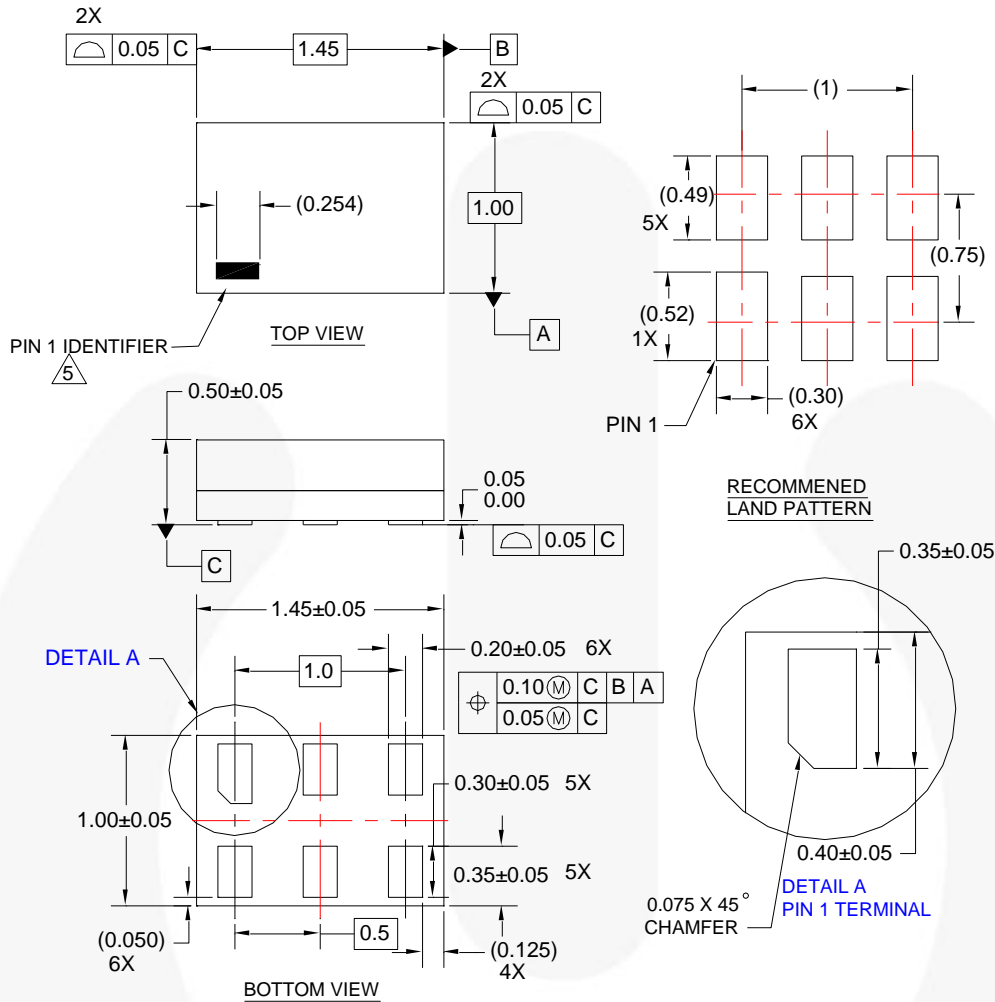

**NOTES:**

1. CONFORMS TO JEDEC STANDARD MO-252 VARIATION UAAD
2. DIMENSIONS ARE IN MILLIMETERS
3. DRAWING CONFORMS TO ASME Y14.5M-2009
4. LANDPATTERN RECOMMENDATION PER FSC
5. PIN ONE IDENTIFIER IS 2X LENGTH OF ANY OTHER LINE IN THE MARK CODE LAYOUT.
6. FILENAME AND REVISION: MAC06AREV6



**Figure 14. 6-Lead, Micropak™ 1.0mm Wide Package**

**Tape and Reel Specifications**





Please visit Fairchild Semiconductor's online packaging area for the most recent tape and reel specifications:  
[http://www.fairchildsemi.com/products/logic/pdf/micropak\\_tr.pdf](http://www.fairchildsemi.com/products/logic/pdf/micropak_tr.pdf)

Package Designator	Tape Section	Cavity Number	Cavity Status	Cover Type Status
L6X	Leader (Start End)	125 (Typical)	Empty	Sealed
	Carrier	5000	Filled	Sealed
	Trailer (Hub End)	75 (Typical)	Empty	Sealed



## TRADEMARKS

The following includes registered and unregistered trademarks and service marks, owned by Fairchild Semiconductor and/or its global subsidiaries, and is not intended to be an exhaustive list of all such trademarks.

AccuPower™	F-PFS™	OPTOPLANAR®	
AttitudeEngine™	FRFET®		TinyBoost®
Awinda®	Global Power Resource™	Power Supply WebDesigner™	TinyBuck®
AX-CAP®*	GreenBridge™	PowerTrench®	TinyCalc™
BitSiC™	Green FPS™	PowerXS™	TinyLogic®
Build it Now™	Green FPS™ e-Series™	Programmable Active Droop™	TINYOPTO™
CorePLUS™	Gmax™	QFET®	TinyPower™
CorePOWER™	GTO™	QS™	TinyPWM™
CROSSVOLT™	IntelliMAX™	Quiet Series™	TinyWire™
CTL™	ISOPLANAR™	RapidConfigure™	TranSiC™
Current Transfer Logic™	Making Small Speakers Sound Louder and Better™		TriFault Detect™
DEUXPEED®	MegaBuck™	Saving our world, 1mW/W/kW at a time™	TRUECURRENT®*
Dual Cool™	MICROCOUPLER™	SignalWise™	µSerDes™
EcoSPARK®	MicroFET™	SmartMax™	
EfficientMax™	MicroPak™	SMART START™	UHC®
ESBC™	MicroPak2™	Solutions for Your Success™	Ultra FRFET™
	MillerDrive™	SPM®	UniFET™
Fairchild®	MotionMax™	STEALTH™	VCX™
Fairchild Semiconductor®	MotionGrid®	SuperFET®	VisualMax™
FACT Quiet Series™	MTI®	SuperSOT™-3	VoltaPlus™
FACT®	MTX®	SuperSOT™-6	XS™
FastvCore™	MVN®	SuperSOT™-8	Xsens™
FETBench™	mWSaver®	SupreMOS®	仙童®
FPS™	OptoHiT™	SyncFET™	
	OPTOLOGIC®	Sync-Lock™	

\* Trademarks of System General Corporation, used under license by Fairchild Semiconductor.

## DISCLAIMER

FAIRCHILD SEMICONDUCTOR RESERVES THE RIGHT TO MAKE CHANGES WITHOUT FURTHER NOTICE TO ANY PRODUCTS HEREIN TO IMPROVE RELIABILITY, FUNCTION, OR DESIGN. TO OBTAIN THE LATEST, MOST UP-TO-DATE DATASHEET AND PRODUCT INFORMATION, VISIT OUR WEBSITE AT [HTTP://WWW.FAIRCHILDSEMI.COM](http://www.fairchildsemi.com). FAIRCHILD DOES NOT ASSUME ANY LIABILITY ARISING OUT OF THE APPLICATION OR USE OF ANY PRODUCT OR CIRCUIT DESCRIBED HEREIN; NEITHER DOES IT CONVEY ANY LICENSE UNDER ITS PATENT RIGHTS, NOR THE RIGHTS OF OTHERS. THESE SPECIFICATIONS DO NOT EXPAND THE TERMS OF FAIRCHILD'S WORLDWIDE TERMS AND CONDITIONS, SPECIFICALLY THE WARRANTY THEREIN, WHICH COVERS THESE PRODUCTS.

## AUTHORIZED USE

Unless otherwise specified in this data sheet, this product is a standard commercial product and is not intended for use in applications that require extraordinary levels of quality and reliability. This product may not be used in the following applications, unless specifically approved in writing by a Fairchild officer: (1) automotive or other transportation, (2) military/aerospace, (3) any safety critical application – including life critical medical equipment – where the failure of the Fairchild product reasonably would be expected to result in personal injury, death or property damage. Customer's use of this product is subject to agreement of this Authorized Use policy. In the event of an unauthorized use of Fairchild's product, Fairchild accepts no liability in the event of product failure. In other respects, this product shall be subject to Fairchild's Worldwide Terms and Conditions of Sale, unless a separate agreement has been signed by both Parties.

## ANTI-COUNTERFEITING POLICY

Fairchild Semiconductor Corporation's Anti-Counterfeiting Policy. Fairchild's Anti-Counterfeiting Policy is also stated on our external website, [www.fairchildsemi.com](http://www.fairchildsemi.com), under Terms of Use

Counterfeiting of semiconductor parts is a growing problem in the industry. All manufacturers of semiconductor products are experiencing counterfeiting of their parts. Customers who inadvertently purchase counterfeit parts experience many problems such as loss of brand reputation, substandard performance, failed applications, and increased cost of production and manufacturing delays. Fairchild is taking strong measures to protect ourselves and our customers from the proliferation of counterfeit parts. Fairchild strongly encourages customers to purchase Fairchild parts either directly from Fairchild or from Authorized Fairchild Distributors who are listed by country on our web page cited above. Products customers buy either from Fairchild directly or from Authorized Fairchild Distributors are genuine parts, have full traceability, meet Fairchild's quality standards for handling and storage and provide access to Fairchild's full range of up-to-date technical and product information. Fairchild and our Authorized Distributors will stand behind all warranties and will appropriately address any warranty issues that may arise. Fairchild will not provide any warranty coverage or other assistance for parts bought from Unauthorized Sources. Fairchild is committed to combat this global problem and encourage our customers to do their part in stopping this practice by buying direct or from authorized distributors.

## PRODUCT STATUS DEFINITIONS

### Definition of Terms

Datasheet Identification	Product Status	Definition
Advance Information	Formative / In Design	Datasheet contains the design specifications for product development. Specifications may change in any manner without notice.
Preliminary	First Production	Datasheet contains preliminary data; supplementary data will be published at a later date. Fairchild Semiconductor reserves the right to make changes at any time without notice to improve design.
No Identification Needed	Full Production	Datasheet contains final specifications. Fairchild Semiconductor reserves the right to make changes at any time without notice to improve the design.
Obsolete	Not In Production	Datasheet contains specifications on a product that is discontinued by Fairchild Semiconductor. The datasheet is for reference information only.

Rev. 177