

## FSUSB23 — High-Speed, USB2.0 (480Mbps) Switch

### Features

- 10µA Maximum I<sub>CC1</sub> Current over an Expanded Control
- Voltage Range: V<sub>IN</sub> = 2.6V, V<sub>CC</sub> = 3.6V)
- Lower Capacitance: C<sub>ON</sub> = 9pF Typical
- 7Ω Typical On Resistance (R<sub>ON</sub>)
- -3dB Bandwidth: > 720MHz
- Low Power Consumption: 1mA Maximum
- Wide -3db Bandwidth: > 720MHz
- Packaged in:
  - 10-Lead MicroPak™ (1.6 x 2.1mm)
  - 16-Lead DQFN (2.5 x3.5mm)
- 7kV I/O to GND ESD Performance

### Description

The FSUSB23 is a low-power, high-bandwidth analog switch specifically designed for high speed USB 2.0 applications. The FSUSB23 features very low quiescent current even when the control voltage is lower than the V<sub>CC</sub> supply. This feature services mobile handset applications, allowing direct interface with the baseband processor general-purpose I/Os.

Typical applications involve switching in portables and consumer applications, such as cell phones, digital cameras, and notebooks with hubs or controllers. The wide bandwidth (>720MHz) of this switch exceeds the bandwidth needed to pass the third harmonic, which results in signals with minimum edge and phase distortion. Superior channel-to-channel crosstalk results in minimal interference.

### Applications

- Cell phone, PDA, Digital Camera, and Notebook
- LCD Monitor, TV, and Set-Top Box

### Ordering Information

Part Number	Top Mark	Operating Temperature Range	Package
FSUSB23L10X	EZ	-40 to +85°C	10-Lead MicroPak™ 1.6 x 2.1mm, JEDEC MO-255B
FSUSB23BQX	USB23	-40 to +85°C	16-Terminal Depopulated Quad Very-Thin Flat Pack No Leads (DQFN), JEDEC MO-241, 2.5 x 3.5mm

MicroPak™ is a trademark of Fairchild Semiconductor Corporation.

All packages are lead free per JEDEC: J-STD-020B standard.

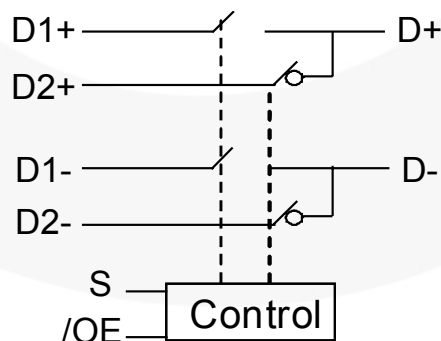


Figure 1. Analog Symbol

## Pin Configurations

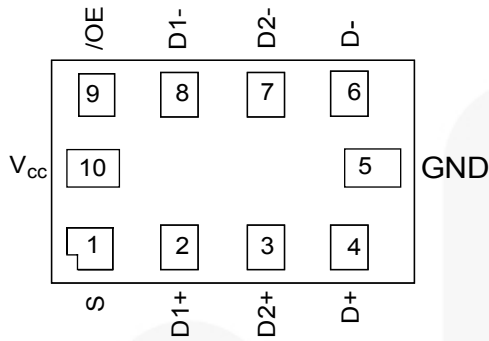


Figure 2. Pad Assignments for MicroPak™ (Top Through View)

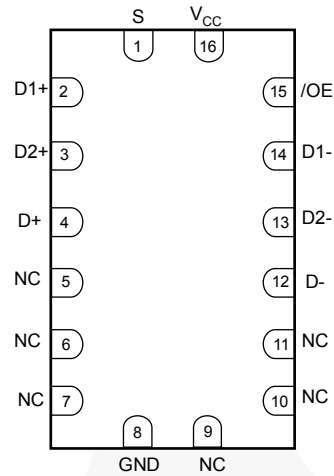


Figure 3. Pin Assignments for DQFN (Top Through View)

## Pin Definitions

Pin # Micropak	Pin # DQFN	Pin Name	Pin Description
1	1	S	Switch Select
9	15	/OE	Bus Switch Enable
2, 3, 4, 6, 7, 8	2, 3, 4, 12, 13, 14	D+, D-, Dn+, Dn-	Data Port
10	16	V <sub>CC</sub>	Supply Voltage
5	8	GND	Ground
	5, 6, 7, 9, 10, 11	NC	No Connect

## Truth Table

Sel	/OE	Function
X	HIGH	Disconnect
LOW	LOW	D+, D- = D1 <sub>n</sub>
HIGH	LOW	D+, D- = D2 <sub>n</sub>

## Absolute Maximum Ratings

Stresses exceeding the absolute maximum ratings may damage the device. The device may not function or be operable above the recommended operating conditions and stressing the parts to these levels is not recommended. In addition, extended exposure to stresses above the recommended operating conditions may affect device reliability. The absolute maximum ratings are stress ratings only.

Symbol	Parameter	Min.	Max.	Unit
V <sub>CC</sub>	Supply Voltage	-0.5	4.6	V
V <sub>SW</sub>	DC Switch Voltage <sup>(1)</sup>	-0.5	V <sub>CC</sub> + 0.5	V
V <sub>IN</sub>	DC Input Voltage <sup>(1)</sup>	-0.5	4.6	V
I <sub>IK</sub>	DC Input Diode Current	-50		mA
I <sub>OUT</sub>	DC Output Current		50	mA
T <sub>STG</sub>	Storage Temperature	-65	+150	°C
ESD	Human Body Model, JEDEC: JESD22-A114	All Pins	7	kV
		I/O to GND	7	

**Note:**

- The input and output negative ratings may be exceeded if the input and output diode current ratings are observed. DC switch voltage may never exceed 4.6V.

## Recommended Operating Conditions

The Recommended Operating Conditions table defines the conditions for actual device operation. Recommended operating conditions are specified to ensure optimal performance to the datasheet specifications. Fairchild does not recommend exceeding them or designing to Absolute Maximum Ratings.

Symbol	Parameter	Min.	Max.	Unit
V <sub>CC</sub>	Supply Voltage	3.0	3.6	V
V <sub>CNTRL</sub>	Control Input Voltage <sup>(2)(3)</sup>	0	V <sub>CC</sub>	V
V <sub>SW</sub>	Switch Input Voltage	0	V <sub>CC</sub>	V
T <sub>A</sub>	Operating Temperature	-40	+85	°C
Θ <sub>JA</sub>	Thermal Resistance		250	°C/W
			Micropak	

**Note:**

- The input and output negative voltage ratings may be exceeded if the input and output diode current ratings are observed. DC switch voltage may never exceed 4.6V.
- The control input must be held HIGH or LOW; it must not float.

## DC Electrical Characteristics

All typical values are at 25°C unless otherwise specified.

Symbol	Parameter	Conditions	V <sub>CC</sub> (V)	T <sub>A</sub> =- 40°C to +85°C			Units
				Min.	Typ.	Max.	
V <sub>IK</sub>	Clamp Diode Voltage	I <sub>IN</sub> =-18mA	3.0			-1.2	V
V <sub>IH</sub>	Input Voltage High		3.0 to 3.6	1.2			V
V <sub>IL</sub>	Input Voltage Low		3.0 to 3.6			.50	V
I <sub>IN</sub>	Control Input Leakage	V <sub>IN</sub> =0V to V <sub>CC</sub>	3.6			1	μA
I <sub>OZ</sub>	Off State Leakage	0 ≤ D <sub>n</sub> , D1 <sub>n</sub> , D2 <sub>n</sub> ≤ V <sub>CC</sub>				1	μA
R <sub>ON</sub>	Switch On Resistance <sup>(4)</sup>	V <sub>SW</sub> =0.4V, I <sub>ON</sub> =-8mA	3.0		6	9	Ω
		V <sub>SW</sub> =0.8V, I <sub>ON</sub> =-8mA			7	10	
ΔR <sub>ON</sub>	Delta R <sub>ON</sub> <sup>(5)</sup>	V <sub>IN</sub> =0.4V, I <sub>ON</sub> =-8mA	3.0		0.3		Ω
R <sub>ON Flat</sub>	R <sub>ON</sub> Flatness <sup>(4)</sup>	V <sub>IN</sub> =0V-1.0V, I <sub>ON</sub> =-8mA	3.0		2.0		Ω
I <sub>CC</sub>	Quiescent Supply Current	V <sub>IN</sub> =0 or V <sub>CC</sub> , I <sub>OUT</sub> =0	3.6			1	μA
I <sub>CCT</sub>	Increase in I <sub>CC</sub> Current Per Control Voltage and V <sub>CC</sub>	V <sub>IN</sub> =2.6V V <sub>CC</sub> =3.6V	3.6			10	μA

### Notes:

- Measured by the voltage drop across the D<sub>n</sub>, D1<sub>n</sub>, D2<sub>n</sub> pins at the indicated current through the switch. On resistance is determined by the lower of the voltage on the two (HSD<sub>n</sub> or D<sub>n</sub> ports).
- Guaranteed by characterization.

## AC Electrical Characteristics

All typical values are for V<sub>CC</sub>=3.3V at 25°C unless otherwise specified.

Symbol	Parameter	Conditions	V <sub>CC</sub> (V)	T <sub>A</sub> =- 40°C to +85°C			Units
				Min.	Typ.	Max.	
t <sub>ON</sub>	Turn-On Time S, /OE to Output	V <sub>D1n</sub> , D2 <sub>n</sub> =0.8V, R <sub>L</sub> =50Ω, C <sub>L</sub> =10pF Figure 8	3.0 to 3.6		10	13	ns
t <sub>OFF</sub>	Turn-Off Time S, /OE to Output	V <sub>D1n</sub> , D2 <sub>n</sub> =0.8V, R <sub>L</sub> =50Ω, C <sub>L</sub> =10pF Figure 8	3.0 to 3.6		8	11	ns
t <sub>PD</sub>	Propagation Delay <sup>(6)</sup>	R <sub>L</sub> =50Ω, C <sub>L</sub> =10pF Figure 6, Figure 7	3.3		0.25		ns
O <sub>IRR</sub>	Off Isolation, Non-Adjacent	f=250MHz, R <sub>T</sub> =50Ω Figure 14	3.0 to 3.6		-30		dB
Xtalk	Non-Adjacent Channel Crosstalk	f=250MHz, R <sub>T</sub> =50Ω Figure 9	3.0 to 3.6		-43		dB
BW	-3db Bandwidth	R <sub>T</sub> =50Ω Figure 13	3.0 to 3.6		720		MHz

### Note:

- Guaranteed by characterization.

### USB Hi-Speed-Related AC Electrical Characteristics

Symbol	Parameter	Conditions	V <sub>CC</sub> (V)	T <sub>A</sub> =- 40°C to +85°C			Units
				Min.	Typ.	Max.	
t <sub>SK(O)</sub>	Channel-to-Channel Skew <sup>(7)</sup>	R <sub>L</sub> =50Ω, C <sub>L</sub> =10pF Figure 6, Figure 12	3.0 to 3.6		40		ps
t <sub>SK(P)</sub>	Skew of Opposite Transitions of the Same Output <sup>(7)</sup>	R <sub>L</sub> =50Ω, C <sub>L</sub> =10pF Figure 6, Figure 12	3.0 to 3.6		20		ps
t <sub>J</sub>	Total Jitter <sup>(7)</sup>	R <sub>L</sub> =50Ω, C <sub>L</sub> =10pf, t <sub>R</sub> =t <sub>F</sub> =750ps at 480Mbps (PRBS=2 <sup>15</sup> - 1)	3.0 to 3.6		150		ps

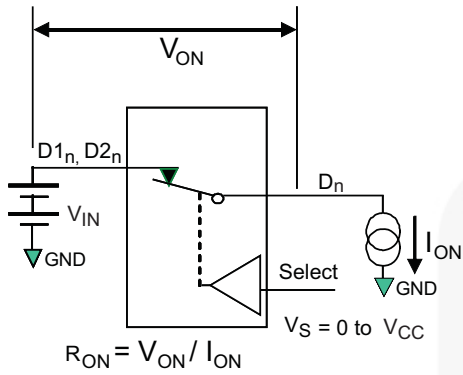
**Note:**

7. Guaranteed by characterization.

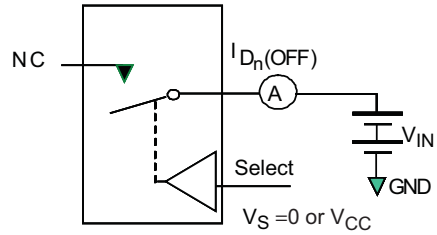
### Capacitance

Symbol	Parameter	Conditions	T <sub>A</sub> =- 40°C to +85°C			Units
			Min.	Typ.	Max.	
C <sub>IN</sub>	Control Pin Input Capacitance	V <sub>CC</sub> =0V Figure 11		2		pF
C <sub>ON</sub>	D1 <sub>n</sub> , D2 <sub>n</sub> , D <sub>n</sub> On Capacitance	V <sub>CC</sub> =3.3V, /OE=0V Figure 10		9		pF
C <sub>OFF</sub>	D1 <sub>n</sub> , D2 <sub>n</sub> Off Capacitance	V <sub>CC</sub> and /OE=3.3V Figure 11		4		pF

**Test Diagrams**

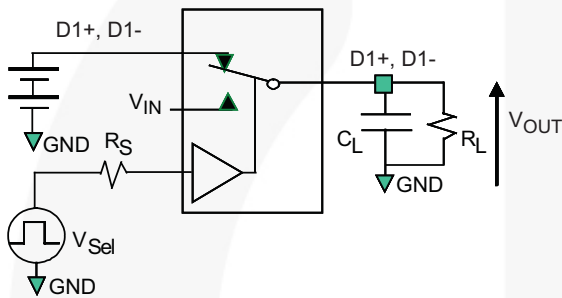


**Figure 4. On Resistance**



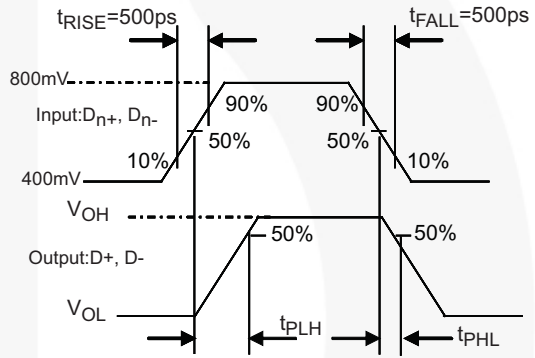
\*\*Each switch port is tested separately

**Figure 5. Off Leakage**

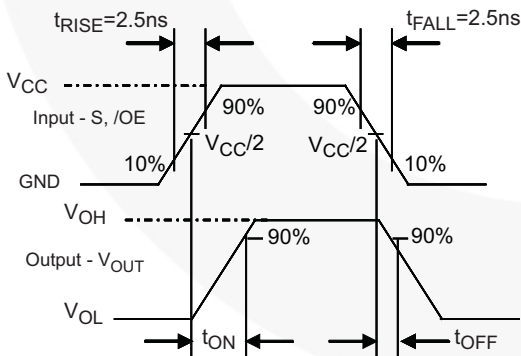


$R_L$ ,  $R_S$ , and  $C_L$  are functions of the application environment (see AC Tables for specific values)  
 $C_L$  includes test fixture and stray capacitance.

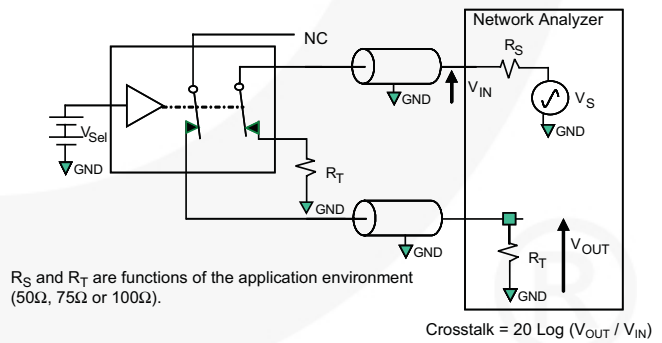
**Figure 6. AC Test Circuit Load**



**Figure 7. Switch Propagation Delay Waveforms**



**Figure 8. Turn On / Turn Off Waveform**

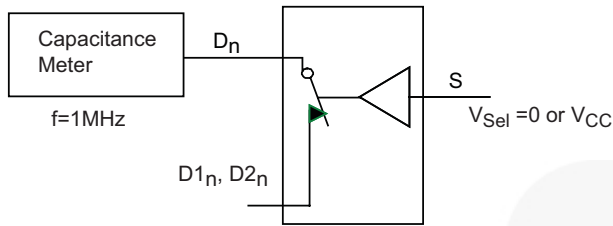


$R_S$  and  $R_T$  are functions of the application environment (50Ω, 75Ω or 100Ω).

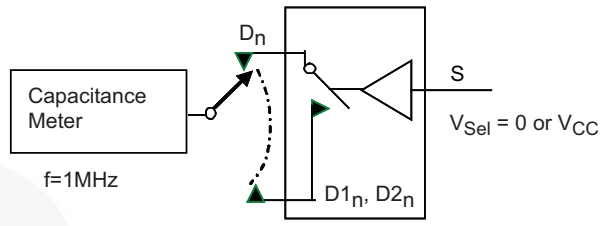
Crosstalk = 20 Log ( $V_{OUT} / V_{IN}$ )

**Figure 9. Non-Adjacent Channel-to-Channel Crosstalk**

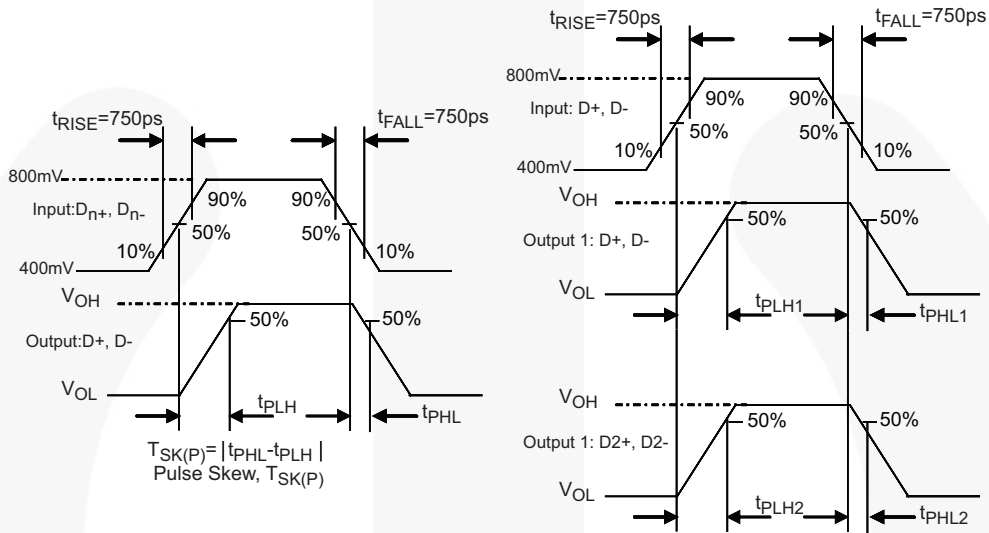
**Test Diagrams (Continued)**



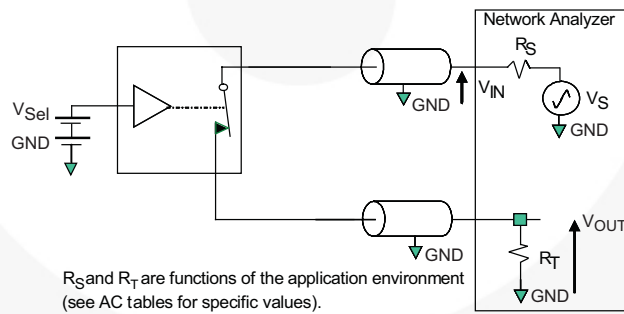
**Figure 10. Channel On Capacitance**



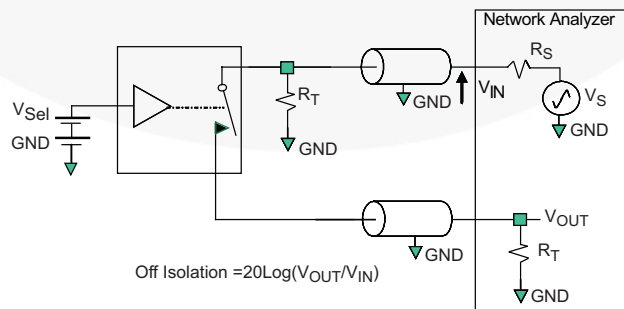
**Figure 11. Channel Off Capacitance**



**Figure 12. Switch Skew Tests**

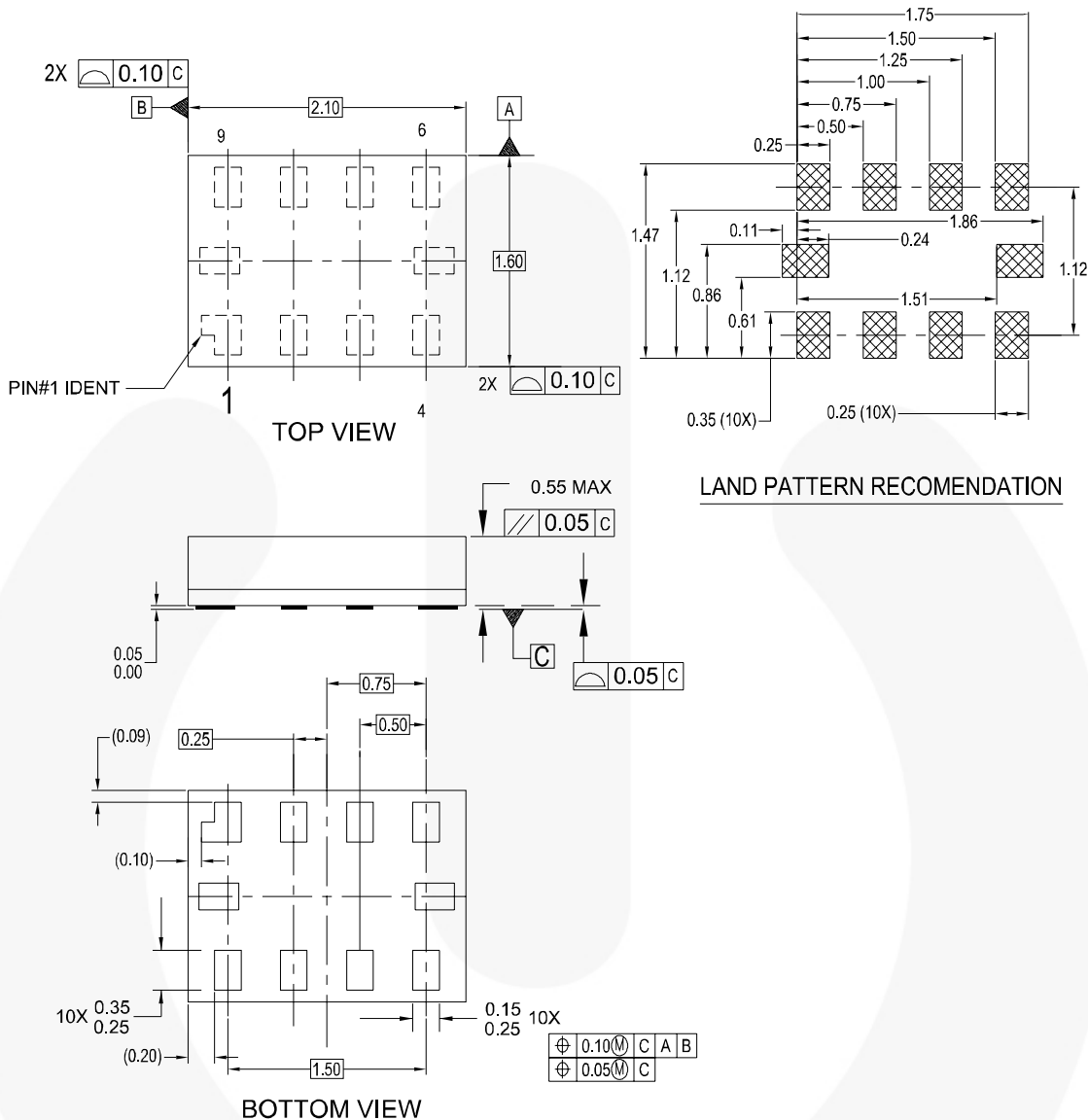


**Figure 13. Bandwidth**



**Figure 14. Channel Off Isolation**

## Physical Dimensions



### NOTES:

- A. PACKAGE CONFORMS TO JEDEC MO255, VARIATION UABD
- B. DIMENSIONS ARE IN MILLIMETERS.
- C. DIMENSIONS AND TOLERANCES CONFORMS TO ASME Y14.5M, 1994.

MAC010ARevC

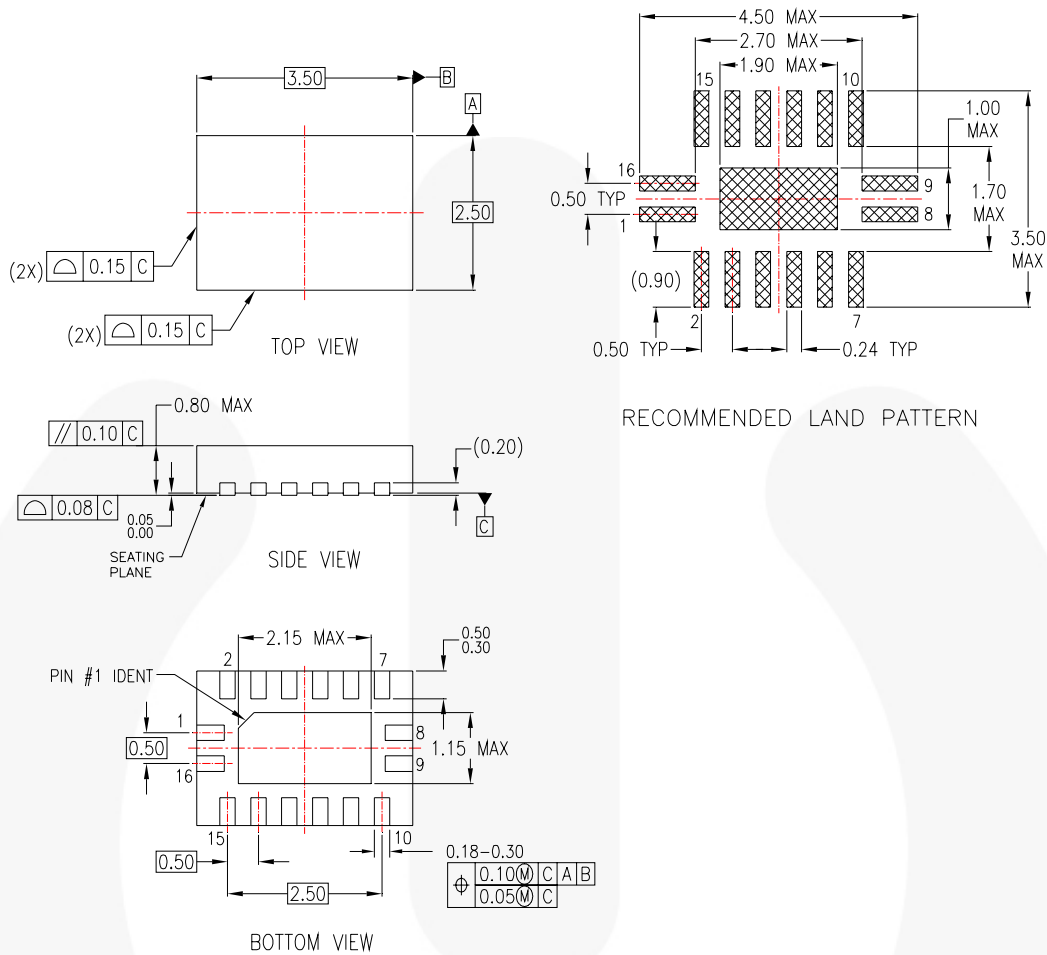
Figure 15. 10-Lead MicroPak™ 1.6 x 2.1mm

**Note:** [click here for tape and reel specifications, available at: http://www.fairchildsemi.com/products/analog/pdf//micropak\\_tr.pdf](http://www.fairchildsemi.com/products/analog/pdf//micropak_tr.pdf)

Package drawings are provided as a service to customers considering Fairchild components. Drawings may change in any manner without notice. Please note the revision and/or date on the drawing and contact a Fairchild Semiconductor representative to verify or obtain the most recent revision. Package specifications do not expand the terms of Fairchild's worldwide terms and conditions, specifically the warranty therein, which covers Fairchild products.

Always visit Fairchild Semiconductor's online packaging area for the most recent package drawings:  
<http://www.fairchildsemi.com/packaging/>

Physical Dimensions



NOTES:

- A. CONFORMS TO JEDEC REGISTRATION MO-241, VARIATION AB
- B. DIMENSIONS ARE IN MILLIMETERS.
- C. DIMENSIONS AND TOLERANCES PER ASME Y14.5M, 1994

MLP16ErevA

Figure 16. 16-Terminal Depopulated Quad Very-Thin Flat Pack No Leads (DQFN) Package

**Note:** [click here for tape and reel specifications, available at: http://www.fairchildsemi.com/products/analog/packaging/MLP16\\_25x35.html](http://www.fairchildsemi.com/products/analog/packaging/MLP16_25x35.html)

Package drawings are provided as a service to customers considering Fairchild components. Drawings may change in any manner without notice. Please note the revision and/or date on the drawing and contact a Fairchild Semiconductor representative to verify or obtain the most recent revision. Package specifications do not expand the terms of Fairchild's worldwide terms and conditions, specifically the warranty therein, which covers Fairchild products.

Always visit Fairchild Semiconductor's online packaging area for the most recent package drawings: <http://www.fairchildsemi.com/packaging/>



**TRADEMARKS**

The following includes registered and unregistered trademarks and service marks, owned by Fairchild Semiconductor and/or its global subsidiaries, and is not intended to be an exhaustive list of all such trademarks.

- |   |  |   |   |
|---|--|---|---|
| ACEX <sup>®</sup>   | FPST <sup>™</sup>                            | PDP SPM <sup>™</sup>  | The Power Franchise <sup>®</sup>  |
| Build it Now <sup>™</sup>   | F-PFS <sup>™</sup>                           | Power-SPM <sup>™</sup>  |  |
| CorePLUS <sup>™</sup>   | FRFET <sup>®</sup>                           | PowerTrench <sup>®</sup>  | TinyBoost <sup>™</sup>  |
| CorePOWER <sup>™</sup>  | Global Power Resource <sup>SM</sup>          | Programmable Active Droop <sup>™</sup>  | TinyBuck <sup>™</sup>   |
| CROSSVOLT <sup>™</sup>  | Green FPS <sup>™</sup>                       | QFET <sup>®</sup>   | TinyLogic <sup>®</sup>  |
| CTL <sup>™</sup>  | Green FPS <sup>™</sup> e-Series <sup>™</sup> | QST <sup>™</sup>  | TINYOPTO <sup>™</sup>   |
| Current Transfer Logic <sup>™</sup>   | GTO <sup>™</sup>                             | Quiet Series <sup>™</sup>   | TinyPower <sup>™</sup>  |
| EcoSPARK <sup>®</sup>   | IntelliMAX <sup>™</sup>                      | RapidConfigure <sup>™</sup>   | TinyPWM <sup>™</sup>  |
| EfficientMax <sup>™</sup>   | ISOPLANAR <sup>™</sup>                       | Saving our world, 1mW at a time <sup>™</sup>                                      | TinyWire <sup>™</sup>   |
| EZSWITCH <sup>™</sup> *   | MegaBuck <sup>™</sup>                        | SmartMax <sup>™</sup>   | μSerDes <sup>™</sup>  |
|  | MICROCOUPLER <sup>™</sup>                    | SMART START <sup>™</sup>  |  |
|  | MicroFET <sup>™</sup>                        | SPM <sup>®</sup>  | UHC <sup>®</sup>  |
| Fairchild <sup>®</sup>  | MicroPak <sup>™</sup>                        | STEALTH <sup>™</sup>  | Ultra FRFET <sup>™</sup>  |
| Fairchild Semiconductor <sup>®</sup>  | MillerDrive <sup>™</sup>                     | SuperFET <sup>™</sup>   | UniFET <sup>™</sup>   |
| FACT Quiet Series <sup>™</sup>  | MotionMax <sup>™</sup>                       | SuperSOT <sup>™</sup> -3  | V CX <sup>™</sup>   |
| FACT <sup>®</sup>   | Motion-SPM <sup>™</sup>                      | SuperSOT <sup>™</sup> -6  | VisualMax <sup>™</sup>  |
| FAST <sup>®</sup>   | OPTOLOGIC <sup>®</sup>                       | SuperSOT <sup>™</sup> -8  |   |
| FAST <sup>®</sup>   | OPTOPLANAR <sup>®</sup>                      | SupreMOS <sup>™</sup>   |   |
| FastvCore <sup>™</sup>  |  | SyncFET <sup>™</sup>  |   |
| FlashWriter <sup>®</sup> *  |  |  |   |

\* EZSWITCH<sup>™</sup> and FlashWriter<sup>®</sup> are trademarks of System General Corporation, used under license by Fairchild Semiconductor.

**DISCLAIMER**

FAIRCHILD SEMICONDUCTOR RESERVES THE RIGHT TO MAKE CHANGES WITHOUT FURTHER NOTICE TO ANY PRODUCTS HEREIN TO IMPROVE RELIABILITY, FUNCTION, OR DESIGN. FAIRCHILD DOES NOT ASSUME ANY LIABILITY ARISING OUT OF THE APPLICATION OR USE OF ANY PRODUCT OR CIRCUIT DESCRIBED HEREIN; NEITHER DOES IT CONVEY ANY LICENSE UNDER ITS PATENT RIGHTS, NOR THE RIGHTS OF OTHERS. THESE SPECIFICATIONS DO NOT EXPAND THE TERMS OF FAIRCHILD'S WORLDWIDE TERMS AND CONDITIONS, SPECIFICALLY THE WARRANTY THEREIN, WHICH COVERS THESE PRODUCTS.

**LIFE SUPPORT POLICY**

FAIRCHILD'S PRODUCTS ARE NOT AUTHORIZED FOR USE AS CRITICAL COMPONENTS IN LIFE SUPPORT DEVICES OR SYSTEMS WITHOUT THE EXPRESS WRITTEN APPROVAL OF FAIRCHILD SEMICONDUCTOR CORPORATION.

As used herein:

1. Life support devices or systems are devices or systems which, (a) are intended for surgical implant into the body or (b) support or sustain life, and (c) whose failure to perform when properly used in accordance with instructions for use provided in the labeling, can be reasonably expected to result in a significant injury of the user.
2. A critical component in any component of a life support, device, or system whose failure to perform can be reasonably expected to cause the failure of the life support device or system, or to affect its safety or effectiveness.

**PRODUCT STATUS DEFINITIONS**

**Definition of Terms**

Datasheet Identification	Product Status	Definition
Advance Information	Formative / In Design	This datasheet contains the design specifications for product development. Specifications may change in any manner without notice.
Preliminary	First Production	This datasheet contains preliminary data; supplementary data will be published at a later date. Fairchild Semiconductor reserves the right to make changes at any time without notice to improve design.
No Identification Needed	Full Production	This datasheet contains final specifications. Fairchild Semiconductor reserves the right to make changes at any time without notice to improve the design.
Obsolete	Not In Production	This datasheet contains specifications on a product that is discontinued by Fairchild Semiconductor. The datasheet is for reference information only.

Rev. I34