

# Test Procedure for the LV8411GREVB Evaluation Board



**SANYO Semiconductors**

An ON Semiconductor Company

## For Stepping Motor Control

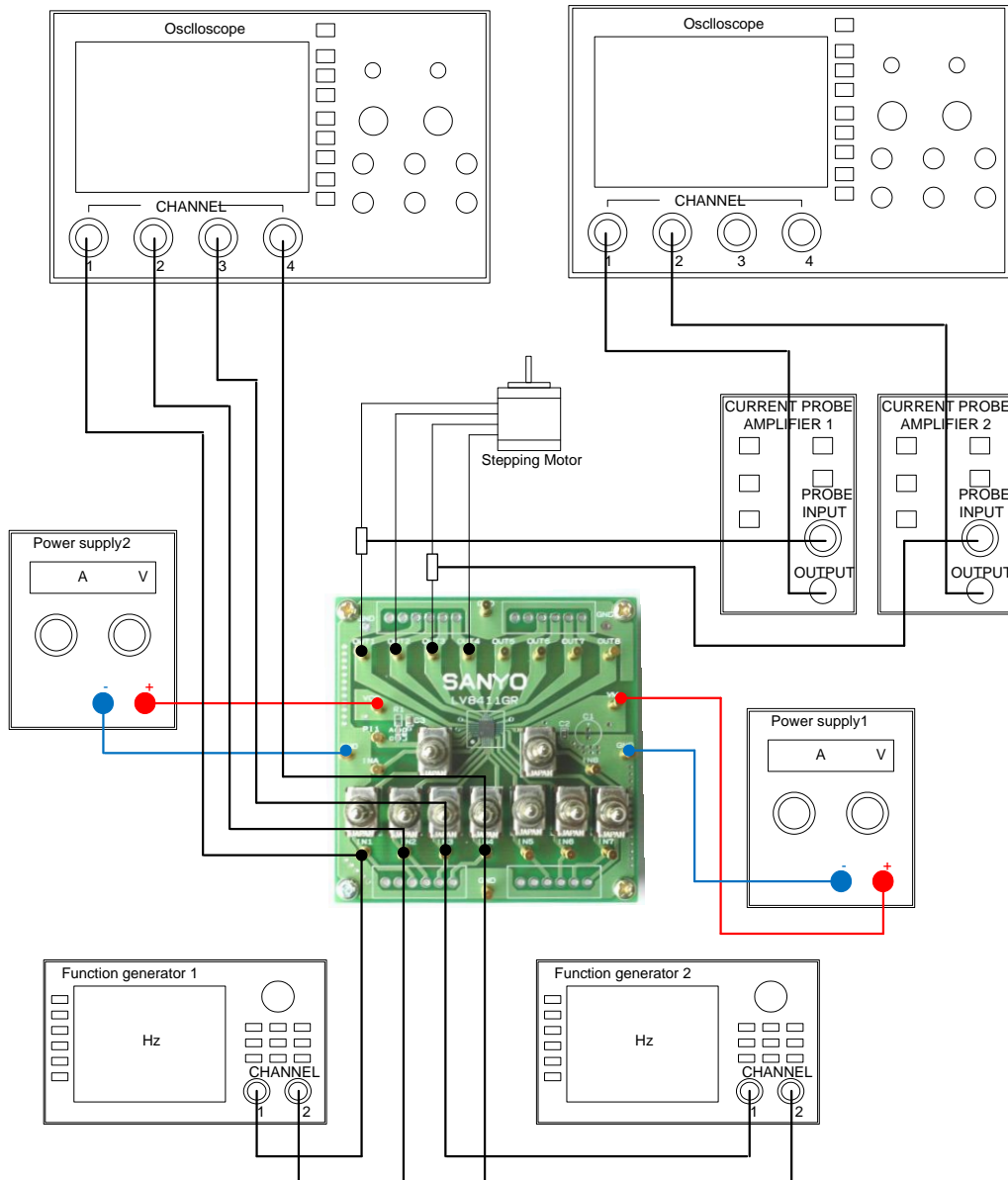

**Table1: Required Equipment**

Equipment	Efficiency
Power supply1	6V-1A
Power supply2	6V-0.5A
Function generator	200kHz × 2unit
Oscilloscope	4 channel × 2unit
Current probe	2unit
LV8411GR Evaluation Board	-
Stepping Motor	6V-0.5A

**Test Procedure:**

1. Connect the test setup as shown above.
2. Set it according to the following specifications:

**Supply Voltage:**

- VM (2.7 to 5.5V): Power Supply for LSI
- VCC (2.7 to 5.5V): Logic “High” voltage for toggle switch

**Toggle Switch State:**

- Upper Side: High (VCC)
- Middle: Open, enable to external logic input
- Lower Side: Low (GND)

**Operation Guide** - You can drive stepping motor through 1-2 phase excitation mode by switching input signal as follows. In the case of stepping motor 2, switch IN5 to IN8 in the same way.

**Table2: Truth table**

INPUT				OUTPUT				Position No.
IN1	IN2	IN3	IN4	OUT1	OUT2	OUT3	OUT4	
H	L	L	H	H	L	L	H	(1)
H	L	L	L	H	L	OFF	OFF	(2)
H	L	H	L	H	L	H	L	(3)
L	L	H	L	OFF	OFF	H	L	(4)
L	H	H	L	L	H	H	L	(5)
L	H	L	L	L	H	OFF	OFF	(6)
L	H	L	H	L	H	L	H	(7)
L	L	L	H	OFF	OFF	L	H	(8)

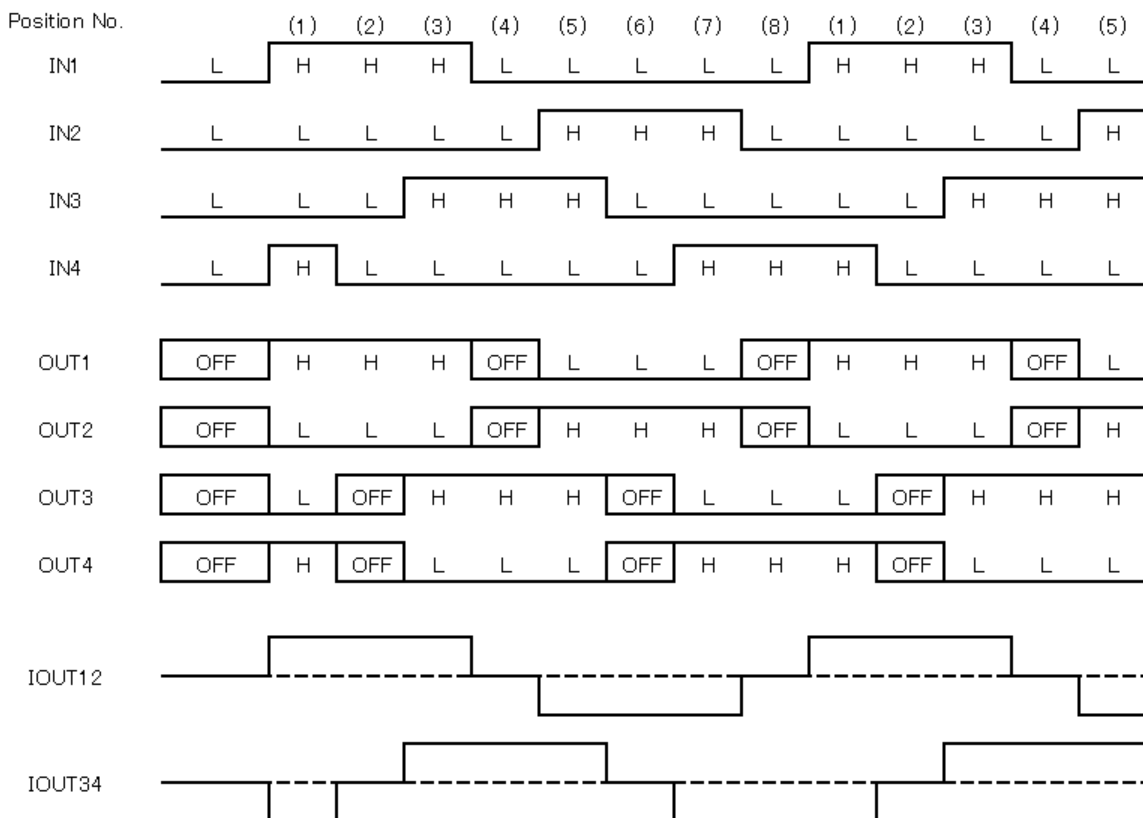

- Check the IN1, IN2, IN3, and IN4 terminal voltage at scope CH1 and CH2, and the output current waveform at scope CH3.

**Table3: Desired Results**

INPUT	OUTPUT
VM=5.0V VCC=5.0V IN1, IN2, IN3, and IN4 are switched every time of 1msec.	The output current and rotation of the stepping motor is confirmed.

