

MC14060B

14-Bit Binary Counter and Oscillator

The MC14060B is a 14-stage binary ripple counter with an on-chip oscillator buffer. The oscillator configuration allows design of either RC or crystal oscillator circuits. Also included on the chip is a reset function which places all outputs into the zero state and disables the oscillator. A negative transition on Clock will advance the counter to the next state. Schmitt trigger action on the input line permits very slow input rise and fall times. Applications include time delay circuits, counter controls, and frequency dividing circuits.

This device contains protection circuitry to guard against damage due to high static voltages or electric fields. However, precautions must be taken to avoid applications of any voltage higher than maximum rated voltages to this high-impedance circuit. For proper operation, V_{in} and V_{out} should be constrained to the range $V_{SS} \leq (V_{in} \text{ or } V_{out}) \leq V_{DD}$.

Unused inputs must always be tied to an appropriate logic voltage level (e.g., either V_{SS} or V_{DD}). Unused outputs must be left open.

- Fully Static Operation
- Diode Protection on All Inputs
- Supply Voltage Range = 3.0 V to 18 V
- Capable of Driving Two Low-power TTL Loads or One Low-power Schottky TTL Load Over the Rated Temperature Range
- Buffered Outputs Available from Stages 4 Through 10 and 12 Through 14
- Common Reset Line
- Pin-for-Pin Replacement for CD4060B
- Pb-Free Packages are Available*

MAXIMUM RATINGS (Voltages Referenced to V_{SS})

Symbol	Parameter	Value	Unit
V_{DD}	DC Supply Voltage Range	-0.5 to +18.0	V
V_{in} , V_{out}	Input or Output Voltage Range (DC or Transient)	-0.5 to V_{DD} +0.5	V
I_{in} , I_{out}	Input or Output Current (DC or Transient) per Pin	± 10	mA
P_D	Power Dissipation, per Package (Note 1)	500	mW
T_A	Ambient Temperature Range	-55 to +125	$^{\circ}\text{C}$
T_{stg}	Storage Temperature Range	-65 to +150	$^{\circ}\text{C}$
T_L	Lead Temperature (8 Second Soldering)	260	$^{\circ}\text{C}$

Maximum ratings are those values beyond which device damage can occur. Maximum ratings applied to the device are individual stress limit values (not normal operating conditions) and are not valid simultaneously. If these limits are exceeded, device functional operation is not implied, damage may occur and reliability may be affected.

1. Temperature Derating: Plastic "P and D/DW" Packages: -7.0 mW/ $^{\circ}\text{C}$ from 65 $^{\circ}\text{C}$ To 125 $^{\circ}\text{C}$.

*For additional information on our Pb-Free strategy and soldering details, please download the ON Semiconductor Soldering and Mounting Techniques Reference Manual, SOLDERRM/D.



ON Semiconductor®

MARKING DIAGRAMS

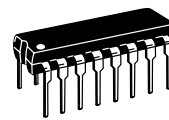

PDP-16
P SUFFIX
CASE 648

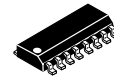
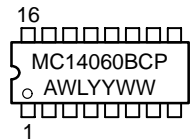

SOIC-16
D SUFFIX
CASE 751B

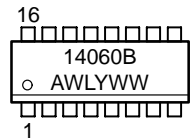

TSSOP-16
DT SUFFIX
CASE 948F

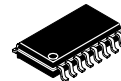
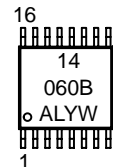

SOEIAJ-16
F SUFFIX
CASE 966

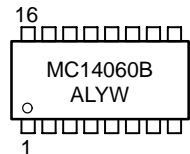

A = Assembly Location
WL, L = Wafer Lot
YY, Y = Year
WW, W = Work Week

ORDERING INFORMATION

See detailed ordering and shipping information in the package dimensions section on page 6 of this data sheet.

MC14060B

ELECTRICAL CHARACTERISTICS (Voltages Referenced to V_{SS})

Symbol	Characteristic	V _{DD} Vdc	- 55°C		25°C			125°C		Unit
			Min	Max	Min	Typ (Note 2)	Max	Min	Max	
V _{OL}	Output Voltage V _{in} = V _{DD} or 0 "0" Level	5.0	–	0.05	–	0	0.05	–	0.05	V
		10	–	0.05	–	0	0.05	–	0.05	
		15	–	0.05	–	0	0.05	–	0.05	
V _{OH}	V _{in} = 0 or V _{DD} "1" Level	5.0	4.95	–	4.95	5.0	–	4.95	–	V
		10	9.95	–	9.95	10	–	9.95	–	
		15	14.95	–	14.95	15	–	14.95	–	
V _{IL}	Input Voltage (V _O = 4.5 or 0.5 V) (V _O = 9.0 or 1.0 V) (V _O = 13.5 or 1.5 V) "0" Level	5.0	–	1.5	–	2.25	1.5	–	1.5	V
		10	–	3.0	–	4.50	3.0	–	3.0	
		15	–	4.0	–	6.75	4.0	–	4.0	
V _{IH}	(V _O = 0.5 or 4.5 V) (V _O = 1.0 or 9.0 V) (V _O = 1.5 or 13.5 V) "1" Level	5.0	3.5	–	3.5	2.75	–	3.5	–	V
		10	7.0	–	7.0	5.50	–	7.0	–	
		15	11.0	–	11.0	8.25	–	11.0	–	
V _{IL}	Input Voltage (V _O = 4.5 Vdc) (V _O = 9.0 Vdc) (V _O = 13.5 Vdc) "0" Level (For Input 11 and Output 10)	5.0	–	1.0	–	2.25	1.0	–	1.0	Vdc
		10	–	2.0	–	4.50	2.0	–	2.0	
		15	–	2.5	–	6.75	2.5	–	2.5	
V _{IH}	(V _O = 0.5 Vdc) (V _O = 1.0 Vdc) (V _O = 1.5 Vdc) "1" Level	5.0	4.0	–	4.0	2.75	–	4.0	–	Vdc
		10	8.0	–	8.0	5.50	–	8.0	–	
		15	12.5	–	12.5	8.25	–	12.5	–	
I _{OH}	Output Drive Current (V _{OH} = 2.5 V) (V _{OH} = 4.6 V) (V _{OH} = 9.5 V) (V _{OH} = 13.5 V) (Except Source Pins 9 and 10)	5.0	–3.0	–	–2.4	–4.2	–	–1.7	–	mA
		5.0	–0.64	–	–0.51	–0.88	–	–0.36	–	
		10	–1.6	–	–1.3	–2.25	–	–0.9	–	
		15	–4.2	–	–3.4	–8.8	–	–2.4	–	
I _{OL}	(V _{OL} = 0.4 V) (V _{OL} = 0.5 V) (V _{OL} = 1.5 V) Sink	5.0	0.64	–	0.51	0.88	–	0.36	–	mA
		10	1.6	–	1.3	2.25	–	0.9	–	
		15	4.2	–	3.4	8.8	–	2.4	–	
I _{in}	Input Current	15	–	±0.1	–	±0.00001	±0.1	–	±1.0	μA
C _{in}	Input Capacitance (V _{in} = 0)	–	–	–	–	5.0	7.5	–	–	pF
I _{DD}	Quiescent Current (Per Package)	5.0	–	5.0	–	0.005	5.0	–	150	μA
		10	–	10	–	0.010	10	–	300	
		15	–	20	–	0.015	20	–	600	
I _T	Total Supply Current (Notes 3, 4) (Dynamic plus Quiescent, Per Package) (C _L = 50 pF on all outputs, all buffers switching)	5.0 10 15	I _T = (0.25 μA/kHz) f + I _{DD} I _T = (0.54 μA/kHz) f + I _{DD} I _T = (0.85 μA/kHz) f + I _{DD}							μA

2. Data labelled "Typ" is not to be used for design purposes but is intended as an indication of the IC's potential performance.
3. The formulas given are for the typical characteristics only at 25°C.
4. To calculate total supply current at loads other than 50 pF: I_T(C_L) = I_T(50 pF) + (C_L – 50) Vfk
where: I_T is in μA (per package), C_L in pF, V = (V_{DD} – V_{SS}) in volts, f in kHz is input frequency, and k = 0.002.

MC14060B

SWITCHING CHARACTERISTICS (C_L = 50 pF, T_A = 25°C)

Symbol	Characteristic	V _{DD} Vdc	Min	Typ (Note 5)	Max	Unit	
t _{TLH}	Output Rise Time (Counter Outputs)	5.0	–	40	200	ns	
		10	–	25	100		
		15	–	20	80		
t _{THL}	Output Fall Time (Counter Outputs)	5.0	–	50	200	ns	
		10	–	30	100		
		15	–	20	80		
t _{PLH} t _{PHL}	Propagation Delay Time Clock to Q4 Clock to Q14	5.0	–	415	740	ns	
		10	–	175	300		
		15	–	125	200		
		5.0	–	1.5	2.7		μs
		10	–	0.7	1.3		
		15	–	0.4	1.0		
t _{wH}	Clock Pulse Width	5.0	100	65	–	ns	
		10	40	30	–		
		15	30	20	–		
f _φ	Clock Pulse Frequency	5.0	–	5	3.5	MHz	
		10	–	14	8		
		15	–	17	12		
t _{TLH} t _{THL}	Clock Rise and Fall Time	5.0	No Limit			ns	
		10					
		15					
t _w	Reset Pulse Width	5.0	120	40	–	ns	
		10	60	15	–		
		15	40	10	–		
t _{PHL}	Propagation Delay Time Reset to On	5.0	–	170	350	ns	
		10	–	80	160		
		15	–	60	100		

5. Data labelled "Typ" is not to be used for design purposes but is intended as an indication of the IC's potential performance.

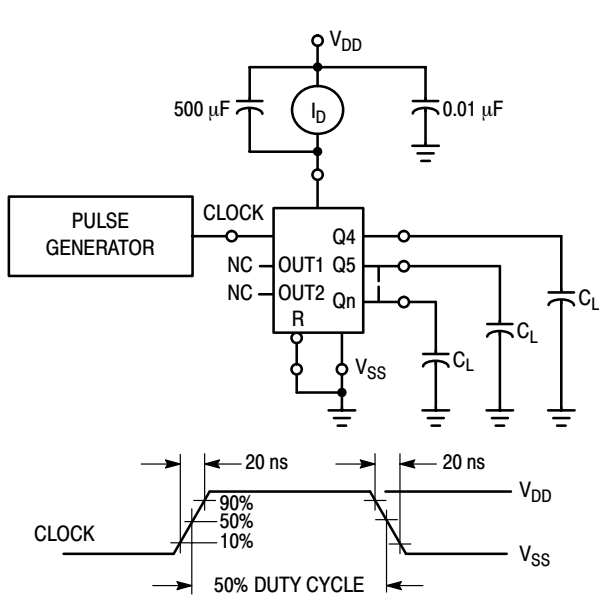

Figure 1. Power Dissipation Test Circuit and Waveform

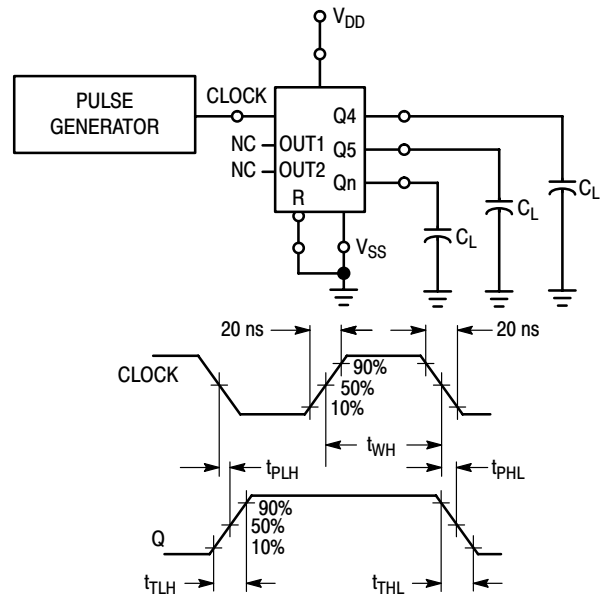

Figure 2. Switching Time Test Circuit and Waveforms

MC14060B

ORDERING INFORMATION

Device	Package	Shipping†
MC14060BCP	PDIP-16	500 Units / Rail
MC14060BCPG	PDIP-16 (Pb-Free)	500 Units / Rail
MC14060BD	SOIC-16	48 Units / Rail
MC14060BDR2	SOIC-16	2500 / Tape & Reel
MC14060BDR2G	SOIC-16 (Pb-Free)	2500 / Tape & Reel
MC14060BFEL	SOEIAJ-16 (Pb-Free)	2000 / Tape & Reel
MC14060BDTR2	TSSOP-16 (Pb-Free)	2500 / Tape & Reel

†For information on tape and reel specifications, including part orientation and tape sizes, please refer to our Tape and Reel Packaging Specifications Brochure, BRD8011/D.

MC14060B

PACKAGE DIMENSIONS

PDIP-16 P SUFFIX CASE 648-08 ISSUE T

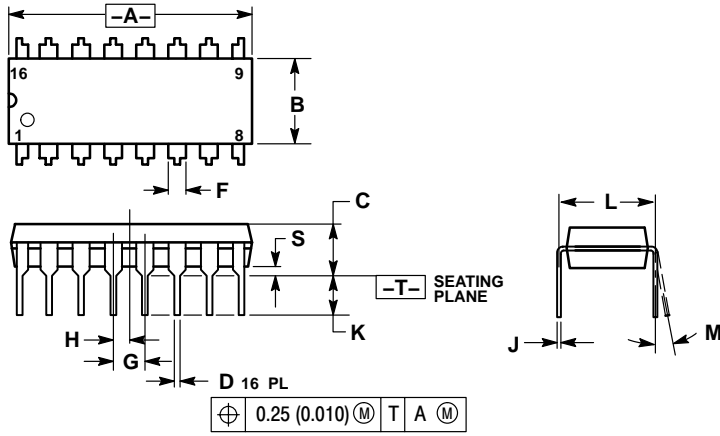

NOTES:

1. DIMENSIONING AND TOLERANCING PER ANSI Y14.5M, 1982.
2. CONTROLLING DIMENSION: INCH.
3. DIMENSION L TO CENTER OF LEADS WHEN FORMED PARALLEL.
4. DIMENSION B DOES NOT INCLUDE MOLD FLASH.
5. ROUNDED CORNERS OPTIONAL.

DIM	INCHES		MILLIMETERS	
	MIN	MAX	MIN	MAX
A	0.740	0.770	18.80	19.55
B	0.250	0.270	6.35	6.85
C	0.145	0.175	3.69	4.44
D	0.015	0.021	0.39	0.53
F	0.040	0.70	1.02	1.77
G	0.100 BSC		2.54 BSC	
H	0.050 BSC		1.27 BSC	
J	0.008	0.015	0.21	0.38
K	0.110	0.130	2.80	3.30
L	0.295	0.305	7.50	7.74
M	0°	10°	0°	10°
S	0.020	0.040	0.51	1.01

SOIC-16 D SUFFIX PLASTIC SOIC PACKAGE CASE 751B-05 ISSUE J

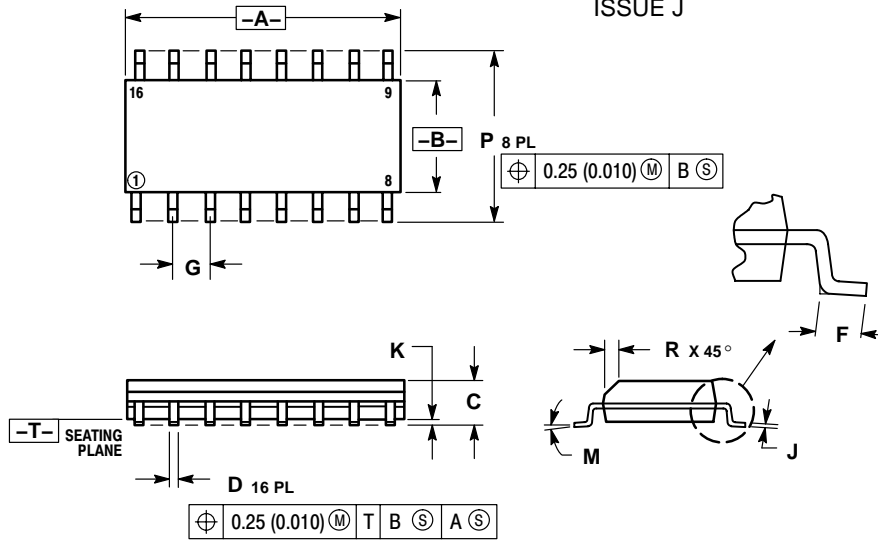

NOTES:

1. DIMENSIONING AND TOLERANCING PER ANSI Y14.5M, 1982.
2. CONTROLLING DIMENSION: MILLIMETER.
3. DIMENSIONS A AND B DO NOT INCLUDE MOLD PROTRUSION.
4. MAXIMUM MOLD PROTRUSION 0.15 (0.006) PER SIDE.
5. DIMENSION D DOES NOT INCLUDE DAMBAR PROTRUSION. ALLOWABLE DAMBAR PROTRUSION SHALL BE 0.127 (0.005) TOTAL IN EXCESS OF THE D DIMENSION AT MAXIMUM MATERIAL CONDITION.

DIM	MILLIMETERS		INCHES	
	MIN	MAX	MIN	MAX
A	9.80	10.00	0.386	0.393
B	3.80	4.00	0.150	0.157
C	1.35	1.75	0.054	0.068
D	0.35	0.49	0.014	0.019
F	0.40	1.25	0.016	0.049
G	1.27 BSC		0.050 BSC	
J	0.19	0.25	0.008	0.009
K	0.10	0.25	0.004	0.009
M	0°	7°	0°	7°
P	5.80	6.20	0.229	0.244
R	0.25	0.50	0.010	0.019