

MC74AC05, MC74ACT05

Hex Inverter with Open-Drain Outputs

The MC74AC/ACT05 is identical in pinout to the LS05. The device inputs are compatible with standard CMOS inputs; with pullup resistors, they are compatible with TTL outputs.

- Outputs Source/Sink 24 mA
- 'ACT05 Has TTL Compatible Inputs

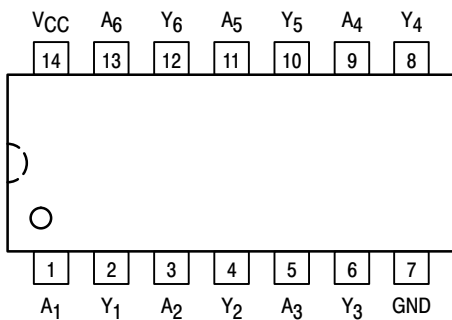

Figure 1. Pinout: 14-Lead Packages (Top View)

FUNCTION TABLE

Input A	Output Y
L	Z
H	L

NOTE: Z = High Impedance

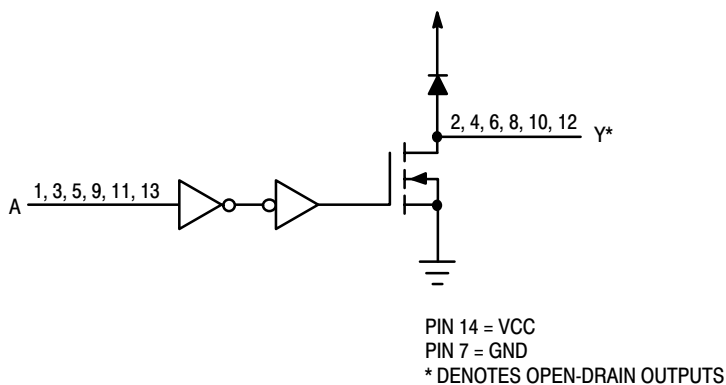
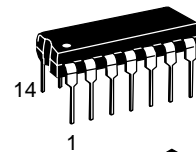

Figure 2. Logic Diagram



ON Semiconductor™

<http://onsemi.com>



PDIP-14
N SUFFIX
CASE 646

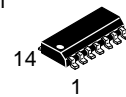

SO-14
D SUFFIX
CASE 751A

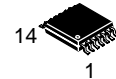

TSSOP-14
DT SUFFIX
CASE 948G

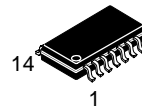

EIAJ-14
M SUFFIX
CASE 965

ORDERING INFORMATION

Device	Package	Shipping
MC74AC05N	PDIP-14	25 Units/Rail
MC74ACT05N	PDIP-14	25 Units/Rail
MC74AC05D	SOIC-14	55 Units/Rail
MC74AC05DR2	SOIC-14	2500 Tape & Reel
MC74ACT05D	SOIC-14	55 Units/Rail
MC74ACT05DR2	SOIC-14	2500 Tape & Reel
MC74AC05DT	TSSOP-14	96 Units/Rail
MC74AC05DTR2	TSSOP-14	2500 Tape & Reel
MC74ACT05DT	TSSOP-14	96 Units/Rail
MC74ACT05DTR2	TSSOP-14	2500 Tape & Reel
MC74AC05M	EIAJ-14	50 Units/Rail
MC74AC05MEL	EIAJ-14	2000 Tape & Reel
MC74ACT05M	EIAJ-14	50 Units/Rail
MC74ACT05MEL	EIAJ-14	2000 Tape & Reel

DEVICE MARKING INFORMATION

See general marking information in the device marking section on page 5 of this data sheet.

MC74AC05, MC74ACT05

MAXIMUM RATINGS*

Symbol	Parameter	Value	Unit
V_{CC}	DC Supply Voltage (Referenced to GND)	-0.5 to +7.0	V
V_{in}	DC Input Voltage (Referenced to GND)	-0.5 to $V_{CC} + 0.5$	V
V_{out}	DC Output Voltage (Referenced to GND)	-0.5 to $V_{CC} + 0.5$	V
I_{in}	DC Input Current, per Pin	± 20	mA
I_{out}	DC Output Sink/Source Current, per Pin	± 50	mA
I_{CC}	DC V_{CC} or GND Current per Output Pin	± 50	mA
T_{stg}	Storage Temperature	-65 to +150	$^{\circ}\text{C}$

*Maximum Ratings are those values beyond which damage to the device may occur. Functional operation should be restricted to the Recommended Operating Conditions.

RECOMMENDED OPERATING CONDITIONS

Symbol	Parameter	Min	Typ	Max	Unit
V_{CC}	Supply Voltage	'AC	2.0	6.0	V
		'ACT	4.5	5.5	
VREG	DC Regulated Power Voltage (Ref. to GND)	0	-	V_{CC}	V
t_r, t_f	Input Rise and Fall Time (Note 1) 'AC Devices except Schmitt Inputs	$V_{CC} @ 3.0\text{ V}$	-	150	ns/V
		$V_{CC} @ 4.5\text{ V}$	-	40	
		$V_{CC} @ 5.5\text{ V}$	-	25	
t_r, t_f	Input Rise and Fall Time (Note 2) 'ACT Devices except Schmitt Inputs	$V_{CC} @ 4.5\text{ V}$	-	10	ns/V
		$V_{CC} @ 5.5\text{ V}$	-	8.0	
T_J	Junction Temperature (PDIP)	-	-	140	$^{\circ}\text{C}$
T_A	Operating Ambient Temperature Range	-40	25	85	$^{\circ}\text{C}$
I_{OH}	Output Current – HIGH	-	-	-24	mA
I_{OL}	Output Current – LOW	-	-	24	mA

- V_{in} from 30% to 70% V_{CC} ; see individual Data Sheets for devices that differ from the typical input rise and fall times.
- V_{in} from 0.8 V to 2.0 V; see individual Data Sheets for devices that differ from the typical input rise and fall times.