

# NV8664ST50T3GEVB

## NCV8664 Evaluation Board User's Manual



ON Semiconductor®

<http://onsemi.com>

### EVAL BOARD USER'S MANUAL

#### Description

The NCV8664 is a precision 3.3 V and 5.0 V fixed output, low dropout integrated voltage regulator with an output current capability of 150 mA. Careful management of light load current consumption, combined with a low leakage process, achieve a typical quiescent ground current of 22  $\mu$ A. The output voltage is accurate within  $\pm 2.0\%$ , and maximum dropout voltage is 600 mV at full rated load current. The following ceramic capacitors are the recommended values to be used with these devices;  $C_{in} = 0.1 \mu$ F,  $C_{out} = 10 \mu$ F.

#### Features

- $\pm 2.0\%$  Output Accuracy, Over Full Temperature Range
- 30  $\mu$ A Maximum Quiescent Current at  $I_{out} = 100 \mu$ A
- 600 mV Maximum Dropout Voltage at 150 mA Load Current

- Wide Input Voltage Operating Range of 5.5 V to 45 V
- Internal Fault Protection
  - -42 V Reverse Voltage
  - Short Circuit/Overcurrent
  - Thermal Overload

#### Board Notes

Max voltage on  $V_{in}$  cap not to exceed 35 V.

#### Board Layouts

These boards are shown in sets of 2 due to the minimum board size requirement of most board fabrication houses. When sent out for fabrication, it must be indicated that the center line of the board set be V-scored to allow board separation.

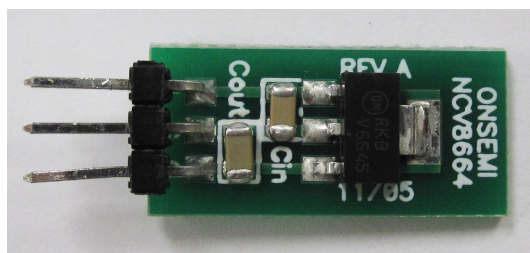

Figure 1. Evaluation Board Photo

# NV8664ST50T3GEVB

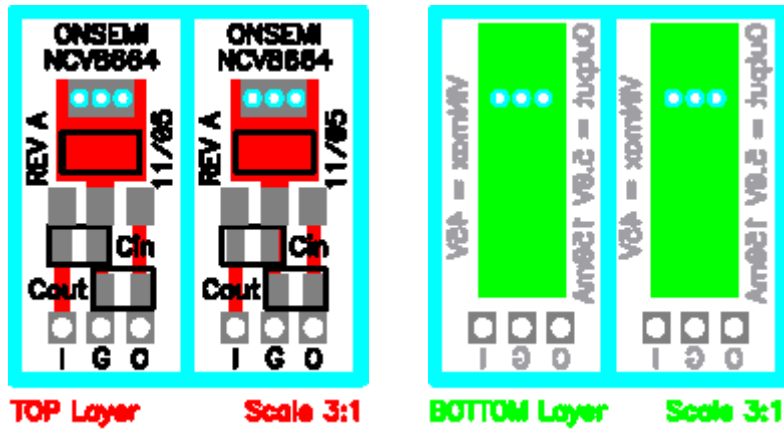

Figure 2. SOT-223 Evaluation Board

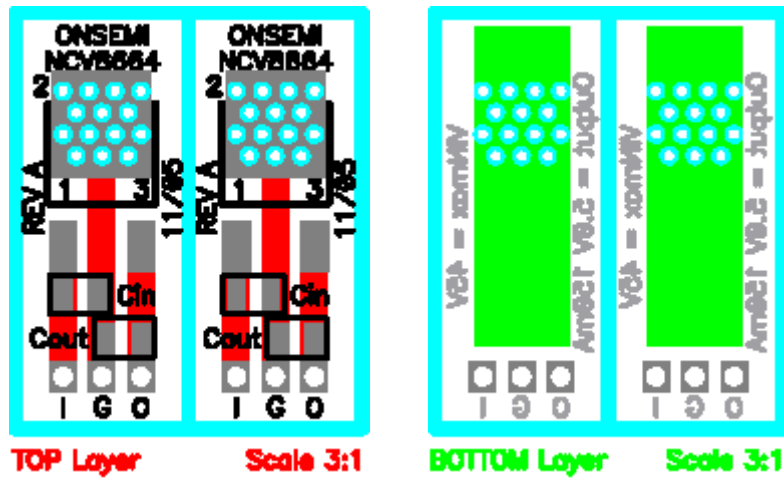

Figure 3. DPAK Evaluation Board

## SCHEMATIC FOR THE NCV8664 EVALUATION BOARD

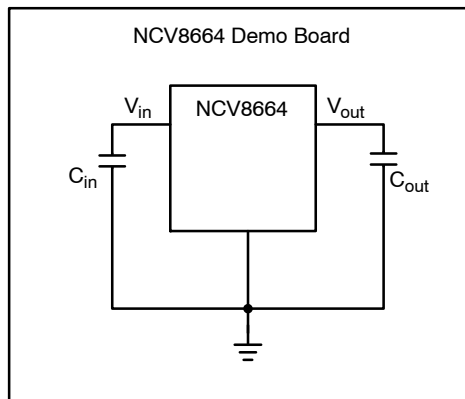

Figure 4. NCV8664 Evaluation Board Circuit

# NV8664ST50T3GEVB

**Table 1. BILL OF MATERIALS FOR THE NCV8664 EVALUATION BOARD**

Value	Tolerance	Footprint	Manufacturer	Part Number	Substitution Allowed	Lead Free
-------	-----------	-----------	--------------	-------------	----------------------	-----------

**SOT223 BOM**

-	-	-	Advanced Circuits	NCV8664DPAK3DemoBoard	No	Yes
-	-	SOT223	On Semiconductor	NCV8664ST50R3G	No	Yes
-	-	-	Molex/Waldom Electronics Corporation	22-28-8030	Yes	Yes
0.1 $\mu$ F	10%	1206	Murata Electronics North America	GRM319R71H104KA01D	Yes	Yes
10 $\mu$ F	10%	1206	Murata Electronics North America	GRM31CR71C106KAC7L	Yes	Yes

**DPAK BOM**

-	-	-	Advanced Circuits	NCV8664DPAK3DemoBoard	No	Yes
-	-	DPAK	On Semiconductor	NCV8664DT50RKG	No	Yes
-	-	-	Molex/Waldom Electronics Corporation	22-28-8030	Yes	Yes
0.1 $\mu$ F	10%	1206	Murata Electronics North America	GRM319R71H104KA01D	Yes	Yes
10 $\mu$ F	10%	1206	Murata Electronics North America	GRM31CR71C106KAC7L	Yes	Yes

**Test Procedure**

Required Equipment:

- Resistive Load
- 2 Multimeters
- One NCV8664 Evaluation Board
- DC Power Supply

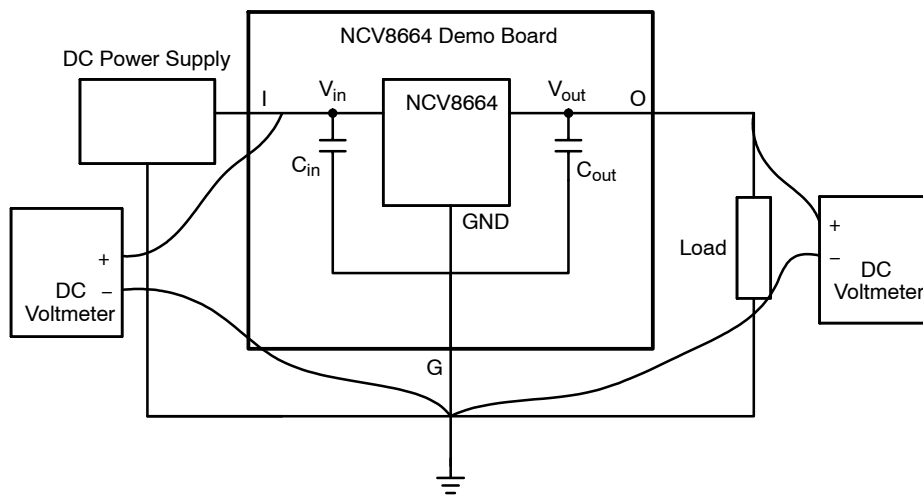

**Figure 5. Dropout Voltage Test Setup**

**Dropout Voltage Verification Steps**

1. Connect circuit as shown in Figure 5.
2. Set  $V_{in} = 13.5$  V, Record  $V_{out}$ .
3. Reduce  $V_{in}$  until  $V_{out}$  has dropped by 100 mV.
4. Subtract  $V_{out}$  from  $V_{in}$ . Resulting Voltage is Dropout Voltage.

## NV8664ST50T3GEVB

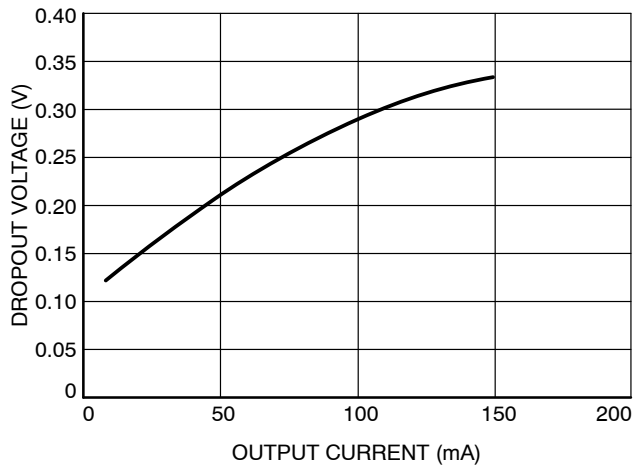

Figure 6. Dropout Voltage vs. Output Current

### Quiescent Current Verification Steps

1. Connect circuit as shown in Figure 7.
2. Set  $V_{in} = 13.5$  V.
3. Subtract Output Current from Input Current.

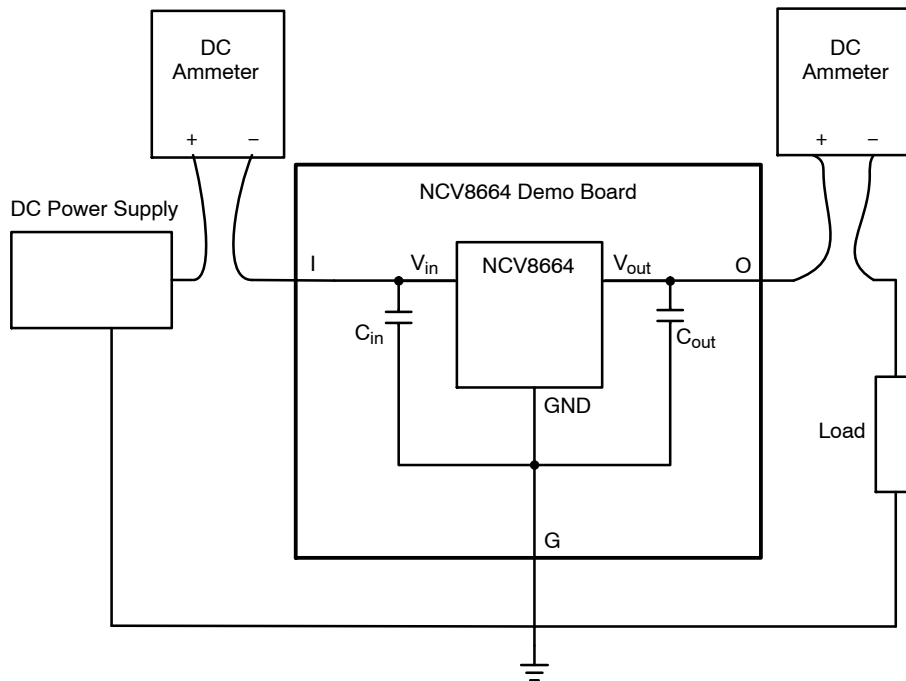
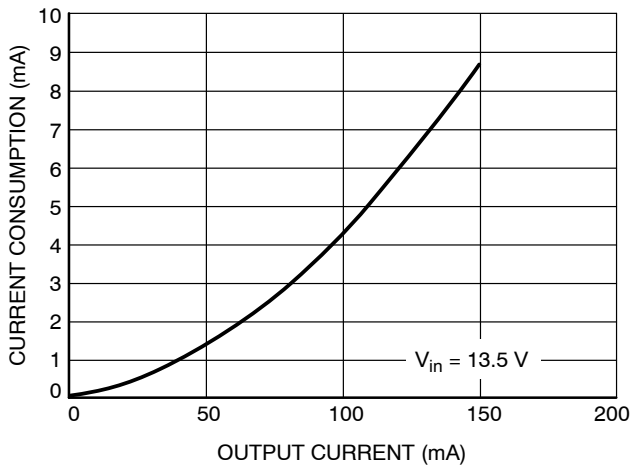

Figure 7. Quiescent Current Verification Setup

# NV8664ST50T3GEVB



**Figure 8. Current Consumption vs. Output Current**

## Output Voltage Verification Steps

1. Connect circuit as shown in Figure 9.
2. Set output load to  $100\ \Omega$ , Set  $V_{in} = 0\ \text{V}$ , Record  $V_{out}$ .
3. Increase  $V_{in}$ , measure  $V_{out}$ .

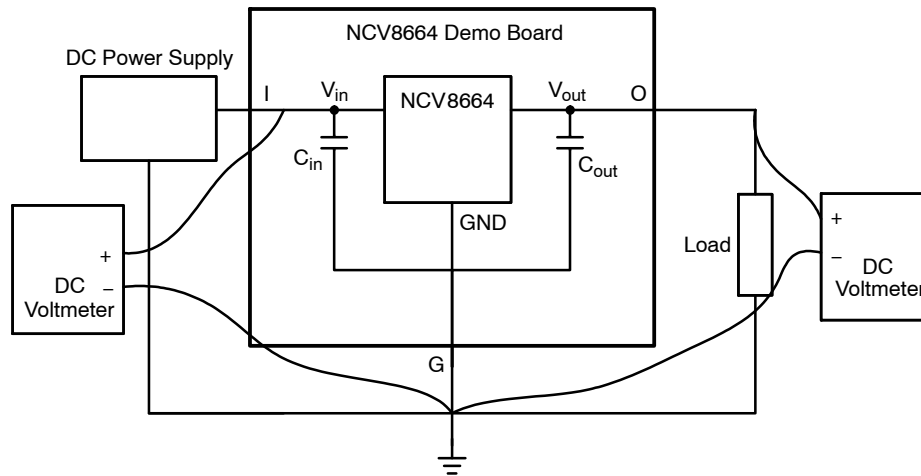

**Figure 9. Quiescent Current Verification Setup**

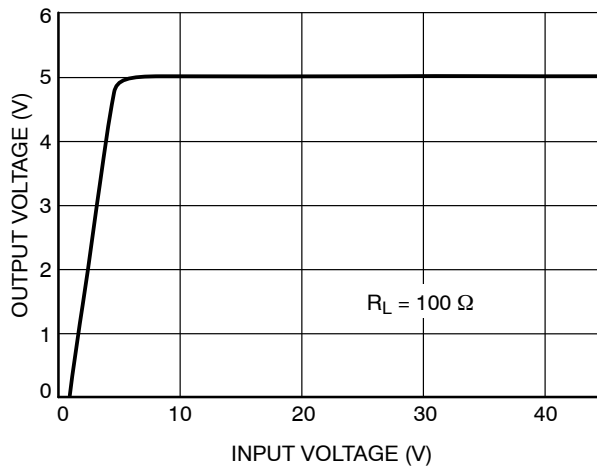

**Figure 10. Input Voltage vs. Output Voltage**

ON Semiconductor and the ON Semiconductor logo are trademarks of Semiconductor Components Industries, LLC dba ON Semiconductor or its subsidiaries in the United States and/or other countries. ON Semiconductor owns the rights to a number of patents, trademarks, copyrights, trade secrets, and other intellectual property. A listing of ON Semiconductor's product/patent coverage may be accessed at [www.onsemi.com/site/pdf/Patent-Marking.pdf](http://www.onsemi.com/site/pdf/Patent-Marking.pdf). ON Semiconductor is an Equal Opportunity/Affirmative Action Employer. This literature is subject to all applicable copyright laws and is not for resale in any manner.

The evaluation board/kit (research and development board/kit) (hereinafter the "board") is not a finished product and is as such not available for sale to consumers. The board is only intended for research, development, demonstration and evaluation purposes and should as such only be used in laboratory/development areas by persons with an engineering/technical training and familiar with the risks associated with handling electrical/mechanical components, systems and subsystems. This person assumes full responsibility/liability for proper and safe handling. Any other use, resale or redistribution for any other purpose is strictly prohibited.

The board is delivered "AS IS" and without warranty of any kind including, but not limited to, that the board is production-worthy, that the functions contained in the board will meet your requirements, or that the operation of the board will be uninterrupted or error free. ON Semiconductor expressly disclaims all warranties, express, implied or otherwise, including without limitation, warranties of fitness for a particular purpose and non-infringement of intellectual property rights.

ON Semiconductor reserves the right to make changes without further notice to any board.

You are responsible for determining whether the board will be suitable for your intended use or application or will achieve your intended results. Prior to using or distributing any systems that have been evaluated, designed or tested using the board, you agree to test and validate your design to confirm the functionality for your application. Any technical, applications or design information or advice, quality characterization, reliability data or other services provided by ON Semiconductor shall not constitute any representation or warranty by ON Semiconductor, and no additional obligations or liabilities shall arise from ON Semiconductor having provided such information or services.

The boards are not designed, intended, or authorized for use in life support systems, or any FDA Class 3 medical devices or medical devices with a similar or equivalent classification in a foreign jurisdiction, or any devices intended for implantation in the human body. Should you purchase or use the board for any such unintended or unauthorized application, you shall indemnify and hold ON Semiconductor and its officers, employees, subsidiaries, affiliates, and distributors harmless against all claims, costs, damages, and expenses, and reasonable attorney fees arising out of, directly or indirectly, any claim of personal injury or death associated with such unintended or unauthorized use, even if such claim alleges that ON Semiconductor was negligent regarding the design or manufacture of the board.

This evaluation board/kit does not fall within the scope of the European Union directives regarding electromagnetic compatibility, restricted substances (RoHS), recycling (WEEE), FCC, CE or UL, and may not meet the technical requirements of these or other related directives.

**FCC WARNING** – This evaluation board/kit is intended for use for engineering development, demonstration, or evaluation purposes only and is not considered by ON Semiconductor to be a finished end product fit for general consumer use. It may generate, use, or radiate radio frequency energy and has not been tested for compliance with the limits of computing devices pursuant to part 15 of FCC rules, which are designed to provide reasonable protection against radio frequency interference. Operation of this equipment may cause interference with radio communications, in which case the user shall be responsible, at its expense, to take whatever measures may be required to correct this interference.

ON Semiconductor does not convey any license under its patent rights nor the rights of others.

**LIMITATIONS OF LIABILITY:** ON Semiconductor shall not be liable for any special, consequential, incidental, indirect or punitive damages, including, but not limited to the costs of requalification, delay, loss of profits or goodwill, arising out of or in connection with the board, even if ON Semiconductor is advised of the possibility of such damages. In no event shall ON Semiconductor's aggregate liability from any obligation arising out of or in connection with the board, under any theory of liability, exceed the purchase price paid for the board, if any.

For more information and documentation, please visit [www.onsemi.com](http://www.onsemi.com).

---

## PUBLICATION ORDERING INFORMATION

### LITERATURE FULFILLMENT:

Email Requests to: [orderlit@onsemi.com](mailto:orderlit@onsemi.com)

ON Semiconductor Website: [www.onsemi.com](http://www.onsemi.com)

### TECHNICAL SUPPORT

North American Technical Support:

Voice Mail: 1 800-282-9855 Toll Free USA/Canada

Phone: 011 421 33 790 2910

Europe, Middle East and Africa Technical Support:

Phone: 00421 33 790 2910

For additional information, please contact your local Sales Representative