



Timing-Safe™ Peak EMI Reduction IC

General Features

- Clock distribution with Timing-Safe™ Peak EMI Reduction
- Input frequency range: 20MHz - 50MHz
- 2 different Spread Selection options
- Spread Spectrum can be turned ON/OFF
- External Input-Output Delay Control option
- Supply Voltage: 3.3V±0.3V
- Commercial and Industrial temperature range
- Packaging Information:
 - ASM3P623S00B: 8 pin TSSOP
 - ASM3P623S00E: 16 pin TSSOP
- The First True Drop-in Solution

Functional Description

ASM3P623S00B/E is a versatile, 3.3V Zero-delay buffer designed to distribute Timing-Safe™ clocks with Peak EMI reduction. ASM3P623S00B is an eight-pin version, accepts one reference input and drives out one low-skew Timing-

Safe™ clock. ASM3P623S00E accepts one reference input and drives out eight low-skew Timing-Safe™ clocks.

ASM3P623S00B/E has an SS% that selects 2 different Deviation and associated Input-Output Skew (T_{SKEW}). Refer to the *Spread Spectrum Control* and *Input-Output Skew* table for details.

ASM3P623S00E has a CLKOUT for adjusting the Input-Output clock delay, depending upon the value of capacitor connected at this pin to GND.

ASM3P623S00B/E operates from a 3.3V supply and is available in two different packages, as shown in the ordering information table, over commercial and Industrial temperature range.

Application

ASM3P623S00B/E is targeted for use in Displays and memory interface systems.

General Block Diagram

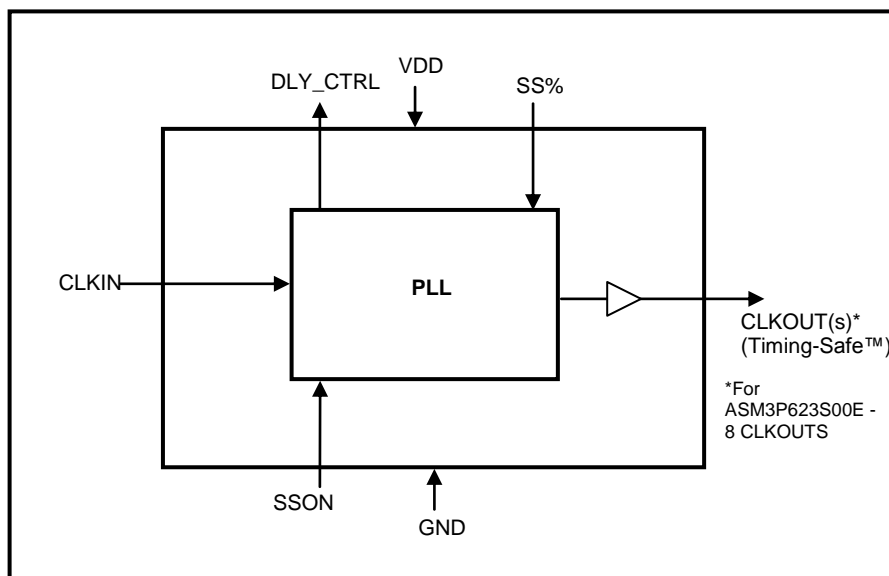

Spread Spectrum Frequency Generation

The clocks in digital systems are typically square waves with a 50% duty cycle and as frequencies increase the edge rates also get faster. Analysis shows that a square wave is composed of fundamental frequency and harmonics. The fundamental frequency and harmonics generate the energy peaks that become the source of EMI. Regulatory agencies test electronic equipment by measuring the amount of peak energy radiated from the equipment. In fact, the peak level allowed decreases as the frequency increases. The standard methods of reducing EMI are to use shielding, filtering, multi-layer PCBs, etc. These methods are expensive. Spread spectrum clocking reduces the peak energy by reducing the Q factor of the clock. This is done by slowly modulating the clock frequency. The ASM3P623S00B/E uses the center modulation spread spectrum technique in which the modulated output frequency varies above and below the reference frequency with a specified modulation rate. With center modulation, the average frequency is the same as the unmodulated frequency and there is no performance degradation

Zero Delay and Skew Control

All outputs should be uniformly loaded to achieve Zero Delay between input and output. Since the CLKOUT pin is the internal feedback to the PLL, its relative loading can adjust the input-output delay.

For applications requiring zero input-output delay, all outputs, including CLKOUT, must be equally loaded. Even if CLKOUT is not used, it must have a capacitive load equal to that on other outputs, for obtaining zero input-output delay.

Timing-Safe™ technology

Timing-Safe™ technology is the ability to modulate a clock source with Spread Spectrum technology and maintain synchronization with any associated data path.

Pin Configuration for ASM3P623S00B

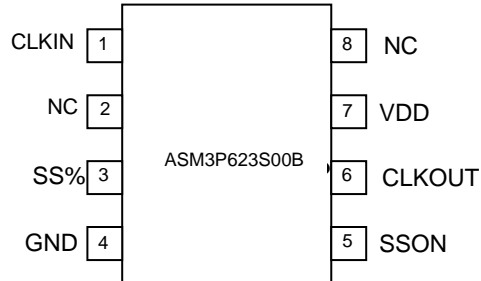

Pin Description for ASM3P623S00B

Pin #	Pin Name	Type	Description
1	CLKIN ¹	I	External reference Clock input , 5V tolerant input
2	NC		No Connect
3	SS% ³	I	Spread Spectrum Selection. Has an internal pull up resistor
4	GND	P	Ground
5	SSON ³	I	Spread Spectrum enable and disable option. When SSON is HIGH, the spread spectrum is enabled and when LOW, it turns off the spread spectrum. Has an internal pull up resistor
6	CLKOUT ²	O	Buffered clock output ⁴
7	VDD	P	3.3V supply
8	NC		No Connect

- Notes:
1. Weak pull down
 2. Weak pull-down on all outputs
 3. Weak pull-up on these Inputs
 4. Buffered clock output is Timing-Safe™

Pin Configuration

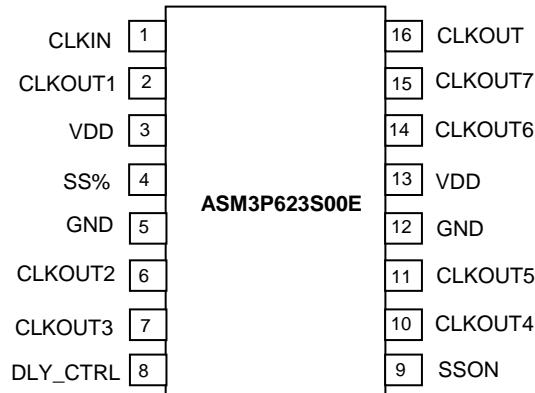

Pin Description for ASM3P623S00E

Pin #	Pin Name	Type	Description
1	CLKIN ¹	I	External reference Clock input, 5V tolerant input
2	CLKOUT1 ²	O	Buffered clock output ⁴
3	V _{DD}	P	3.3V supply
4	SS% ³	I	Spread Spectrum Selection. Refer to the <i>Spread Spectrum Control and Input-Output Skew Table</i> . Has an internal pull up resistor.
5	GND	P	Ground
6	CLKOUT2 ²	O	Buffered clock output ⁴
7	CLKOUT3 ²	O	Buffered clock output ⁴
8	DLY_CTRL	O	External Input-Output Delay control.
9	SSON ³	I	Spread Spectrum enable and disable option. When SSON is HIGH, the spread spectrum is enabled and when LOW, it turns off the spread spectrum. Has an internal pull up resistor.
10	CLKOUT4 ²	O	Buffered clock output ⁴
11	CLKOUT5 ²	O	Buffered clock output ⁴
12	GND	P	Ground
13	V _{DD}	P	3.3V supply
14	CLKOUT6 ²	O	Buffered clock output ⁴
15	CLKOUT7 ²	O	Buffered clock output ⁴
16	CLKOUT ²	O	Buffered clock output ⁴

Notes: 1. Weak pull down

2. Weak pull-down on all outputs

3. Weak pull-up on these Inputs

4. Buffered clock output is Timing-Safe™

Spread Spectrum Control and Input-Output Skew Table

Device	Input Frequency	SS %	Deviation	Input-Output Skew ($\pm T_{SKEW}$)
ASM3P623S00B/E	32MHz	0	$\pm 0.25\%$	0.125
		1	$\pm 0.50\%$	0.25

Note: T_{SKEW} is measured in units of the Clock Period

Absolute Maximum Ratings

Symbol	Parameter	Rating	Unit
VDD	Supply Voltage to Ground Potential	-0.5 to +4.6	V
VIN	DC Input Voltage (CLKIN)	-0.5 to +7	
T_{STG}	Storage temperature	-65 to +125	°C
T_s	Max. Soldering Temperature (10 sec)	260	°C
T_J	Junction Temperature	150	°C
T_{DV}	Static Discharge Voltage (As per JEDEC STD22- A114-B)	2	KV

Note: These are stress ratings only and are not implied for functional use. Exposure to absolute maximum ratings for prolonged periods of time may affect device reliability.

Operating Conditions

Parameter	Description	Min	Max	Unit
VDD	Supply Voltage	3.0	3.6	V
T_A	Operating Temperature (Ambient Temperature)	-40	+85	°C
C_L	Load Capacitance		30	pF
C_{IN}	Input Capacitance		7	pF

Electrical Characteristics

Parameter	Description	Test Conditions	Min	Typ	Max	Unit
V_{IL}	Input LOW Voltage ⁵				0.8	V
V_{IH}	Input HIGH Voltage ⁵		2.0			V
I_{IL}	Input LOW Current	$V_{IN} = 0V$			50	μA
I_{IH}	Input HIGH Current	$V_{IN} = VDD$			100	μA
V_{OL}	Output LOW Voltage ⁶	$I_{OL} = 8mA$			0.4	V
V_{OH}	Output HIGH Voltage ⁶	$I_{OH} = -8mA$	2.4			V
I_{DD}	Supply Current	Unloaded outputs			27	mA
Z_o	Output Impedance			23		Ω

Notes: 5. CLKIN input has a threshold voltage of $VDD/2$

6. Parameter is guaranteed by design and characterization. Not 100% tested in production.

Switching Characteristics

Parameter	Test Conditions	Min	Typ	Max	Unit
Input Frequency		20		50	MHz
Output Frequency	30pF load	20		50	MHz
Duty Cycle ^{6,7} = $(t_2 / t_1) * 100$	Measured at VDD/2	40	50	60	%
Output Rise Time ^{7,8}	Measured between 0.8V and 2.0V			2.5	nS
Output Fall Time ^{7,8}	Measured between 2.0V and 0.8V			2.5	nS
Output-to-output skew ^{7,8}	All outputs equally loaded with SSOFF			250	pS
Delay, CLKIN Rising Edge to CLKOUT Rising Edge ⁸	Measured at VDD /2 with SSOFF			±350	pS
Device-to-Device Skew ⁸	Measured at VDD/2 on the CLKOUT pins of the device			700	pS
Cycle-to-Cycle Jitter ^{7,8}	Loaded outputs			±250	pS
PLL Lock Time ⁸	Stable power supply, valid clock presented on CLKIN pin			1.0	mS

Note: 7. All parameters specified with 30pF loaded outputs.

8. Parameter is guaranteed by design and characterization. Not 100% tested in production.

Switching Waveforms

Duty Cycle Timing

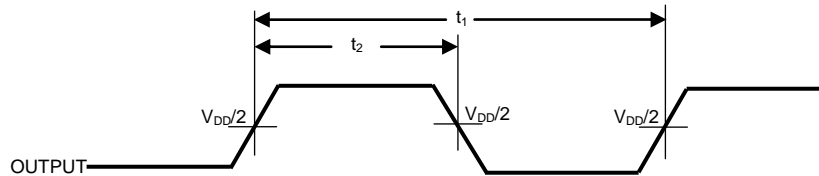

All Outputs Rise/Fall Time

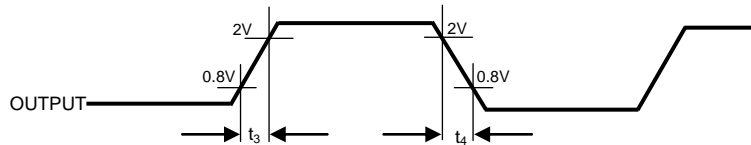

Output - Output Skew

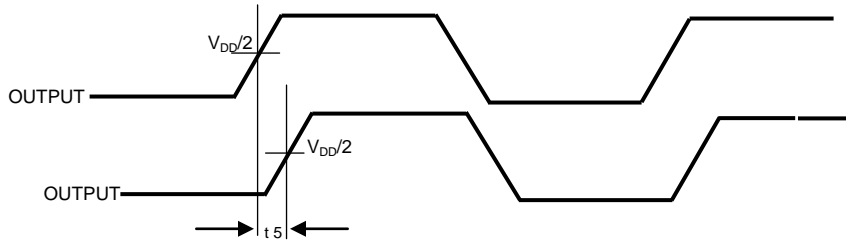

Input - Output Propagation Delay

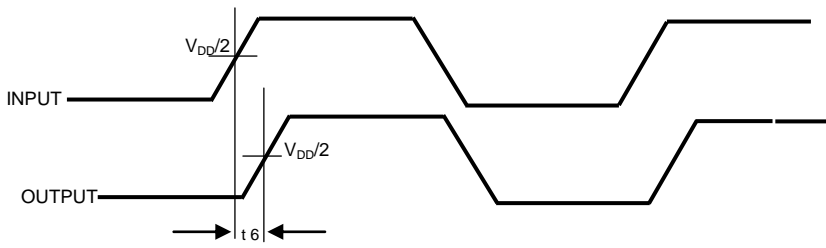

Device - Device Skew

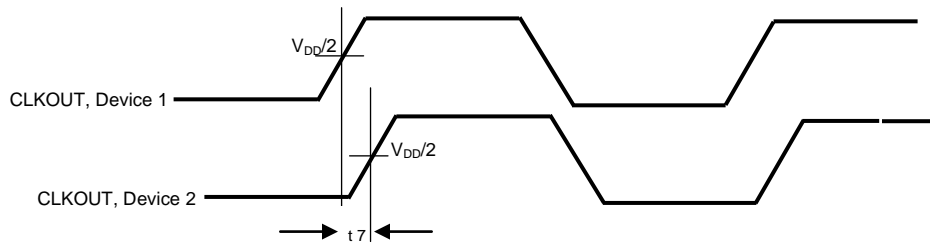

Input - Output Skew

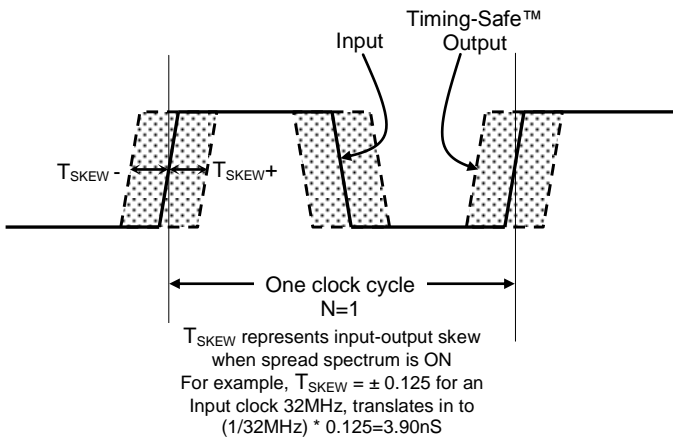

Test Circuit

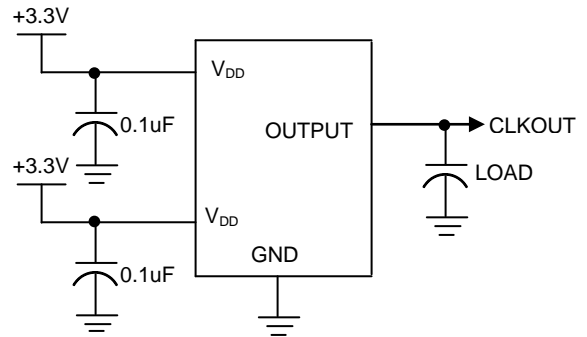

Typical example of Timing-Safe™ waveform

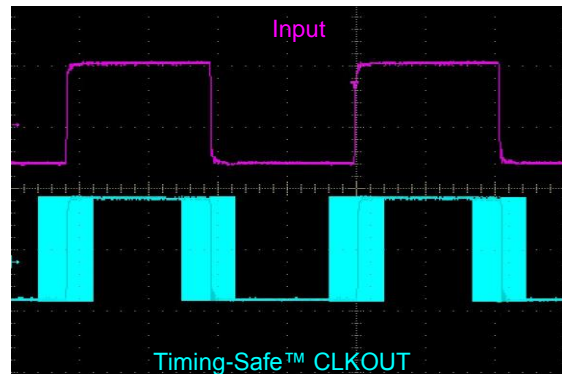
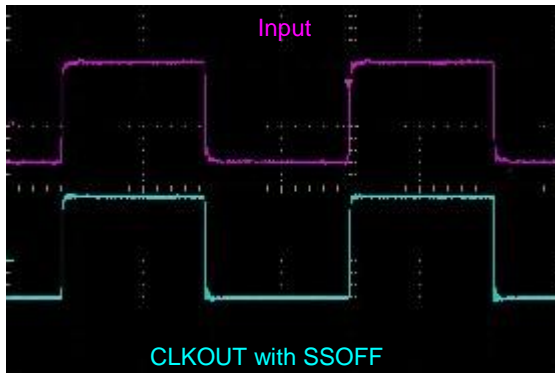

Package Information

8-lead TSSOP (4.40-MM Body)

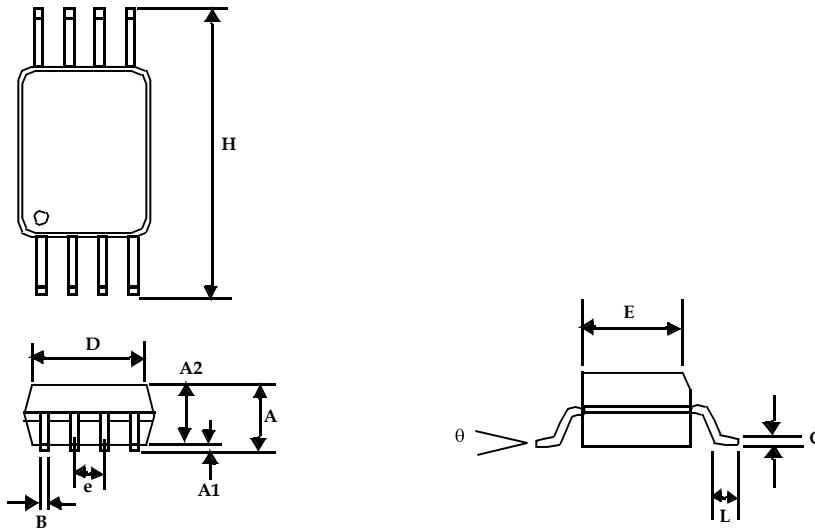

Symbol	Dimensions			
	Inches		Millimeters	
	Min	Max	Min	Max
A		0.043		1.10
A1	0.002	0.006	0.05	0.15
A2	0.033	0.037	0.85	0.95
B	0.008	0.012	0.19	0.30
c	0.004	0.008	0.09	0.20
D	0.114	0.122	2.90	3.10
E	0.169	0.177	4.30	4.50
e	0.026 BSC		0.65 BSC	
H	0.252 BSC		6.40 BSC	
L	0.020	0.028	0.50	0.70
θ	0°	8°	0°	8°

16-lead TSSOP (4.40-MM Body)

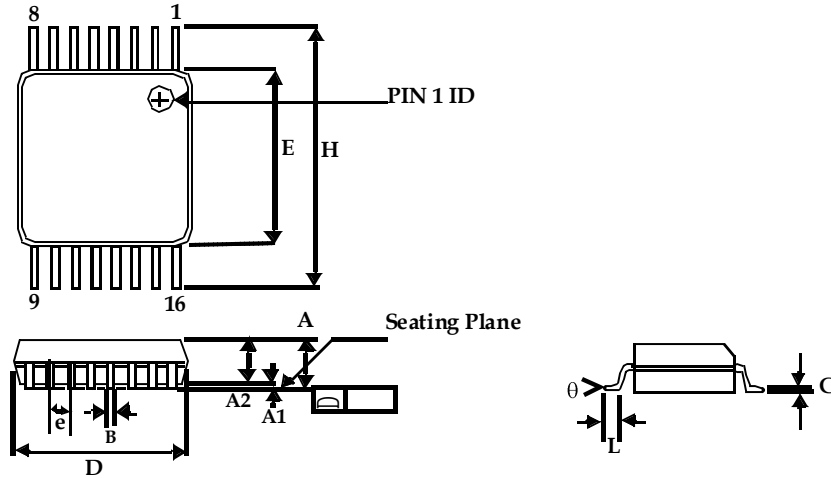

Symbol	Dimensions			
	Inches		Millimeters	
	Min	Max	Min	Max
A		0.043		1.20
A1	0.002	0.006	0.05	0.15
A2	0.031	0.041	0.80	1.05
B	0.007	0.012	0.19	0.30
C	0.004	0.008	0.09	0.20
D	0.193	0.201	4.90	5.10
E	0.169	0.177	4.30	4.50
e	0.026 BSC		0.65 BSC	
H	0.252 BSC		6.40 BSC	
L	0.020	0.030	0.50	0.75
θ	0°	8°	0°	8°

ASM3P62300B/E

Ordering Code

Ordering Code	Marking	Package Type	Temperature
P3P623S00BG-08TR	ADO	8 TSSOP TAPE & REEL, Green	0°C to +70°C
P3I623S00BG-08TR	ADP	8 TSSOP TAPE & REEL, Green	-40°C to +85°C
P3P623S00EG-16TR	P623 S00E	16 TSSOP TAPE & REEL, Green	0°C to +70°C

Licensed under US patent #5,488,627, #6,646,463 and #5,631,920.

Note: This product utilizes US Patent # 6,646,463 Impedance Emulator Patent issued to PulseCore Semiconductor, dated 11-11-2003

ON Semiconductor and  are registered trademarks of Semiconductor Components Industries, LLC (SCILLC). SCILLC reserves the right to make changes without further notice to any products herein. SCILLC makes no warranty, representation or guarantee regarding the suitability of its products for any particular purpose, nor does SCILLC assume any liability arising out of the application or use of any product or circuit, and specifically disclaims any and all liability, including without limitation special, consequential or incidental damages. "Typical" parameters which may be provided in SCILLC data sheets and/or specifications can and do vary in different applications and actual performance may vary over time. All operating parameters, including "Typicals" must be validated for each customer application by customer's technical experts. SCILLC does not convey any license under its patent rights nor the rights of others. SCILLC products are not designed, intended, or authorized for use as components in systems intended for surgical implant into the body, or other applications intended to support or sustain life, or for any other application in which the failure of the SCILLC product could create a situation where personal injury or death may occur. Should Buyer purchase or use SCILLC products for any such unintended or unauthorized application, Buyer shall indemnify and hold SCILLC and its officers, employees, subsidiaries, affiliates, and distributors harmless against all claims, costs, damages, and expenses, and reasonable attorney fees arising out of, directly or indirectly, any claim of personal injury or death associated with such unintended or unauthorized use, even if such claim alleges that SCILLC was negligent regarding the design or manufacture of the part. SCILLC is an Equal Opportunity/Affirmative Action Employer. U.S. Patent Pending; Timing-Safe and Active Bead are trademarks of PulseCore Semiconductor, a wholly owned subsidiary of ON Semiconductor. This literature is subject to all applicable copyright laws and is not for resale in any manner.

PUBLICATION ORDERING INFORMATION

LITERATURE FULFILLMENT:

Literature Distribution Center for ON Semiconductor
P.O. Box 5163, Denver, Colorado 80217 USA
Phone: 303-675-2175 or 800-344-3860 Toll Free USA/Canada
Fax: 303-675-2176 or 800-344-3867 Toll Free USA/Canada
Email: orderlit@onsemi.com

N. American Technical Support: 800-282-9855
Toll Free USA/Canada
Europe, Middle East and Africa Technical Support:
Phone: 421 33 790 2910
Japan Customer Focus Center
Phone: 81-3-5773-3850

ON Semiconductor Website: www.onsemi.com

Order Literature: <http://www.onsemi.com/orderlit>

For additional information, please contact your local Sales Representative