

# RHYTHM SB3229

## Pre-configured DSP System for Hearings Aids

### Description

ON Semiconductor's RHYTHM™ SB3229 hybrid is a trimmer-configurable DSP system based on a four-channel compression circuit featuring a feedback cancellation algorithm.

Based on a phase cancellation method, Rhythm SB3229's adaptive feedback reduction algorithm provides added stable gain to enable extra gain and user comfort. It features rapid adjustment for dynamic feedback situations and resistance to tonal inputs.

In addition to these adaptive algorithms, Rhythm SB3229 also supports the following features: up to four channel WDRC, low-distortion compression limiting, cross fading between audio paths for click-free memory changes, eight-band graphic equalizer, eight configurable generic biquad filters, programming speed enhancements, in-channel squelch to attenuate microphone and circuit noise in quiet environments, optional peak clipping, flexible compression adjustments, volume control, rocker switch, noise generation for Tinnitus treatment, and industry-leading security features to avoid cloning and software piracy.

A trimmer interface supports manual circuit configuration. It continuously monitors trimmer positions and translates them into the hearing-aid parameters of choice. A Serial Data or I<sup>2</sup>C Interface provides full programmability at the factory and in the field.

The Rhythm SB3229 hybrid contains a 256 kbit EEPROM intended for programmable and trimmer based devices.

### Features

- Adaptive Feedback Cancellation
- WDRC Compression with Choice of 1, 2 or 4 Channels of Compression
- Auto Telecoil with Programmable Delay
- EVOKE LITE™ Acoustic Indicators
- Noise Generator for Tinnitus Treatment or In-Situ Audiometry
- Frequency Response Shaping with Graphic EQ
- Trimmer Compatibility – Four Three-Terminal Trimmers with Configurable Assignments of Control Parameters
- I<sup>2</sup>C and SDA Programming
- Rocker Switch Support for Memory Change and/or Volume Control Adjustment
- Analog or Digital Volume Control with Programmable Range
- High Quality 20-bit Audio Processing
- High Power/High Gain Capability
- SOUNDFIT® Fitting Software
- Configurable Low Battery Indicator



ON Semiconductor®

<http://onsemi.com>

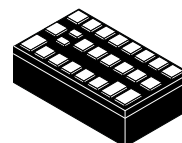

25 PAD  
HYBRID  
CASE TBD

### PAD CONNECTION

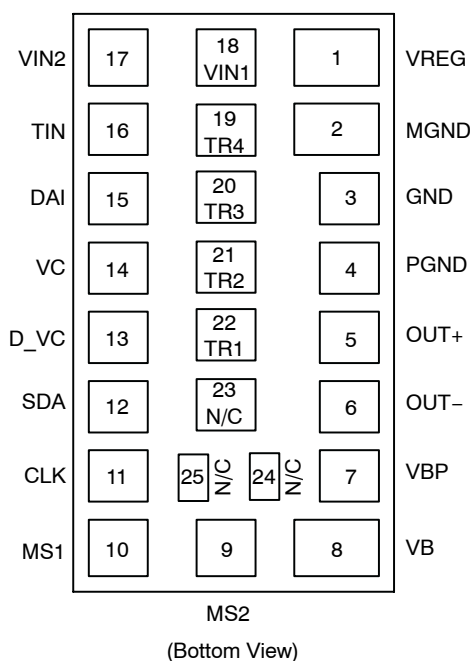

### MARKING DIAGRAM

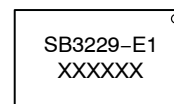

SB3229 = Specific Device Code  
E1 = RoHS Compliant Hybrid  
XXXXXX = Work Order Number

### ORDERING INFORMATION

See detailed ordering and shipping information on page 12 of this data sheet.

# RHYTHM SB3229

- Eight Biquadratic Filters
- 16 kHz or 8 kHz Bandwidth
- Four Fully Configurable Memories with Audible Memory Change Indicator
- 96 dB Input Dynamic Range with HRX™ Headroom Extension
- 128-bit Fingerprint Security System and Other Security Features to Protect Against Device Cloning and Software Piracy
- High Fidelity Audio CODEC
- Soft Acoustic Fade between Memory Changes
- Drives Zero-Bias Two-Terminal Receivers
- E1 RoHS-compliant Hybrid
- Hybrid Typical Dimensions:  
0.220 x 0.125 x 0.060 in  
(5.59 x 3.18 x 1.52 mm)

## BLOCK DIAGRAM

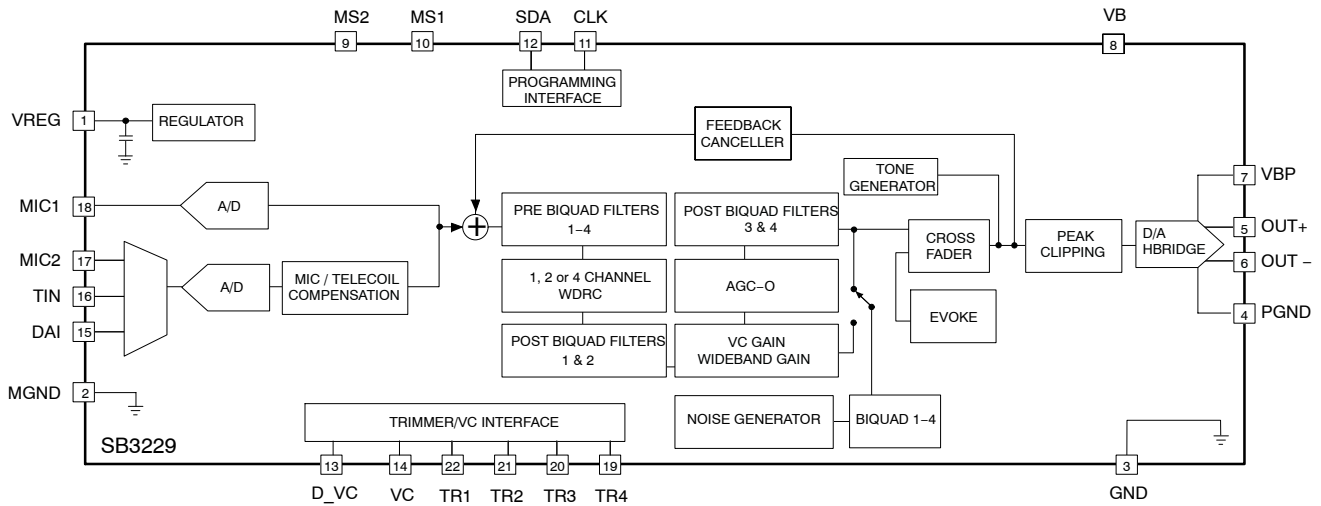

Figure 1. Hybrid Block Diagram

# RHYTHM SB3229

## SPECIFICATIONS

**Table 1. ABSOLUTE MAXIMUM RATINGS**

Parameter	Value	Units
Operating Temperature Range	0 to +40	°C
Storage Temperature Range	-20 to +70	°C
Absolute Maximum Power Dissipation	25	mW
Maximum Operating Supply Voltage	1.65	VDC
Absolute Maximum Supply Voltage	1.8	VDC

Stresses exceeding Maximum Ratings may damage the device. Maximum Ratings are stress ratings only. Functional operation above the Recommended Operating Conditions is not implied. Extended exposure to stresses above the Recommended Operating Conditions may affect device reliability.

**WARNING:** Electrostatic Sensitive Device – Do not open packages or handle except at a static-free workstation.

**WARNING:** Moisture Sensitive Device – RoHS Compliant; Level 4 MSL. Do not open packages except under controlled conditions.

**Table 2. ELECTRICAL CHARACTERISTICS** (Supply Voltage  $V_B = 1.25$  V; Temperature = 25°C)

Parameter	Symbol	Conditions	Min	Typ	Max	Units
Hybrid Current	$I_{AMP}$	All functions, 32 kHz sampling rate	-	640	-	$\mu$ A
		All functions, 16 kHz sampling rate	-	535	-	
Minimum Operating Supply Voltage	$V_{BOFF}$	Ramp down, audio path	0.93	0.95	0.97	V
		Ramp down, control logic	0.77	0.80	0.83	
Supply Voltage Turn On Threshold	$V_{BON}$	Ramp up	1.06	1.10	1.16	V
EEPROM Burn Cycles	-	-	100 k	-	-	cycles
Low Frequency System Limit	-	-	-	125	-	Hz
High Frequency System Limit	-	-	-	16	-	kHz
Total Harmonic Distortion	THD	$V_{IN} = -40$ dBV	-	-	1	%
THD at Maximum Input	THD <sub>M</sub>	$V_{IN} = -15$ dBV, HRX – ON	-	-	3	%
Clock Frequency	$f_{CLK}$	-	3.973	4.096	4.218	MHz
Audio Path Latency	-	8 kHz bandwidth	-	4.2	-	ms
		16 kHz bandwidth	-	4.0	-	
System Power On Time (Note 1)	-	SB3229	-	1600	-	ms

### REGULATOR

Regulator Voltage	$V_{REG}$	-	0.87	0.90	0.93	V
System PSRR	PSRR <sub>SYS</sub>	1 kHz, Input referred, HRX enabled	-	70	-	dB

### INPUT

Input Referred Noise	IRN	Bandwidth 100 Hz – 8 kHz, HRX on	-	-108	-106	dBV
Input Impedance	$Z_{IN}$	1 kHz	-	3	-	M $\Omega$
Anti-aliasing Filter Rejection	-	$f = f_{CLK}/2 - 8$ kHz, $V_{IN} = -40$ dBV	-	80	-	dB
Crosstalk	-	Between both A/D and Mux	-	60	-	dB
Maximum Input Level	-	-	-15	-13	-	dBV
Analogue Input Voltage Range	$V_{AN\_IN}$	$V_{IN1}, V_{IN2}, AI$	0	-	800	mV
	$V_{AN\_TIN}$	$T_{IN}$	-100	-	800	
Input Dynamic Range	-	HRX – ON Bandwidth 100 Hz – 8 kHz	-	95	96	dB

1. Times do not include additional programmable startup delay.

# RHYTHM SB3229

**Table 2. ELECTRICAL CHARACTERISTICS** (Supply Voltage  $V_B = 1.25\text{ V}$ ; Temperature =  $25^\circ\text{C}$ )

Parameter	Symbol	Conditions	Min	Typ	Max	Units
<b>OUTPUT</b>						
D/A Dynamic Range	-	100 Hz – 8 kHz	-	88	-	dB
Output Impedance	$Z_{OUT}$	-	-	10	13	$\Omega$
<b>CONTROL A/D</b>						
Resolution (monotonic)	-	-	7	-	-	bits
Zero Scale Level	-	-	-	0	-	V
Full Scale Level	-	-	-	$V_{REG}$	-	V
<b>VOLUME CONTROL</b>						
Volume Control Resistance	$R_{VC}$	Three-terminal connection	100	-	360	$k\Omega$
Volume Control Range	-	-	-	-	42	dB
<b>PC_SDA INPUT</b>						
Logic 0 Voltage	-	-	0	-	0.3	V
Logic 1 Voltage	-	-	1	-	1.25	V
<b>PC_SDA OUTPUT</b>						
Stand-by Pull Up Current	-	Creftrim = 6	3	5	6.5	$\mu\text{A}$
Sync Pull Up Current	-	Creftrim = 6	748	880	1020	$\mu\text{A}$
Max Sync Pull Up Current	-	Creftrim = 15	-	1380	-	$\mu\text{A}$
Min Sync Pull Up Current	-	Creftrim = 0	-	550	-	$\mu\text{A}$
Logic 0 Current (Pull Down)	-	Creftrim = 6	374	440	506	$\mu\text{A}$
Logic 1 Current (Pull Up)	-	Creftrim = 6	374	440	506	$\mu\text{A}$
Synchronization Time (Synchronization Pulse Width)	$T_{SYNC}$	Baud = 0	237	250	263	$\mu\text{s}$
		Baud = 1	118	125	132	
		Baud = 2	59	62.5	66	
		Baud = 3	29.76	31.25	32.81	
		Baud = 4	14.88	15.63	16.41	
		Baud = 5	7.44	7.81	8.20	
		Baud = 6	3.72	3.91	4.10	
		Baud = 7	1.86	1.95	2.05	

1. Times do not include additional programmable startup delay.

# RHYTHM SB3229

**Table 3. I<sup>2</sup>C TIMING**

Parameter	Symbol	Standard Mode		Fast Mode		Units
		Min	Max	Min	Max	
Clock Frequency	f <sub>PC_CLK</sub>	0	100	0	400	kHz
Hold time (repeated) START condition. After this period, the first clock pulse is generated.	t <sub>HD;STA</sub>	4.0	–	0.6	–	μsec
LOW Period of the PC_CLK Clock	t <sub>LOW</sub>	4.7	–	–	–	μsec
HIGH Period of the PC_CLK Clock	t <sub>HIGH</sub>	4.0	–	–	–	μsec
Set-up time for a repeated START condition	t <sub>SU;STA</sub>	4.7	–	–	–	μsec
Data Hold Time: for CBUS Compatible Masters for I <sup>2</sup> C-bus Devices	t <sub>HD;DAT</sub>	5.0 0 (Note 1)	– 3.4 (Note 2)	– 0 (Note 1)	– 0.9 (Note 2)	μsec
Data set-up time	t <sub>SU;DAT</sub>	250	–	100	–	nsec
Rise time of both PC_SDA and PC_CLK signals	t <sub>r</sub>	–	1000	20 + 0.1 C <sub>b</sub> (Note 4)	300	nsec
Fall time of both PC_SDA and PC_CLK signals	t <sub>f</sub>	–	300	20 + 0.1 C <sub>b</sub> (Note 4)	300	nsec
Set-up time for STOP condition	t <sub>SU;STO</sub>	4.0	–	0.6	–	nsec
Bus free time between a STOP and START condition	t <sub>BUF</sub>	4.7	–	1.3	–	μsec
Output fall time from V <sub>IHmin</sub> to V <sub>ILmax</sub> with a bus capacitance from 10 pF to 400 pF	t <sub>of</sub>	–	250	20 + 0.1 C <sub>b</sub> (Note 4)	250	nsec
Pulse width of spikes which must be suppressed by the input filter	t <sub>SP</sub>	n/a	n/a	0	50	nsec
Capacitive load for each bus line	C <sub>b</sub>	–	400	–	400	pF

1. A device must internally provide a hold time of at least 300 ns for the PC\_SDA signal to bridge the undefined region of the falling edge of PC\_CLK.
2. The maximum t<sub>HD;DAT</sub> has only to be met if the device does not stretch the LOW period (t<sub>LOW</sub>) of the PC\_CLK signal.
3. A Fast-mode I<sup>2</sup>C-bus device can be used in a Standard-mode I<sup>2</sup>C-bus system, but the requirement t<sub>SU;DAT</sub> ≥ 250ns must then be met. This will automatically be the case if the device does not stretch the LOW period of the PC\_CLK signal. If such a device does stretch the LOW period of the PC\_CLK signal, it must output the next data bit to the PC\_SDA line t<sub>r</sub> max + t<sub>SU;DAT</sub> = 1000 + 250 = 1250 ns (according to the Standard-mode I<sup>2</sup>C-bus specification) before the PC\_CLK line is released.
4. C<sub>b</sub> = total capacitance of one bus line in pF.

# RHYTHM SB3229

## TYPICAL APPLICATIONS

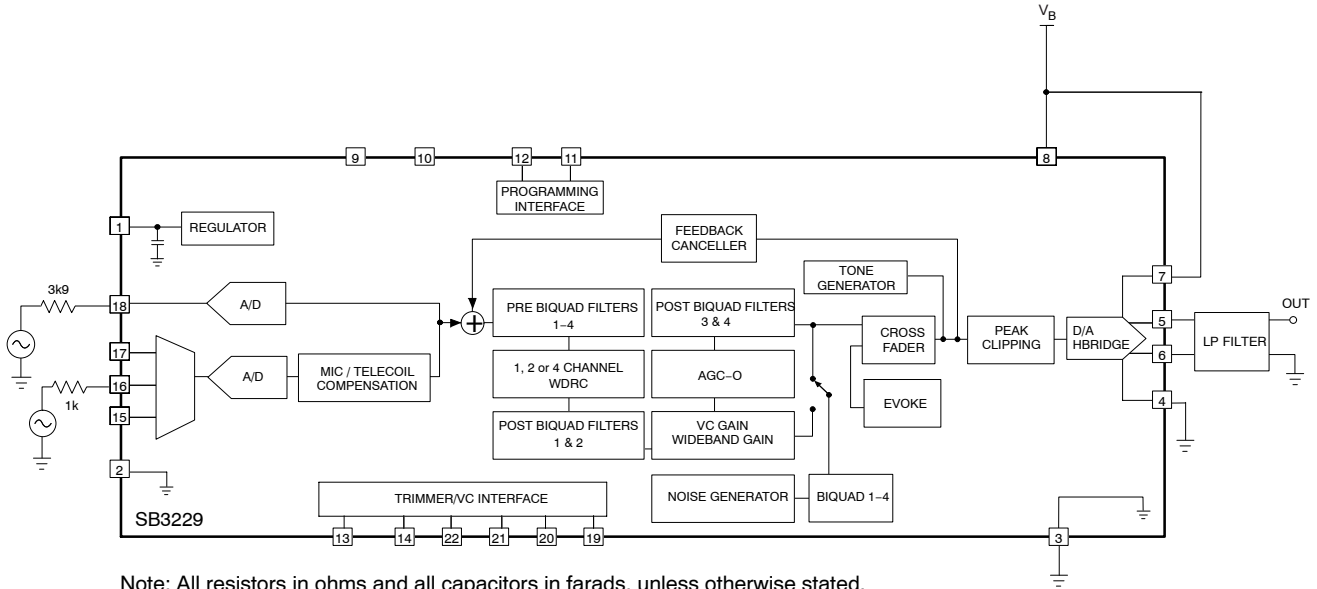

Figure 2. Test Circuit

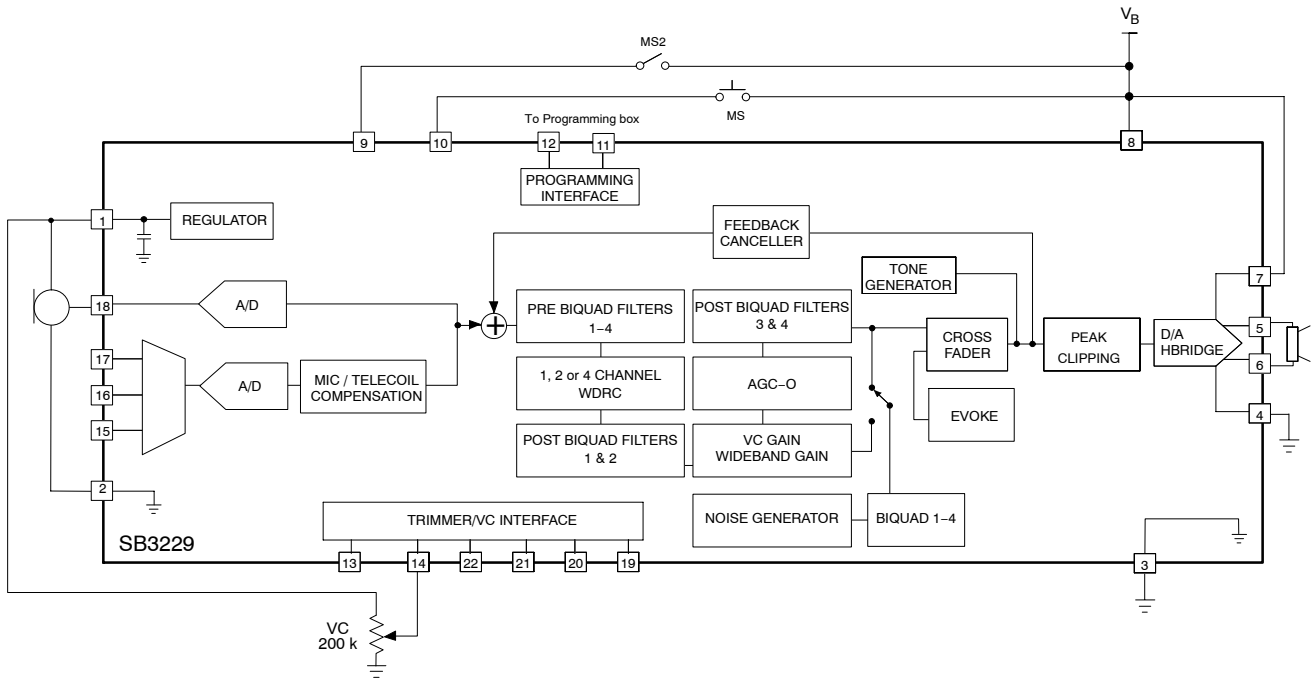
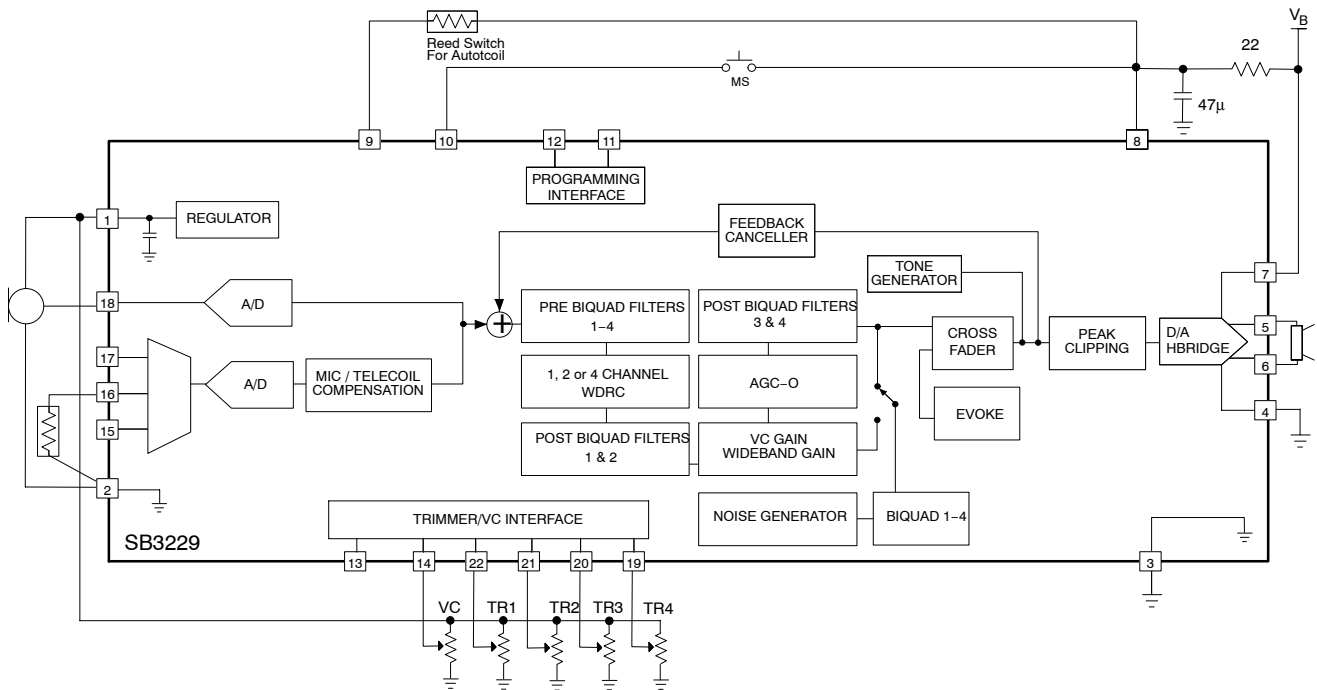

Figure 3. Typical Programmable Application Circuit

# RHYTHM SB3229

## TYPICAL APPLICATIONS (continued)



Note: All resistors in ohms and all capacitors in farads, unless otherwise stated.

Figure 4. Typical Trimmer Application Circuit

## RHYTHM SB3229 OVERVIEW

Rhythm SB3229 is a DSP system implemented on ON Semiconductor's Wolverine™ hardware platform. Wolverine is the hearing industry's first 90 nm Silicon-on-Chip platform enabling design of highly-efficient and flexible hearing aid solutions. The device is packaged for easy integration into a wide range of applications from CIC to BTE. Rhythm SB3229 can be used as a programmable or trimmer adjustable device. It may be configured as one, two or four channels with linear or WDRC processing. Configuration data stored in non-volatile memory defines hearing-aid parameters. Rhythm SB3229 can be programmed via the SDA or I<sup>2</sup>C programming interfaces.

The DSP core implements Adaptive Feedback Cancellation, compression, wideband gain, and volume control. The Adaptive Feedback Canceller reduces acoustic feedback while offering robust performance against pure tones.

During trimmer mode operation, a low-speed A/D circuit monitors the positions of up to four manual trimmers and a VC potentiometer. Trimmer position changes are immediately interpreted and translated into new circuit parameter values, which are then used to update the signal path.

## FUNCTIONAL BLOCK DESCRIPTION

### A/D and D/A Converter

The system's A/D converter is a 2nd-order sigma-delta modulator operating at a 2.048 MHz sample rate.

The system's input is pre-conditioned with anti-alias filtering and a programmable gain pre-amplifier. The analog output is oversampled and modulated to produce a 1-bit pulse density modulated (PDM) data stream. The digital PDM data is then decimated down to pulse-code

modulated (PCM) digital words at the system's sampling rate of 32 kHz.

The D/A is comprised of a digital 3rd-order sigma-delta modulator and an H-bridge. The modulator accepts PCM audio data from the DSP path and converts it into a 64-times oversampled, 1-bit PDM data stream, which is then supplied to the H-bridge. The H-bridge is a specialized CMOS output driver used to convert the 1-bit data stream

into a low-impedance, differential output voltage waveform suitable for driving zero-biased hearing aid receivers.

**Analog Inputs**

Rhythm SB3229 provides for up to four analog inputs, Microphone 1 (MIC1), Microphone 2 (MIC2), Telecoil (TCOIL) and Direct Audio Input (DAI) with the following configurable front end modes:

- MIC1
- MIC2
- DAI
- TCOIL
- MIC1 + TCOIL
- MIC1 + DAI

Attenuation can be applied to the MIC1 input when mixing with either TCOIL or DAI inputs.

**Channel Processing**

Figure 5 represents the I/O characteristic of independent AGC channel processing. The I/O curve can be divided into four main regions:

- Low input level expansion (squelch) region
- Low input level linear region
- Compression region
- High input level linear region (return to linear)

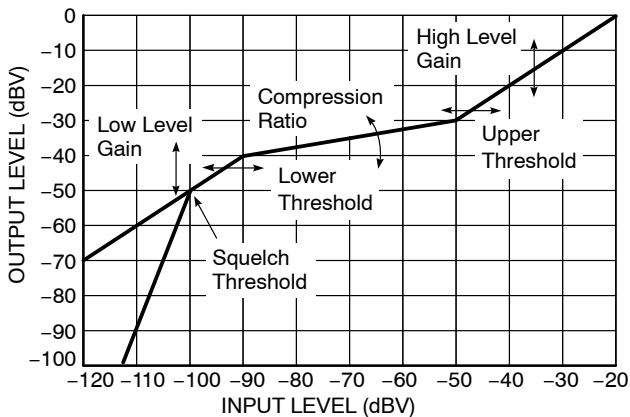

**Figure 5. Independent Channel I/O Curve Flexibility**

Channel I/O processing is specified by the Squelch threshold (SQUELCHTH) and any four of the following five parameters (only four of the five properties are independent):

- Low level gain (LLGAIN)
- Lower threshold (LTH)
- High level gain (HLGAIN)
- Upper threshold (UTH)
- Compression ratio (CR)

During the Parameter Map creation, constraints are applied to the compression parameters to ensure that the I/O characteristics are continuous. Parameter adjustments support two popular styles of compression ratio adjustment:

- The compression region of the I/O curve pivots about the upper threshold. As the compression ratio trimmer is adjusted, high-level gain remains constant while the low-level gain changes.
- The compression region of the I/O curve pivots about the lower threshold. Low-level gain remains constant as the compression ratio trimmer is adjusted.

The squelch region within each channel implements a low level noise reduction scheme (1:3 expansion) for listener comfort. This scheme operates in quiet listening environments (programmable threshold) to reduce the gain at very low levels.

**Automatic Telecoil**

The automatic telecoil feature in Rhythm SB3229 is to be used with memory D programmed with the telecoil or MIC + TCOIL front end configuration. The feature enables the part to transition to memory D upon the closing of a switch connected to MS2. With the feature enabled and a reed switch connected to MS2, the static magnetic field of a telephone handset will close the switch whenever the handset is brought close to the device, causing the hybrid to change to memory D. The part will transition back to the initial memory once the switch is deemed opened after proper debouncing.

A debounce algorithm with a programmable debounce period is used to prevent needless switching in and out of memory D due to physical switch bounces when MS2 is configured for automatic telecoil. Upon detecting a close to open switch transition, the debounce algorithm monitors the switch status. The debounce algorithm switches the device out of memory D only once the switch signal has been continuously sampled open over the specified debounce period.

**Adaptive Feedback Canceller**

The Adaptive Feedback Canceller (AFC) reduces acoustic feedback by forming an estimate of the hearing aid feedback signal and then subtracting this estimate from the hearing aid input. The forward path of the hearing aid is not affected. Unlike adaptive notch filter approaches, Rhythm SM3229's AFC does not reduce the hearing aid's gain. The AFC is based on a time-domain model of the feedback path.

The third-generation AFC (see Figure 6) allows for an increase in the stable gain<sup>1</sup> of the hearing instrument while minimizing artefacts for music and tonal input signals. As with previous products, the feedback canceller provides completely automatic operation.

1. Added stable gain will vary based on hearing aid style and acoustic setup. Please refer to the Adaptive Feedback Cancellation Information note for more details

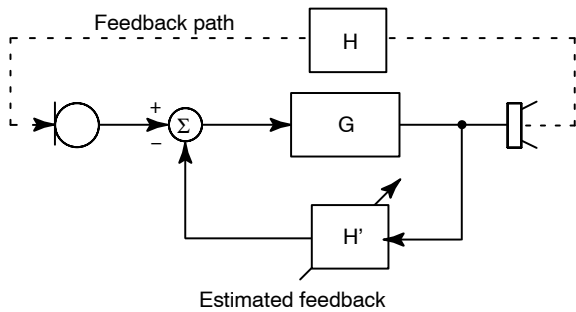

**Figure 6. Adaptive Feedback Canceller (AFC) Block Diagram**

### Volume Control, Trimmers and Switches

#### External Volume Control

The volume of the device can either be set statically via software or controlled externally via a physical interface.

Rhythm SB3229 supports both analog and digital volume control functionality, although only one can be enabled at a time. Digital control is supported with either a momentary switch or a rocker switch. In the latter case, the rocker switch can also be used to control memory selects.

#### Analog Volume Control

Both the external (analog) volume control and trimmers work with a three-terminal 100 kΩ – 360 kΩ variable resistor. The volume control can have either a log or linear taper, which is selectable via software. It is possible to use a VC with up to 1 MΩ of resistance, but this could result in a slight decrease in the resolution of the taper.

#### Trimmers

The trimmer interface provides the ability to control up to 19 hearing aid parameters through up to four trimmers. A single trimmer parameter can have up to 16 values and a single trimmer can control multiple parameters (e.g., Trimmer 1 can control compression ratio in all four channels simultaneously). The trimmer must be three-terminal 100 kΩ to 360 kΩ variable resistors and have a linear taper.

Parameters that can be assigned to trimmers include Low Cut, High Cut, Compression Ratio, Wideband Gain, Tinnitus (Noise Level, Low Cut Filter, High Cut Filter) Crossover Frequency, Lower Threshold, Upper Threshold, EQ Gain, Squelch Threshold, High Level Gain, Low Level Gain, AGC-O Threshold, Static Volume Control and Peak Clipper Threshold.

#### Digital Volume Control

The digital volume control makes use of two pins for volume control adjustment, VC and D\_VC, with momentary switches connected to each. Closure of the switch to the VC pin indicates a gain increase while closure

to the D\_VC pin indicates a gain decrease. Figure 7 shows how to wire the digital volume control to Rhythm SB3229.

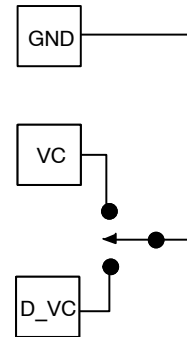

**Figure 7. Wiring for Digital Volume Control**

#### Memory Select Switches

Two Memory Select (MS) interfaces are available to support one or two 2-pole switches that can be used to switch between up to four memory profiles. The MS interface can be configured for the use of either momentary or static switches. The interface hardware can be configured to internally activate either a pull-up or pull-down resistor, depending on the physical wiring of the switch.

The audio path is temporarily faded-out and an acoustic indicator is optionally played out whenever the device transitions between memories. Each memory is assigned a unique acoustic indicator. See the Evoke Lite Acoustic Indicators section for details on the acoustic indicators and related configurations.

#### Momentary Switch on MS1

This mode uses a single momentary switch on MS1 input to change memories. Using this mode causes the part to start in memory A, and whenever the button is pressed, the next valid memory is loaded. When the user is in the last valid memory, a button press causes memory A to be loaded. Thus, the possible selection sequences are:

- If 4 valid memories: ABCDABCD...A...
- If 3 valid memories: ABCABCA...A...
- If 2 valid memories: ABABA...A...
- If 1 valid memory: AAA...A...

#### Momentary Switch on MS1, Static Switch on MS2 (D-only, Jump to Last Memory)

This mode uses a static switch on MS2 and a momentary switch on MS1 to change memories. It can be used to support the Automatic Telecoil feature (see Section Automatic Telecoil). If the static switch on MS2 is LOW, the part starts in memory A and is controlled by the momentary switch on MS1 as described in Section Momentary Switch on MS1, with the exception that memory D is not used. If the static switch on MS2 is set to HIGH, the part automatically jumps to memory D (occurs on start-up or during normal operation). In this setup, the state of the momentary switch

on MS1 is ignored. When MS2 is set to LOW, the part loads in the memory that was active prior to jumping to memory D.

The possible memory selection sequences are:

If MS2 = LOW and there are four valid memories, MS1 selects: ABCABCA...

If MS2 = LOW and there are three valid memories, MS1 selects: ABABA...

If MS2 = LOW and there is one valid memory: A

If MS2 = HIGH: D

**Static Switch on MS1, Static Switch on MS2 (D-only, Jump to Last Memory)**

This mode uses two static switches to change memories. Similar to the behaviour described in the Static Switch on MS1 and MS2 section, this mode will switch to memory D if the static switch on MS2 is HIGH (the state of the switch on MS1 is ignored). The mode, however, supports a maximum of three memories (even if four valid memories are programmed). This mode can be used to support the Automatic Telecoil feature (see the Automatic Telecoil section).

In this mode, it is possible to jump from any memory to any other memory by changing the state of both switches. If the two switches are changed one after the other, the part transitions to an intermediate memory before reaching the final memory.

The part starts in whatever memory the switches are selecting. If a memory is invalid, the part defaults to memory A.

**Table 4. STATIC SWITCH TRUTH TABLE: D-ONLY ENABLED**

Binary State (MS1/MS2)	Selected Memory
00	Memory A
10	Memory B
x1	Memory D

**Static Switch on MS1 and MS2**

This mode uses two static switches to change memories. In this mode, it is possible to jump from any memory to any other memory by changing the state of both switches. If the two switches are changed one after the other, the part transitions to an intermediate memory before reaching the final memory. The part starts in whatever memory the switches are selecting. If a memory is invalid, the part defaults to memory A.

**Table 5. STATIC SWITCH TRUTH TABLE: D-ONLY DISABLED**

Binary State (MS1/MS2)	Selected Memory
00	Memory A
10	Memory B
01	Memory C
11	Memory D

**Rocker Switch Support**

The device supports connection of a rocker switch to the digital volume control interface that can perform volume control (VC) adjustments and/or memory selection (MS).

There are three modes of operation:

- Digital Volume Control Mode
- Momentary Memory Select Mode
- Mixed Mode (VC and MS)

In Digital VC mode, the rocker switch provides the digital volume control functionality as described in this section.

In Momentary Memory Select mode, the rocker switch allows cycling through the memory profiles in both directions. An “up” switch closure indicates a program advance to the next *higher* numbered memory and “down” switch closures indicates a program retreat to the next *lower* numbered memory. In this mode, volume control is only available through software control.

In Mixed Mode, operation of the switch as a volume control or memory select is governed by the time duration of the switch closure: either short or long. The discrimination of short and long pulses is set by a programmable, time-threshold value, from 1 s to 5 s in 1 s increments. An additional programmable parameter determines whether the short pulses refer to volume-control operation or memory-select operation.

If long pulses control memory select operation, the memory change is initiated once the switch is held for the long pulse period without requiring the switch to be released. In Digital VC mode or Momentary Memory Select mode, the action takes place after the switch is released.

**AGC-O**

The AGC-O module is an output limiting circuit with a fixed compression ratio of ∞ : 1. The limiting level is programmable as a level measured in dB from full scale. The maximum output of the device is 0 dBFS.

The AGC-O module has its own level detector, with programmable attack and release time constants.

**Graphic Equalizer**

Rhythm SB3229 has a 8-band graphic equalizer. Each band provides up to 24 dB of gain adjustment in 1 dB increments.

## Biquadratic Filters

Additional frequency shaping can be achieved by configuring generic biquad filters. The transfer function for each of the biquad filters is as follows:

$$H(z) = \frac{b0 + b1 \times z^{-1} + b2 \times z^{-2}}{1 + a1 \times z^{-1} + a2 \times z^{-2}}$$

NOTE: The  $a0$  coefficient is hard-wired to always be '1'. The coefficients are each 16 bits in length and formatted as one sign bit, one integer bit and 14 fractional bits. This maps onto a decimal range of  $-2.0$  to  $2.0$  before quantization ( $-32767$  to  $32767$  after quantization).

Thus, before quantization, the floating-point coefficients must be in the range  $-2.0 \leq x < 2.0$  and quantized with the function:

$$\text{round}(x \times 2^{14})$$

After designing a filter, the quantized coefficients can be entered into the PreBiquads or PostBiquads tab in the Interactive Data Sheet. The coefficients  $b0$ ,  $b1$ ,  $b2$ ,  $a1$ , and  $a2$  are as defined in the transfer function above. The parameters  $\text{meta0}$  and  $\text{meta1}$  do not have any effect on the signal processing, but can be used to store additional information related to the associated biquad.

The underlying code in the product components automatically checks all of the filters in the system for stability (i.e., the poles have to be within the unit circle) before updating the graphs on the screen or programming the coefficients into the hybrid. If the Interactive Data Sheet receives an exception from the underlying stability checking code, it automatically disables the biquad being modified and displays a warning message. When the filter is made stable again, it can be re-enabled.

Also note that in some configurations, some of these filters may be used by the product component for microphone/telecoil compensation, low-frequency EQ, etc. If this is the case, the coefficients entered by the user into IDS are ignored and the filter designed by the software is programmed instead. For more information on filter design refer to the Biquad Filters In PARAGON® Digital Hybrid information note.

## Tinnitus Treatment Noise

The Tinnitus Treatment noise is generated using white noise generator hardware and shaping the generated noise using four 2<sup>nd</sup> order biquadratic filters. The filter parameters are the same coefficients as those presented in the Biquadratic Filters section.

The Tinnitus Treatment noise can be added into the signal path at two possible locations: before the VC (before the AGC-O, but compensated for the Wideband Gain) or after the VC (between the last generic biquad and the Cross Fader).

If the noise is injected before the VC then the level of the noise will change along with the rest of the audio through the

device when the VC is adjusted. If the noise is injected after the VC it is not affected by VC changes.

## EVOKE Lite Acoustic Indicators

Ten Acoustic Indicators are available for indicating events. Each indicator is fixed to a particular event. Any event can have its assigned indicator enabled or disabled although not always independently. Individual enable/disable control is provided for the following event or group of events:

- Power on reset (POR)
- Four memory selects
- Volume Up and Volume Down
- Volume Max and Volume Min
- Low Battery

Each Acoustic Indicator is made up of up to four faded tones. A faded tone exhibits a 64 ms fade-in and fade-out transition time. The duration of an Acoustic Indicator is configurable, with a maximum value of 6.35 seconds.

## Power Management

Rhythm SB3229 has three user-selectable power management schemes to ensure the hearing aid dies gracefully at the end of battery life. Shallow reset, Deep reset and Advanced Reset mode. It also contains a programmable power on reset delay function.

## Power On Reset Delay

The programmable POR delay controls the amount of time between power being connected to the hybrid and the audio output being enabled. This gives the user time to properly insert the hearing aid before the audio starts, avoiding the temporary feedback that can occur while the device is being inserted. During the delay period, momentary button presses are ignored.

## Power Management Functionality

As the voltage on the hearing aid battery decreases, an audible warning is given to the user indicating the battery life is low. In addition to this audible warning, the hearing aid takes other steps to ensure proper operation given the weak supply. The exact hearing aid behaviour in low supply conditions depends on the selected POR mode. The hearing aid has three POR modes:

- Shallow Reset Mode
- Deep Reset Mode
- Advanced Mode

## Shallow Reset Mode

In Shallow Reset mode, the hearing aid will operate normally when the battery is above 0.95 V. Once the supply voltage drops below 0.95 V the audio will be muted and remain in that state until the supply voltage rises above 1.1 V. Once the supply voltage drops below the control logic

## RHYTHM SB3229

ramp down voltage, the device will undergo a hardware reset. At this point, the device will remain off until the supply voltage returns to 1.1 V. When the supply voltage is below the control logic voltage, but above 0.6 V and rises above the 1.1 V turn on threshold, the device will activate its output and operate from the memory that was active prior to reset. If the supply voltage drops below 0.6 V, and rises above the 1.1 V turn on threshold, the device will reinitialize, activate its output and operate from memory A.

### Deep Reset Mode

In Deep Reset mode, the hearing aid will operate normally when the battery is above 0.95 V. Once the supply voltage drops below 0.95 V the audio will be muted. The device remains in this state until the supply voltage drops below the hardware reset voltage of 0.6 V. When this occurs, the device will load memory A and operate normally after the supply voltage goes above 1.1 V.

### Advanced Reset Mode

Advanced Reset Mode on Rhythm SB3229 is a more sophisticated power management scheme than shallow and deep reset modes. This mode attempts to maximize the device's usable battery life by reducing the gain to stabilize the supply based on the instantaneous and average supply voltage levels. Instantaneous supply fluctuations below 0.95 V can trigger up to two 3 dB, instantaneous gain reductions. Average supply drops below 0.95 V can trigger up to eighteen, 1 dB average gain reductions.

While the average supply voltage is above 0.95 V, an instantaneous supply voltage fluctuation below 0.95 V will trigger an immediate 3 dB gain reduction. After the 3 dB gain reduction has been applied, the advanced reset model holds off checking the instantaneous voltage level for a monitoring period of 30 second in order to allow the voltage level to stabilize. If after the stabilization time the instantaneous voltage drops a second time below 0.95 V during the next monitoring period, the gain will be reduced an additional 3 dB for a 6 dB total reduction and a 30 second stabilization time is activated. The advanced reset mode continues to monitor the instantaneous voltage levels over 30 second monitoring periods. If the instantaneous voltage remains above 1.1 V during that monitoring period, the gain will be restored to the original setting regardless of whether one or two gain reductions are applied. If two gain reductions are applied and the instantaneous voltage level remains above 1.0 V for a monitoring period, the gain will be restored to a 3 dB reduction.

### ORDERING INFORMATION

Device	Package	Shipping†
SA3229-E1	25 Pad Hybrid	25 Units / Bubble Pack
SA3229-E1-T	25 Pad Hybrid	500 Units / Tape & Reel

†For information on tape and reel specifications, including part orientation and tape sizes, please refer to our Tape and Reel Packaging Specifications Brochure, BRD8011/D.

### Hybrid Jig Ordering Information

To order a Hybrid Jig Evaluation Board for Rhythm SB3229 contact your Sales Account Manager or FAE and use part number SA3405GEVB.

Should the average supply voltage drop below 0.95 V, the device will then reduce the gain by 1 dB every 10 seconds until either the average supply voltage rises above 0.95 V or a total of 18 average gain reductions have been applied, at which point the audio path will be muted. If the average supply voltage returns to a level above 1.1 V, the audio path will first be un-muted, if required. The gain will then be increased by 1 dB every 10 seconds until either the average supply voltage drops below 1.1 V, or all average gain reductions have been removed. No action is taken while the average supply voltage resides between 0.95 V and 1.1 V.

NOTE: Instantaneous and average gain reductions are adjusted independently.

When the instantaneous voltage falls below the hardware shutdown voltage, the device will undergo a hardware reset. When it turns back on because the voltage has risen above the turn-on threshold of 0.6 V, it will behave the same as it would in shallow reset mode.

### Low Battery Notification

Notification of the low battery condition via an acoustic indicator is optionally performed when the battery voltage drops below a configurable low battery notification threshold. The low battery indicator is repeated every five minutes until the device shuts down.

### SDA and I<sup>2</sup>C Communication

Rhythm SB3229 can be programmed using the SDA or I<sup>2</sup>C protocol. During parameter changes, the main audio signal path of the hybrid is temporarily muted using the memory switch fader to avoid the generation of disturbing audio transients. Once the changes are complete, the main audio path is reactivated. Any changes made during programming are lost at power-off unless they are explicitly burned to EEPROM memory.

Improvements have been made to the ARK software, resulting in improved communication speed. Certain parameters in ARKonline<sup>®</sup> can be selected to reduce the number of pages that need to be read out. In SDA mode, Rhythm SB3229 is programmed via the SDA pin using industry standard programming boxes. I<sup>2</sup>C mode is a two-wire interface which uses the SDA pin for bidirectional data and CLK as the interface clock input. I<sup>2</sup>C programming support is available on the HiPro (serial or USB versions) and ON Semiconductor's DSP Programmer 3.0.

# RHYTHM SB3229

## PAD LOCATIONS

Table 6. PAD POSITION AND DIMENSIONS

Pad No.	Pad Position		Pad Dimension	
	X	Y	Xdim (mil)	Ydim (mil)
1	0	0	20	33
2	-27	0	20	33
3	-54	5	20	23
4	-81	5	20	23
5	-108	5	20	23
6	-135	5	20	23
7	-162	5	20	23
8	-189	0	20	33
9	-189	42	20	23
10	-189	85	20	23
11	-162	85	20	23
12	-135	85	20	23
13	-108	85	20	23
14	-81	85	20	23
15	-54	85	20	23
16	-27	85	20	23
17	0	85	20	23
18	0	42	20	23
19	-27	42	20	23
20	-54	42	20	23
21	-81	42	20	23
22	-108	42	20	23
23	-135	42	20	23
24	-162	26.5	18	12
25	-162	53.5	18	12

# RHYTHM SB3229

**Table 6. PAD POSITION AND DIMENSIONS**

Pad No.	X	Y	Xdim (mm)	Ydim (mm)
1	0	0	0.508	0.838
2	-0.686	0	0.508	0.838
3	-1.372	0.127	0.508	0.584
4	-2.057	0.127	0.508	0.584
5	-2.743	0.127	0.508	0.584
6	-3.429	0.127	0.508	0.584
7	-4.115	0.127	0.508	0.584
8	-4.801	0	0.508	0.838
9	-4.801	1.067	0.508	0.584
10	-4.801	2.159	0.508	0.584
11	-4.115	2.159	0.508	0.584
12	-3.429	2.159	0.508	0.584
13	-2.743	2.159	0.508	0.584
14	-2.057	2.159	0.508	0.584
15	-1.372	2.159	0.508	0.584
16	-0.686	2.159	0.508	0.584
17	0	2.159	0.508	0.584
18	0	1.067	0.508	0.584
19	-0.686	1.067	0.508	0.584
20	-1.372	1.067	0.508	0.584
21	-2.057	1.067	0.508	0.584
22	-2.743	1.067	0.508	0.584
23	-3.429	1.067	0.508	0.584
24	-4.115	0.673	0.457	0.305
25	-4.115	1.359	0.457	0.305

# RHYTHM SB3229

## PACKAGE DIMENSIONS

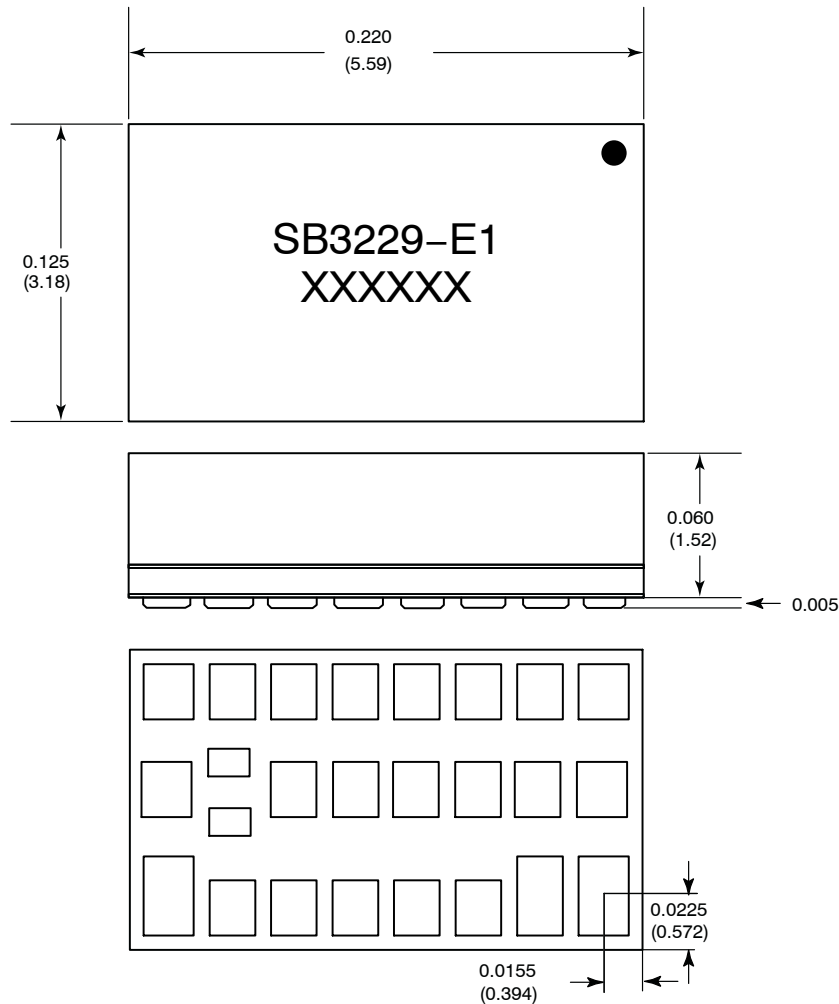

Dimension units are in inches.

Dimensions in parentheses are in millimeters, converted from inches and include minor rounding errors.

1.000 inches = 25.4 mm

Hybrid Dimension Tolerances:  $\pm 0.005$  ( $\pm 0.13$ )

Solder Pad Height Tolerances:  $\pm 0.002$  ( $\pm 0.05$ )

● = location of Pin 1

E1: RoHS compliant hybrid, MSL#4, 240°C peak reflow, SAC305.

This Hybrid is designed for either point-to-point manual soldering or for reflow according to ON Semiconductor's reflow process.

RHYTHM, HRX, WOLVERINE and EVOKE LITE are trademarks of Semiconductor Components Industries, LLC.

SOUNDFIT, PARAGON and ARKonline are registered trademarks of Semiconductor Components Industries, LLC.

ON Semiconductor and  are registered trademarks of Semiconductor Components Industries, LLC (SCILLC). SCILLC owns the rights to a number of patents, trademarks, copyrights, trade secrets, and other intellectual property. A listing of SCILLC's product/patent coverage may be accessed at [www.onsemi.com/site/pdf/Patent-Marking.pdf](http://www.onsemi.com/site/pdf/Patent-Marking.pdf). SCILLC reserves the right to make changes without further notice to any products herein. SCILLC makes no warranty, representation or guarantee regarding the suitability of its products for any particular purpose, nor does SCILLC assume any liability arising out of the application or use of any product or circuit, and specifically disclaims any and all liability, including without limitation special, consequential or incidental damages. "Typical" parameters which may be provided in SCILLC data sheets and/or specifications can and do vary in different applications and actual performance may vary over time. All operating parameters, including "Typicals" must be validated for each customer application by customer's technical experts. SCILLC does not convey any license under its patent rights nor the rights of others. SCILLC products are not designed, intended, or authorized for use as components in systems intended for surgical implant into the body, or other applications intended to support or sustain life, or for any other application in which the failure of the SCILLC product could create a situation where personal injury or death may occur. Should Buyer purchase or use SCILLC products for any such unintended or unauthorized application, Buyer shall indemnify and hold SCILLC and its officers, employees, subsidiaries, affiliates, and distributors harmless against all claims, costs, damages, and expenses, and reasonable attorney fees arising out of, directly or indirectly, any claim of personal injury or death associated with such unintended or unauthorized use, even if such claim alleges that SCILLC was negligent regarding the design or manufacture of the part. SCILLC is an Equal Opportunity/Affirmative Action Employer. This literature is subject to all applicable copyright laws and is not for resale in any manner.

### PUBLICATION ORDERING INFORMATION

#### LITERATURE FULFILLMENT:

Literature Distribution Center for ON Semiconductor  
P.O. Box 5163, Denver, Colorado 80217 USA

Phone: 303-675-2175 or 800-344-3860 Toll Free USA/Canada

Fax: 303-675-2176 or 800-344-3867 Toll Free USA/Canada

Email: [orderlit@onsemi.com](mailto:orderlit@onsemi.com)

N. American Technical Support: 800-282-9855 Toll Free  
USA/Canada

Europe, Middle East and Africa Technical Support:

Phone: 421 33 790 2910

Japan Customer Focus Center

Phone: 81-3-5817-1050

ON Semiconductor Website: [www.onsemi.com](http://www.onsemi.com)

Order Literature: <http://www.onsemi.com/orderlit>

For additional information, please contact your local  
Sales Representative