

Parallax GPS Receiver Module

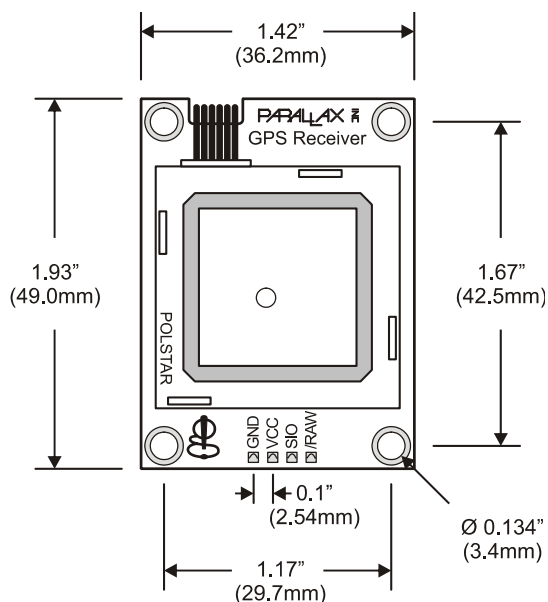

Introduction

Designed in cooperation with Grand Idea Studio (<http://www.grandideastudio.com/>), the Parallax Global Positioning System (GPS) Receiver Module is a fully integrated, low-cost unit complete with on-board patch antenna. Based around the Polstar (<http://www.polstargps.com/>) PMB-248, the GPS Receiver Module is a complete GPS solution in a very small footprint (1.92" long x 1.42" wide).

The GPS Receiver Module provides standard, raw NMEA0183 (National Marine Electronics Association) strings or specific user-requested data via the serial command interface, tracking of up to 12 satellites, and WAAS/EGNOS (Wide Area Augmentation System/European Geostationary Navigation Overlay Service) functionality for more accurate positioning results.

The Module provides current time, date, latitude, longitude, altitude, speed, and travel direction/heading, among other data, and can be used in a wide variety of hobbyist and commercial applications, including navigation, tracking systems, mapping, fleet management, auto-pilot, and robotics.

Module Highlights

- Fully-integrated, low-cost GPS receiver module with on-board, passive patch antenna
- Single-wire, 4800 baud Serial TTL interface to BASIC Stamp®, SX, Propeller, and other processors
- Provides either raw NMEA0183 strings or specific data requested via the command interface
- Requires single +5VDC supply @ 115mA (typical)
- 0.100" pin spacing for easy prototyping and integration

- Programmable Parallax SX/B microprocessor and open-source control firmware for advanced users (not supported by Parallax, but offered as a download from the Parallax web site)

Electronic Connections

Pin	Pin Name	Type	Function
1	GND	G	System ground. Connect to power supply's ground (GND) terminal.
2	VCC	P	System power, +5V DC input.
3	SIO	I/O	Serial communication (commands sent TO the Module and data received FROM the Module). Asynchronous, TTL-level interface, 4800bps, 8 data bits, no parity, 1 stop bit, non-inverted.
4	/RAW	I	Mode select pin. Active LOW digital input. Internally pulled HIGH by default. When the /RAW pin is unconnected, the default "Smart Mode" is enabled, wherein commands for specific GPS data can be requested and the results will be returned (see the "Command Structure" section for more details). When /RAW is pulled LOW, the Module will enter "Raw Mode" and will transmit standard strings, allowing advanced users to use the raw GPS data directly.

Note: Type: I = Input, O = Output, P = Power, G = Ground

The GPS Receiver Module can be integrated into any design using a minimum of three connections. Use the following circuit for connecting the GPS Receiver Module to the BASIC Stamp microcontroller:

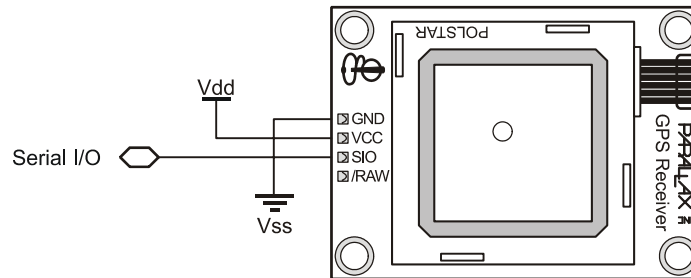

The on-board, four-pin header allows the GPS Receiver Module to be plugged into a solderless breadboard (on a Boe-Bot, for example). If the default "Smart Mode" is desired and the /RAW pin will be unused, the Module can be simply connected to its host with a standard three-pin servo extension cable.

The Module is designed to mount horizontally, so the antenna can face to the sky. Screw holes are located on each corner for more solid mounting if the user desires.

The Module must be used outdoors or with a clear view of the sky in order for it to fix on satellites - this is the nature of GPS and not a limitation of our product. With an unobstructed, clear view of the sky, GPS works anywhere in the world, 24 hours a day, seven days a week. Please note that some products, such as motors, computers, and wireless/RF devices, which emit high levels of magnetic field and interference, may prevent the Module from receiving the required GPS signals from the satellites and may cause the performance of the Module to decrease. Additionally, when using the Module in automobile applications, the optimal position for the Module is mounted on the rooftop of the vehicle. If the Module is to be used inside the car, ensure that the Module's antenna still has a clear view of the sky, such as by placing it on the dashboard, and is not blocked by any metal objects within the car.

For more information on GPS functionality, see the “GPS Technology Brief” section.

Status Indicators

The GPS Receiver Module contains a single red LED (light-emitting diode) to denote system status. The LED is located in the lower-right corner of the Module. A white overlay on the Module’s printed circuit board is used to reflect the light from the LED, making it easier for the user to see. The LED denotes two states of the Module:

- 1) **Blinking** (both fast and slow): Searching for satellites or no satellite fix acquired
- 2) **Solid**: Satellites successfully acquired (a minimum of three satellites is required before the Module will begin to transmit valid GPS data)

Upon power up of the GPS Receiver Module in a new location, the Module may take up to five minutes or more to acquire a fix on the necessary minimum number of four satellites. During this time, the red LED on the Module will blink. When enough satellites are acquired for the Module to function properly, the red LED will remain solid red. Due to a variety of conditions, the number of satellites may vary at any given time.

If the LED is OFF, there may be a problem. Please check your wiring and configuration of the Module.

Mode Selection

The /RAW pin allows user selection of the GPS Receiver Module’s two operating modes:

- **Smart Mode:** When the /RAW pin is pulled HIGH or simply left unconnected (the pin is internally pulled HIGH), the default “Smart Mode” is enabled, wherein commands for specific GPS data can be requested and the results will be returned. See the “Communication Protocol” section for more details.
- **Raw Mode:** When the /RAW pin is pulled LOW, “Raw Mode” is enabled in which the Module will transmit standard NMEA0183 v2.2 strings (GGA, GSV, GSA, and RMC), allowing advanced users to use the raw GPS data directly. For more information on NMEA0183 data, see the “GPS Technology Brief” section.

In either mode, data is transmitted at 4800bps, 8 data bits, no parity, 1 stop bit, non-inverted, TTL-level.

Communication Protocol (for use in “Smart Mode” only)

Implementation and usage of the GPS Receiver Module is straightforward. A BASIC Stamp 2 code example is included at the end of this documentation.

The GPS Receiver Module is controlled by the host via an easy-to-use, TTL-level, asynchronous serial communications interface. The command structure and communication is compatible with Parallax’s AppMod serial protocol. The single SIO pin transfers commands sent TO the Module and data received FROM the Module. All communication is at 4800bps, 8 data bits, no parity, 1 stop bit, non-inverted.

To send a command to the GPS Receiver Module, the user must first send the header string, which is “!GPS” without the quotes, followed by the specific command byte of their choice.

Each command consists of a single byte in hexadecimal. Depending on the command, a specific number of data bytes will be returned. The complete command list and returned variables are as follows:

Cmd	Constant	Description	Returned Bytes	Variables (1 Byte Each Unless Noted)
0x00	GetInfo	GPS Receiver Module version	2	Hardware, Firmware
0x01	GetValid	Check validity of data string	1	0 = Not Valid, 1 = Valid
0x02	GetSats	Number of acquired satellites (12 maximum)	1	
0x03	GetTime	Time (UTC/Greenwich Mean Time)	3	Hours, Minutes, Seconds
0x04	GetDate	Date (UTC/Greenwich Mean Time)	3	Month, Day, Year
0x05	GetLat	Latitude	5	Degrees, Minutes, Fractional Minutes (Word), Direction (0 = N, 1 = S)
0x06	GetLong	Longitude	5	Degrees, Minutes, Fractional Minutes (Word), Direction (0 = E, 1 = W)
0x07	GetAlt	Altitude above mean-sea-level (in tenths of meters, 65535 maximum)	2	Altitude (Word)
0x08	GetSpeed	Speed (in tenths of knots)	2	Speed (Word)
0x09	GetHead	Heading/direction of travel (in tenths of degrees)	2	Heading (Word)

Other Specifications

- The navigation update rate of the GPS Receiver Module is once per second.
- High sensitivity (-152 dBm for tracking and -139 dBm for acquisition).
- The Module contains a built-in rechargeable battery for memory and real-time clock back-up.
- On average, the Module has a +/-5 meter position accuracy and a +/-0.1 meter per second velocity accuracy.

Electrical Characteristics

Absolute Maximum Ratings

Condition	Value
Operating Temperature	-40°C to +85°C
Storage Temperature	-55°C to +100°C
Supply Voltage (V _{CC})	+4.5V to +5.5V
Ground Voltage (V _{SS})	0V
Voltage on any pin with respect to V _{SS}	-0.6V to +(V _{CC} +0.6)V

NOTICE: Stresses above those listed under “Absolute Maximum Ratings” may cause permanent damage to the device. This is a stress rating only and functional operation of the device at those or any other conditions above those indicated in the operation listings of this specification is not implied. Exposure to maximum rating conditions for extended periods may affect device reliability.

DC Characteristics

At $V_{CC} = +5.0V$ and $T_A = 25^{\circ}C$ unless otherwise noted

Parameter	Symbol	Test Conditions	Specification			Unit
			Min.	Typ./Avg.	Max.	
Supply Voltage	V_{CC}	---	4.5	5.0	5.5	V
Supply Current, Active	I_{CC}	---	80	115	135	mA

GPS Technology Brief

Some material in this section is based on information provided by the Global Position System FAQ (<http://www.gpsy.com/gpsinfo/gps-faq.txt>)

Developed and operated by the United States government, GPS (Global Positioning System) is a worldwide radio-navigation system formed by a constellation of 24 satellites and their ground stations. With an unobstructed, clear view of the sky, GPS works anywhere in the world, 24 hours a day, seven days a week.

The Global Positioning System consists of three interacting components:

- 1) **The Space Segment** -- satellites orbiting the earth.
- 2) **The Control Segment** -- the control and monitoring stations run by the United States Department of Defense (not discussed in this documentation).
- 3) **The User Segment** -- the GPS signal receivers owned by civilians and military.

The space segment consists of a constellation of 24 active satellites (and one or more in-orbit spares) orbiting the earth every 12 hours. Four satellites are located in each of six orbits and will be visible from any location on each 95 percent of the time. The orbits are distributed evenly around the earth, and are inclined 55 degrees from the equator. The satellites orbit at an altitude of about 11,000 nautical miles.

Each satellite transmits two signals: L1 (1575.42 MHz) and L2 (1227.60 MHz). The L1 signal is modulated with two pseudo-random noise signals - the protected (P) code, and the course/acquisition (C/A) code. The L2 signal only carries the P code. Civilian navigation receivers only use the C/A code on the L1 frequency. Each signal from each satellite contains a repeating message, indicating the position and orbital parameters of itself and the other satellites (almanac), a bill of health for the satellites (health bit), and the precise atomic time.

The receiver measures the time required for the signal to travel from the satellite to the receiver, by knowing the time that the signal left the satellite, and observing the time it receives the signal, based on its internal clock. If the receiver had a perfect clock, exactly in sync with those on the satellites, three measurements, from three satellites, would be sufficient to determine position in three dimensions via triangulation. However, that is not the case, so a fourth satellite is needed to resolve the receiver clock error. With four satellites, a GPS receiver can provide very accurate clock (time, date) and position information (latitude, longitude, altitude, speed, travel direction/heading).

Note that position data and accuracy are affected or degraded by the satellite geometry, electromagnetic interference, and multipath, an unpredictable set of reflections and/or direct waves each with its own degree of attenuation and delay. Primarily due to satellite geometry, measuring

altitude using GPS may introduce an accuracy error of 1.5 times the receiver's position accuracy (in the case of our GPS Receiver Module, this corresponds to about +/-20 meters in the vertical direction).

GPS signals work in the microwave radio band. They can pass through glass, but are absorbed by water molecules (wood, heavy foliage) and reflect off concrete, steel, and rock. This means that GPS units have trouble operating in rain forests, urban jungles, deep canyons, inside automobiles and boats, and in heavy snowfall - among other things. These environmental obstacles degrade positional accuracy or make it impossible to get a fix on your location.

Most GPS receivers output a stream of data so that it can be used and interpreted by other devices. The most common format (and used by our GPS Receiver Module in "Raw Mode") is NMEA0183 (National Marine Electronics Association, <http://www.nmea.org/>), developed for data communications between marine instruments. Some receivers also have proprietary data formats which are used (in the case of navigation receivers) to transfer waypoint lists, track logs, and other data between the GPS and a computer. Such proprietary formats are not covered by the NMEA standard.

The NMEA0183 is provided as a series of comma-delimited ASCII strings, each preceded with an identifying header. The data is transmitted as a 4800bps string of 8-bit ASCII characters. Thus, any microcontroller with a serial port can extract data from a GPS module. But, modules do not produce "plain text" location information. Instead, they create standardized "sentences," such as:

```
$GPGGA,170834,4124.8963,N,08151.6838,W,1,05,1.5,280.2,M,-34.0,M,,,*75
$GPGSA,A,3,19,28,14,18,27,22,31,39,,,,,1.7,1.0,1.3*34
$GPGSV,3,2,11,14,25,170,00,16,57,208,39,18,67,296,40,19,40,246,00*74
$GPRMC,220516,A,5133.82,N,00042.24,W,173.8,231.8,130694,004.2,W*70
```

Programmers can parse these strings to obtain their desired information, including time, date, latitude, longitude, speed, and altitude. For more information on NMEA0183 sentence information, visit <http://home.mira.net/~gnb/gps/nmea.html>.

The "Smart Mode" of the Parallax GPS Receiver Module will receive commands from the user and automatically parse the necessary NMEA0183 strings to calculate the desired information for the user. Using the example code provided at the end of this document will output parsed data in the following format (this screenshot was taken while driving through Lone Pine, California):

Parallax GPS Receiver Module Test Application

```
-----
Hardware Version: 1.0
Firmware Version: 1.0

Signal Valid: Yes
Acquired Satellites: 8

Local Time: 23:28:45
Local Date: 09 MAR 2006

Latitude: 036° 35' 55.3" N ( 36.5986 )
Longitude: 118° 03' 35.6" W (-118.0599 )
Altitude: 1143.2 meters ( 3750.6 feet )
Speed: 33.8 Knots ( 38.8 MPH )
Direction of Travel: 338.1°
```

There are three standard notations for displaying longitude and latitude data:

- **GPS Coordinates** (degrees, minutes, and fractional minutes), ex: 36 degrees, 35.9159 minutes
- **DDMMSS** (degrees, minutes, seconds), ex: 36 degrees, 35 minutes, 55.3 seconds
- **Decimal Degrees**, ex: 36.5986 degrees

In "Smart Mode," the Parallax GPS Receiver Module transmits latitude and longitude data to the user in GPS Coordinate format (degrees, minutes, and fractional minutes, see the "Communication Protocol" section for more details). Conversion to the two other notations, DDMMSS (degrees, minutes, second) and Decimal Degrees, is trivial and demonstrated in the example code below.

To graphically display your GPS position using Google Maps (in map, satellite, or hybrid view), simply go to <http://maps.google.com/> and enter in your decimal coordinates in the "Search" field (for example, "36.5986, -118.0599" without the quotes).

To graphically display a track or series of waypoints, GPS Visualizer (<http://www.gpsvisualizer.com/>) is a free, easy-to-use online utility that creates maps and profiles from GPS data. GPS Visualizer can read data files from many different sources, including raw NMEA strings (such as those captured directly from the Parallax GPS Receiver Module in "Raw Mode") or tab-delimited or comma-separated text of relevant GPS data.

Some additional resources and articles on GPS can be found here:

- Where in the World is my BASIC Stamp?, Jon Williams, The Nuts and Volts of BASIC Stamps (Volume 3), <http://www.parallax.com/dl/docs/cols/nv/vol3/col/nv83.pdf>
- Stamping on Down the Road, Jon Williams, The Nuts and Volts of BASIC Stamps (Volume 4), <http://www.parallax.com/dl/docs/cols/nv/vol4/col/nv103.pdf>

Example Code (BASIC Stamp 2)

```

' =====
'
' File..... GPSDemoV1.1.BS2
' Purpose... Demonstrates features of the Parallax GPS Receiver Module
' Author.... (c) Grand Idea Studio, Inc. [www.grandideastudio.com]
' E-mail.... support@parallax.com
' Updated... 04 Oct 2006 (by Parallax Tech Support)
'
'   {$STAMP BS2}
'   {$PBASIC 2.5}
'
' =====
'
' -----[ Program Description ]-----
'
' This program demonstrates the capabilities of the Parallax GPS Receiver
' Module.
'
' Before running this demo, ensure that the /RAW pin is left unconnected
' or pulled HIGH to enable "smart" mode, in which the GPS Receiver Module
' will accept commands and return the requested GPS data.
'
' For an application that requires constant monitoring of multiple GPS
' data components, it is recommended to use the "raw" mode of the GPS
' Receiver Module by pulling the /RAW Pin LOW. In this mode, the module
' will transmit a constant stream of raw NMEA0183 data strings, which can

```

Parallax GPS Receiver Module * Revision 1.1

' then be parsed by the host application.

' -----[I/O Definitions]-----

Sio PIN 15 ' connects to GPS Module SIO pin

' -----[Constants]-----

T4800 CON 188
 Open CON \$8000

 Baud CON Open | T4800 ' Open mode to allow daisy chaining

 MoveTo CON 2 ' DEBUG positioning command
 ClrRt CON 11 ' clear line right of cursor
 FieldLen CON 22 ' length of debug text

 EST CON -5 ' Eastern Standard Time
 CST CON -6 ' Central Standard Time
 MST CON -7 ' Mountain Standard Time
 PST CON -8 ' Pacific Standard Time

 EDT CON -4 ' Eastern Daylight Time
 CDT CON -5 ' Central Daylight Time
 MDT CON -6 ' Mountain Daylight Time
 PDT CON -7 ' Pacific Daylight Time

 UTCfix CON PST ' for San Diego, California

 DegSym CON 176 ' degrees symbol for report
 MinSym CON 39 ' minutes symbol
 SecSym CON 34 ' seconds symbol

' GPS Module Commands

GetInfo CON \$00
 GetValid CON \$01
 GetSats CON \$02
 GetTime CON \$03
 GetDate CON \$04
 GetLat CON \$05
 GetLong CON \$06
 GetAlt CON \$07
 GetSpeed CON \$08
 GetHead CON \$09

' -----[Variables]-----

char VAR Byte
 workVal VAR Word ' for numeric conversions
 eeAddr VAR workVal ' pointer to EE data

 ver_hw VAR Byte
 ver_fw VAR Byte

 valid VAR Byte ' signal valid? 0 = not valid, 1 = valid
 sats VAR Byte ' number of satellites used in positioning calculations

 tmHrs VAR Byte ' time fields
 tmMins VAR Byte
 tmSecs VAR Byte

 day VAR Byte ' day of month, 1-31
 month VAR Byte ' month, 1-12
 year VAR Byte ' year, 00-99

 degrees VAR Byte ' latitude/longitude degrees
 minutes VAR Byte ' latitude/longitude minutes
 minutesD VAR Word ' latitude/longitude decimal minutes
 dir VAR Byte ' direction (latitude: 0 = N, 1 = S, longitude: 0 = E, 1 = W)

 heading VAR Word ' heading in 0.1 degrees
 alt VAR Word ' altitude in 0.1 meters
 speed VAR Word ' speed in 0.1 knots

' -----[EEPROM Data]-----

NotValid DATA "No", 0
 IsValid DATA "Yes", 0

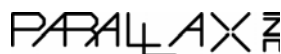

```
DaysInMon      DATA    31,28,31,30,31,30,31,31,30,31,30,31
MonNames       DATA    "JAN",0,"FEB",0,"MAR",0,"APR",0,"MAY",0,"JUN",0
                DATA    "JUL",0,"AUG",0,"SEP",0,"OCT",0,"NOV",0,"DEC",0
```

' -----[Initialization]-----

```
Initialize:
PAUSE 250 ' let DEBUG open
DEBUG CLS ' clear the screen
DEBUG "Parallax GPS Receiver Module Test Application", CR,
      "-----"
```

```
Draw_Data_Labels:
DEBUG MoveTo, 0, 3, "    Hardware Version: "
DEBUG MoveTo, 0, 4, "    Firmware Version: "
DEBUG MoveTo, 0, 6, "    Signal Valid: "
DEBUG MoveTo, 0, 7, "    Acquired Satellites: "
DEBUG MoveTo, 0, 9, "    Local Time: "
DEBUG MoveTo, 0, 10, "    Local Date: "
DEBUG MoveTo, 0, 12, "    Latitude: "
DEBUG MoveTo, 0, 13, "    Longitude: "
DEBUG MoveTo, 0, 14, "    Altitude: "
DEBUG MoveTo, 0, 15, "    Speed: "
DEBUG MoveTo, 0, 16, "    Direction of Travel: "
```

' -----[Program Code]-----

```
Main:
GOSUB Get_Info
GOSUB Get_Valid
GOSUB Get_Sats
GOSUB Get_TimeDate
GOSUB Get_Lat
GOSUB Get_Long
GOSUB Get_Alt
GOSUB Get_Speed
GOSUB Get_Head
GOTO Main
```

' -----[Subroutines]-----

```
Get_Info:
SEROUT Sio, Baud, ["!GPS", GetInfo]
SERIN Sio, Baud, 3000, No_Response, [ver_hw, ver_fw]
DEBUG MoveTo, FieldLen, 3, HEX ver_hw.HIGHNIB, ".", HEX ver_hw.LOWNIB
DEBUG MoveTo, FieldLen, 4, HEX ver_fw.HIGHNIB, ".", HEX ver_fw.LOWNIB
RETURN
```

```
Get_Valid:
SEROUT Sio, Baud, ["!GPS", GetValid]
SERIN Sio, Baud, 3000, No_Response, [valid]

DEBUG MoveTo, FieldLen, 6 ' was the signal valid?
LOOKUP valid, [NotValid, IsValid], eeAddr ' get answer from EE
GOSUB Print_Z_String ' print it
DEBUG ClrRt ' clear end of line
IF (valid = 0) THEN signal_Not_Valid
RETURN
```

```
Get_Sats:
SEROUT Sio, Baud, ["!GPS", GetSats]
SERIN Sio, Baud, 3000, No_Response, [sats]
DEBUG MoveTo, FieldLen, 7, DEC sats
RETURN
```

```
Get_TimeDate:
SEROUT Sio, Baud, ["!GPS", GetTime]
SERIN Sio, Baud, 3000, No_Response, [tmHrs, tmMins, tmSecs]

SEROUT Sio, Baud, ["!GPS", GetDate]
SERIN Sio, Baud, 3000, No_Response, [day, month, year]
```

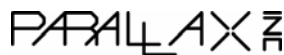

Parallax GPS Receiver Module * Revision 1.1

```
GOSUB Correct_Local_Time_Date

DEBUG MoveTo, FieldLen, 9, DEC2 tmHrs, ":", DEC2 tmMins, ":", DEC2 tmSecs

DEBUG MoveTo, FieldLen, 10, DEC2 day, " "
eeAddr = (month - 1) * 4 + MonNames      ' get address of month name
GOSUB Print_Z_String                    ' print it
DEBUG " 20", DEC2 year
RETURN

' -----

Get_Lat:
SEROUT Sio, Baud, ["!GPS", GetLat]
SERIN  Sio, Baud, 3000, No_Response, [degrees, minutes, minutesD.HIGHBYTE, minutesD.LOWBYTE, dir]

' convert decimal minutes to tenths of seconds
workVal = minutesD ** $0F5C ' minutesD * 0.06

DEBUG MoveTo, FieldLen, 12, DEC3 degrees, DegSym, " ", DEC2 minutes, MinSym, " "
DEBUG DEC2 (workVal / 10), ".", DEC1 (workVal // 10), SecSym, " "
DEBUG "N" + (dir * 5)

' convert to decimal format, too
workVal = (minutes * 1000 / 6) + (minutesD / 60)
DEBUG " (", " " + (dir * 13), DEC degrees, ".", DEC4 workVal, " ) "
RETURN

' -----

Get_Long:
SEROUT Sio, Baud, ["!GPS", GetLong]
SERIN  Sio, Baud, 3000, No_Response, [degrees, minutes, minutesD.HIGHBYTE, minutesD.LOWBYTE, dir]

' convert decimal minutes to tenths of seconds
workVal = minutesD ** $0F5C ' minutesD * 0.06

DEBUG MoveTo, FieldLen, 13, DEC3 degrees, DegSym, " ", DEC2 minutes, MinSym, " "
DEBUG DEC2 (workVal / 10), ".", DEC1 (workVal // 10), SecSym, " "
DEBUG "E" + (dir * 18)

' convert to decimal format, too
workVal = (minutes * 1000 / 6) + (minutesD / 60)
DEBUG " (", " " + (dir * 13), DEC degrees, ".", DEC4 workVal, " ) "
RETURN

' -----

Get_Alt:
SEROUT Sio, Baud, ["!GPS", GetAlt]
SERIN  Sio, Baud, 3000, No_Response, [alt.HIGHBYTE, alt.LOWBYTE]

DEBUG MoveTo, FieldLen, 14, DEC (alt / 10), ".", DEC1 (alt // 10), " meters "
workVal = alt / 10 ' remove tenths from altitude
' convert altitude from meters to feet
workVal = (workVal * 3) + (workVal ** $47E5) ' 1 meter = 3.2808399 feet
DEBUG " ( ", DEC workVal, " feet ) "

RETURN

' -----

Get_Speed:
SEROUT Sio, Baud, ["!GPS", GetSpeed]
SERIN  Sio, Baud, 3000, No_Response, [speed.HIGHBYTE, speed.LOWBYTE]

DEBUG MoveTo, FieldLen, 15, DEC (speed / 10), ".", DEC1 (speed // 10), " Knots "

' convert speed from knots to MPH
workVal = speed + (speed ** $2699) ' 1 knot = 1.1507771555 MPH
DEBUG " ( ", DEC (workVal / 10), ".", DEC1 (workVal // 10), " MPH ) "
RETURN

' -----

Get_Head:
SEROUT Sio, Baud, ["!GPS", GetHead]
SERIN  Sio, Baud, 3000, No_Response, [heading.HIGHBYTE, heading.LOWBYTE]

IF speed = 0 THEN
  DEBUG MoveTo, FieldLen, 16, "N/A "

```

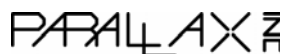

```

ELSE
  DEBUG MoveTo, FieldLen, 16, DEC (heading / 10), ".", DEC1 (heading // 10), DegSym, " "
ENDIF
RETURN

' -----

No_Response:
  DEBUG MoveTo, 0, 18, "Error: No response from GPS Receiver Module"
  PAUSE 5000
  GOTO Initialize

' -----

Signal_Not_Valid:
  DEBUG MoveTo, FieldLen, 7, "?", ClrRt ' clear all fields
  DEBUG MoveTo, FieldLen, 9, "?", ClrRt
  DEBUG MoveTo, FieldLen, 10, "?", ClrRt
  DEBUG MoveTo, FieldLen, 12, "?", ClrRt
  DEBUG MoveTo, FieldLen, 13, "?", ClrRt
  DEBUG MoveTo, FieldLen, 14, "?", ClrRt
  DEBUG MoveTo, FieldLen, 15, "?", ClrRt
  DEBUG MoveTo, FieldLen, 16, "?", ClrRt
  GOTO Main

' -----

' adjust date for local position

Correct_Local_Time_Date:
  workVal = tmHrs + UTCfix ' add UTC offset
  IF (workVal < 24) THEN Adjust_Time ' midnight crossed?
  workVal = UTCfix ' yes, so adjust date
  BRANCH workVal.BIT15, [Location_Leads, Location_Lags]

Location_Leads:
  day = day + 1 ' east of Greenwich
  eeAddr = DaysInMon * (month - 1) ' no, move to next day
  READ eeAddr, char ' get days in month
  IF (day <= char) THEN Adjust_Time ' in same month?
  month = month + 1 ' no, move to next month
  day = 1 ' first day
  IF (month < 13) THEN Adjust_Time ' in same year?
  month = 1 ' no, set to January
  year = year + 1 // 100 ' add one to year
  GOTO Adjust_Time

Location_Lags:
  day = day - 1 ' west of Greenwich
  IF (day > 0) THEN Adjust_Time ' adjust day
  month = month - 1 ' same month?
  IF (month > 0) THEN Adjust_Time ' same year?
  month = 1 ' no, set to January
  eeAddr = DaysInMon * (month - 1)
  READ eeAddr, day ' get new day
  year = year + 99 // 100 ' set to previous year

Adjust_Time:
  tmHrs = tmHrs + (24 + UTCfix) // 24 ' localize hours
  RETURN

' -----

' Print Zero-terminated string stored in EEPROM
' -- eeAddr - starting character of string

Print_Z_String:
  READ eeAddr, char ' get char from EE
  IF (char = 0) THEN Print_Z_String_Done ' if zero, we're done
  DEBUG char ' print the char
  eeAddr = eeAddr + 1 ' point to the next one
  GOTO Print_Z_String

Print_Z_String_Done:
  RETURN

' -----

```

High Sensitivity GPS Module

- Built-in SiRFstarIII chipsets receivers give unparalleled GPS performance and precision. 20 parallel satellite-tracking channels for fast acquisition and reacquisition.
- Built-in Sony CXD2951GA-4 chipsets receivers give the better Time-To-First-Fix (TTFF) for positioning. 12 parallel satellite-tracking channels for fast acquisition and reacquisition.
- Built-in WAAS/EGNOS Demodulator.
- Low power consumption and ultra mini size only 32 x 32mm.
- Built-in rechargeable battery for memory and RTC backup
- Support NMEA0183 v2.2 data protocol.
- Enhanced algorithms providing superior navigation performance in urban, canyon and foliage environments.
- For Car Navigation, Marine Navigation, Fleet Management, AVL and Location-Based Services, Auto Pilot,
- Personal Navigation or touring devices, Tracking devices/systems and Mapping devices application.

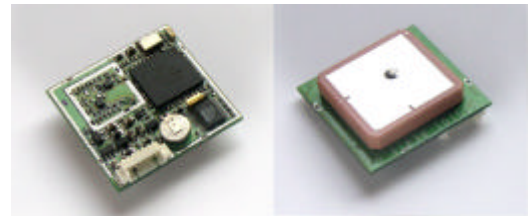

SPECIFICATIONS

	PMB-648	PMB-248
GPS IC	SiRFstarIII	SonyCXD2951GA-4
Receiver:	Tracking upto 20 satellites L1, 1575.42MHz, C/Acode	Tracking upto 12 satellites L1, 1575.42MHz, C/Acode
Accuracy:	Position: 2DRMS approximately 5m, WAAS support Velocity: 0.1m/s without SA imposed. Time: ± 5µsec	Position: 2DRMS approximately 2m, WAAS SUPPORT. Velocity: 0.1m/sec without SA imposed. Time: ± 5µsec
Acquisition Time:	Cold Start: 42sec (Average) Warm Start: 38sec (Average) Hot Start: 1sec (Min.)	Cold start: 45sec (Average) Warm start: 35sec (Average) Hot start: 2sec (Min.)
Sensitivity:	Acquisition: -148dBm Tracking: -159dBm	Acquisition: -139dBm Tracking: -152dBm
Dynamics:	Altitude: 18000m (Max.) Velocity: 515m/s (Max.) Acceleration: ±g (Max.)	Altitude: 18,000m (Max.) Velocity: 500m/sec (Max.) Acceleration: ±g (Max.)
Navigation update rate:	Once per second	Once per second
Serial Port:	TTL and RS-232	TTL and RS-232
Baud Rate:	4800 bps (Optional 9600, 19300, 38400 bps)	4800 bps (optional 9600 bps, 19200 bps, 38400 bps)
Output Message:	NMEA0183 V2.2 GGA, GSV, GSA, RMC (optional VTG, GLL)	NMEA0183 V2.2 GGA, GSV, GSA, RMC (optional VTG, GLL)
Datum:	WGS84	WGS 84
Power supply:	DC 3.3V - 5V	DC 3.3V - 5V
Power Consumption:	Typical 65mA @ 5V	Typical 80mA @ 5V.
LED Function:	Power on/off and Navigation	Power on/off and Navigation
Operating Temp.:	-40 ~ +85	-40 ° ~ +85 °C
Storage Temp.:	-40 ~ +100	-40 ° ~ +100 °C
Humidity:	5% - 95%	5% - 95%
Antenna Type:	Built-in Patch antenna	Built-in Patch Antenna.

