

Weld Immune Proximity Sensors

Weld Immune Cylinder Position Sensors

Inductive Cylinder Position Sensors

- 4-Wire DC (NPN and PNP)
- 2-Wire AC/DC
- Weld immune
- 250, 1000, and 3000 psi designs



Inductive Cylinder Position Sensors

Pepperl+Fuchs offers four standard inductive cylinder position sensor designs for operation within a pressurized environment while maintaining environmental sealing. Each type is offered in a variety of probe lengths and connectivity options ensuring reliable end-of-stroke sensing in hydraulic or pneumatic cylinders. All models offer short circuit/overload protection, weld immunity.

| | Pressure Rating (psi) | Probe Diameter (mm) | Flange Thickness (mm) | Description |
|---|-----------------------|---------------------|-----------------------|--|
| C-Series  | 250 | 11.5 | 14.3 | Canister-style swivel housing, 3/8"-18NPT probe thread. 360° rotation; suited for robotic machinery. |
| F-Series  | 1000 | 11.5 | 7.0 | Flange mount |
| D-Series  | 3000 | 12.7 | 11.0 | Flange mount |
| PD-Series  | 3000 | 12.7 | 15.0 | Captive, narrow flange |



See pages 827-874 for cordsets



See pages 885-892 for accessories

Testing and Definitions (All Series)

Invasive Cylinder Position Sensor: An inductive proximity sensor that verifies end-of-stroke in hydraulic or pneumatic cylinders. Sensors are classified according to their mechanical form and pressure rating. P+F products meet electrical and mechanical requirements of standard inductive proximity sensors in addition to the application-specific criteria.

P+F cylinder position sensors are capable of sensing/operation within pressurized environments while maintaining a fluid-tight (hydraulic) or air-tight (pneumatic) seal.

Pressure Ratings

Nominal Pressure Rating: P+F cylinder position sensors specify a nominal/operational pressure rating - typically 250, 1000, 3000.

Proof Testing: P+F cylinder position sensor designs are proof tested to 1.5 times the nominal pressure rating for a minimum of 1,000,000 dynamic pressure cycles. Sensors must retain normal functionality at the conclusion of proof testing. No leakage of air or hydraulic fluid around the mounting flange or into the sensor is permissible.

Burst Rating: P+F sensors are capable of withstanding static pressures as defined below for a period of 1 minute, without loss of structural or seal integrity:

- 3 times the nominal pressure rating for 250 psi, 1000 psi and 3000 psi rated models

Pressurization rate is no faster than 300 psi/second. Sensor is not required to maintain normal functionality at the conclusion of burst testing, but no external leakage of air or hydraulic fluid around the flange or housing is permissible.

EMI and RFI Immunity: P+F cylinder switches meet EMI and RFI test requirements as defined by EN 60947-5-2. All P+F cylinder switches are CE compliant.

Sensor Selection

The Probe Length: The probe length equals the distance from the cylinder mounting surface to the probe sensing face.

The Target: Depending upon the cylinder type and sensor position, the target will be either the cylinder cushion or rod-end inside the cylinder. The target material is steel, with dimensions specified by cylinder manufacturer.

The Sensing Range: The sensing range is precalibrated to 2.0mm (steel target). To allow for vibration, variances in target shape and physical wear the specified sensor-to-target clearance must be between 0.60mm (0.025in.) and 1.20mm (0.047in.).

Target / No Target Differential: The height differential between cushion and rod shall be greater than 1.58 X Sn. This ensures the sensor will switch states when the cushion is removed.

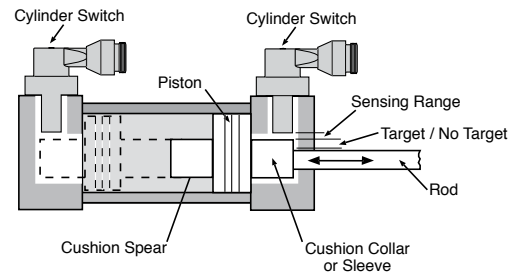

Mounting (C Series)

Probe Through-Hole:

Standard probe hole ports are tapped with size 3/8" NPT threading for C series. The minimum probe through-hole diameter is 0.560".

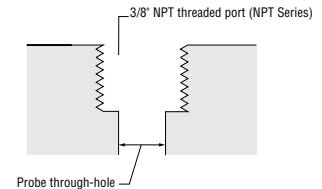

Mounting (F, D, and PD Series)

NPT Type Mounting Holes:

- 1000 and 3000 psi NPT Types: Thread shall be 1/4" - 20. Minimum thread engagement depth is 0.250". Hole spacing is 35mm center to center.

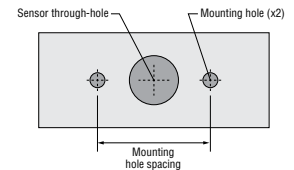





Mounting Screws:

- Standard 1000 and 3000 psi models use two, self-locking 1/4" - 20 socket head cap screws (provided). Recommended tightening torque: 150in. lb.



Important: When using spacers, make certain to maintain the 0.250" minimum mounting screw thread engagement.

Weld Immune Proximity Sensors

| Technical Specifications | 4-Wire DC | 2-Wire AC/DC |
|---------------------------------------|--|---|
| SUPPLY VOLTAGE | 10-30 VDC | 20-250 VAC/VDC |
| LOAD CURRENT (I _L) | 200 mA max. | 300 mA max. |
| OUTPUT | NPN and PNP normally open | Normally open |
| VOLTAGE DROP AT I _L (MAX.) | ≤ 2 VDC | ≤ 7 VDC |
| INRUSH CURRENT (MAX.) | — | 3 A |
| HYSTERESIS | 10-20% (15% typical) | 10-20% (15% typical) |
| SHORT CIRCUIT AND OVERLOAD PROTECTION | Yes | Yes |
| REVERSE POLARITY PROTECTED | Yes | Yes |
| LED INDICATION | See dimension drawings | See dimension drawings |
| HOUSING MATERIAL | Aluminum | Aluminum |
| STANDARDS | EN 60947-5-2 | EN 60947-5-2 |
| ENVIRONMENTAL PROTECTION | IP67 | IP67 |
| WELD FIELD IMMUNITY | ≤ 100 mT | ≤ 250 mT (AC fields) ≤ 100 mT (DC fields) |
| AMBIENT TEMPERATURE | -14°F to +158°F (-25°C to +70°C) | -14°F to +158°F (-25°C to +70°C) |
| APPROVALS | CE   | CE   |



Wiring Diagrams

4-Wire DC



Quick Disconnect

Note: Wiring diagrams show quick disconnect pin numbers.

V1 Type

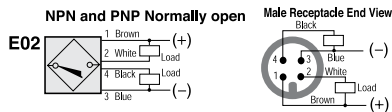

V95 Type

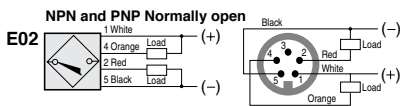

2-Wire ACDC



Quick Disconnect

Note: Wiring diagrams show quick disconnect pin numbers.

V12 Type

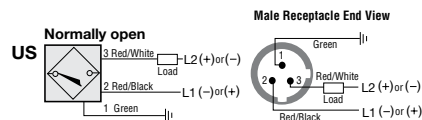

V93 Type

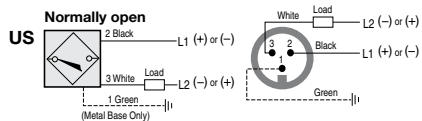

Selecting a Cylinder Switch

Option 1: Specifying Standard Cylinder Switches:

The selection charts display all "standard" cylinder sensors, from 250 psi to 3000 psi. By choosing a sensor from this chart, you are assured the best product availability.

Option 2: Non-standard Cylinder Switches:

If non-standard probe lengths are required, P+F offers two alternatives. (1) For "F," "D" and "PD" series designs, spacers are offered that can be used to shorten the effective probe length. "C" series models cannot use spacers. (2) Customer-specific designs. Contact your factory representative for details.

Option 3: Specifying a Custom "C," "F," "D" or "PD" Cylinder Switch (minimum quantities apply):

The minimum possible probe length for "C," "F," "D" and "PD" styles is 0.625", and the maximum is 4.565". Custom probe lengths must be specified in increments of 0.010" (ie. 0.625", 0.635", etc). Call a P+F Applications Engineer for details.

Option 4: Selecting a spacer- "F," "D" and "PD" Series:

Custom spacers can be used to shorten the effective probe length. A Viton durometer 90 O-ring seals the sensor-spacer junction, preventing fluid or air leakage. Consult factory for assistance in selecting spacers.

Weld Immune Proximity Sensors

Example: Cylinder requires a 3000 psi “D” series cylinder switch with a 0.625” probe length. Reviewing the chart, we see 1.025” is the closest available standard probe length (NJ2-D-E02-1.025-V1.) To create a 0.625” probe length, a 0.400” spacer is required ($1.025” - 0.625” = 0.400”$.) By installing an NJ2-D-E02-1.025-V1 with a 0.400” spacer, the desired 0.625” probe length is created.

Note: Spacers may necessitate longer mounting screws than those provided. Refer to “Mounting” section (page 169) to verify proper thread engagement depth.

NOTE: Spacers can be custom manufactured to your exact specifications. See chart.

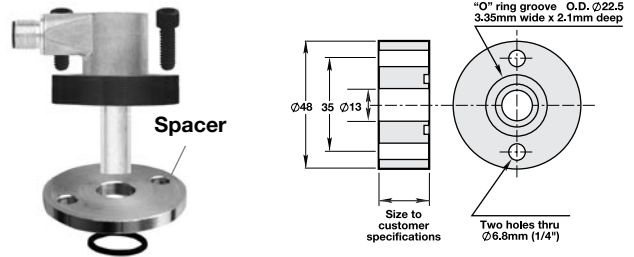

Spacer Thickness

| | Inches | Millimeters |
|------------|--------|-------------|
| Minimum | 0.160 | 4.06 |
| Maximum | 1.750 | 44.5 |
| Increments | 0.005 | 0.13 |

C-Series Models

| Model Number | Pressure Rating (psi) | Range (mm) | Probe Length [in. (mm)] | Electrical Output | Switching Frequency | Quick Disconnect | Dwg. No. |
|--------------------|-----------------------|------------|-------------------------|-------------------|---------------------|------------------|----------|
| NJ2-C-E02-0.915-V1 | 250 | 2 | 0.915 (23.2) | NPN & PNP N.O. | 20Hz | M12 Micro | 1 |
| NJ2-C-E02-1.025-V1 | 250 | 2 | 1.025 (26.0) | NPN & PNP N.O. | 20Hz | M12 Micro | 1 |
| NJ2-C-E02-2.062-V1 | 250 | 2 | 2.062(52.4) | NPN & PNP N.O. | 20Hz | M12 Micro | 1 |

F-Series Models

| Model Number | Pressure Rating (psi) | Range (mm) | Probe Length [in. (mm)] | Electrical Output | Switching Frequency | Quick Disconnect | Dwg. No. |
|--------------------|-----------------------|------------|-------------------------|-------------------|---------------------|------------------|----------|
| NJ2-F-E02-1.025-V1 | 1000 | 2 | 1.025 (26.0) | NPN & PNP N.O. | 20Hz | M12 Micro | 2 |
| NJ2-F-E02-1.250-V1 | 1000 | 2 | 1.250(31.7) | NPN & PNP N.O. | 20Hz | M12 Micro | 2 |
| NJ2-F-E02-2.062-V1 | 1000 | 2 | 2.062(52.4) | NPN & PNP N.O. | 20Hz | M12 Micro | 2 |
| NJ2-F-US-1.025-V93 | 1000 | 2 | 1.025 (26.0) | N.O. AC/DC | 20Hz | 7/8"-16 Mini AC | 2 |
| NJ2-F-US-1.250-V93 | 1000 | 2 | 1.250(31.7) | N.O. AC/DC | 20Hz | 7/8"-16 Mini AC | 2 |
| NJ2-F-US-2.062-V93 | 1000 | 2 | 2.062(52.4) | N.O. AC/DC | 20Hz | 7/8"-16 Mini AC | 2 |

D-Series Models

| Model Number | Pressure Rating (psi) | Range (mm) | Probe Length [in. (mm)] | Electrical Output | Switching Frequency | Quick Disconnect | Dwg. No. |
|--------------------|-----------------------|------------|-------------------------|-------------------|---------------------|------------------|----------|
| NJ2-D-E02-1.025-V1 | 3000 | 2 | 1.025 (26.0) | NPN & PNP N.O. | 20Hz | M12 Micro | 3 |
| NJ2-D-E02-1.250-V1 | 3000 | 2 | 1.250(31.7) | NPN & PNP N.O. | 20Hz | M12 Micro | 3 |
| NJ2-D-E02-2.062-V1 | 3000 | 2 | 2.062(52.4) | NPN & PNP N.O. | 20Hz | M12 Micro | 3 |
| NJ2-D-E02-2.875-V1 | 3000 | 2 | 2.875(73.0) | NPN & PNP N.O. | 20Hz | M12 Micro | 3 |
| NJ2-D-US-1.025-V12 | 3000 | 2 | 1.025 (26.0) | N.O. AC/DC | 20Hz | 1/2"-20 Micro AC | 3 |
| NJ2-D-US-1.250-V12 | 3000 | 2 | 1.250(31.7) | N.O. AC/DC | 20Hz | 1/2"-20 Micro AC | 3 |
| NJ2-D-US-2.062-V12 | 3000 | 2 | 2.062(52.4) | N.O. AC/DC | 20Hz | 1/2"-20 Micro AC | 3 |
| NJ2-D-US-1.025-V93 | 3000 | 2 | 1.025 (26.0) | N.O. AC/DC | 20Hz | 7/8"-16 Mini AC | 3 |
| NJ2-D-US-1.250-V93 | 3000 | 2 | 1.250(31.7) | N.O. AC/DC | 20Hz | 7/8"-16 Mini AC | 3 |
| NJ2-D-US-2.062-V93 | 3000 | 2 | 2.062(52.4) | N.O. AC/DC | 20Hz | 7/8"-16 Mini AC | 3 |
| NJ2-D-US-2.875-V93 | 3000 | 2 | 2.875(73.0) | N.O. AC/DC | 20Hz | 7/8"-16 Mini AC | 3 |

D-Series Models

| Model Number | Pressure Rating (psi) | Range (mm) | Probe Length [in. (mm)] | Electrical Output | Switching Frequency | Quick Disconnect | Dwg. No. |
|------------------------|-----------------------|------------|-------------------------|-------------------|---------------------|------------------|----------|
| NJ1.5-PD-E02-1.250-V95 | 3000 | 2 | 1.250(31.7) | NPN & PNP N.O. | 20Hz | 7/8"-16 Mini AC | 4 |
| NJ2-PD-E02-2.062-V95 | 3000 | 2 | 2.062(52.4) | NPN & PNP N.O. | 20Hz | 7/8"-16 Mini AC | 4 |
| NJ2-PD-E02-2.875-V95 | 3000 | 2 | 2.875(73.0) | NPN & PNP N.O. | 20Hz | 7/8"-16 Mini AC | 4 |
| NJ2-PD-E02-4.562-V95 | 3000 | 2 | 4.562(115.9) | NPN & PNP N.O. | 20Hz | 7/8"-16 Mini AC | 4 |
| NJ1.5-PD-US-1.250-V93 | 3000 | 2 | 1.250(31.7) | N.O. AC/DC | 20Hz | 7/8"-16 Mini AC | 4 |
| NJ2-PD-US-2.062-V93 | 3000 | 2 | 2.062(52.4) | N.O. AC/DC | 20Hz | 7/8"-16 Mini AC | 4 |
| NJ2-PD-US-2.875-V93 | 3000 | 2 | 2.875(73.0) | N.O. AC/DC | 20Hz | 7/8"-16 Mini AC | 4 |
| NJ2-PD-US-4.562-V93 | 3000 | 2 | 4.562(115.9) | N.O. AC/DC | 20Hz | 7/8"-16 Mini AC | 4 |

Weld Immune Cylinder Position Sensors

CONTINUED

Weld Immune Proximity Sensors

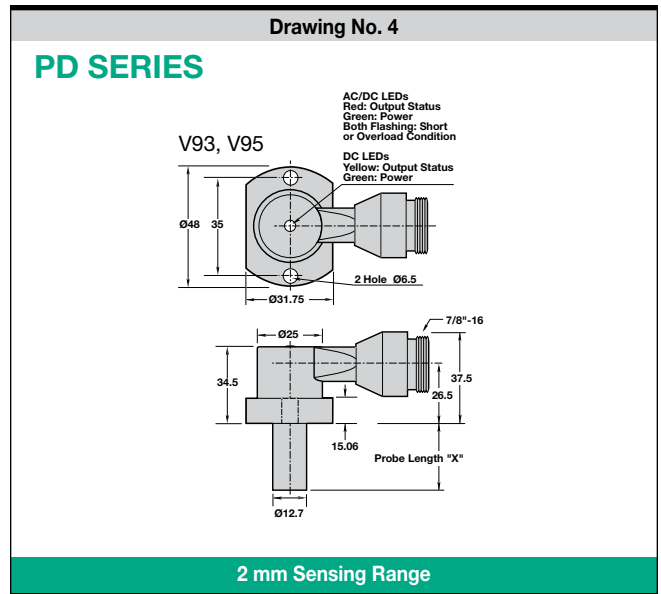
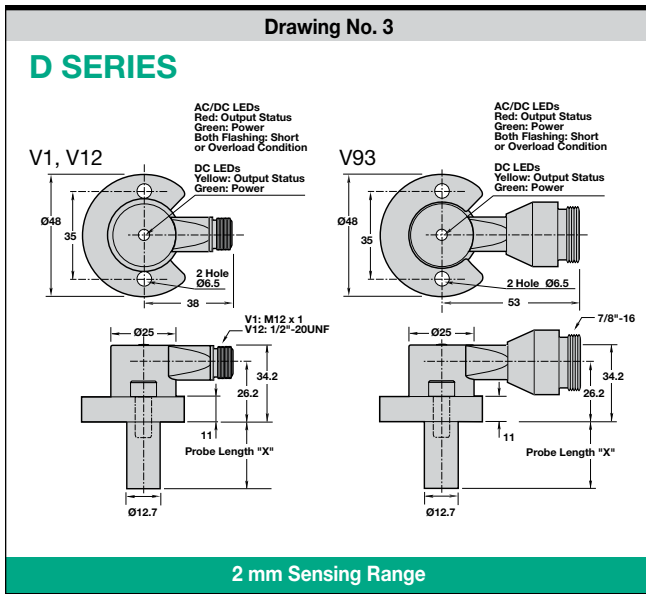
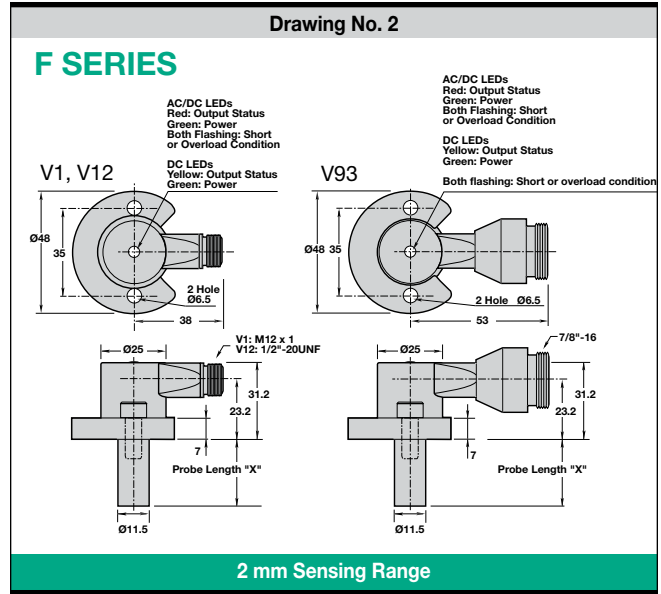
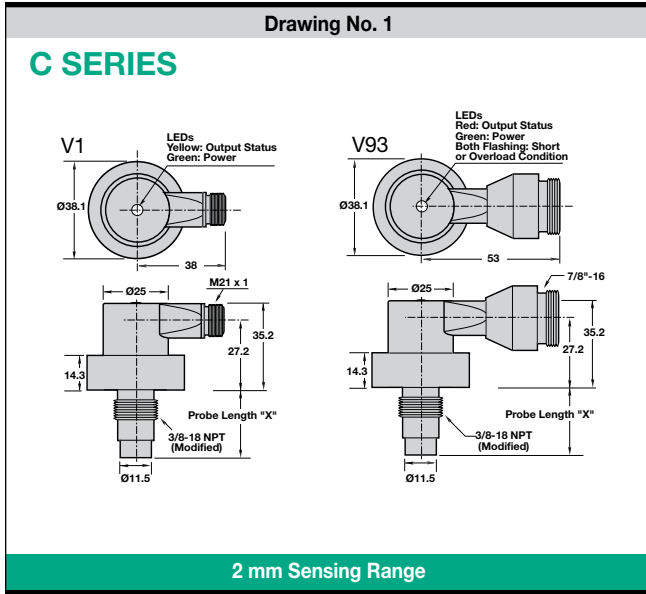

See pages
827-874 for
cordsets



See pages
885-892 for
accessories