

Please note that the data given here has been taken from the online catalog. For comprehensive information and data, please refer to the user documentation at <http://www.download.phoenixcontact.com>. The General Terms and Conditions of Use apply to Internet downloads.

▶ Extract from the online catalog



Surge protection type 3, as device protection for termination devices, error indication and remote indicator contact. Design: 120 V AC

The illustration shows version PT 2-PE/S-230 AC-ST

| | |
|-----------------|-----------------|
| Order No. | 2856812 |
| Ord designation | PT 2-PE/S-120AC |
| EAN | 4017918952952 |
| Pack | 1 Pcs. |
| Customs tariff | 85363010 |

▶ Certificates

CUL

| | |
|-----------------------|-------|
| Nominal voltage U_N | 120 V |
| Nominal current I_N | 20 A |

UL

| | |
|-----------------------|-------|
| Nominal voltage U_N | 120 V |
| Nominal current I_N | 20 A |

▸ Drawings

Dimensioned drawing

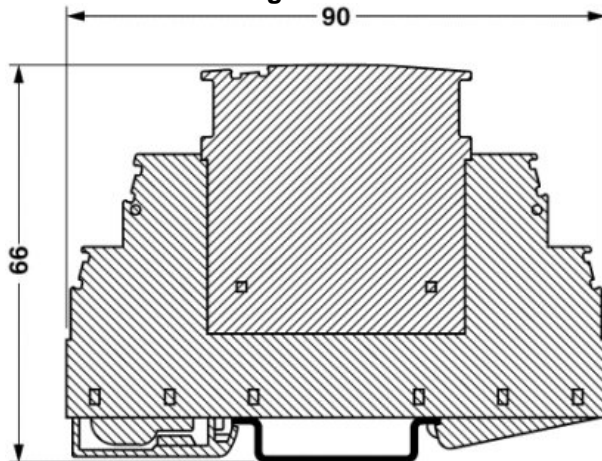

Circuit diagram

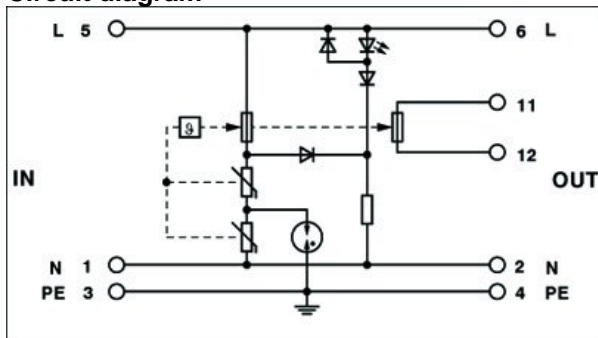

Approval logo



► Accessories

| Item | Designation | Description |
|----------------|-------------------------|-------------------------------------------------------------------------------------------------------------------------------------------------------------------------------------|
| Marking | | |
| 1050004 | ZB 5 :UNBEDRUCKT | Zack strip, unprinted, 10-section, for individual labeling with M-PEN, ZB-T or CMS system, pack is sufficient for 100 terminal blocks, for a terminal width of 5.2 mm, color: White |
| 2715212 | ZB 5,8,LGS:FORTL.ZAHLEN | Zack marker strip, 10-section, printed horizontally: with consecutive numbers, 1-10, 11-20 etc. up to 991-1000, color: white |
| 1050305 | ZB 5,8:SO/CMS | Zack strip, 10-section, divisible, special printing, marking according to customer requirements |
| 2715209 | ZB 5,8:UNBEDRUCKT | Zack strip, unprinted, strips with 10 labels for individual labeling with M-PEN or CMS system, for terminal block width: 5.8 mm, color: White |
| 1050017 | ZB 5,LGS:FORTL.ZAHLEN | Zack strip, 10-section, printed horizontally: with the numbers, 1-10, 11-20 etc. up to 991-1000, color: white |
| 1050415 | ZB 5,LGS:L1-N,PE | Zack strip, printed horizontally, strips with 10 labels, L1, L2, L3, N, PE, L1, L2, L3, N, PE, color: white |
| 1050295 | ZB 5:SO/CMS | Zack strip, 10-section, divisible, special printing, marking according to customer requirements |

► Additional products

| Item | Designation | Description |
|-----------------|-------------|----------------------------------------------|
| Assembly | | |
| 2839295 | SSA 3-6 | Shield fast connection for diameter 3-6 mm |
| 2839512 | SSA 5-10 | Shield fast connection for diameter 5 -10 mm |

► Address

PHOENIX CONTACT GmbH & Co. KG
Flachsmarktstr. 8
32825 Blomberg
Germany
Phone +49 5235 3 00
Fax +49 5235 3 41200
<http://www.phoenixcontact.com>
Phoenix Contact
Technical modifications reserved;