

Revision			
Rev.	Description	Date	Approved

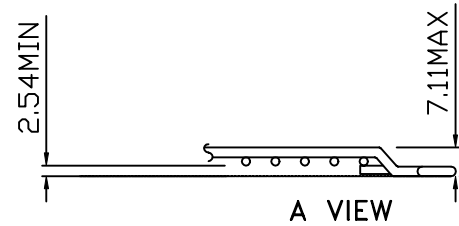
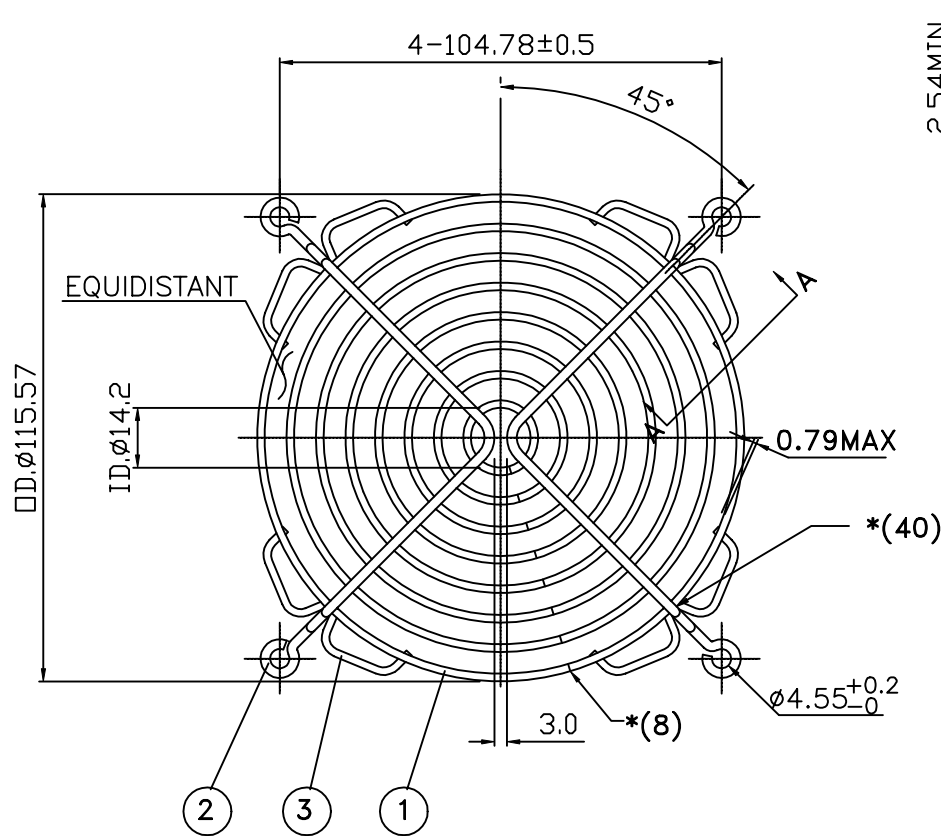

NOTES:

- 1.MATERIAL:SAE 1008(OR EQUIVALENT)
BRIGHT .BASIC .WIRE.
- 2.FINISH:BRIGHT NICKEL-CHROME PLATING.
- 3.0.35±0.05 DEPTH OF SERRATIONS ON WIRE.
- 4.WELD JOINTS TO WITHSTAND 70 LBS PULL FORCE.
- 5.RINGØ1.8;RIBØ2.3;WINGØ1.8.
- 6.GENERAL TOLERANCE UNLESS NOTED IS ±015*** & ±030**

Dim range (mm)	Tolerance +/- (mm)	Qualtek Electronics Corp. FAN-S DIVISION		
		Part Number: 08128	RoHS Compliant	
		Description: FAN GUARD		
		UNIT: mm	Rev A	
		Drawn/Date	Checked/Date	Approved/Date
		B.ZHANG 12-07-04	PC/12-07-04	JJH/12-07-04
<=6	0.24			
6-18	0.35			
18-50	0.50			
50-120	0.70			
120-250	0.93			
250-400	1.15			
400-630	1.40			
>630	1.50			