

16

R8C/24 Group, **R8C/25** Group
Hardware ManualRENESAS 16-BIT SINGLE-CHIP MCU
M16C FAMILY / R8C/Tiny SERIES

All information contained in these materials, including products and product specifications, represents information on the product at the time of publication and is subject to change by Renesas Technology Corp. without notice. Please review the latest information published by Renesas Technology Corp. through various means, including the Renesas Technology Corp. website (<http://www.renesas.com>).

Rev.2.00
Revision Date: Nov 01, 2006Renesas Technology
www.renesas.com

Notes regarding these materials

1. This document is provided for reference purposes only so that Renesas customers may select the appropriate Renesas products for their use. Renesas neither makes warranties or representations with respect to the accuracy or completeness of the information contained in this document nor grants any license to any intellectual property rights or any other rights of Renesas or any third party with respect to the information in this document.
2. Renesas shall have no liability for damages or infringement of any intellectual property or other rights arising out of the use of any information in this document, including, but not limited to, product data, diagrams, charts, programs, algorithms, and application circuit examples.
3. You should not use the products or the technology described in this document for the purpose of military applications such as the development of weapons of mass destruction or for the purpose of any other military use. When exporting the products or technology described herein, you should follow the applicable export control laws and regulations, and procedures required by such laws and regulations.
4. All information included in this document such as product data, diagrams, charts, programs, algorithms, and application circuit examples, is current as of the date this document is issued. Such information, however, is subject to change without any prior notice. Before purchasing or using any Renesas products listed in this document, please confirm the latest product information with a Renesas sales office. Also, please pay regular and careful attention to additional and different information to be disclosed by Renesas such as that disclosed through our website. (<http://www.renesas.com>)
5. Renesas has used reasonable care in compiling the information included in this document, but Renesas assumes no liability whatsoever for any damages incurred as a result of errors or omissions in the information included in this document.
6. When using or otherwise relying on the information in this document, you should evaluate the information in light of the total system before deciding about the applicability of such information to the intended application. Renesas makes no representations, warranties or guaranties regarding the suitability of its products for any particular application and specifically disclaims any liability arising out of the application and use of the information in this document or Renesas products.
7. With the exception of products specified by Renesas as suitable for automobile applications, Renesas products are not designed, manufactured or tested for applications or otherwise in systems the failure or malfunction of which may cause a direct threat to human life or create a risk of human injury or which require especially high quality and reliability such as safety systems, or equipment or systems for transportation and traffic, healthcare, combustion control, aerospace and aeronautics, nuclear power, or undersea communication transmission. If you are considering the use of our products for such purposes, please contact a Renesas sales office beforehand. Renesas shall have no liability for damages arising out of the uses set forth above.
8. Notwithstanding the preceding paragraph, you should not use Renesas products for the purposes listed below:
 - (1) artificial life support devices or systems
 - (2) surgical implantations
 - (3) healthcare intervention (e.g., excision, administration of medication, etc.)
 - (4) any other purposes that pose a direct threat to human lifeRenesas shall have no liability for damages arising out of the uses set forth in the above and purchasers who elect to use Renesas products in any of the foregoing applications shall indemnify and hold harmless Renesas Technology Corp., its affiliated companies and their officers, directors, and employees against any and all damages arising out of such applications.
9. You should use the products described herein within the range specified by Renesas, especially with respect to the maximum rating, operating supply voltage range, movement power voltage range, heat radiation characteristics, installation and other product characteristics. Renesas shall have no liability for malfunctions or damages arising out of the use of Renesas products beyond such specified ranges.
10. Although Renesas endeavors to improve the quality and reliability of its products, IC products have specific characteristics such as the occurrence of failure at a certain rate and malfunctions under certain use conditions. Please be sure to implement safety measures to guard against the possibility of physical injury, and injury or damage caused by fire in the event of the failure of a Renesas product, such as safety design for hardware and software including but not limited to redundancy, fire control and malfunction prevention, appropriate treatment for aging degradation or any other applicable measures. Among others, since the evaluation of microcomputer software alone is very difficult, please evaluate the safety of the final products or system manufactured by you.
11. In case Renesas products listed in this document are detached from the products to which the Renesas products are attached or affixed, the risk of accident such as swallowing by infants and small children is very high. You should implement safety measures so that Renesas products may not be easily detached from your products. Renesas shall have no liability for damages arising out of such detachment.
12. This document may not be reproduced or duplicated, in any form, in whole or in part, without prior written approval from Renesas.
13. Please contact a Renesas sales office if you have any questions regarding the information contained in this document, Renesas semiconductor products, or if you have any other inquiries.

General Precautions in the Handling of MPU/MCU Products

The following usage notes are applicable to all MPU/MCU products from Renesas. For detailed usage notes on the products covered by this manual, refer to the relevant sections of the manual. If the descriptions under General Precautions in the Handling of MPU/MCU Products and in the body of the manual differ from each other, the description in the body of the manual takes precedence.

1. Handling of Unused Pins

Handle unused pins in accord with the directions given under Handling of Unused Pins in the manual.

- The input pins of CMOS products are generally in the high-impedance state. In operation with an unused pin in the open-circuit state, extra electromagnetic noise is induced in the vicinity of LSI, an associated shoot-through current flows internally, and malfunctions occur due to the false recognition of the pin state as an input signal become possible. Unused pins should be handled as described under Handling of Unused Pins in the manual.

2. Processing at Power-on

The state of the product is undefined at the moment when power is supplied.

- The states of internal circuits in the LSI are indeterminate and the states of register settings and pins are undefined at the moment when power is supplied.

In a finished product where the reset signal is applied to the external reset pin, the states of pins are not guaranteed from the moment when power is supplied until the reset process is completed.

In a similar way, the states of pins in a product that is reset by an on-chip power-on reset function are not guaranteed from the moment when power is supplied until the power reaches the level at which resetting has been specified.

3. Prohibition of Access to Reserved Addresses

Access to reserved addresses is prohibited.

- The reserved addresses are provided for the possible future expansion of functions. Do not access these addresses; the correct operation of LSI is not guaranteed if they are accessed.

4. Clock Signals

After applying a reset, only release the reset line after the operating clock signal has become stable.

When switching the clock signal during program execution, wait until the target clock signal has stabilized.

- When the clock signal is generated with an external resonator (or from an external oscillator) during a reset, ensure that the reset line is only released after full stabilization of the clock signal. Moreover, when switching to a clock signal produced with an external resonator (or by an external oscillator) while program execution is in progress, wait until the target clock signal is stable.

5. Differences between Products

Before changing from one product to another, i.e. to one with a different type number, confirm that the change will not lead to problems.

- The characteristics of MPU/MCU in the same group but having different type numbers may differ because of the differences in internal memory capacity and layout pattern. When changing to products of different type numbers, implement a system-evaluation test for each of the products.

How to Use This Manual

1. Purpose and Target Readers

This manual is designed to provide the user with an understanding of the hardware functions and electrical characteristics of the MCU. It is intended for users designing application systems incorporating the MCU. A basic knowledge of electric circuits, logical circuits, and MCUs is necessary in order to use this manual.

The manual comprises an overview of the product; descriptions of the CPU, system control functions, peripheral functions, and electrical characteristics; and usage notes.

Particular attention should be paid to the precautionary notes when using the manual. These notes occur within the body of the text, at the end of each section, and in the Usage Notes section.

The revision history summarizes the locations of revisions and additions. It does not list all revisions. Refer to the text of the manual for details.

The following documents apply to the R8C/24 Group, R8C/25 Group. Make sure to refer to the latest versions of these documents. The newest versions of the documents listed may be obtained from the Renesas Technology Web site.

Document Type	Description	Document Title	Document No.
Datasheet	Hardware overview and electrical characteristics	R8C/24 Group, R8C/25 Group Datasheet	REJ03B0117
Hardware manual	Hardware specifications (pin assignments, memory maps, peripheral function specifications, electrical characteristics, timing charts) and operation description Note: Refer to the application notes for details on using peripheral functions.	R8C/24 Group, R8C/25 Group Hardware Manual	This hardware manual
Software manual	Description of CPU instruction set	R8C/Tiny Series Software Manual	REJ09B0001
Application note	Information on using peripheral functions and application examples Sample programs Information on writing programs in assembly language and C	Available from Renesas Technology Web site.	
Renesas technical update	Product specifications, updates on documents, etc.		

2. Notation of Numbers and Symbols

The notation conventions for register names, bit names, numbers, and symbols used in this manual are described below.

(1) Register Names, Bit Names, and Pin Names

Registers, bits, and pins are referred to in the text by symbols. The symbol is accompanied by the word “register,” “bit,” or “pin” to distinguish the three categories.

Examples the PM03 bit in the PM0 register
P3_5 pin, VCC pin

(2) Notation of Numbers

The indication “b” is appended to numeric values given in binary format. However, nothing is appended to the values of single bits. The indication “h” is appended to numeric values given in hexadecimal format. Nothing is appended to numeric values given in decimal format.

Examples Binary: 11b
Hexadecimal: EFA0h
Decimal: 1234

3. Register Notation

The symbols and terms used in register diagrams are described below.

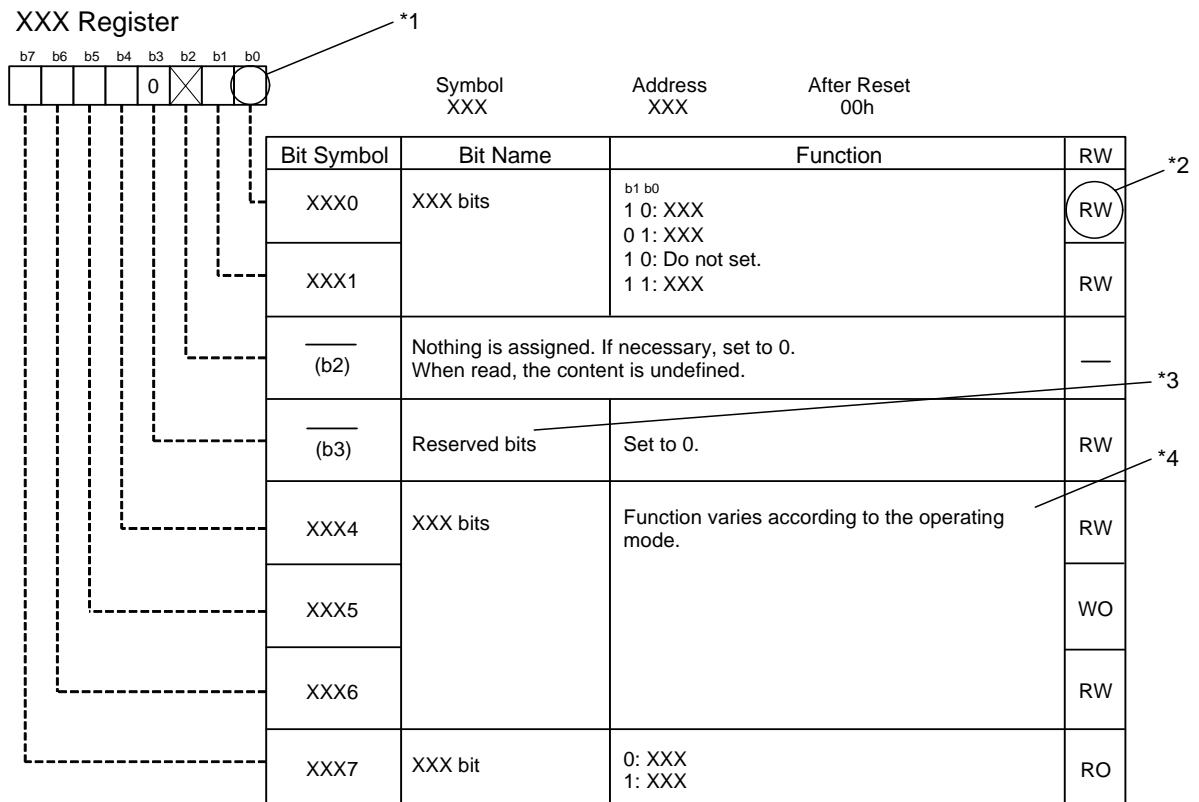

*1
Blank: Set to 0 or 1 according to the application.
0: Set to 0.
1: Set to 1.
X: Nothing is assigned.

*2
RW: Read and write.
RO: Read only.
WO: Write only.
—: Nothing is assigned.

*3
• Reserved bit
Reserved bit. Set to specified value.

*4
• Nothing is assigned
Nothing is assigned to the bit. As the bit may be used for future functions, if necessary, set to 0.
• Do not set to a value
Operation is not guaranteed when a value is set.
• Function varies according to the operating mode.
The function of the bit varies with the peripheral function mode. Refer to the register diagram for information on the individual modes.

4. List of Abbreviations and Acronyms

Abbreviation	Full Form
ACIA	Asynchronous Communication Interface Adapter
bps	bits per second
CRC	Cyclic Redundancy Check
DMA	Direct Memory Access
DMAC	Direct Memory Access Controller
GSM	Global System for Mobile Communications
Hi-Z	High Impedance
IEBus	Inter Equipment bus
I/O	Input/Output
IrDA	Infrared Data Association
LSB	Least Significant Bit
MSB	Most Significant Bit
NC	Non-Connection
PLL	Phase Locked Loop
PWM	Pulse Width Modulation
SFR	Special Function Registers
SIM	Subscriber Identity Module
UART	Universal Asynchronous Receiver/Transmitter
VCO	Voltage Controlled Oscillator

Table of Contents

SFR Page Reference	B - 1
1. Overview	1
1.1 Applications	1
1.2 Performance Overview	2
1.3 Block Diagram	4
1.4 Product Information	5
1.5 Pin Assignments	9
1.6 Pin Functions	11
2. Central Processing Unit (CPU)	13
2.1 Data Registers (R0, R1, R2, and R3)	14
2.2 Address Registers (A0 and A1)	14
2.3 Frame Base Register (FB)	14
2.4 Interrupt Table Register (INTB)	14
2.5 Program Counter (PC)	14
2.6 User Stack Pointer (USP) and Interrupt Stack Pointer (ISP)	14
2.7 Static Base Register (SB)	14
2.8 Flag Register (FLG)	14
2.8.1 Carry Flag (C)	14
2.8.2 Debug Flag (D)	14
2.8.3 Zero Flag (Z)	14
2.8.4 Sign Flag (S)	14
2.8.5 Register Bank Select Flag (B)	14
2.8.6 Overflow Flag (O)	14
2.8.7 Interrupt Enable Flag (I)	15
2.8.8 Stack Pointer Select Flag (U)	15
2.8.9 Processor Interrupt Priority Level (IPL)	15
2.8.10 Reserved Bit	15
3. Memory	16
3.1 R8C/24 Group	16
3.2 R8C/25 Group	17
4. Special Function Registers (SFRs)	18
5. Resets	25
5.1 Hardware Reset	28
5.1.1 When Power Supply is Stable	28
5.1.2 Power On	28
5.2 Power-On Reset Function	30
5.3 Voltage Monitor 0 Reset	31
5.4 Voltage Monitor 1 Reset	31
5.5 Voltage Monitor 2 Reset	31
5.6 Watchdog Timer Reset	32
5.7 Software Reset	32
6. Voltage Detection Circuit	33
6.1 VCC Input Voltage	40

6.1.1	Monitoring Vdet0	40
6.1.2	Monitoring Vdet1	40
6.1.3	Monitoring Vdet2	40
6.2	Voltage Monitor 0 Reset	41
6.3	Voltage Monitor 1 Interrupt and Voltage Monitor 1 Reset	42
6.4	Voltage Monitor 2 Interrupt and Voltage Monitor 2 Reset	44
7.	Programmable I/O Ports	46
7.1	Functions of Programmable I/O Ports	46
7.2	Effect on Peripheral Functions	47
7.3	Pins Other than Programmable I/O Ports	47
7.4	Port settings	59
7.5	Unassigned Pin Handling	70
8.	Processor Mode	71
8.1	Processor Modes	71
9.	Bus	72
10.	Clock Generation Circuit	73
10.1	XIN Clock	81
10.2	On-Chip Oscillator Clocks	82
10.2.1	Low-Speed On-Chip Oscillator Clock	82
10.2.2	High-Speed On-Chip Oscillator Clock	82
10.3	XCIN Clock	83
10.4	CPU Clock and Peripheral Function Clock	84
10.4.1	System Clock	84
10.4.2	CPU Clock	84
10.4.3	Peripheral Function Clock (f1, f2, f4, f8, and f32)	84
10.4.4	fOCO	84
10.4.5	fOCO40M	84
10.4.6	fOCO-F	84
10.4.7	fOCO-S	84
10.4.8	fOCO128	84
10.4.9	fC4 and fC32	85
10.5	Power Control	86
10.5.1	Standard Operating Mode	86
10.5.2	Wait Mode	88
10.5.3	Stop Mode	92
10.6	Oscillation Stop Detection Function	95
10.6.1	How to Use Oscillation Stop Detection Function	95
10.7	Notes on Clock Generation Circuit	98
10.7.1	Stop Mode	98
10.7.2	Wait Mode	98
10.7.3	Oscillation Stop Detection Function	98
10.7.4	Oscillation Circuit Constants	98

11.	Protection	99
12.	Interrupts	100
12.1	Interrupt Overview	100
12.1.1	Types of Interrupts	100
12.1.2	Software Interrupts	101
12.1.3	Special Interrupts	102
12.1.4	Peripheral Function Interrupt	102
12.1.5	Interrupts and Interrupt Vectors	103
12.1.6	Interrupt Control	105
12.2	$\overline{\text{INT}}$ Interrupt	114
12.2.1	$\overline{\text{INT}}_i$ Interrupt (i = 0 to 3)	114
12.2.2	$\overline{\text{INT}}_i$ Input Filter (i = 0 to 3)	116
12.3	Key Input Interrupt	117
12.4	Address Match Interrupt	119
12.5	Timer RD Interrupt, Clock Synchronous Serial I/O with Chip Select Interrupts, and I ² C bus Interface Interrupt (Interrupts with Multiple Interrupt Request Sources)	121
12.6	Notes on Interrupts	123
12.6.1	Reading Address 00000h	123
12.6.2	SP Setting	123
12.6.3	External Interrupt and Key Input Interrupt	123
12.6.4	Watchdog Timer Interrupt	123
12.6.5	Changing Interrupt Sources	124
12.6.6	Changing Interrupt Control Register Contents	125
13.	Watchdog Timer	126
13.1	Count Source Protection Mode Disabled	129
13.2	Count Source Protection Mode Enabled	130
14.	Timers	131
14.1	Timer RA	133
14.1.1	Timer Mode	136
14.1.2	Pulse Output Mode	138
14.1.3	Event Counter Mode	140
14.1.4	Pulse Width Measurement Mode	142
14.1.5	Pulse Period Measurement Mode	145
14.1.6	Notes on Timer RA	148
14.2	Timer RB	149
14.2.1	Timer Mode	153
14.2.2	Programmable Waveform Generation Mode	156
14.2.3	Programmable One-shot Generation Mode	158
14.2.4	Programmable Wait One-Shot Generation Mode	162
14.2.5	Notes on Timer RB	166
14.3	Timer RD	167
14.3.1	Count Sources	172
14.3.2	Buffer Operation	173
14.3.3	Synchronous Operation	175
14.3.4	Pulse Output Forced Cutoff	176
14.3.5	Input Capture Function	178

14.3.6	Output Compare Function	192
14.3.7	PWM Mode	209
14.3.8	Reset Synchronous PWM Mode	222
14.3.9	Complementary PWM Mode	232
14.3.10	PWM3 Mode	246
14.3.11	Timer RD Interrupt	259
14.3.12	Notes on Timer RD	261
14.4	Timer RE	267
14.4.1	Real-Time Clock Mode	268
14.4.2	Output Compare Mode	276
14.4.3	Notes on Timer RE	282
15.	Serial Interface	285
15.1	Clock Synchronous Serial I/O Mode	291
15.1.1	Polarity Select Function	294
15.1.2	LSB First/MSB First Select Function	294
15.1.3	Continuous Receive Mode	295
15.2	Clock Asynchronous Serial I/O (UART) Mode	296
15.2.1	Bit Rate	300
15.3	Notes on Serial Interface	301
16.	Clock Synchronous Serial Interface	302
16.1	Mode Selection	302
16.2	Clock Synchronous Serial I/O with Chip Select (SSU)	303
16.2.1	Transfer Clock	312
16.2.2	SS Shift Register (SSTRSR)	314
16.2.3	Interrupt Requests	315
16.2.4	Communication Modes and Pin Functions	316
16.2.5	Clock Synchronous Communication Mode	317
16.2.6	Operation in 4-Wire Bus Communication Mode	324
16.2.7	SCS Pin Control and Arbitration	330
16.2.8	Notes on Clock Synchronous Serial I/O with Chip Select	331
16.3	I ² C bus Interface	332
16.3.1	Transfer Clock	342
16.3.2	Interrupt Requests	343
16.3.3	I ² C bus Interface Mode	344
16.3.4	Clock Synchronous Serial Mode	355
16.3.5	Noise Canceller	358
16.3.6	Bit Synchronization Circuit	359
16.3.7	Examples of Register Setting	360
16.3.8	Notes on I ² C bus Interface	364
17.	Hardware LIN	365
17.1	Features	365
17.2	Input/Output Pins	366
17.3	Register Configuration	367
17.4	Functional Description	369
17.4.1	Master Mode	369
17.4.2	Slave Mode	372

17.4.3	Bus Collision Detection Function	376
17.4.4	Hardware LIN End Processing	377
17.5	Interrupt Requests	378
17.6	Notes on Hardware LIN	379
18.	A/D Converter	380
18.1	One-Shot Mode	384
18.2	Repeat Mode	387
18.3	Sample and Hold	390
18.4	A/D Conversion Cycles	390
18.5	Internal Equivalent Circuit of Analog Input	391
18.6	Output Impedance of Sensor under A/D Conversion	392
18.7	Notes on A/D Converter	393
19.	Flash Memory	394
19.1	Overview	394
19.2	Memory Map	395
19.3	Functions to Prevent Rewriting of Flash Memory	397
19.3.1	ID Code Check Function	397
19.3.2	ROM Code Protect Function	398
19.4	CPU Rewrite Mode	399
19.4.1	EW0 Mode	400
19.4.2	EW1 Mode	400
19.4.3	Software Commands	409
19.4.4	Status Registers	414
19.4.5	Full Status Check	415
19.5	Standard Serial I/O Mode	417
19.5.1	ID Code Check Function	417
19.6	Parallel I/O Mode	421
19.6.1	ROM Code Protect Function	421
19.7	Notes on Flash Memory	422
19.7.1	CPU Rewrite Mode	422
20.	Electrical Characteristics	425
21.	Usage Notes	451
21.1	Notes on Clock Generation Circuit	451
21.1.1	Stop Mode	451
21.1.2	Wait Mode	451
21.1.3	Oscillation Stop Detection Function	451
21.1.4	Oscillation Circuit Constants	451
21.2	Notes on Interrupts	452
21.2.1	Reading Address 00000h	452
21.2.2	SP Setting	452
21.2.3	External Interrupt and Key Input Interrupt	452
21.2.4	Watchdog Timer Interrupt	452
21.2.5	Changing Interrupt Sources	453
21.2.6	Changing Interrupt Control Register Contents	454

21.3	Notes on Timers	455
21.3.1	Notes on Timer RA	455
21.3.2	Notes on Timer RB	456
21.3.3	Notes on Timer RD	457
21.3.4	Notes on Timer RE	463
21.4	Notes on Serial Interface	466
21.5	Notes on Clock Synchronous Serial Interface	467
21.5.1	Notes on Clock Synchronous Serial I/O with Chip Select	467
21.5.2	Notes on I ² C bus Interface	467
21.6	Notes on Hardware LIN	468
21.7	Notes on A/D Converter	469
21.8	Notes on Flash Memory	470
21.8.1	CPU Rewrite Mode	470
21.9	Notes on Noise	473
21.9.1	Inserting a Bypass Capacitor between VCC and VSS Pins as a Countermeasure against Noise and Latch-up	473
21.9.2	Countermeasures against Noise Error of Port Control Registers	473
22.	Notes on On-Chip Debugger	474
Appendix 1.	Package Dimensions	475
Appendix 2.	Connection Examples between Serial Writer and On-Chip Debugging Emulator	476
Appendix 3.	Example of Oscillation Evaluation Circuit	477
Index	478

SFR Page Reference

Address	Register	Symbol	Page
0000h			
0001h			
0002h			
0003h			
0004h	Processor Mode Register 0	PM0	71
0005h	Processor Mode Register 1	PM1	71
0006h	System Clock Control Register 0	CM0	75
0007h	System Clock Control Register 1	CM1	76
0008h			
0009h			
000Ah	Protect Register	PRCR	99
000Bh			
000Ch	Oscillation Stop Detection Register	OCD	77
000Dh	Watchdog Timer Reset Register	WDTR	128
000Eh	Watchdog Timer Start Register	WDTS	128
000Fh	Watchdog Timer Control Register	WDC	127
0010h	Address Match Interrupt Register 0	RMAD0	120
0011h			
0012h			
0013h	Address Match Interrupt Enable Register	AIER	120
0014h	Address Match Interrupt Register 1	RMAD1	120
0015h			
0016h			
0017h			
0018h			
0019h			
001Ah			
001Bh			
001Ch	Count Source Protection Mode Register	CSPR	128
001Dh			
001Eh			
001Fh			
0020h			
0021h			
0022h			
0023h	High-Speed On-Chip Oscillator Control Register 0	FRA0	78
0024h	High-Speed On-Chip Oscillator Control Register 1	FRA1	78
0025h	High-Speed On-Chip Oscillator Control Register 2	FRA2	79
0026h			
0027h			
0028h	Clock Prescaler Reset Flag	CPSRF	80
0029h	High-Speed On-Chip Oscillator Control Register 4	FRA4	79
002Ah			
002Bh	High-Speed On-Chip Oscillator Control Register 6	FRA6	79

0030h			
0031h	Voltage Detection Register 1	VCA1	36
0032h	Voltage Detection Register 2	VCA2	36, 80
0033h			
0034h			
0035h			
0036h	Voltage Monitor 1 Circuit Control Register	VW1C	38
0037h	Voltage Monitor 2 Circuit Control Register	VW2C	39
0038h	Voltage Monitor 0 Circuit Control Register	VW0C	37
0039h			
003Ah			
003Bh			
003Ch			
003Dh			
003Eh			
003Fh			

Address	Register	Symbol	Page
0040h			
0041h			
0042h			
0043h			
0044h			
0045h			
0046h			
0047h			
0048h	Timer RD0 Interrupt Control Register	TRD0IC	106
0049h	Timer RD1 Interrupt Control Register	TRD1IC	106
004Ah	Timer RE Interrupt Control Register	TREIC	105
004Bh			
004Ch			
004Dh	Key Input Interrupt Control Register	KUPIC	105
004Eh	A/D Conversion Interrupt Control Register	ADIC	105
004Fh	SSU/IIC Interrupt Control Register	SSUIC/IICIC	106
0050h			
0051h	UART0 Transmit Interrupt Control Register	S0TIC	105
0052h	UART0 Receive Interrupt Control Register	S0RIC	105
0053h	UART1 Transmit Interrupt Control Register	S1TIC	105
0054h	UART1 Receive Interrupt Control Register	S1RIC	105
0055h	INT2 Interrupt Control Register	INT2IC	107
0056h	Timer RA Interrupt Control Register	TRAIC	105
0057h			
0058h	Timer RB Interrupt Control Register	TRBIC	105
0059h	INT1 Interrupt Control Register	INT1IC	107
005Ah	INT3 Interrupt Control Register	INT3IC	107
005Bh			
005Ch			
005Dh	INT0 Interrupt Control Register	INT0IC	107
005Eh			
005Fh			
0060h			
0061h			
0062h			
0063h			
0064h			
0065h			
0066h			
0067h			
0068h			
0069h			
006Ah			
006Bh			
006Ch			
006Dh			
006Eh			
006Fh			
0070h			
0071h			
0072h			
0073h			
0074h			
0075h			
0076h			
0077h			
0078h			
0079h			
007Ah			
007Bh			
007Ch			
007Dh			
007Eh			
007Fh			

NOTE:

1. The blank regions are reserved. Do not access locations in these regions.

Address	Register	Symbol	Page
0080h			
0081h			
0082h			
0083h			
0084h			
0085h			
0086h			
0087h			
0088h			
0089h			
008Ah			
008Bh			
008Ch			
008Dh			
008Eh			
008Fh			
0090h			
0091h			
0092h			
0093h			
0094h			
0095h			
0096h			
0097h			
0098h			
0099h			
009Ah			
009Bh			
009Ch			
009Dh			
009Eh			
009Fh			
00A0h	UART0 Transmit/Receive Mode Register	U0MR	288
00A1h	UART0 Bit Rate Register	U0BRG	288
00A2h	UART0 Transmit Buffer Register	U0TB	287
00A3h			
00A4h	UART0 Transmit/Receive Control Register 0	U0C0	289
00A5h	UART0 Transmit/Receive Control Register 1	U0C1	290
00A6h	UART0 Receive Buffer Register	U0RB	287
00A7h			
00A8h	UART1 Transmit/Receive Mode Register	U1MR	288
00A9h	UART1 Bit Rate Register	U1BRG	288
00AAh	UART1 Transmit Buffer Register	U1TB	287
00ABh			
00ACh	UART1 Transmit/Receive Control Register 0	U1C0	289
00ADh	UART1 Transmit/Receive Control Register 1	U1C1	290
00AEh	UART1 Receive Buffer Register	U1RB	287
00AFh			
00B0h			
00B1h			
00B2h			
00B3h			
00B4h			
00B5h			
00B6h			
00B7h			
00B8h	SS Control Register H / IIC bus Control Register 1	SSCRH/ICCR1	305, 335
00B9h	SS Control Register L / IIC bus Control Register 2	SSCRL/ICCR2	306, 336
00BAh	SS Mode Register / IIC bus Mode Register	SSMR/ICMR	307, 337
00BBh	SS Enable Register / IIC bus Interrupt Enable Register	SSER/ICIER	308, 338
00BCh	SS Status Register / IIC bus Status Register	SSSR/ICSR	309, 339
00BDh	SS Mode Register 2 / Slave Address Register	SSMR2/SAR	310, 340
00BEh	SS Transmit Data Register/IIC Bus Transmit Data Register	SSTDR/ICDRT	311, 340
00BFh	SS Receive Data Register/IIC Bus Receive Data Register	SSRDR/ICDRR	311, 341

Address	Register	Symbol	Page
00C0h	A/D Register	AD	383
00C1h			
00C2h			
00C3h			
00C4h			
00C5h			
00C6h			
00C7h			
00C8h			
00C9h			
00CAh			
00CBh			
00CCh			
00CDh			
00CEh			
00CFh			
00D0h			
00D1h			
00D2h			
00D3h			
00D4h	A/D Control Register 2	ADCON2	383
00D5h			
00D6h	A/D Control Register 0	ADCON0	382
00D7h	A/D Control Register 1	ADCON1	383
00D8h			
00D9h			
00DAh			
00DBh			
00DCh			
00DDh			
00DEh			
00DFh			
00E0h	Port P0 Register	P0	56
00E1h	Port P1 Register	P1	56
00E2h	Port P0 Direction Register	PD0	56
00E3h	Port P1 Direction Register	PD1	56
00E4h	Port P2 Register	P2	56
00E5h	Port P3 Register	P3	56
00E6h	Port P2 Direction Register	PD2	56
00E7h	Port P3 Direction Register	PD3	56
00E8h	Port P4 Register	P4	56
00E9h			
00EAh	Port P4 Direction Register	PD4	56
00EBh			
00ECh	Port P6 Register	P6	56
00EDh			
00EEh	Port P6 Direction Register	PD6	56
00EFh			
00F0h			
00F1h			
00F2h			
00F3h			
00F4h	Port P2 Drive Capacity Control Register	P2DRR	58
00F5h	UART1 Function Select Register	U1SR	290
00F6h			
00F7h			
00F8h	Port Mode Register	PMR	58, 290, 311, 341
00F9h	External Input Enable Register	INTEN	114
00FAh	INT Input Filter Select Register	INTF	115
00FBh	Key Input Enable Register	KIEN	118
00FCh	Pull-Up Control Register 0	PUR0	57
00FDh	Pull-Up Control Register 1	PUR1	57
00FEh			
00FFh			

NOTE:

1. The blank regions are reserved. Do not access locations in these regions.

Address	Register	Symbol	Page
0100h	Timer RA Control Register	TRACR	134
0101h	Timer RA I/O Control Register	TRAIOC	134, 136, 139, 141, 143, 146
0102h	Timer RA Mode Register	TRAMR	135
0103h	Timer RA Prescaler Register	TRAPRE	135
0104h	Timer RA Register	TRA	135
0105h			
0106h	LIN Control Register	LINCR	367
0107h	LIN Status Register	LINST	368
0108h	Timer RB Control Register	TRBCR	150
0109h	Timer RB One-Shot Control Register	TRBOCR	150
010Ah	Timer RB I/O Control Register	TRBIOC	151, 153, 157, 159, 164
010Bh	Timer RB Mode Register	TRBMR	151
010Ch	Timer RB Prescaler Register	TRBPRE	152
010Dh	Timer RB Secondary Register	TRBSC	152
010Eh	Timer RB Primary Register	TRBPR	152
010Fh			
0110h			
0111h			
0112h			
0113h			
0114h			
0115h			
0116h			
0117h			
0118h	Timer RE Second Data Register / Counter Data Register	TRESEC	270, 278
0119h	Timer RE Minute Data Register / Compare Data Register	TREMIN	270, 278
011Ah	Timer RE Hour Data Register	TREHR	271
011Bh	Timer RE Day of Week Data Register	TREWK	271
011Ch	Timer RE Control Register 1	TRECR1	272, 279
011Dh	Timer RE Control Register 2	TRECR2	273, 279
011Eh	Timer RE Clock Source Select Register	TRECSR	274, 280
011Fh			
0120h			
0121h			
0122h			
0123h			
0124h			
0125h			
0126h			
0127h			
0128h			
0129h			
012Ah			
012Bh			
012Ch			
012Dh			
012Eh			
012Fh			

NOTE:

1. The blank regions are reserved. Do not access locations in these regions.

Address	Register	Symbol	Page
0130h			
0131h			
0132h			
0133h			
0134h			
0135h			
0136h			
0137h	Timer RD Start Register	TRDSTR	180, 194, 211, 224, 234, 248
0138h	Timer RD Mode Register	TRDMR	180, 194, 211, 224, 235, 249
0139h	Timer RD PWM Mode Register	TRDPMR	181, 195, 212
013Ah	Timer RD Function Control Register	TRDFCR	182, 196, 213, 225, 236, 250
013Bh	Timer RD Output Master Enable Register 1	TRDOER1	197, 214, 226, 237, 251
013Ch	Timer RD Output Master Enable Register 2	TRDOER2	197, 214, 226, 237, 251
013Dh	Timer RD Output Control Register	TRDOCR	198, 215, 252
013Eh	Timer RD Digital Filter Function Select Register 0	TRDDF0	183
013Fh	Timer RD Digital Filter Function Select Register 1	TRDDF1	183
0140h	Timer RD Control Register 0	TRDCR0	184, 199, 215, 227, 238, 253
0141h	Timer RD I/O Control Register A0	TRDIORA0	185, 200
0142h	Timer RD I/O Control Register C0	TRDIORC0	186, 201
0143h	Timer RD Status Register 0	TRDSR0	187, 202, 216, 228, 239, 254
0144h	Timer RD Interrupt Enable Register 0	TRDIER0	188, 203, 217, 229, 240, 255
0145h	Timer RD PWM Mode Output Level Control Register 0	TRDPOCR0	218
0146h	Timer RD Counter 0	TRD0	188, 204, 218, 229, 241, 255
0147h			
0148h	Timer RD General Register A0	TRDGRA0	189, 204, 219, 230, 241, 256
0149h			
014Ah	Timer RD General Register B0	TRDGRB0	189, 204, 219, 230, 241, 256
014Bh			
014Ch	Timer RD General Register C0	TRDGRC0	189, 204, 219, 230, 256
014Dh			
014Eh	Timer RD General Register D0	TRDGRD0	189, 204, 219, 230, 241, 256
014Fh			
0150h	Timer RD Control Register 1	TRDCR1	184, 199, 215, 238
0151h	Timer RD I/O Control Register A1	TRDIORA1	185, 200
0152h	Timer RD I/O Control Register C1	TRDIORC1	186, 201
0153h	Timer RD Status Register 1	TRDSR1	187, 202, 216, 228, 239, 254
0154h	Timer RD Interrupt Enable Register 1	TRDIER1	188, 203, 217, 229, 240, 255
0155h	Timer RD PWM Mode Output Level Control Register 1	TRDPOCR1	218
0156h	Timer RD Counter 1	TRD1	188, 204, 218, 241
0157h			
0158h	Timer RD General Register A1	TRDGRA1	189, 204, 219, 230, 241, 256
0159h			
015Ah	Timer RD General Register B1	TRDGRB1	189, 204, 219, 230, 241, 256
015Bh			
015Ch	Timer RD General Register C1	TRDGRC1	189, 204, 219, 230, 241, 256
015Dh			
015Eh	Timer RD General Register D1	TRDGRD1	189, 204, 219, 230, 241, 256
015Fh			

Address	Register	Symbol	Page
0160h			
0161h			
0162h			
0163h			
0164h			
0165h			
0166h			
0167h			
0168h			
0169h			
016Ah			
016Bh			
016Ch			
016Dh			
016Eh			
016Fh			
0170h			
0171h			
0172h			
0173h			
0174h			
0175h			
0176h			
0177h			
0178h			
0179h			
017Ah			
017Bh			
017Ch			
017Dh			
017Eh			
017Fh			
0180h			
0181h			
0182h			
0183h			
0184h			
0185h			
0186h			
0187h			
0188h			
0189h			
018Ah			
018Bh			
018Ch			
018Dh			
018Eh			
018Fh			
0190h			
0191h			
0192h			
0193h			
0194h			
0195h			
0196h			
0197h			
0198h			
0199h			
019Ah			
019Bh			
019Ch			
019Dh			
019Eh			
019Fh			

Address	Register	Symbol	Page
01A0h			
01A1h			
01A2h			
01A3h			
01A4h			
01A5h			
01A6h			
01A7h			
01A8h			
01A9h			
01AAh			
01ABh			
01ACh			
01ADh			
01AEh			
01AFh			
01B0h			
01B1h			
01B2h			
01B3h	Flash Memory Control Register 4	FMR4	405
01B4h			
01B5h	Flash Memory Control Register 1	FMR1	404
01B6h			
01B7h	Flash Memory Control Register 0	FMR0	403
01B8h			
01B9h			
01BAh			
01BBh			
01BCh			
01BDh			
01BEh			
FFFh	Option Function Select Register	OFS	27, 127, 398

NOTE:

1. The blank regions are reserved. Do not access locations in these regions.

1. Overview

These MCUs are fabricated using a high-performance silicon gate CMOS process, embedding the R8C/Tiny Series CPU core, and are packaged in a 52-pin molded-plastic LQFP or a 64-pin molded-plastic FLGA. It implements sophisticated instructions for a high level of instruction efficiency. With 1 Mbyte of address space, they are capable of executing instructions at high speed.

Furthermore, the R8C/25 Group has on-chip data flash (1 KB x 2 blocks).

The difference between the R8C/24 Group and R8C/25 Group is only the presence or absence of data flash. Their peripheral functions are the same.

1.1 Applications

Electronic household appliances, office equipment, audio equipment, consumer products, etc.

1.2 Performance Overview

Table 1.1 outlines the Functions and Specifications for R8C/24 Group and Table 1.2 outlines the Functions and Specifications for R8C/25 Group.

Table 1.1 Functions and Specifications for R8C/24 Group

	Item	Specification
CPU	Number of fundamental instructions	89 instructions
	Minimum instruction execution time	50 ns (f(XIN) = 20 MHz, VCC = 3.0 to 5.5 V) 100 ns (f(XIN) = 10 MHz, VCC = 2.7 to 5.5 V) 200 ns (f(XIN) = 5 MHz, VCC = 2.2 to 5.5 V)
	Operating mode	Single-chip
	Address space	1 Mbyte
	Memory capacity	Refer to Table 1.3 Product Information for R8C/24 Group
Peripheral Functions	Ports	I/O ports: 41 pins, Input port: 3 pins
	LED drive ports	I/O ports: 8 pins
	Timers	Timer RA: 8 bits × 1 channel Timer RB: 8 bits × 1 channel (Each timer equipped with 8-bit prescaler) Timer RD: 16 bits × 2 channels (Input capture and output compare circuits) Timer RE: With real-time clock and compare match function
	Serial interfaces	2 channels (UART0, UART1) Clock synchronous serial I/O, UART
	Clock synchronous serial interface	1 channel I ² C bus Interface ⁽¹⁾ Clock synchronous serial I/O with chip select
	LIN module	Hardware LIN: 1 channel (timer RA, UART0)
	A/D converter	10-bit A/D converter: 1 circuit, 12 channels
	Watchdog timer	15 bits × 1 channel (with prescaler) Reset start selectable
	Interrupts	Internal: 11 sources, External: 5 sources, Software: 4 sources, Priority levels: 7 levels
	Clock generation circuits	3 circuits <ul style="list-style-type: none"> XIN clock generation circuit (with on-chip feedback resistor) On-chip oscillator (high speed, low speed) High-speed on-chip oscillator has a frequency adjustment function XCIN clock generation circuit (32 kHz)
	Oscillation stop detection function	XIN clock oscillation stop detection function
	Voltage detection circuit	On-chip
	Power-on reset circuit	On-chip
Electrical Characteristics	Supply voltage	VCC = 3.0 to 5.5 V (f(XIN) = 20 MHz) VCC = 2.7 to 5.5 V (f(XIN) = 10 MHz) VCC = 2.2 to 5.5 V (f(XIN) = 5 MHz)
	Current consumption	Typ. 10 mA (VCC = 5.0 V, f(XIN) = 20 MHz) Typ. 6 mA (VCC = 3.0 V, f(XIN) = 10 MHz) Typ. 2.0 μA (VCC = 3.0 V, wait mode (f(XCIN) = 32 kHz)) Typ. 0.7 μA (VCC = 3.0 V, stop mode)
Flash Memory	Programming and erasure voltage	VCC = 2.7 to 5.5 V
	Programming and erasure endurance	100 times
Operating Ambient Temperature		-20 to 85°C (N version)
		-40 to 85°C (D version) ⁽²⁾
		-20 to 105°C (Y version) ⁽³⁾
Package		52-pin molded-plastic LQFP
		64-pin molded-plastic FLGA

NOTES:

- I²C bus is a trademark of Koninklijke Philips Electronics N. V.
- Specify the D version if D version functions are to be used.
- Please contact Renesas Technology sales offices for the Y version.

Table 1.2 Functions and Specifications for R8C/25 Group

	Item	Specification
CPU	Number of fundamental instructions	89 instructions
	Minimum instruction execution time	50 ns (f(XIN) = 20 MHz, VCC = 3.0 to 5.5 V) 100 ns (f(XIN) = 10 MHz, VCC = 2.7 to 5.5 V) 200 ns (f(XIN) = 5 MHz, VCC = 2.2 to 5.5 V)
	Operating mode	Single-chip
	Address space	1 Mbyte
	Memory capacity	Refer to Table 1.4 Product Information for R8C/25 Group
Peripheral Functions	Ports	I/O ports: 41 pins, Input port: 3 pins
	LED drive ports	I/O ports: 8 pins
	Timers	Timer RA: 8 bits × 1 channel Timer RB: 8 bits × 1 channel (Each timer equipped with 8-bit prescaler) Timer RD: 16 bits × 2 channels (Input capture and output compare circuits) Timer RE: With real-time clock and compare match function
	Serial interface	2 channels (UART0, UART1) Clock synchronous serial I/O, UART
	Clock synchronous serial interface	1 channel I ² C bus Interface ⁽¹⁾ Clock synchronous serial I/O with chip select
	LIN module	Hardware LIN: 1 channel (timer RA, UART0)
	A/D converter	10-bit A/D converter: 1 circuit, 12 channels
	Watchdog timer	15 bits × 1 channel (with prescaler) Reset start selectable
	Interrupts	Internal: 11 sources, External: 5 sources, Software: 4 sources, Priority levels: 7 levels
	Clock generation circuits	3 circuits <ul style="list-style-type: none"> • XIN clock generation circuit (with on-chip feedback resistor) • On-chip oscillator (high speed, low speed) High-speed on-chip oscillator has a frequency adjustment function • XCIN clock generation circuit (32 kHz)
	Oscillation stop detection function	XIN clock oscillation stop detection function
	Voltage detection circuit	On-chip
	Power-on reset circuit	On-chip
	Electrical Characteristics	Supply voltage
Current consumption		Typ. 10 mA (VCC = 5.0 V, f(XIN) = 20 MHz) Typ. 6 mA (VCC = 3.0 V, f(XIN) = 10 MHz) Typ. 2.0 μA (VCC = 3.0 V, wait mode (f(XCIN) = 32 kHz)) Typ. 0.7 μA (VCC = 3.0 V, stop mode)
Flash memory	Programming and erasure voltage	VCC = 2.7 to 5.5 V
	Programming and erasure endurance	1,0000 times (data flash) 1,000 times (program ROM)
Operating Ambient Temperature		-20 to 85°C (N version)
		-40 to 85°C (D version) ⁽²⁾
		-20 to 105°C (Y version) ⁽³⁾
Package		52-pin molded-plastic LQFP
		64-pin molded-plastic FLGA

NOTES:

1. I²C bus is a trademark of Koninklijke Philips Electronics N. V.
2. Specify the D version if D version functions are to be used.
3. Please contact Renesas Technology sales offices for the Y version.

1.3 Block Diagram

Figure 1.1 shows a Block Diagram.

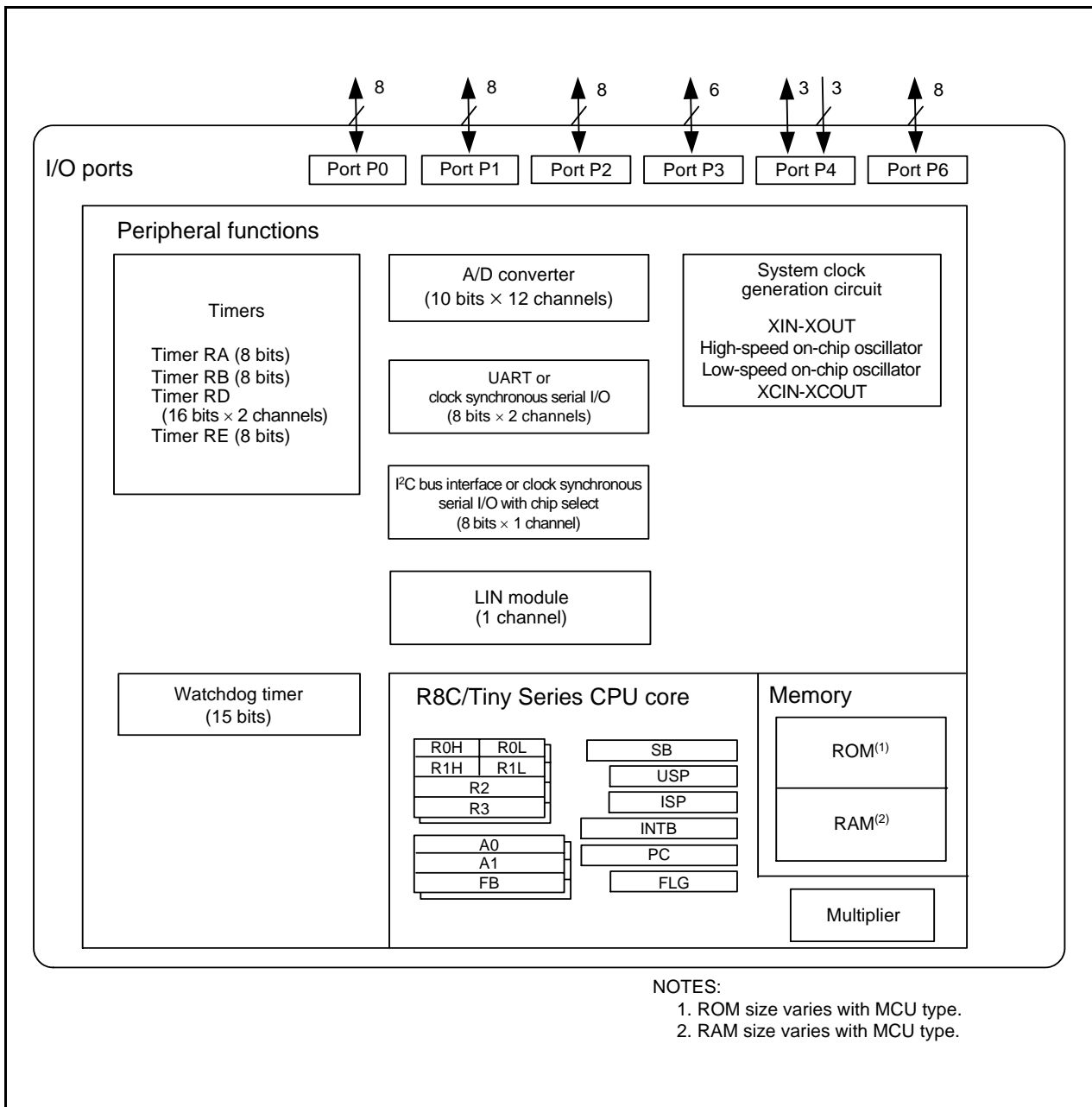

Figure 1.1 Block Diagram

1.4 Product Information

Table 1.3 lists Product Information for R8C/24 Group and Table 1.4 lists Product Information for R8C/25 Group.

Table 1.3 Product Information for R8C/24 Group

Current of Nov. 2006

Type No.	ROM Capacity	RAM Capacity	Package Type	Remarks
R5F21244SNFP	16 Kbytes	1 Kbyte	PLQP0052JA-A	N version Blank product
R5F21245SNFP	24 Kbytes	2 Kbytes	PLQP0052JA-A	
R5F21246SNFP	32 Kbytes	2 Kbytes	PLQP0052JA-A	
R5F21247SNFP	48 Kbytes	2.5 Kbytes	PLQP0052JA-A	
R5F21248SNFP	64 Kbytes	3 Kbytes	PLQP0052JA-A	
R5F21244SNLG	16 Kbytes	1 Kbyte	PTLG0064JA-A	
R5F21246SNLG	32 Kbytes	2 Kbytes	PTLG0064JA-A	
R5F21244SDFP	16 Kbytes	1 Kbyte	PLQP0052JA-A	D version Blank product
R5F21245SDFP	24 Kbytes	2 Kbytes	PLQP0052JA-A	
R5F21246SDFP	32 Kbytes	2 Kbytes	PLQP0052JA-A	
R5F21247SDFP	48 Kbytes	2.5 Kbytes	PLQP0052JA-A	
R5F21248SDFP	64 Kbytes	3 Kbytes	PLQP0052JA-A	
R5F21244SNXXXFP	16 Kbytes	1 Kbyte	PLQP0052JA-A	N version Factory programming product ⁽¹⁾
R5F21245SNXXXFP	24 Kbytes	2 Kbytes	PLQP0052JA-A	
R5F21246SNXXXFP	32 Kbytes	2 Kbytes	PLQP0052JA-A	
R5F21247SNXXXFP(D)	48 Kbytes	2.5 Kbytes	PLQP0052JA-A	
R5F21248SNXXXFP(D)	64 Kbytes	3 Kbytes	PLQP0052JA-A	
R5F21244SNXXXLG(D)	16 Kbytes	1 Kbyte	PTLG0064JA-A	
R5F21246SNXXXLG(D)	32 Kbytes	2 Kbytes	PTLG0064JA-A	D version Factory programming product ⁽¹⁾
R5F21244SDXXXFP	16 Kbytes	1 Kbyte	PLQP0052JA-A	
R5F21245SDXXXFP	24 Kbytes	2 Kbytes	PLQP0052JA-A	
R5F21246SDXXXFP	32 Kbytes	2 Kbytes	PLQP0052JA-A	
R5F21247SDXXXFP(D)	48 Kbytes	2.5 Kbytes	PLQP0052JA-A	
R5F21248SDXXXFP(D)	64 Kbytes	3 Kbytes	PLQP0052JA-A	

(D): Under Development

NOTE:

1. The user ROM is programmed before shipment.

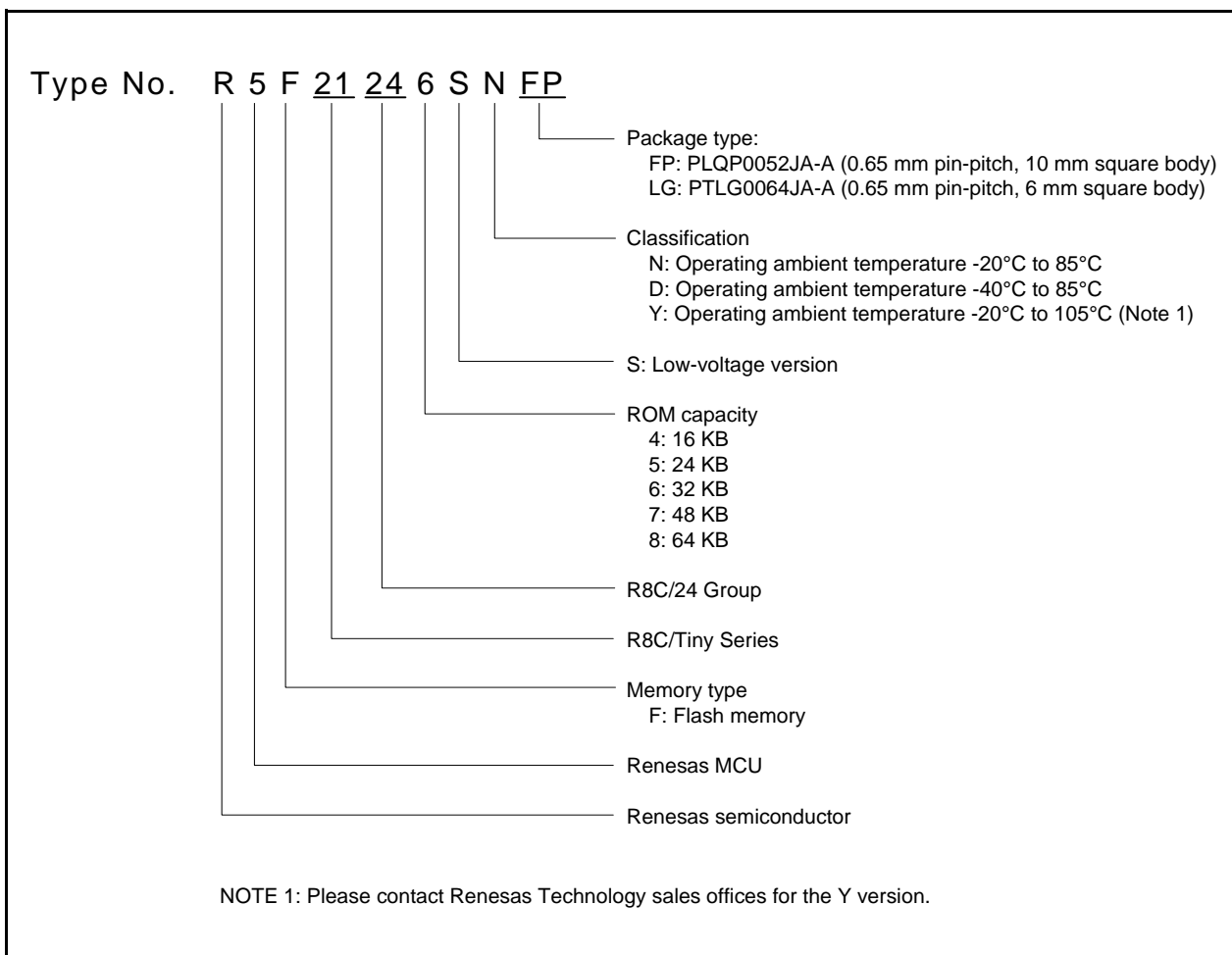

Figure 1.2 Type Number, Memory Size, and Package of R8C/24 Group

Table 1.4 Product Information for R8C/25 Group **Current of Nov. 2006**

Type No.	ROM Capacity		RAM Capacity	Package Type	Remarks
	Program ROM	Data flash			
R5F21254SNFP	16 Kbytes	1 Kbyte × 2	1 Kbyte	PLQP0052JA-A	N version Blank product
R5F21255SNFP	24 Kbytes	1 Kbyte × 2	2 Kbytes	PLQP0052JA-A	
R5F21256SNFP	32 Kbytes	1 Kbyte × 2	2 Kbytes	PLQP0052JA-A	
R5F21257SNFP	48 Kbytes	1 Kbyte × 2	2.5 Kbytes	PLQP0052JA-A	
R5F21258SNFP	64 Kbytes	1 Kbyte × 2	3 Kbytes	PLQP0052JA-A	
R5F21254SNLG	16 Kbytes	1 Kbyte × 2	1 Kbyte	PTLG0064JA-A	
R5F21256SNLG	32 Kbytes	1 Kbyte × 2	2 Kbytes	PTLG0064JA-A	D version Blank product
R5F21254SDFP	16 Kbytes	1 Kbyte × 2	1 Kbyte	PLQP0052JA-A	
R5F21255SDFP	24 Kbytes	1 Kbyte × 2	2 Kbytes	PLQP0052JA-A	
R5F21256SDFP	32 Kbytes	1 Kbyte × 2	2 Kbytes	PLQP0052JA-A	
R5F21257SDFP	48 Kbytes	1 Kbyte × 2	2.5 Kbytes	PLQP0052JA-A	
R5F21258SDFP	64 Kbytes	1 Kbyte × 2	3 Kbytes	PLQP0052JA-A	
R5F21254SNXXXFP	16 Kbytes	1 Kbyte × 2	1 Kbyte	PLQP0052JA-A	N version Factory programming product ⁽¹⁾
R5F21255SNXXXFP	24 Kbytes	1 Kbyte × 2	2 Kbytes	PLQP0052JA-A	
R5F21256SNXXXFP	32 Kbytes	1 Kbyte × 2	2 Kbytes	PLQP0052JA-A	
R5F21257SNXXXFP(D)	48 Kbytes	1 Kbyte × 2	2.5 Kbytes	PLQP0052JA-A	
R5F21258SNXXXFP(D)	64 Kbytes	1 Kbyte × 2	3 Kbytes	PLQP0052JA-A	
R5F21254SNXXXLG(D)	16 Kbytes	1 Kbyte × 2	1 Kbyte	PTLG0064JA-A	
R5F21256SNXXXLG(D)	32 Kbytes	1 Kbyte × 2	2 Kbytes	PTLG0064JA-A	D version Factory programming product ⁽¹⁾
R5F21254SDXXXFP	16 Kbytes	1 Kbyte × 2	1 Kbyte	PLQP0052JA-A	
R5F21255SDXXXFP	24 Kbytes	1 Kbyte × 2	2 Kbytes	PLQP0052JA-A	
R5F21256SDXXXFP	32 Kbytes	1 Kbyte × 2	2 Kbytes	PLQP0052JA-A	
R5F21257SDXXXFP(D)	48 Kbytes	1 Kbyte × 2	2.5 Kbytes	PLQP0052JA-A	
R5F21258SDXXXFP(D)	64 Kbytes	1 Kbyte × 2	3 Kbytes	PLQP0052JA-A	

(D): Under Development

NOTE:

1. The user ROM is programmed before shipment.

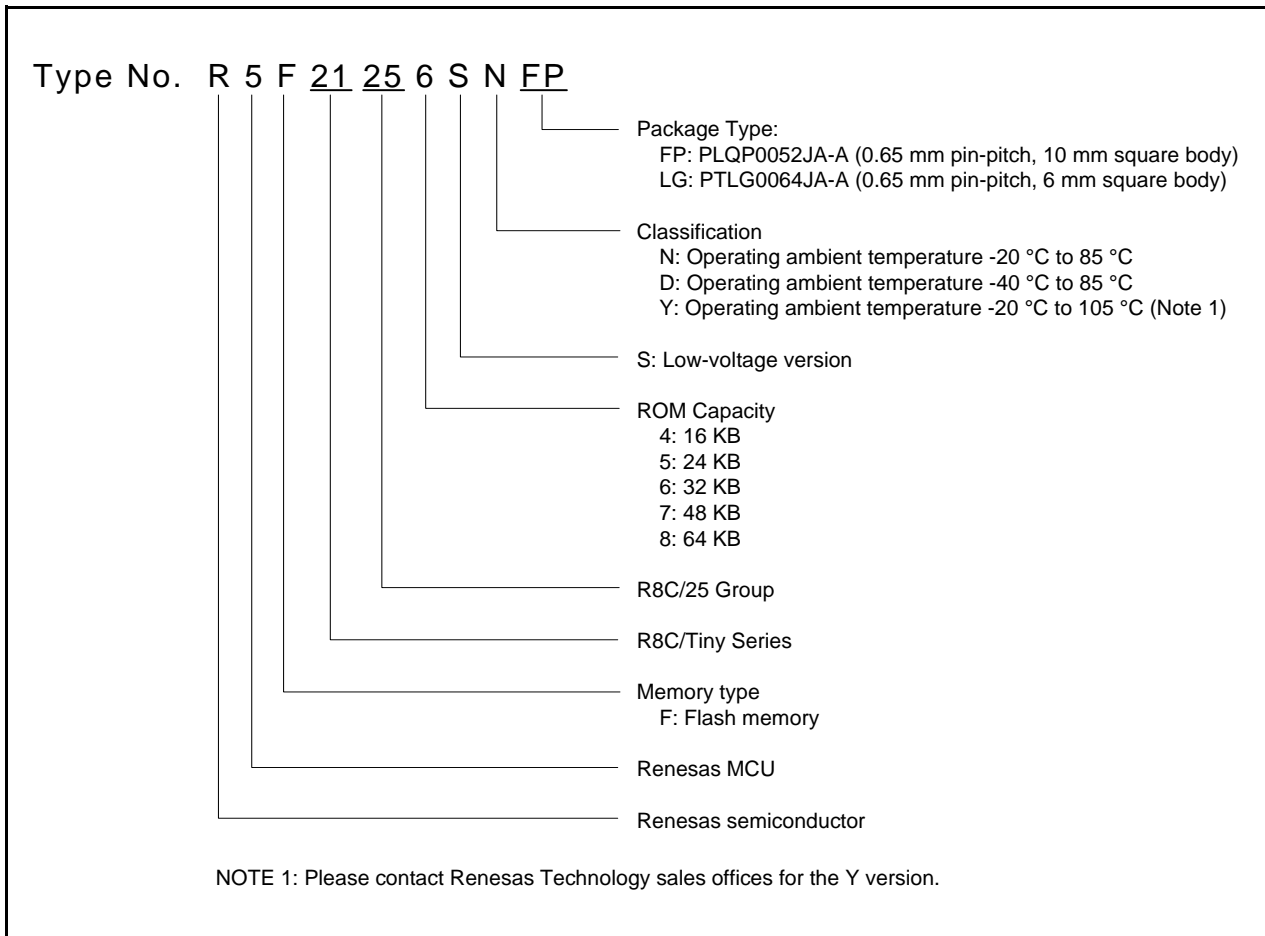

Figure 1.3 Type Number, Memory Size, and Package of R8C/25 Group

1.5 Pin Assignments

Figure 1.4 shows PLQP0052JA-A Package Pin Assignments (Top View). Figure 1.5 shows PTLG0064JA-A Package Pin Assignments.

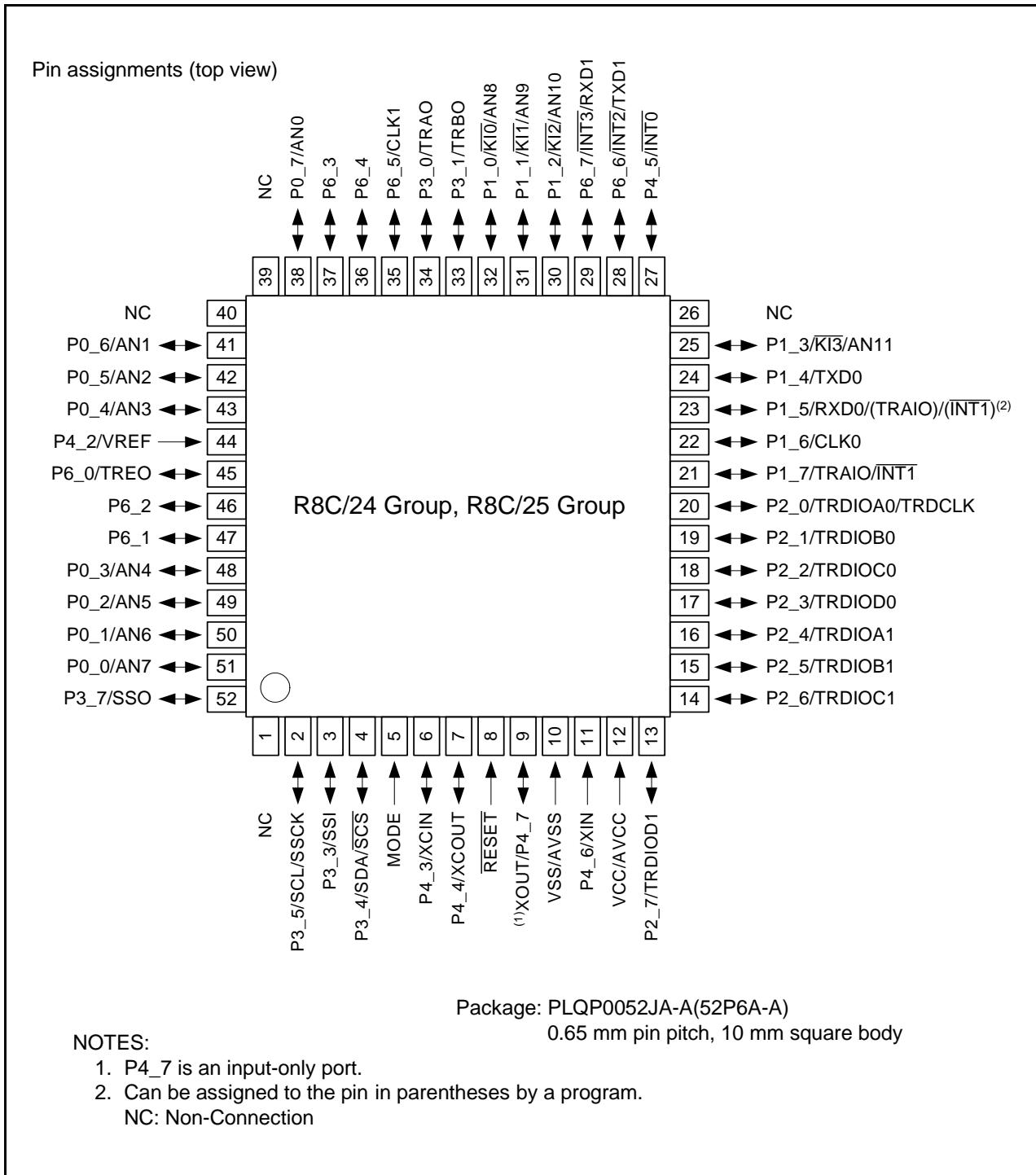

Figure 1.4 PLQP0052JA-A Package Pin Assignments (Top View)

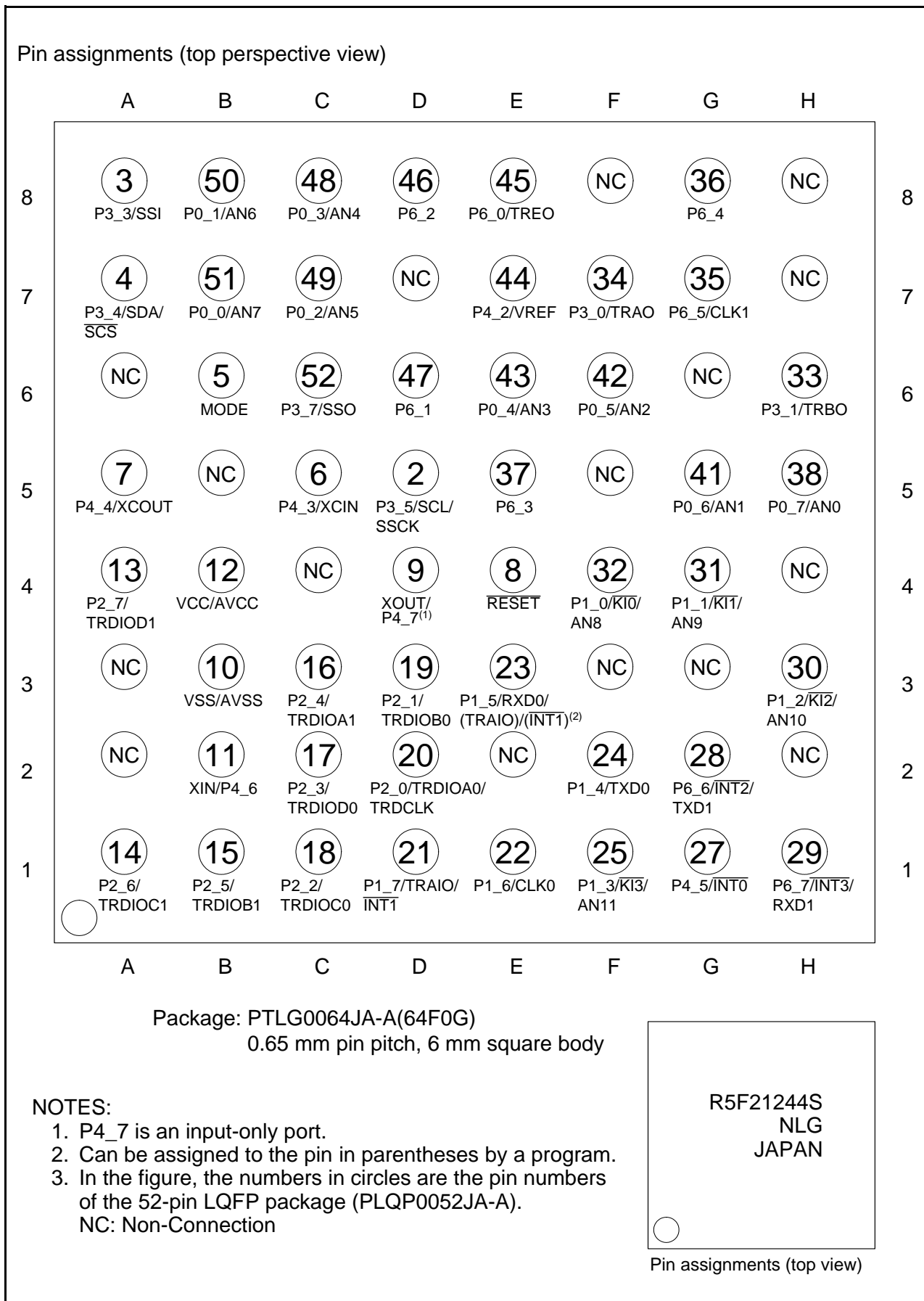

Figure 1.5 PTLG0064JA-A Package Pin Assignments

1.6 Pin Functions

Table 1.5 lists Pin Functions.

Table 1.5 Pin Functions

Type	Symbol	I/O Type	Description
Power supply input	VCC, VSS	I	Apply 2.2 V to 5.5 V to the VCC pin. Apply 0 V to the VSS pin.
Analog power supply input	AVCC, AVSS	I	Power supply for the A/D converter. Connect a capacitor between AVCC and AVSS.
Reset input	$\overline{\text{RESET}}$	I	Input "L" on this pin resets the MCU.
MODE	MODE	I	Connect this pin to VCC via a resistor.
XIN clock input	XIN	I	These pins are provided for XIN clock generation circuit I/O. Connect a ceramic resonator or a crystal oscillator between the XIN and XOUT pins. To use an external clock, input it to the XIN pin and leave the XOUT pin open.
XIN clock output	XOUT	O	
XCIN clock input	XCIN	I	These pins are provided for XCIN clock generation circuit I/O. Connect a crystal oscillator between the XCIN and XCOU pins. To use an external clock, input it to the XCIN pin and leave the XCOU pin open.
XCIN clock output	XCOU	O	
$\overline{\text{INT}}$ interrupt input	$\overline{\text{INT0}}$ to $\overline{\text{INT3}}$	I	$\overline{\text{INT}}$ interrupt input pins. $\overline{\text{INT0}}$ is timer RD input pin. $\overline{\text{INT1}}$ is timer RA input pin.
Key input interrupt	$\overline{\text{KI0}}$ to $\overline{\text{KI3}}$	I	Key input interrupt input pins
Timer RA	TRAIO	I/O	Timer RA I/O pin
	TRAO	O	Timer RA output pin
Timer RB	TRBO	O	Timer RB output pin
Timer RD	TRDIOA0, TRDIOA1, TRDIOB0, TRDIOB1, TRDIOC0, TRDIOC1, TRDIOD0, TRDIOD1	I/O	Timer RD I/O ports
	TRDCLK	I	External clock input pin
Timer RE	TREO	O	Divided clock output pin
Serial interface	CLK0, CLK1	I/O	Transfer clock I/O pin
	RXD0, RXD1	I	Serial data input pins
	TXD0, TXD1	O	Serial data output pins
I ² C bus interface	SCL	I/O	Clock I/O pin
	SDA	I/O	Data I/O pin
Clock synchronous serial I/O with chip select	SSI	I/O	Data I/O pin
	$\overline{\text{SCS}}$	I/O	Chip-select signal I/O pin
	SSCK	I/O	Clock I/O pin
	SSO	I/O	Data I/O pin
Reference voltage input	VREF	I	Reference voltage input pin to A/D converter
A/D converter	AN0 to AN11	I	Analog input pins to A/D converter
I/O port	P0_0 to P0_7, P1_0 to P1_7, P2_0 to P2_7, P3_0, P3_1, P3_3 to P3_5, P3_7, P4_3 to P4_5, P6_0 to P6_7	I/O	CMOS I/O ports. Each port has an I/O select direction register, allowing each pin in the port to be directed for input or output individually. Any port set to input can be set to use a pull-up resistor or not by a program. P2_0 to P2_7 also function as LED drive ports.
Input port	P4_2, P4_6, P4_7	I	Input-only ports

I: Input O: Output I/O: Input and output

Table 1.6 Pin Name Information by Pin Number

Pin Number	Control Pin	Port	I/O Pin Functions for of Peripheral Modules					
			Interrupt	Timer	Serial Interface	Clock Synchronous Serial I/O with Chip Select	I ² C bus Interface	A/D Converter
2		P3_5				SSCK	SCL	
3		P3_3				SSI		
4		P3_4				SCS	SDA	
5	MODE							
6	XCIN	P4_3						
7	XCOU	P4_4						
8	RESET							
9	XOUT	P4_7						
10	VSS/AVSS							
11	XIN	P4_6						
12	VCC/AVCC							
13		P2_7		TRDIOD1				
14		P2_6		TRDIOC1				
15		P2_5		TRDIOB1				
16		P2_4		TRDIOA1				
17		P2_3		TRDIOD0				
18		P2_2		TRDIOC0				
19		P2_1		TRDIOB0				
20		P2_0		TRDIOA0/TRDCLK				
21		P1_7	INT1	TRAIO				
22		P1_6			CLK0			
23		P1_5	(INT1) ⁽¹⁾	(TRAIO) ⁽¹⁾	RXD0			
24		P1_4			TXD0			
25		P1_3	K3					AN11
27		P4_5	INT0	INT0				
28		P6_6	INT2		TXD1			
29		P6_7	INT3		RXD1			
30		P1_2	K2					AN10
31		P1_1	K1					AN9
32		P1_0	K0					AN8
33		P3_1		TRBO				
34		P3_0		TRA0				
35		P6_5			CLK1			
36		P6_4						
37		P6_3						
38		P0_7						AN0
41		P0_6						AN1
42		P0_5						AN2
43		P0_4						AN3
44	VREF	P4_2						
45		P6_0		TRE0				
46		P6_2						
47		P6_1						
48		P0_3						AN4
49		P0_2						AN5
50		P0_1						AN6
51		P0_0						AN7
52		P3_7				SSO		

NOTE:

1. Can be assigned to the pin in parentheses by a program.

2. Central Processing Unit (CPU)

Figure 2.1 shows the CPU Registers. The CPU contains 13 registers. R0, R1, R2, R3, A0, A1, and FB configure a register bank. There are two sets of register bank.

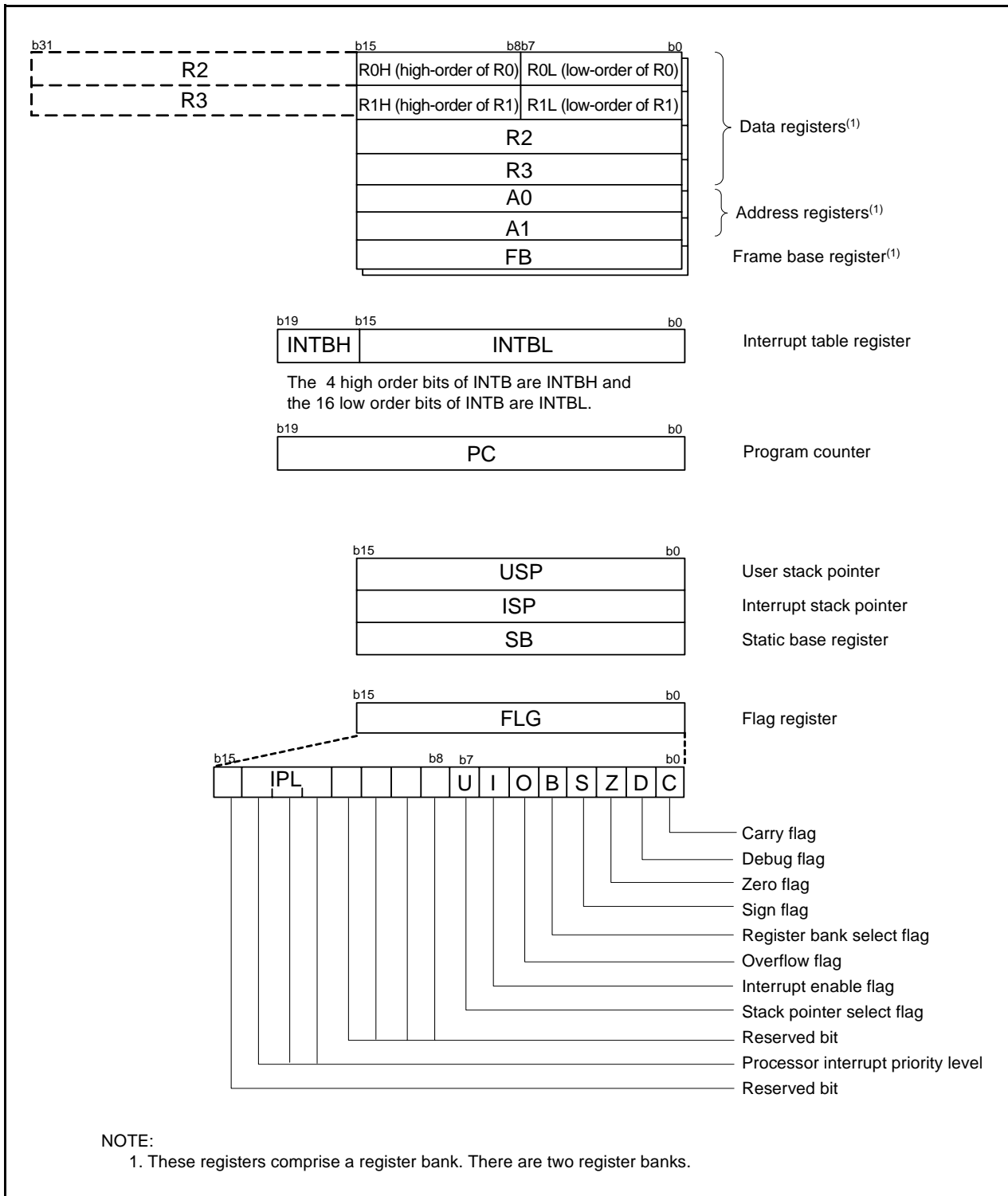

Figure 2.1 CPU Registers

2.1 Data Registers (R0, R1, R2, and R3)

R0 is a 16-bit register for transfer, arithmetic, and logic operations. The same applies to R1 to R3. R0 can be split into high-order bits (R0H) and low-order bits (R0L) to be used separately as 8-bit data registers. R1H and R1L are analogous to R0H and R0L. R2 can be combined with R0 and used as a 32-bit data register (R2R0). R3R1 is analogous to R2R0.

2.2 Address Registers (A0 and A1)

A0 is a 16-bit register for address register indirect addressing and address register relative addressing. It is also used for transfer, arithmetic, and logic operations. A1 is analogous to A0. A1 can be combined with A0 and as a 32-bit address register (A1A0).

2.3 Frame Base Register (FB)

FB is a 16-bit register for FB relative addressing.

2.4 Interrupt Table Register (INTB)

INTB is a 20-bit register that indicates the start address of an interrupt vector table.

2.5 Program Counter (PC)

PC is 20 bits wide and indicates the address of the next instruction to be executed.

2.6 User Stack Pointer (USP) and Interrupt Stack Pointer (ISP)

The stack pointers (SP), USP, and ISP, are each 16 bits wide. The U flag of FLG is used to switch between USP and ISP.

2.7 Static Base Register (SB)

SB is a 16-bit register for SB relative addressing.

2.8 Flag Register (FLG)

FLG is an 11-bit register indicating the CPU state.

2.8.1 Carry Flag (C)

The C flag retains carry, borrow, or shift-out bits that have been generated by the arithmetic and logic unit.

2.8.2 Debug Flag (D)

The D flag is for debugging only. Set it to 0.

2.8.3 Zero Flag (Z)

The Z flag is set to 1 when an arithmetic operation results in 0; otherwise to 0.

2.8.4 Sign Flag (S)

The S flag is set to 1 when an arithmetic operation results in a negative value; otherwise to 0.

2.8.5 Register Bank Select Flag (B)

Register bank 0 is selected when the B flag is 0. Register bank 1 is selected when this flag is set to 1.

2.8.6 Overflow Flag (O)

The O flag is set to 1 when an operation results in an overflow; otherwise to 0.

2.8.7 Interrupt Enable Flag (I)

The I flag enables maskable interrupts.

Interrupt are disabled when the I flag is set to 0, and are enabled when the I flag is set to 1. The I flag is set to 0 when an interrupt request is acknowledged.

2.8.8 Stack Pointer Select Flag (U)

ISP is selected when the U flag is set to 0; USP is selected when the U flag is set to 1.

The U flag is set to 0 when a hardware interrupt request is acknowledged or the INT instruction of software interrupt numbers 0 to 31 is executed.

2.8.9 Processor Interrupt Priority Level (IPL)

IPL is 3 bits wide and assigns processor interrupt priority levels from level 0 to level 7.

If a requested interrupt has higher priority than IPL, the interrupt is enabled.

2.8.10 Reserved Bit

If necessary, set to 0. When read, the content is undefined.

3. Memory

3.1 R8C/24 Group

Figure 3.1 is a Memory Map of R8C/24 Group. The R8C/24 group has 1 Mbyte of address space from addresses 00000h to FFFFFh.

The internal ROM is allocated lower addresses, beginning with address 0FFFFh. For example, a 48-Kbyte internal ROM area is allocated addresses 04000h to 0FFFFh.

The fixed interrupt vector table is allocated addresses 0FFDCh to 0FFFFh. They store the starting address of each interrupt routine.

The internal RAM is allocated higher addresses, beginning with address 00400h. For example, a 2-Kbyte internal RAM area is allocated addresses 00400h to 00BFFh. The internal RAM is used not only for storing data but also for calling subroutines and as stacks when interrupt requests are acknowledged.

Special function registers (SFRs) are allocated addresses 00000h to 002FFh. The peripheral function control registers are allocated here. All addresses within the SFR, which have nothing allocated are reserved for future use and cannot be accessed by users.

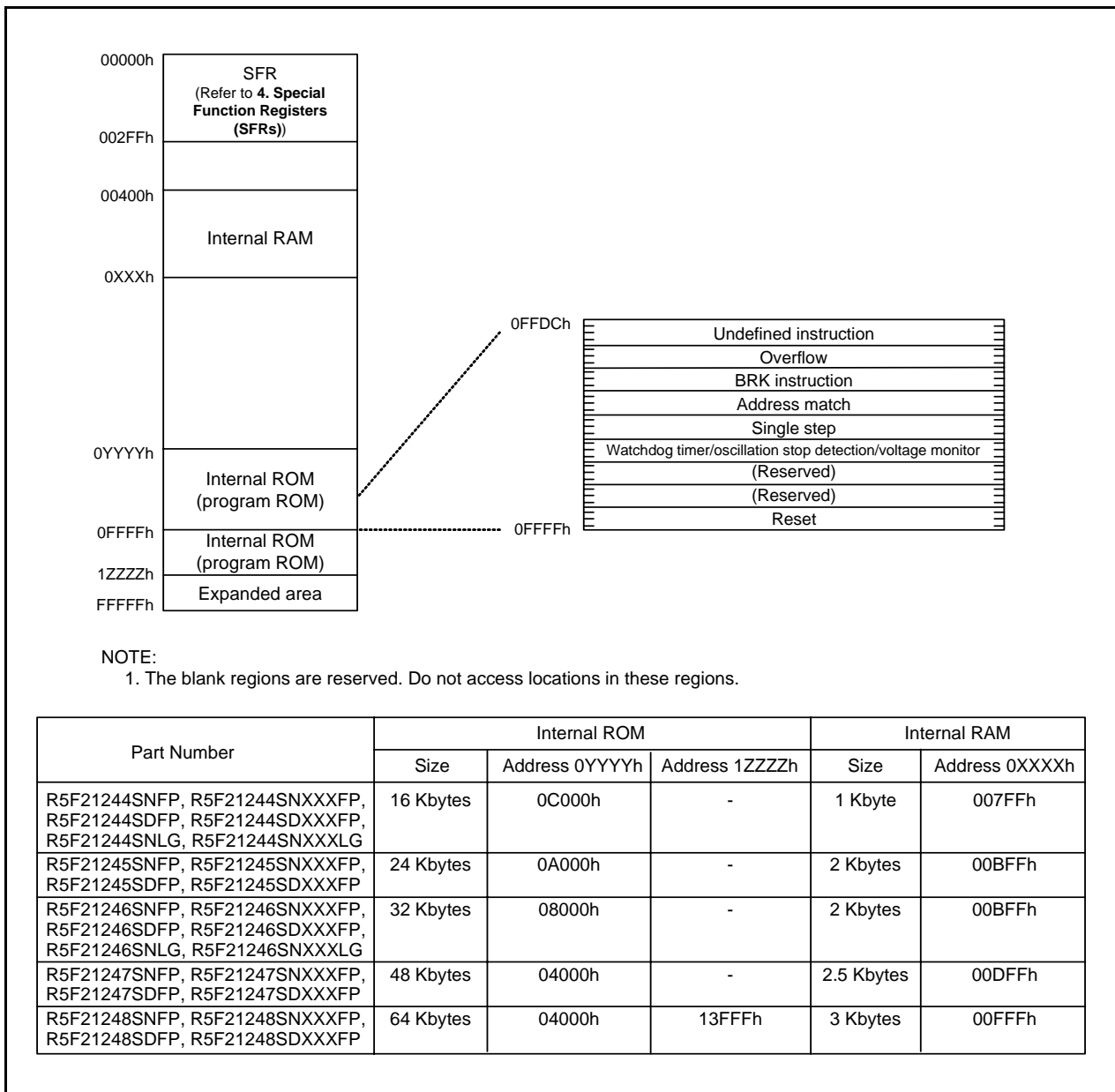

Figure 3.1 Memory Map of R8C/24 Group

3.2 R8C/25 Group

Figure 3.2 is a Memory Map of R8C/25 Group. The R8C/25 group has 1 Mbyte of address space from addresses 00000h to FFFFFh.

The internal ROM (program ROM) is allocated lower addresses, beginning with address 0FFFFh. For example, a 48-Kbyte internal ROM area is allocated addresses 04000h to 0FFFFh.

The fixed interrupt vector table is allocated addresses 0FFDCh to 0FFFFh. They store the starting address of each interrupt routine.

The internal ROM (data flash) is allocated addresses 02400h to 02BFFh.

The internal RAM area is allocated higher addresses, beginning with address 00400h. For example, a 2-Kbyte internal RAM is allocated addresses 00400h to 00BFFh. The internal RAM is used not only for storing data but also for calling subroutines and as stacks when interrupt requests are acknowledged.

Special function registers (SFRs) are allocated addresses 00000h to 002FFh. The peripheral function control registers are allocated here. All addresses within the SFR, which have nothing allocated are reserved for future use and cannot be accessed by users.

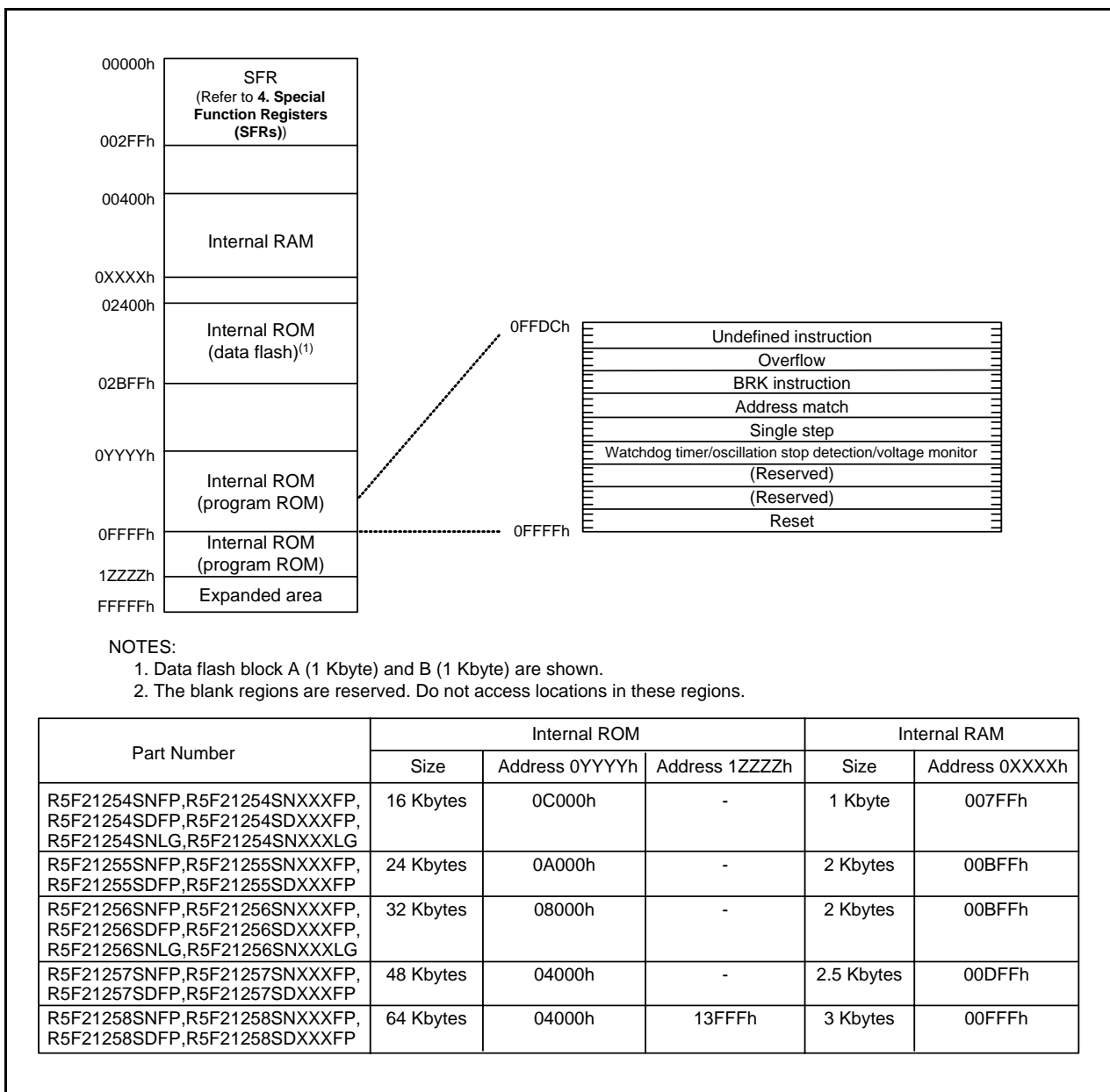

Figure 3.2 Memory Map of R8C/25 Group

4. Special Function Registers (SFRs)

An SFR (special function register) is a control register for a peripheral function. Tables 4.1 to 4.7 list the special function registers.

Table 4.1 SFR Information (1)(1)

Address	Register	Symbol	After reset
0000h			
0001h			
0002h			
0003h			
0004h	Processor Mode Register 0	PM0	00h
0005h	Processor Mode Register 1	PM1	00h
0006h	System Clock Control Register 0	CM0	01101000b
0007h	System Clock Control Register 1	CM1	00100000b
0008h			
0009h			
000Ah	Protect Register	PRCR	00h
000Bh			
000Ch	Oscillation Stop Detection Register	OCD	00000100b
000Dh	Watchdog Timer Reset Register	WDTR	XXh
000Eh	Watchdog Timer Start Register	WDTS	XXh
000Fh	Watchdog Timer Control Register	WDC	00X11111b
0010h	Address Match Interrupt Register 0	RMAD0	00h
0011h			00h
0012h			00h
0013h	Address Match Interrupt Enable Register	AIER	00h
0014h	Address Match Interrupt Register 1	RMAD1	00h
0015h			00h
0016h			00h
0017h			00h
0018h			
0019h			
001Ah			
001Bh			
001Ch	Count Source Protection Mode Register	CSPR	00h 10000000b ⁽⁶⁾
001Dh			
001Eh			
001Fh			
0020h			
0021h			
0022h			
0023h	High-Speed On-Chip Oscillator Control Register 0	FRA0	00h
0024h	High-Speed On-Chip Oscillator Control Register 1	FRA1	When shipping
0025h	High-Speed On-Chip Oscillator Control Register 2	FRA2	00h
0026h			
0027h			
0028h	Clock Prescaler Reset Flag	CPSRF	00h
0029h	High-Speed On-Chip Oscillator Control Register 4	FRA4	When shipping
002Ah			
002Bh	High-Speed On-Chip Oscillator Control Register 6	FRA6	When shipping
0030h			
0031h	Voltage Detection Register 1 ⁽²⁾	VCA1	00001000b
0032h	Voltage Detection Register 2 ⁽²⁾	VCA2	00h ⁽³⁾ 00100000b ⁽⁴⁾
0033h			
0034h			
0035h			
0036h	Voltage Monitor 1 Circuit Control Register ⁽⁵⁾	VW1C	00001000b
0037h	Voltage Monitor 2 Circuit Control Register ⁽⁵⁾	VW2C	00h
0038h	Voltage Monitor 0 Circuit Control Register ⁽²⁾	VW0C	0000X000b ⁽³⁾ 0100X001b ⁽⁴⁾
0039h			
003Ah			
003Bh			
003Ch			
003Dh			
003Eh			
003Fh			

X: Undefined

NOTES:

- The blank regions are reserved. Do not access locations in these regions.
- Software reset, watchdog timer reset, and voltage monitor 1 reset or voltage monitor 2 reset do not affect this register.
- The LVD00N bit in the OFS register is set to 1 and hardware reset.
- Power-on reset, voltage monitor 0 reset or the LVD00N bit in the OFS register is set to 0, and hardware reset.
- Software reset, watchdog timer reset, and voltage monitor 1 reset or voltage monitor 2 reset do not affect b2 and b3.
- The CSPROINI bit in the OFS register is set to 0.

Table 4.2 SFR Information (2)(1)

Address	Register	Symbol	After reset
0040h			
0041h			
0042h			
0043h			
0044h			
0045h			
0046h			
0047h			
0048h	Timer RD0 Interrupt Control Register	TRD0IC	XXXXX000b
0049h	Timer RD1 Interrupt Control Register	TRD1IC	XXXXX000b
004Ah	Timer RE Interrupt Control Register	TREIC	XXXXX000b
004Bh			
004Ch			
004Dh	Key Input Interrupt Control Register	KUPIC	XXXXX000b
004Eh	A/D Conversion Interrupt Control Register	ADIC	XXXXX000b
004Fh	SSU/IIC Interrupt Control Register ⁽²⁾	SSUIC / IICIC	XXXXX000b
0050h			
0051h	UART0 Transmit Interrupt Control Register	S0TIC	XXXXX000b
0052h	UART0 Receive Interrupt Control Register	S0RIC	XXXXX000b
0053h	UART1 Transmit Interrupt Control Register	S1TIC	XXXXX000b
0054h	UART1 Receive Interrupt Control Register	S1RIC	XXXXX000b
0055h	INT2 Interrupt Control Register	INT2IC	XX00X000b
0056h	Timer RA Interrupt Control Register	TRAIC	XXXXX000b
0057h			
0058h	Timer RB Interrupt Control Register	TRBIC	XXXXX000b
0059h	INT1 Interrupt Control Register	INT1IC	XX00X000b
005Ah	INT3 Interrupt Control Register	INT3IC	XX00X000b
005Bh			
005Ch			
005Dh	INT0 Interrupt Control Register	INT0IC	XX00X000b
005Eh			
005Fh			
0060h			
0061h			
0062h			
0063h			
0064h			
0065h			
0066h			
0067h			
0068h			
0069h			
006Ah			
006Bh			
006Ch			
006Dh			
006Eh			
006Fh			
0070h			
0071h			
0072h			
0073h			
0074h			
0075h			
0076h			
0077h			
0078h			
0079h			
007Ah			
007Bh			
007Ch			
007Dh			
007Eh			
007Fh			

X: Undefined

NOTES:

1. The blank regions are reserved. Do not access locations in these regions.
2. Selected by the IICSEL bit in the PMR register.

Table 4.3 SFR Information (3)(1)

Address	Register	Symbol	After reset
0080h			
0081h			
0082h			
0083h			
0084h			
0085h			
0086h			
0087h			
0088h			
0089h			
008Ah			
008Bh			
008Ch			
008Dh			
008Eh			
008Fh			
0090h			
0091h			
0092h			
0093h			
0094h			
0095h			
0096h			
0097h			
0098h			
0099h			
009Ah			
009Bh			
009Ch			
009Dh			
009Eh			
009Fh			
00A0h	UART0 Transmit/Receive Mode Register	U0MR	00h
00A1h	UART0 Bit Rate Register	U0BRG	XXh
00A2h	UART0 Transmit Buffer Register	U0TB	XXh
00A3h			XXh
00A4h	UART0 Transmit/Receive Control Register 0	U0C0	00001000b
00A5h	UART0 Transmit/Receive Control Register 1	U0C1	00000010b
00A6h	UART0 Receive Buffer Register	U0RB	XXh
00A7h			XXh
00A8h	UART1 Transmit/Receive Mode Register	U1MR	00h
00A9h	UART1 Bit Rate Register	U1BRG	XXh
00AAh	UART1 Transmit Buffer Register	U1TB	XXh
00ABh			XXh
00ACh	UART1 Transmit/Receive Control Register 0	U1C0	00001000b
00ADh	UART1 Transmit/Receive Control Register 1	U1C1	00000010b
00AEh	UART1 Receive Buffer Register	U1RB	XXh
00AFh			XXh
00B0h			
00B1h			
00B2h			
00B3h			
00B4h			
00B5h			
00B6h			
00B7h			
00B8h	SS Control Register H / IIC bus Control Register 1 ⁽²⁾	SSCRH / ICCR1	00h
00B9h	SS Control Register L / IIC bus Control Register 2 ⁽²⁾	SSCRL / ICCR2	01111101b
00BAh	SS Mode Register / IIC bus Mode Register ⁽²⁾	SSMR / ICMR	00011000b
00BBh	SS Enable Register / IIC bus Interrupt Enable Register ⁽²⁾	SSER / ICIER	00h
00BCh	SS Status Register / IIC bus Status Register ⁽²⁾	SSSR / ICSR	00h / 0000X000b
00BDh	SS Mode Register 2 / Slave Address Register ⁽²⁾	SSMR2 / SAR	00h
00BEh	SS Transmit Data Register / IIC bus Transmit Data Register ⁽²⁾	SSTDR / ICDRT	FFh
00BFh	SS Receive Data Register / IIC bus Receive Data Register ⁽²⁾	SSRDR / ICDRR	FFh

X: Undefined

NOTES:

1. The blank regions are reserved. Do not access locations in these regions.
2. Selected by the IICSEL bit in the PMR register.

Table 4.4 SFR Information (4)⁽¹⁾

Address	Register	Symbol	After reset
00C0h	A/D Register	AD	XXh
00C1h			XXh
00C2h			
00C3h			
00C4h			
00C5h			
00C6h			
00C7h			
00C8h			
00C9h			
00CAh			
00CBh			
00CCh			
00CDh			
00CEh			
00CFh			
00D0h			
00D1h			
00D2h			
00D3h			
00D4h	A/D Control Register 2	ADCON2	00h
00D5h			
00D6h	A/D Control Register 0	ADCON0	00h
00D7h	A/D Control Register 1	ADCON1	00h
00D8h			
00D9h			
00DAh			
00DBh			
00DCh			
00DDh			
00DEh			
00DFh			
00E0h	Port P0 Register	P0	XXh
00E1h	Port P1 Register	P1	XXh
00E2h	Port P0 Direction Register	PD0	00h
00E3h	Port P1 Direction Register	PD1	00h
00E4h	Port P2 Register	P2	XXh
00E5h	Port P3 Register	P3	XXh
00E6h	Port P2 Direction Register	PD2	00h
00E7h	Port P3 Direction Register	PD3	00h
00E8h	Port P4 Register	P4	XXh
00E9h			
00EAh	Port P4 Direction Register	PD4	00h
00EBh			
00ECh	Port P6 Register	P6	XXh
00EDh			
00EEh	Port P6 Direction Register	PD6	00h
00EFh			
00F0h			
00F1h			
00F2h			
00F3h			
00F4h	Port P2 Drive Capacity Control Register	P2DRR	00h
00F5h	UART1 Function Select Register	U1SR	XXh
00F6h			
00F7h			
00F8h	Port Mode Register	PMR	00h
00F9h	External Input Enable Register	INTEN	00h
00FAh	INT Input Filter Select Register	INTF	00h
00FBh	Key Input Enable Register	KIEN	00h
00FCh	Pull-Up Control Register 0	PUR0	00h
00FDh	Pull-Up Control Register 1	PUR1	XX00XX00b
00FEh			
00FFh			

X: Undefined

NOTE:

1. The blank regions are reserved. Do not access locations in these regions.

Table 4.5 SFR Information (5)(1)

Address	Register	Symbol	After reset
0100h	Timer RA Control Register	TRACR	00h
0101h	Timer RA I/O Control Register	TRAIOC	00h
0102h	Timer RA Mode Register	TRAMR	00h
0103h	Timer RA Prescaler Register	TRAPRE	FFh
0104h	Timer RA Register	TRA	FFh
0105h			
0106h	LIN Control Register	LINCR	00h
0107h	LIN Status Register	LINST	00h
0108h	Timer RB Control Register	TRBCR	00h
0109h	Timer RB One-Shot Control Register	TRBOCR	00h
010Ah	Timer RB I/O Control Register	TRBIOC	00h
010Bh	Timer RB Mode Register	TRBMR	00h
010Ch	Timer RB Prescaler Register	TRBPRE	FFh
010Dh	Timer RB Secondary Register	TRBSC	FFh
010Eh	Timer RB Primary Register	TRBPR	FFh
010Fh			
0110h			
0111h			
0112h			
0113h			
0114h			
0115h			
0116h			
0117h			
0118h	Timer RE Second Data Register / Counter Data Register	TRESEC	00h
0119h	Timer RE Minute Data Register / Compare Data Register	TREMIN	00h
011Ah	Timer RE Hour Data Register	TREHR	00h
011Bh	Timer RE Day of Week Data Register	TREWK	00h
011Ch	Timer RE Control Register 1	TRECR1	00h
011Dh	Timer RE Control Register 2	TRECR2	00h
011Eh	Timer RE Clock Source Select Register	TRECSR	00001000b
011Fh			
0120h			
0121h			
0122h			
0123h			
0124h			
0125h			
0126h			
0127h			
0128h			
0129h			
012Ah			
012Bh			
012Ch			
012Dh			
012Eh			
012Fh			
0130h			
0131h			
0132h			
0133h			
0134h			
0135h			
0136h			
0137h	Timer RD Start Register	TRDSTR	1111100b
0138h	Timer RD Mode Register	TRDMR	00001110b
0139h	Timer RD PWM Mode Register	TRDPMR	10001000b
013Ah	Timer RD Function Control Register	TRDFCR	10000000b
013Bh	Timer RD Output Master Enable Register 1	TRDOER1	FFh
013Ch	Timer RD Output Master Enable Register 2	TRDOER2	01111111b
013Dh	Timer RD Output Control Register	TRDOCR	00h
013Eh	Timer RD Digital Filter Function Select Register 0	TRDDF0	00h
013Fh	Timer RD Digital Filter Function Select Register 1	TRDDF1	00h

X: Undefined

NOTE:

1. The blank regions are reserved. Do not access locations in these regions.

Table 4.6 SFR Information (6)(1)

Address	Register	Symbol	After reset
0140h	Timer RD Control Register 0	TRDCR0	00h
0141h	Timer RD I/O Control Register A0	TRDIORA0	10001000b
0142h	Timer RD I/O Control Register C0	TRDIORC0	10001000b
0143h	Timer RD Status Register 0	TRDSR0	11100000b
0144h	Timer RD Interrupt Enable Register 0	TRDIER0	11100000b
0145h	Timer RD PWM Mode Output Level Control Register 0	TRDPOCR0	11111000b
0146h	Timer RD Counter 0	TRD0	00h
0147h			00h
0148h	Timer RD General Register A0	TRDGRA0	FFh
0149h			FFh
014Ah	Timer RD General Register B0	TRDGRB0	FFh
014Bh			FFh
014Ch	Timer RD General Register C0	TRDGRC0	FFh
014Dh			FFh
014Eh	Timer RD General Register D0	TRDGRD0	FFh
014Fh			FFh
0150h	Timer RD Control Register 1	TRDCR1	00h
0151h	Timer RD I/O Control Register A1	TRDIORA1	10001000b
0152h	Timer RD I/O Control Register C1	TRDIORC1	10001000b
0153h	Timer RD Status Register 1	TRDSR1	11000000b
0154h	Timer RD Interrupt Enable Register 1	TRDIER1	11100000b
0155h	Timer RD PWM Mode Output Level Control Register 1	TRDPOCR1	11111000b
0156h	Timer RD Counter 1	TRD1	00h
0157h			00h
0158h	Timer RD General Register A1	TRDGRA1	FFh
0159h			FFh
015Ah	Timer RD General Register B1	TRDGRB1	FFh
015Bh			FFh
015Ch	Timer RD General Register C1	TRDGRC1	FFh
015Dh			FFh
015Eh	Timer RD General Register D1	TRDGRD1	FFh
015Fh			FFh
0160h			
0161h			
0162h			
0163h			
0164h			
0165h			
0166h			
0167h			
0168h			
0169h			
016Ah			
016Bh			
016Ch			
016Dh			
016Eh			
016Fh			
0170h			
0171h			
0172h			
0173h			
0174h			
0175h			
0176h			
0177h			
0178h			
0179h			
017Ah			
017Bh			
017Ch			
017Dh			
017Eh			
017Fh			

X: Undefined

NOTE:

1. The blank regions are reserved. Do not access locations in these regions.

Table 4.7 SFR Information (7)(1)

Address	Register	Symbol	After reset
0180h			
0181h			
0182h			
0183h			
0184h			
0185h			
0186h			
0187h			
0188h			
0189h			
018Ah			
018Bh			
018Ch			
018Dh			
018Eh			
018Fh			
0190h			
0191h			
0192h			
0193h			
0194h			
0195h			
0196h			
0197h			
0198h			
0199h			
019Ah			
019Bh			
019Ch			
019Dh			
019Eh			
019Fh			
01A0h			
01A1h			
01A2h			
01A3h			
01A4h			
01A5h			
01A6h			
01A7h			
01A8h			
01A9h			
01AAh			
01ABh			
01ACh			
01ADh			
01AEh			
01AFh			
01B0h			
01B1h			
01B2h			
01B3h	Flash Memory Control Register 4	FMR4	01000000b
01B4h			
01B5h	Flash Memory Control Register1	FMR1	1000000Xb
01B6h			
01B7h	Flash Memory Control Register 0	FMR0	00000001b
01B8h			
01B9h			
01BAh			
01BBh			
01BCh			
01BDh			
01BEh			
01BFh			
FFFFh	Option Function Select Register	OFS	(Note 2)

X: Undefined

NOTES:

1. The blank regions are reserved. Do not access locations in these regions.
2. The OFS register cannot be changed by a program. Use a flash programmer to write to it.

5. Resets

The following resets are implemented: hardware reset, power-on reset, voltage monitor 0 reset, voltage monitor 1 reset, voltage monitor 2 reset, watchdog timer reset, and software reset.

Table 5.1 lists the Reset Names and Sources.

Table 5.1 Reset Names and Sources

Reset Name	Source
Hardware reset	Input voltage of $\overline{\text{RESET}}$ pin is held "L"
Power-on reset	VCC rises
Voltage monitor 0 reset	VCC falls (monitor voltage: Vdet0)
Voltage monitor 1 reset	VCC falls (monitor voltage: Vdet1)
Voltage monitor 2 reset	VCC falls (monitor voltage: Vdet2)
Watchdog timer reset	Underflow of watchdog timer
Software reset	Write 1 to PM03 bit in PM0 register

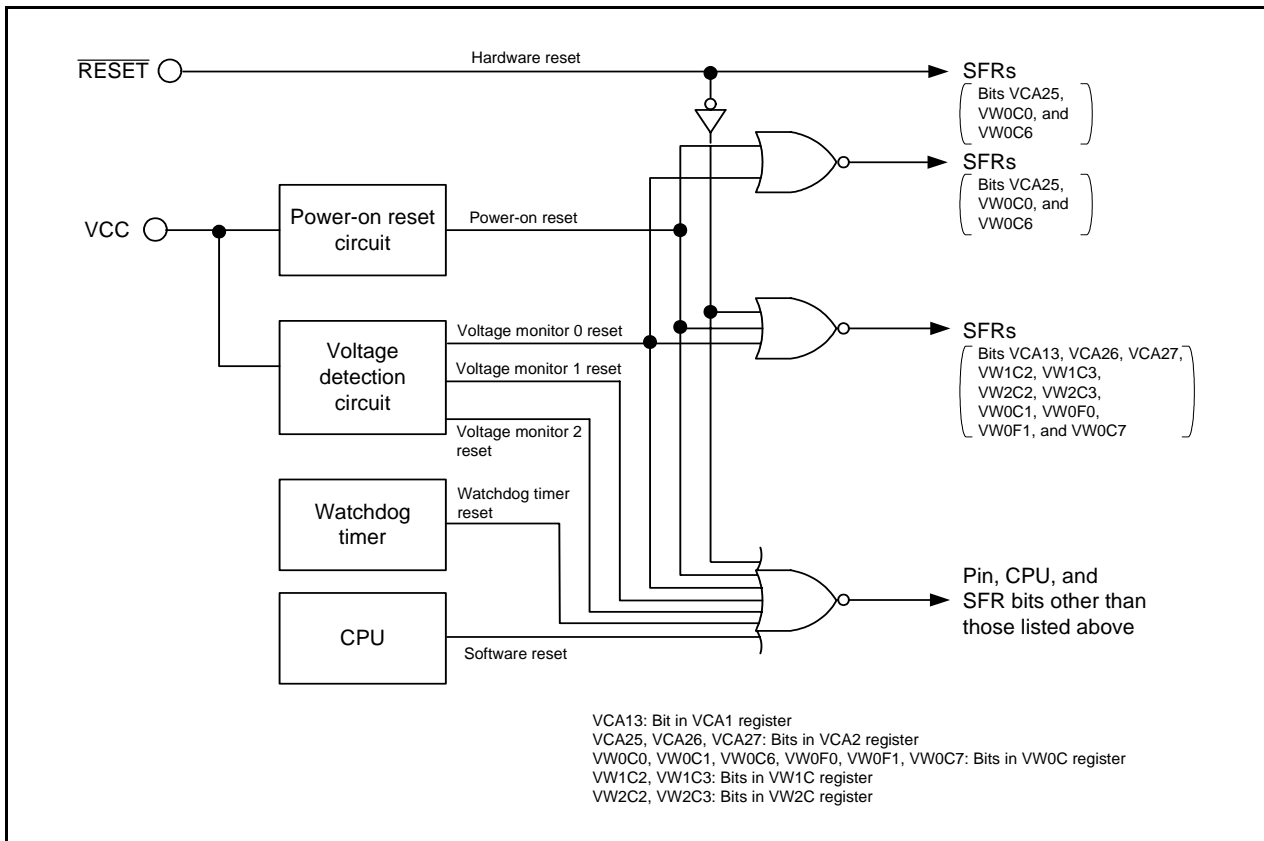

Figure 5.1 Block Diagram of Reset Circuit

Table 5.2 shows the Pin Functions while $\overline{\text{RESET}}$ Pin Level is “L”, Figure 5.2 shows the CPU Register Status after Reset, Figure 5.3 shows the Reset Sequence, and Figure 5.4 shows the OFS Register.

Table 5.2 Pin Functions while $\overline{\text{RESET}}$ Pin Level is “L”

Pin Name	Pin Functions
P0, P1, P2	Input port
P3_0, P3_1, P3_3 to P3_5, P3_7	Input port
P4_2 to P4_7	Input port
P6	Input port

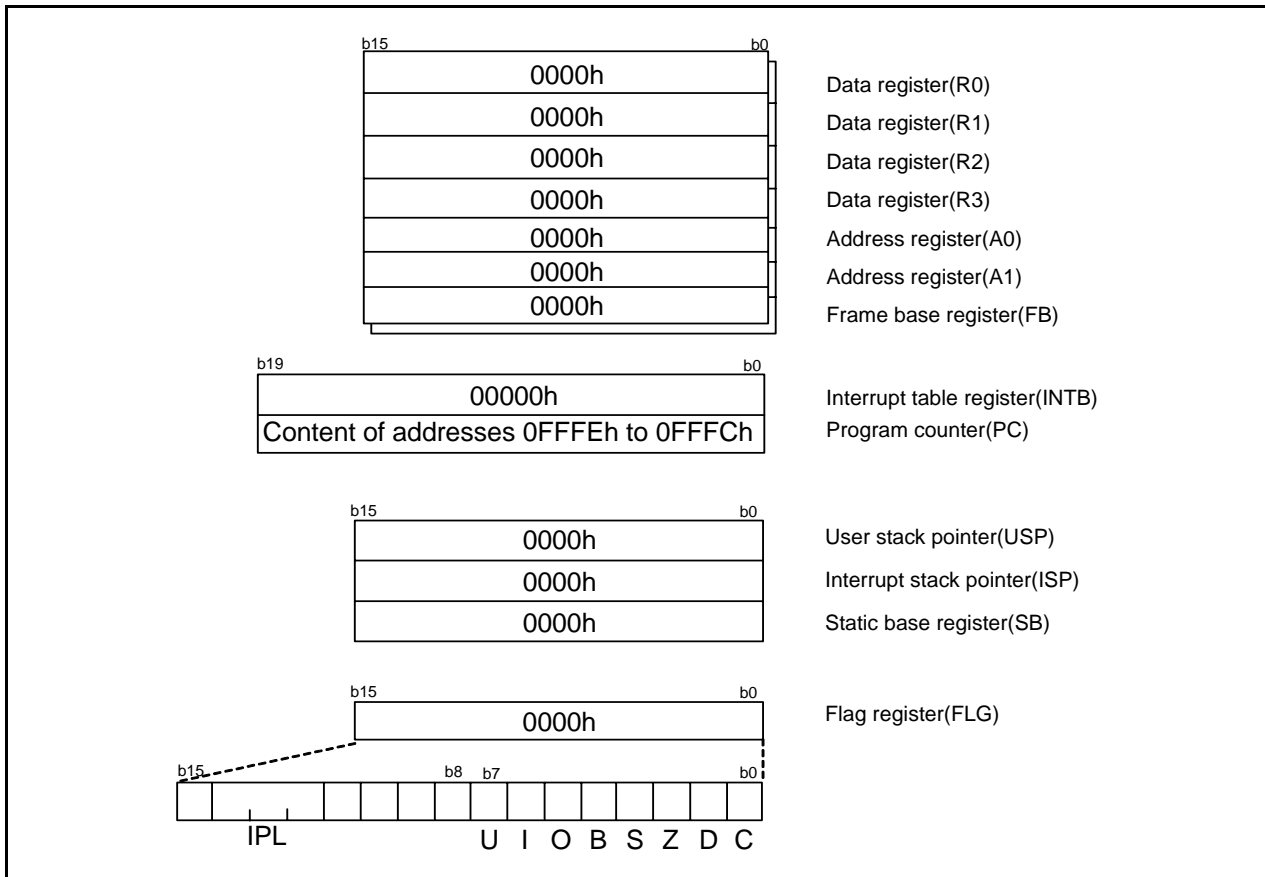

Figure 5.2 CPU Register Status after Reset

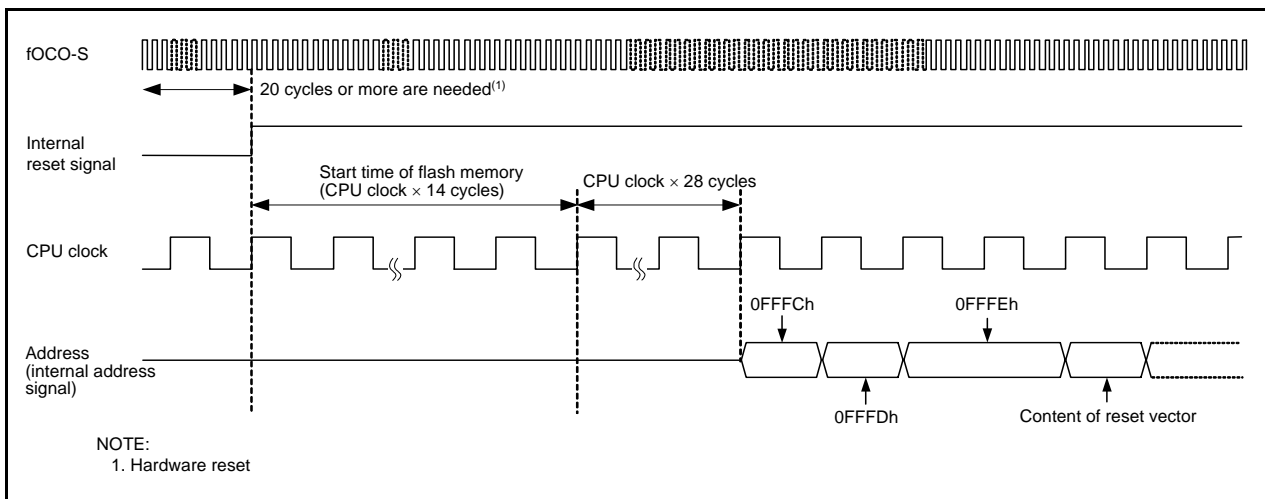

Figure 5.3 Reset Sequence

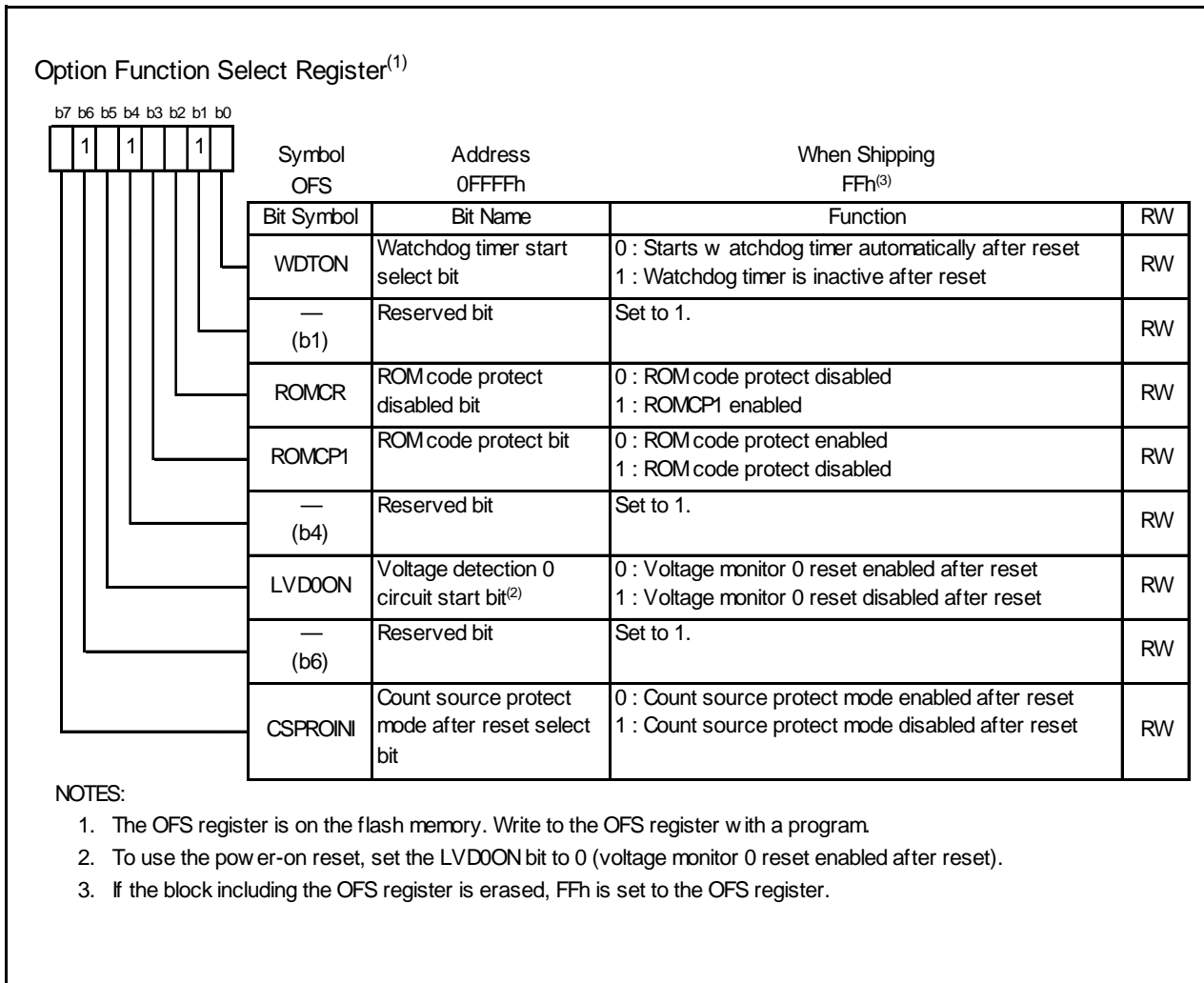

Figure 5.4 OFS Register

5.1 Hardware Reset

A reset is applied using the $\overline{\text{RESET}}$ pin. When an “L” signal is applied to the $\overline{\text{RESET}}$ pin while the supply voltage meets the recommended operating conditions, pins, CPU, and SFRs are all reset (refer to **Table 5.2 Pin Functions while RESET Pin Level is “L”**). When the input level applied to the $\overline{\text{RESET}}$ pin changes from “L” to “H”, a program is executed beginning with the address indicated by the reset vector. After reset, the low-speed on-chip oscillator clock divided by 8 is automatically selected as the CPU clock.

Refer to **4. Special Function Registers (SFRs)** for the state of the SFRs after reset.

The internal RAM is not reset. If the $\overline{\text{RESET}}$ pin is pulled “L” while writing to the internal RAM is in progress, the contents of internal RAM will be undefined.

Figure 5.5 shows an Example of Hardware Reset Circuit and Operation and Figure 5.6 shows an Example of Hardware Reset Circuit (Usage Example of External Supply Voltage Detection Circuit) and Operation.

5.1.1 When Power Supply is Stable

- (1) Apply “L” to the $\overline{\text{RESET}}$ pin.
- (2) Wait for $1/f_{\text{OCO-S}} \times 20$.
- (3) Apply “H” to the $\overline{\text{RESET}}$ pin.

5.1.2 Power On

- (1) Apply “L” to the $\overline{\text{RESET}}$ pin.
- (2) Let the supply voltage increase until it meets the recommended operating conditions.
- (3) Wait for $t_{\text{d(P-R)}}$ or more to allow the internal power supply to stabilize (refer to **20. Electrical Characteristics**).
- (4) Wait for $1/f_{\text{OCO-S}} \times 20$.
- (5) Apply “H” to the $\overline{\text{RESET}}$ pin.

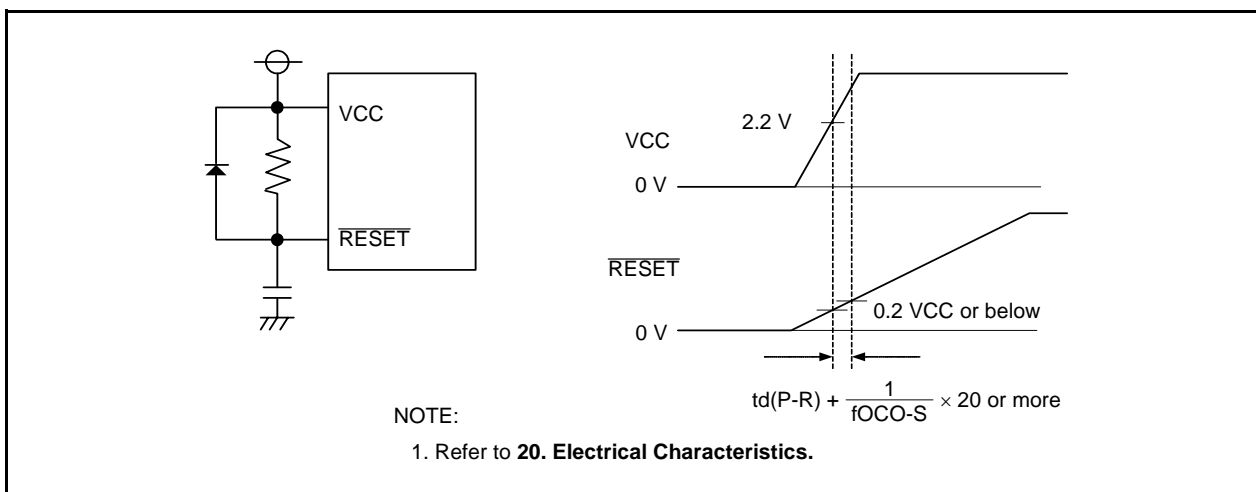

Figure 5.5 Example of Hardware Reset Circuit and Operation

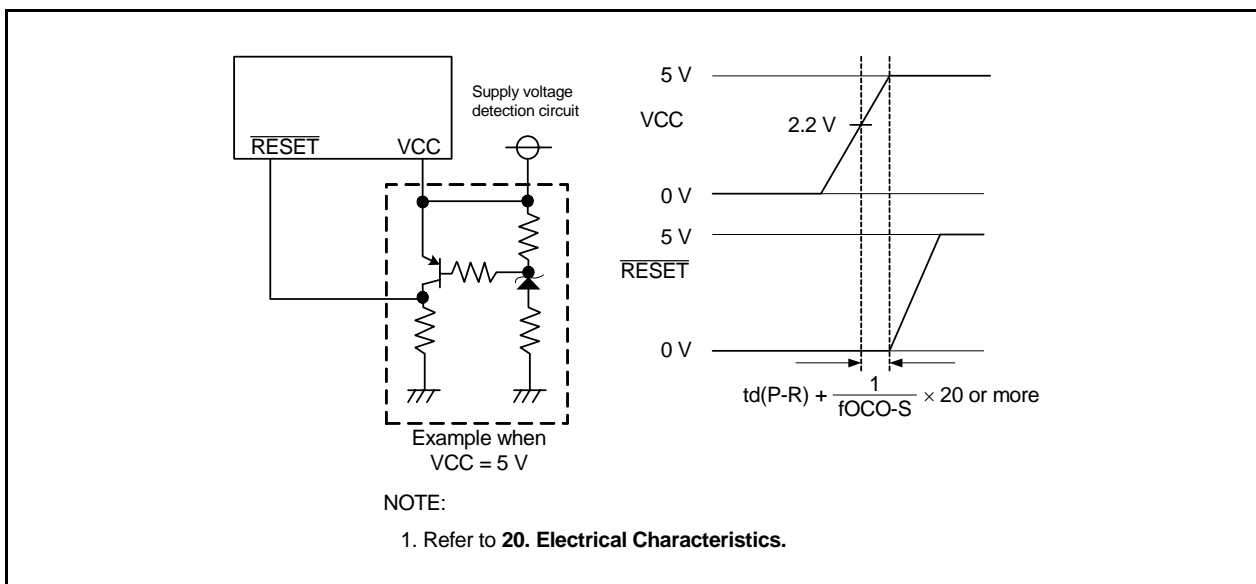

Figure 5.6 Example of Hardware Reset Circuit (Usage Example of External Supply Voltage Detection Circuit) and Operation

5.2 Power-On Reset Function

When the $\overline{\text{RESET}}$ pin is connected to the VCC pin via a pull-up resistor of about 5 k Ω , and the VCC pin voltage level rises, the power-on reset function is enabled and the MCU resets its pins, CPU, and SFR. When a capacitor is connected to the $\overline{\text{RESET}}$ pin, too, always keep the voltage to the $\overline{\text{RESET}}$ pin 0.8VCC or more.

When the input voltage to the VCC pin reaches the Vdet0 level or above, the low-speed on-chip oscillator clock starts counting. When the low-speed on-chip oscillator clock count reaches 32, the internal reset signal is held “H” and the MCU enters the reset sequence (refer to Figure 5.3). The low-speed on-chip oscillator clock divided by 8 is automatically selected as the CPU clock after reset.

Refer to **4. Special Function Registers (SFRs)** for the states of the SFR after power-on reset.

The voltage monitor 0 reset is enabled after power-on reset.

Figure 5.7 shows an Example of Power-On Reset Circuit and Operation.

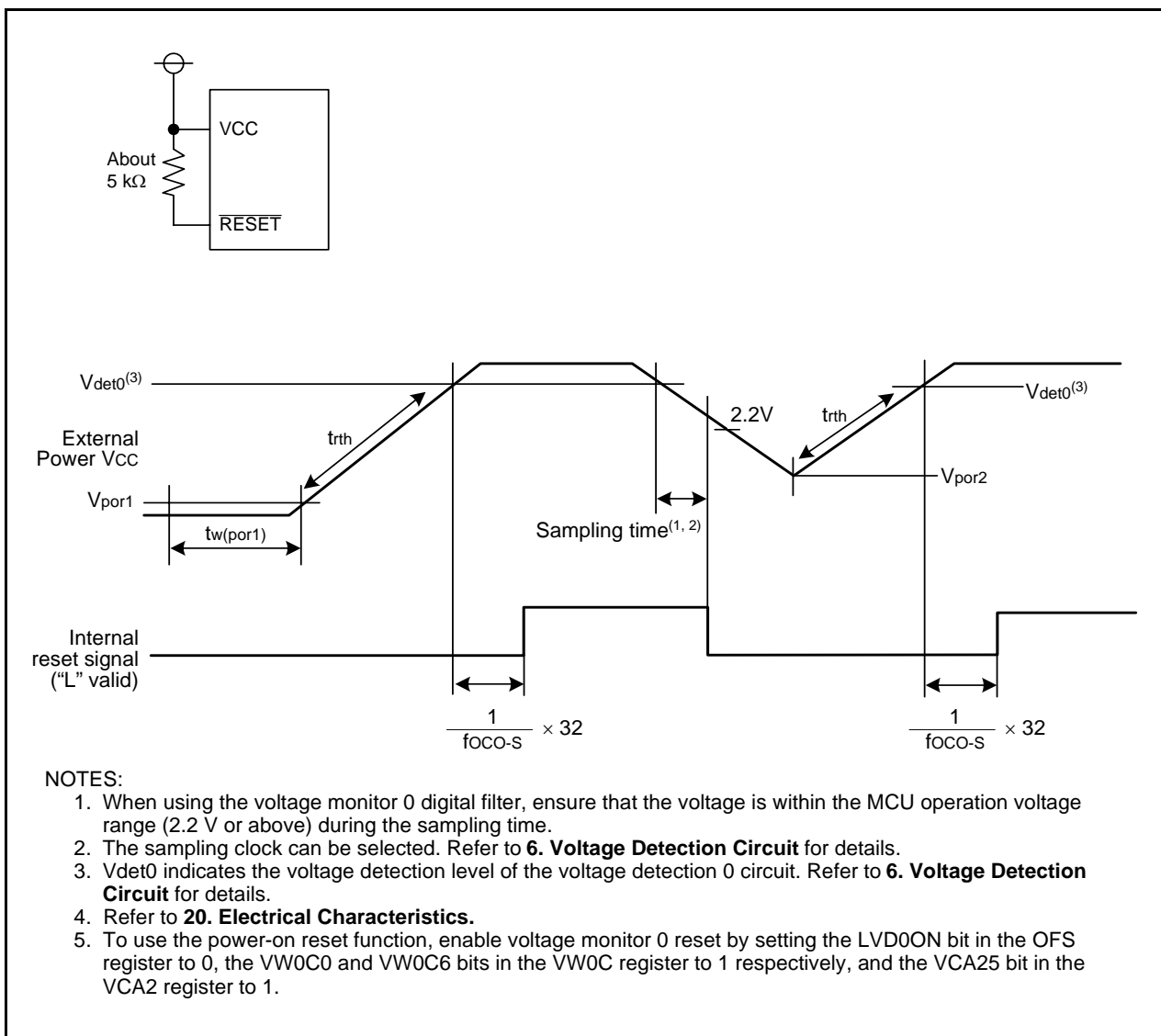

Figure 5.7 Example of Power-On Reset Circuit and Operation

5.3 Voltage Monitor 0 Reset

A reset is applied using the on-chip voltage detection 0 circuit. The voltage detection 0 circuit monitors the input voltage to the VCC pin. The voltage to monitor is Vdet0.

When the input voltage to the VCC pin reaches the Vdet0 level or below, the pins, CPU, and SFR are reset.

When the input voltage to the VCC pin reaches the Vdet0 level or above, the low-speed on-chip oscillator clock start counting. When the low-speed on-chip oscillator clock count reaches 32, the internal reset signal is held “H” and the MCU enters the reset sequence (refer to Figure 5.3). The low-speed on-chip oscillator clock divided by 8 is automatically selected as the CPU clock after reset.

The LVD0ON bit in the OFS register can be used to enable or disable voltage monitor 0 reset after a hardware reset. Setting the LVD0ON bit is only valid after a hardware reset.

To use the power-on reset function, enable voltage monitor 0 reset by setting the LVD0ON bit in the OFS register to 0, the VW0C0 and VW0C6 bits in the VW0C register to 1 respectively, and the VCA25 bit in the VCA2 register to 1.

The LVD0ON bit cannot be changed by a program. To set the LVD0ON bit, write 0 (voltage monitor 0 reset enabled after hardware reset) or 1 (voltage monitor 0 reset disabled after hardware reset) to bit 5 of address 0FFFFh using a flash programmer.

Refer to **Figure 5.4 OFS Register** for details of the OFS register.

Refer to **4. Special Function Registers (SFRs)** for the status of the SFR after voltage monitor 0 reset.

The internal RAM is not reset. When the input voltage to the VCC pin reaches the Vdet0 level or below while writing to the internal RAM is in progress, the contents of internal RAM are undefined.

Refer to **6. Voltage Detection Circuit** for details of voltage monitor 0 reset.

5.4 Voltage Monitor 1 Reset

A reset is applied using the on-chip voltage detection 1 circuit. The voltage detection 1 circuit monitors the input voltage to the VCC pin. The voltage to monitor is Vdet1.

When the input voltage to the VCC pin reaches the Vdet1 level or below, the pins, CPU, and SFR are reset and a program is executed beginning with the address indicated by the reset vector. After reset, the low-speed on-chip oscillator clock divided by 8 is automatically selected as the CPU clock.

The voltage monitor 1 does not reset some portions of the SFR. Refer to **4. Special Function Registers (SFRs)** for details.

The internal RAM is not reset. When the input voltage to the VCC pin reaches the Vdet1 level or below while writing to the internal RAM is in progress, the contents of internal RAM are undefined.

Refer to **6. Voltage Detection Circuit** for details of voltage monitor 1 reset.

5.5 Voltage Monitor 2 Reset

A reset is applied using the on-chip voltage detection 2 circuit. The voltage detection 2 circuit monitors the input voltage to the VCC pin. The voltage to monitor is Vdet2.

When the input voltage to the VCC pin reaches the Vdet2 level or below, the pins, CPU, and SFR are reset and the program beginning with the address indicated by the reset vector is executed. After reset, the low-speed on-chip oscillator clock divided by 8 is automatically selected as the CPU clock.

The voltage monitor 2 does not reset some SFRs. Refer to **4. Special Function Registers (SFRs)** for details.

The internal RAM is not reset. When the input voltage to the VCC pin reaches the Vdet2 level or below while writing to the internal RAM is in progress, the contents of internal RAM are undefined.

Refer to **6. Voltage Detection Circuit** for details of voltage monitor 2 reset.

5.6 Watchdog Timer Reset

When the PM12 bit in the PM1 register is set to 1 (reset when watchdog timer underflows), the MCU resets its pins, CPU, and SFR if the watchdog timer underflows. Then the program beginning with the address indicated by the reset vector is executed. After reset, the low-speed on-chip oscillator clock divided by 8 is automatically selected as the CPU clock.

The watchdog timer reset does not reset some SFRs. Refer to **4. Special Function Registers (SFRs)** for details. The internal RAM is not reset. When the watchdog timer underflows, the contents of internal RAM are undefined. Refer to **13. Watchdog Timer** for details of the watchdog timer.

5.7 Software Reset

When the PM03 bit in the PM0 register is set to 1 (MCU reset), the MCU resets its pins, CPU, and SFR. The program beginning with the address indicated by the reset vector is executed. After reset, the low-speed on-chip oscillator clock divided by 8 is automatically selected for the CPU clock.

The software reset does not reset some SFRs. Refer to **4. Special Function Registers (SFRs)** for details. The internal RAM is not reset.

6. Voltage Detection Circuit

The voltage detection circuit monitors the input voltage to the VCC pin. This circuit can be used to monitor the VCC input voltage by a program. Alternately, voltage monitor 0 reset, voltage monitor 1 interrupt, voltage monitor 1 reset, voltage monitor 2 interrupt, and voltage monitor 2 reset can also be used.

Table 6.1 lists the Specifications of Voltage Detection Circuit and Figures 6.1 to 6.4 show the Block Diagrams. Figures 6.5 to 6.8 show the Associated Registers.

Table 6.1 Specifications of Voltage Detection Circuit

	Item	Voltage Detection 0	Voltage Detection 1	Voltage Detection 2
VCC Monitor	Voltage to monitor	Vdet0	Vdet1	Vdet2
	Detection target	Whether passing through Vdet0 by rising or falling	Passing through Vdet1 by rising or falling	Passing through Vdet2 by rising or falling
	Monitor	None	VW1C3 bit in VW1C register Whether VCC is higher or lower than Vdet1	VCA13 bit in VCA1 register Whether VCC is higher or lower than Vdet2
Process When Voltage is Detected	Reset	Voltage monitor 0 reset Reset at Vdet0 > VCC; restart CPU operation at VCC > Vdet0	Voltage monitor 1 reset Reset at Vdet1 > VCC; restart CPU operation after a specified time	Voltage monitor 2 reset Reset at Vdet2 > VCC; restart CPU operation after a specified time
	Interrupt	None	Voltage monitor 1 interrupt Interrupt request at Vdet1 > VCC and VCC > Vdet1 when digital filter is enabled; interrupt request at Vdet1 > VCC or VCC > Vdet1 when digital filter is disabled	Voltage monitor 2 interrupt Interrupt request at Vdet2 > VCC and VCC > Vdet2 when digital filter is enabled; interrupt request at Vdet2 > VCC or VCC > Vdet2 when digital filter is disabled
Digital Filter	Switch enabled/disabled	Available	Available	Available
	Sampling time	(Divide-by-n of fOCO-S) × 4 n: 1, 2, 4, and 8	(Divide-by-n of fOCO-S) × 4 n: 1, 2, 4, and 8	(Divide-by-n of fOCO-S) × 4 n: 1, 2, 4, and 8

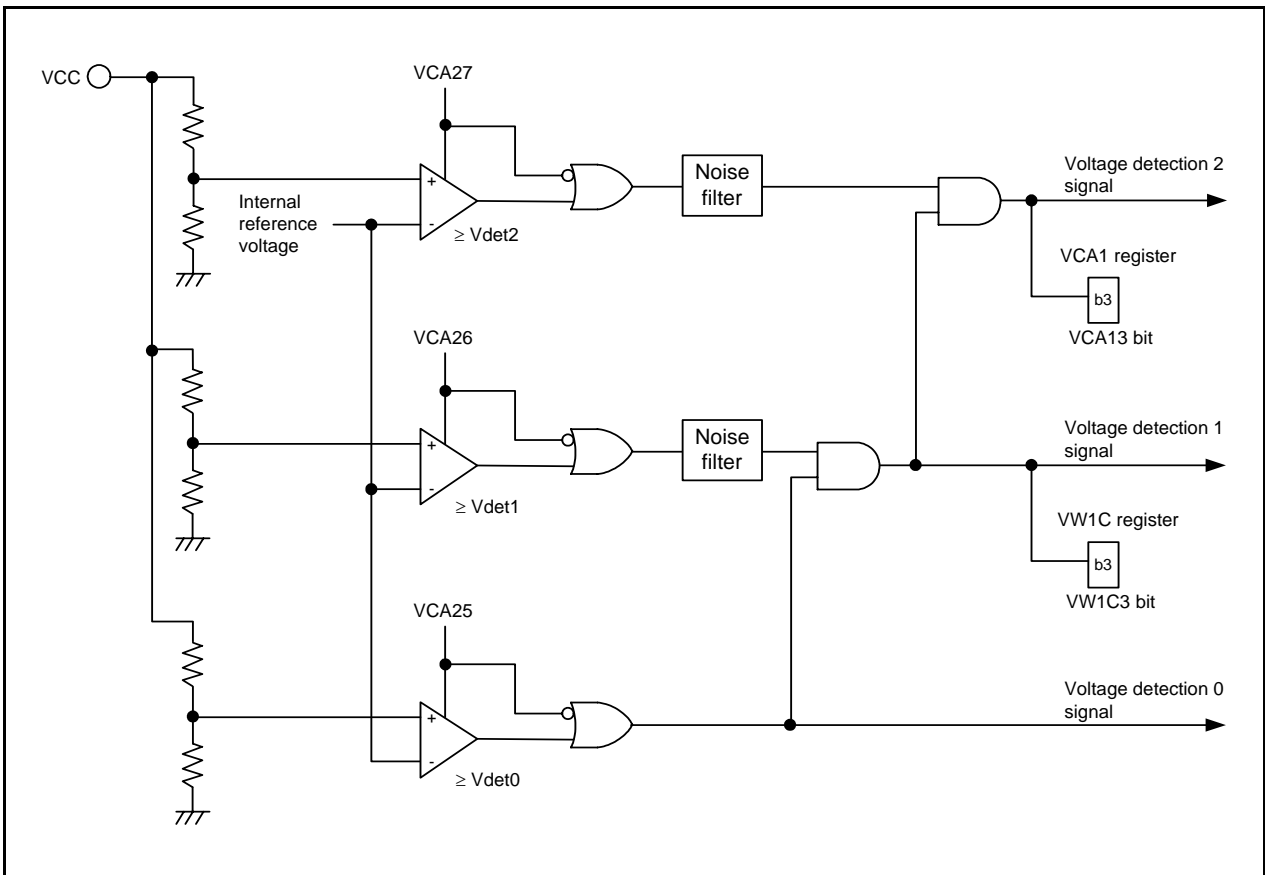

Figure 6.1 Block Diagram of Voltage Detection Circuit

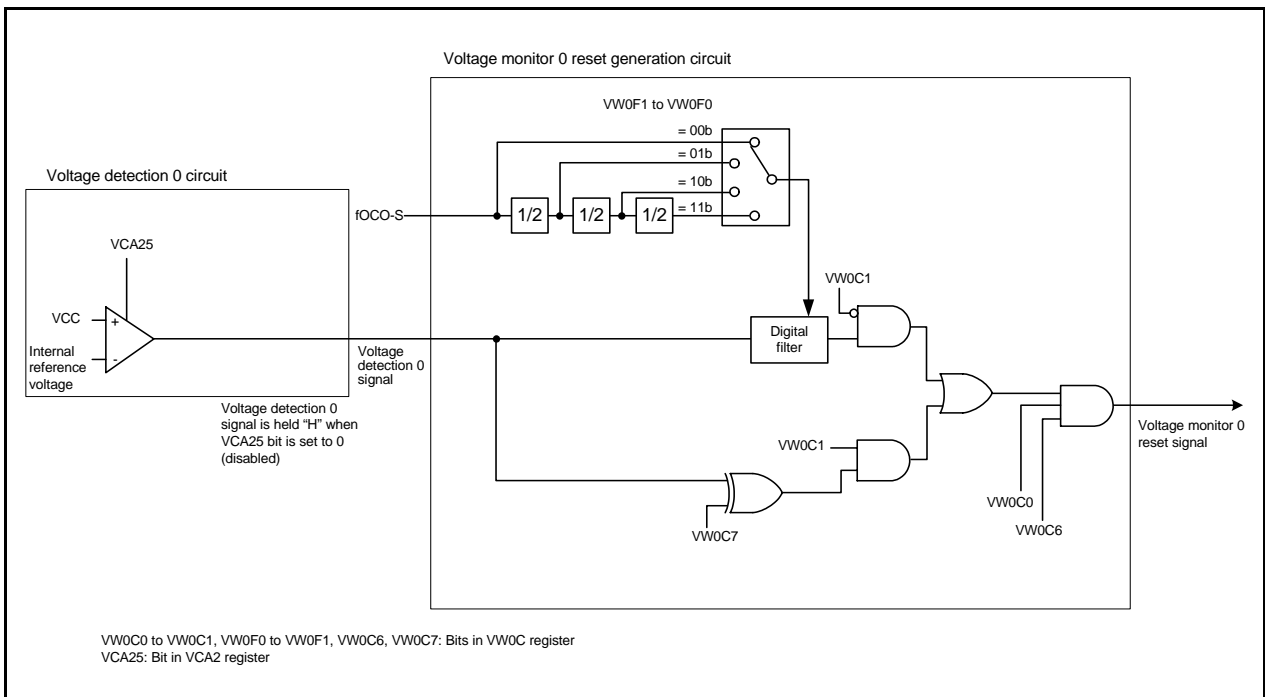

Figure 6.2 Block Diagram of Voltage Monitor 0 Reset Generation Circuit

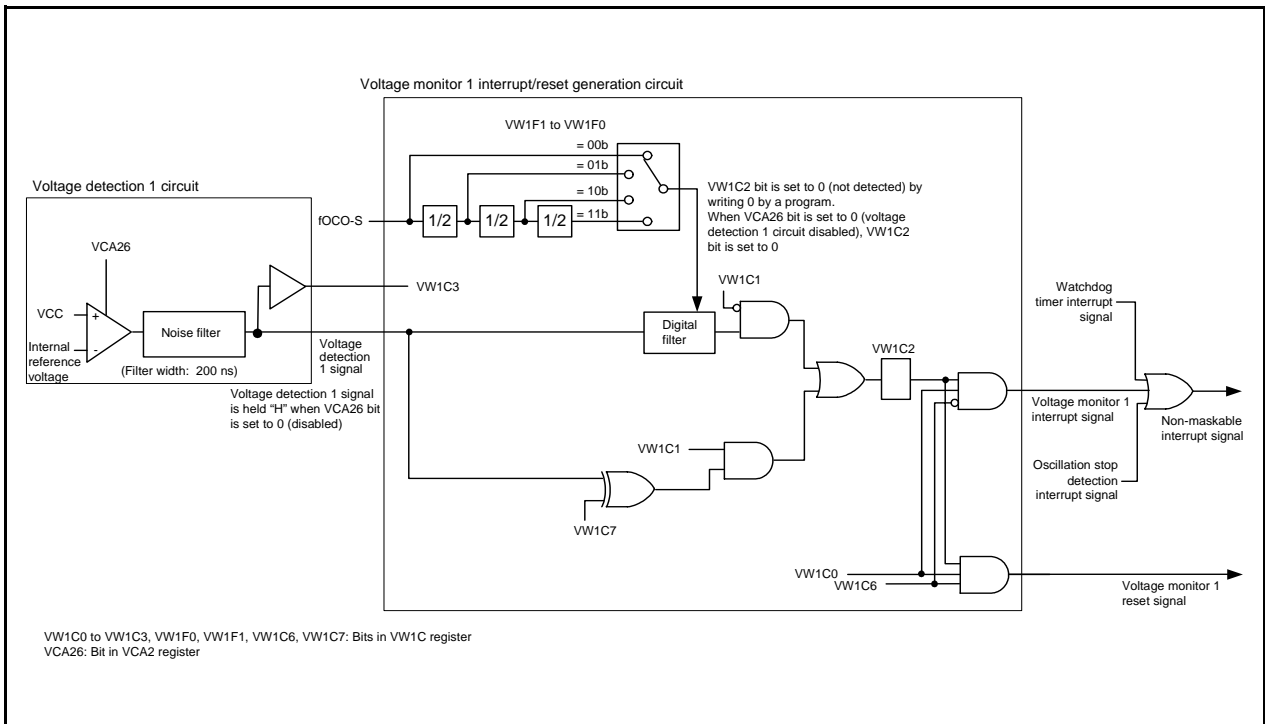

Figure 6.3 Block Diagram of Voltage Monitor 1 Interrupt/Reset Generation Circuit

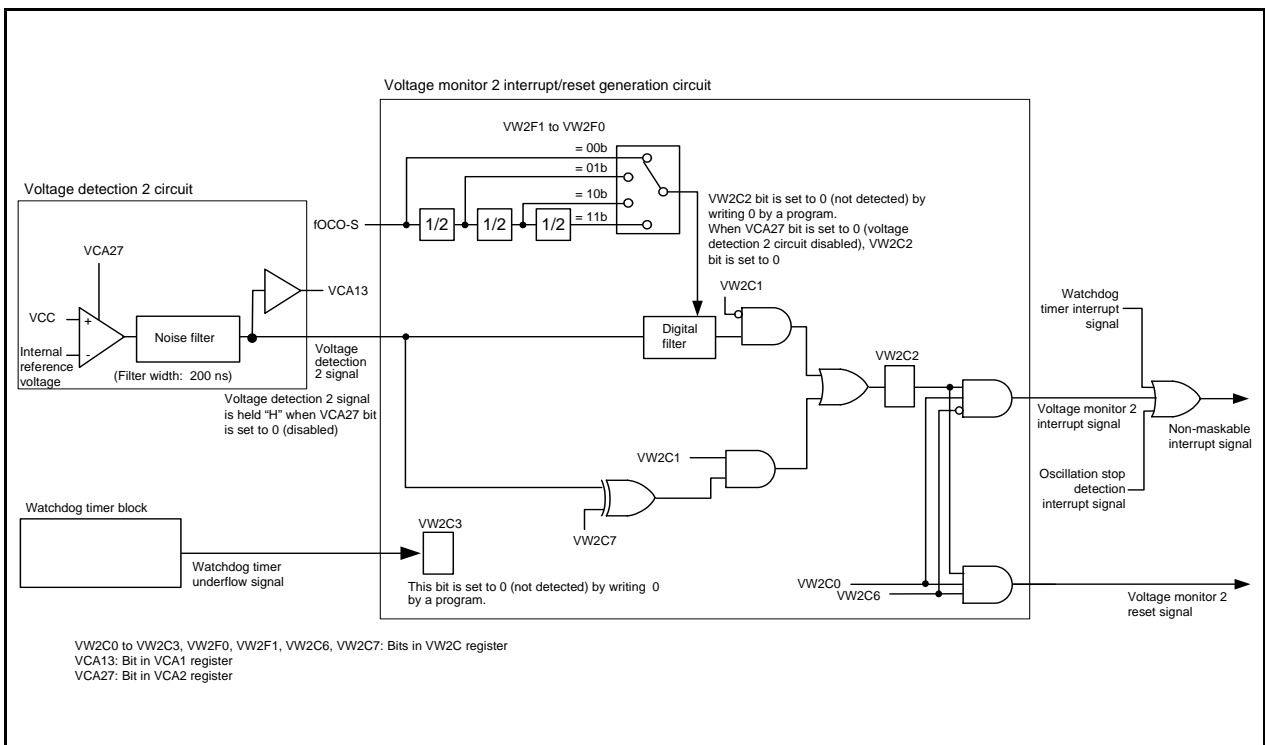

Figure 6.4 Block Diagram of Voltage Monitor 2 Interrupt/Reset Generation Circuit

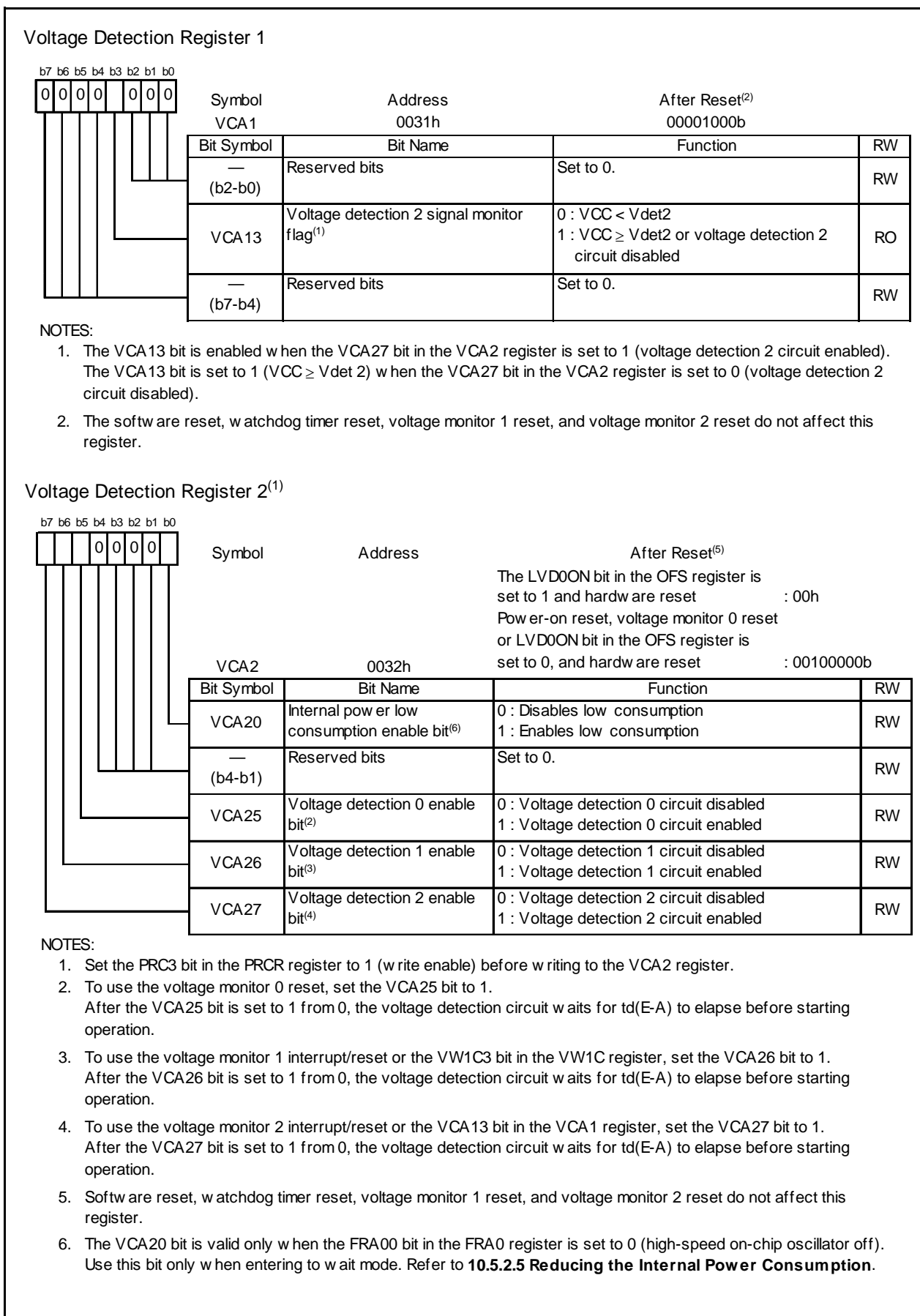

Figure 6.5 Registers VCA1 and VCA2

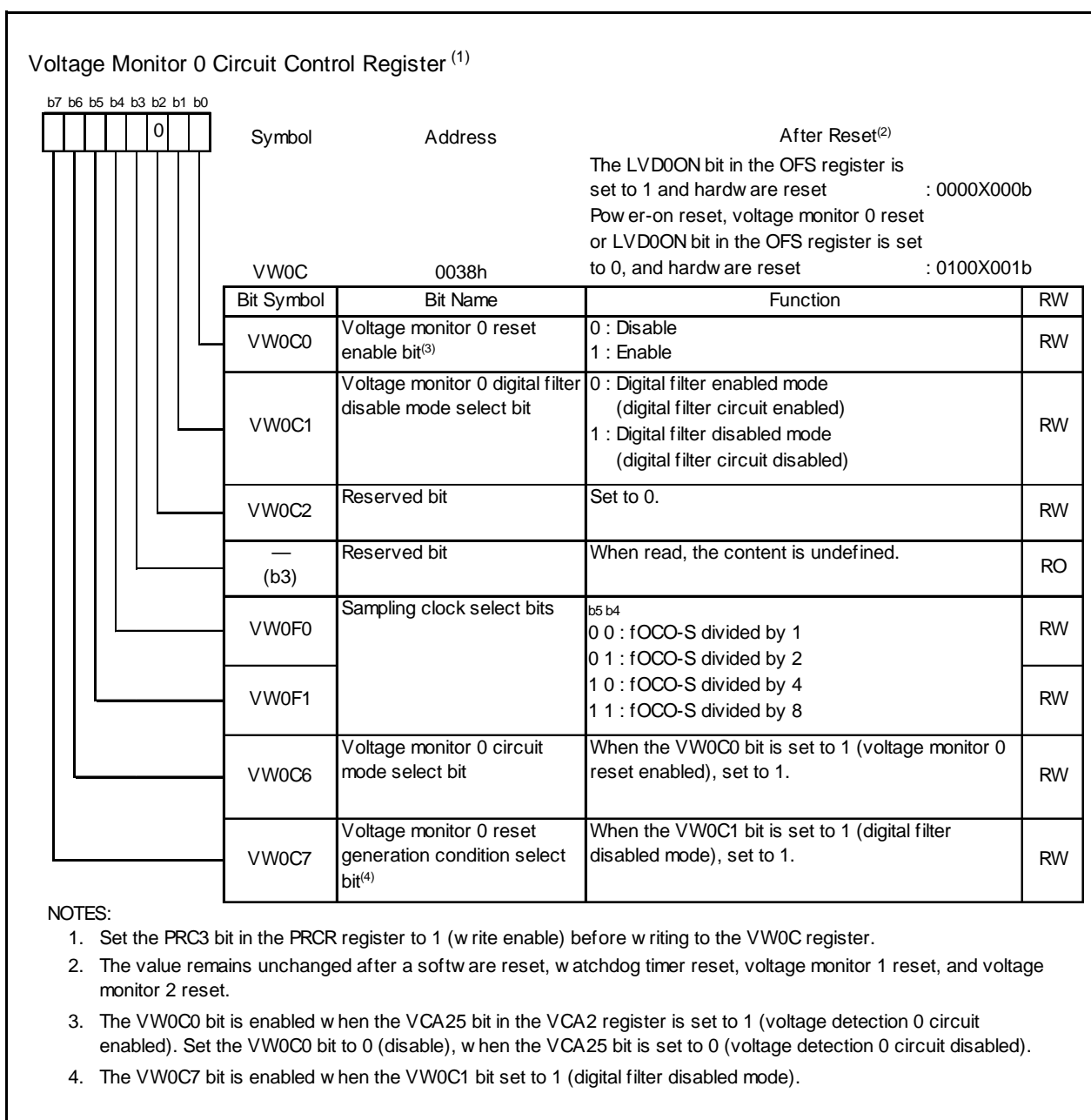

Figure 6.6 VW0C Register

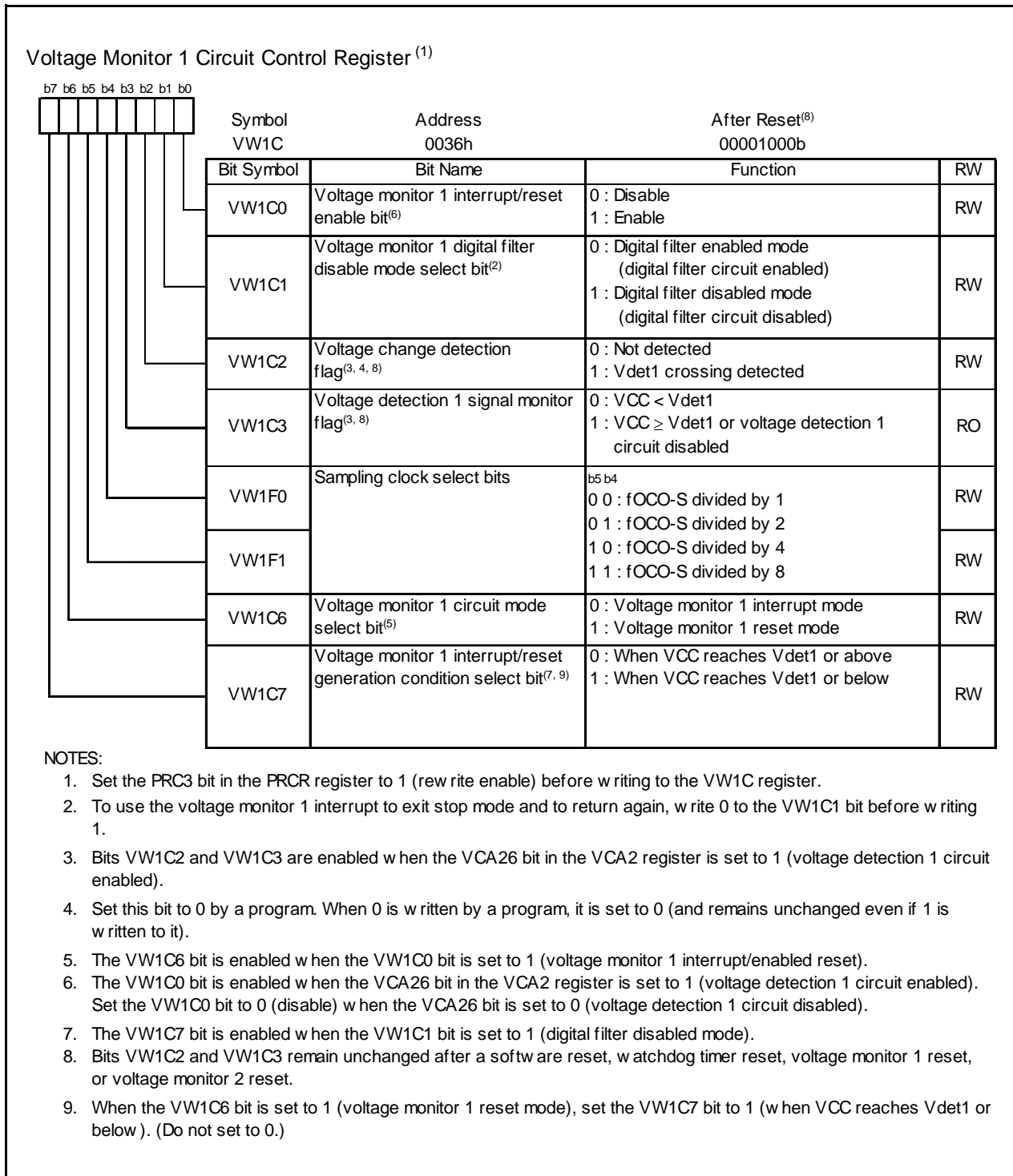

Figure 6.7 VW1C Register

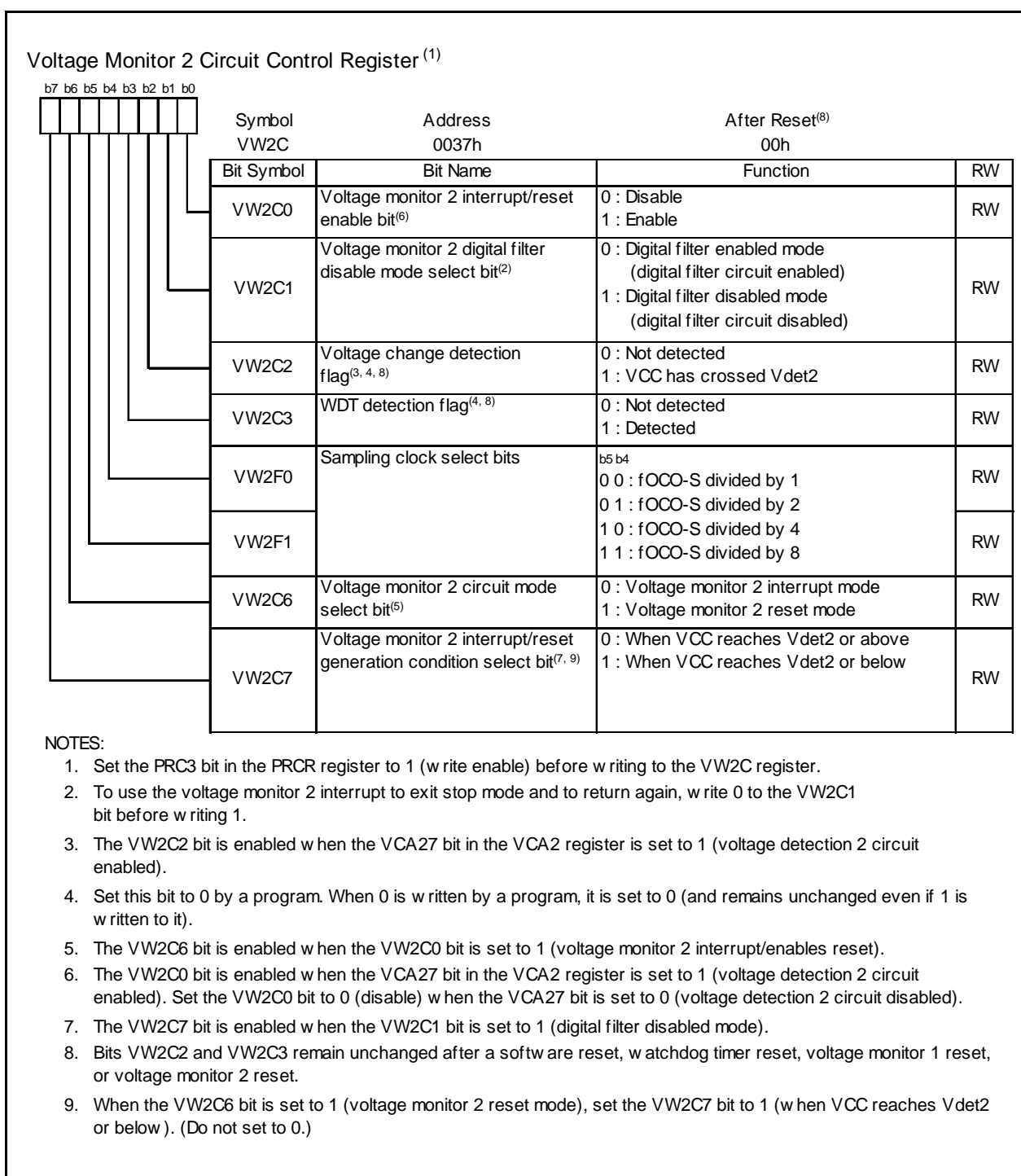

Figure 6.8 VW2C Register

6.1 VCC Input Voltage

6.1.1 Monitoring Vdet0

Vdet0 cannot be monitored.

6.1.2 Monitoring Vdet1

Set the VCA26 bit in the VCA2 register to 1 (voltage detection 1 circuit enabled). After td(E-A) has elapsed (refer to **20. Electrical Characteristics**), Vdet1 can be monitored by the VW1C3 bit in the VW1C register.

6.1.3 Monitoring Vdet2

Set the VCA27 bit in the VCA2 register to 1 (voltage detection 2 circuit enabled). After td(E-A) has elapsed (refer to **20. Electrical Characteristics**), Vdet2 can be monitored by the VCA13 bit in the VCA1 register.

6.2 Voltage Monitor 0 Reset

Table 6.2 lists the Procedure for Setting Bits Associated with Voltage Monitor Reset and Figure 6.9 shows an Example of Voltage Monitor 0 Reset Operation. To use the voltage monitor 0 reset to exit stop mode, set the VW0C1 bit in the VW0C register to 1 (digital filter disabled).

Table 6.2 Procedure for Setting Bits Associated with Voltage Monitor Reset

Step	When Using Digital Filter	When Not Using Digital Filter
1	Set the VCA25 bit in the VCA2 register to 1 (voltage detection 0 circuit enabled)	
2	Wait for $t_d(E-A)$	
3	Select the sampling clock of the digital filter by the VW0F0 to VW0F1 bits in the VW0C register	Set the VW0C7 bit in the VW0C register to 1
4(1)	Set the VW0C1 bit in the VW0C register to 0 (digital filter enabled)	Set the VW0C1 bit in the VW0C register to 1 (digital filter disabled)
5(1)	Set the VW0C6 bit in the VW0C register to 1 (voltage monitor 0 reset mode)	
6	Set the VW0C2 bit in the VW0C register to 0	
7	Set the CM14 bit in the CM1 register to 0 (low-speed on-chip oscillator on)	–
8	Wait for 4 cycles of the sampling clock of the digital filter	– (No wait time required)
9	Set the VW0C0 bit in the VW0C register to 1 (voltage monitor 0 reset enabled)	

NOTE:

- When the VW0C0 bit is set to 0, steps 3, 4, and 5 can be executed simultaneously (with 1 instruction).

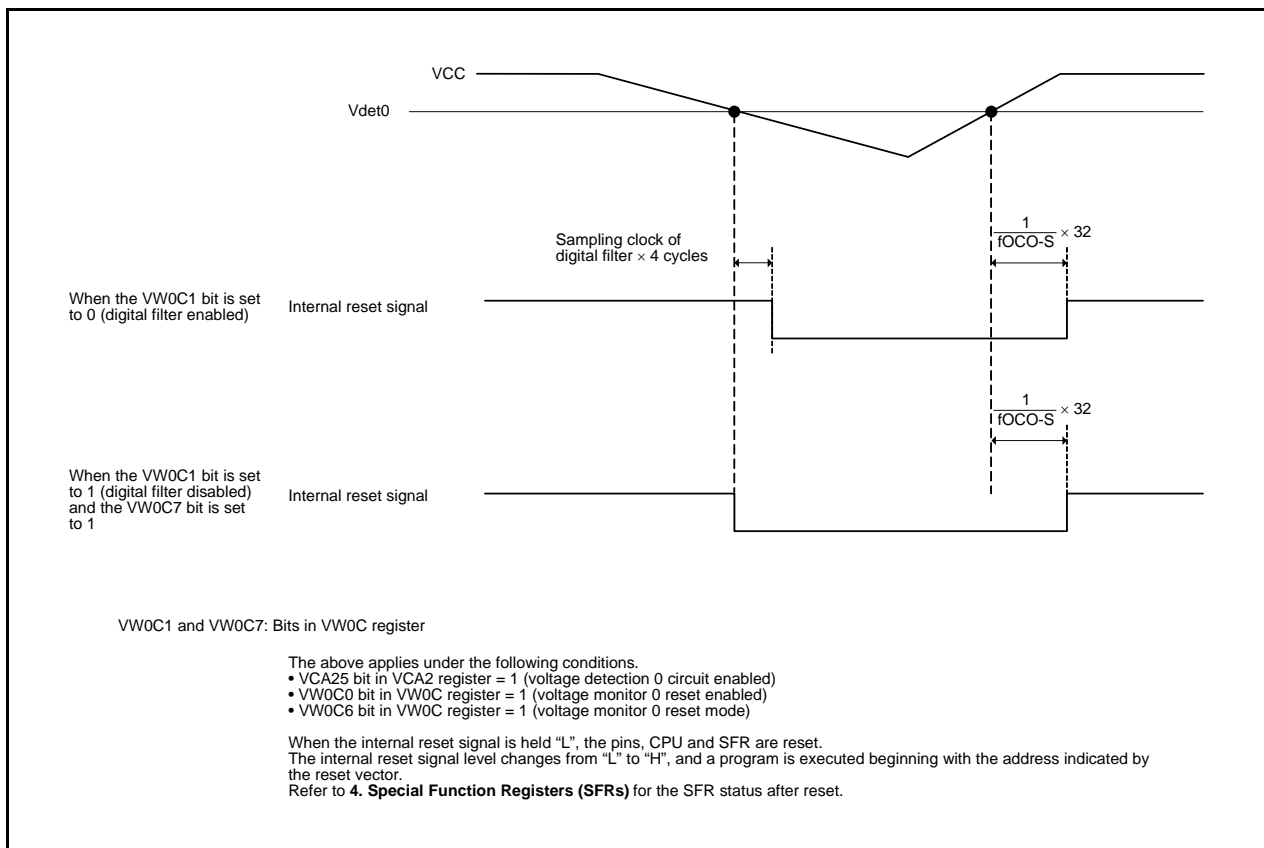

Figure 6.9 Example of Voltage Monitor 0 Reset Operation

6.3 Voltage Monitor 1 Interrupt and Voltage Monitor 1 Reset

Table 6.3 lists the Procedure for Setting Bits Associated with Voltage Monitor 1 Interrupt and Reset. Figure 6.10 shows an Example of Voltage Monitor 1 Interrupt and Voltage Monitor 1 Reset Operation. To use the voltage monitor 1 interrupt or voltage monitor 1 reset to exit stop mode, set the VW1C1 bit in the VW1C register to 1 (digital filter disabled).

Table 6.3 Procedure for Setting Bits Associated with Voltage Monitor 1 Interrupt and Reset

Step	When Using Digital Filter		When Not Using Digital Filter	
	Voltage Monitor 1 Interrupt	Voltage Monitor 1 Reset	Voltage Monitor 1 Interrupt	Voltage Monitor 1 Reset
1	Set the VCA26 bit in the VCA2 register to 1 (voltage detection 1 circuit enabled)			
2	Wait for $t_d(E-A)$			
3	Select the sampling clock of the digital filter by the VW1F0 to VW1F1 bits in the VW1C register		Select the timing of the interrupt and reset request by the VW1C7 bit in the VW1C register ⁽¹⁾	
4 ⁽²⁾	Set the VW1C1 bit in the VW1C register to 0 (digital filter enabled)		Set the VW1C1 bit in the VW1C register to 1 (digital filter disabled)	
5 ⁽²⁾	Set the VW1C6 bit in the VW1C register to 0 (voltage monitor 1 interrupt mode)	Set the VW1C6 bit in the VW1C register to 1 (voltage monitor 1 reset mode)	Set the VW1C6 bit in the VW1C register to 0 (voltage monitor 1 interrupt mode)	Set the VW1C6 bit in the VW1C register to 1 (voltage monitor 1 reset mode)
6	Set the VW1C2 bit in the VW1C register to 0 (passing of V_{det1} is not detected)			
7	Set the CM14 bit in the CM1 register to 0 (low-speed on-chip oscillator on)		-	
8	Wait for 4 cycles of the sampling clock of the digital filter		- (No wait time required)	
9	Set the VW1C0 bit in the VW1C register to 1 (voltage monitor 1 interrupt/reset enabled)			

NOTES:

1. Set the VW1C7 bit to 1 (when VCC reaches V_{det1} or below) for the voltage monitor 1 reset.
2. When the VW1C0 bit is set to 0, steps 3, 4, and 5 can be executed simultaneously (with 1 instruction).

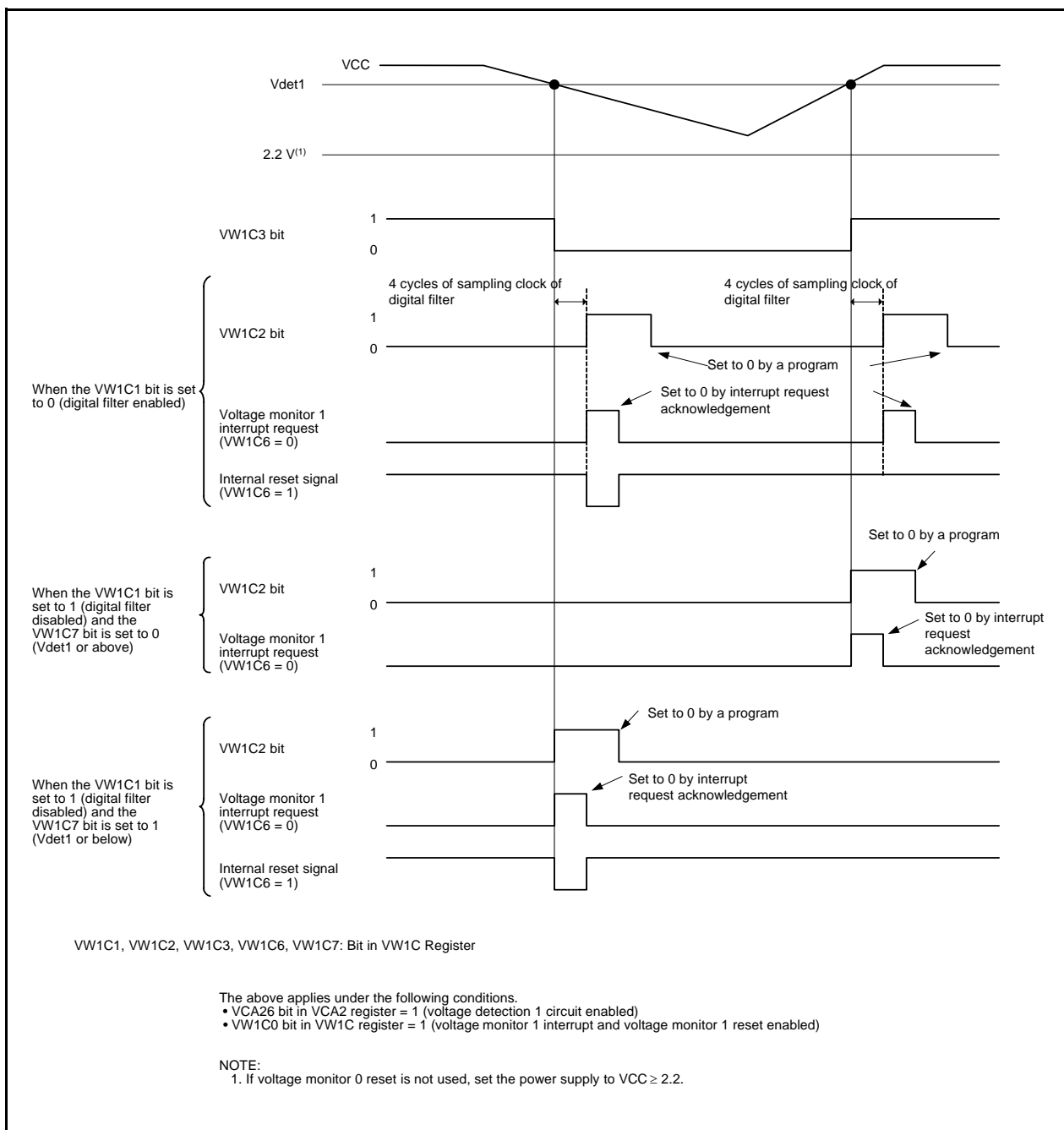

Figure 6.10 Example of Voltage Monitor 1 Interrupt and Voltage Monitor 1 Reset Operation

6.4 Voltage Monitor 2 Interrupt and Voltage Monitor 2 Reset

Table 6.4 lists the Procedure for Setting Bits Associated with Voltage Monitor 2 Interrupt and Reset. Figure 6.11 shows an Example of Voltage Monitor 2 Interrupt and Voltage Monitor 2 Reset Operation. To use the voltage monitor 2 interrupt or voltage monitor 2 reset to exit stop mode, set the VW2C1 bit in the VW2C register to 1 (digital filter disabled).

Table 6.4 Procedure for Setting Bits Associated with Voltage Monitor 2 Interrupt and Reset

Step	When Using Digital Filter		When Not Using Digital Filter	
	Voltage Monitor 2 Interrupt	Voltage Monitor 2 Reset	Voltage Monitor 2 Interrupt	Voltage Monitor 2 Reset
1	Set the VCA27 bit in the VCA2 register to 1 (voltage detection 2 circuit enabled)			
2	Wait for td(E-A)			
3	Select the sampling clock of the digital filter by the VW2F0 to VW2F1 bits in the VW2C register		Select the timing of the interrupt and reset request by the VW2C7 bit in the VW2C register ⁽¹⁾	
4	Set the VW2C1 bit in the VW2C register to 0 (digital filter enabled)		Set the VW2C1 bit in the VW2C register to 1 (digital filter disabled)	
5 ⁽²⁾	Set the VW2C6 bit in the VW2C register to 0 (voltage monitor 2 interrupt mode)	Set the VW2C6 bit in the VW2C register to 1 (voltage monitor 2 reset mode)	Set the VW2C6 bit in the VW2C register to 0 (voltage monitor 2 interrupt mode)	Set the VW2C6 bit in the VW2C register to 1 (voltage monitor 2 reset mode)
6	Set the VW2C2 bit in the VW2C register to 0 (passing of Vdet2 is not detected)			
7	Set the CM14 bit in the CM1 register to 0 (low-speed on-chip oscillator on)		-	
8	Wait for 4 cycles of the sampling clock of the digital filter		- (No wait time required)	
9	Set the VW2C0 bit in the VW2C register to 1 (voltage monitor 2 interrupt/reset enabled)			

NOTES:

1. Set the VW2C7 bit to 1 (when VCC reaches Vdet2 or below) for the voltage monitor 2 reset.
2. When the VW2C0 bit is set to 0, steps 3, 4, and 5 can be executed simultaneously (with 1 instruction).

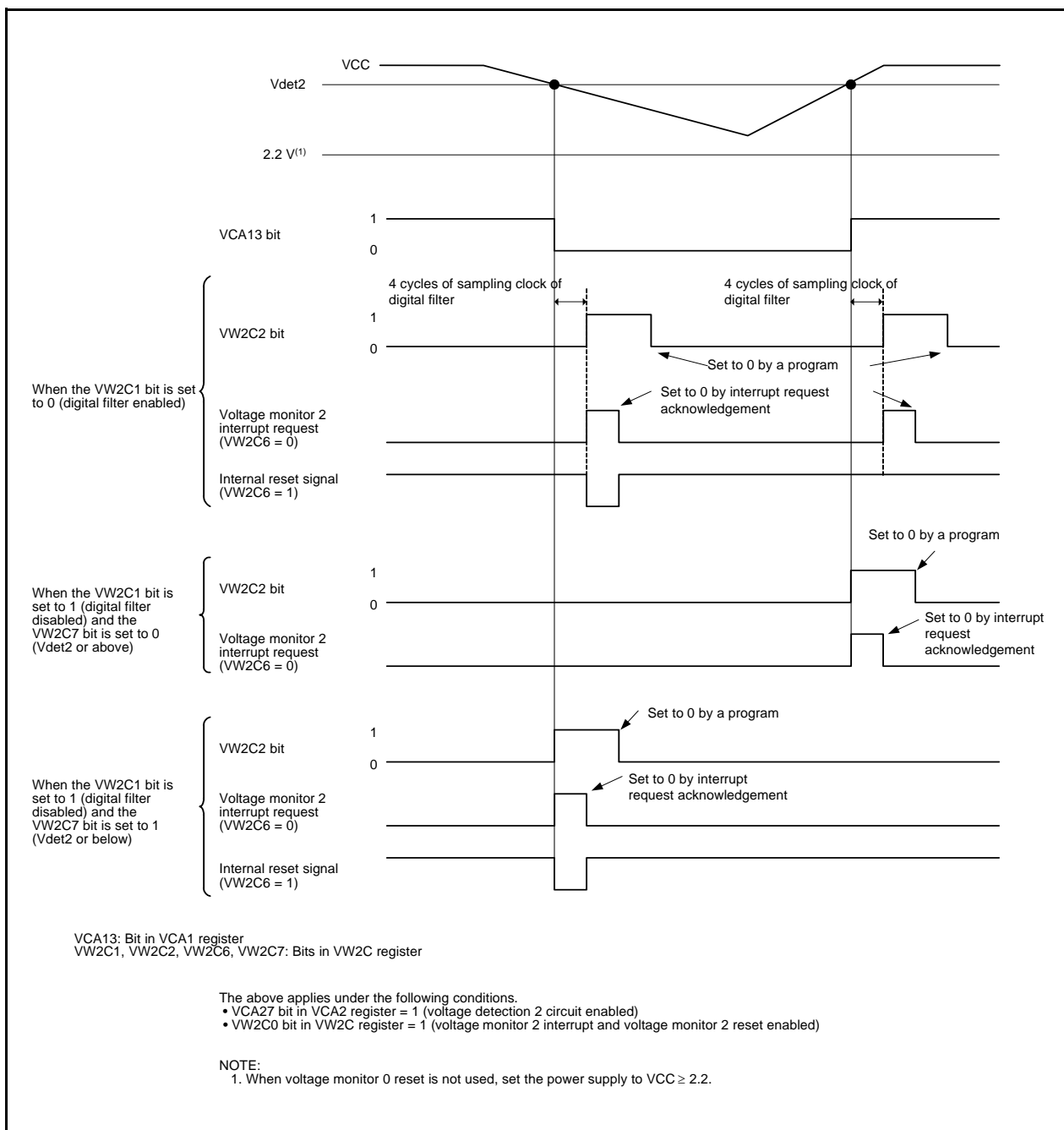

Figure 6.11 Example of Voltage Monitor 2 Interrupt and Voltage Monitor 2 Reset Operation

7. Programmable I/O Ports

There are 41 programmable Input/Output ports (I/O ports) P0 to P2, P3_0, P3_1, P3_3 to P3_5, P3_7, P4_3 to P4_5, and P6. Also, P4_6 and P4_7 can be used as input-only ports if the XIN clock oscillation circuit is not used, and the P4_2 can be used as an input-only port if the A/D converter is not used.

Table 7.1 lists an Overview of Programmable I/O Ports.

Table 7.1 Overview of Programmable I/O Ports

Ports	I/O	Type of Output	I/O Setting	Internal Pull-Up Resistor
P0 to P2, P6	I/O	CMOS3 State	Set per bit	Set every 4 bits ⁽¹⁾
P3_0, P3_1, P3_3 to P3_4, P3_5, P3_7	I/O	CMOS3 State	Set per bit	Set every 3 bits ⁽¹⁾
P4_3	I/O	CMOS3 State	Set per bit	Set every bit ⁽¹⁾
P4_4, P4_5	I/O	CMOS3 State	Set per bit	Set every 2 bits ⁽¹⁾
P4_2 ⁽²⁾ P4_6, P4_7 ⁽³⁾	I	(No output function)	None	None

NOTES:

1. In input mode, whether an internal pull-up resistor is connected or not can be selected by registers PUR0 and PUR1.
2. When the A/D converter is not used, this port can be used as the input-only port.
3. When the XIN clock oscillation circuit is not used, these ports can be used as the input-only ports.

7.1 Functions of Programmable I/O Ports

The PDi_j (j = 0 to 7) bit in the PDi (i = 0 to 4, 6) register controls I/O of the ports P0 to P2, P3_0, P3_1, P3_3 to P3_5, P3_7, P4_3 to P4_5, and P6. The Pi register consists of a port latch to hold output data and a circuit to read pin states.

Figures 7.1 to 7.7 show the Configurations of Programmable I/O Ports. Table 7.2 lists the Functions of Programmable I/O Ports. Also, Figure 7.9 shows the PDi (i = 0 to 4 and 6) Registers. Figure 7.10 shows the Pi (i = 0 to 4 and 6) Registers, Figure 7.11 shows Registers PUR0 and PUR1, and Figure 7.12 shows the PMR Register.

Table 7.2 Functions of Programmable I/O Ports

Operation When Accessing Pi Register	Value of PDi_j Bit in PDi Register ⁽¹⁾	
	When PDi_j Bit is Set to 0 (Input Mode)	When PDi_j Bit is Set to 1 (Output Mode)
Reading	Read pin input level	Read the port latch
Writing	Write to the port latch	Write to the port latch. The value written to the port latch is output from the pin.

i = 0 to 4, 6 j = 0 to 7

NOTE:

1. Nothing is assigned to bits PD3_2, PD3_6, PD4_0 to PD4_2, PD4_6, and PD4_7.

7.2 Effect on Peripheral Functions

Programmable I/O ports function as I/O ports for peripheral functions (Refer to **Table 1.6 Pin Name Information by Pin Number**).

Table 7.3 lists the Setting of PDi_j Bit when Functioning as I/O Ports for Peripheral Functions (i = 0 to 4, 6 j = 0 to 7). Refer to the description of each function for information on how to set peripheral functions.

Table 7.3 Setting of PDi_j Bit when Functioning as I/O Ports for Peripheral Functions (i = 0 to 4, 6 j = 0 to 7)

I/O of Peripheral Functions	PDi_j Bit Settings for Shared Pin Functions
Input	Set this bit to 0 (input mode).
Output	This bit can be set to either 0 or 1 (output regardless of the port setting)

7.3 Pins Other than Programmable I/O Ports

Figure 7.8 shows the Configuration of I/O Pins.

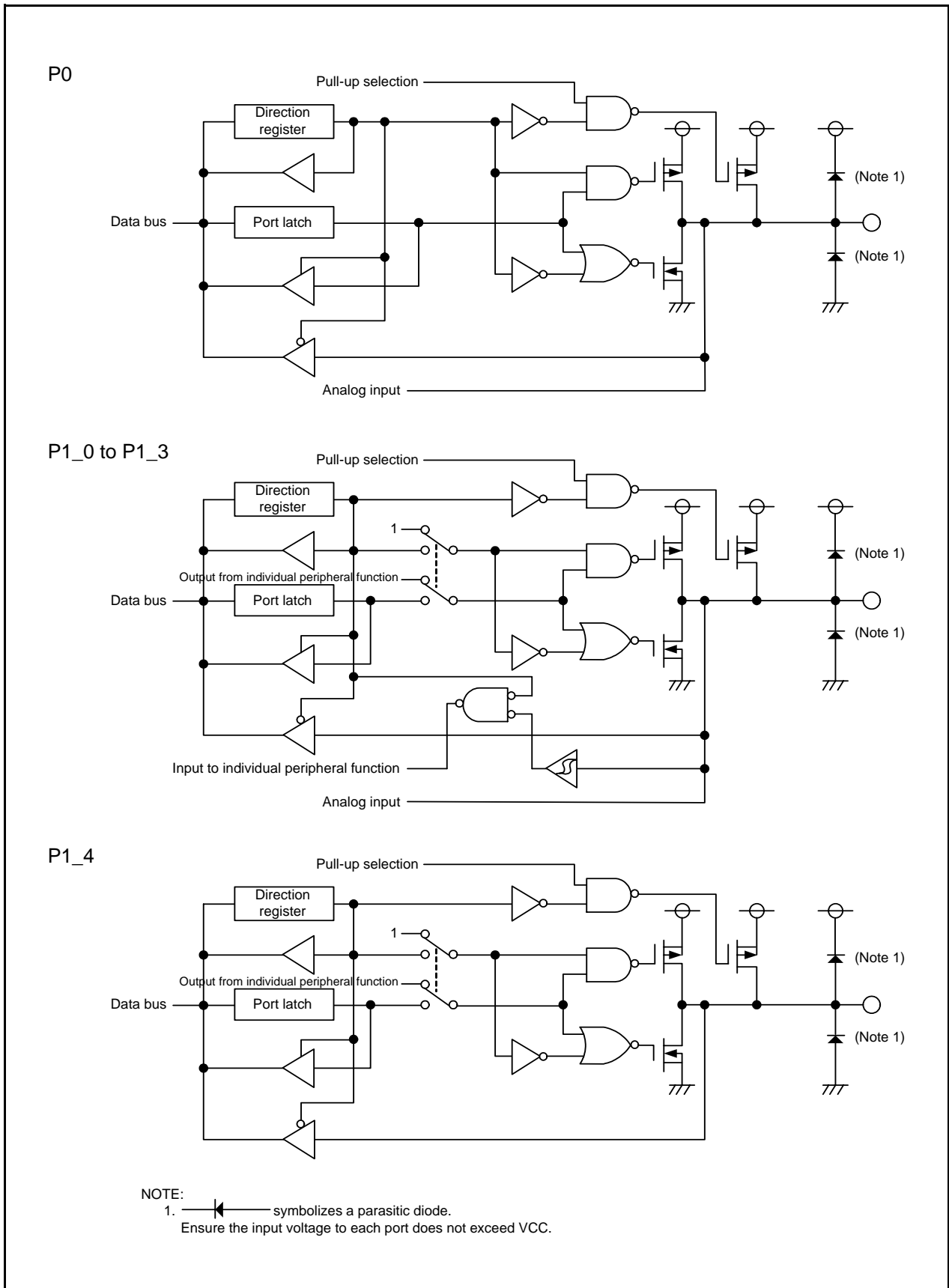

Figure 7.1 Configuration of Programmable I/O Ports (1)

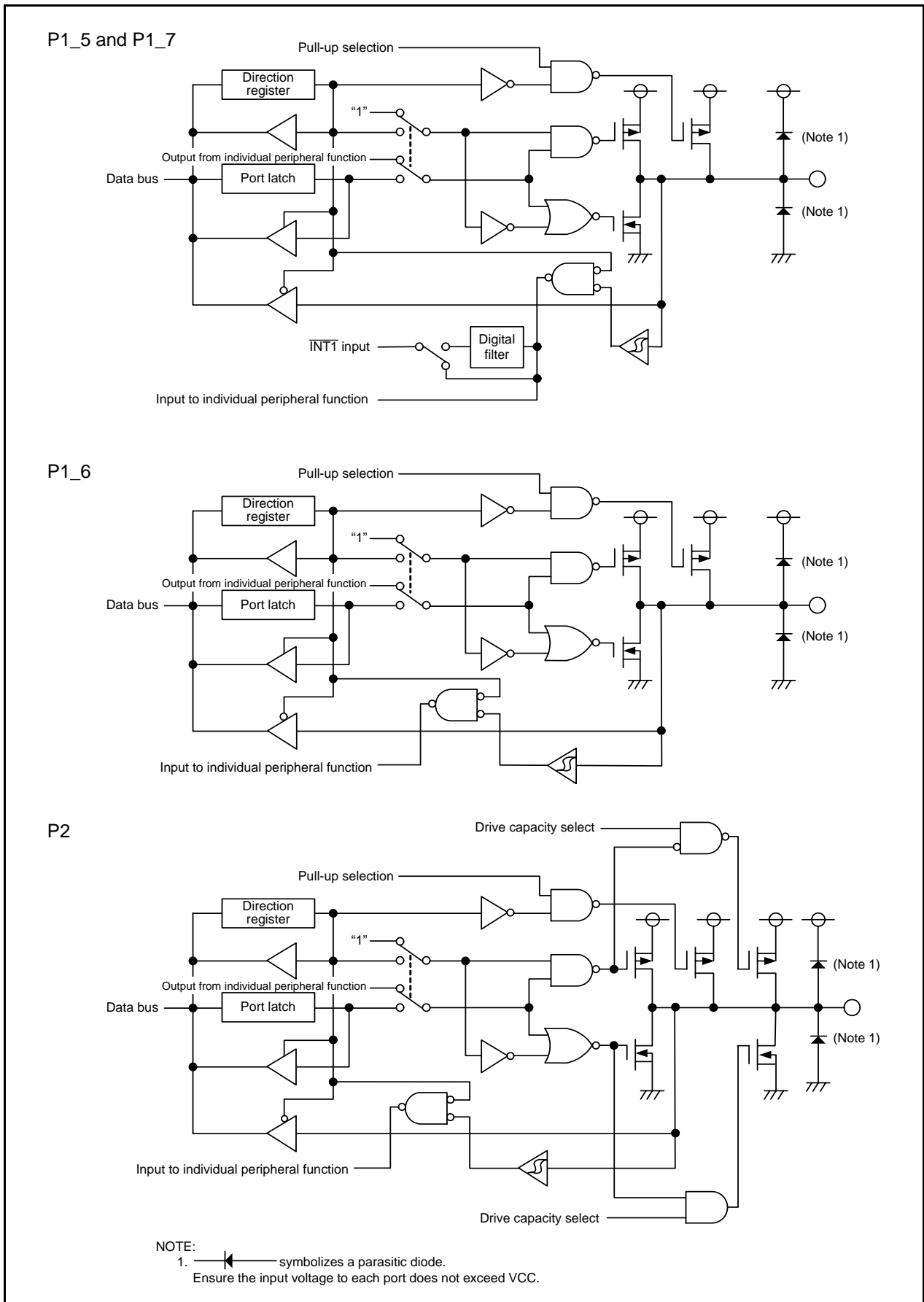

Figure 7.2 Configuration of Programmable I/O Ports (2)

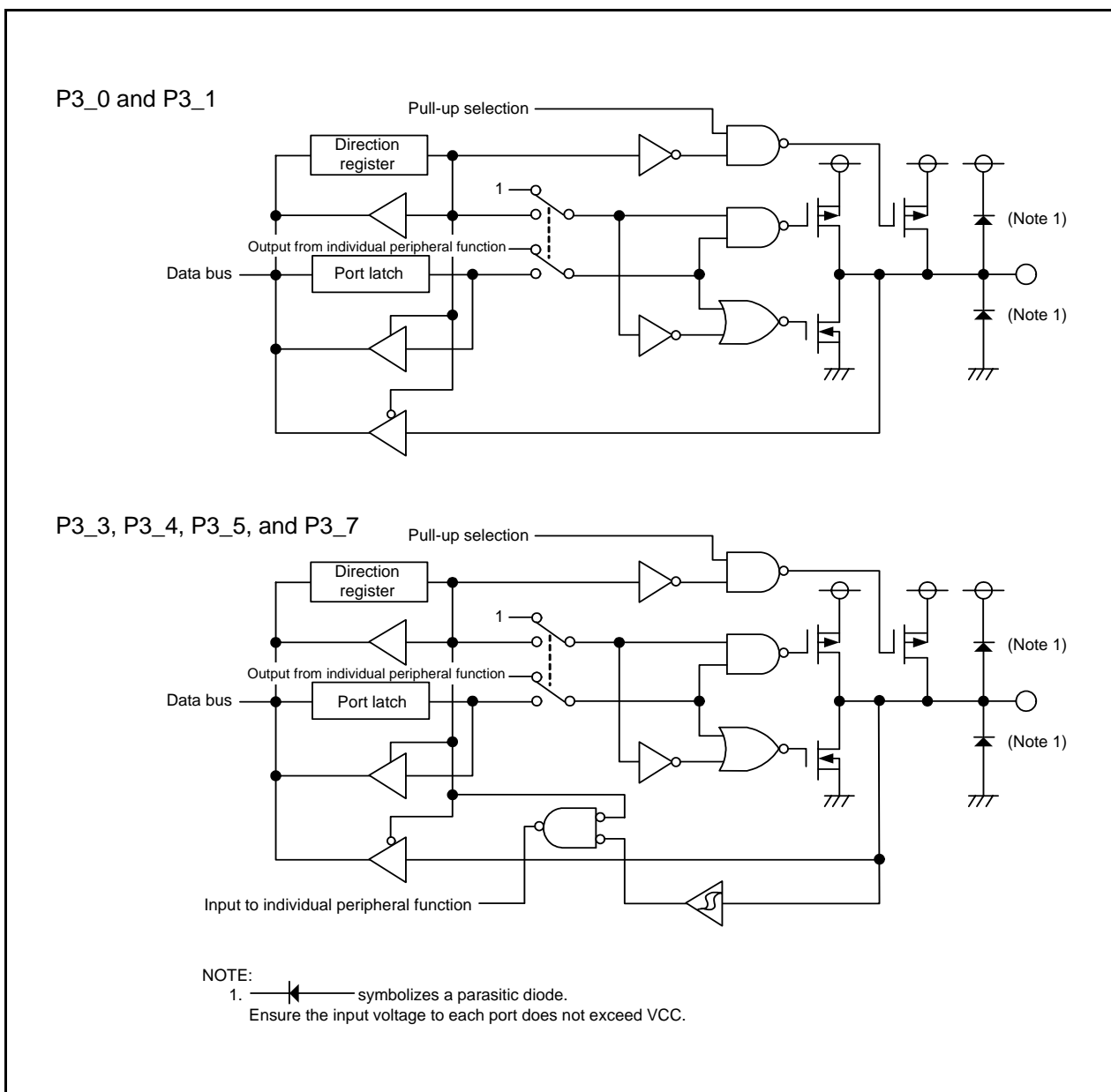

Figure 7.3 Configuration of Programmable I/O Ports (3)

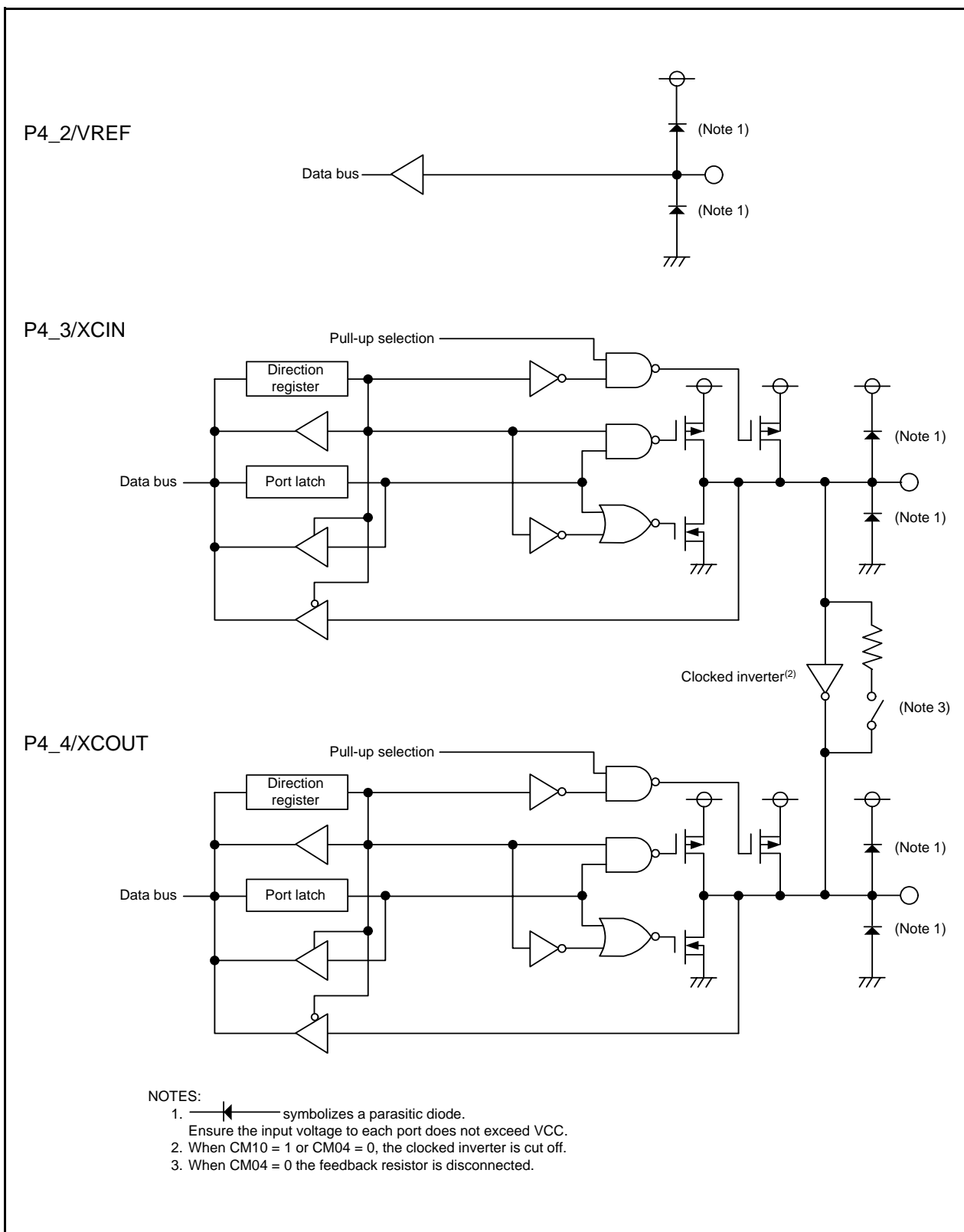

Figure 7.4 Configuration of Programmable I/O Ports (4)

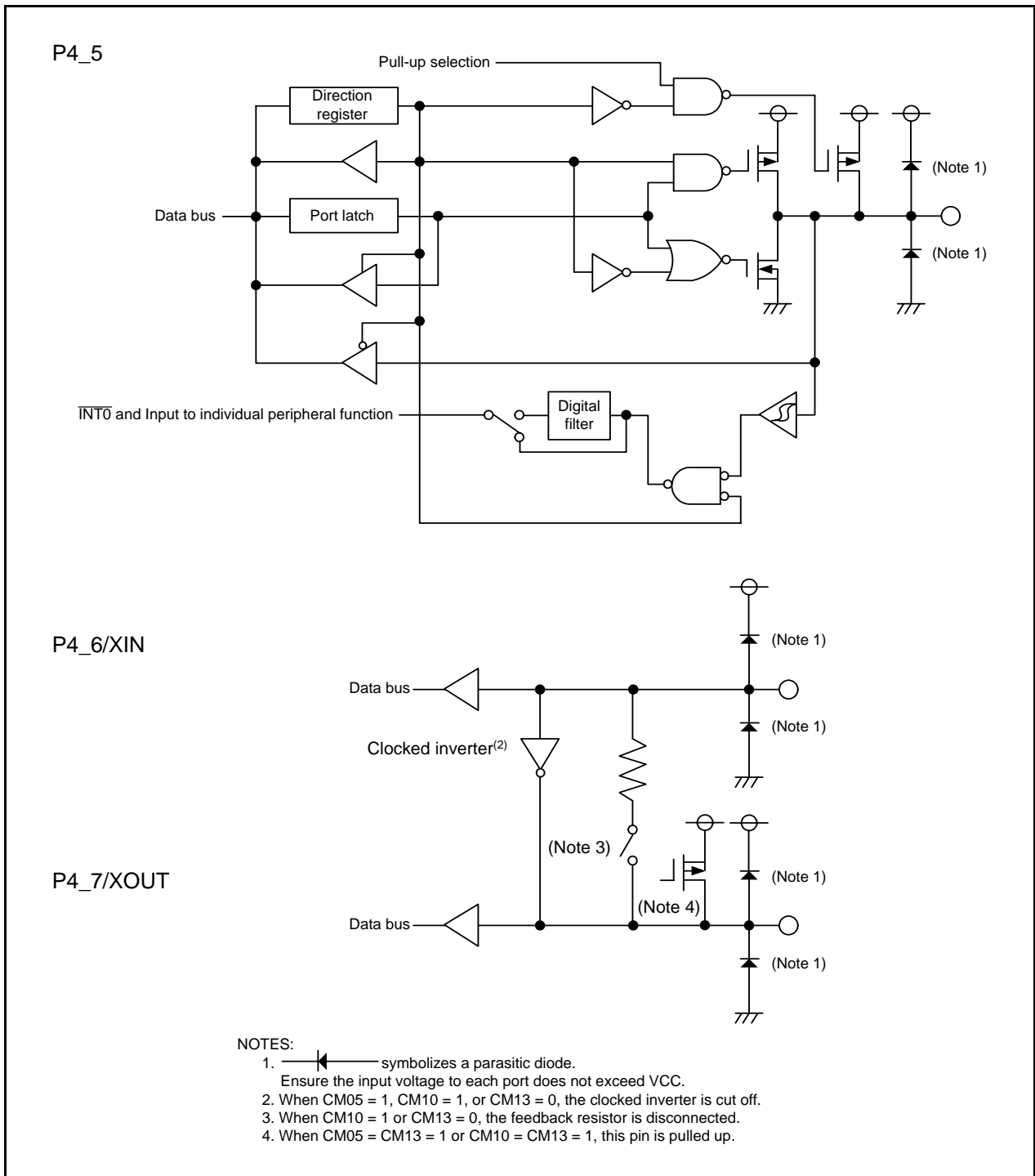

Figure 7.5 Configuration of Programmable I/O Ports (5)

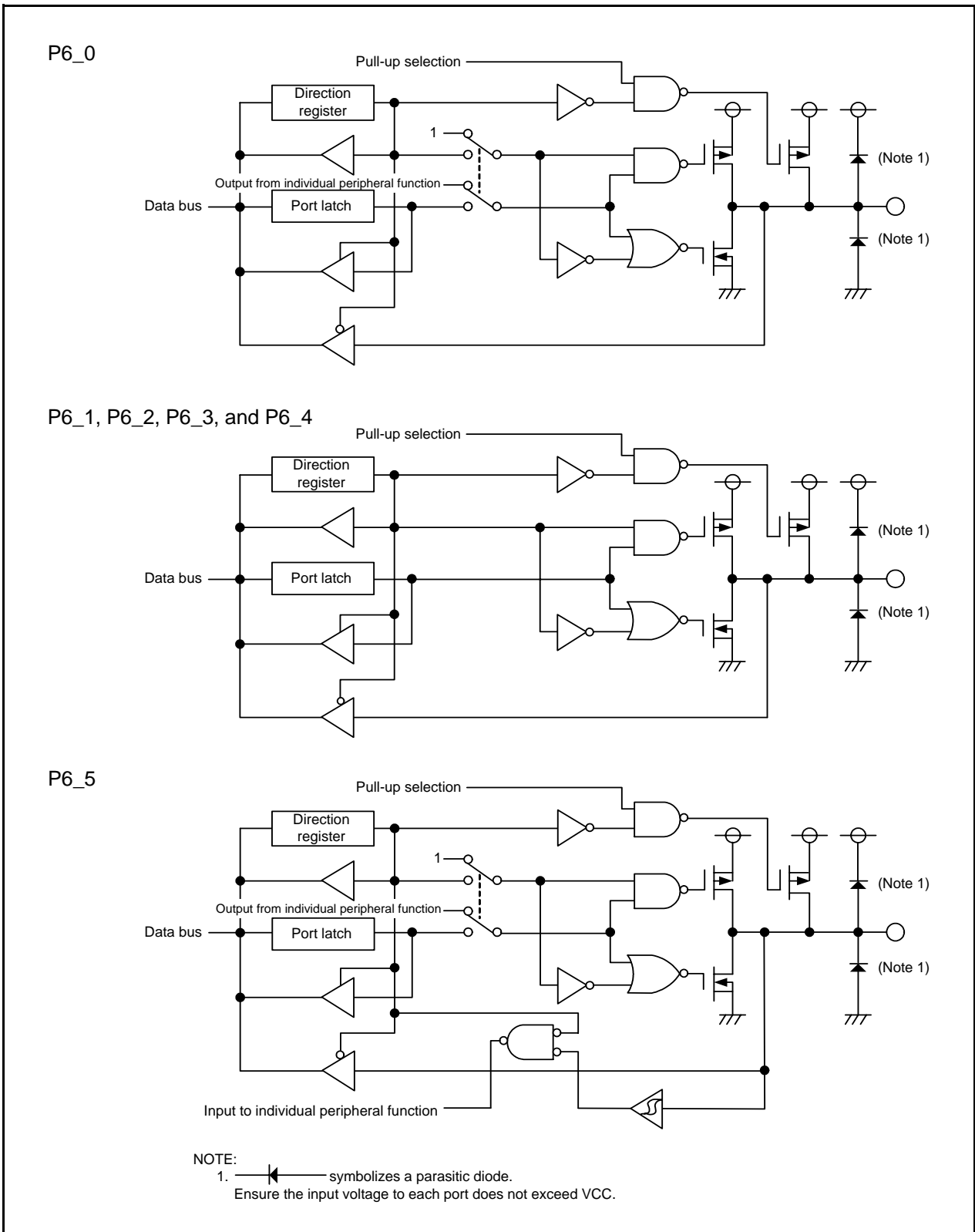

Figure 7.6 Configuration of Programmable I/O Ports (6)

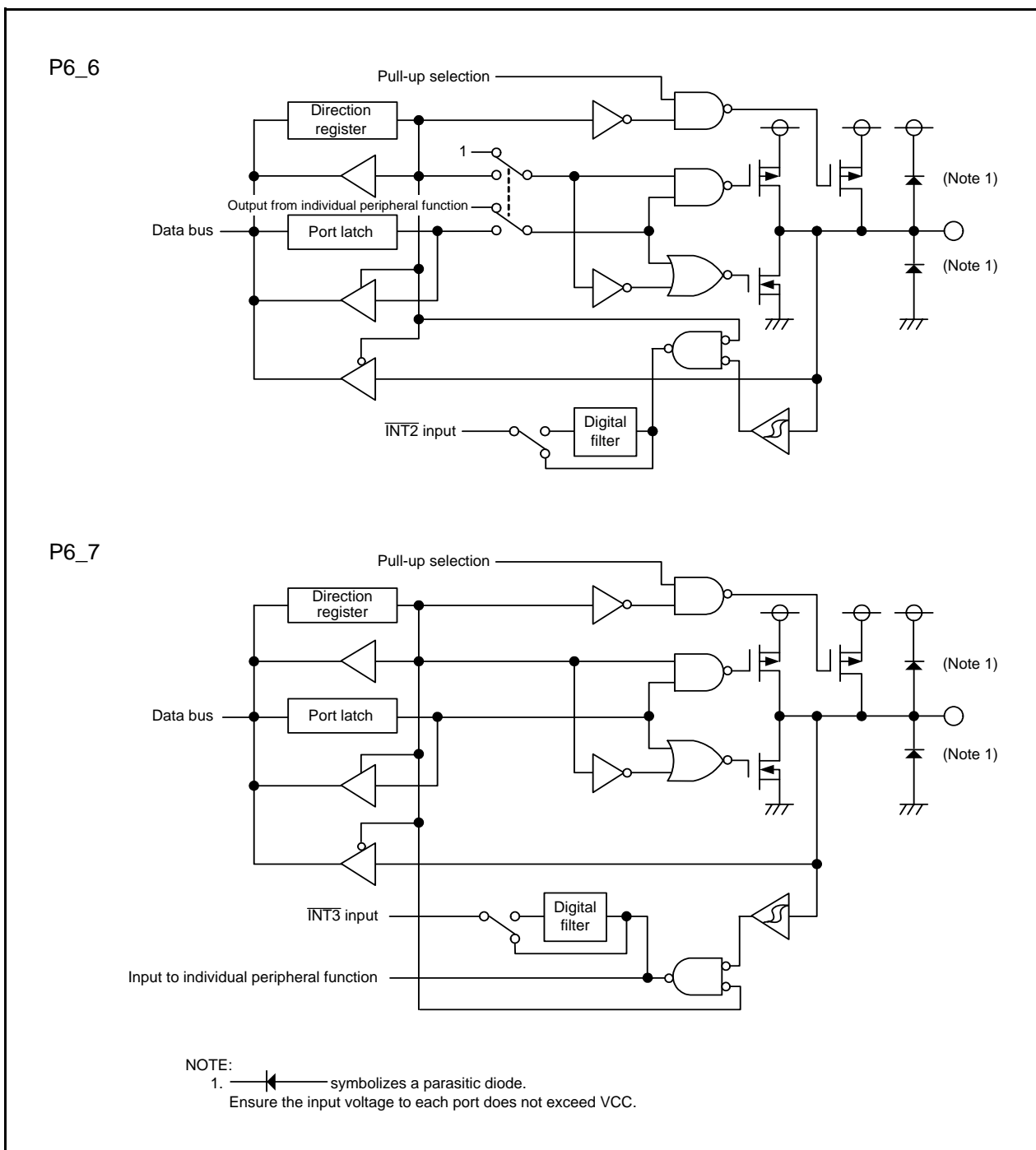

Figure 7.7 Configuration of Programmable I/O Ports (7)

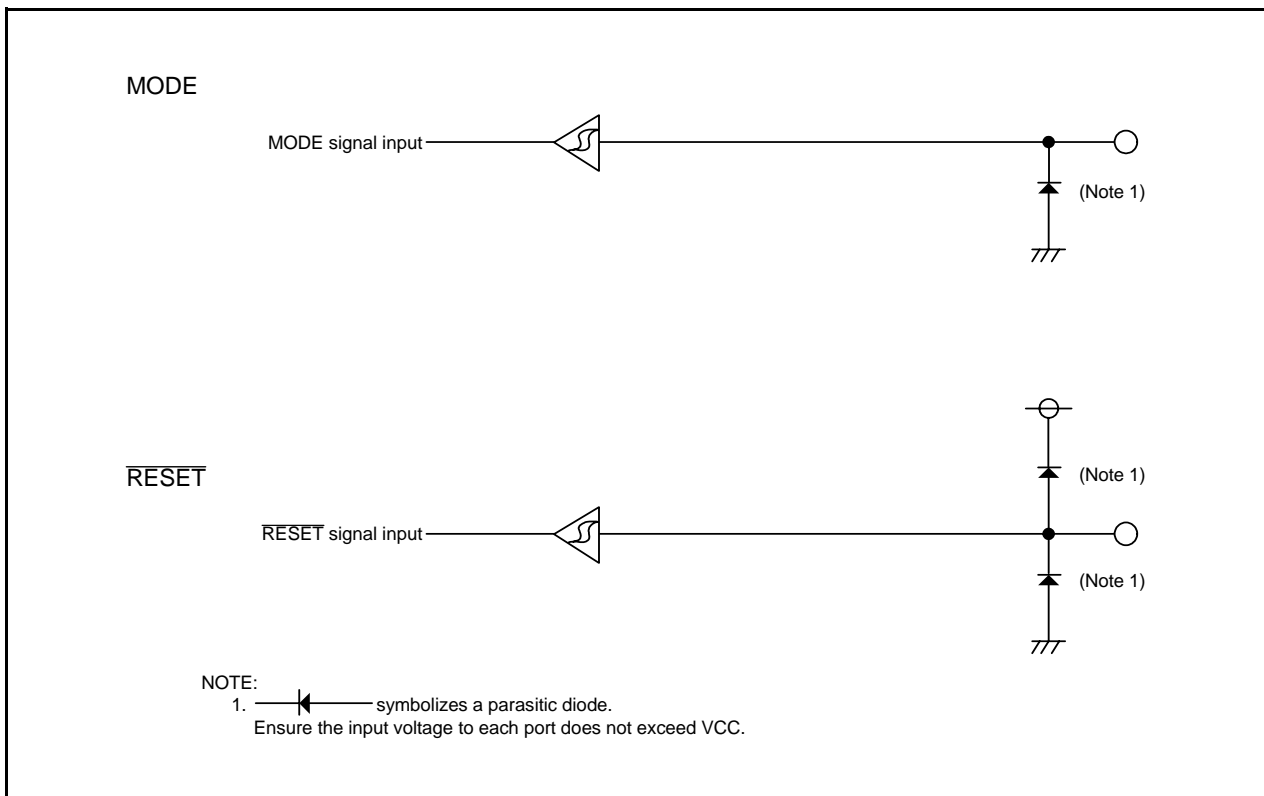

Figure 7.8 Configuration of I/O Pins

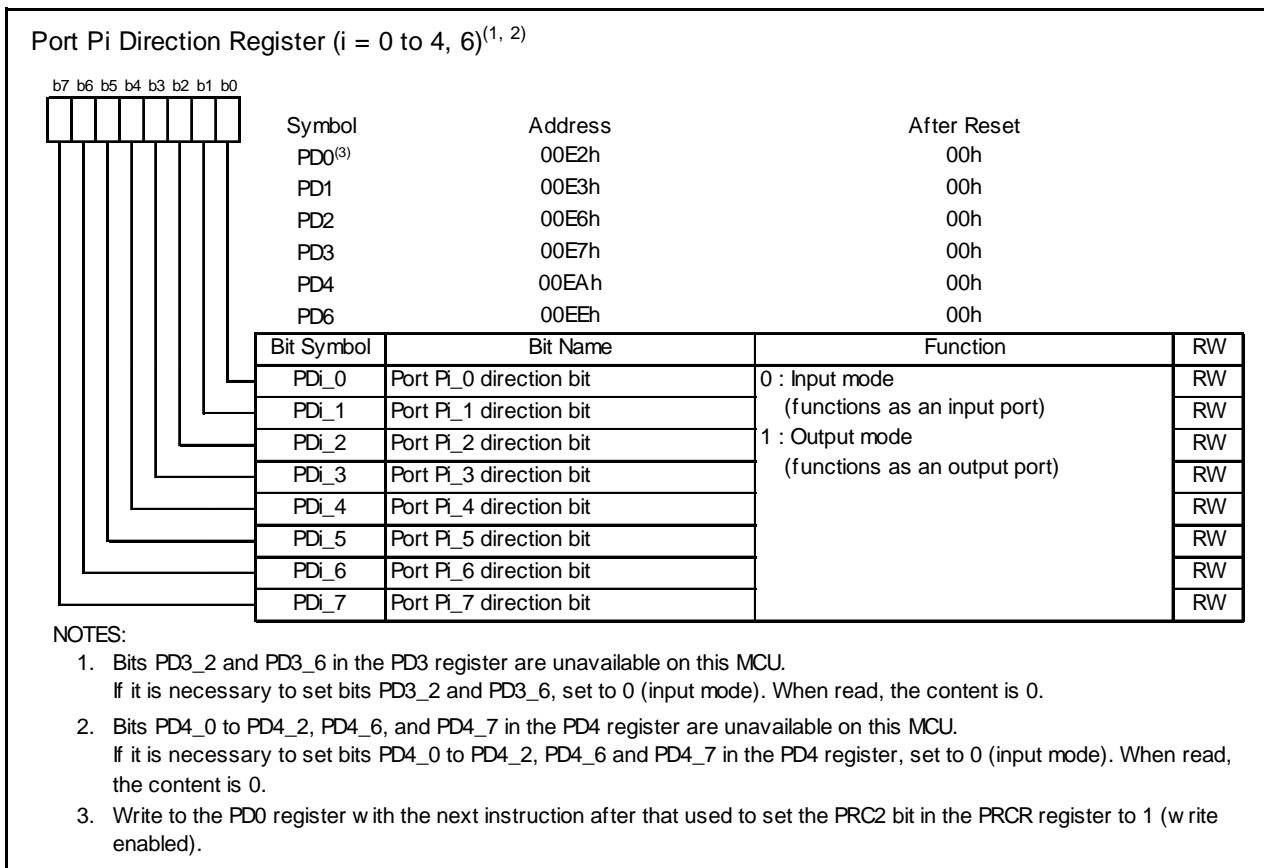

Figure 7.9 PDi (i = 0 to 4 and 6) Registers

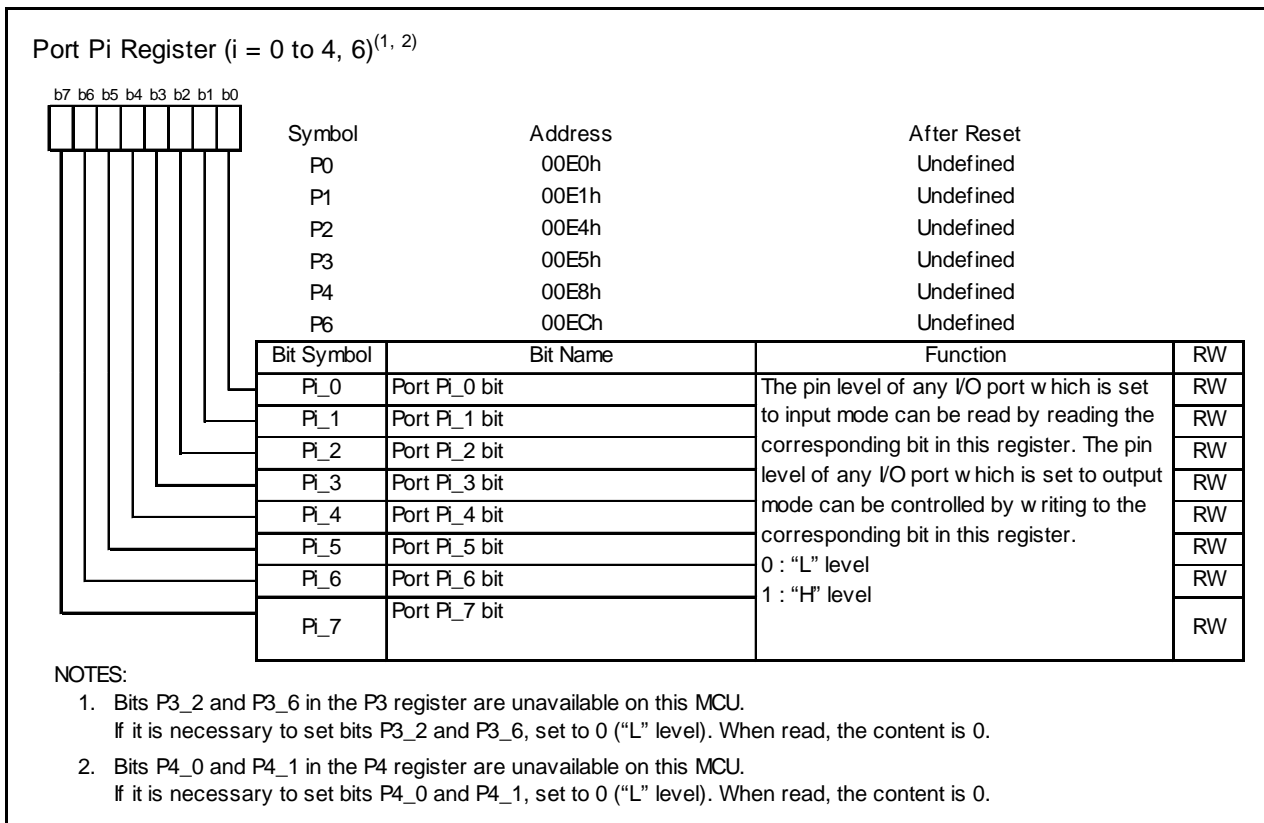
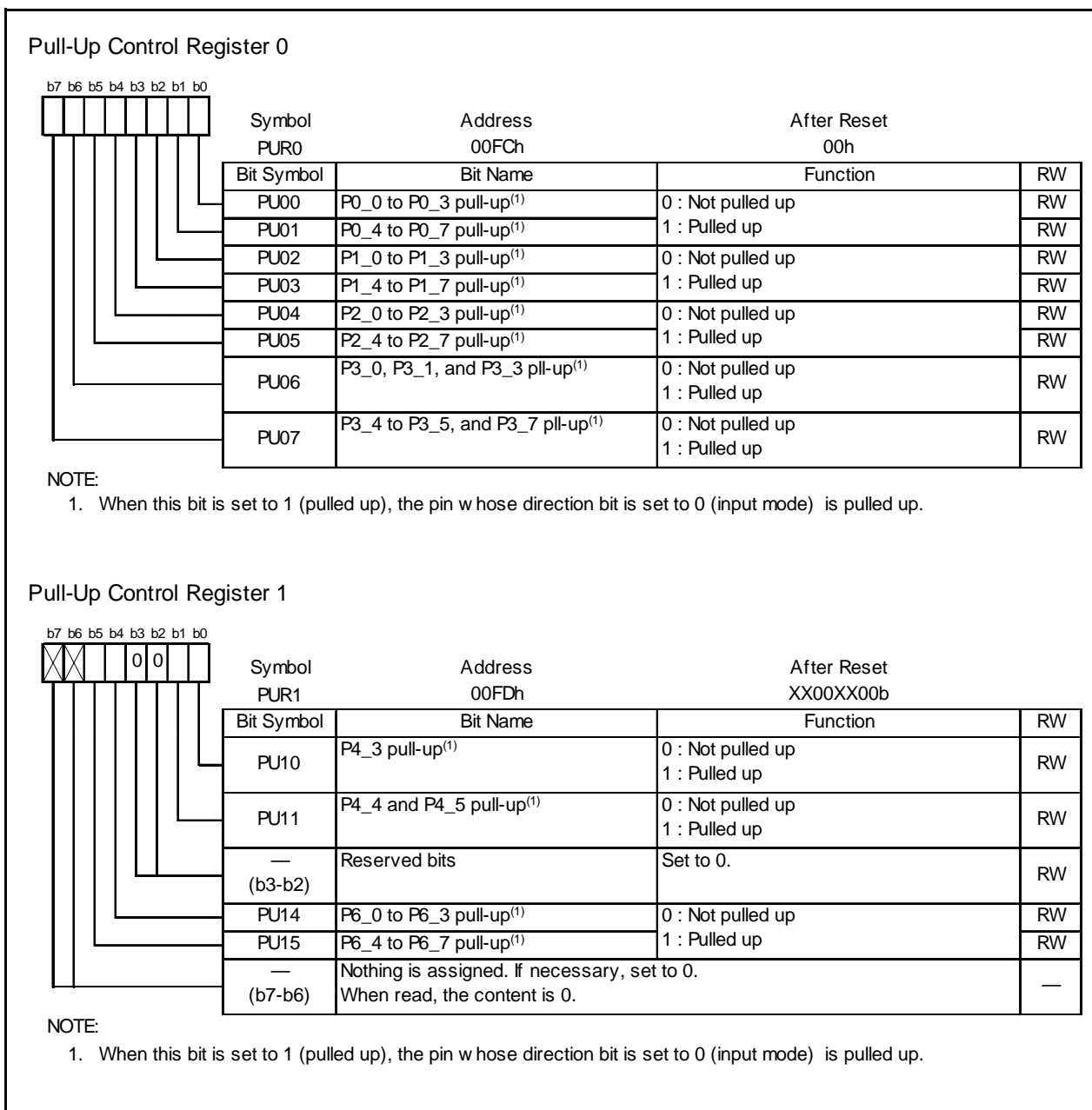

Figure 7.10 Pi (i = 0 to 4 and 6) Registers



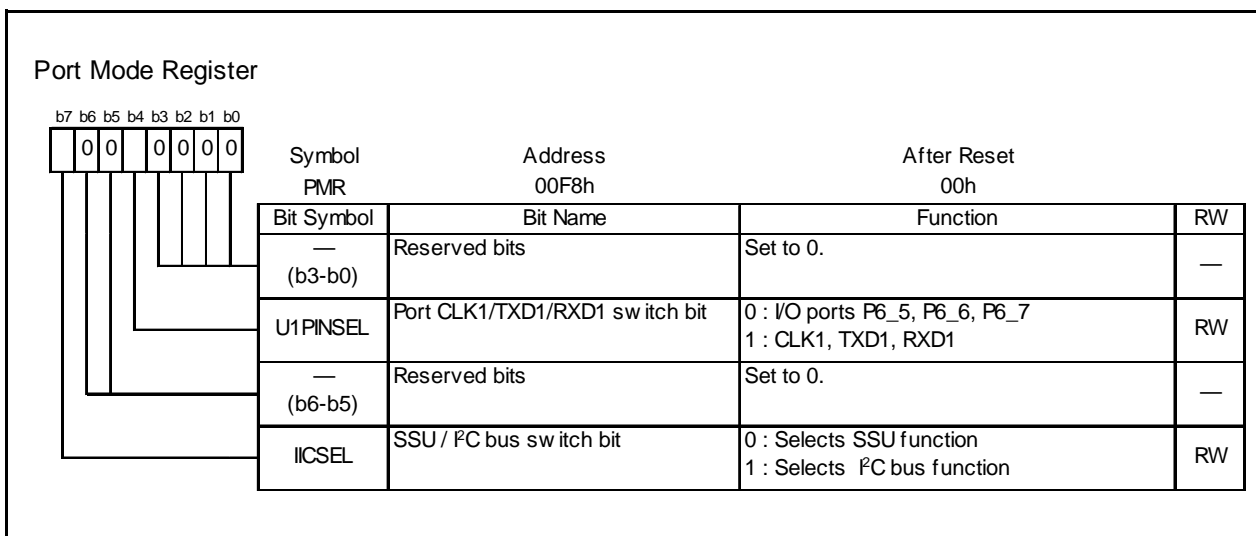

Figure 7.12 PMR Register

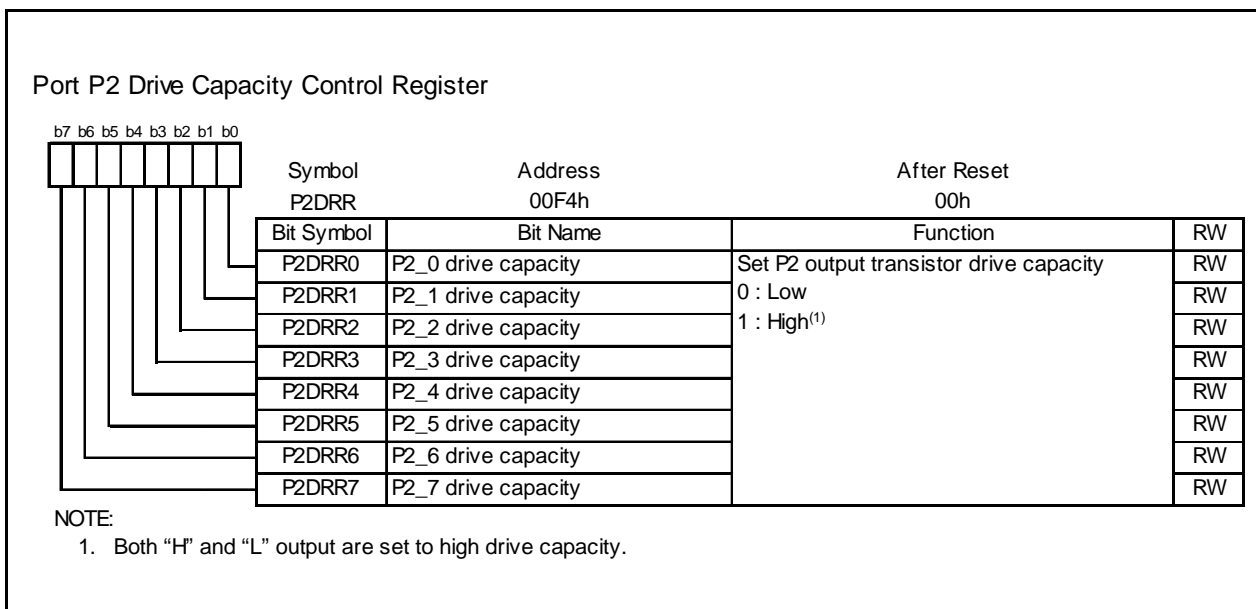

Figure 7.13 P2DRR Register

7.4 Port settings

Tables 7.4 to 7.47 list the port settings.

Table 7.4 Port P0_0/AN7

Register	PD0	ADCON0				Function
Bit	PD0_0	CH2	CH1	CH0	ADGSEL0	
Setting Value	0	X	X	X	X	Input port ⁽¹⁾
	1	X	X	X	X	Output port
	0	1	1	1	0	A/D converter input (AN7)

X: 0 or 1

NOTE:

1. Pulled up by setting the PU00 bit in the PUR0 register to 1.

Table 7.5 Port P0_1/AN6

Register	PD0	ADCON0				Function
Bit	PD0_1	CH2	CH1	CH0	ADGSEL0	
Setting Value	0	X	X	X	X	Input port ⁽¹⁾
	1	X	X	X	X	Output port
	0	1	1	0	0	A/D converter input (AN6)

X: 0 or 1

NOTE:

1. Pulled up by setting the PU00 bit in the PUR0 register to 1.

Table 7.6 Port P0_2/AN5

Register	PD0	ADCON0				Function
Bit	PD0_2	CH2	CH1	CH0	ADGSEL0	
Setting Value	0	X	X	X	X	Input port ⁽¹⁾
	1	X	X	X	X	Output port
	0	1	0	1	0	A/D converter input (AN5)

X: 0 or 1

NOTE:

1. Pulled up by setting the PU00 bit in the PUR0 register to 1.

Table 7.7 Port P0_3/AN4

Register	PD0	ADCON0				Function
Bit	PD0_3	CH2	CH1	CH0	ADGSEL0	
Setting Value	0	X	X	X	X	Input port ⁽¹⁾
	1	X	X	X	X	Output port
	0	1	0	0	0	A/D converter input (AN4)

X: 0 or 1

NOTE:

1. Pulled up by setting the PU00 bit in the PUR0 register to 1.

Table 7.8 Port P0_4/AN3

Register	PD0	ADCON0				Function
Bit	PD0_4	CH2	CH1	CH0	ADGSEL0	
Setting Value	0	X	X	X	X	Input port ⁽¹⁾
	1	X	X	X	X	Output port
	0	0	1	1	0	A/D converter input (AN3)

X: 0 or 1

NOTE:

1. Pulled up by setting the PU01 bit in the PUR0 register to 1.

Table 7.9 Port P0_5/AN2

Register	PD0	ADCON0				Function
Bit	PD0_5	CH2	CH1	CH0	ADGSEL0	
Setting Value	0	X	X	X	X	Input port ⁽¹⁾
	1	X	X	X	X	Output port
	0	0	1	0	0	A/D converter input (AN2)

X: 0 or 1

NOTE:

1. Pulled up by setting the PU01 bit in the PUR0 register to 1.

Table 7.10 Port P0_6/AN1

Register	PD0	ADCON0				Function
Bit	PD0_6	CH2	CH1	CH0	ADGSEL0	
Setting Value	0	X	X	X	X	Input port ⁽¹⁾
	1	X	X	X	X	Output port
	0	0	0	1	0	A/D converter input (AN1)

X: 0 or 1

NOTE:

1. Pulled up by setting the PU01 bit in the PUR0 register to 1.

Table 7.11 Port P0_7/AN0

Register	PD0	ADCON0				Function
Bit	PD0_7	CH2	CH1	CH0	ADGSEL0	
Setting Value	0	X	X	X	X	Input port ⁽¹⁾
	1	X	X	X	X	Output port
	0	0	0	0	0	A/D converter input (AN0)

X: 0 or 1

NOTE:

1. Pulled up by setting the PU01 bit in the PUR0 register to 1.

Table 7.12 Port P1_0/KI0/AN8

Register	PD1	KIEN	ADCON0				Function
Bit	PD1_0	KI0EN	CH2	CH1	CH0	ADGSEL0	
Setting Value	0	X	X	X	X	X	Input port ⁽¹⁾
	1	X	X	X	X	X	Output port
	0	1	X	X	X	X	KI0 input
	0	X	1	0	0	1	A/D converter input (AN8)

X: 0 or 1

NOTE:

1. Pulled up by setting the PU02 bit in the PUR0 register to 1.

Table 7.13 Port P1_1/KI1/AN9

Register	PD1	KIEN	ADCON0				Function
Bit	PD1_1	KI1EN	CH2	CH1	CH0	ADGSEL0	
Setting Value	0	X	X	X	X	X	Input port ⁽¹⁾
	1	X	X	X	X	X	Output port
	0	1	X	X	X	X	KI1 input
	0	X	1	0	1	1	A/D converter input (AN9)

X: 0 or 1

NOTE:

1. Pulled up by setting the PU02 bit in the PUR0 register to 1.

Table 7.14 Port P1_2/KI2/AN10

Register	PD1	KIEN	ADCON0				Function
Bit	PD1_2	KI2EN	CH2	CH1	CH0	ADGSEL0	
Setting Value	0	X	X	X	X	X	Input port ⁽¹⁾
	1	X	X	X	X	X	Output port
	0	1	X	X	X	X	KI2 input
	0	X	1	1	0	1	A/D converter input (AN10)

X: 0 or 1

NOTE:

1. Pulled up by setting the PU02 bit in the PUR0 register to 1.

Table 7.15 Port P1_3/KI3/AN11

Register	PD1	KIEN	ADCON0				Function
Bit	PD1_3	KI3EN	CH2	CH1	CH0	ADGSEL0	
Setting Value	0	X	X	X	X	X	Input port ⁽¹⁾
	1	X	X	X	X	X	Output port
	0	1	X	X	X	X	KI3 input
	0	X	1	1	1	1	A/D converter input (AN11)

X: 0 or 1

NOTE:

1. Pulled up by setting the PU02 bit in the PUR0 register to 1.

Table 7.16 Port P1_4/TXD0

Register	PD1	U0MR			Function	
Bit	PD1_4	SMD2	SMD1	SMD0		
Setting Value	0	0	0	0	Input port ⁽¹⁾	
	1	0	0	0	Output port	
	X	X	0	0	1	TXD0 output ⁽²⁾
			1	0	0	
			1	0	1	
			1	1	0	

X: 0 or 1

NOTES:

1. Pulled up by setting the PU03 bit in the PUR0 register to 1.
2. N-channel open drain output by setting the NCH bit in the U0C0 register to 1.

Table 7.17 Port P1_5/RXD0/(TRAIO)/(INT1)

Register	PD1	TRAIOC		TRAMR			INTEN	Function
Bit	PD1_5	TIOSEL	TOPCR	TMOD2	TMOD1	TMOD0	INT1EN	
Setting Value	0	0	X	X	X	X	X	Input port ⁽¹⁾
		X	1	X	X	X		
		X	X	Other than 001b				
	1	X	X	Other than 001b			X	Output port
	1	X	1	X	X	X		
	0	X	X	Other than 001b			X	RXD0 input
	0	1	X	Other than 001b			X	TRAIO input
	0	1	X	Other than 001b			1	TRAIO/INT1 input
	X	1	0	0	0	1	X	TRAIO pulse output

X: 0 or 1

NOTE:

1. Pulled up by setting the PU03 bit in the PUR0 register to 1.

Table 7.18 Port P1_6/CLK0

Register	PD1	U0MR				Function
Bit	PD1_6	SMD2	SMD1	SMD0	CKDIR	
Setting Value	0	Other than 001b			X	Input port ⁽¹⁾
		X	X	X	1	
	1	Other than 001b			X	Output port
	0	X	X	X	1	CLK0 (external clock) input
	X	0	0	1	0	CLK0 (internal clock) output

X: 0 or 1

NOTE:

1. Pulled up by setting the PU03 bit in the PUR0 register to 1.

Table 7.19 Port P1_7/TRAIO/INT1

Register	PD1	TRAIOC		TRAMR			INTEN	Function
Bit	PD1_7	TIOSEL	TOPCR	TMOD2	TMOD1	TMOD0	INT1EN	
Setting Value	0	1	X	X	X	X	X	Input port ⁽¹⁾
		X	1	X	X	X		
		X	X	Other than 001b				
	1	X	X	Other than 001b			X	Output port
	1	X	1	X	X	X	X	
	0	0	X	Other than 001b			X	TRAIO input
	0	0	X	Other than 001b			1	TRAIO/INT1 input
	X	0	0	0	0	1	X	TRAIO pulse output

X: 0 or 1

NOTE:

1. Pulled up by setting the PU03 bit in the PUR0 register to 1.

Table 7.20 Port P2_0/TRDIOA0/TRDCLK

Register	PD2	TRDOER1	TRDFCR				TRDIOA0			Function
Bit	PD2_0	EA0	CMD1	CMD0	STCLK	PWM3	IOA2	IOA1	IOA0	
Setting Value	0	1	X	X	X	X	X	X	X	Input port ⁽¹⁾
	1	1	X	X	X	X	X	X	X	Output port ⁽²⁾
	0	X	0	0	0	1	1	X	X	Timer mode (input capture function)
	0	X	X	X	1	1	0	0	0	External clock input (TRDCLK)
	X	0	0	0	0	0	0	X	X	PWM3 mode waveform output ⁽²⁾
	X	0	0	0	0	0	1	0	0	1

X: 0 or 1

NOTES:

1. Pulled up by setting the PU04 bit in the PUR0 register to 1.
2. Output drive capacity high by setting the P2DRR0 bit in the P2DRR register to 1.

Table 7.21 Port P2_1/TRDIOB0

Register	PD2	TRDOER1	TRDFCR			TRDPMR	TRDIOA0			Function	
Bit	PD2_1	EB0	CMD1	CMD0	PWM3	PWMB0	IOB2	IOB1	IOB0		
Setting Value	0	1	X	X	X	X	X	X	X	Input port ⁽¹⁾	
	1	1	X	X	X	X	X	X	X	Output port ⁽²⁾	
	0	X	0	0	1	0	1	X	X	Timer mode (input capture function)	
	X	0	1	0	X	X	X	X	X	X	Complementary PWM mode waveform output
			1	1							
	X	0	0	0	1	X	X	X	X	X	Reset synchronous PWM mode waveform output
	X	0	0	0	0	0	X	X	X	X	PWM3 mode waveform output ⁽²⁾
	X	0	0	0	0	1	1	X	X	X	PWM mode waveform output ⁽²⁾
X	0	0	0	1	0	0	0	0	1	Timer mode waveform output (output compare function) ⁽²⁾	
							0	1	X		

X: 0 or 1

NOTES:

1. Pulled up by setting the PU04 bit in the PUR0 register to 1.
2. Output drive capacity high by setting the P2DRR1 bit in the P2DRR register to 1.

Table 7.22 Port P2_2/TRDIOC0

Register	PD2	TRDOER1	TRDFCR			TRDPMR	TRDIORC0			Function	
Bit	PD2_2	EC0	CMD1	CMD0	PWM3	PWMC0	IOC2	IOC1	IOC0		
Setting Value	0	1	X	X	X	X	X	X	X	Input port ⁽¹⁾	
	1	1	X	X	X	X	X	X	X	Output port ⁽²⁾	
	0	X	0	0	1	0	1	X	X	Timer mode (input capture function)	
	X	0	1	0	X	X	X	X	X	X	Complementary PWM mode waveform output ⁽²⁾
			1	1							
	X	0	0	1	X	X	X	X	X	Reset synchronous PWM mode waveform output ⁽²⁾	
	X	0	0	0	1	1	X	X	X	PWM mode waveform output ⁽²⁾	
X	0	0	0	1	0	0	0	1	X	Timer mode waveform output (output compare function) ⁽²⁾	
						0	1				

X: 0 or 1

NOTES:

1. Pulled up by setting the PU04 bit in the PUR0 register to 1.
2. Output drive capacity high by setting the P2DRR2 bit in the P2DRR register to 1.

Table 7.23 Port P2_3/TRDIOD0

Register	PD2	TRDOER1	TRDFCR			TRDPMR	TRDIORC0			Function	
Bit	PD2_3	ED0	CMD1	CMD0	PWM3	PWMD0	IOD2	IOD1	IOD0		
Setting Value	0	1	X	X	X	X	X	X	X	Input port ⁽¹⁾	
	1	1	X	X	X	X	X	X	X	Output port ⁽²⁾	
	0	X	0	0	1	0	1	X	X	Timer mode (input capture function)	
	X	0	1	0	X	X	X	X	X	X	Complementary PWM mode waveform output ⁽²⁾
			1	1							
	X	0	0	1	X	X	X	X	X	Reset synchronous PWM mode waveform output ⁽²⁾	
	X	0	0	0	1	1	X	X	X	PWM mode waveform output ⁽²⁾	
X	0	0	0	1	0	0	0	1	X	Timer mode waveform output (output compare function) ⁽²⁾	
						0	1				

X: 0 or 1

NOTES:

1. Pulled up by setting the PU04 bit in the PUR0 register to 1.
2. Output drive capacity high by setting the P2DRR3 bit in the P2DRR register to 1.

Table 7.24 Port P2_4/TRDIOA1

Register	PD2	TRDOER1	TRDFCR			TRDIORA1			Function	
Bit	PD2_4	EA1	CMD1	CMD0	PWM3	IOA2	IOA1	IOA0		
Setting Value	0	1	X	X	X	X	X	X	Input port ⁽¹⁾	
	1	1	X	X	X	X	X	X	Output port ⁽²⁾	
	0	X	0	0	1	1	X	X	Timer mode (input capture function)	
	X	0	1	0	X	X	X	X	X	Complementary PWM mode waveform output ⁽²⁾
			1	1						
	X	0	0	1	X	X	X	X	Reset synchronous PWM mode waveform output ⁽²⁾	
X	0	0	0	1	0	0	1	X	Timer mode waveform output (output compare function) ⁽²⁾	
					0	1				

X: 0 or 1

NOTES:

1. Pulled up by setting the PU05 bit in the PUR0 register to 1.
2. Output drive capacity high by setting the P2DRR4 bit in the P2DRR register to 1.

Table 7.25 Port P2_5/TRDIOB1

Register	PD2	TRDOER1	TRDFCR			TRDPMR	TRDIOA1			Function	
Bit	PD2_5	EB1	CMD1	CMD0	PWM3	PWMB1	IOB2	IOB1	IOB0		
Setting Value	0	1	X	X	X	X	X	X	X	Input port ⁽¹⁾	
	1	1	X	X	X	X	X	X	X	Output port ⁽²⁾	
	0	X	0	0	1	0	1	X	X	Timer mode (input capture function)	
	X	0	1	0	X	X	X	X	X	X	Complementary PWM mode waveform output ⁽²⁾
			1	1							
	X	0	0	1	X	X	X	X	X	Reset synchronous PWM mode waveform output ⁽²⁾	
	X	0	0	0	1	1	X	X	X	PWM mode waveform output ⁽²⁾	
X	0	0	0	1	0	0	0	1	Timer mode waveform output (output compare function) ⁽²⁾		
						0	1	X			

X: 0 or 1

NOTES:

1. Pulled up by setting the PU05 bit in the PUR0 register to 1.
2. Output drive capacity high by setting the P2DRR5 bit in the P2DRR register to 1.

Table 7.26 Port P2_6/TRDIOC1

Register	PD2	TRDOER1	TRDFCR			TRDPMR	TRDIOC1			Function	
Bit	PD2_6	EC1	CMD1	CMD0	PWM3	PWMC1	IOC2	IOC1	IOC0		
Setting Value	0	1	X	X	X	X	X	X	X	Input port ⁽¹⁾	
	1	1	X	X	X	X	X	X	X	Output port ⁽²⁾	
	0	X	0	0	1	0	1	X	X	Timer mode (input capture function)	
	X	0	1	0	X	X	X	X	X	X	Complementary PWM mode waveform output ⁽²⁾
			1	1							
	X	0	0	1	X	X	X	X	X	Reset synchronous PWM mode waveform output ⁽²⁾	
	X	0	0	0	1	1	X	X	X	PWM mode waveform output ⁽²⁾	
X	0	0	0	1	0	0	0	1	Timer mode waveform output (output compare function) ⁽²⁾		
						0	1	X			

X: 0 or 1

NOTES:

1. Pulled up by setting the PU05 bit in the PUR0 register to 1.
2. Output drive capacity high by setting the P2DRR6 bit in the P2DRR register to 1.

Table 7.27 Port P2_7/TRDIOD1

Register	PD2	TRDOER1	TRDFCR			TRDPMR	TRDIOC1			Function	
Bit	PD2_7	ED1	CMD1	CMD0	PWM3	PWMD1	IOD2	IOD1	IOD0		
Setting Value	0	1	X	X	X	X	X	X	X	Input port ⁽¹⁾	
	1	1	X	X	X	X	X	X	X	Output port ⁽²⁾	
	0	X	0	0	1	0	1	X	X	Timer mode (input capture function)	
	X	0	1	0	X	X	X	X	X	X	Complementary PWM mode waveform output ⁽²⁾
			1	1							
	X	0	0	1	X	X	X	X	X	Reset synchronous PWM mode waveform output ⁽²⁾	
	X	0	0	0	1	1	X	X	X	PWM mode waveform output ⁽²⁾	
X	0	0	0	1	0	0	0	1	Timer mode waveform output (output compare function) ⁽²⁾		
						0	1	X			

X: 0 or 1

NOTES:

1. Pulled up by setting the PU05 bit in the PUR0 register to 1.
2. Output drive capacity high by setting the P2DRR7 bit in the P2DRR register to 1.

Table 7.28 Port P3_0/TRAO

Register	PD3	TRAIOC	Function
Bit	PD3_0	TOENA	
Setting Value	0	0	Input port ⁽¹⁾
	1	0	Output port
	X	1	TRAO output

X: 0 or 1

NOTE:

1. Pulled up by setting the PU06 bit in the PUR0 register to 1.

Table 7.29 Port P3_1/TRBO

Register	PD3	TRBMR		TRBIOC	Function
Bit	PD3_1	TMOD1	TMOD0	TOCNT	
Setting Value	0	0	0	X	Input port ⁽¹⁾
	1	0	0	X	Output port
	X	Other than 00b		0	
	X	Other than 00b		1	TRBO output

X: 0 or 1

NOTE:

1. Pulled up by setting the PU06 bit in the PUR0 register to 1.

Table 7.30 Port P3_3/SSI

Register	PD3	Clock Synchronous Serial I/O with Chip Select (Refer to Table 16.4 Association between Communication Modes and I/O Pins.)		PMR	Function
Bit	PD3_3	SSI output control	SSI input control	IICSEL	
Setting Value	0	0	0	0	Input port ⁽¹⁾
	1	0	0	0	Output port ⁽²⁾
	X	0	1	0	SSI input
	X	1	0	0	SSI output ⁽²⁾

X: 0 or 1

NOTES:

1. Pulled up by setting the PU06 bit in the PUR0 register to 1.
2. N-channel open drain output by setting the SOOS bit in the SSMR2 register to 1 when this pin functions as output.

Table 7.31 Port P3_4/SDA/ $\overline{\text{SCS}}$

Register	PD3	SSMR2		PMR	ICCR1	Function	
Bit	PD3_4	CSS1	CSS0	IICSEL	ICE		
Setting Value	0	0	0	0	X	Input port ⁽¹⁾	
	0	0	0	X	0		
	1	0	0	0	X	Output port ⁽²⁾	
	1	0	0	X	0		
	X	0	1	0	X	$\overline{\text{SCS}}$ input	
	X	1	1	0	0	X	$\overline{\text{SCS}}$ output ⁽²⁾
			1	1			
X	X	X	X	1	1	SDA input/output	

X: 0 or 1

NOTES:

1. Pulled up by setting the PU07 bit in the PUR0 register to 1.
2. N-channel open drain output by setting the CSOS bit in the SSMR2 register to 1 when this pin functions as output.

Table 7.32 Port P3_5/SCL/SSCK

Register	PD3	Clock Synchronous Serial I/O with Chip Select (Refer to Table 16.4 Association between Communication Modes and I/O Pins.)		PMR	ICCR1	Function
Bit	PD3_5	SSCK output control	SSCK input control	IICSEL	ICE	
Setting Value	0	0	0	0	X	Input port ⁽¹⁾
	0	0	0	X	0	
	1	0	0	0	X	Output port ⁽²⁾
	1	0	0	X	0	
	X	0	1	0	0	SSCK input
	X	1	0	0	0	SSCK output ⁽²⁾
	X	1	0	0	1	1

X: 0 or 1

NOTES:

1. Pulled up by setting the PU07 bit in the PUR0 register to 1.
2. N-channel open drain output by setting the CSOS bit in the SSMR2 register to 1 when this pin functions as output.

Table 7.33 Port P3_7/SSO

Register	PD3	Clock Synchronous Serial I/O with Chip Select (Refer to Table 16.4 Association between Communication Modes and I/O Pins.)		SSMR2	PMR	Function
Bit	PD3_7	SSO output control	SSO input control	SOOS	IICSEL	
Setting Value	0	0	0	X	0	Input port ⁽¹⁾
	0	X	X	X	1	
	1	0	0	0	0	Output port
	1	X	X	0	1	
	X	0	1	0	0	SSO input
	X	1	0	0	0	SSO output (CMOS output)
	X	1	0	0	1	0

X: 0 or 1

NOTE:

1. Pulled up by setting the PU07 bit in the PUR0 register to 1.

Table 7.34 Port P4_2/VREF

Register	ADCON1	Function
Bit	VCUT	
Setting Value	0	Input port
	1	Input port/VREF input

Table 7.35 Port P4_3/XCIN

Register	PD4	CM0	CM1		Circuit specifications		Function	
Bit	PD4_3	CM04	CM10	CM12	Oscillation buffer	Feedback resistor		
Setting Value	0	0	X	X	OFF	OFF	Input port ⁽¹⁾	
	1	0	X	X	OFF	OFF	Output port	
	X	1	0	0	ON	ON	XCIN-XCOUT oscillation (on-chip feedback resistor enabled)	
	X	1	0	1	ON	OFF	XCIN-XCOUT oscillation (on-chip feedback resistor disabled)	
	X	1	1	0	0	OFF	ON	XCIN-XCOUT oscillation stop
				1	1	OFF	OFF	
	X	1	0	0	0	ON	ON	External XCIN input
				1	1	ON	OFF	

X: 0 or 1

NOTE:

1. Pulled up by setting the PU10 bit in the PUR1 register to 1.

Table 7.36 Port P4_4/XCOUT

Register	PD4	CM0	CM1		Circuit specifications		Function
Bit	PD4_4	CM04	CM10	CM12	Oscillation buffer	Feedback resistor	
Setting Value	0	0	X	X	OFF	OFF	Input port ⁽¹⁾
	1	0	X	X	OFF	OFF	Output port
	X	1	0	0	ON	ON	XCIN-XCOUT oscillation (on-chip feedback resistor enabled)
	X	1	0	1	ON	OFF	XCIN-XCOUT oscillation (on-chip feedback resistor disabled)
	X	1	1	0	OFF	ON	XCIN-XCOUT oscillation stop
				1	OFF	OFF	
X	1	0	0	ON	ON	External XCOUT output (inverted output of XCIN) ⁽²⁾	
			1	ON	OFF		

X: 0 or 1

NOTES:

1. Pulled up by setting the PU11 bit in the PUR1 register to 1.
2. Since the XCIN-XCOUT oscillation buffer operates with internal step-down power, the XCOUT output level cannot be used as the CMOS level signal directly.

Table 7.37 Port P4_5/ $\overline{\text{INT0}}$

Register	PD4	INTEN	Function
Bit	PD4_5	INT0EN	
Setting Value	0	X	Input port ⁽¹⁾
	1	X	Output port
	0	1	$\overline{\text{INT0}}$ input

X: 0 or 1

NOTE:

1. Pulled up by setting the PU11 bit in the PUR1 register to 1.

Table 7.38 Port P4_6/XIN

Register	CM1		CM0	Circuit specifications		Function
Bit	CM13	CM10	CM05	Oscillation buffer	Feedback resistor	
Setting Value	0	X	X	OFF	OFF	Input port
	1	0	0	ON	ON	XIN-XOUT oscillation
	1	0	1	OFF	ON	External XIN input
	1	1	0	OFF	OFF	XIN-XOUT oscillation stop
	1	1	1	OFF	OFF	XIN-XOUT oscillation stop

X: 0 or 1

Table 7.39 Port P4_7/XOUT

Register	CM1		CM0	Circuit specifications		Function
Bit	CM13	CM10	CM05	Oscillation buffer	Feedback resistor	
Setting Value	0	X	X	OFF	OFF	Input port
	1	0	0	ON	ON	XIN-XOUT oscillation
	1	0	1	OFF	ON	XOUT is "H" pull-up
	1	1	0	OFF	OFF	XIN-XOUT oscillation stop
	1	1	1	OFF	OFF	XIN-XOUT oscillation stop

X: 0 or 1

Table 7.40 Port P6_0/TREO

Register	PD6	TRECR1	Function
Bit	PD6_0	TOENA	
Setting Value	0	0	Input port ⁽¹⁾
	1	0	Output port
	X	1	TREO output

X: 0 or 1

NOTE:

1. Pulled up by setting the PU14 bit in the PUR1 register to 1.

Table 7.41 Port P6_1

Register	PD6	Function
Bit	PD6_1	
Setting Value	0	Input port ⁽¹⁾
	1	Output port

NOTE:

1. Pulled up by setting the PU14 bit in the PUR1 register to 1.

Table 7.42 Port P6_2

Register	PD6	Function
Bit	PD6_2	
Setting Value	0	Input port ⁽¹⁾
	1	Output port

NOTE:

1. Pulled up by setting the PU14 bit in the PUR1 register to 1.

Table 7.43 Port P6_3

Register	PD6	Function
Bit	PD6_3	
Setting Value	0	Input port ⁽¹⁾
	1	Output port

NOTE:

1. Pulled up by setting the PU14 bit in the PUR1 register to 1.

Table 7.44 Port P6_4

Register	PD6	Function
Bit	PD6_4	
Setting Value	0	Input port ⁽¹⁾
	1	Output port

NOTE:

1. Pulled up by setting the PU15 bit in the PUR1 register to 1.

Table 7.45 Port P6_5/CLK1

Register	PD6	PMR	U1MR				Function
Bit	PD6_5	U1PINSEL	SMD2	SMD1	SMD0	CKDIR	
Setting Value	0	X	Other than 001b			X	Input port ⁽¹⁾
		0	X	X	X	X	
		X	X	X	X	1	
	1	X	Other than 001b			X	Output port
		0	X	X	X	0	
		X	X	X	X	0	
	0	1	X	X	X	1	CLK1 (external clock) input
X	1	0	0	1	0	CLK1 (internal clock) output	

X: 0 or 1

NOTE:

1. Pulled up by setting the PU15 bit in the PUR1 register to 1.

Table 7.46 Port P6_6/INT2/TXD1

Register	PD6	PMR	U1MR			U1C0	INTEN	Function
Bit	PD6_6	U1PINSEL	SMD2	SMD1	SMD0	NCH	INT2EN	
Setting Value	0	X	0	0	0	X	X	Input port ⁽¹⁾
		0	X	X	X			
	1	X	0	0	0	X	X	Output port
		0	X	X	X			
	0	X	X	X	X	X	1	INT2 input
	X	1	0	0	1	0	X	TXD1 output (CMOS output)
			1	0	0			
			1	0	1			
	X	1	1	1	0	1	X	TXD1 output (N-channel open-drain output)
			0	0	1			
			1	0	0			
				1	0	1		
			1	0	1			
			1	1	0			

X: 0 or 1

NOTE:

1. Pulled up by setting the PU15 bit in the PUR1 register to 1.

Table 7.47 Port P6_7/INT3/RXD1

Register	PD6	PMR	INTEN	Function
Bit	PD6_7	U1PINSEL	INT3EN	
Setting Value	0	X	X	Input port ⁽¹⁾
	1	X	X	Output port
	0	X	1	INT3 input
	0	1	X	RXD1 input

X: 0 or 1

NOTE:

1. Pulled up by setting the PU15 bit in the PUR1 register to 1.

7.5 Unassigned Pin Handling

Table 7.48 lists Unassigned Pin Handling.

Table 7.48 Unassigned Pin Handling

Pin Name	Connection
Ports P0 to P2, P3_0, P3_1, P3_3 to P3_7, P4_3 to P4_5, P6	<ul style="list-style-type: none"> • After setting to input mode, connect each pin to VSS via a resistor (pull-down) or connect each pin to VCC via a resistor (pull-up).(2) • After setting to output mode, leave these pins open.(1,2)
Ports P4_6, P4_7	Connect to VCC via a pull-up resistor(2)
Port P4_2, VREF	Connect to VCC
RESET ⁽³⁾	Connect to VCC via a pull-up resistor(2)
NC	Open

NOTES:

1. If these ports are set to output mode and left open, they remain in input mode until they are switched to output mode by a program. The voltage level of these pins may be undefined and the power current may increase while the ports remain in input mode. The content of the direction registers may change due to noise or program runaway caused by noise. In order to enhance program reliability, the program should periodically repeat the setting of the direction registers.
2. Connect these unassigned pins to the MCU using the shortest wire length (2 cm or less) possible.
3. When the power-on reset function is in use.

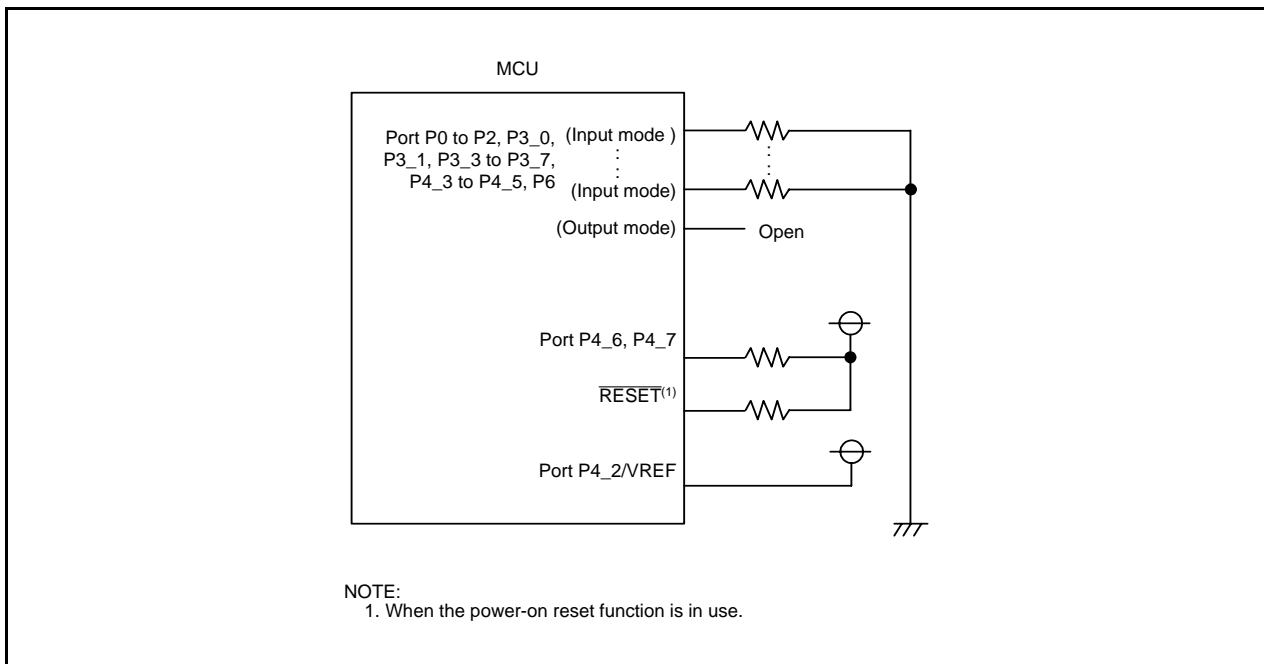

Figure 7.14 Unassigned Pin Handling

8. Processor Mode

8.1 Processor Modes

Single-chip mode can be selected as the processor mode.

Table 8.1 lists Features of Processor Mode. Figure 8.1 shows the PM0 Register and Figure 8.2 shows the PM1 Register.

Table 8.1 Features of Processor Mode

Processor Mode	Accessible Areas	Pins Assignable as I/O Port Pins
Single-chip mode	SFR, internal RAM, internal ROM	All pins are I/O ports or peripheral function I/O pins

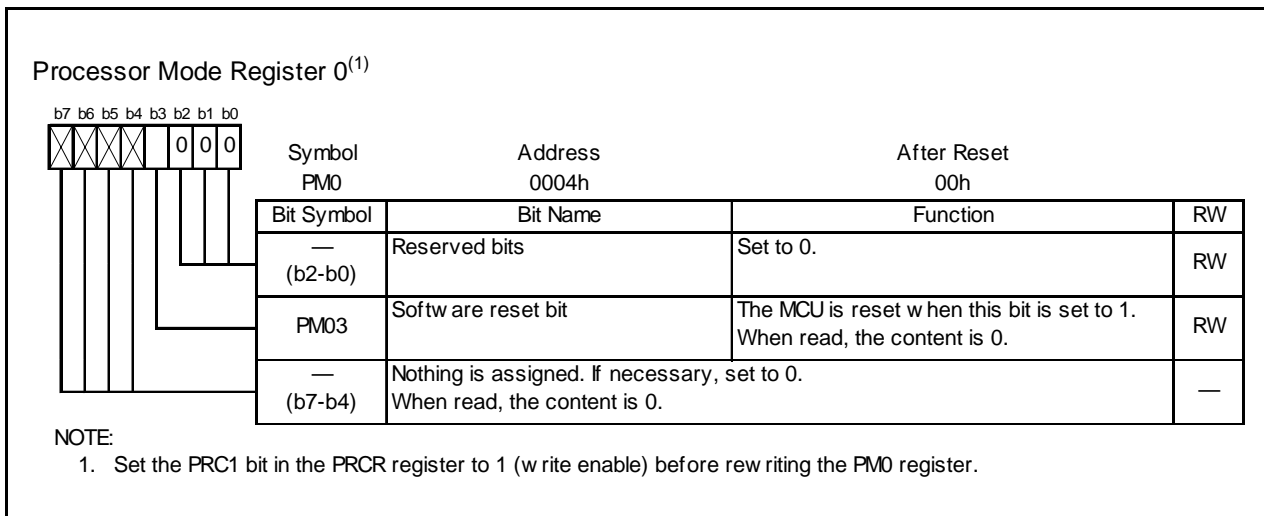

Figure 8.1 PM0 Register

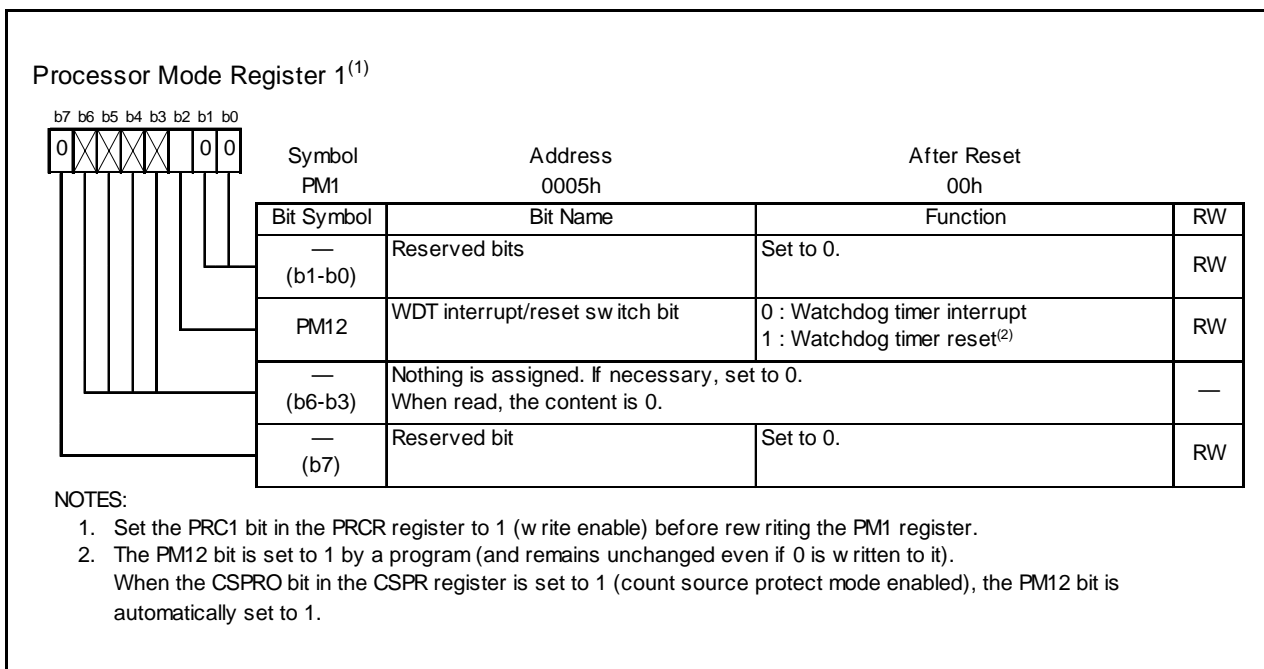

Figure 8.2 PM1 Register

9. Bus

The bus cycles differ when accessing ROM/RAM, and when accessing SFR.

Table 9.1 lists Bus Cycles by Access Space of the R8C/24 Group and Table 9.2 lists Bus Cycles by Access Space of the R8C/25 Group.

ROM/RAM and SFR are connected to the CPU by an 8-bit bus. When accessing in word (16-bit) units, these areas are accessed twice in 8-bit units.

Table 9.3 lists Access Units and Bus Operations.

Table 9.1 Bus Cycles by Access Space of the R8C/24 Group

Access Area	Bus Cycle
SFR	2 cycles of CPU clock
ROM/RAM	1 cycle of CPU clock

Table 9.2 Bus Cycles by Access Space of the R8C/25 Group

Access Area	Bus Cycle
SFR/Data flash	2 cycles of CPU clock
Program ROM/RAM	1 cycle of CPU clock

Table 9.3 Access Units and Bus Operations

Area	SFR, data flash	ROM (program ROM), RAM
Even address Byte access		
Odd address Byte access		
Even address Word access		
Odd address Word access		

However, only following SFRs are connected with the 16-bit bus:

Timer RD: registers TRDi (i = 0,1), TRDGRAi, TRDGRBi, TRDGRCi, and TRDGRDi

Therefore, they are accessed once in 16-bit units. The bus operation is the same as “Area: SFR, data flash, even address byte access” in Table 9.3 Access Units and Bus Operations, and 16-bit data is accessed at a time.

10. Clock Generation Circuit

The clock generation circuit has:

- XIN clock oscillation circuit
- XCIN clock oscillation circuit
- Low-speed on-chip oscillator (with oscillation stop detection function)
- High-speed on-chip oscillator

Table 10.1 lists Specifications of Clock Generation Circuit. Figure 10.1 shows a Clock Generation Circuit. Figures 10.2 to 10.8 show clock associated registers.

Table 10.1 Specifications of Clock Generation Circuit

Item	XIN Clock Oscillation Circuit	XCIN Clock Oscillation Circuit	On-Chip Oscillator	
			High-Speed On-Chip Oscillator	Low-Speed On-Chip Oscillator
Applications	<ul style="list-style-type: none"> • CPU clock source • Peripheral function clock source 	<ul style="list-style-type: none"> • CPU clock source • Timer RA and timer RE clock source 	<ul style="list-style-type: none"> • CPU clock source • Peripheral function clock source • CPU and peripheral function clock sources when XIN clock stops oscillating 	<ul style="list-style-type: none"> • CPU clock source • Peripheral function clock source • CPU and peripheral function clock sources when XIN clock stops oscillating
Clock frequency	0 to 20 MHz	32.768 kHz	Approx. 40 MHz ⁽⁴⁾	Approx. 125 kHz
Connectable oscillator	<ul style="list-style-type: none"> • Ceramic resonator • Crystal oscillator 	• Crystal oscillator	–	–
Oscillator connect pins	XIN, XOUT ⁽¹⁾	XCIN, XCOU ⁽²⁾	– ⁽¹⁾	– ⁽¹⁾
Oscillation stop, restart function	Usable	Usable	Usable	Usable
Oscillator status after reset	Stop	Stop	Stop	Oscillate
Others	Externally generated clock can be input ⁽³⁾	<ul style="list-style-type: none"> • Externally generated clock can be input • On-chip feedback resistor R_f (connected/not connected, selectable) 	–	–

NOTES:

1. These pins can be used as P4_6 or P4_7 when using the on-chip oscillator clock as the CPU clock while the XIN clock oscillation circuit is not used.
2. These pins can be used as P4_3 and P4_4 when using the XIN clock oscillation circuit and on-chip oscillator clock for a CPU clock while the XCIN clock oscillation circuit is not used.
3. Set the CM05 bit in the CM0 register to 1 (XIN clock stopped) and the CM13 bit in the CM1 register to 1 (XIN-XOUT pin) when an external clock is input.
4. The clock frequency is automatically set to up to 20 MHz by a divider when using the high-speed on-chip oscillator as the CPU clock source.

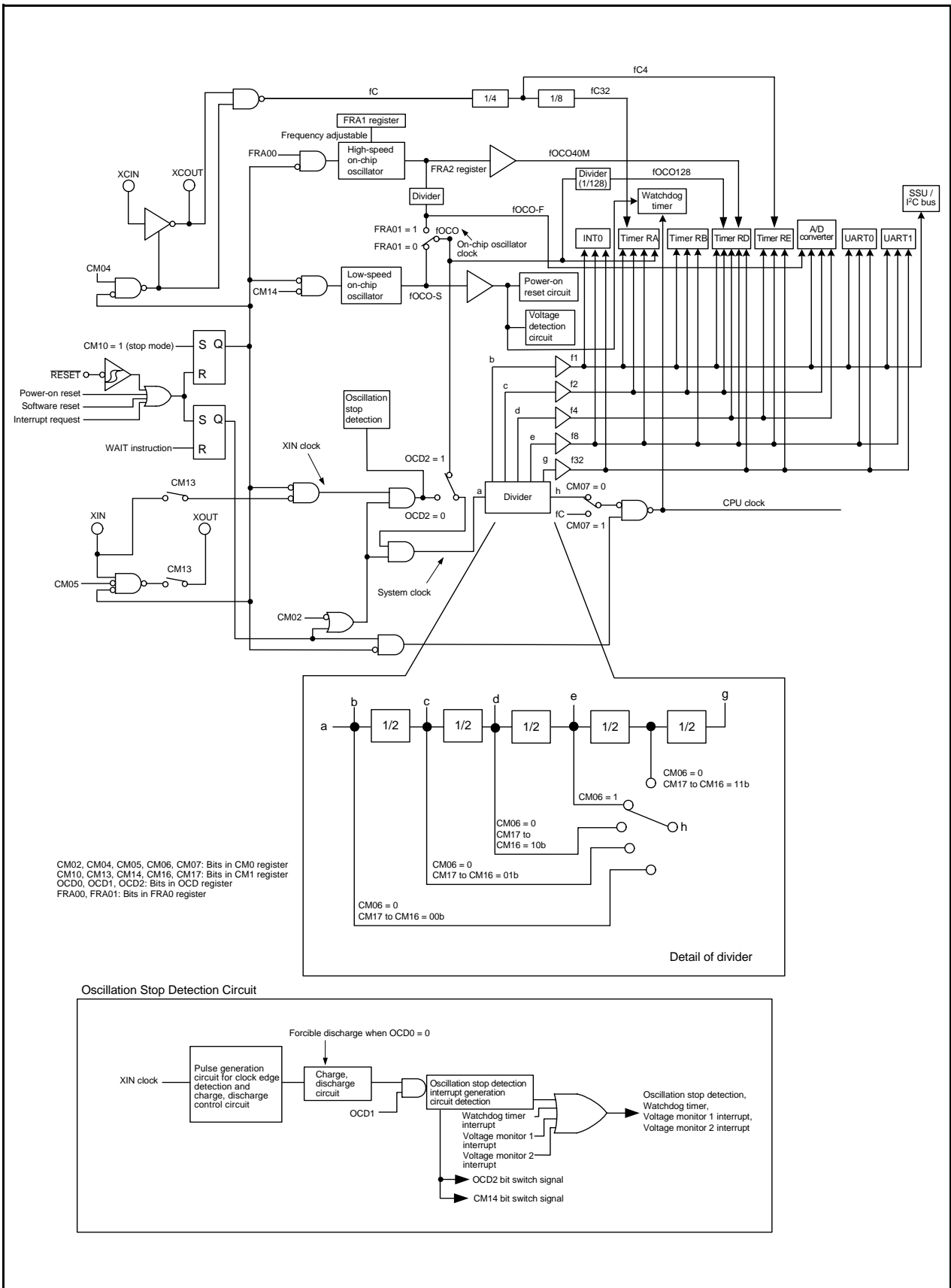

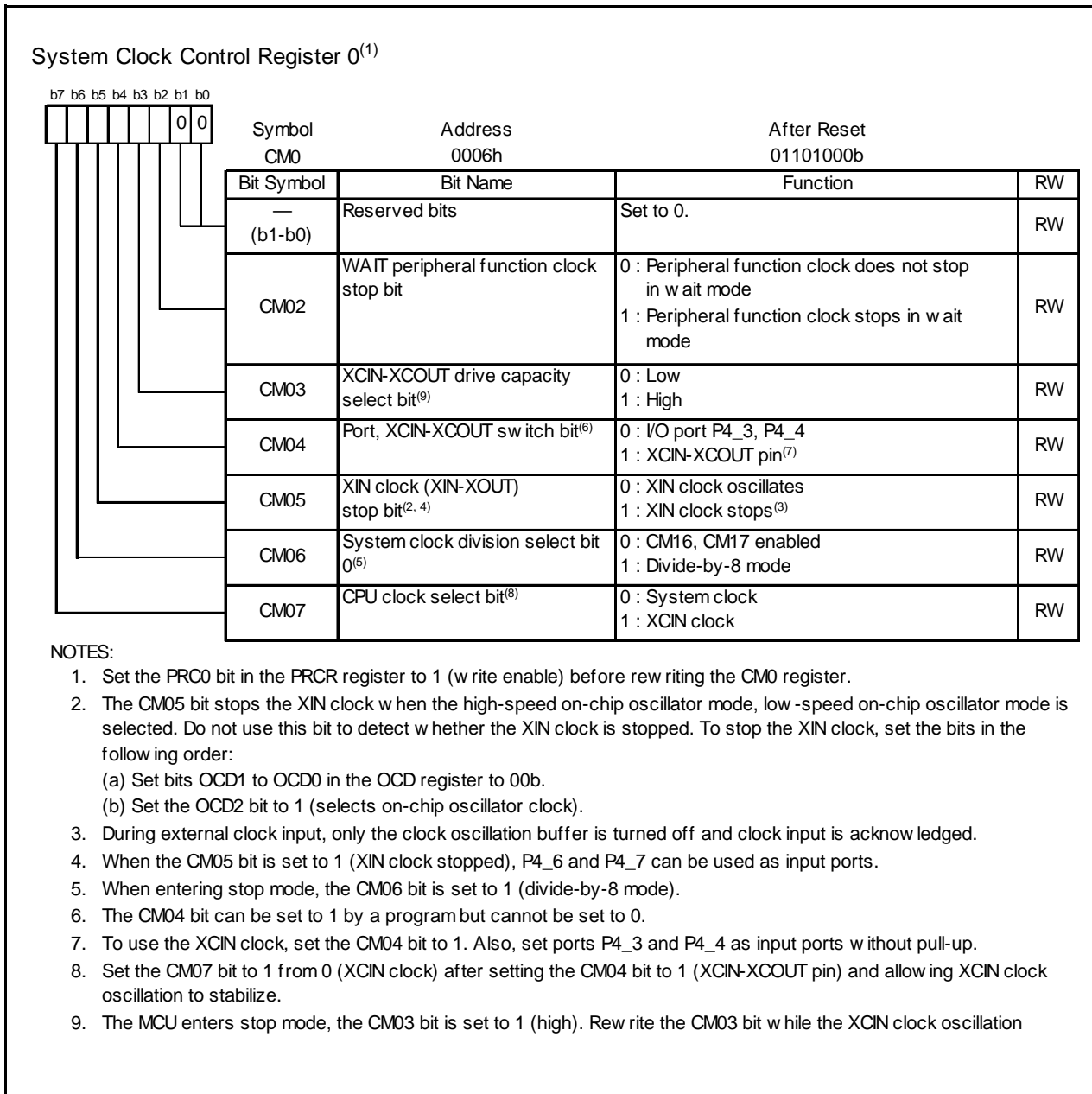

Figure 10.2 CM0 Register

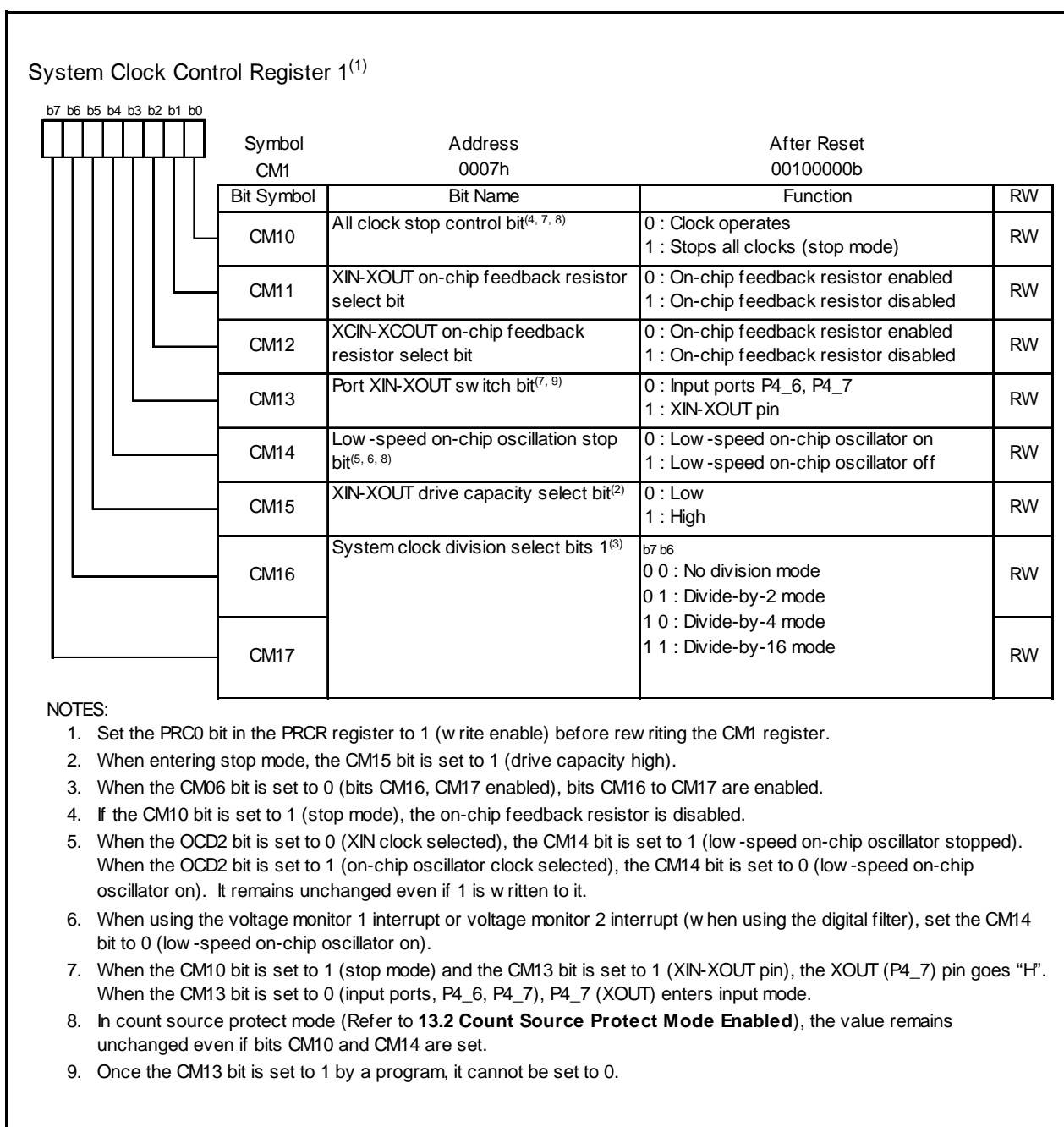

Figure 10.3 CM1 Register

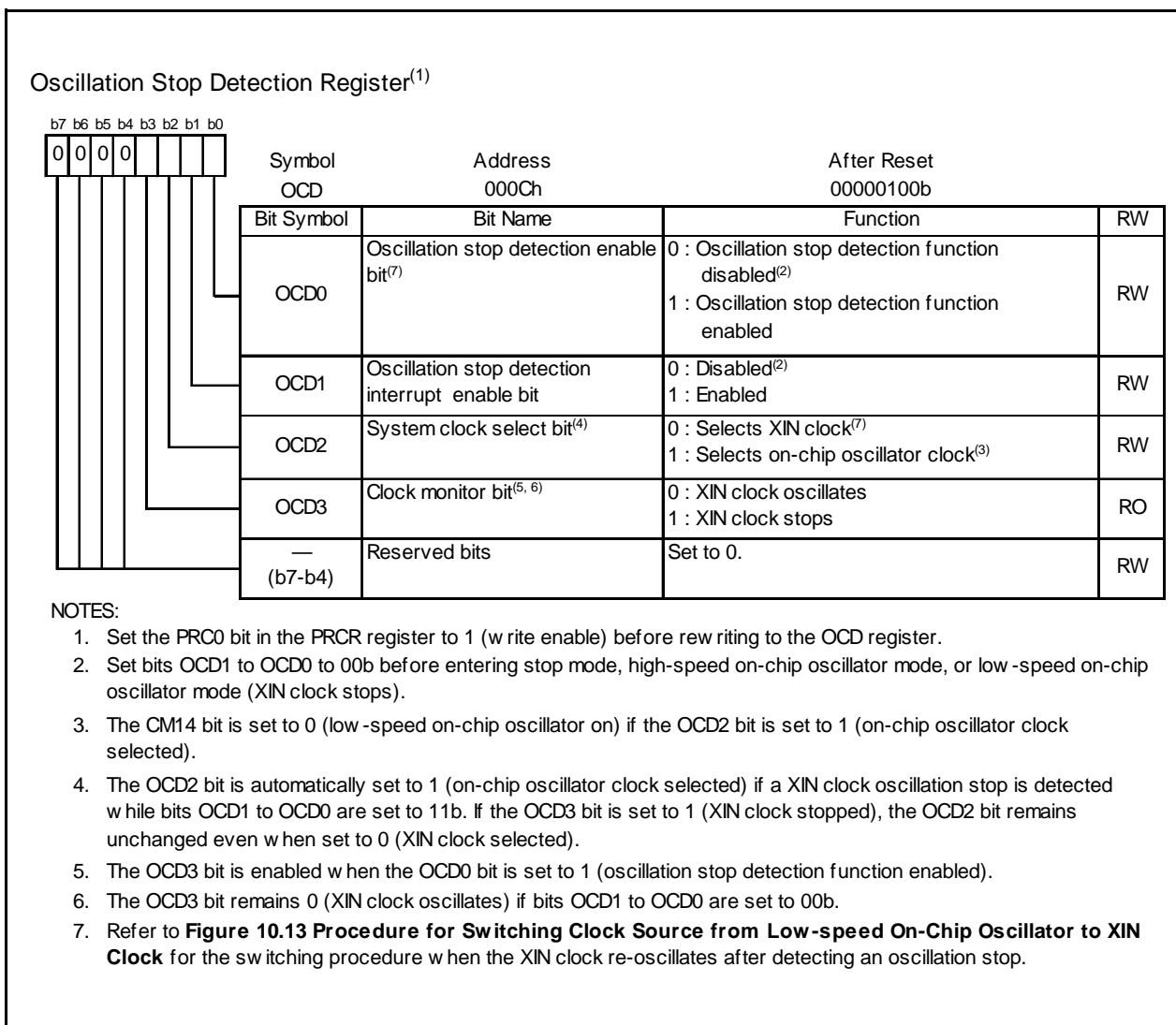

Figure 10.4 OCD Register

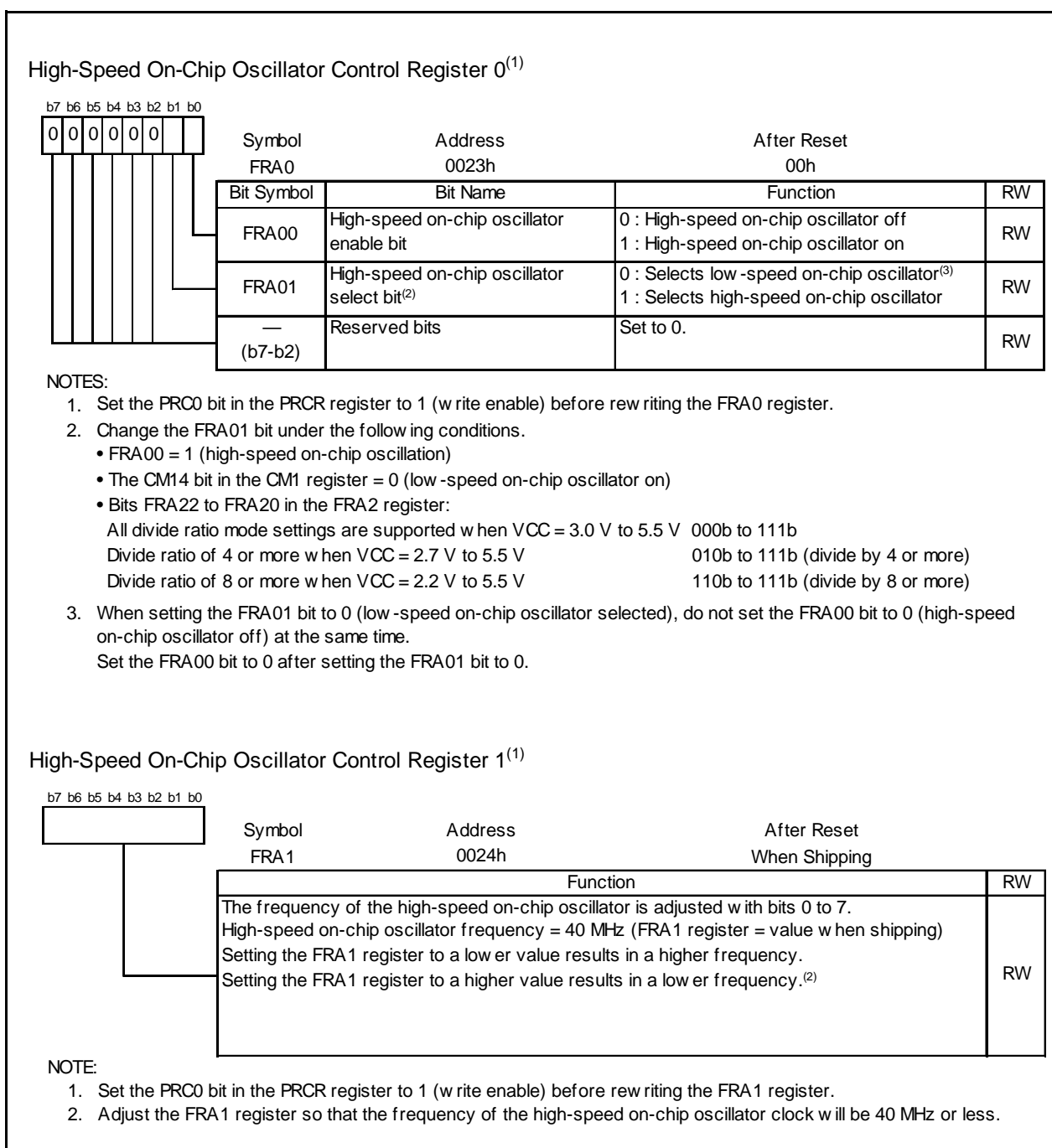

Figure 10.5 Registers FRA0 and FRA1

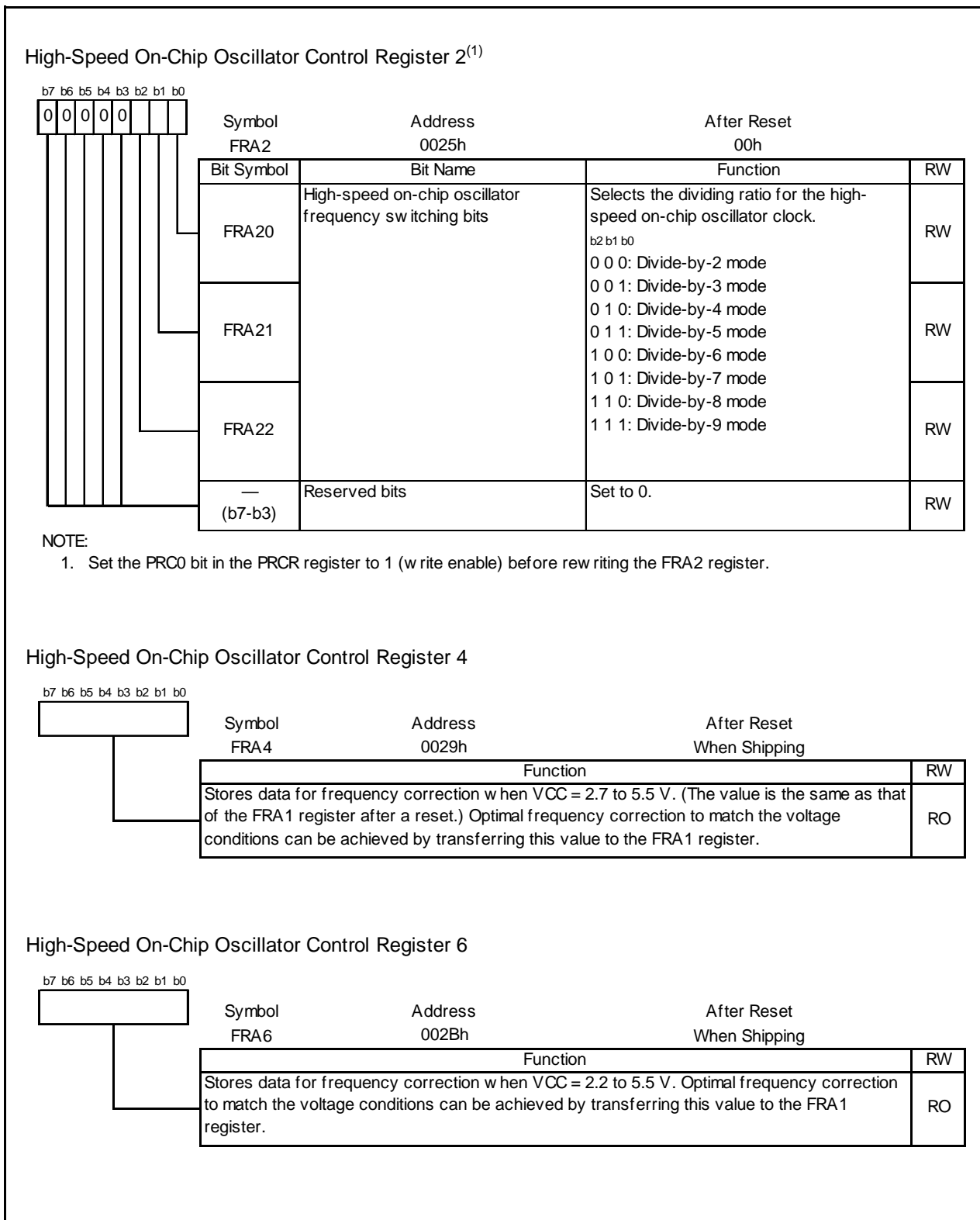
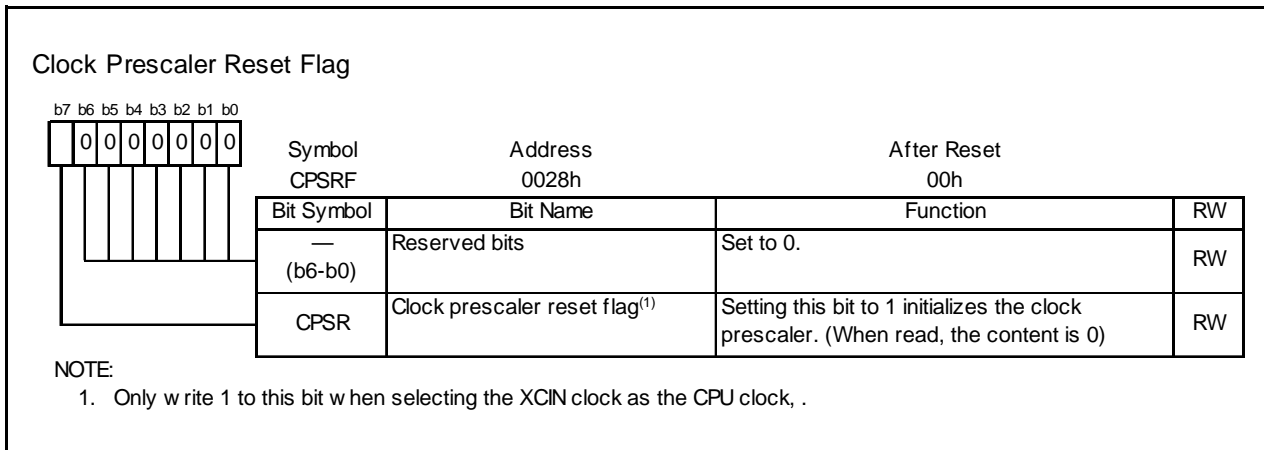
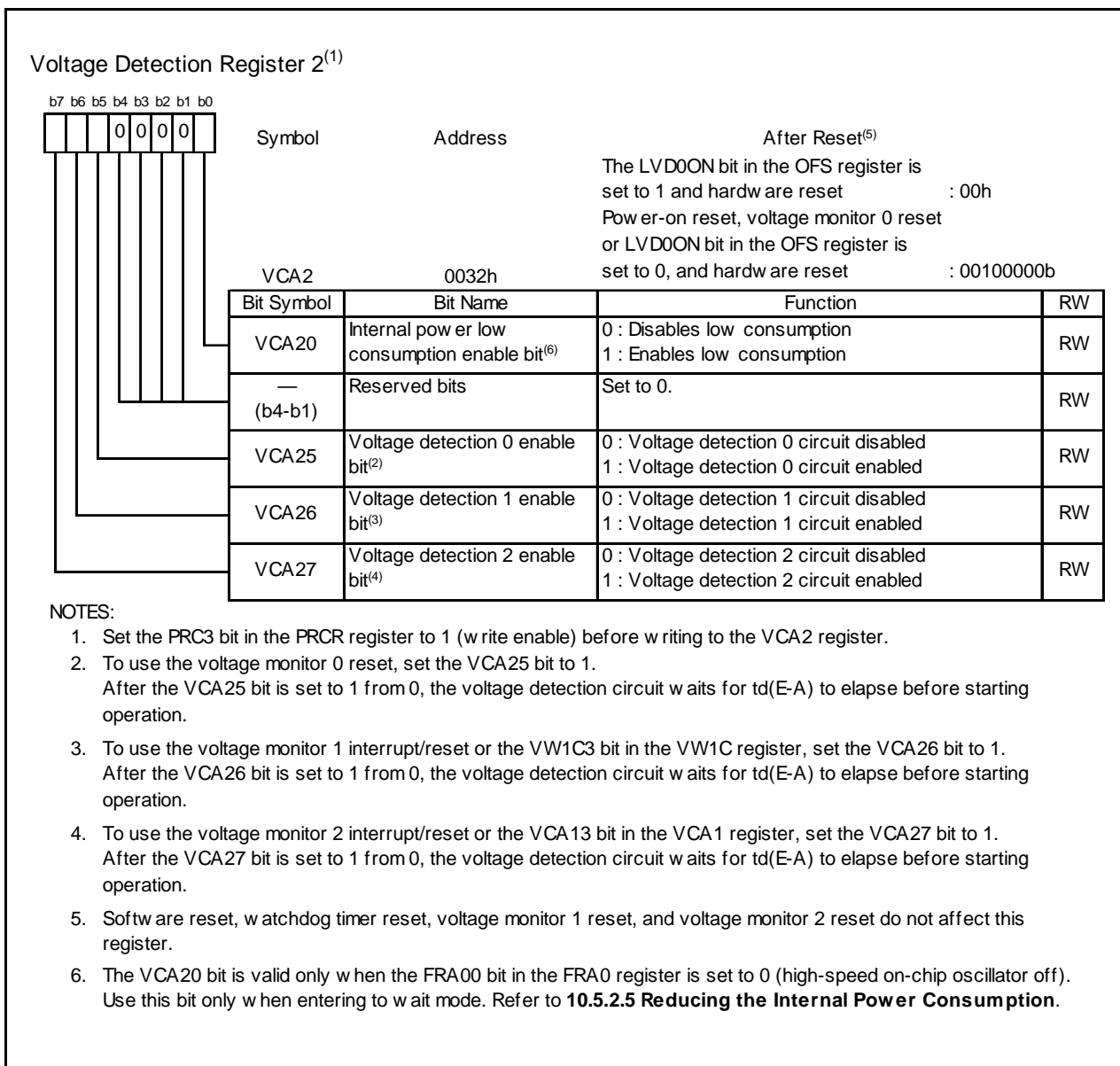

Figure 10.6 Registers FRA2, FRA4, and FRA6

**Figure 10.7 CPSRF Register****Figure 10.8 VCA2 Register**

The clocks generated by the clock generation circuits are described below.

10.1 XIN Clock

This clock is supplied by the XIN clock oscillation circuit. This clock is used as the clock source for the CPU and peripheral function clocks. The XIN clock oscillation circuit is configured by connecting a resonator between the XIN and XOUT pins. The XIN clock oscillation circuit includes an on-chip feedback resistor, which is disconnected from the oscillation circuit in stop mode in order to reduce the amount of power consumed by the chip. The XIN clock oscillation circuit may also be configured by feeding an externally generated clock to the XIN pin.

Figure 10.9 shows Examples of XIN Clock Connection Circuit.

In reset and after reset, the XIN clock stops.

The XIN clock starts oscillating when the CM05 bit in the CM0 register is set to 0 (XIN clock oscillates) after setting the CM13 bit in the CM1 register to 1 (XIN- XOUT pin).

To use the XIN clock for the CPU clock source, set the OCD2 bit in the OCD register to 0 (select XIN clock) after the XIN clock is oscillating stably.

The power consumption can be reduced by setting the CM05 bit in the CM0 register to 1 (XIN clock stops) if the OCD2 bit is set to 1 (select on-chip oscillator clock).

When an external clock is input to the XIN pin are input, the XIN clock does not stop if the CM05 bit is set to 1. If necessary, use an external circuit to stop the clock.

In stop mode, all clocks including the XIN clock stop. Refer to **10.5 Power Control** for details.

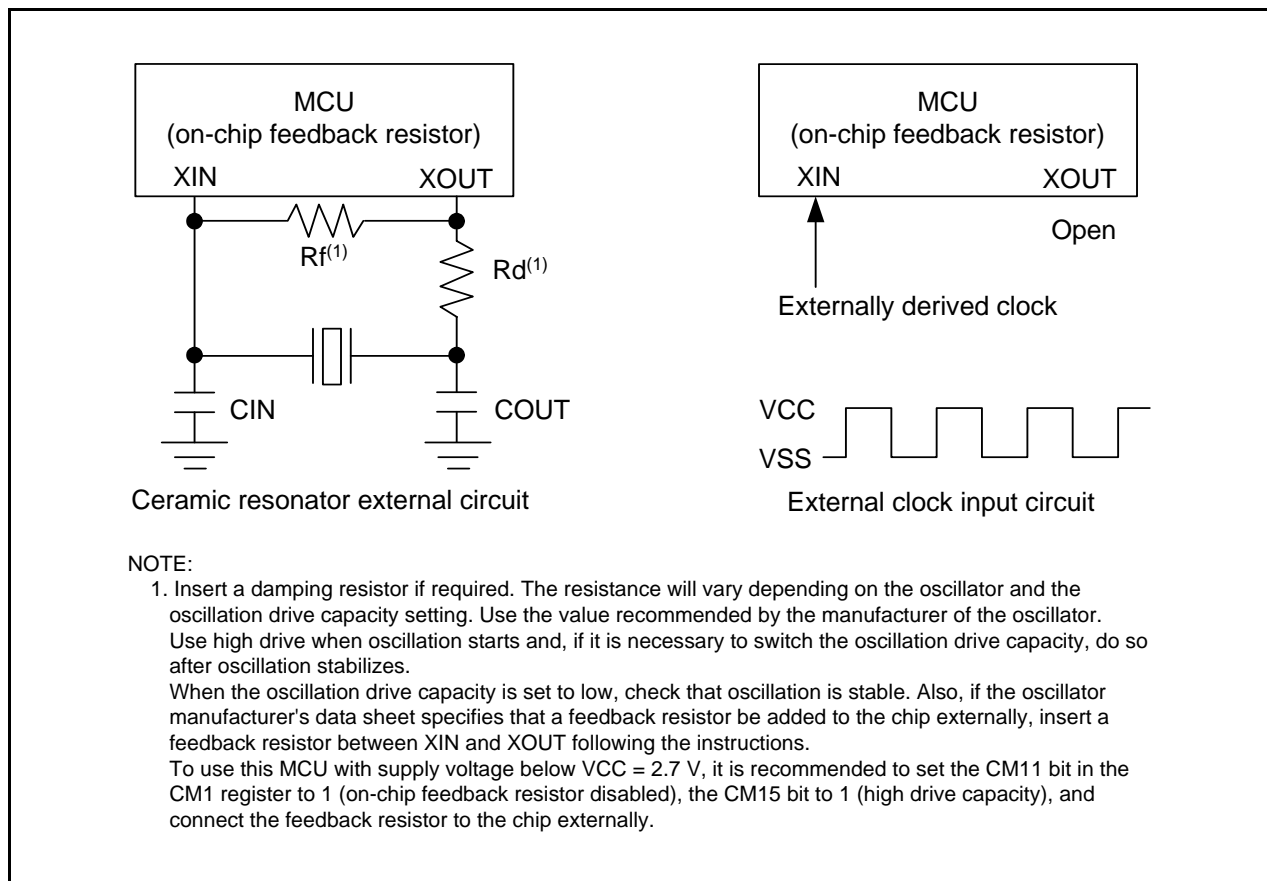

Figure 10.9 Examples of XIN Clock Connection Circuit

10.2 On-Chip Oscillator Clocks

These clocks are supplied by the on-chip oscillators (high-speed on-chip oscillator and a low-speed on-chip oscillator). The on-chip oscillator clock is selected by the FRA01 bit in the FRA0 register.

10.2.1 Low-Speed On-Chip Oscillator Clock

The clock generated by the low-speed on-chip oscillator is used as the clock source for the CPU clock, peripheral function clock, fOCO, and fOCO-S.

After reset, the on-chip oscillator clock generated by the low-speed on-chip oscillator divided by 8 is selected as the CPU clock.

If the XIN clock stops oscillating when bits OCD1 to OCD0 in the OCD register are set to 11b, the low-speed on-chip oscillator automatically starts operating, supplying the necessary clock for the MCU.

The frequency of the low-speed on-chip oscillator varies depending on the supply voltage and the operating ambient temperature. Application products must be designed with sufficient margin to allow for frequency changes.

10.2.2 High-Speed On-Chip Oscillator Clock

The clock generated by the high-speed on-chip oscillator is used as the clock source for the CPU clock, peripheral function clock, fOCO, fOCO-F, and fOCO40M.

To use the high-speed on-chip oscillator clock as the clock source for the CPU clock, peripheral clock, fOCO, and fOCO-F, set bits FRA20 to FRA22 in the FRA2 register as follows:

- All divide ratio mode settings are supported when VCC = 3.0 V to 5.5 V 000b to 111b
- Divide ratio of 4 or more when VCC = 2.7 V to 5.5 V 010b to 111b (divide by 4 or more)
- Divide ratio of 8 or more when VCC = 2.2 V to 5.5 V 110b to 111b (divide by 8 or more)

After reset, the on-chip oscillator clock generated by the high-speed on-chip oscillator stops. Oscillation is started by setting the FRA00 bit in the FRA0 register to 1 (high-speed on-chip oscillator on). The frequency can be adjusted by registers FRA1 and FRA2.

Furthermore, frequency correction data corresponding to the supply voltage ranges listed below is stored in registers FRA4 and FRA6. To use separate correction values to match these voltage ranges, transfer them from register FRA4 or FRA6 to the FRA1 register.

- FRA4 register: Stores data for frequency correction corresponding to VCC = 2.7 V to 5.5 V.
(The value is the same as that of the FRA1 register after a reset.)
- FRA6 register: Stores data for frequency correction corresponding to VCC = 2.2 V to 5.5 V.

Since there are differences in the amount of frequency adjustment among the bits in the FRA1 register, make adjustments by changing the settings of individual bits. Adjust the FRA1 register so that the frequency of the high-speed on-chip oscillator clock will be 40 MHz or less.

10.3 XCIN Clock

This clock is supplied by the XCIN clock oscillation circuit. This clock is used as the clock source for the CPU clock, timer RA, and timer RE. The XCIN clock oscillation circuit is configured by connecting a resonator between the XCIN and XCOOUT pins. The XCIN clock oscillation circuit includes an on-chip a feedback resistor, which is disconnected from the oscillation circuit in stop mode in order to reduce the amount of power consumed in the chip. The XCIN clock oscillation circuit may also be configured by feeding an externally generated clock to the XCIN pin.

Figure 10.10 shows Examples of XCIN Clock Connection Circuits.

During and after reset, the XCIN clock stops.

The XCIN clock starts oscillating when the CM04 bit in the CM0 register is set to 1 (XCIN-XCOOUT pin).

To use the XCIN clock for the CPU clock source, set the CM07 bit in the CM0 register to 1 (XCIN clock) after the XCIN clock is oscillating stably. To input an external clock to the XCIN pin, set the CM04 bit in the CM0 register to 1 (XCIN-XCOOUT pin) and leave the XCOOUT pin open.

This MCU has an on-chip feedback resistor and on-chip resistor disable/enable switching is possible by the CM12 bit in the CM1 register.

In stop mode, all clocks including the XCIN clock stop. Refer to **10.5 Power Control** for details.

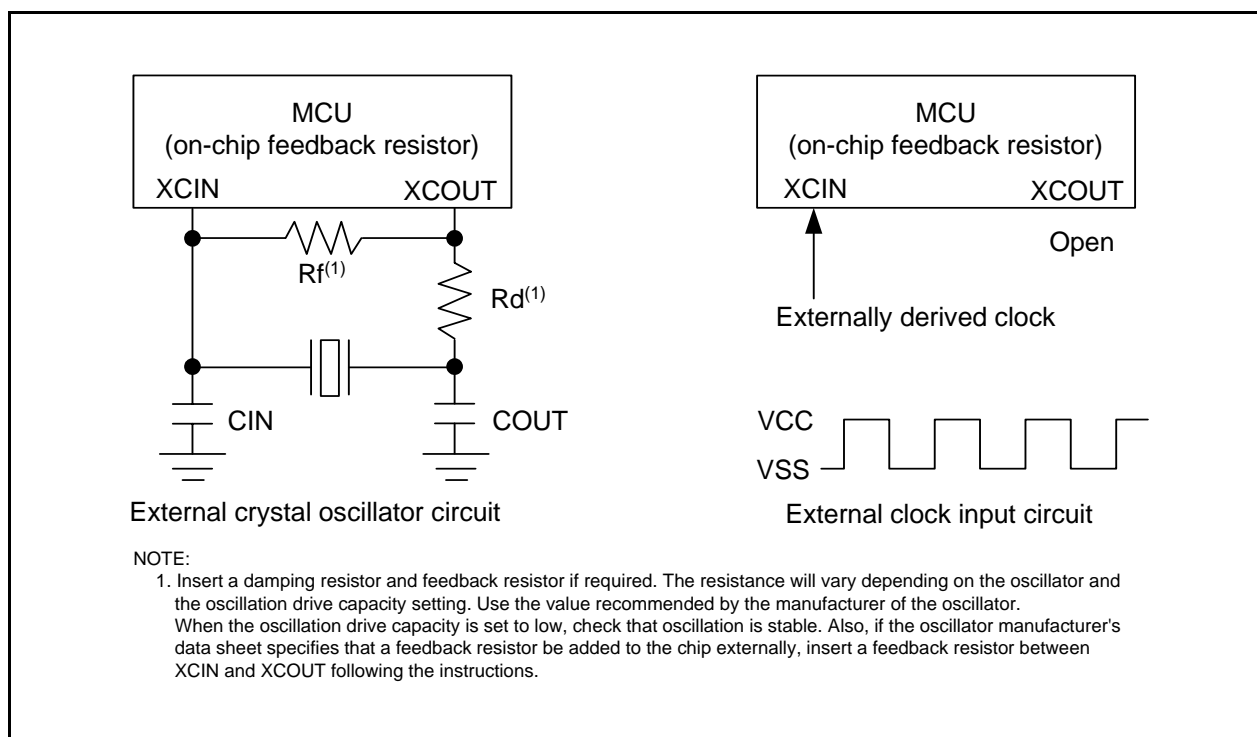

Figure 10.10 Examples of XCIN Clock Connection Circuits

10.4 CPU Clock and Peripheral Function Clock

There are a CPU clock to operate the CPU and a peripheral function clock to operate the peripheral functions. Refer to **Figure 10.1 Clock Generation Circuit**.

10.4.1 System Clock

The system clock is the clock source for the CPU and peripheral function clocks. Either the XIN clock or the on-chip oscillator clock can be selected.

10.4.2 CPU Clock

The CPU clock is an operating clock for the CPU and watchdog timer.

When the CM07 bit in the CM0 register is set to 0 (system clock), the system clock can be divided by 1 (no division), 2, 4, 8, or 16 to produce the CPU clock. Use the CM06 bit in the CM0 register and bits CM16 to CM17 in the CM1 register to select the value of the division.

When the CM07 bit in the CM0 register is set to 1 (XCIN clock), the XCIN clock is used for the CPU clock. Use the XCIN clock while the XCIN clock oscillation stabilizes.

After reset, the low-speed on-chip oscillator clock divided by 8 provides the CPU clock.

When entering stop mode from high-speed clock mode, the CM06 bit is set to 1 (divide-by-8 mode).

10.4.3 Peripheral Function Clock (f1, f2, f4, f8, and f32)

The peripheral function clock is the operating clock for the peripheral functions.

The clock f_i ($i = 1, 2, 4, 8, \text{ and } 32$) is generated by the system clock divided by i . The clock f_i is used for timers RA, RB, RD, and RE, the serial interface and the A/D converter.

When the WAIT instruction is executed after setting the CM02 bit in the CM0 register to 1 (peripheral function clock stops in wait mode), the clock f_i stop.

10.4.4 fOCO

fOCO is an operating clock for the peripheral functions.

fOCO runs at the same frequency as the on-chip oscillator clock and can be used as the source for timer RA.

When the WAIT instruction is executed, the clocks fOCO does not stop.

10.4.5 fOCO40M

fOCO40M is used as the count source for timer RD. fOCO40M is generated by the high-speed on-chip oscillator and supplied by setting the FRA00 bit to 1.

When the WAIT instruction is executed, the clock fOCO40M does not stop.

fOCO40M can be used with supply voltage $VCC = 3.0$ to 5.5 V.

10.4.6 fOCO-F

fOCO-F is used as the count source for the A/D converter. fOCO-F is generated by the high-speed on-chip oscillator and supplied by setting the FRA00 bit to 1.

When the WAIT instruction is executed, the clock fOCO-F does not stop.

10.4.7 fOCO-S

fOCO-S is an operating clock for the watchdog timer and voltage detection circuit. fOCO-S is supplied by setting the CM14 bit to 0 (low-speed on-chip oscillator on) and uses the clock generated by the low-speed on-chip oscillator. When the WAIT instruction is executed or in count source protect mode of the watchdog timer, fOCO-S does not stop.

10.4.8 fOCO128

fOCO128 is generated by fOCO divided by 128.

The clock fOCO128 is used for capture signal of timer RD (channel 0).

10.4.9 fC4 and fC32

The clock fC4 and fC32 are used for timer RA and timer RE.
Use fC4 and fC32 while the XCIN clock oscillation stabilizes.

10.5 Power Control

There are three power control modes. All modes other than wait mode and stop mode are referred to as standard operating mode.

10.5.1 Standard Operating Mode

Standard operating mode is further separated into four modes.

In standard operating mode, the CPU clock and the peripheral function clock are supplied to operate the CPU and the peripheral function clocks. Power consumption control is enabled by controlling the CPU clock frequency. The higher the CPU clock frequency, the more processing power increases. The lower the CPU clock frequency, the more power consumption decreases. When unnecessary oscillator circuits stop, power consumption is further reduced.

Before the clock sources for the CPU clock can be switched over, the new clock source needs to be oscillating and stable. If the new clock source is the XIN clock or XCIN clock, allow sufficient wait time in a program until oscillation is stabilized before exiting.

Table 10.2 Settings and Modes of Clock Associated Bits

Modes		OCD Register	CM1 Register			CM0 Register				FRA0 Register	
		OCD2	CM17, CM16	CM14	CM13	CM07	CM06	CM05	CM04	FRA01	FRA00
High-speed clock mode	No division	0	00b	–	1	0	0	0	–	–	–
	Divide-by-2	0	01b	–	1	0	0	0	–	–	–
	Divide-by-4	0	10b	–	1	0	0	0	–	–	–
	Divide-by-8	0	–	–	1	0	1	0	–	–	–
	Divide-by-16	0	11b	–	1	0	0	0	–	–	–
Low-speed clock mode	No division	–	–	–	–	1	–	–	1	–	–
High-speed on-chip oscillator mode	No division	1	00b	–	–	0	0	–	–	1	1
	Divide-by-2	1	01b	–	–	0	0	–	–	1	1
	Divide-by-4	1	10b	–	–	0	0	–	–	1	1
	Divide-by-8	1	–	–	–	0	1	–	–	1	1
	Divide-by-16	1	11b	–	–	0	0	–	–	1	1
Low-speed on-chip oscillator mode	No division	1	00b	0	–	0	0	–	–	0	–
	Divide-by-2	1	01b	0	–	0	0	–	–	0	–
	Divide-by-4	1	10b	0	–	0	0	–	–	0	–
	Divide-by-8	1	–	0	–	0	1	–	–	0	–
	Divide-by-16	1	11b	0	–	0	0	–	–	0	–

X: can be 0 or 1, no change in outcome

10.5.1.1 High-Speed Clock Mode

The XIN clock divided by 1 (no division), 2, 4, 8, or 16 provides the CPU clock. Set the CM06 bit to 1 (divide-by-8 mode) when transiting to high-speed on-chip oscillator mode, low-speed on-chip oscillator mode. If the CM14 bit is set to 0 (low-speed on-chip oscillator on) or the FRA00 bit in the FRA0 register is set to 1 (high-speed on-chip oscillator on), fOCO can be used as timer RA. When the FRA00 bit is set to 1, fOCO40M can be used as timer RD. When the CM14 bit is set to 0 (low-speed on-chip oscillator on), fOCO-S can be used for the watchdog timer and voltage detection circuit.

10.5.1.2 Low-Speed Clock Mode

The XCIN clock divided by 1 (no division) provides the CPU clock.

In this mode, stopping the XIN clock and high-speed on-chip oscillator, and setting the FMR47 bit in the FMR4 register to 1 (flash memory low consumption current read mode enabled) enables low consumption operation.

When the FRA00 bit is set to 1, fOCO40M can be used as timer RD. When the CM14 bit is set to 0 (low-speed on-chip oscillator on), fOCO-S can be used for the watchdog timer and voltage detection circuit.

To enter wait mode from low-speed clock mode, setting the VCA20 bit in the VCA2 register to 1 (internal power low consumption enabled) enables lower consumption current in wait mode.

10.5.1.3 High-Speed On-Chip Oscillator Mode

The high-speed on-chip oscillator is used as the on-chip oscillator clock when the FRA00 bit in the FRA0 register is set to 1 (high-speed on-chip oscillator on) and the FRA01 bit in the FRA0 register is set to 1. The on-chip oscillator divided by 1 (no division), 2, 4, 8, or 16 provides the CPU clock. Set the CM06 bit to 1 (divide-by-8 mode) when transiting to high-speed clock mode. If the FRA00 bit is set to 1, fOCO40M can be used as timer RD. When the CM14 bit is set to 0 (low-speed on-chip oscillator on), fOCO-S can be used for the watchdog timer and voltage detection circuit.

10.5.1.4 Low-Speed On-Chip Oscillator Mode

If the CM14 bit in the CM1 register is set to 0 (low-speed on-chip oscillator on) or the FRA01 bit in the FRA0 register is set to 0, the low-speed on-chip oscillator provides the on-chip oscillator clock.

The on-chip oscillator clock divided by 1 (no division), 2, 4, 8 or 16 provides the CPU clock. The on-chip oscillator clock is also the clock source for the peripheral function clocks. Set the CM06 bit to 1 (divide-by-8 mode) when transiting to high-speed clock mode. When the FRA00 bit is set to 1, fOCO40M can be used as timer RD. When the CM14 bit is set to 0 (low-speed on-chip oscillator on), fOCO-S can be used as the watchdog timer and voltage detection circuit.

In this mode, stopping the XIN clock and high-speed on-chip oscillator, and setting the FMR47 bit in the FMR4 register to 1 (flash memory low consumption current read mode enabled) enables low consumption operation.

To enter wait mode from low-speed clock mode, setting the VCA20 bit in the VCA2 register to 1 (internal power low consumption enabled) enables lower consumption current in wait mode.

10.5.2 Wait Mode

Since the CPU clock stops in wait mode, the CPU, which operates using the CPU clock, and the watchdog timer, when count source protection mode is disabled, stop. The XIN clock, XCIN clock, and on-chip oscillator clock do not stop and the peripheral functions using these clocks continue operating.

10.5.2.1 Peripheral Function Clock Stop Function

If the CM02 bit is set to 1 (peripheral function clock stops in wait mode), the f1, f2, f4, f8, and f32 clocks stop in wait mode. This reduces power consumption.

10.5.2.2 Entering Wait Mode

The MCU enters wait mode when the WAIT instruction is executed.

When the OCD2 bit in the OCD register is set to 1 (on-chip oscillator selected as system clock), set the OCD1 bit in the OCD register to 0 (oscillation stop detection interrupt disabled) before executing the WAIT instruction.

If the MCU enters wait mode while the OCD1 bit is set to 1 (oscillation stop detection interrupt enabled), current consumption is not reduced because the CPU clock does not stop.

10.5.2.3 Pin Status in Wait Mode

The I/O port is the status before wait mode was entered is maintained.

10.5.2.4 Exiting Wait Mode

The MCU exits wait mode by a reset or a peripheral function interrupt.

The peripheral function interrupts are affected by the CM02 bit. When the CM02 bit is set to 0 (peripheral function clock does not stop in wait mode), all peripheral function interrupts can be used to exit wait mode. When the CM02 bit is set to 1 (peripheral function clock stops in wait mode), the peripheral functions using the peripheral function clock stop operating and the peripheral functions operated by external signals or on-chip oscillator clock can be used to exit wait mode.

Table 10.3 lists Interrupts to Exit Wait Mode and Usage Conditions.

Table 10.3 Interrupts to Exit Wait Mode and Usage Conditions

Interrupt	CM02 = 0	CM02 = 1
Serial interface interrupt	Usable when operating with internal or external clock	Usable when operating with external clock
Clock synchronous serial I/O with chip select interrupt / I ² C bus interface interrupt	Usable in all modes	(Do not use)
Key input interrupt	Usable	Usable
A/D conversion interrupt	Usable in one-shot mode	(Do not use)
Timer RA interrupt	Usable in all modes	Can be used if there is no filter in event counter mode. Usable by selecting fOCO or fC32 as count source.
Timer RB interrupt	Usable in all modes	(Do not use)
Timer RD interrupt	Usable in all modes	Usable by selecting fOCO40M as count source
Timer RE interrupt	Usable in all modes	Usable when operating in real time clock mode
$\overline{\text{INT}}$ interrupt	Usable	Usable ($\overline{\text{INT0}}$ to $\overline{\text{INT3}}$ can be used if there is no filter.)
Voltage monitor 1 interrupt	Usable	Usable
Voltage monitor 2 interrupt	Usable	Usable
Oscillation stop detection interrupt	Usable	(Do not use)
Watchdog timer interrupt	Usable in count source protect mode	Usable in count source protect mode

Figure 10.11 shows the Time from Wait Mode to Interrupt Routine Execution.

When using a peripheral function interrupt to exit wait mode, set up the following before executing the WAIT instruction.

- (1) Set the interrupt priority level in bits ILVL2 to ILVL0 in the interrupt control registers of the peripheral function interrupts to be used for exiting wait mode. Set bits ILVL2 to ILVL0 of the peripheral function interrupts that are not to be used for exiting wait mode to 000b (interrupt disabled).
- (2) Set the I flag to 1.
- (3) Operate the peripheral function to be used for exiting wait mode.

When exiting by a peripheral function interrupt, the time (number of cycles) between interrupt request generation and interrupt routine execution is determined by the settings of the FMSTP bit in the FMR0 register and the CM07 bit in the CM0 register, as described in Figure 10.11.

The CPU clock, when exiting wait mode by a peripheral function interrupt, is the same clock as the CPU clock when the WAIT instruction is executed.

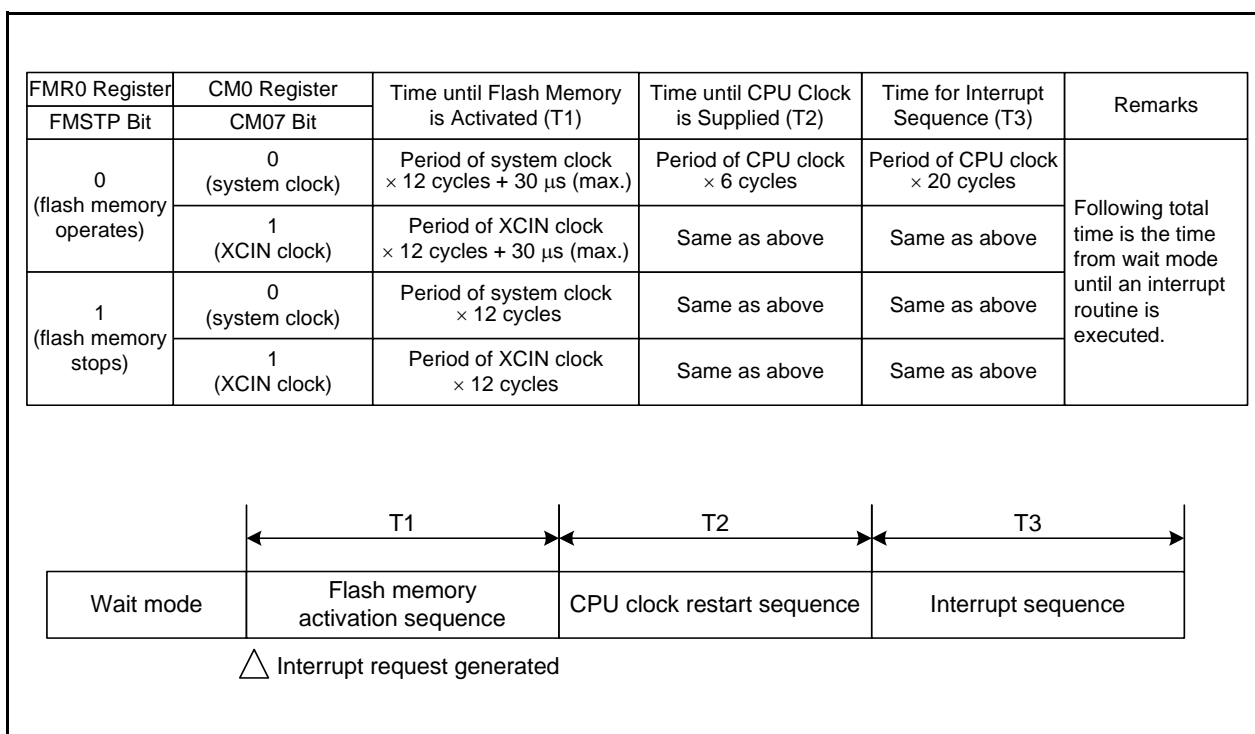

Figure 10.11 Time from Wait Mode to Interrupt Routine Execution

10.5.2.5 Reducing Internal Power Consumption

Internal power consumption can be reduced by using low-speed clock mode or low-speed on-chip oscillator mode. Figure 10.12 shows the Procedure for Enabling Reduced Internal Power Consumption Using VCA20 bit.

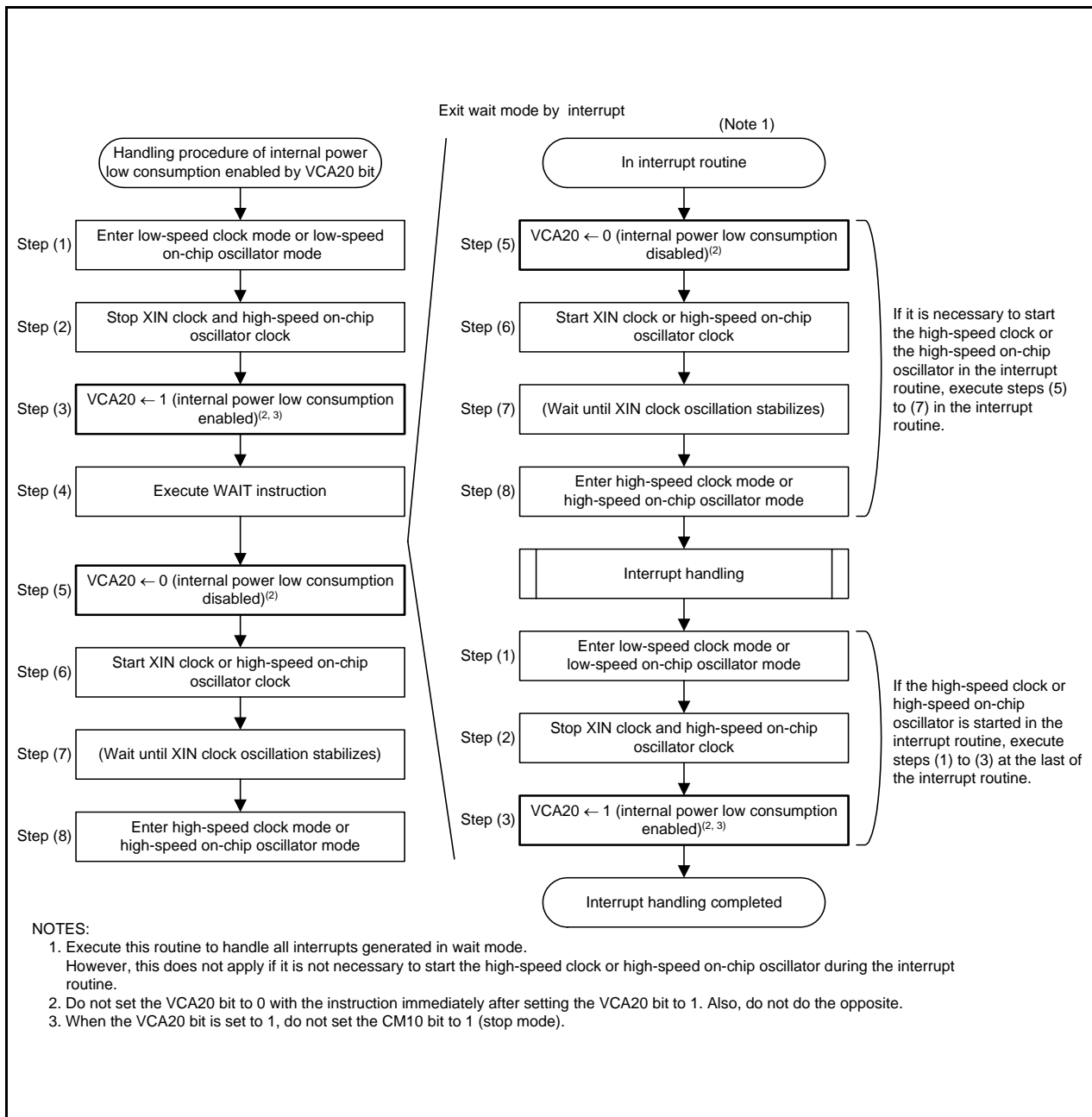

Figure 10.12 Procedure for Enabling Reduced Internal Power Consumption Using VCA20 bit

10.5.3 Stop Mode

Since the oscillator circuits stop in stop mode, the CPU clock and peripheral function clock stop and the CPU and peripheral functions that use these clocks stop operating. The least power required to operate the MCU is in stop mode. If the voltage applied to the VCC pin is V_{RAM} or more, the contents of internal RAM is maintained.

The peripheral functions clocked by external signals continue operating.

Table 10.4 lists Interrupts to Exit Stop Mode and Usage Conditions.

Table 10.4 Interrupts to Exit Stop Mode and Usage Conditions

Interrupt	Usage Conditions
Key input interrupt	–
$\overline{\text{INT0}}$ to $\overline{\text{INT3}}$ interrupt	Can be used if there is no filter
Timer RA interrupt	Can be used if there is no filter when external pulse is counted in event counter mode
Serial interface interrupt	When external clock is selected
Voltage monitor 1 interrupt	Usable in digital filter disabled mode (VW1C1 bit in VW1C register is set to 1)
Voltage monitor 2 interrupt	Usable in digital filter disabled mode (VW2C1 bit in VW2C register is set to 1)

10.5.3.1 Entering Stop Mode

The MCU enters stop mode when the CM10 bit in the CM1 register is set to 1 (all clocks stop). At the same time, the CM06 bit in the CM0 register is set to 1 (divide-by-8 mode) and the CM15 bit in the CM1 register is set to 1 (XIN clock oscillator circuit drive capacity high).

When using stop mode, set bits OCD1 to OCD0 to 00b before entering stop mode.

10.5.3.2 Pin Status in Stop Mode

The status before wait mode was entered is maintained.

However, when the CM13 bit in the CM1 register is set to 1 (XIN-XOUT pins), the XOUT(P4_7) pin is held "H". When the CM13 bit is set to 0 (input ports P4_6 and P4_7), the P4_7(XOUT pin) is held in input status.

10.5.3.3 Exiting Stop Mode

The MCU exits stop mode by a reset or peripheral function interrupt.

Figure 10.13 shows the Time from Stop Mode to Interrupt Routine Execution.

When using a peripheral function interrupt to exit stop mode, set up the following before setting the CM10 bit to 1.

- (1) Set the interrupt priority level in bits ILVL2 to ILVL0 of the peripheral function interrupts to be used for exiting stop mode. Set bits ILVL2 to ILVL0 of the peripheral function interrupts that are not to be used for exiting stop mode to 000b (interrupt disabled).
- (2) Set the I flag to 1.
- (3) Operates the peripheral function to be used for exiting stop mode.

When exiting by a peripheral function interrupt, the interrupt sequence is executed when an interrupt request is generated and the CPU clock supply is started.

If the clock used immediately before stop mode is a system clock and stop mode is exited by a peripheral function interrupt, the CPU clock becomes the previous system clock divided by 8.

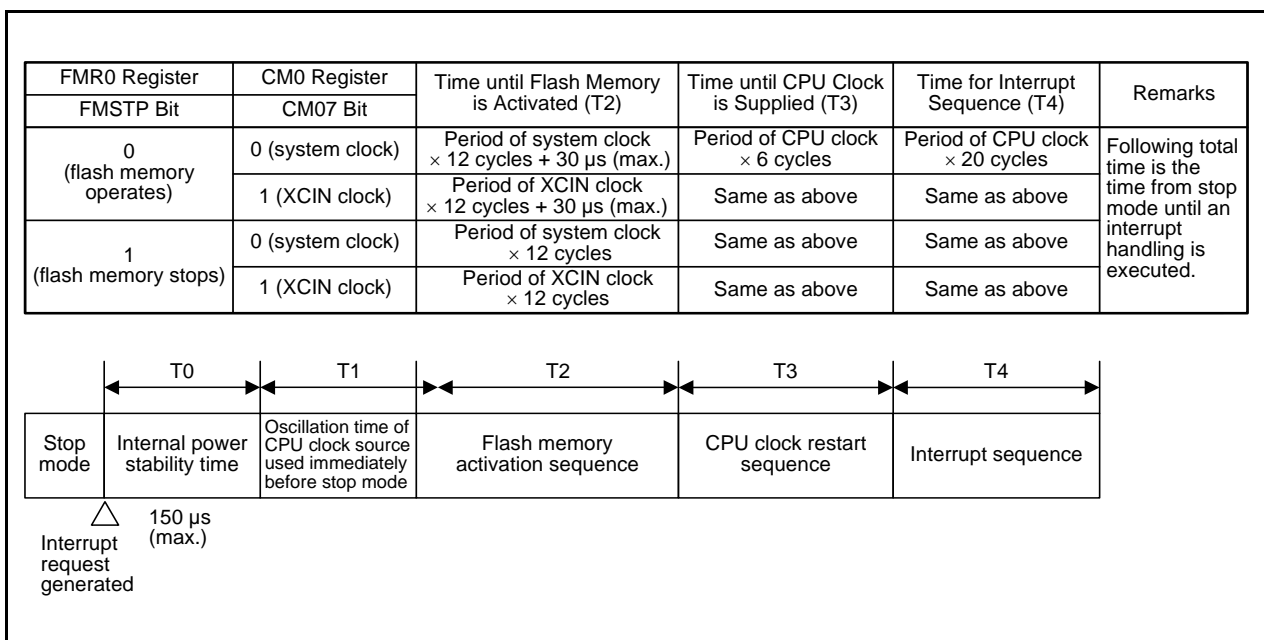

Figure 10.13 Time from Stop Mode to Interrupt Routine Execution

Figure 10.14 shows the State Transitions in Power Control Mode.

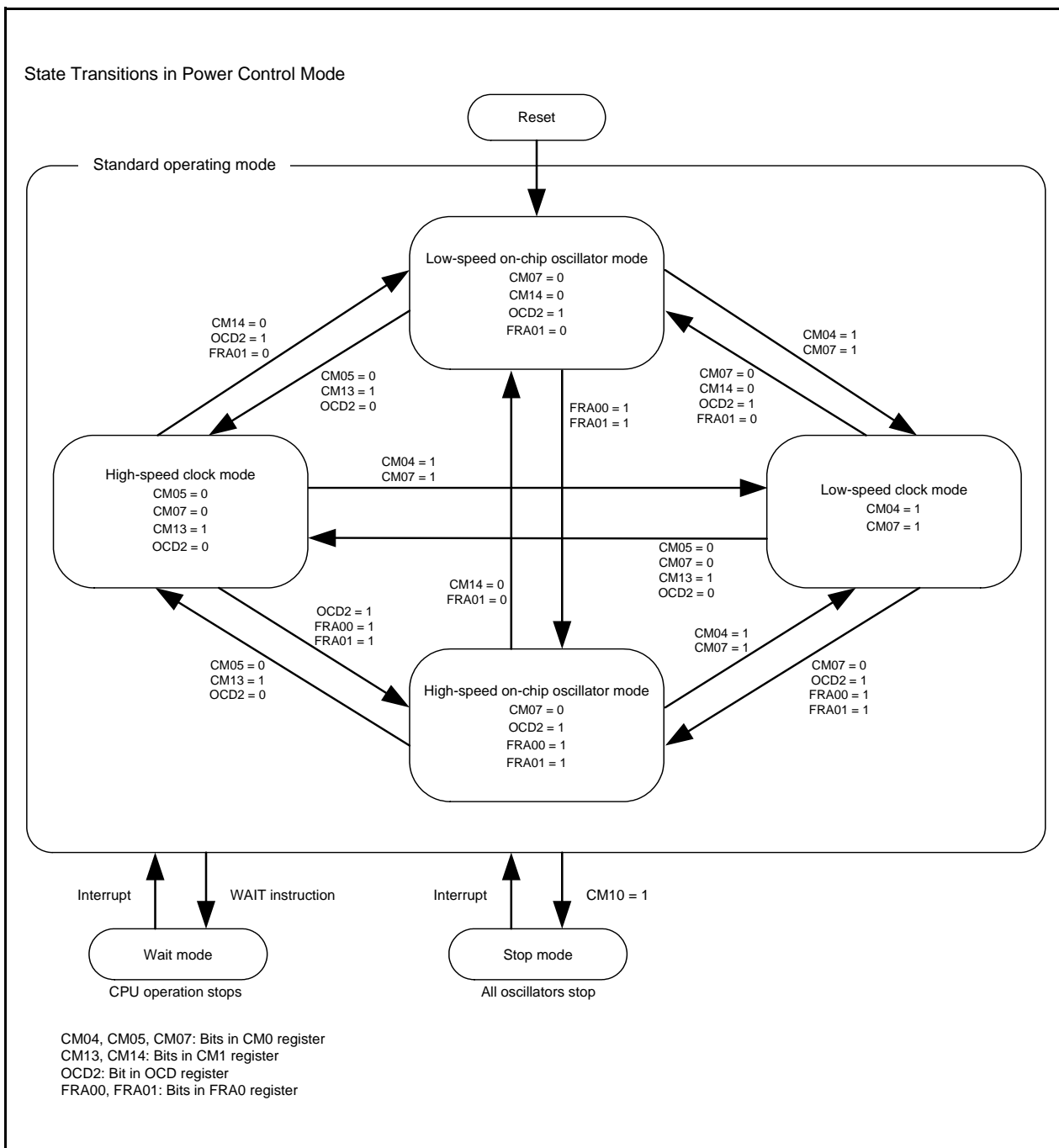

Figure 10.14 State Transitions in Power Control Mode

10.6 Oscillation Stop Detection Function

The oscillation stop detection function detects the stop of the XIN clock oscillating circuit. The oscillation stop detection function can be enabled and disabled by the OCD0 bit in the OCD register.

Table 10.5 lists the Specifications of Oscillation Stop Detection Function.

When the XIN clock is the CPU clock source and bits OCD1 to OCD0 are set to 11b, the system is placed in the following state if the XIN clock stops.

- OCD2 bit in OCD register = 1 (on-chip oscillator clock selected)
- OCD3 bit in OCD register = 1 (XIN clock stops)
- CM14 bit in CM1 register = 0 (low-speed on-chip oscillator oscillates)
- Oscillation stop detection interrupt request is generated.

Table 10.5 Specifications of Oscillation Stop Detection Function

Item	Specification
Oscillation stop detection clock and frequency bandwidth	$f(\text{XIN}) \geq 2 \text{ MHz}$
Enabled condition for oscillation stop detection function	Set bits OCD1 to OCD0 to 11b
Operation at oscillation stop detection	Oscillation stop detection interrupt is generated

10.6.1 How to Use Oscillation Stop Detection Function

- The oscillation stop detection interrupt shares a vector with the voltage monitor 1 interrupt, the voltage monitor 2 interrupt, and the watchdog timer interrupt. When using the oscillation stop detection interrupt and watchdog timer interrupt, the interrupt source needs to be determined.
Table 10.6 lists Determining Interrupt Source for Oscillation Stop Detection, Watchdog Timer, Voltage Monitor 1, and Voltage Monitor 2 Interrupts. Figure 10.16 shows an Example of Determining Interrupt Source for Oscillation Stop Detection, Watchdog Timer, Voltage Monitor 1, or Voltage Monitor 2 Interrupt.
- When the XIN clock restarts after oscillation stop, switch the XIN clock to the clock source of the CPU clock and peripheral functions by a program.
Figure 10.15 shows the Procedure for Switching Clock Source from Low-Speed On-Chip Oscillator to XIN Clock.
- To enter wait mode while using the oscillation stop detection function, set the CM02 bit to 0 (peripheral function clock does not stop in wait mode).
- Since the oscillation stop detection function is a function for cases where the XIN clock is stopped by an external cause, set bits OCD1 to OCD0 to 00b when the XIN clock stops or is started by a program, (stop mode is selected or the CM05 bit is changed).
- This function cannot be used when the XIN clock frequency is 2 MHz or below. In this case, set bits OCD1 to OCD0 to 00b.
- To use the low-speed on-chip oscillator clock for the CPU clock and clock sources of peripheral functions after detecting the oscillation stop, set the FRA01 bit in the FRA0 register to 0 (low-speed on-chip oscillator selected) and bits OCD1 to OCD0 to 11b.
To use the high-speed on-chip oscillator clock for the CPU clock and clock sources of peripheral functions after detecting the oscillation stop, set the FRA01 bit to 1 (high-speed on-chip oscillator selected) and bits OCD1 to OCD0 to 11b.

Table 10.6 Determining Interrupt Source for Oscillation Stop Detection, Watchdog Timer, Voltage Monitor 1, and Voltage Monitor 2 Interrupts

Generated Interrupt Source	Bit Showing Interrupt Cause
Oscillation stop detection ((a) or (b))	(a) OCD3 bit in OCD register = 1
	(b) OCD1 to OCD0 bits in OCD register = 11b and OCD2 bit = 1
Watchdog timer	VW2C3 bit in VW2C register = 1
Voltage monitor 1	VW1C2 bit in VW1C register = 1
Voltage monitor 2	VW2C2 bit in VW2C register = 1

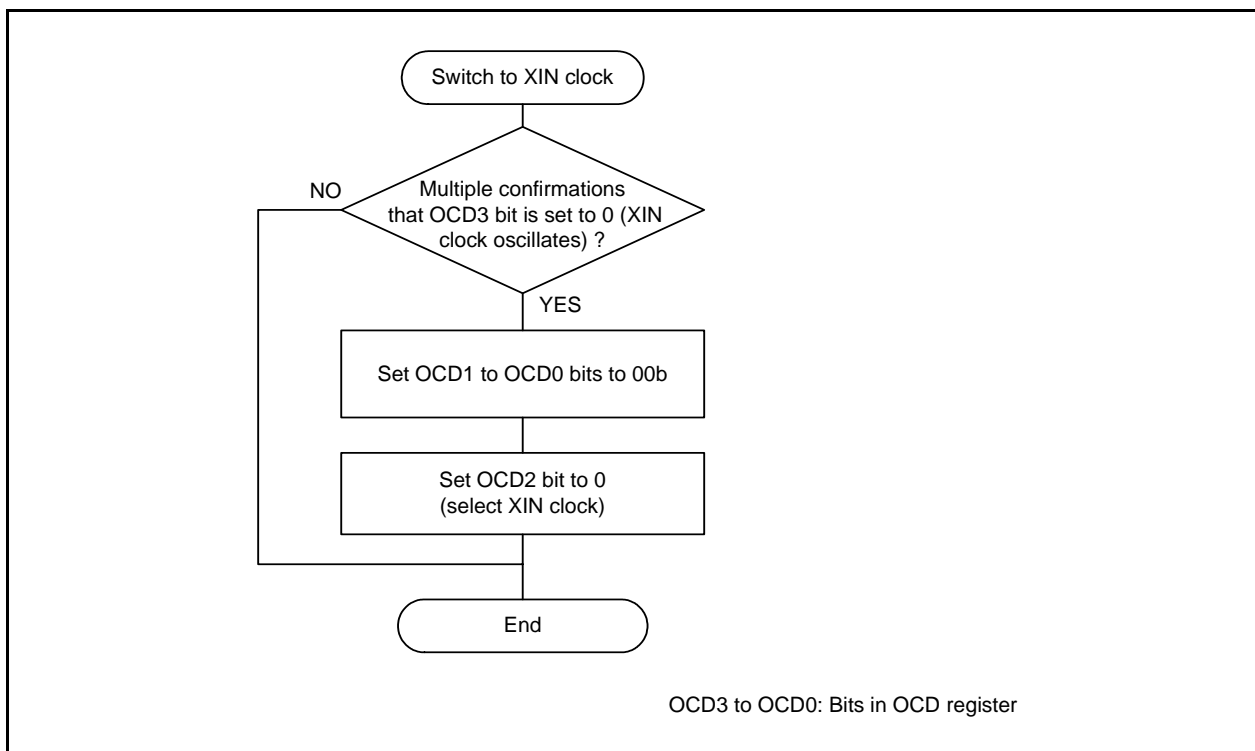
**Figure 10.15 Procedure for Switching Clock Source from Low-Speed On-Chip Oscillator to XIN Clock**

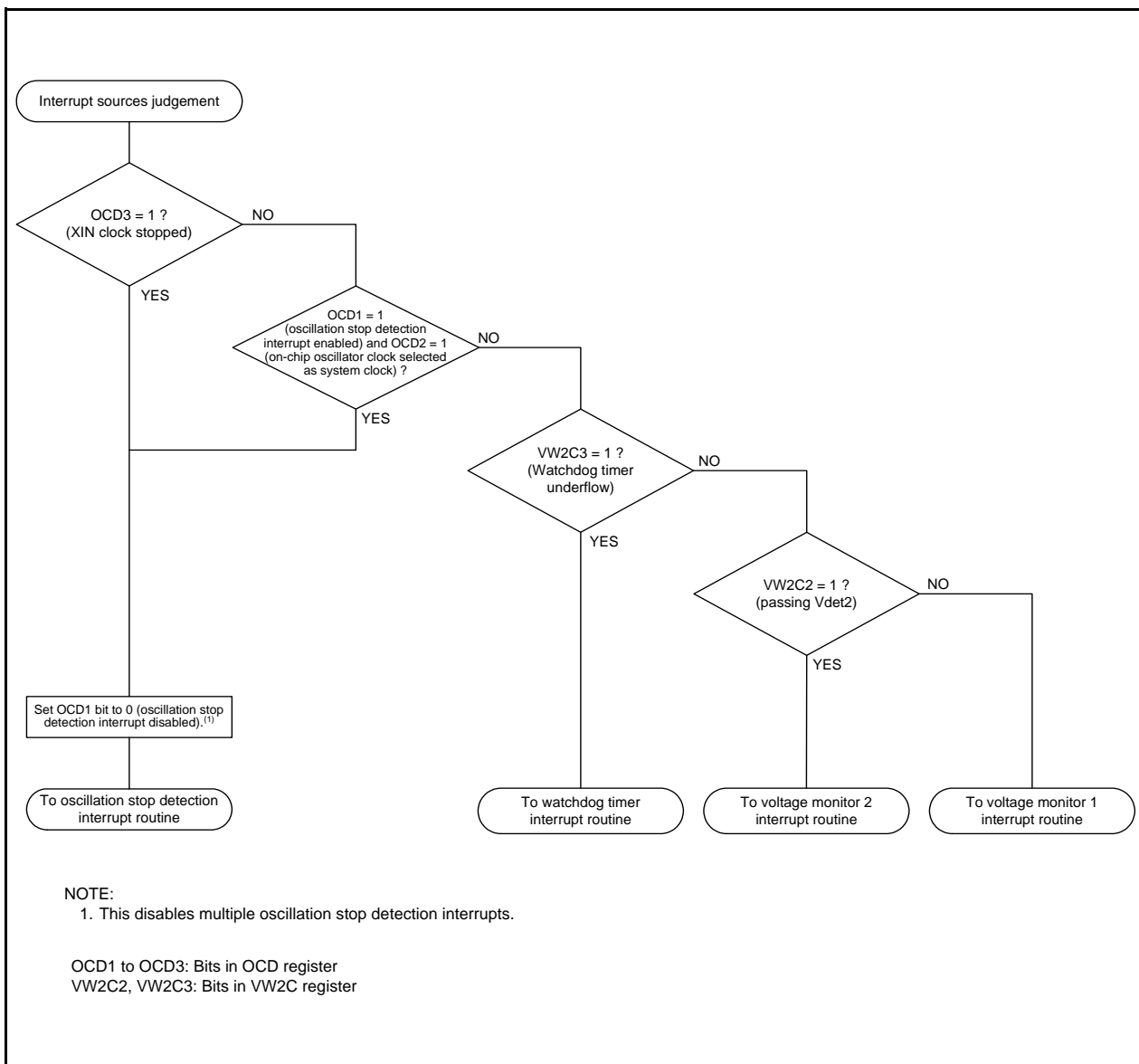

Figure 10.16 Example of Determining Interrupt Source for Oscillation Stop Detection, Watchdog Timer, Voltage Monitor 1, or Voltage Monitor 2 Interrupt

10.7 Notes on Clock Generation Circuit

10.7.1 Stop Mode

When entering stop mode, set the FMR01 bit in the FMR0 register to 0 (CPU rewrite mode disabled) and the CM10 bit in the CM1 register to 1 (stop mode). An instruction queue pre-reads 4 bytes from the instruction which sets the CM10 bit to 1 (stop mode) and the program stops.

Insert at least 4 NOP instructions following the JMP.B instruction after the instruction which sets the CM10 bit to 1.

- Program example to enter stop mode

```

BCLR      1,FMR0      ; CPU rewrite mode disabled
BSET      0,PRCR      ; Protect disabled
BSET      0,CM1       ; Stop mode
JMP.B     LABEL_001
LABEL_001 :
NOP
NOP
NOP
NOP

```

10.7.2 Wait Mode

When entering wait mode, set the FMR01 bit in the FMR0 register to 0 (CPU rewrite mode disabled) and execute the WAIT instruction. An instruction queue pre-reads 4 bytes from the WAIT instruction and the program stops. Insert at least 4 NOP instructions after the WAIT instruction.

- Program example to execute the WAIT instruction

```

FSET      I           ; Enable interrupt
BCLR      1,FMR0      ; CPU rewrite mode disabled
WAIT      ; Wait mode
NOP
NOP
NOP
NOP

```

10.7.3 Oscillation Stop Detection Function

Since the oscillation stop detection function cannot be used if the XIN clock frequency is 2 MHz or below, set bits OCD1 to OCD0 to 00b.

10.7.4 Oscillation Circuit Constants

Ask the manufacturer of the oscillator to specify the best oscillation circuit constants for your system.

To use this MCU with supply voltage below $VCC = 2.7$ V, it is recommended to set the CM11 bit in the CM1 register to 1 (on-chip feedback resistor disabled), the CM15 bit to 1 (high drive capacity), and connect the feedback resistor to the chip externally.

11. Protection

The protection function protects important registers from being easily overwritten when a program runs out of control. Figure 11.1 shows the PRCR Register. The registers protected by the PRCR register are listed below.

- Registers protected by PRC0 bit: Registers CM0, CM1, OCD, FRA0, FRA1, and FRA2
- Registers protected by PRC1 bit: Registers PM0 and PM1
- Registers protected by PRC2 bit: PD0 register
- Registers protected by PRC3 bit: Registers VCA2, VW0C, VW1C, and VW2C

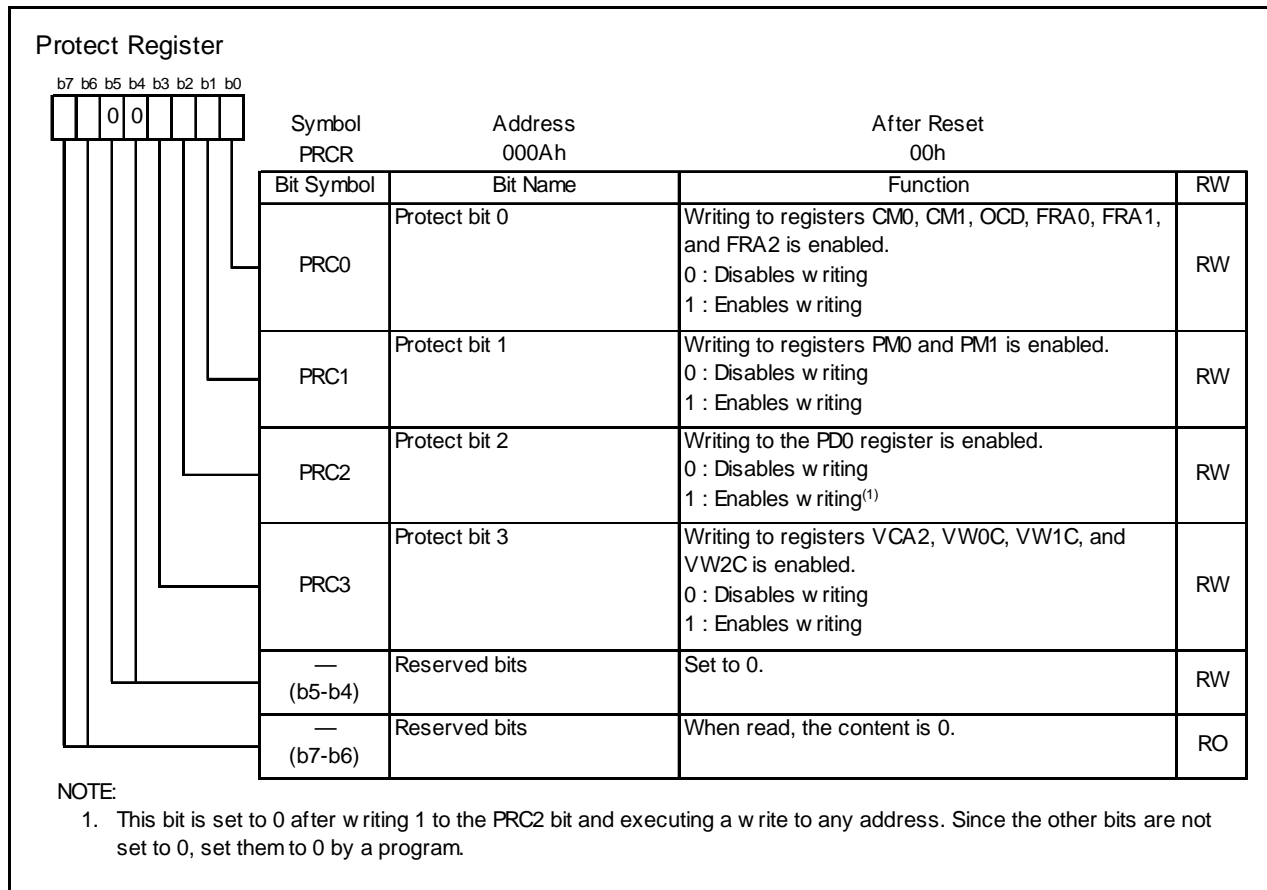

Figure 11.1 PRCR Register

12. Interrupts

12.1 Interrupt Overview

12.1.1 Types of Interrupts

Figure 12.1 shows the types of Interrupts.

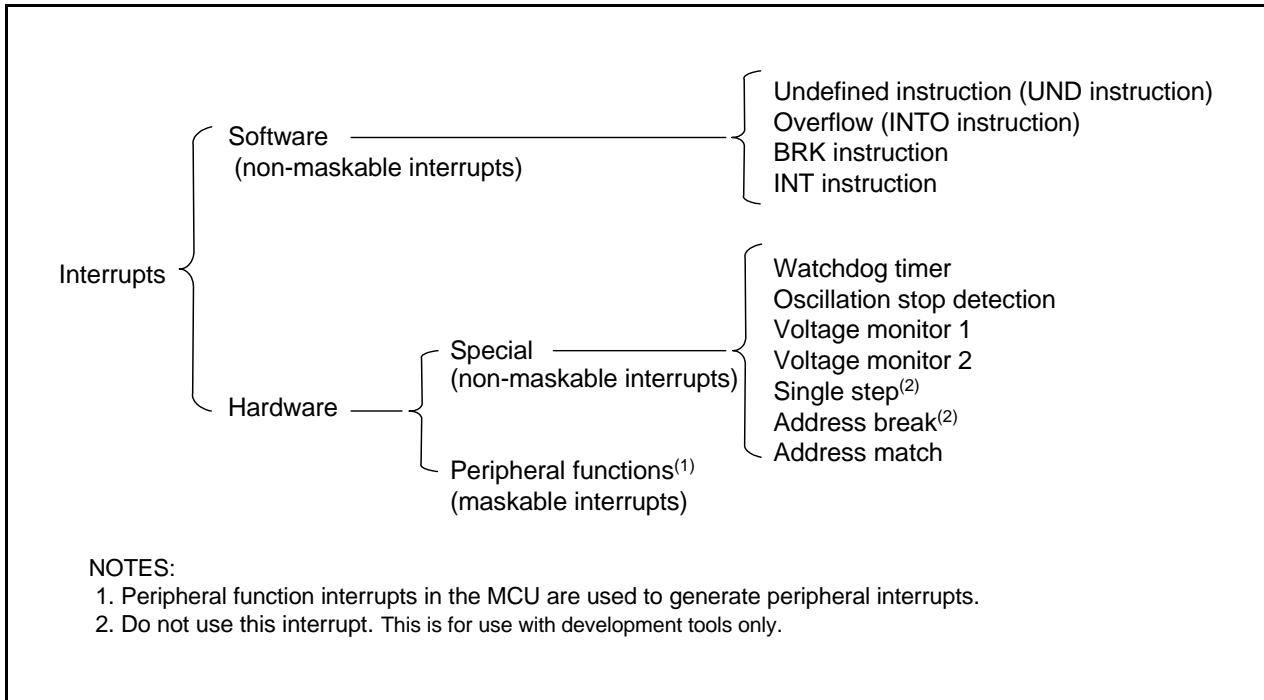

Figure 12.1 Interrupts

- **Maskable Interrupts:** The interrupt enable flag (I flag) enables or disables these interrupts. The interrupt priority order can be changed based on the interrupt priority level.
- **Non-Maskable Interrupts:** The interrupt enable flag (I flag) does not enable or disable these interrupts. The interrupt priority order cannot be changed based on interrupt priority level.

12.1.2 Software Interrupts

A software interrupt is generated when an instruction is executed. Software interrupts are non-maskable.

12.1.2.1 Undefined Instruction Interrupt

The undefined instruction interrupt is generated when the UND instruction is executed.

12.1.2.2 Overflow Interrupt

The overflow interrupt is generated when the O flag is set to 1 (arithmetic operation overflow) and the INTO instruction is executed. Instructions that set the O flag are: ABS, ADC, ADCF, ADD, CMP, DIV, DIVU, DIVX, NEG, RMPA, SBB, SHA, and SUB.

12.1.2.3 BRK Interrupt

A BRK interrupt is generated when the BRK instruction is executed.

12.1.2.4 INT Instruction Interrupt

An INT instruction interrupt is generated when the INT instruction is executed. The INT instruction can select software interrupt numbers 0 to 63. Software interrupt numbers 3 to 31 are assigned to the peripheral function interrupt. Therefore, the MCU executes the same interrupt routine when the INT instruction is executed as when a peripheral function interrupt is generated. For software interrupt numbers 0 to 31, the U flag is saved to the stack during instruction execution and the U flag is set to 0 (ISP selected) before the interrupt sequence is executed. The U flag is restored from the stack when returning from the interrupt routine. For software interrupt numbers 32 to 63, the U flag does not change state during instruction execution, and the selected SP is used.

12.1.3 Special Interrupts

Special interrupts are non-maskable.

12.1.3.1 Watchdog Timer Interrupt

The watchdog timer interrupt is generated by the watchdog timer. Reset the watchdog timer after the watchdog timer interrupt is generated. For details, refer to **13. Watchdog Timer**.

12.1.3.2 Oscillation Stop Detection Interrupt

The oscillation stop detection interrupt is generated by the oscillation stop detection function. For details of the oscillation stop detection function, refer to **10. Clock Generation Circuit**.

12.1.3.3 Voltage Monitor 1 Interrupt

The voltage monitor 1 interrupt is generated by the voltage detection circuit. For details of the voltage detection circuit, refer to **6. Voltage Detection Circuit**.

12.1.3.4 Voltage Monitor 2 Interrupt

The voltage monitor 2 interrupt is generated by the voltage detection circuit. For details of the voltage detection circuit, refer to **6. Voltage Detection Circuit**.

12.1.3.5 Single-Step Interrupt, and Address Break Interrupt

Do not use these interrupts. They are for use by development tools only.

12.1.3.6 Address Match Interrupt

The address match interrupt is generated immediately before executing an instruction that is stored at an address indicated by registers RMAD0 to RMAD1 when the AIER0 or AIER1 bit in the AIER register is set to 1 (address match interrupt enable). For details of the address match interrupt, refer to **12.4 Address Match Interrupt**.

12.1.4 Peripheral Function Interrupt

The peripheral function interrupt is generated by the internal peripheral function of the MCU and is a maskable interrupt. Refer to **Table 12.2 Relocatable Vector Tables** for sources of the peripheral function interrupt. For details of peripheral functions, refer to the descriptions of individual peripheral functions.

12.1.5 Interrupts and Interrupt Vectors

There are 4 bytes in each vector. Set the starting address of an interrupt routine in each interrupt vector. When an interrupt request is acknowledged, the CPU branches to the address set in the corresponding interrupt vector. Figure 12.2 shows an Interrupt Vector.

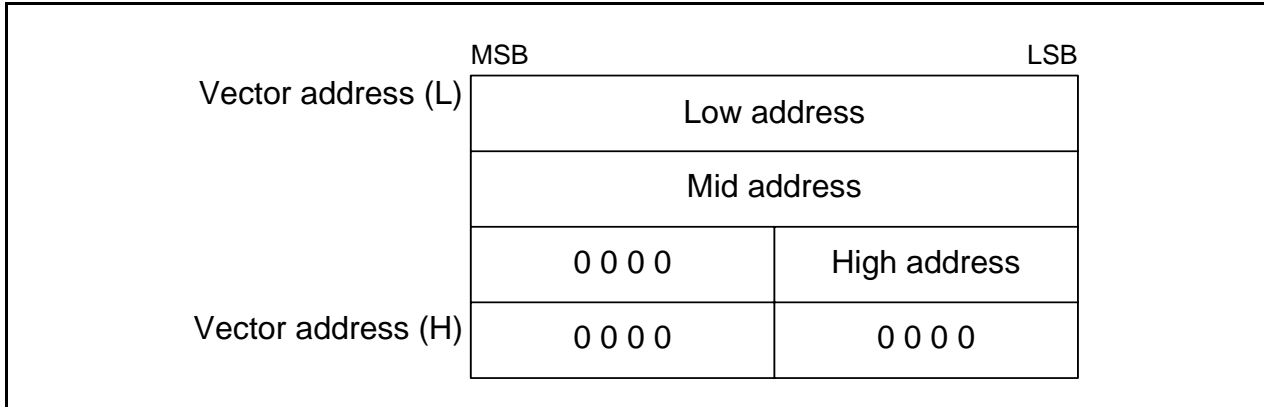

Figure 12.2 Interrupt Vector

12.1.5.1 Fixed Vector Tables

The fixed vector tables are allocated addresses 0FFDCh to 0FFFFh.

Table 12.1 lists the Fixed Vector Tables. The vector addresses (H) of fixed vectors are used by the ID code check function. For details, refer to **19.3 Functions to Prevent Rewriting of Flash Memory**.

Table 12.1 Fixed Vector Tables

Interrupt Source	Vector Addresses Address (L) to (H)	Remarks	Reference
Undefined instruction	0FFDCh to 0FFDFh	Interrupt on UND instruction	R8C/Tiny Series Software Manual
Overflow	0FFE0h to 0FFE3h	Interrupt on INTO instruction	
BRK instruction	0FFE4h to 0FFE7h	If the content of address 0FFE7h is FFh, program execution starts from the address shown by the vector in the relocatable vector table.	
Address match	0FFE8h to 0FFEBh		12.4 Address Match Interrupt
Single step ⁽¹⁾	0FFEC h to 0FFEFh		
Watchdog timer, Oscillation stop detection, Voltage monitor 1, Voltage monitor 2	0FFF0h to 0FFF3h		13. Watchdog Timer 10. Clock Generation Circuit 6. Voltage Detection Circuit
Address break ⁽¹⁾	0FFF4h to 0FFF7h		
(Reserved)	0FFF8h to 0FFFBh		
Reset	0FFFCh to 0FFFFh		5. Resets

NOTES:

1. Do not use these interrupts. They are for use by development tools only.

12.1.5.2 Relocatable Vector Tables

The relocatable vector tables occupy 256 bytes beginning from the starting address set in the INTB register. Table 12.2 lists the Relocatable Vector Tables.

Table 12.2 Relocatable Vector Tables

Interrupt Source	Vector Addresses ⁽¹⁾ Address (L) to Address (H)	Software Interrupt Number	Interrupt Control Register	Reference
BRK instruction ⁽³⁾	+0 to +3 (0000h to 0003h)	0	–	R8C/Tiny Series Software Manual
(Reserved)		1 to 2	–	
(Reserved)		3 to 7	–	
Timer RD (channel 0)	+32 to +35 (0020h to 0023h)	8	TRD0IC	14.3 Timer RD
Timer RD (channel 1)	+36 to +39 (0024h to 0027h)	9	TRD1IC	
Timer RE	+40 to +43 (0028h to 002Bh)	10	TREIC	14.4 Timer RE
(Reserved)		11 to 12	–	–
Key input	+52 to +55 (0034h to 0037h)	13	KUPIC	12.3 Key Input Interrupt
A/D	+56 to +59 (0038h to 003Bh)	14	ADIC	18. A/D Converter
Clock synchronous serial I/O with chip select / I ² C bus interface ⁽²⁾	+60 to +63 (003Ch to 003Fh)	15	SSUIC/IICIC	16.2 Clock Synchronous Serial I/O with Chip Select (SSU), 16.3 I ² C bus Interface
(Reserved)		16	–	–
UART0 transmit	+68 to +71 (0044h to 0047h)	17	S0TIC	15. Serial Interface
UART0 receive	+72 to +75 (0048h to 004Bh)	18	S0RIC	
UART1 transmit	+76 to +79 (004Ch to 004Fh)	19	S1TIC	
UART1 receive	+80 to +83 (0050h to 0053h)	20	S1RIC	
$\overline{\text{INT}}_2$	+84 to +87 (0054h to 0057h)	21	INT2IC	12.2 $\overline{\text{INT}}$ Interrupt
Timer RA	+88 to +91 (0058h to 005Bh)	22	TRAIC	14.1 Timer RA
(Reserved)		23	–	–
Timer RB	+96 to +99 (0060h to 0063h)	24	TRBIC	14.2 Timer RB
$\overline{\text{INT}}_1$	+100 to +103 (0064h to 0067h)	25	INT1IC	12.2 $\overline{\text{INT}}$ Interrupt
$\overline{\text{INT}}_3$	+104 to +107 (0068h to 006Bh)	26	INT3IC	
(Reserved)		27	–	–
(Reserved)		28	–	–
$\overline{\text{INT}}_0$	+116 to +119 (0074h to 0077h)	29	INT0IC	12.2 $\overline{\text{INT}}$ Interrupt
(Reserved)		30	–	–
(Reserved)		31	–	–
Software interrupt ⁽³⁾	+128 to +131 (0080h to 0083h) to +252 to +255 (00FCh to 00FFh)	32 to 63	–	R8C/Tiny Series Software Manual

NOTES:

1. These addresses are relative to those in the INTB register.
2. The IICSEL bit in the PMR register switches functions.
3. The I flag does not disable these interrupts.

12.1.6 Interrupt Control

The following describes enabling and disabling the maskable interrupts and setting the priority for acknowledgement. The explanation does not apply to nonmaskable interrupts.

Use the I flag in the FLG register, IPL, and bits ILVL2 to ILVL0 in each interrupt control register to enable or disable maskable interrupts. Whether an interrupt is requested is indicated by the IR bit in each interrupt control register.

Figure 12.3 shows the Interrupt Control Register, Figure 12.4 shows Registers TRD0IC, TRD1IC, SSUIC, and IICIC and Figure 12.5 shows the INTiIC Register.

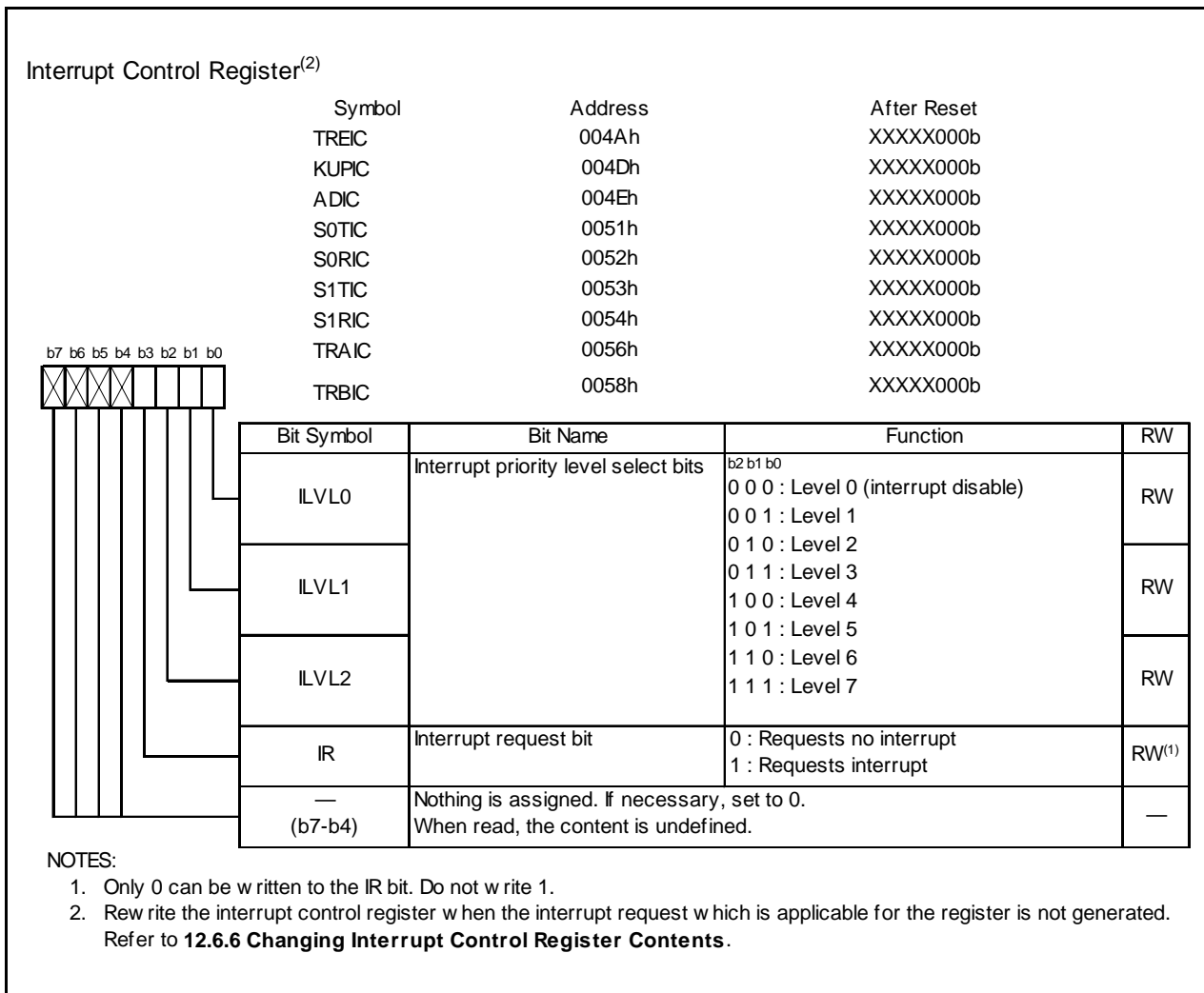

Figure 12.3 Interrupt Control Register

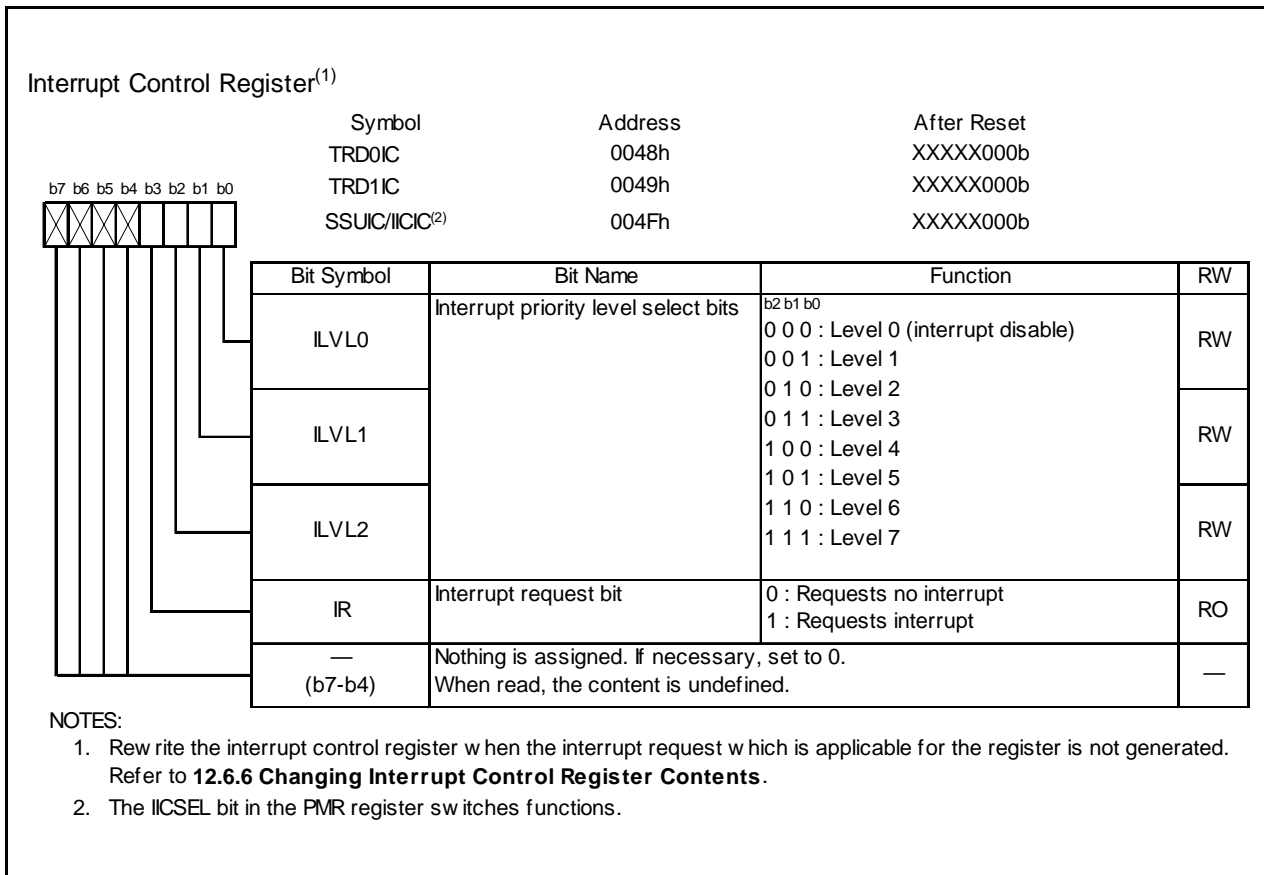
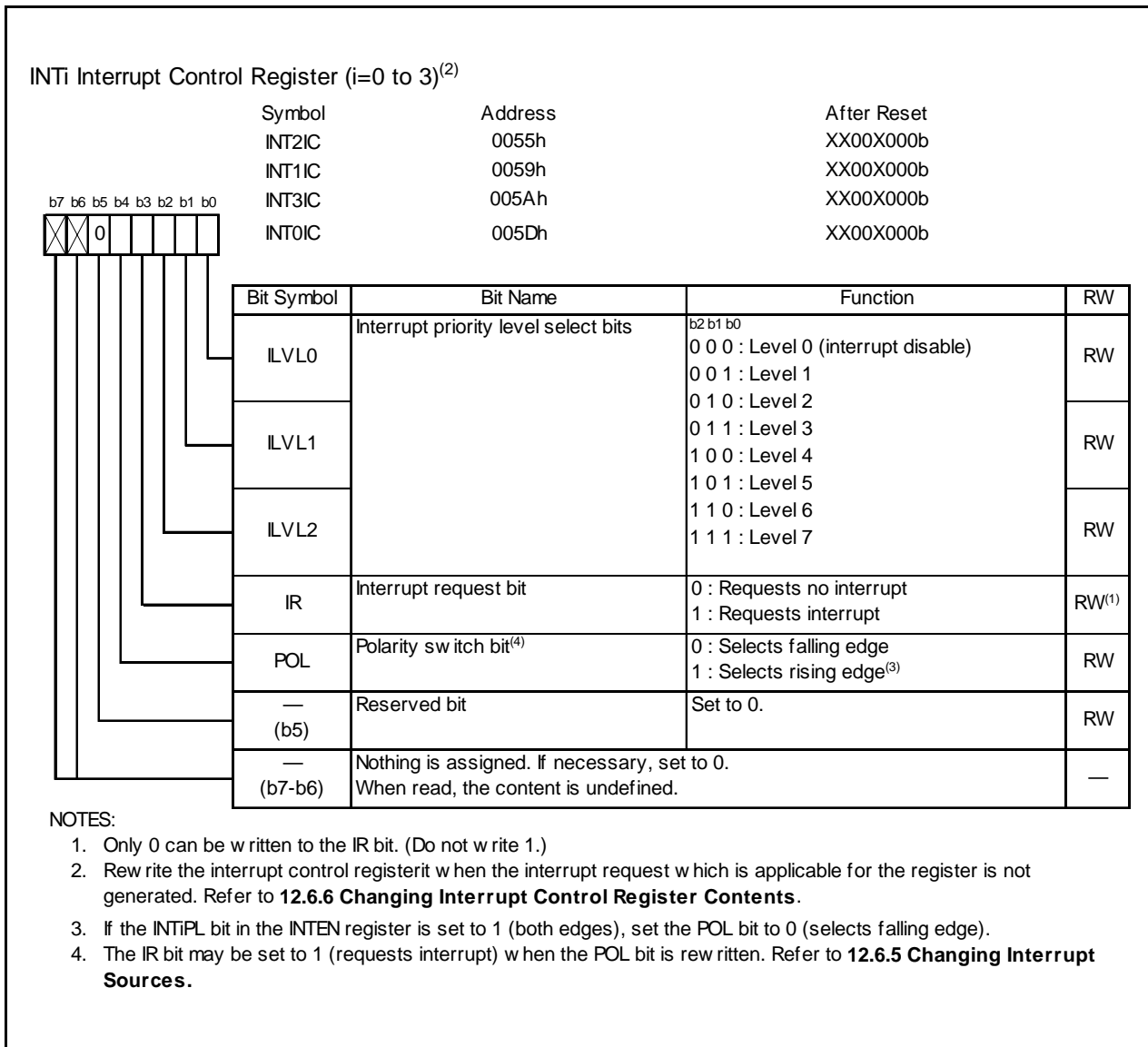

Figure 12.4 Registers TRD0IC, TRD1IC, SSUIC, and IICIC

Figure 12.5 INT_iIC Register

12.1.6.1 I Flag

The I flag enables or disables maskable interrupts. Setting the I flag to 1 (enabled) enables maskable interrupts. Setting the I flag to 0 (disabled) disables all maskable interrupts.

12.1.6.2 IR Bit

The IR bit is set to 1 (interrupt requested) when an interrupt request is generated. Then, when the interrupt request is acknowledged and the CPU branches to the corresponding interrupt vector, the IR bit is set to 0 (= interrupt not requested).

The IR bit can be set to 0 by a program. Do not write 1 to this bit.

However, the IR bit operations of the timer RD Interrupt, Clock Synchronous Serial I/O with Chip Select Interrupt and the I²C bus Interface Interrupt are different. Refer to **12.5 Timer RD Interrupt, Clock Synchronous Serial I/O with Chip Select Interrupts, and I²C bus Interface Interrupt (Interrupts with Multiple Interrupt Request Sources)**.

12.1.6.3 Bits ILVL2 to ILVL0 and IPL

Interrupt priority levels can be set using bits ILVL2 to ILVL0.

Table 12.3 lists the Settings of Interrupt Priority Levels and Table 12.4 lists the Interrupt Priority Levels Enabled by IPL.

The following are conditions under which an interrupt is acknowledged:

- I flag = 1
- IR bit = 1
- Interrupt priority level > IPL

The I flag, IR bit, bits ILVL2 to ILVL0, and IPL are independent of each other. They do not affect one another.

Table 12.3 Settings of Interrupt Priority Levels

ILVL2 to ILVL0 Bits	Interrupt Priority Level	Priority Order
000b	Level 0 (interrupt disabled)	–
001b	Level 1	Low  High
010b	Level 2	
011b	Level 3	
100b	Level 4	
101b	Level 5	
110b	Level 6	
111b	Level 7	

Table 12.4 Interrupt Priority Levels Enabled by IPL

IPL	Enabled Interrupt Priority Levels
000b	Interrupt level 1 and above
001b	Interrupt level 2 and above
010b	Interrupt level 3 and above
011b	Interrupt level 4 and above
100b	Interrupt level 5 and above
101b	Interrupt level 6 and above
110b	Interrupt level 7 and above
111b	All maskable interrupts are disabled

12.1.6.4 Interrupt Sequence

An interrupt sequence is performed between an interrupt request acknowledgement and interrupt routine execution.

When an interrupt request is generated while an instruction is being executed, the CPU determines its interrupt priority level after the instruction is completed. The CPU starts the interrupt sequence from the following cycle. However, for the SMOVB, SMOVF, SSTR, or RMPA instruction if an interrupt request is generated while the instruction is being executed, the MCU suspends the instruction to start the interrupt sequence. The interrupt sequence is performed as indicated below.

Figure 12.6 shows the Time Required for Executing Interrupt Sequence.

- (1) The CPU gets interrupt information (interrupt number and interrupt request level) by reading address 00000h. The IR bit for the corresponding interrupt is set to 0 (interrupt not requested).⁽²⁾
- (2) The FLG register is saved to a temporary register⁽¹⁾ in the CPU immediately before entering the interrupt sequence.
- (3) The I, D and U flags in the FLG register are set as follows:
The I flag is set to 0 (interrupts disabled).
The D flag is set to 0 (single-step interrupt disabled).
The U flag is set to 0 (ISP selected).
However, the U flag does not change state if an INT instruction for software interrupt number 32 to 63 is executed.
- (4) The CPU's internal temporary register⁽¹⁾ is saved to the stack.
- (5) The PC is saved to the stack.
- (6) The interrupt priority level of the acknowledged interrupt is set in the IPL.
- (7) The starting address of the interrupt routine set in the interrupt vector is stored in the PC.

After the interrupt sequence is completed, instructions are executed from the starting address of the interrupt routine.

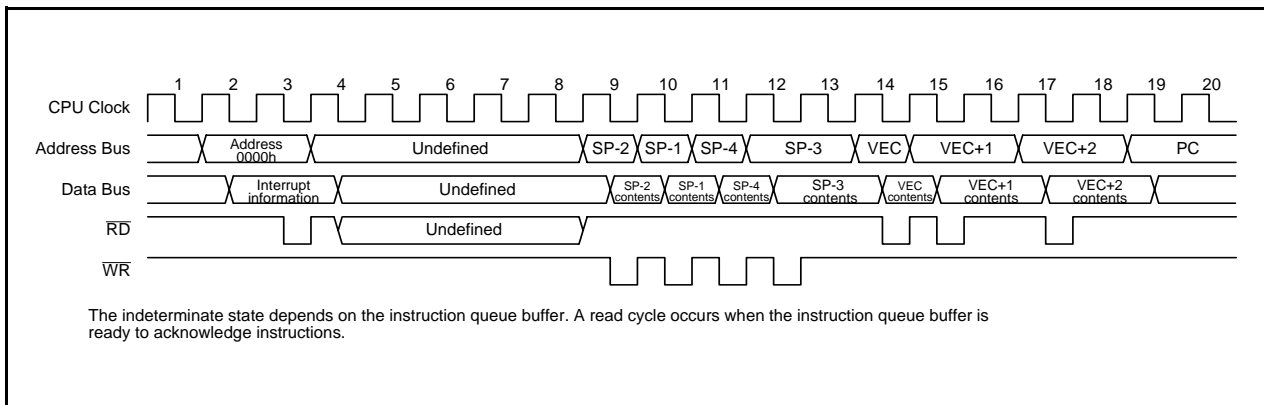

Figure 12.6 Time Required for Executing Interrupt Sequence

NOTES:

1. This register cannot be accessed by the user.
2. Refer to **12.5 Timer RD Interrupt, Clock Synchronous Serial I/O with Chip Select Interrupts, and I²C bus Interface Interrupt (Interrupts with Multiple Interrupt Request Sources)** for the IR bit operations of the timer RD Interrupt, Clock Synchronous Serial I/O with Chip Select Interrupt, and the I²C bus Interface Interrupt.

12.1.6.5 Interrupt Response Time

Figure 12.7 shows the Interrupt Response Time. The interrupt response time is the period between an interrupt request generation and the execution of the first instruction in the interrupt routine. The interrupt response time includes the period between interrupt request generation and the completion of execution of the instruction (refer to (a) in Figure 12.7) and the period required to perform the interrupt sequence (20 cycles, refer to (b) in Figure 12.7).

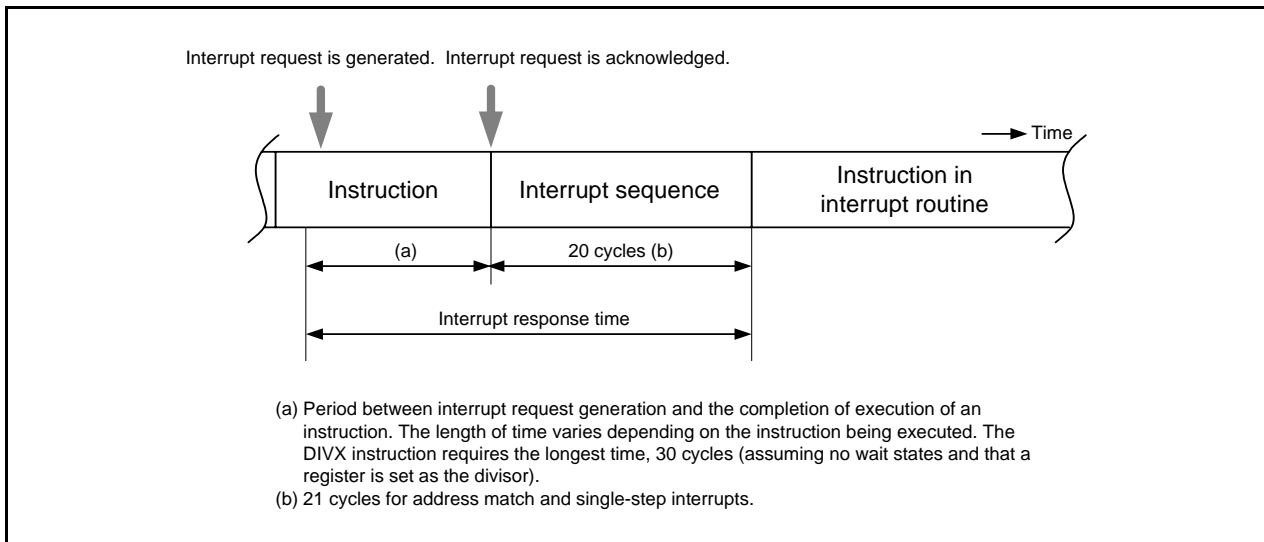

Figure 12.7 Interrupt Response Time

12.1.6.6 IPL Change when Interrupt Request is Acknowledged

When an interrupt request of a maskable interrupt is acknowledged, the interrupt priority level of the acknowledged interrupt is set in the IPL.

When a software interrupt or special interrupt request is acknowledged, the level listed in Table 12.5 is set in the IPL.

Table 12.5 lists the IPL Value When Software or Special Interrupt Is Acknowledged.

Table 12.5 IPL Value When Software or Special Interrupt Is Acknowledged

Interrupt Source	Value Set in IPL
Watchdog timer, oscillation stop detection, voltage monitor 1, voltage monitor 2, Address break	7
Software, address match, single-step	Not changed

12.1.6.7 Saving a Register

In the interrupt sequence, the FLG register and PC are saved to the stack.

After an extended 16 bits, 4 high-order bits in the PC and 4 high-order (IPL) and 8 low-order bits in the FLG register, are saved to the stack, the 16 low-order bits in the PC are saved.

Figure 12.8 shows the Stack State Before and After Acknowledgement of Interrupt Request.

The other necessary registers are saved by a program at the beginning of the interrupt routine. The PUSHM instruction can save several registers in the register bank being currently used⁽¹⁾ with a single instruction.

NOTE:

1. Selectable from registers R0, R1, R2, R3, A0, A1, SB, and FB.

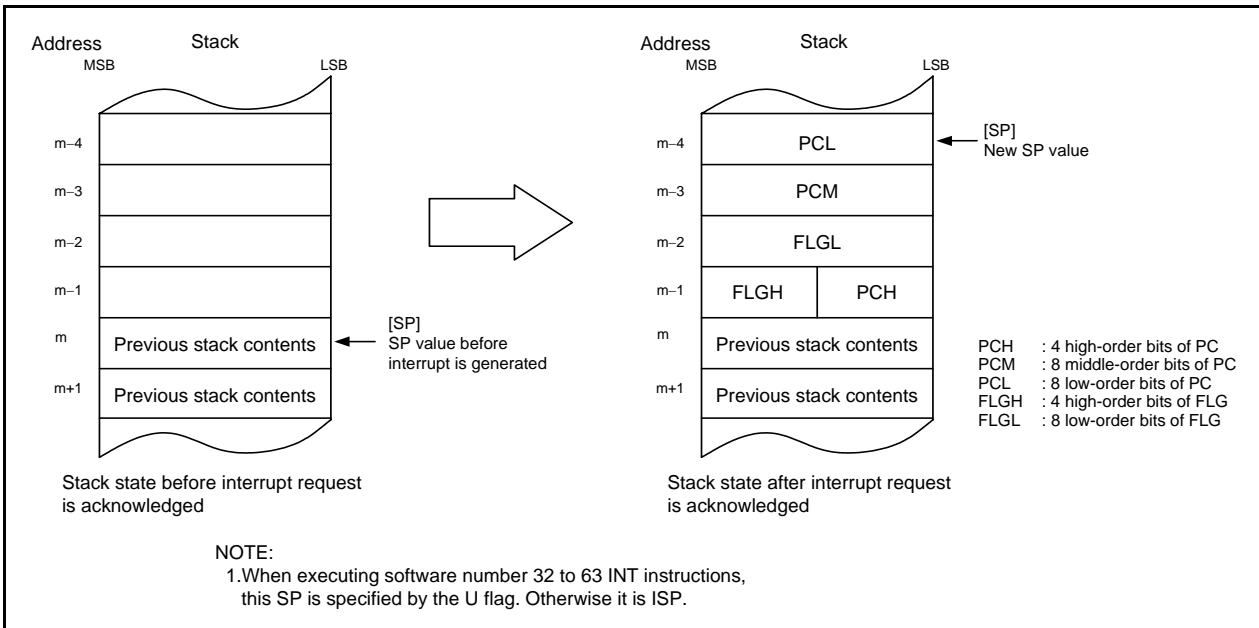

Figure 12.8 Stack State Before and After Acknowledgement of Interrupt Request

The register saving operation, which is performed as part of the interrupt sequence, saved in 8 bits at a time in four steps.

Figure 12.9 shows the Register Saving Operation.

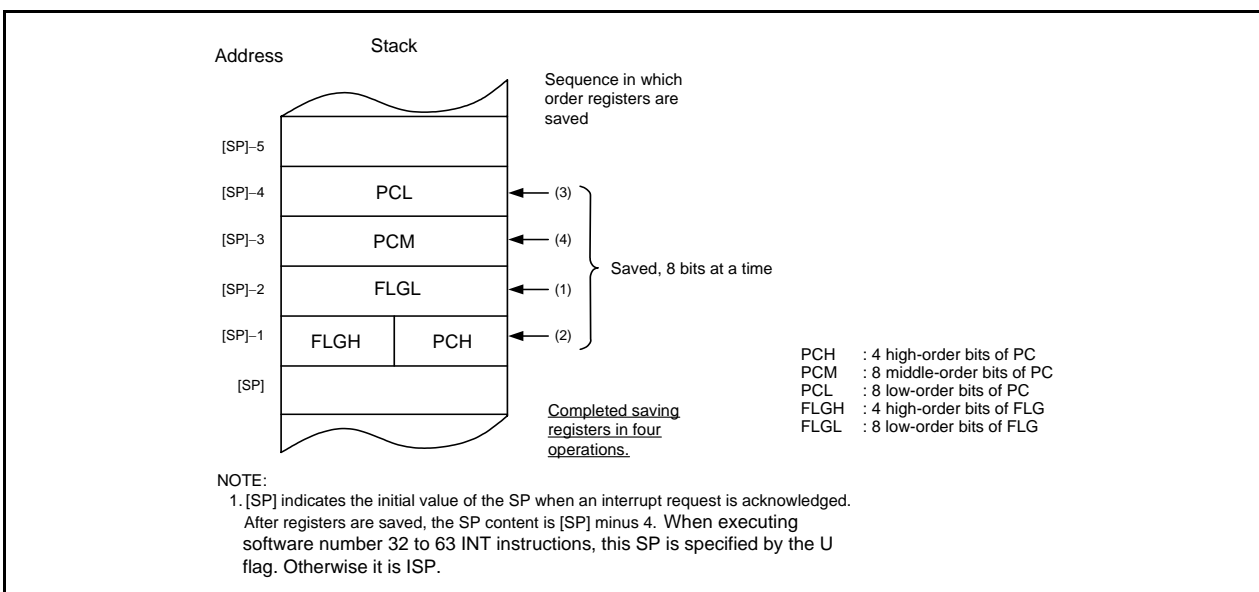

Figure 12.9 Register Saving Operation

12.1.6.8 Returning from an Interrupt Routine

When the REIT instruction is executed at the end of an interrupt routine, the FLG register and PC, which have been saved to the stack, are automatically restored. The program, that was running before the interrupt request was acknowledged, starts running again.

Restore registers saved by a program in an interrupt routine using the POPM instruction or others before executing the REIT instruction.

12.1.6.9 Interrupt Priority

If two or more interrupt requests are generated while a single instruction is being executed, the interrupt with the higher priority is acknowledged.

Set bits ILVL2 to ILVL0 to select the desired priority level for maskable interrupts (peripheral functions). However, if two or more maskable interrupts have the same priority level, their interrupt priority is resolved by hardware, and the higher priority interrupts acknowledged.

The priority levels of special interrupts, such as reset (reset has the highest priority) and watchdog timer, are set by hardware.

Figure 12.10 shows the Priority Levels of Hardware Interrupts.

The interrupt priority does not affect software interrupts. The MCU jumps to the interrupt routine when the instruction is executed.

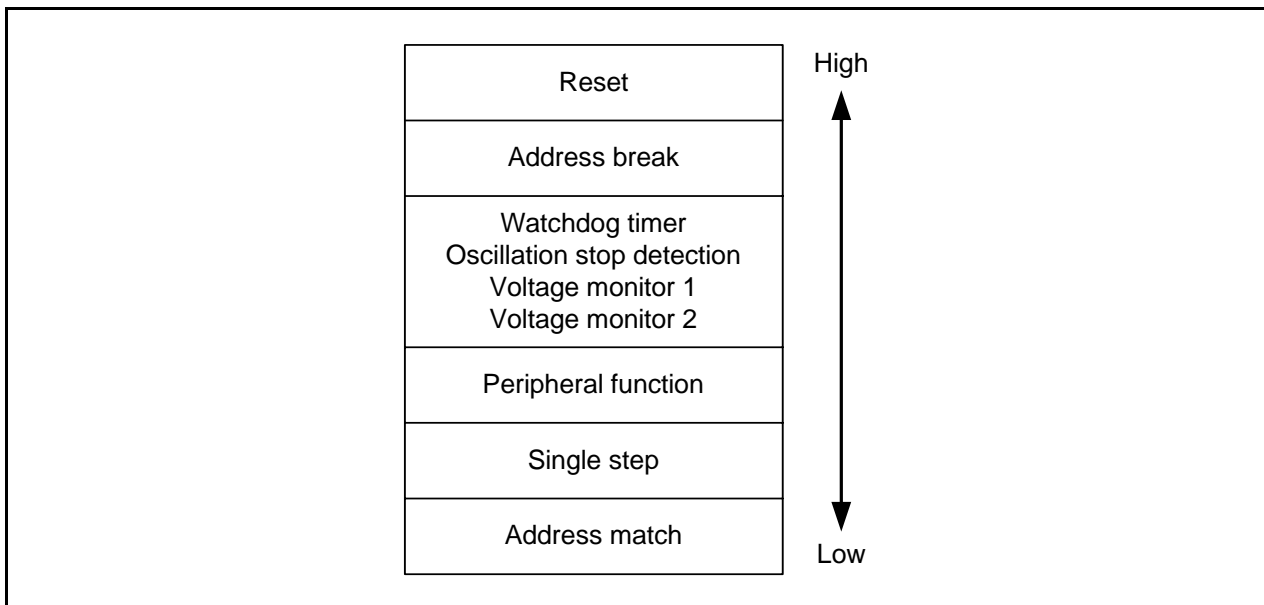

Figure 12.10 Priority Levels of Hardware Interrupts

12.1.6.10 Interrupt Priority Judgement Circuit

The interrupt priority judgement circuit selects the highest priority interrupt, as shown in Figure 12.11.

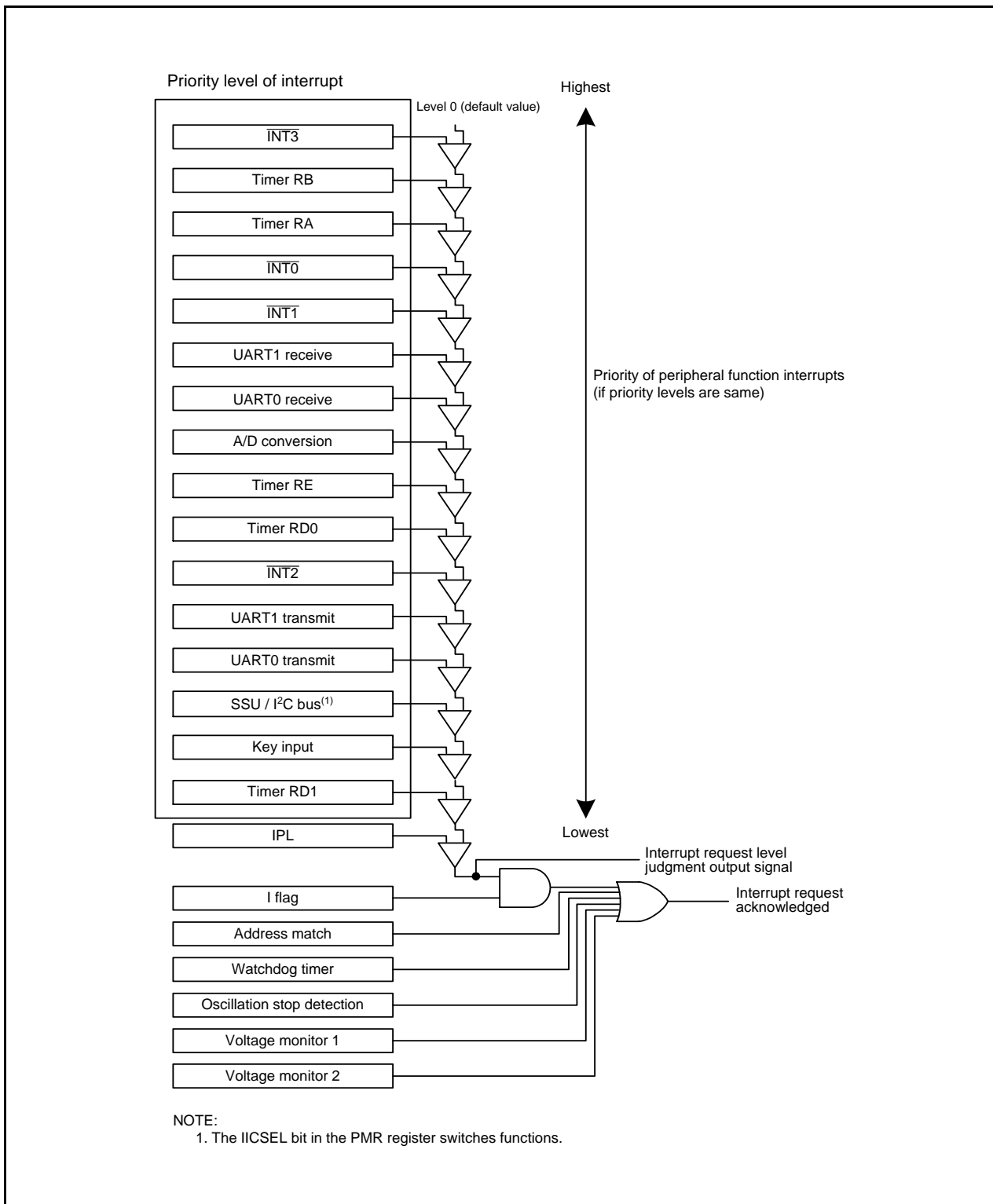

Figure 12.11 Interrupt Priority Level Judgement Circuit

12.2 $\overline{\text{INT}}$ Interrupt

12.2.1 $\overline{\text{INT}}_i$ Interrupt ($i = 0$ to 3)

The $\overline{\text{INT}}_i$ interrupt is generated by an $\overline{\text{INT}}_i$ input. When using the $\overline{\text{INT}}_i$ interrupt, the INT_iEN bit in the INTEN register is set to 1 (enable). The edge polarity is selected using the INT_iPL bit in the INTEN register and the POL bit in the INT_iIC register.

Inputs can be passed through a digital filter with three different sampling clocks.

The $\overline{\text{INT}}_0$ pin is shared with the pulse output forced cutoff of timer RD and the $\overline{\text{INT}}_1$ pin is shared with the external trigger input pin of timer RA.

Figure 12.12 shows the INTEN Register. Figure 12.13 shows the INTF Register.

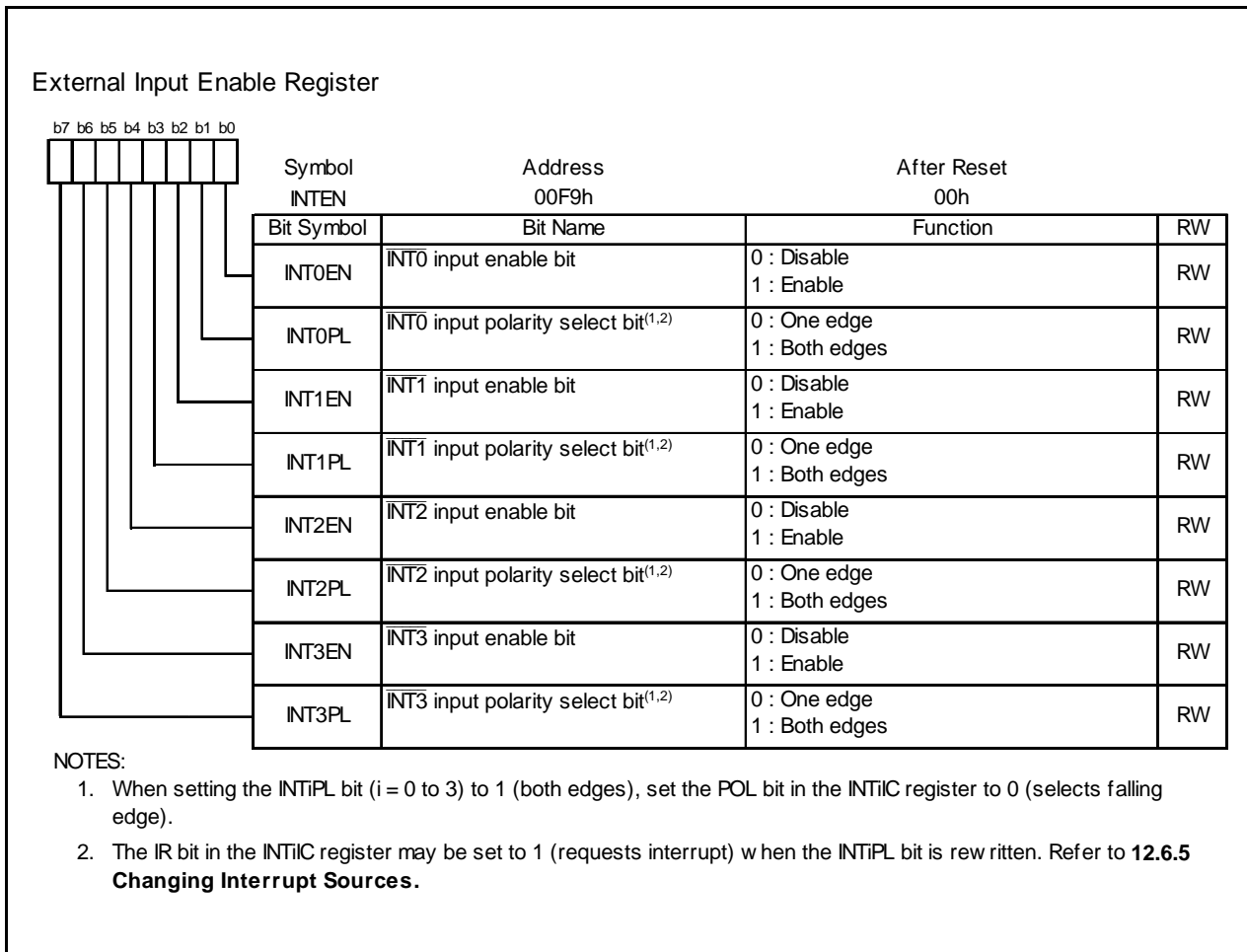

Figure 12.12 INTEN Register

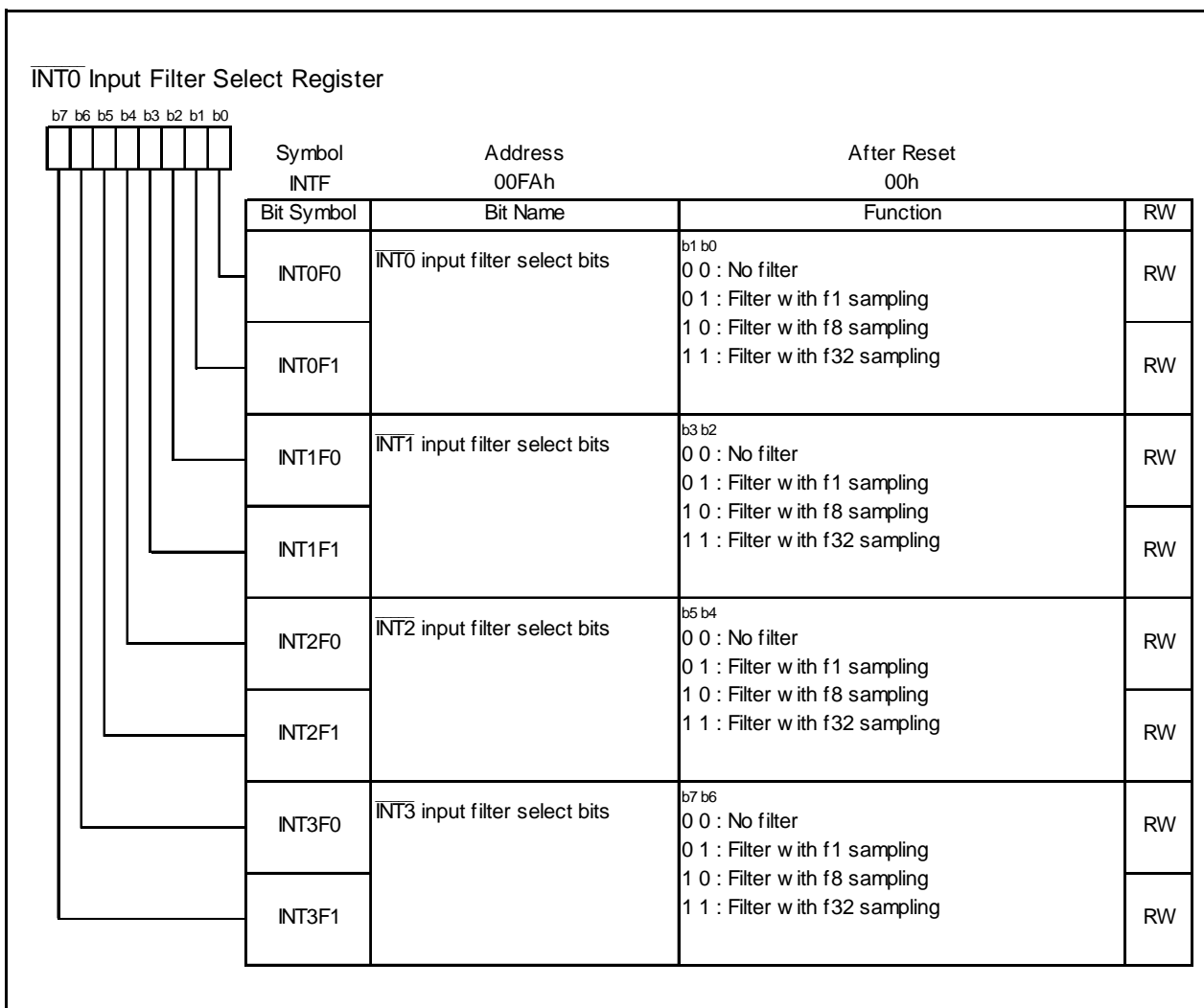

Figure 12.13 INTF Register

12.2.2 $\overline{\text{INT}}_i$ Input Filter (i = 0 to 3)

The $\overline{\text{INT}}_i$ input contains a digital filter. The sampling clock is selected by bits INTiF1 to INTiF0 in the INTF register.

The $\overline{\text{INT}}_i$ level is sampled every sampling clock cycle and if the sampled input level matches three times, the IR bit in the INTiC register is set to 1 (interrupt requested).

Figure 12.14 shows the Configuration of $\overline{\text{INT}}_i$ Input Filter. Figure 12.15 shows an Operating Example of $\overline{\text{INT}}_i$ Input Filter.

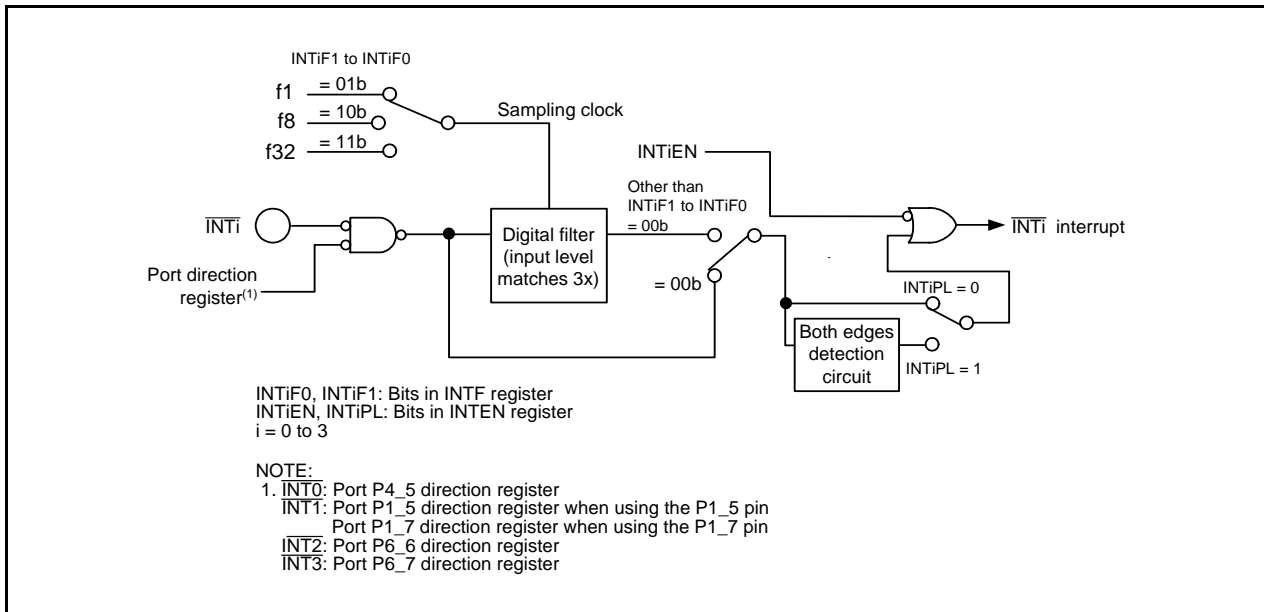

Figure 12.14 Configuration of $\overline{\text{INT}}_i$ Input Filter

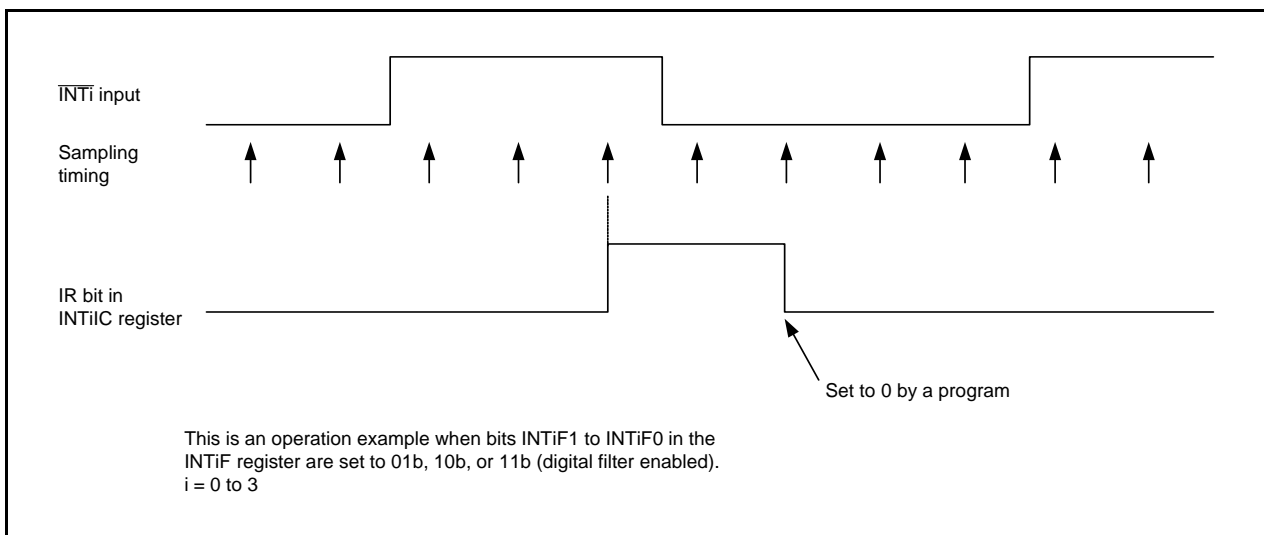

Figure 12.15 Operating Example of $\overline{\text{INT}}_i$ Input Filter

12.3 Key Input Interrupt

A key input interrupt request is generated by one of the input edges of pins $\overline{K10}$ to $\overline{K13}$. The key input interrupt can be used as a key-on wake-up function to exit wait or stop mode.

The $KIiEN$ ($i = 0$ to 3) bit in the $KIEN$ register can select whether or not the pins are used as \overline{KIi} input. The $KIiPL$ bit in the $KIEN$ register can select the input polarity.

When inputting “L” to the \overline{KIi} pin which sets the $KIiPL$ bit to 0 (falling edge), the input of the other pins $\overline{K10}$ to $\overline{K13}$ is not detected as interrupts. Also, when inputting “H” to the \overline{KIi} pin, which sets the $KIiPL$ bit to 1 (rising edge), the input of the other pins $\overline{K10}$ to $\overline{K13}$ is not detected as interrupts.

Figure 12.16 shows a Block Diagram of Key Input Interrupt.

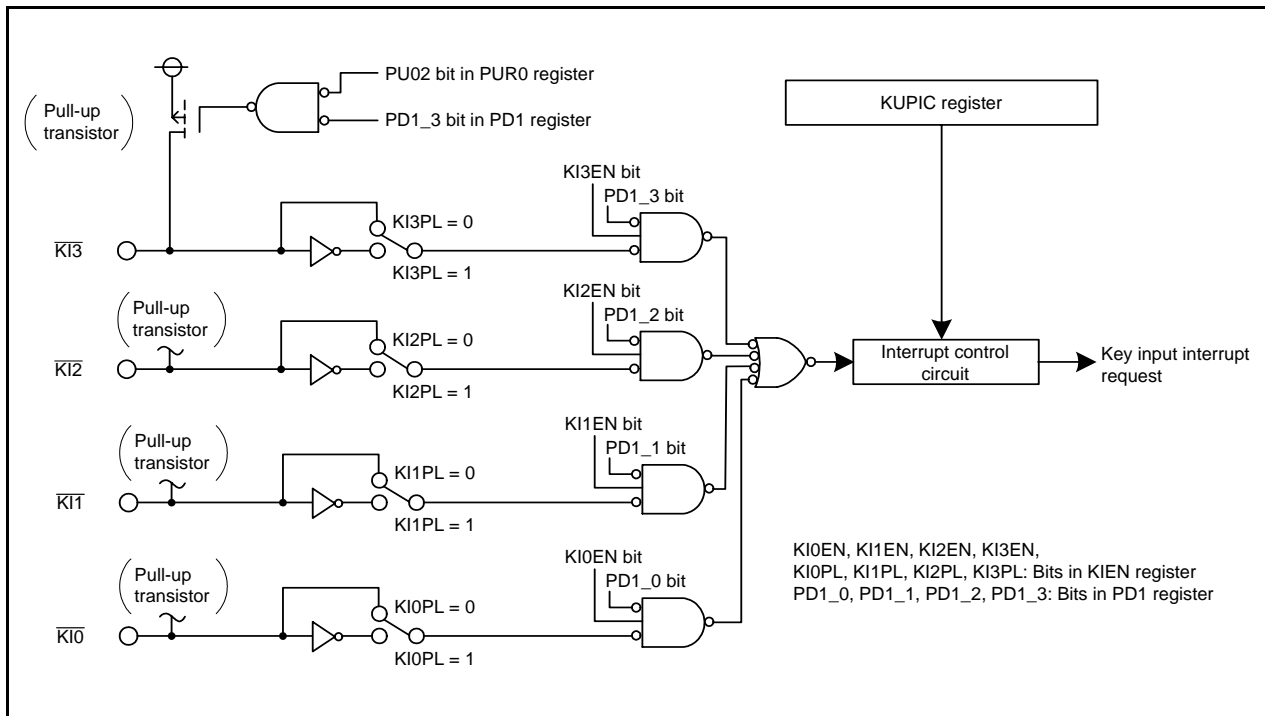

Figure 12.16 Block Diagram of Key Input Interrupt

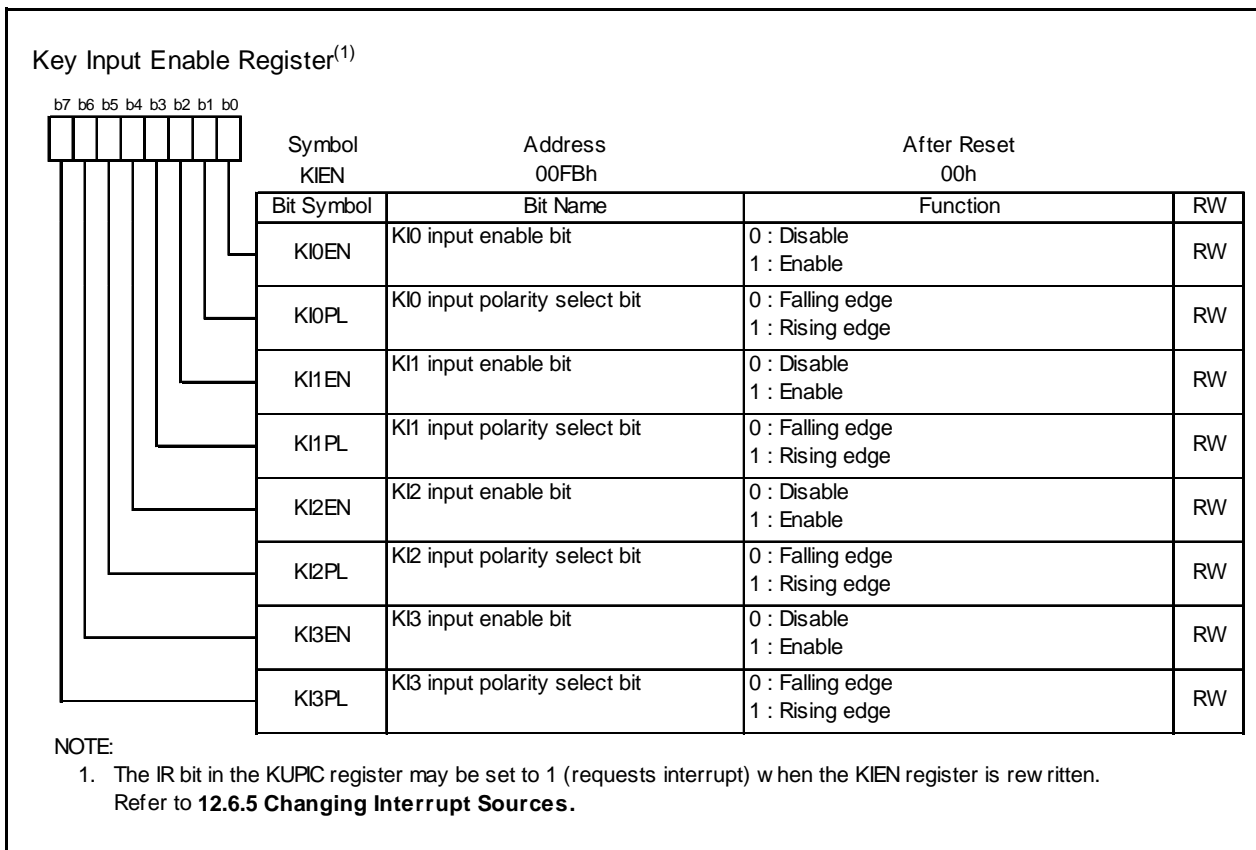

Figure 12.17 KIEN Register

12.4 Address Match Interrupt

An address match interrupt request is generated immediately before execution of the instruction at the address indicated by the RMADi register (i = 0 or 1). This interrupt is used as a break function by the debugger. When using the on-chip debugger, do not set an address match interrupt (registers of AIER, RMAD0, and RMAD1 and fixed vector tables) in a user system.

Set the starting address of any instruction in the RMADi register. Bits AIER0 and AIER1 in the AIER0 register can be used to select enable or disable of the interrupt. The I flag and IPL do not affect the address match interrupt. The value of the PC (Refer to **12.1.6.7 Saving a Register** for the value of the PC) which is saved to the stack when an address match interrupt is acknowledged varies depending on the instruction at the address indicated by the RMADi register. (The appropriate return address is not saved on the stack.) When returning from the address match interrupt, return by one of the following means:

- Change the content of the stack and use the REIT instruction.
- Use an instruction such as POP to restore the stack as it was before the interrupt request was acknowledged. Then use a jump instruction.

Table 12.6 lists the Values of PC Saved to Stack when Address Match Interrupt is Acknowledged.

Figure 12.18 shows Registers AIER and RMAD0 to RMAD1.

Table 12.6 Values of PC Saved to Stack when Address Match Interrupt is Acknowledged

Address Indicated by RMADi Register (i = 0 or 1)	PC Value Saved ⁽¹⁾
<ul style="list-style-type: none"> • 16-bit operation code instruction • Instruction shown below among 8-bit operation code instructions ADD.B:S #IMM8,dest SUB.B:S #IMM8,dest AND.B:S #IMM8,dest OR.B:S #IMM8,dest MOV.B:S #IMM8,dest STZ.B:S #IMM8,dest STNZ.B:S #IMM8,dest STZX.B:S #IMM81,#IMM82,dest CMP.B:S #IMM8,dest PUSHM src POPM dest JMPS #IMM8 JSRS #IMM8 MOV.B:S #IMM,dest (however, dest = A0 or A1)	Address indicated by RMADi register + 2
<ul style="list-style-type: none"> • Instructions other than the above 	Address indicated by RMADi register + 1

NOTE:

1. Refer to the **12.1.6.7 Saving a Register** for the PC value saved.

Table 12.7 Correspondence Between Address Match Interrupt Sources and Associated Registers

Address Match Interrupt Source	Address Match Interrupt Enable Bit	Address Match Interrupt Register
Address match interrupt 0	AIER0	RMAD0
Address match interrupt 1	AIER1	RMAD1

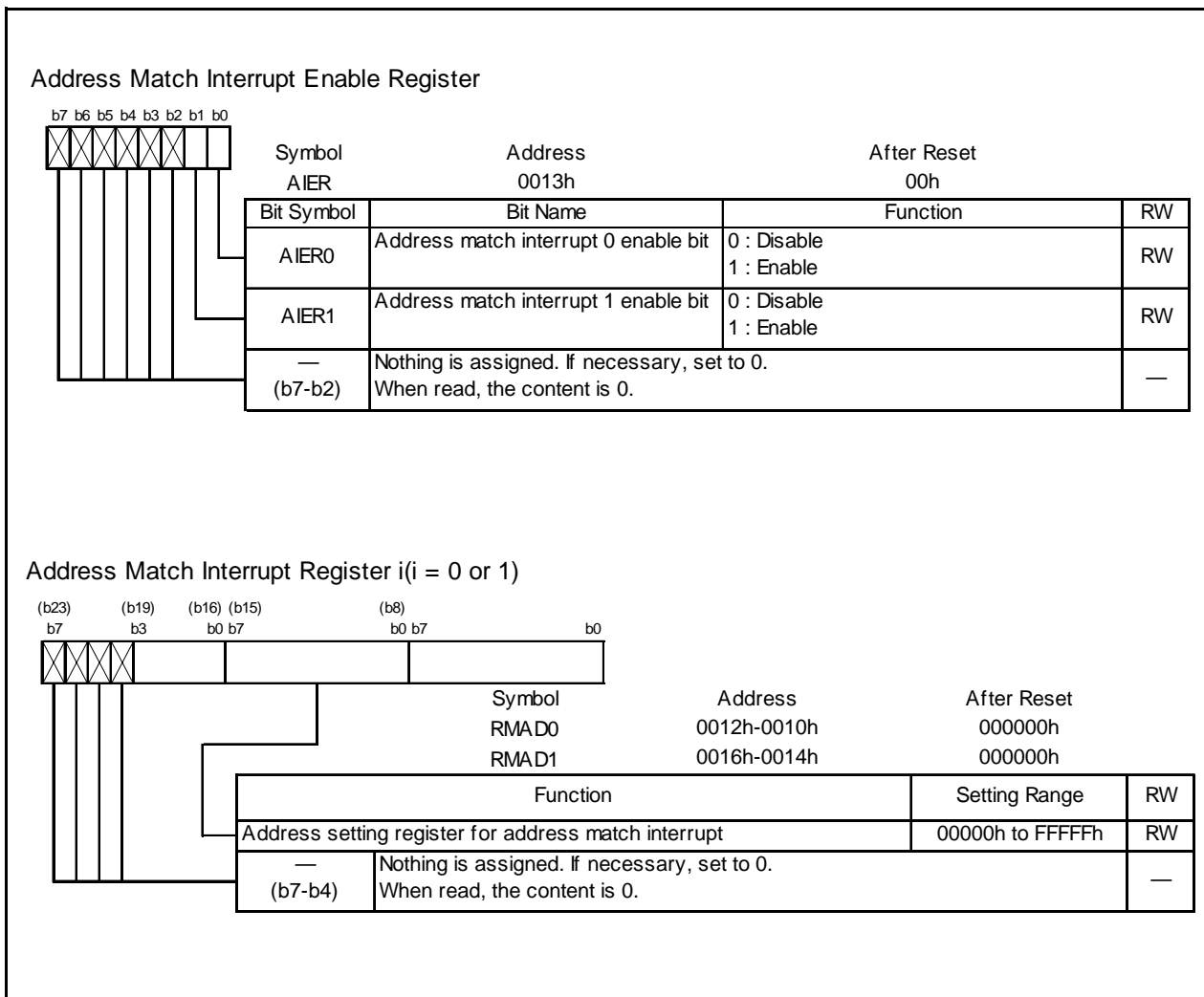

Figure 12.18 Registers AIER and RMAD0 to RMAD1

12.5 Timer RD Interrupt, Clock Synchronous Serial I/O with Chip Select Interrupts, and I²C bus Interface Interrupt (Interrupts with Multiple Interrupt Request Sources)

The timer RD (channel 0) interrupt, timer RD (channel 1) interrupt, clock synchronous serial I/O with chip select interrupt, and I²C bus interface interrupt each have multiple interrupt request sources. An interrupt request is generated by the logical OR of several interrupt request factors and is reflected in the IR bit in the corresponding interrupt control register. Therefore, each of these peripheral functions has its own interrupt request source status register (status register) and interrupt request source enable register (enable register) to control the generation of interrupt requests (change the IR bit in the interrupt control register). Table 12.8 lists the Registers Associated with Timer RD Interrupt, Clock Synchronous Serial I/O with Chip Select Interrupt, and I²C bus Interface Interrupt and Figure 12.19 shows a Block Diagram of Timer RD Interrupt.

Table 12.8 Registers Associated with Timer RD Interrupt, Clock Synchronous Serial I/O with Chip Select Interrupt, and I²C bus Interface Interrupt

		Status Register of Interrupt Request Source	Enable Register of Interrupt Request Source	Interrupt Control Register
Timer RD	Channel 0	TRDSR0	TRDIER0	TRD0IC
	Channel 1	TRDSR1	TRDIER1	TRD1IC
Clock synchronous serial I/O with chip select		SSSR	SSER	SSUIC
I ² C bus interface		ICSR	ICIER	IICIC

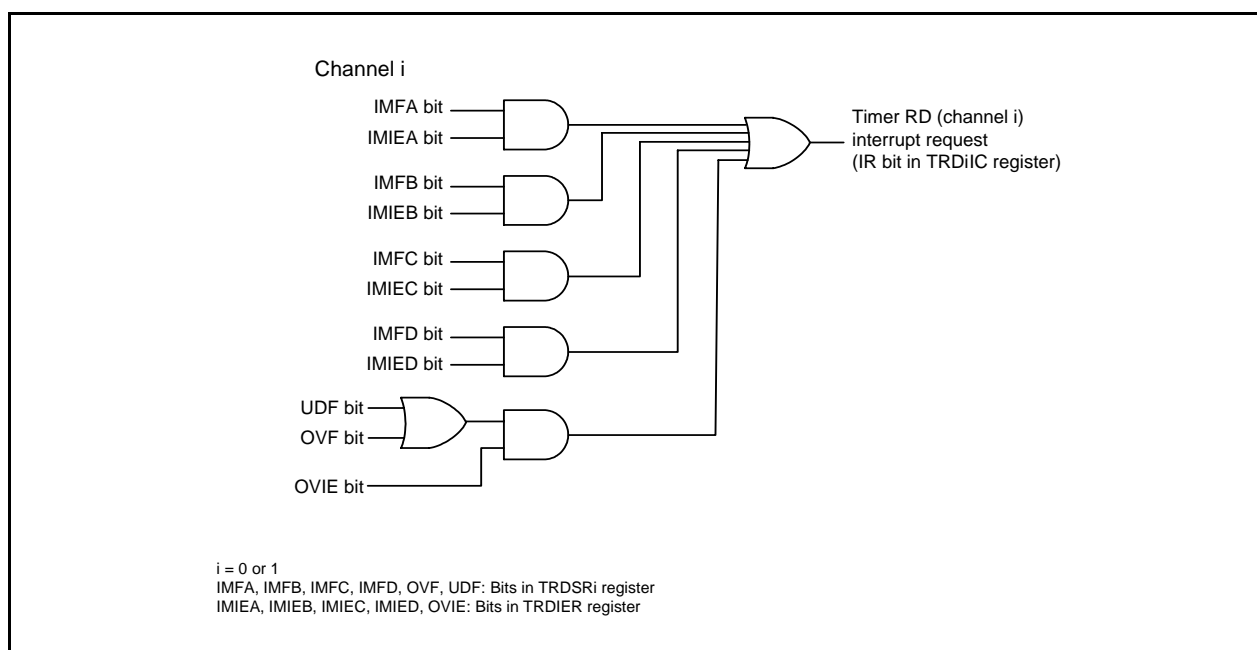

Figure 12.19 Block Diagram of Timer RD Interrupt

As with other maskable interrupts, the timer RD (channel 0) interrupt, timer RD (channel 1) interrupt, clock synchronous serial I/O with chip select interrupt, and I²C bus interface interrupt are controlled by the combination of the I flag, IR bit, bits ILVL0 to ILVL2, and IPL. However, since each interrupt source is generated by a combination of multiple interrupt request sources, the following differences from other maskable interrupts apply:

- When bits in the enable register corresponding to bits set to 1 in the status register are set to 1 (enable interrupt), the IR bit in the interrupt control register is set to 1 (interrupt requested).
- When either bits in the status register or bits in the enable register corresponding to bits in the status register, or both, are set to 0, the IR bit is set to 0 (interrupt not requested). Basically, even though the interrupt is not acknowledged after the IR bit is set to 1, the interrupt request will not be maintained. Also, the IR bit is not set to 0 even if 0 is written to the IR bit.
- Individual bits in the status register are not automatically set to 0 even if the interrupt is acknowledged. Therefore, the IR bit is also not automatically set to 0 when the interrupt is acknowledged. Set each bit in the status register to 0 in the interrupt routine. Refer to the status register figure for how to set individual bits in the status register to 0.
- When multiple bits in the enable register are set to 1 and other request sources are generated after the IR bit is set to 1, the IR bit remains 1.
- When multiple bits in the enable register are set to 1, determine by the status register which request source causes an interrupt.

Refer to chapters of the individual peripheral functions (**14.3 Timer RD**, **16.2 Clock Synchronous Serial I/O with Chip Select (SSU)** and **16.3 I²C bus Interface**) for the status register and enable register.

Refer to **12.1.6 Interrupt Control** for the interrupt control register.

12.6 Notes on Interrupts

12.6.1 Reading Address 00000h

Do not read address 00000h by a program. When a maskable interrupt request is acknowledged, the CPU reads interrupt information (interrupt number and interrupt request level) from 00000h in the interrupt sequence. At this time, the acknowledged interrupt IR bit is set to 0.

If address 00000h is read by a program, the IR bit for the interrupt which has the highest priority among the enabled interrupts is set to 0. This may cause the interrupt to be canceled, or an unexpected interrupt to be generated.

12.6.2 SP Setting

Set any value in the SP before an interrupt is acknowledged. The SP is set to 0000h after reset. Therefore, if an interrupt is acknowledged before setting a value in the SP, the program may run out of control.

12.6.3 External Interrupt and Key Input Interrupt

Either “L” level or an “H” level of width shown in the Electrical Characteristics is necessary for the signal input to pins $\overline{\text{INT0}}$ to $\overline{\text{INT3}}$ and pins $\overline{\text{KI0}}$ to $\overline{\text{KI3}}$, regardless of the CPU clock.

For details, refer to **Table 20.21** (VCC = 5V), **Table 20.27** (VCC = 3V), **Table 20.33** (VCC = 2.2V) **External Interrupt INT_i (i = 0 to 3) Input**.

12.6.4 Watchdog Timer Interrupt

Reset the watchdog timer after a watchdog timer interrupt is generated.

12.6.5 Changing Interrupt Sources

The IR bit in the interrupt control register may be set to 1 (interrupt requested) when the interrupt source changes. When using an interrupt, set the IR bit to 0 (no interrupt requested) after changing the interrupt source. In addition, changes of interrupt sources include all factors that change the interrupt sources assigned to individual software interrupt numbers, polarities, and timing. Therefore, if a mode change of a peripheral function involves interrupt sources, edge polarities, and timing, set the IR bit to 0 (no interrupt requested) after the change. Refer to the individual peripheral function for its related interrupts.

Figure 12.20 shows an Example of Procedure for Changing Interrupt Sources.

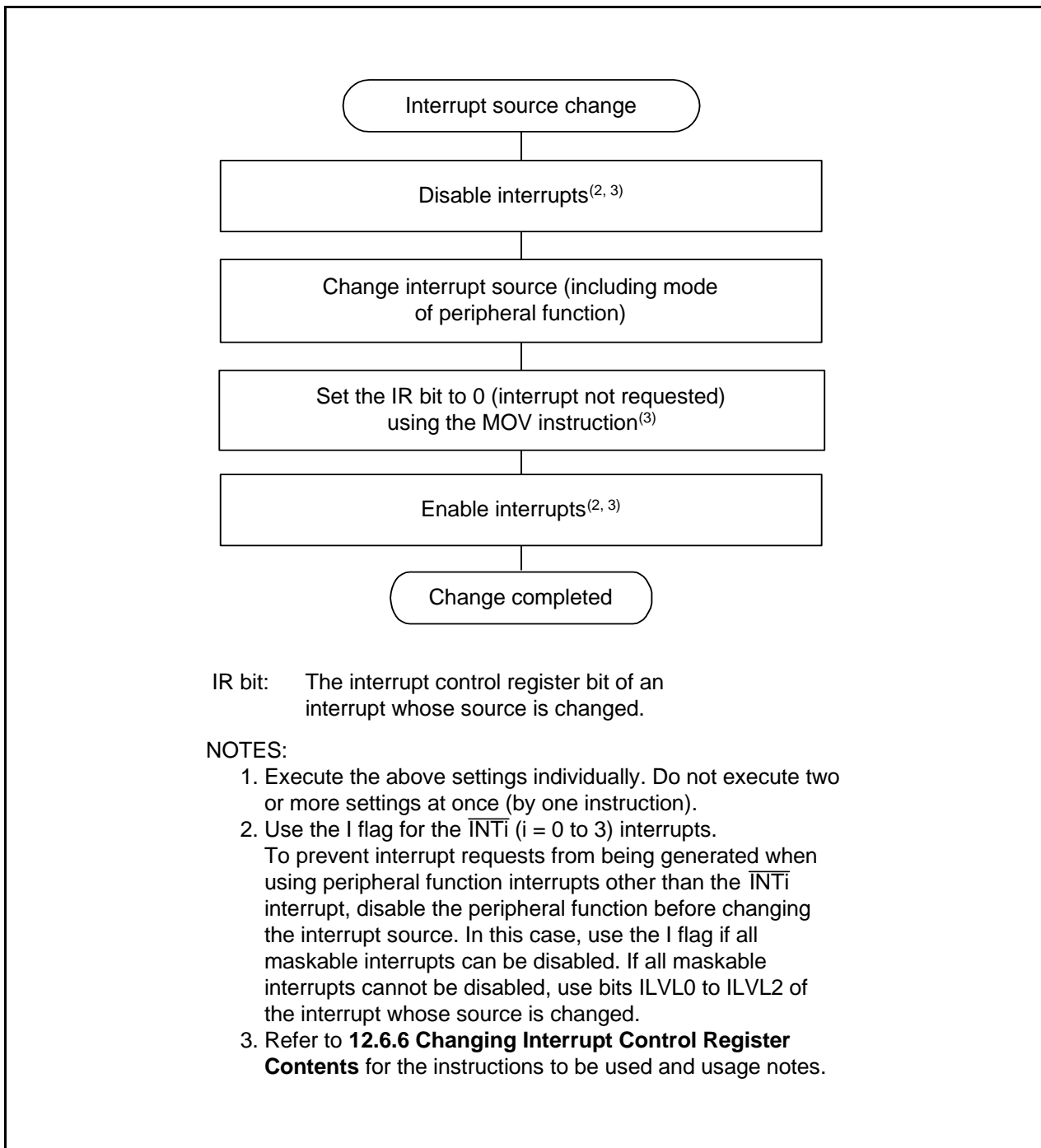

Figure 12.20 Example of Procedure for Changing Interrupt Sources

12.6.6 Changing Interrupt Control Register Contents

- (a) The contents of an interrupt control register can only be changed while no interrupt requests corresponding to that register are generated. If interrupt requests may be generated, disable interrupts before changing the interrupt control register contents.
- (b) When changing the contents of an interrupt control register after disabling interrupts, be careful to choose appropriate instructions.

Changing any bit other than IR bit

If an interrupt request corresponding to a register is generated while executing the instruction, the IR bit may not be set to 1 (interrupt requested), and the interrupt request may be ignored. If this causes a problem, use the following instructions to change the register: AND, OR, BCLR, BSET

Changing IR bit

If the IR bit is set to 0 (interrupt not requested), it may not be set to 0 depending on the instruction used. Therefore, use the MOV instruction to set the IR bit to 0.

- (c) When disabling interrupts using the I flag, set the I flag as shown in the sample programs below. Refer to (b) regarding changing the contents of interrupt control registers by the sample programs.

Sample programs 1 to 3 are for preventing the I flag from being set to 1 (interrupts enabled) before the interrupt control register is changed for reasons of the internal bus or the instruction queue buffer.

Example 1: Use NOP instructions to prevent I flag from being set to 1 before interrupt control register is changed

```
INT_SWITCH1:
  FCLR   I           ; Disable interrupts
  AND.B  #00H,0056H ; Set TRAIC register to 00h
  NOP                    ;
  NOP                    ;
  FSET   I           ; Enable interrupts
```

Example 2: Use dummy read to delay FSET instruction

```
INT_SWITCH2:
  FCLR   I           ; Disable interrupts
  AND.B  #00H,0056H ; Set TRAIC register to 00h
  MOV.W  MEM,R0     ; Dummy read
  FSET   I           ; Enable interrupts
```

Example 3: Use POPC instruction to change I flag

```
INT_SWITCH3:
  PUSHC  FLG
  FCLR   I           ; Disable interrupts
  AND.B  #00H,0056H ; Set TRAIC register to 00h
  POPC   FLG        ; Enable interrupts
```

13. Watchdog Timer

The watchdog timer is a function that detects when a program is out of control. Use of the watchdog timer is recommended to improve the reliability of the system. The watchdog timer contains a 15-bit counter and allows selection of count source protection mode enable or disable.

Table 13.1 lists information on the Count Source Protection Mode.

Refer to **5.6 Watchdog Timer Reset** for details on the watchdog timer.

Figure 13.1 shows the Block Diagram of Watchdog Timer and Figures 13.2 to 13.3 show Registers OFS, WDC, WDTR, WDTS, and CSPR.

Table 13.1 Count Source Protection Mode

Item	Count Source Protection Mode Disabled	Count Source Protection Mode Enabled
Count source	CPU clock	Low-speed on-chip oscillator clock
Count operation	Decrement	
Count start condition	Either of the following can be selected <ul style="list-style-type: none"> • After reset, count starts automatically • Count starts by writing to WDTS register 	
Count stop condition	Stop mode, wait mode	None
Reset condition of watchdog timer	<ul style="list-style-type: none"> • Reset • Write 00h to the WDTR register before writing FFh • Underflow 	
Operation at the time of underflow	Watchdog timer interrupt or watchdog timer reset	Watchdog timer reset

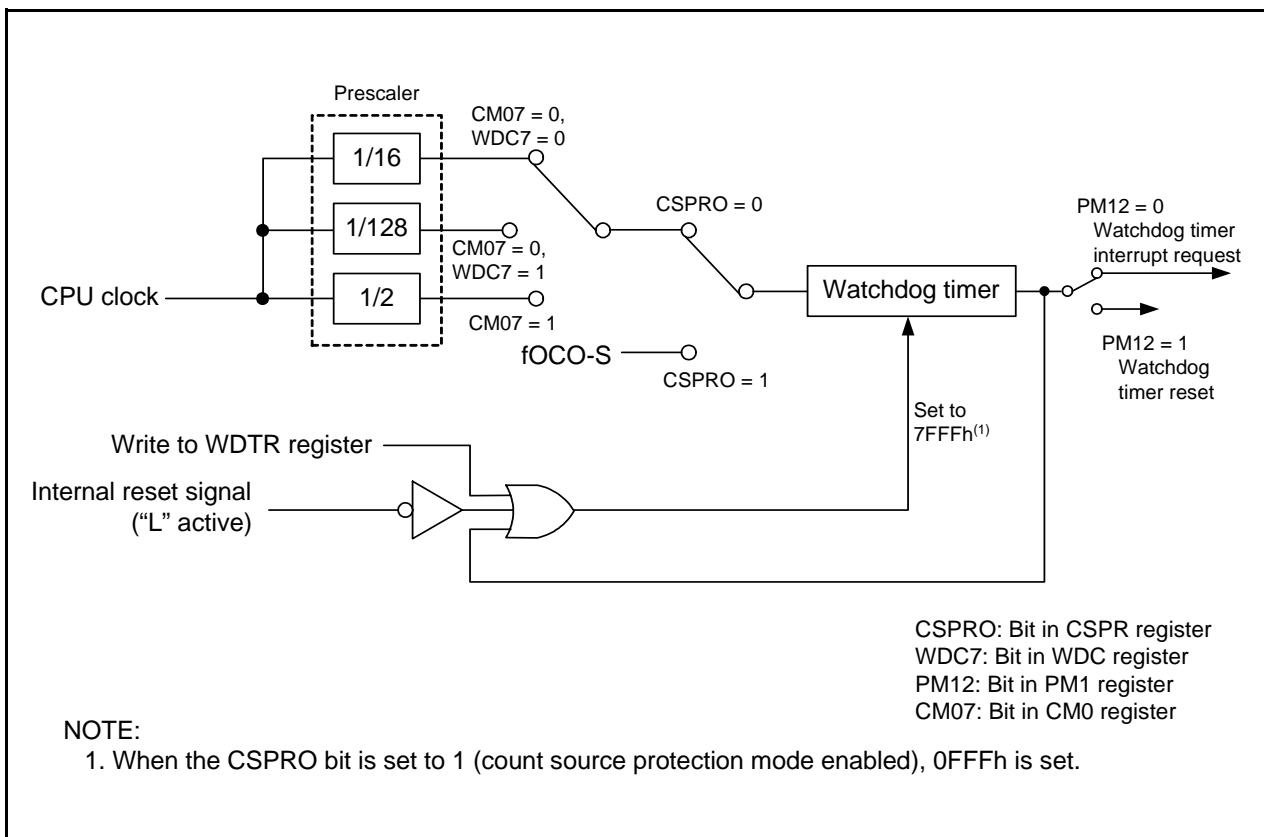

Figure 13.1 Block Diagram of Watchdog Timer

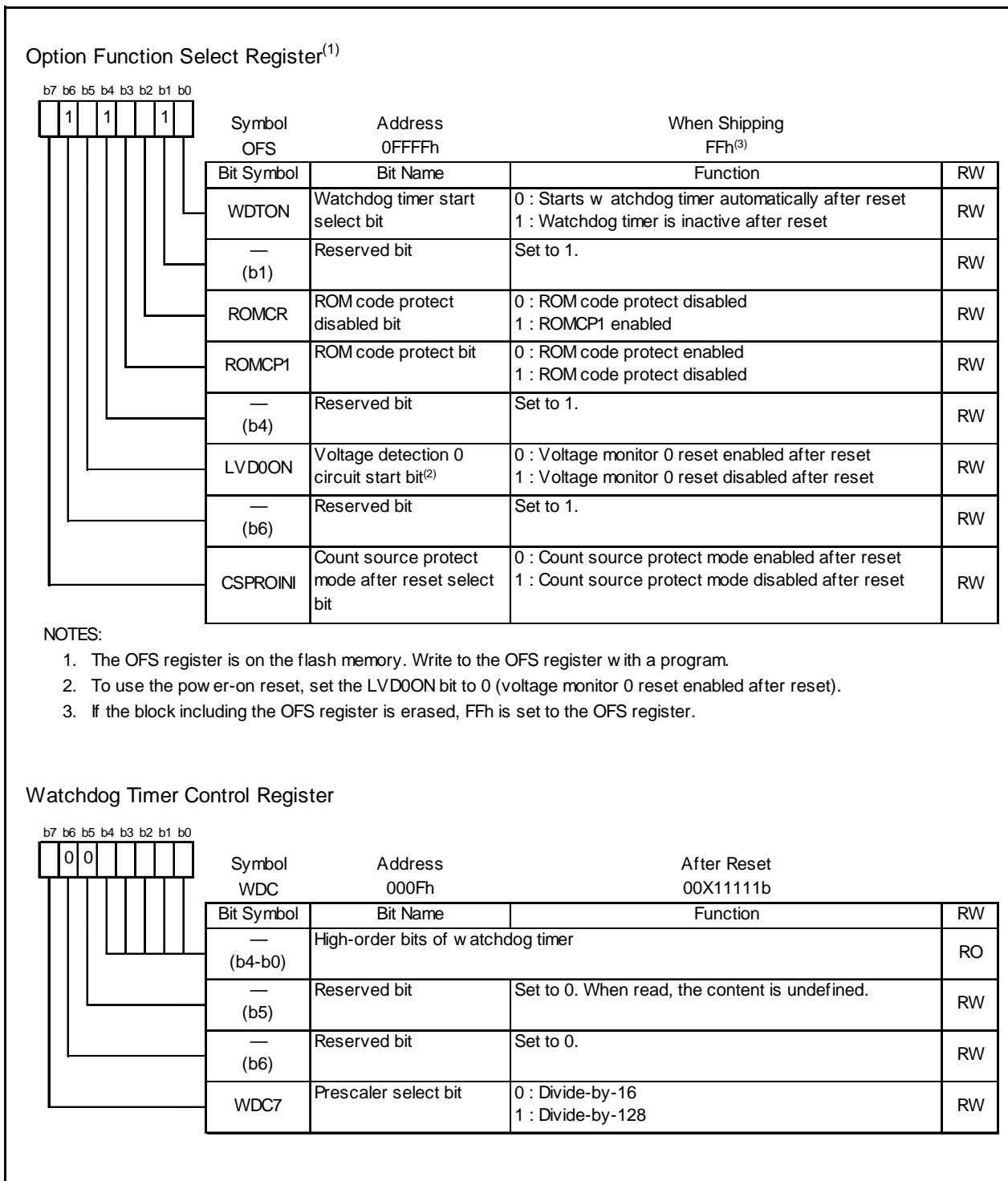

Figure 13.2 Registers OFS and WDC

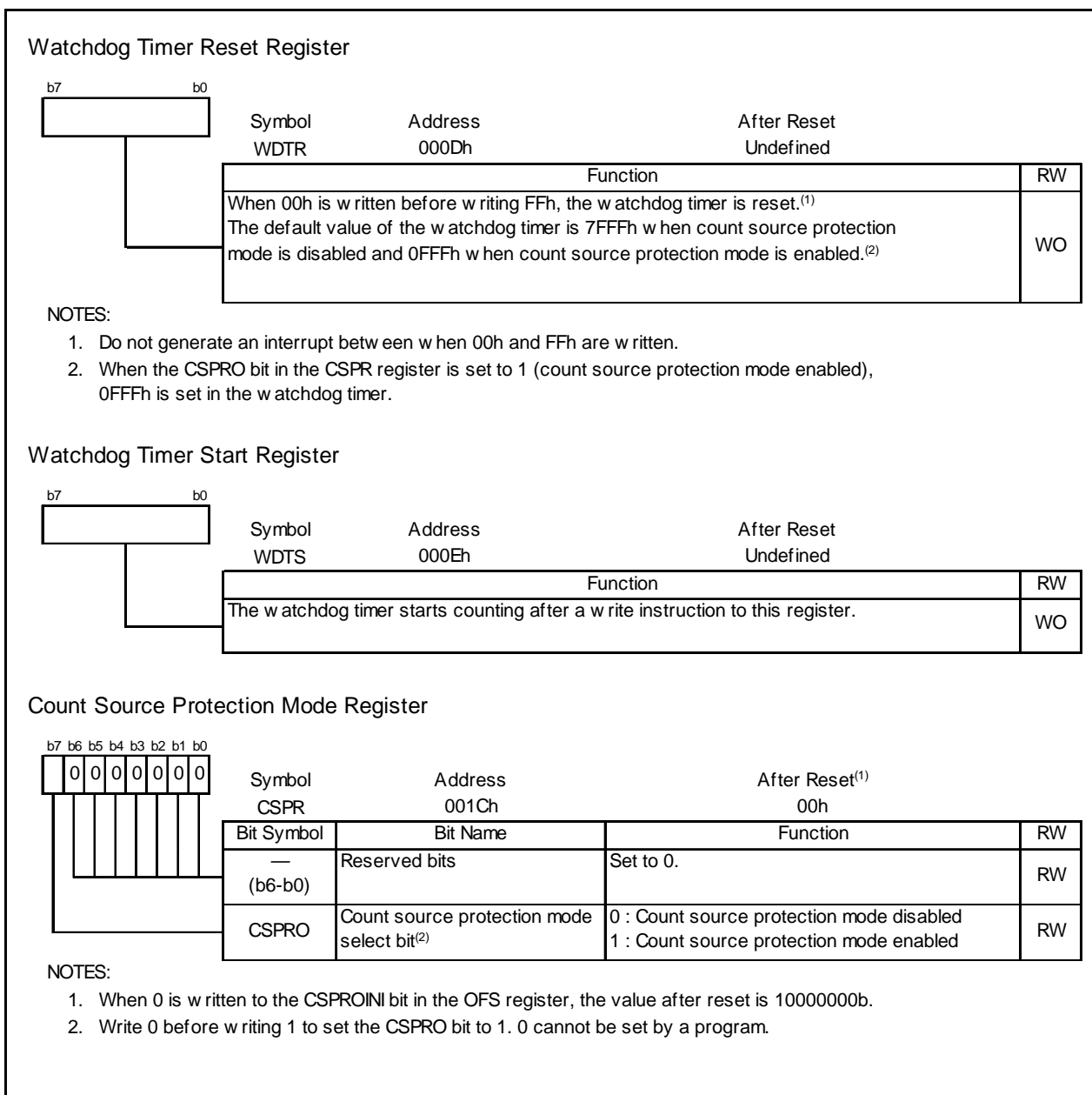

Figure 13.3 Registers WDTR, WDTS, and CSPR

13.1 Count Source Protection Mode Disabled

The count source of the watchdog timer is the CPU clock when count source protection mode is disabled. Table 13.2 lists the Watchdog Timer Specifications (with Count Source Protection Mode Disabled).

Table 13.2 Watchdog Timer Specifications (with Count Source Protection Mode Disabled)

Item	Specification
Count source	CPU clock
Count operation	Decrement
Period	$\text{Division ratio of prescaler (n) } \times \text{ count value of watchdog timer (32768)}^{(1)}$ CPU clock n: 16 or 128 (selected by WDC7 bit in WDC register) Example: When the CPU clock frequency is 16 MHz and prescaler divided by 16, the period is approximately 32.8 ms
Count start condition	The WDTON bit ⁽²⁾ in the OFS register (0FFFFh) selects the operation of the watchdog timer after a reset <ul style="list-style-type: none"> When the WDTON bit is set to 1 (watchdog timer is in stop state after reset) The watchdog timer and prescaler stop after a reset and the count starts when the WDTS register is written to When the WDTON bit is set to 0 (watchdog timer starts automatically after exiting) The watchdog timer and prescaler start counting automatically after a reset
Reset condition of watchdog timer	<ul style="list-style-type: none"> Reset Write 00h to the WDTR register before writing FFh Underflow
Count stop condition	Stop and wait modes (inherit the count from the held value after exiting modes)
Operation at time of underflow	<ul style="list-style-type: none"> When the PM12 bit in the PM1 register is set to 0 Watchdog timer interrupt When the PM12 bit in the PM1 register is set to 1 Watchdog timer reset (refer to 5.6 Watchdog Timer Reset)

NOTES:

- The watchdog timer is reset when 00h is written to the WDTR register before FFh. The prescaler is reset after the MCU is reset. Some errors in the period of the watchdog timer may be caused by the prescaler.
- The WDTON bit cannot be changed by a program. To set the WDTON bit, write 0 to bit 0 of address 0FFFFh with a flash programmer.

13.2 Count Source Protection Mode Enabled

The count source of the watchdog timer is the low-speed on-chip oscillator clock when count source protection mode is enabled. If the CPU clock stops when a program is out of control, the clock can still be supplied to the watchdog timer.

Table 13.3 lists the Watchdog Timer Specifications (with Count Source Protection Mode Enabled).

Table 13.3 Watchdog Timer Specifications (with Count Source Protection Mode Enabled)

Item	Specification
Count source	Low-speed on-chip oscillator clock
Count operation	Decrement
Period	Count value of watchdog timer (4096) Low-speed on-chip oscillator clock Example: Period is approximately 32.8 ms when the low-speed on-chip oscillator clock frequency is 125 kHz
Count start condition	The WDTON bit ⁽¹⁾ in the OFS register (0FFFFh) selects the operation of the watchdog timer after a reset. <ul style="list-style-type: none"> When the WDTON bit is set to 1 (watchdog timer is in stop state after reset) The watchdog timer and prescaler stop after a reset and the count starts when the WDTS register is written to When the WDTON bit is set to 0 (watchdog timer starts automatically after reset) The watchdog timer and prescaler start counting automatically after a reset
Reset condition of watchdog timer	<ul style="list-style-type: none"> Reset Write 00h to the WDTR register before writing FFh Underflow
Count stop condition	None (The count does not stop in wait mode after the count starts. The MCU does not enter stop mode.)
Operation at time of underflow	Watchdog timer reset (Refer to 5.6 Watchdog Timer Reset.)
Registers, bits	<ul style="list-style-type: none"> When setting the CSPPRO bit in the CSPR register to 1 (count source protection mode is enabled)⁽²⁾, the following are set automatically <ul style="list-style-type: none"> Set 0FFFh to the watchdog timer Set the CM14 bit in the CM1 register to 0 (low-speed on-chip oscillator on) Set the PM12 bit in the PM1 register to 1 (The watchdog timer is reset when watchdog timer underflows) The following conditions apply in count source protection mode <ul style="list-style-type: none"> Writing to the CM10 bit in the CM1 register is disabled (It remains unchanged even if it is set to 1. The MCU does not enter stop mode.) Writing to the CM14 bit in the CM1 register is disabled (It remains unchanged even if it is set to 1. The low-speed on-chip oscillator does not stop.)

NOTES:

- The WDTON bit cannot be changed by a program. To set the WDTON bit, write 0 to bit 0 of address 0FFFFh with a flash programmer.
- Even if 0 is written to the CSPROINI bit in the OFS register, the CSPRO bit is set to 1. The CSPROINI bit cannot be changed by a program. To set the CSPROINI bit, write 0 to bit 7 of address 0FFFFh with a flash programmer.

14. Timers

The MCU has two 8-bit timers with 8-bit prescalers, two 16-bit timers, and a timer with a 4-bit counter and an 8-bit counter. The two 8-bit timers with 8-bit prescalers are timer RA and timer RB. These timers contain a reload register to store the default value of the counter. The 16-bit timer is timer RD, and has input capture and output compare functions. The 4 and 8-bit counters are timer RE, and has an output compare function. All the timers operate independently.

Table 14.1 lists Functional Comparison of Timers.

Table 14.1 Functional Comparison of Timers

Item		Timer RA	Timer RB	Timer RD	Timer RE
Configuration		8-bit timer with 8-bit prescaler (with reload register)	8-bit timer with 8-bit prescaler (with reload register)	16-bit free-run timer × 2 (with input capture and output compare)	4-bit counter 8-bit counter
Count		Decrement	Decrement	Increment/Decrement	Increment
Count sources		<ul style="list-style-type: none"> • f1 • f2 • f8 • fOCO • fC32 	<ul style="list-style-type: none"> • f1 • f2 • f8 • Timer RA underflow 	<ul style="list-style-type: none"> • f1 • f2 • f4 • f8 • f32 • fOCO40M • TRDIOA0 	<ul style="list-style-type: none"> • f4 • f8 • f32 • fC4 • fC32
Function	Timer mode	Provided	Provided	Provided (input capture function, output compare function)	Not provided
	Pulse output mode	Provided	Not provided	Not provided	Not provided
	Event counter mode	Provided	Not provided	Not provided	Not provided
	Pulse width measurement mode	Provided	Not provided	Not provided	Not provided
	Pulse period measurement mode	Provided	Not provided	Not provided	Not provided
	Programmable waveform generation mode	Not provided	Provided	Not provided	Not provided
	Programmable one-shot generation mode	Not provided	Provided	Not provided	Not provided
	Programmable wait one-shot generation mode	Not provided	Provided	Not provided	Not provided
	Input capture mode	Not provided	Not provided	Provided	Not provided
	Output compare mode	Not provided	Not provided	Provided	Provided
	PWM mode	Not provided	Not provided	Provided	Not provided
	Reset synchronized PWM mode	Not provided	Not provided	Provided	Not provided
	Complementary PWM mode	Not provided	Not provided	Provided	Not provided
	PWM3 mode	Not provided	Not provided	Provided	Not provided
Real-time clock mode	Not provided	Not provided	Not provided	Provided	
Input pin		TRAIO	INT0	INT0, TRDCLK, TRDIOA0, TRDIOA1, TRDIOB0, TRDIOB1, TRDIOC0, TRDIOC1, TRDIOD0, TRDIOD1	-
Output pin		TRA0 TRAIO	TRB0	TRDIOA0, TRDIOA1, TRDIOB0, TRDIOB1, TRDIOC0, TRDIOC1, TRDIOD0, TRDIOD1	TRE0
Related interrupt		Timer RA interrupt INT1 interrupt	Timer RB interrupt INT0 interrupt	Compare match/input Capture A0 to D0 interrupt Compare match/input Capture A1 to D1 interrupt Overflow interrupt Underflow interrupt ⁽¹⁾ INT0 interrupt	Timer RE interrupt
Timer stop		Provided	Provided	Provided	Provided

NOTE:

1. The underflow interrupt can be set to channel 1.

14.1 Timer RA

Timer RA is an 8-bit timer with an 8-bit prescaler.

The prescaler and timer each consist of a reload register and counter. The reload register and counter are allocated at the same address, and can be accessed when accessing registers TRAPRE and TRA (refer to **Tables 14.2 to 14.6 the Specifications of Each Mode**).

The count source for timer RA is the operating clock that regulates the timing of timer operations such as counting and reloading.

Figure 14.1 shows a Block Diagram of Timer RA. Figures 14.2 and 14.3 show the registers associated with Timer RA.

Timer RA has the following five operating modes:

- Timer mode: The timer counts the internal count source.
- Pulse output mode: The timer counts the internal count source and outputs pulses of which polarity inverted by underflow of the timer.
- Event counter mode: The timer counts external pulses.
- Pulse width measurement mode: The timer measures the pulse width of an external pulse.
- Pulse period measurement mode: The timer measures the pulse period of an external pulse.

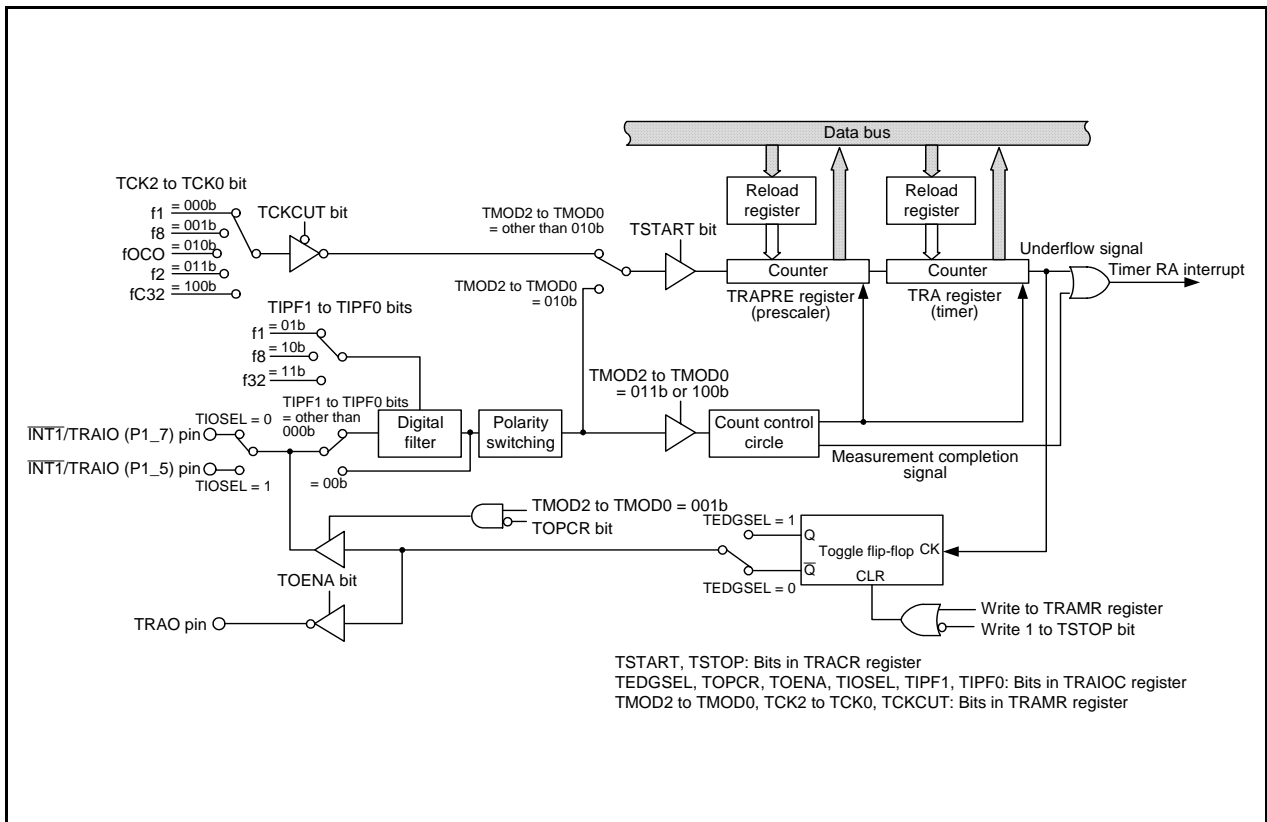

Figure 14.1 Block Diagram of Timer RA

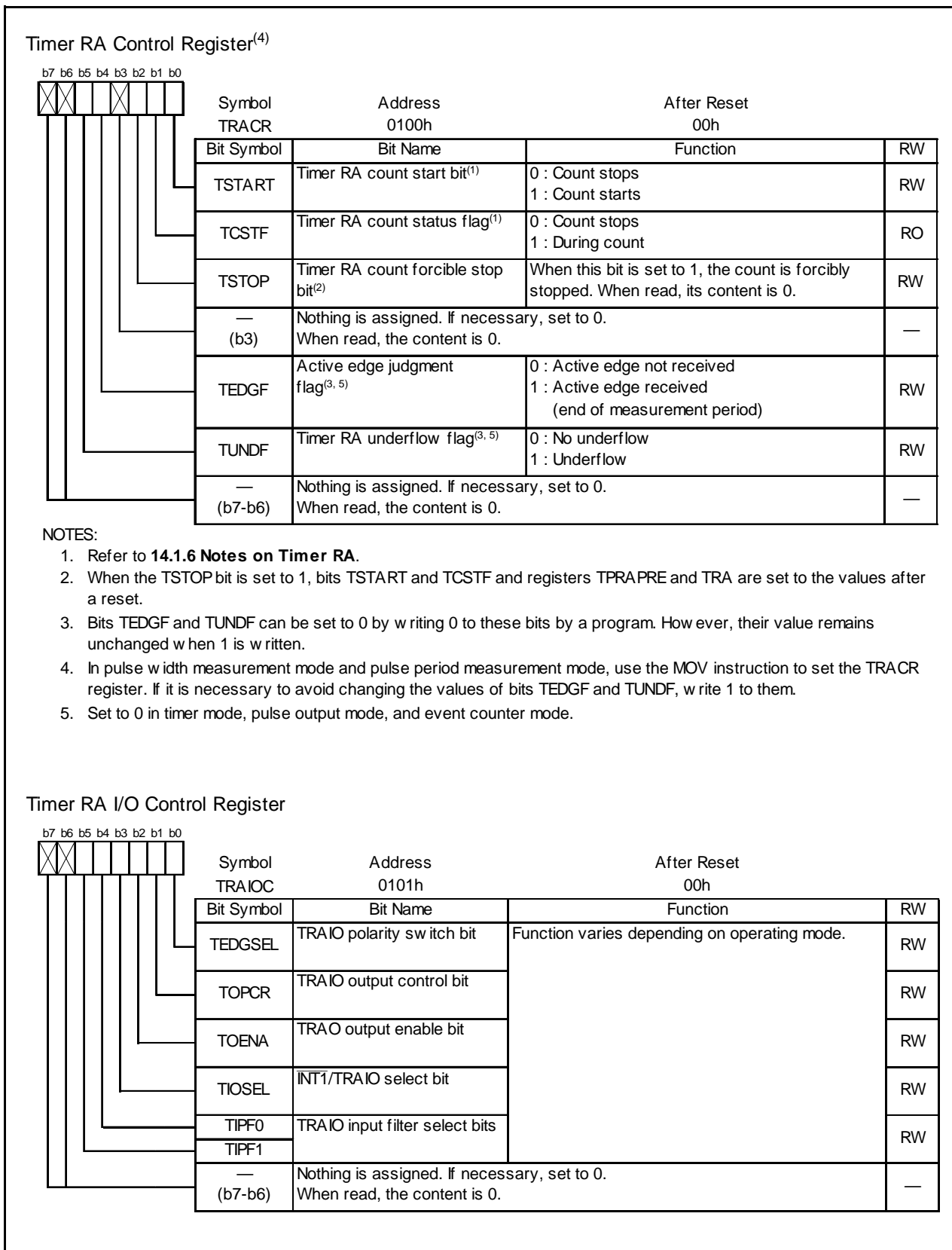

Figure 14.2 Registers TRACR and TRAI0C

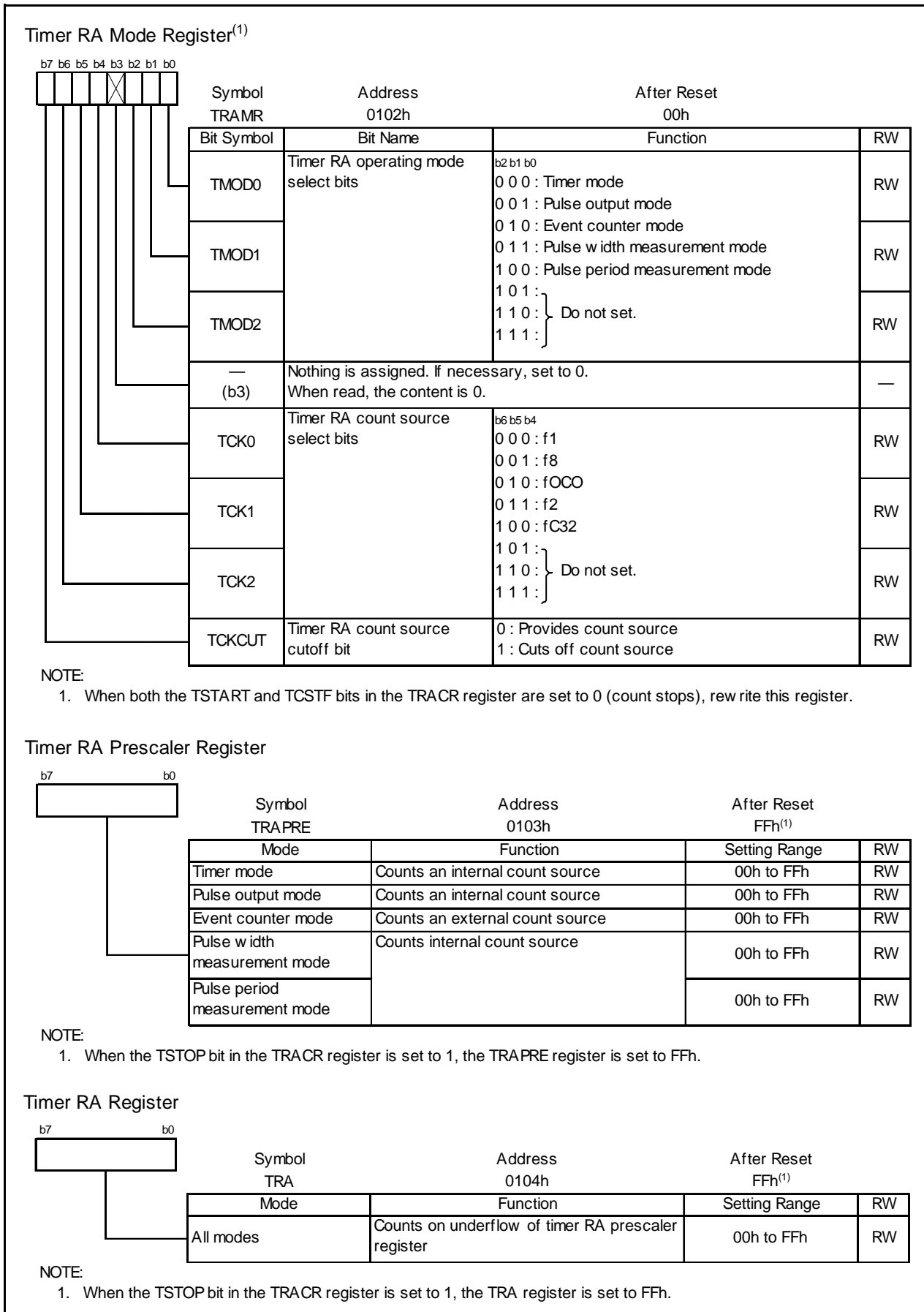

Figure 14.3 Registers TRAMR, TRAPRE, and TRA

14.1.1 Timer Mode

In this mode, the timer counts an internally generated count source (refer to **Table 14.2 Timer Mode Specifications**).

Figure 14.4 shows TRAIOC Register in Timer Mode.

Table 14.2 Timer Mode Specifications

Item	Specification
Count sources	f1, f2, f8, fOCO, fC32
Count operations	<ul style="list-style-type: none"> Decrement When the timer underflows, the contents of the reload register are reloaded and the count is continued.
Divide ratio	$1/(n+1)(m+1)$ n: Value set in TRAPRE register, m: Value set in TRA register
Count start condition	1 (count starts) is written to the TSTART bit in the TRACR register.
Count stop conditions	<ul style="list-style-type: none"> 0 (count stops) is written to the TSTART bit in the TRACR register. 1 (count forcibly stops) is written to the TSTOP bit in the TRACR register.
Interrupt request generation timing	When timer RA underflows [timer RA interrupt].
INT1/TRAI0 pin function	Programmable I/O port, or INT1 interrupt input
TRAO pin function	Programmable I/O port
Read from timer	The count value can be read by reading registers TRA and TRAPRE.
Write to timer	<ul style="list-style-type: none"> When registers TRAPRE and TRA are written while the count is stopped, values are written to both the reload register and counter. When registers TRAPRE and TRA are written during the count, values are written to the reload register and counter (refer to 14.1.1.1 Timer Write Control during Count Operation).

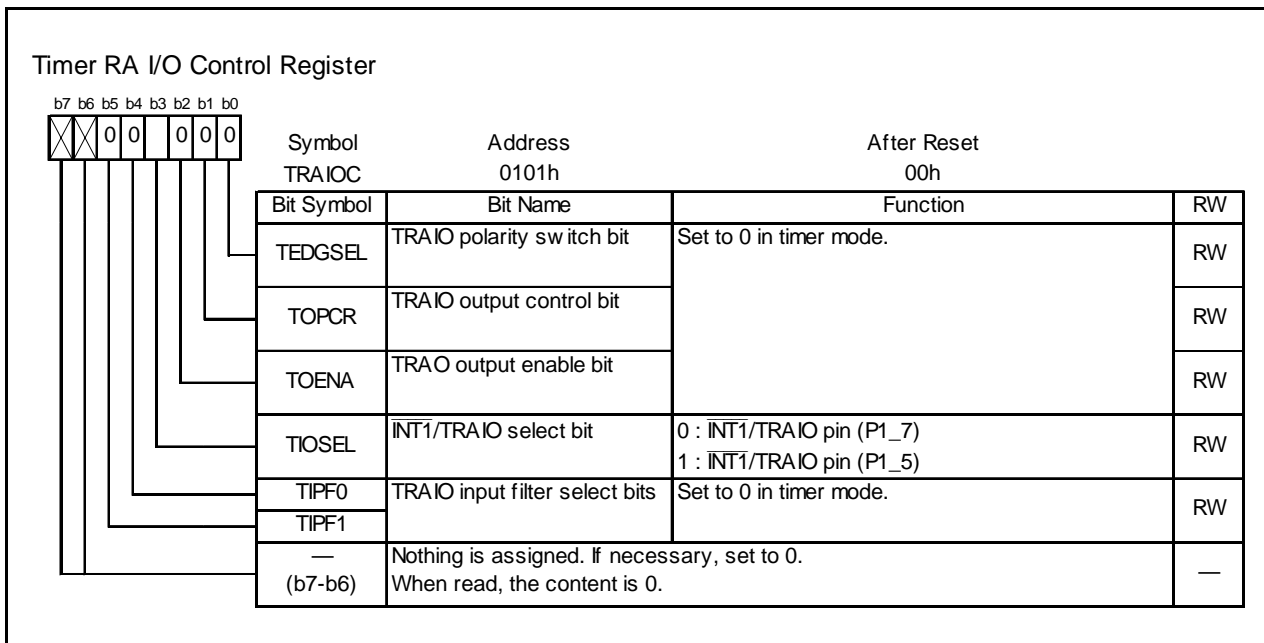

Figure 14.4 TRAI0C Register in Timer Mode

14.1.1.1 Timer Write Control during Count Operation

Timer RA has a prescaler and a timer (which counts the prescaler underflows). The prescaler and timer each consist of a reload register and a counter. When writing to the prescaler or timer, values are written to both the reload register and counter.

However, values are transferred from the reload register to the counter of the prescaler in synchronization with the count source. In addition, values are transferred from the reload register to the counter of the timer in synchronization with prescaler underflows. Therefore, if the prescaler or timer is written to when count operation is in progress, the counter value is not updated immediately after the WRITE instruction is executed. Figure 14.5 shows an Operating Example of Timer RA when Counter Value is Rewritten during Count Operation.

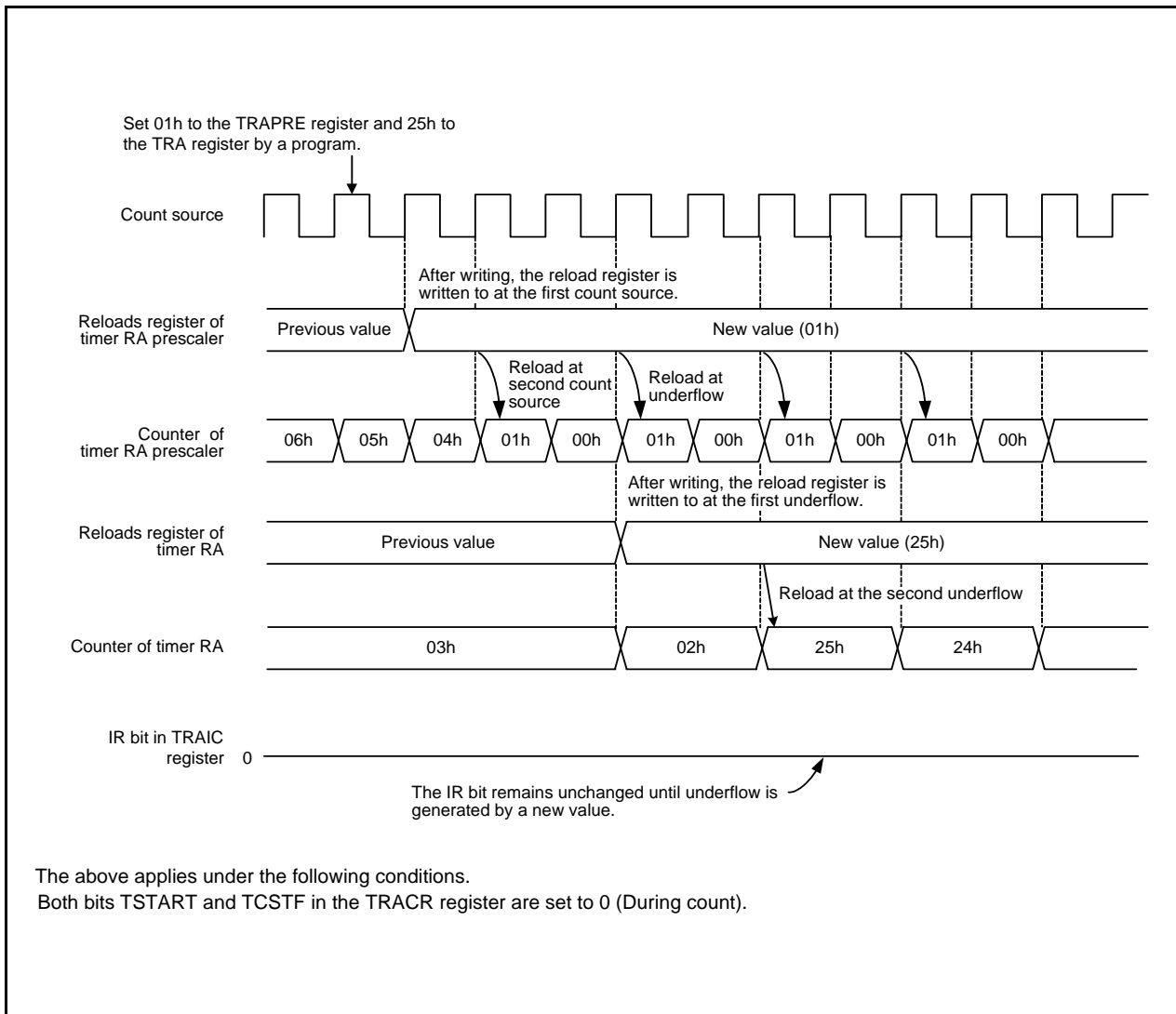

Figure 14.5 Operating Example of Timer RA when Counter Value is Rewritten during Count Operation

14.1.2 Pulse Output Mode

In pulse output mode, the internally generated count source is counted, and a pulse with inverted polarity is output from the TRAI0 pin each time the timer underflows (refer to **Table 14.3 Pulse Output Mode Specifications**).

Figure 14.6 shows TRAI0C Register in Pulse Output Mode.

Table 14.3 Pulse Output Mode Specifications

Item	Specification
Count sources	f1, f2, f8, fOCO, fC32
Count operations	<ul style="list-style-type: none"> • Decrement • When the timer underflows, the contents in the reload register is reloaded and the count is continued.
Divide ratio	$1/(n+1)(m+1)$ n: Value set in TRAPRE register, m: Value set in TRA register
Count start condition	1 (count starts) is written to the TSTART bit in the TRACR register.
Count stop conditions	<ul style="list-style-type: none"> • 0 (count stops) is written to the TSTART bit in the TRACR register. • 1 (count forcibly stops) is written to the TSTOP bit in the TRACR register.
Interrupt request generation timing	When timer RA underflows [timer RA interrupt].
INT1/TRAI0 pin function	Pulse output, programmable output port, or INT1 interrupt ⁽¹⁾
TRAO pin function	Programmable I/O port or inverted output of TRAI0 ⁽¹⁾
Read from timer	The count value can be read by reading registers TRA and TRAPRE.
Write to timer	<ul style="list-style-type: none"> • When registers TRAPRE and TRA are written while the count is stopped, values are written to both the reload register and counter. • When registers TRAPRE and TRA are written during the count, values are written to the reload register and counter (refer to 14.1.1.1 Timer Write Control during Count Operation).
Select functions	<ul style="list-style-type: none"> • TRAI0 output polarity switch function The TEDGSEL bit in the TRAI0C register selects the level at the start of pulse output.⁽¹⁾ • TRAO output function Pulses inverted from the TRAI0 output polarity can be output from the TRAO pin (selectable by the TOENA bit in the TRAI0C register). • Pulse output stop function Output from the TRAI0 pin is stopped by the TOPCR bit in the TRAI0C register. • INT1/TRAI0 pin select function P1_7 or P1_5 is selected by the TIOSEL bit in the TRAI0C register.

NOTE:

1. The level of the output pulse becomes the level when the pulse output starts when the TRAMR register is written to.

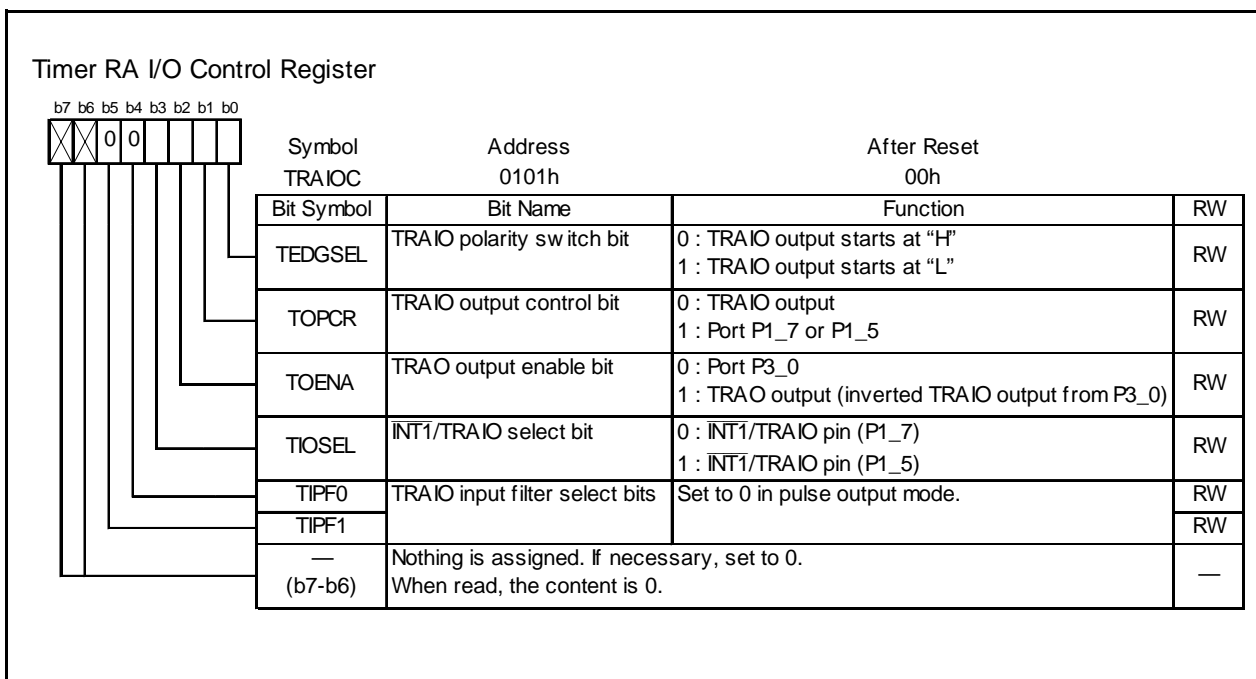

Figure 14.6 TRAI0C Register in Pulse Output Mode

14.1.3 Event Counter Mode

In event counter mode, external signal inputs to the $\overline{\text{INT1}}$ /TRAIO pin are counted (refer to **Table 14.4 Event Counter Mode Specifications**).

Figure 14.7 shows TRAI0C Register in Event Counter Mode.

Table 14.4 Event Counter Mode Specifications

Item	Specification
Count source	External signal which is input to TRAIO pin (active edge selectable by a program)
Count operations	<ul style="list-style-type: none"> • Decrement • When the timer underflows, the contents of the reload register are reloaded and the count is continued.
Divide ratio	$1/(n+1)(m+1)$ n: setting value of TRAPRE register, m: setting value of TRA register
Count start condition	1 (count starts) is written to the TSTART bit in the TRACR register.
Count stop conditions	<ul style="list-style-type: none"> • 0 (count stops) is written to the TSTART bit in the TRACR register. • 1 (count forcibly stops) is written to the TSTOP bit in the TRACR register.
Interrupt request generation timing	<ul style="list-style-type: none"> • When timer RA underflows [timer RA interrupt].
$\overline{\text{INT1}}$ /TRAIO pin function	Count source input ($\overline{\text{INT1}}$ interrupt input)
TRA0 pin function	Programmable I/O port or pulse output ⁽¹⁾
Read from timer	The count value can be read by reading registers TRA and TRAPRE.
Write to timer	<ul style="list-style-type: none"> • When registers TRAPRE and TRA are written while the count is stopped, values are written to both the reload register and counter. • When registers TRAPRE and TRA are written during the count, values are written to the reload register and counter (refer to 14.1.1.1 Timer Write Control during Count Operation).
Select functions	<ul style="list-style-type: none"> • $\overline{\text{NT1}}$ input polarity switch function The TEDGSEL bit in the TRAI0C register selects the active edge of the count source. • Count source input pin select function P1_7 or P1_5 is selected by the TIOSEL bit in the TRAI0C register. • Pulse output function Pulses of inverted polarity can be output from the TRA0 pin each time the timer underflows (selectable by the TOENA bit in the TRAI0C register).⁽¹⁾ • Digital filter function Bits TIPF0 and TIPF1 in the TRAI0C register enable or disable the digital filter and select the sampling frequency.

NOTE:

1. The level of the output pulse becomes the level when the pulse output starts when the TRAMR register is written to.

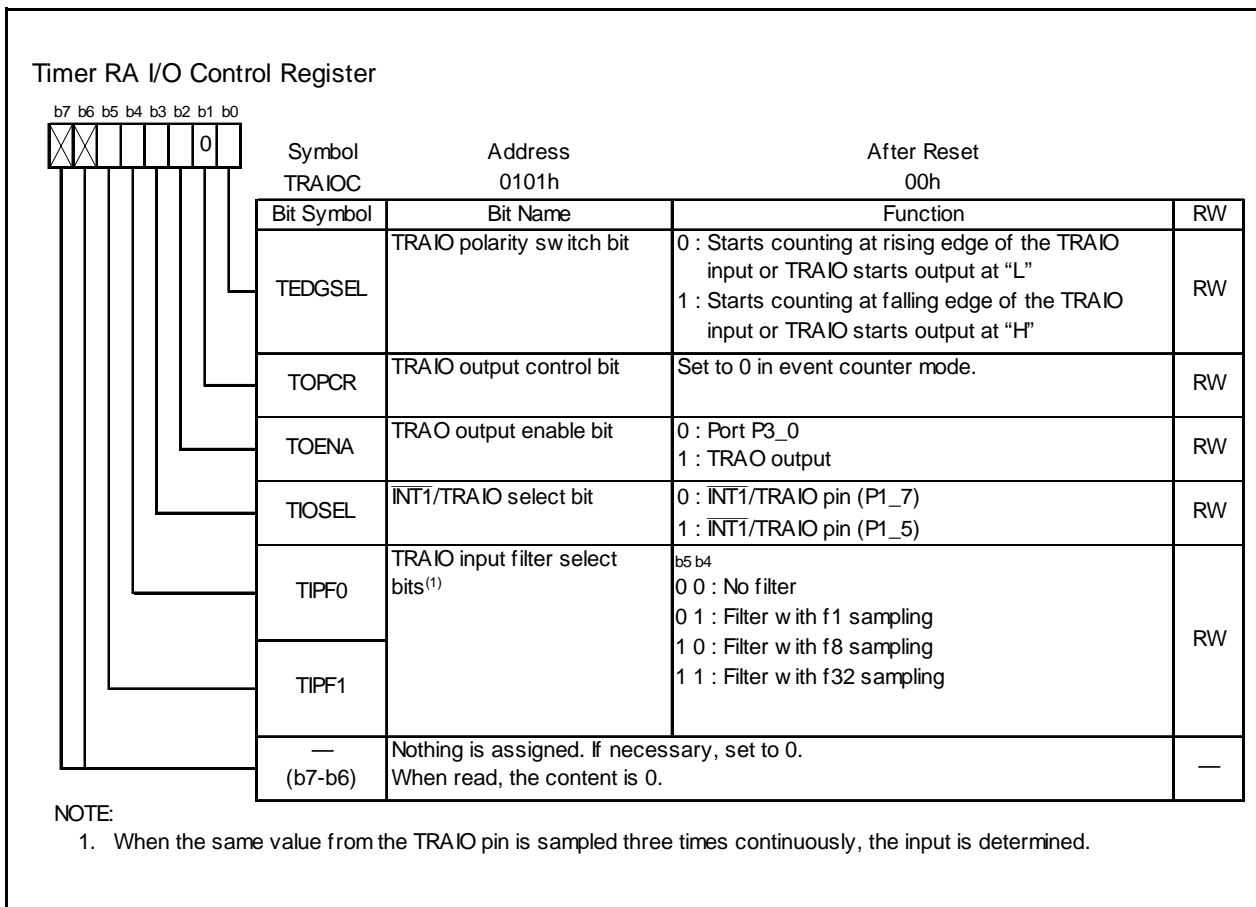

Figure 14.7 TRAI0C Register in Event Counter Mode

14.1.4 Pulse Width Measurement Mode

In pulse width measurement mode, the pulse width of an external signal input to the $\overline{\text{INT1}}$ /TRAIO pin is measured (refer to **Table 14.5 Pulse Width Measurement Mode Specifications**).

Figure 14.8 shows TRAI0C Register in Pulse Width Measurement Mode and Figure 14.9 shows an Operating Example of Pulse Width Measurement Mode.

Table 14.5 Pulse Width Measurement Mode Specifications

Item	Specification
Count sources	f1, f2, f8, fOCO, fC32
Count operations	<ul style="list-style-type: none"> • Decrement • Continuously counts the selected signal only when measurement pulse is “H” level, or conversely only “L” level. • When the timer underflows, the contents of the reload register are reloaded and the count is continued.
Count start condition	1 (count starts) is written to the TSTART bit in the TRACR register.
Count stop conditions	<ul style="list-style-type: none"> • 0 (count stops) is written to the TSTART bit in the TRACR register. • 1 (count forcibly stops) is written to the TSTOP bit in the TRACR register.
Interrupt request generation timing	<ul style="list-style-type: none"> • When timer RA underflows [timer RA interrupt]. • Rising or falling of the TRAIO input (end of measurement period) [timer RA interrupt]
$\overline{\text{INT1}}$ /TRAIO pin function	Measured pulse input ($\overline{\text{INT1}}$ interrupt input)
TRA0 pin function	Programmable I/O port
Read from timer	The count value can be read by reading registers TRA and TRAPRE.
Write to timer	<ul style="list-style-type: none"> • When registers TRAPRE and TRA are written while the count is stopped, values are written to both the reload register and counter. • When registers TRAPRE and TRA are written during the count, values are written to the reload register and counter (refer to 14.1.1.1 Timer Write Control during Count Operation).
Select functions	<ul style="list-style-type: none"> • Measurement level select • The TEDGSEL bit in the TRAI0C register selects the “H” or “L” level period. • Measured pulse input pin select function P1_7 or P1_5 is selected by the TIOSEL bit in the TRAI0C register. • Digital filter function Bits TIPF0 and TIPF1 in the TRAI0C register enable or disable the digital filter and select the sampling frequency.

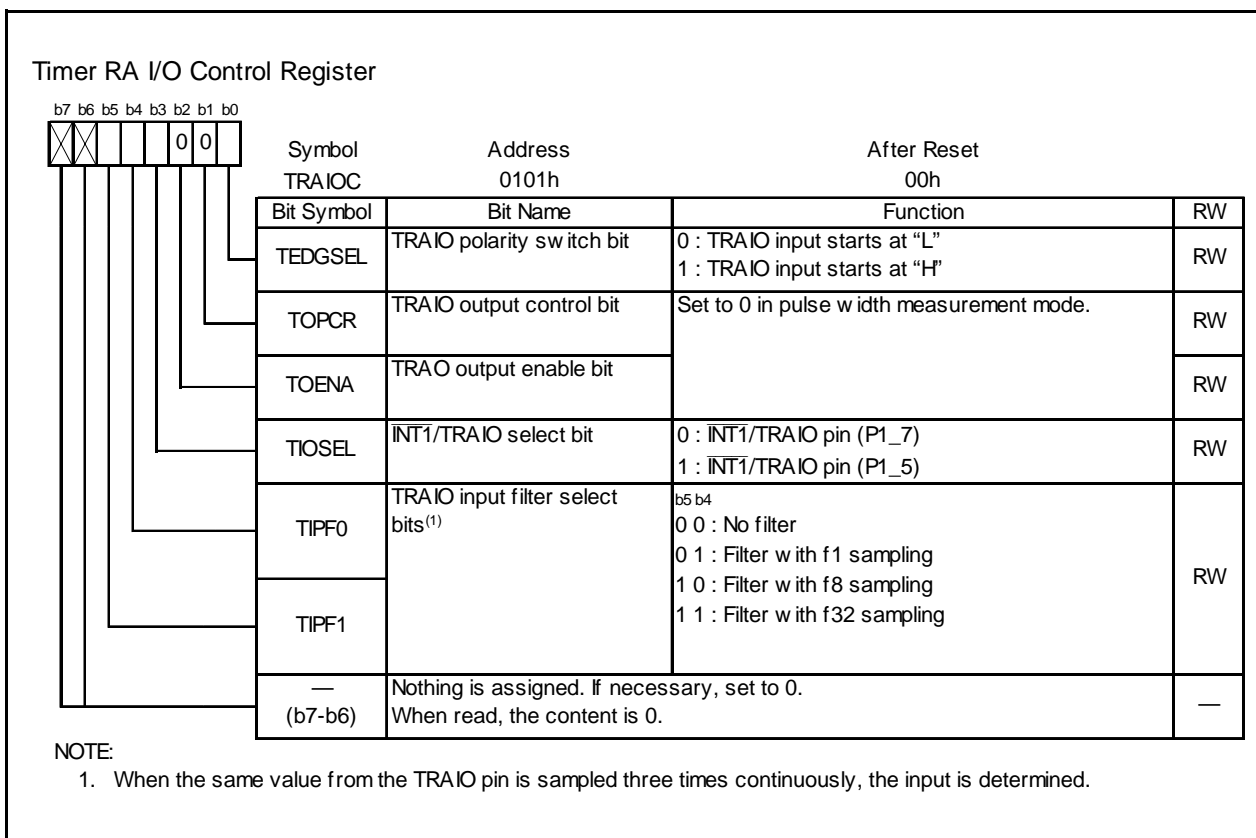

Figure 14.8 TRAI0C Register in Pulse Width Measurement Mode

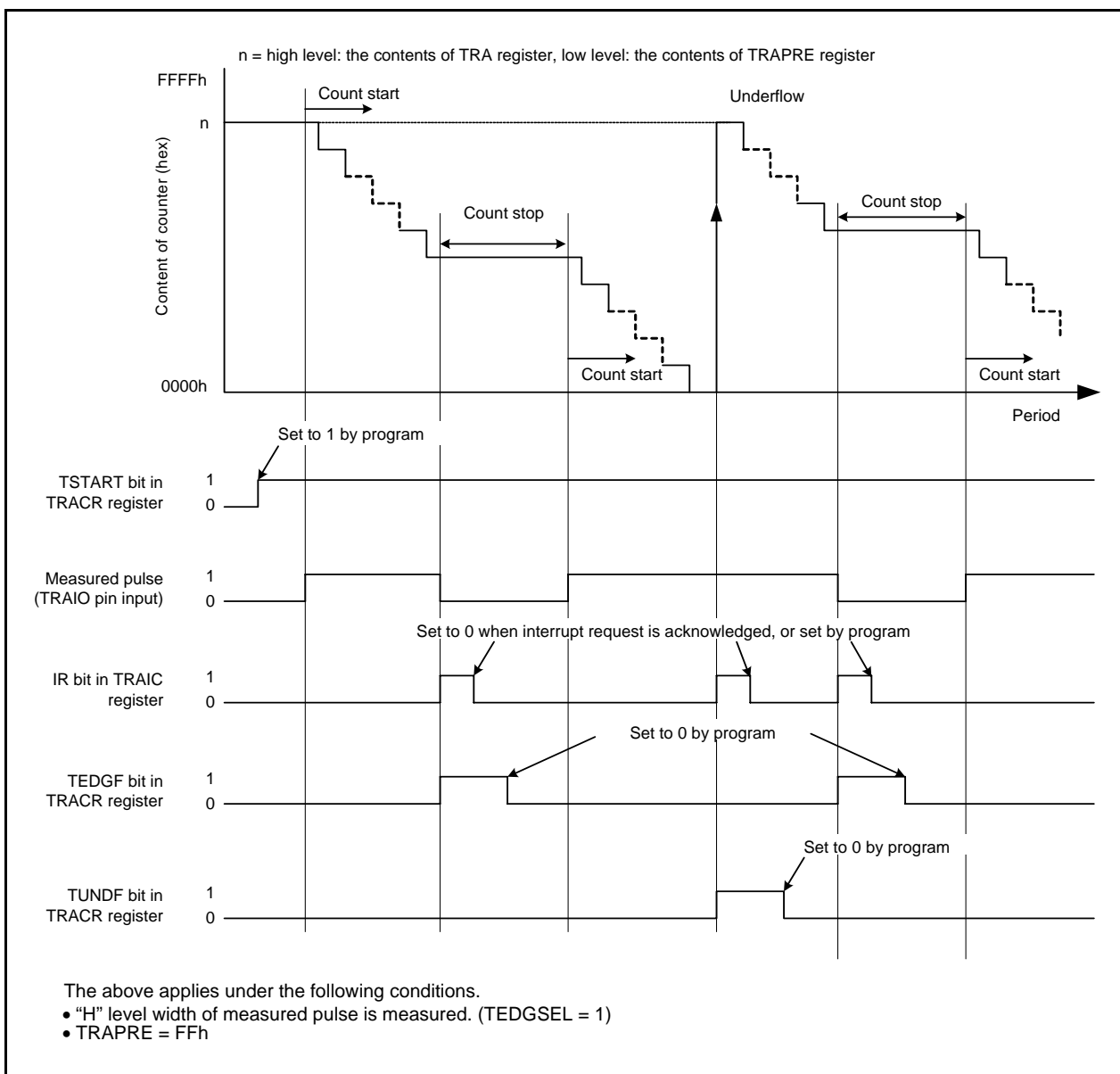

Figure 14.9 Operating Example of Pulse Width Measurement Mode

14.1.5 Pulse Period Measurement Mode

In pulse period measurement mode, the pulse period of an external signal input to the $\overline{\text{INT1}}$ /TRAIO pin is measured (refer to **Table 14.6 Pulse Period Measurement Mode Specifications**).

Figure 14.10 shows TRAIOC Register in Pulse Period Measurement Mode and Figure 14.11 shows an Operating Example of Pulse Period Measurement Mode.

Table 14.6 Pulse Period Measurement Mode Specifications

Item	Specification
Count sources	f1, f2, f8, fOCO, fC32
Count operations	<ul style="list-style-type: none"> • Decrement • After the active edge of the measured pulse is input, the contents of the read-out buffer are retained at the first underflow of timer RA prescaler. Then timer RA reloads the contents in the reload register at the second underflow of timer RA prescaler and continues counting.
Count start condition	1 (count starts) is written to the TSTART bit in the TRACR register.
Count stop conditions	<ul style="list-style-type: none"> • 0 (count stops) is written to TSTART bit in the TRACR register. • 1 (count forcibly stops) is written to the TSTOP bit in the TRACR register.
Interrupt request generation timing	<ul style="list-style-type: none"> • When timer RA underflows or reloads [timer RA interrupt]. • Rising or falling of the TRAIO input (end of measurement period) [timer RA interrupt]
$\overline{\text{INT1}}$ /TRAIO pin function	Measured pulse input ⁽¹⁾ ($\overline{\text{INT1}}$ interrupt input)
TRAIO pin function	Programmable I/O port
Read from timer	The count value can be read by reading registers TRA and TRAPRE.
Write to timer	<ul style="list-style-type: none"> • When registers TRAPRE and TRA are written while the count is stopped, values are written to both the reload register and counter. • When registers TRAPRE and TRA are written during the count, values are written to the reload register and counter (refer to 14.1.1.1 Timer Write Control during Count Operation).
Select functions	<ul style="list-style-type: none"> • Measurement period select The TEDGSEL bit in the TRAIOC register selects the measurement period of the input pulse. • Measured pulse input pin select function P1_7 or P1_5 is selected by the TIOSEL bit in the TRAIOC register. • Digital filter function Bits TIPF0 and TIPF1 in the TRAIOC register enable or disable the digital filter and select the sampling frequency.

NOTE:

1. Input a pulse with a period longer than twice the timer RA prescaler period. Input a pulse with a longer "H" and "L" width than the timer RA prescaler period. If a pulse with a shorter period is input to the TRAIO pin, the input may be ignored.

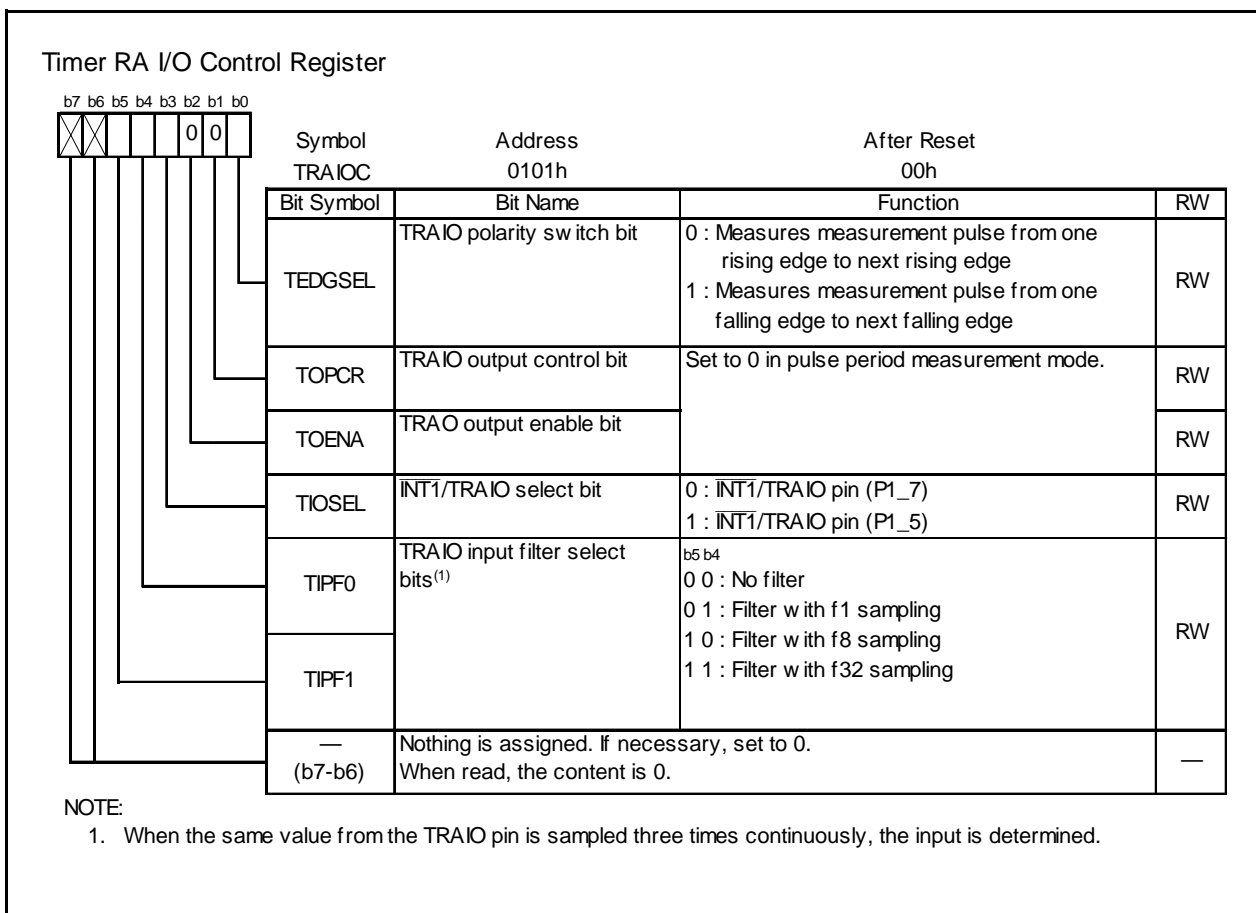

Figure 14.10 TRAI0C Register in Pulse Period Measurement Mode

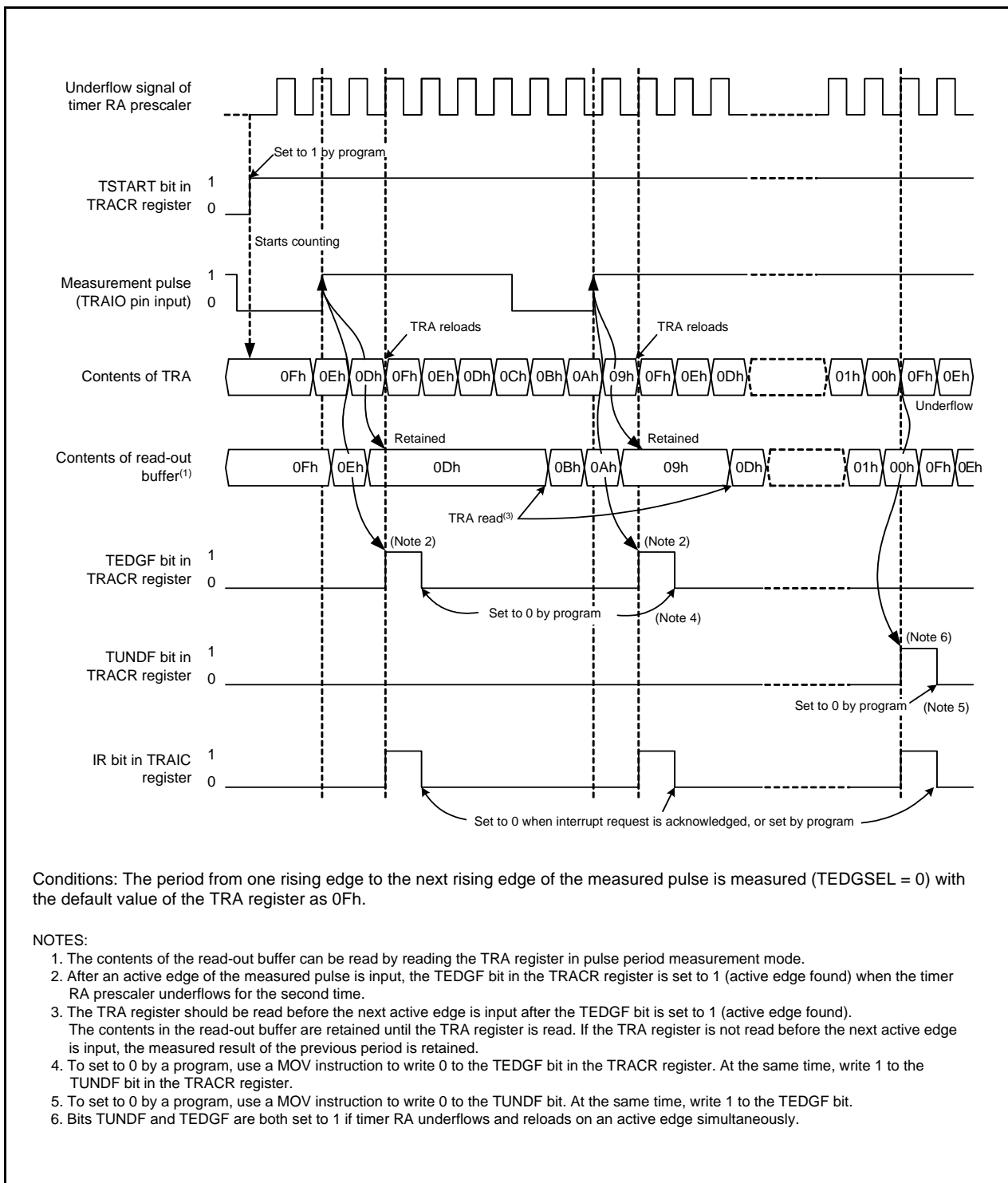

Figure 14.11 Operating Example of Pulse Period Measurement Mode

14.1.6 Notes on Timer RA

- Timer RA stops counting after a reset. Set the values in the timer RA and timer RA prescalers before the count starts.
- Even if the prescaler and timer RA are read out in 16-bit units, these registers are read 1 byte at a time by the MCU. Consequently, the timer value may be updated during the period when these two registers are being read.
- In pulse period measurement mode, bits TEDGF and TUNDF in the TRACR register can be set to 0 by writing 0 to these bits by a program. However, these bits remain unchanged if 1 is written. When using the READ-MODIFY-WRITE instruction for the TRACR register, the TEDGF or TUNDF bit may be set to 0 although these bits are set to 1 while the instruction is being executed. In this case, write 1 to the TEDGF or TUNDF bit which is not supposed to be set to 0 with the MOV instruction.
- When changing to pulse period measurement mode from another mode, the contents of bits TEDGF and TUNDF are undefined. Write 0 to bits TEDGF and TUNDF before the count starts.
- The TEDGF bit may be set to 1 by the first timer RA prescaler underflow generated after the count starts.
- When using the pulse period measurement mode, leave two or more periods of the timer RA prescaler immediately after the count starts, then set the TEDGF bit to 0.
- The TCSTF bit retains 0 (count stops) for 0 to 1 cycle of the count source after setting the TSTART bit to 1 (count starts) while the count is stopped.

During this time, do not access registers associated with timer RA⁽¹⁾ other than the TCSTF bit. Timer RA starts counting at the first valid edge of the count source after The TCSTF bit is set to 1 (during count).

The TCSTF bit remains 1 for 0 to 1 cycle of the count source after setting the TSTART bit to 0 (count stops) while the count is in progress.

During this time, do not access registers associated with timer RA⁽¹⁾ other than the TCSTF bit. Timer RA counting is stopped when the TCSTF bit is set to 0.

NOTE:

1. Registers associated with timer RA: TRACR, TRAIOC, TRAMR, TRAPRE, and TRA.

14.2 Timer RB

Timer RB is an 8-bit timer with an 8-bit prescaler.

The prescaler and timer each consist of a reload register and counter. The reload register and counter are allocated at the same address (refer to **Tables 14.7 to 14.10 the Specifications of Each Mode**).

Timer RB has timer RB primary and timer RB secondary as reload registers.

The count source for timer RB is the operating clock that regulates the timing of timer operations such as counting and reloading.

Figure 14.12 shows a Block Diagram of Timer RB. Figures 14.13 and 14.15 show the registers associated with timer RB.

Timer RB has four operation modes listed as follows:

- Timer mode: The timer counts an internal count source (peripheral function clock or timer RA underflows).
- Programmable waveform generation mode: The timer outputs pulses of a given width successively.
- Programmable one-shot generation mode: The timer outputs a one-shot pulse.
- Programmable wait one-shot generation mode: The timer outputs a delayed one-shot pulse.

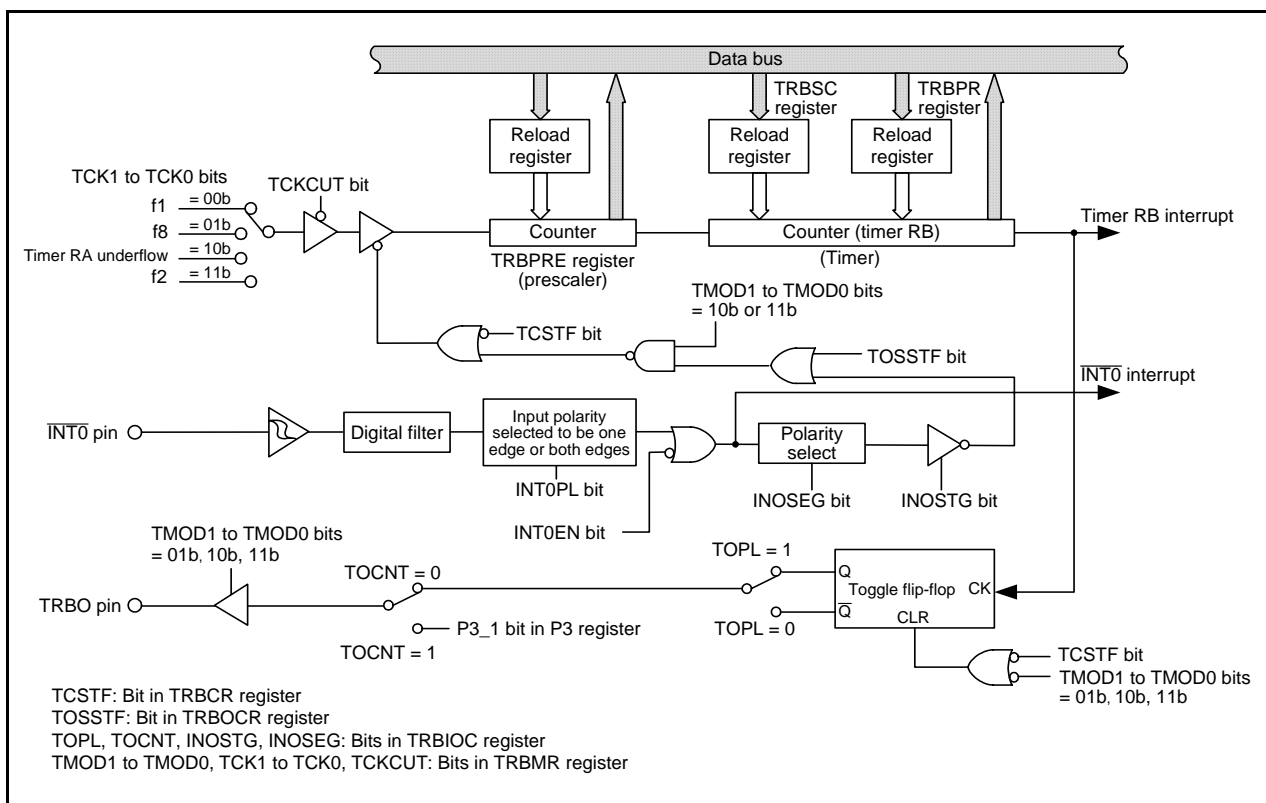

Figure 14.12 Block Diagram of Timer RB

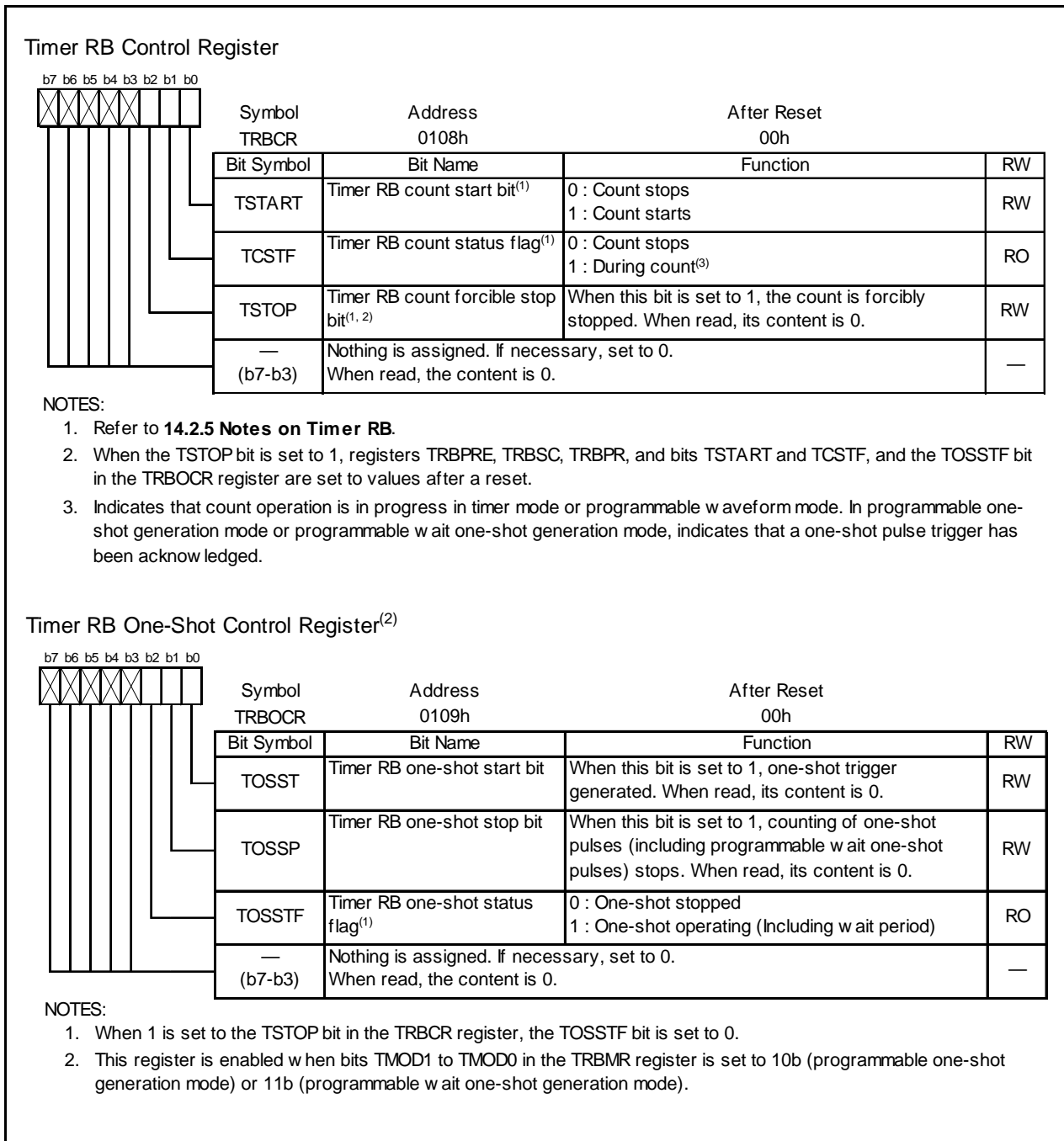

Figure 14.13 Registers TRBCR and TRBOCR

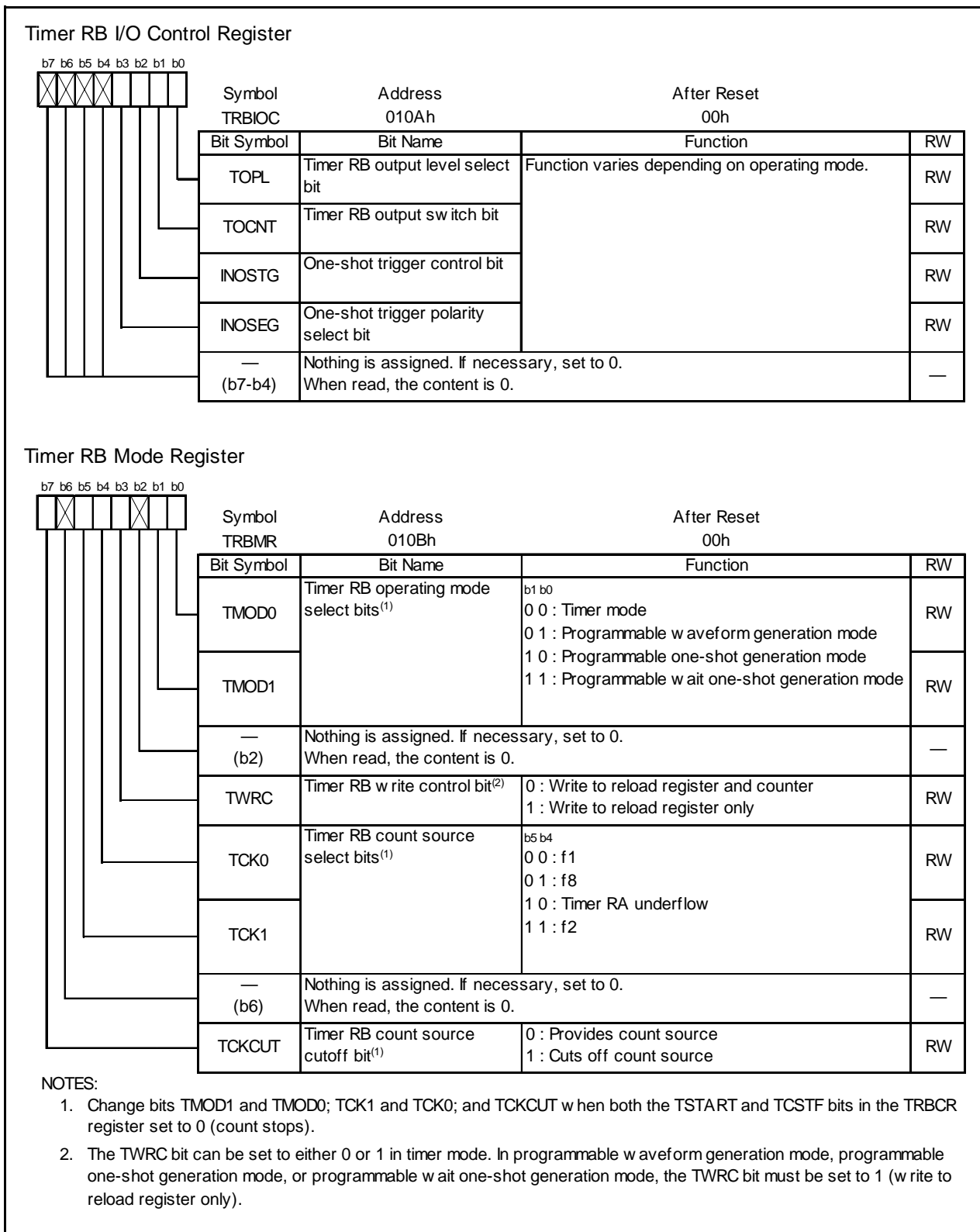

Figure 14.14 Registers TRBIOC and TRBMR

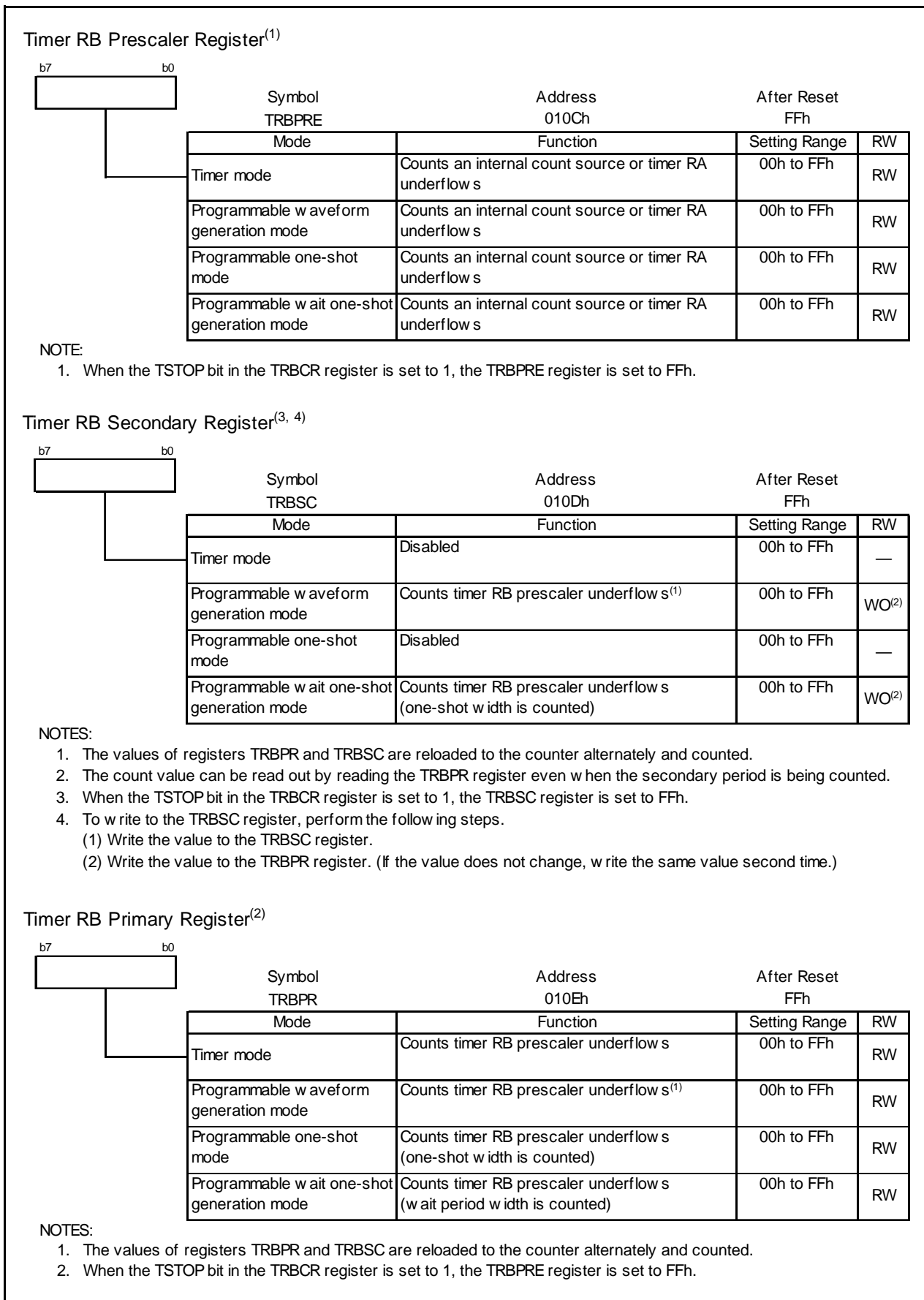

Figure 14.15 Registers TRBPRES, TRBSC, and TRBPR

14.2.1 Timer Mode

In timer mode, a count source which is internally generated or timer RA underflows are counted (refer to **Table 14.7 Timer Mode Specifications**). Registers TRBOCR and TRBSC are not used in timer mode.

Figure 14.16 shows TRBIOC Register in Timer Mode.

Table 14.7 Timer Mode Specifications

Item	Specification
Count sources	f1, f2, f8, timer RA underflow
Count operations	<ul style="list-style-type: none"> Decrement When the timer underflows, it reloads the reload register contents before the count continues (when timer RB underflows, the contents of timer RB primary reload register is reloaded).
Divide ratio	$1/(n+1)(m+1)$ n: setting value in TRBPRES register, m: setting value in TRBPR register
Count start condition	1 (count starts) is written to the TSTART bit in the TRBCR register.
Count stop conditions	<ul style="list-style-type: none"> 0 (count stops) is written to the TSTART bit in the TRBCR register. 1 (count forcibly stops) is written to the TSTOP bit in the TRBCR register.
Interrupt request generation timing	When timer RB underflows [timer RB interrupt].
TRBO pin function	Programmable I/O port
INT0 pin function	Programmable I/O port or $\overline{\text{INT0}}$ interrupt input
Read from timer	The count value can be read out by reading registers TRBPR and TRBPRES.
Write to timer	<ul style="list-style-type: none"> When registers TRBPRES and TRBPR are written while the count is stopped, values are written to both the reload register and counter. When registers TRBPRES and TRBPR are written to while count operation is in progress: If the TWRC bit in the TRBMR register is set to 0, the value is written to both the reload register and the counter. If the TWRC bit is set to 1, the value is written to the reload register only. (Refer to 14.2.1.1 Timer Write Control during Count Operation.)

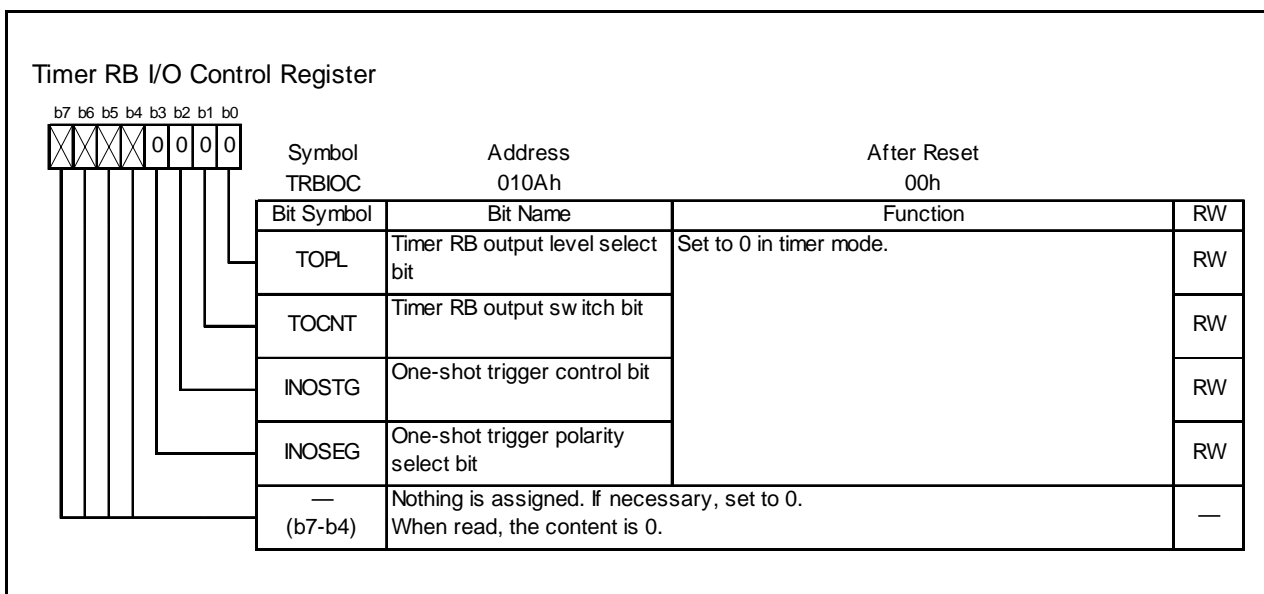

Figure 14.16 TRBIOC Register in Timer Mode

14.2.1.1 Timer Write Control during Count Operation

Timer RB has a prescaler and a timer (which counts the prescaler underflows). The prescaler and timer each consist of a reload register and a counter. In timer mode, the TWRC bit in the TRBMR register can be used to select whether writing to the prescaler or timer during count operation is performed to both the reload register and counter or only to the reload register.

However, values are transferred from the reload register to the counter of the prescaler in synchronization with the count source. In addition, values are transferred from the reload register to the counter of the timer in synchronization with prescaler underflows. Therefore, even if the TWRC bit is set for writing to both the reload register and counter, the counter value is not updated immediately after the WRITE instruction is executed. In addition, if the TWRC bit is set for writing to the reload register only, the synchronization of the writing will be shifted if the prescaler value changes. Figure 14.17 shows an Operating Example of Timer RB when Counter Value is Rewritten during Count Operation.

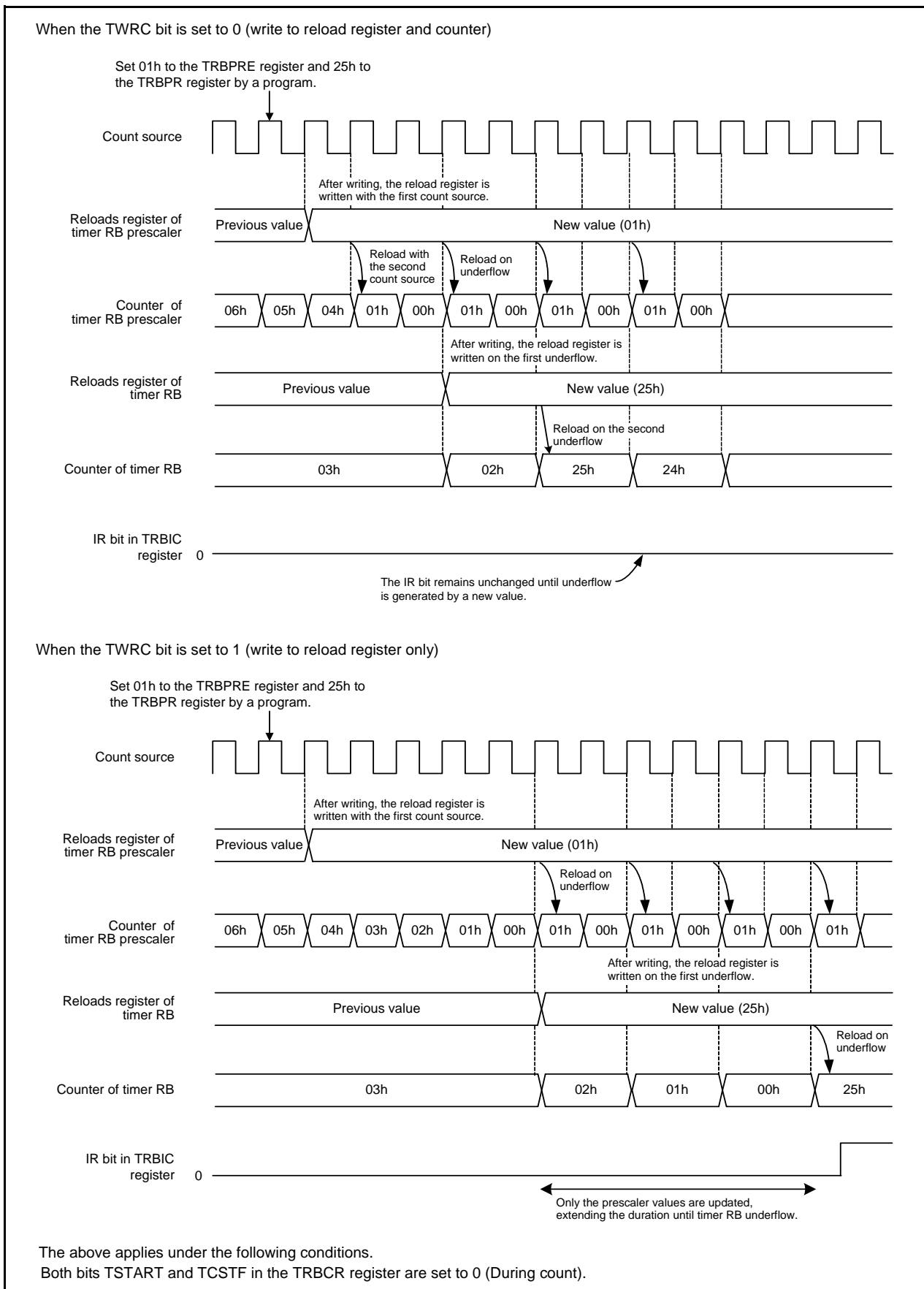

Figure 14.17 Operating Example of Timer RB when Counter Value is Rewritten during Count Operation

14.2.2 Programmable Waveform Generation Mode

In programmable waveform generation mode, the signal output from the TRBO pin is inverted each time the counter underflows, while the values in registers TRBPR and TRBSC are counted alternately (refer to **Table 14.8 Programmable Waveform Generation Mode Specifications**). Counting starts by counting the setting value in the TRBPR register. The TRBOCR register is unused in this mode.

Figure 14.18 shows TRBIOC Register in Programmable Waveform Generation Mode. Figure 14.19 shows an Operating Example of Timer RB in Programmable Waveform Generation Mode.

Table 14.8 Programmable Waveform Generation Mode Specifications

Item	Specification
Count sources	f1, f2, f8, timer RA underflow
Count operations	<ul style="list-style-type: none"> • Decrement • When the timer underflows, it reloads the contents of the primary reload and secondary reload registers alternately before the count continues.
Width and period of output waveform	Primary period: $(n+1)(m+1)/f_i$ Secondary period: $(n+1)(p+1)/f_i$ Period: $(n+1)\{(m+1)+(p+1)\}/f_i$ f_i : Count source frequency n : Value set in TRBPRES register m : Value set in TRBPR register p : Value set in TRBSC register
Count start condition	1 (count starts) is written to the TSTART bit in the TRBCR register.
Count stop conditions	<ul style="list-style-type: none"> • 0 (count stops) is written to the TSTART bit in the TRBCR register. • 1 (count forcibly stops) is written to the TSTOP bit in the TRBCR register.
Interrupt request generation timing	In half a cycle of the count source, after timer RB underflows during the secondary period (at the same time as the TRBO output change) [timer RB interrupt]
TRBO pin function	Programmable output port or pulse output
INT0 pin function	Programmable I/O port or INT0 interrupt input
Read from timer	The count value can be read out by reading registers TRBPR and TRBPRES ⁽¹⁾ .
Write to timer	<ul style="list-style-type: none"> • When registers TRBPRES, TRBSC, and TRBPR are written while the count is stopped, values are written to both the reload register and counter. • When registers TRBPRES, TRBSC, and TRBPR are written to during count operation, values are written to the reload registers only.⁽²⁾
Select functions	<ul style="list-style-type: none"> • Output level select function The TOPL bit in the TRBIOC register selects the output level during primary and secondary periods. • TRBO pin output switch function Timer RB pulse output or P3_1 latch output is selected by the TOCNT bit in the TRBIOC register.⁽³⁾

NOTES:

1. Even when counting the secondary period, the TRBPR register may be read.
2. The set values are reflected in the waveform output beginning with the following primary period after writing to the TRBPR register.
3. The value written to the TOCNT bit is enabled by the following.
 - When count starts.
 - When a timer RB interrupt request is generated.
The contents after the TOCNT bit is changed are reflected from the output of the following primary period.

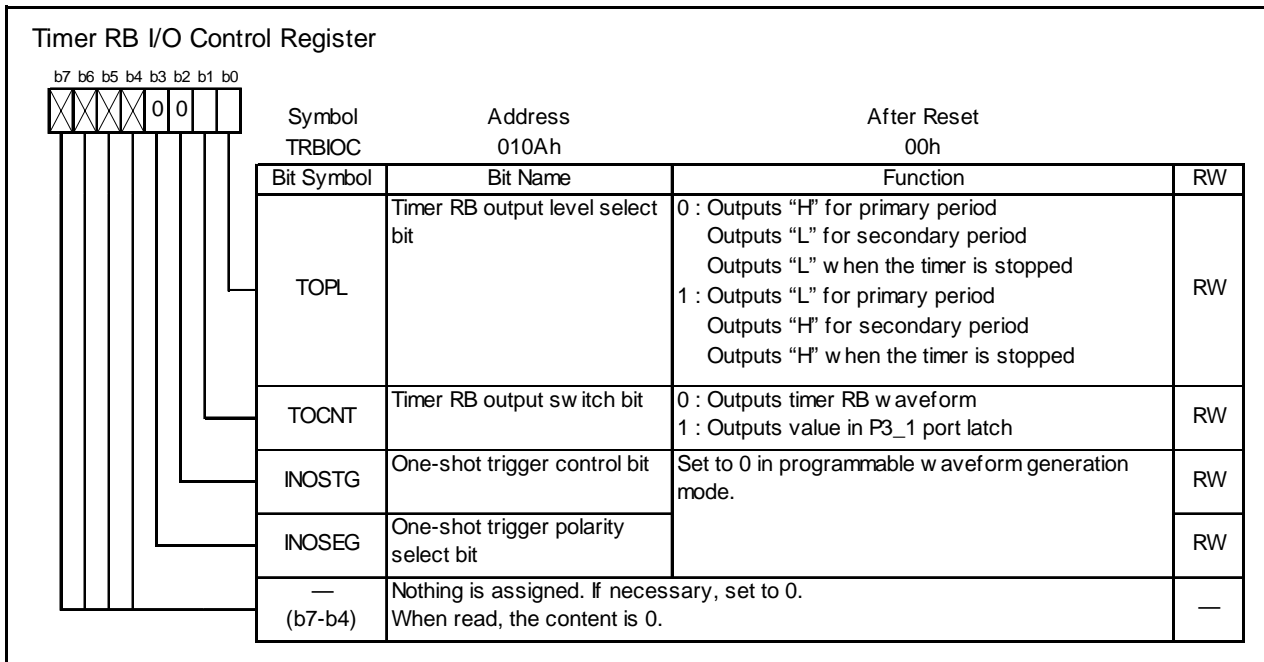

Figure 14.18 TRBIOC Register in Programmable Waveform Generation Mode

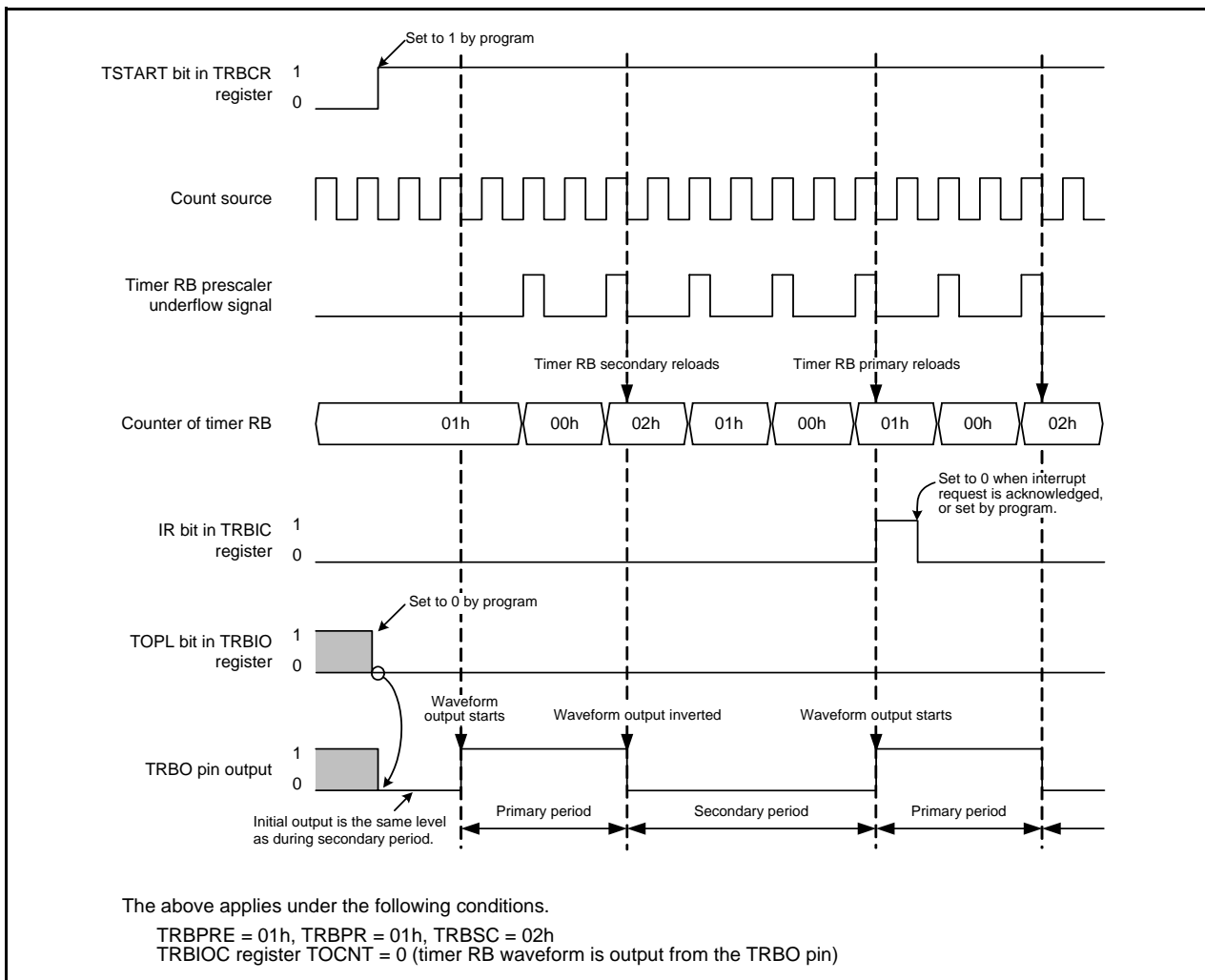

Figure 14.19 Operating Example of Timer RB in Programmable Waveform Generation Mode

14.2.3 Programmable One-shot Generation Mode

In programmable one-shot generation mode, a one-shot pulse is output from the TRBO pin by a program or an external trigger input (input to the INT0 pin) (refer to **Table 14.9 Programmable One-Shot Generation Mode Specifications**). When a trigger is generated, the timer starts operating from the point only once for a given period equal to the set value in the TRBPR register. The TRBSC register is not used in this mode.

Figure 14.20 shows TRBIOC Register in Programmable One-Shot Generation Mode. Figure 14.21 shows an Operating Example of Programmable One-Shot Generation Mode.

Table 14.9 Programmable One-Shot Generation Mode Specifications

Item	Specification
Count sources	f1, f2, f8, timer RA underflow
Count operations	<ul style="list-style-type: none"> Decrement the setting value in the TRBPR register When the timer underflows, it reloads the contents of the reload register before the count completes and the TOSSTF bit is set to 0 (one-shot stops). When the count stops, the timer reloads the contents of the reload register before it stops.
One-shot pulse output time	$(n+1)(m+1)/f_i$ f_i : Count source frequency, n : Setting value in TRBPRES register, m : Setting value in TRBPR register
Count start conditions	<ul style="list-style-type: none"> The TSTART bit in the TRBCR register is set to 1 (count starts) and the next trigger is generated. Set the TOSST bit in the TRBOCR register to 1 (one-shot starts) Input trigger to the INT0 pin
Count stop conditions	<ul style="list-style-type: none"> When reloading completes after timer RB underflows during primary period. When the TOSSP bit in the TRBOCR register is set to 1 (one-shot stops). When the TSTART bit in the TRBCR register is set to 0 (count stops). When the TSTOP bit in the TRBCR register is set to 1 (count forcibly stops).
Interrupt request generation timing	In half a cycle of the count source, after the timer underflows (at the same time as the TRBO output ends) [timer RB interrupt]
TRBP pin function	Pulse output
INT0 pin functions	<ul style="list-style-type: none"> When the INOSTG bit in the TRBIOC register is set to 0 ($\overline{\text{INT0}}$ one-shot trigger disabled): programmable I/O port or INT0 interrupt input When the INOSTG bit in the TRBIOC register is set to 1 ($\overline{\text{INT0}}$ one-shot trigger enabled): external trigger ($\overline{\text{INT0}}$ interrupt input)
Read from timer	The count value can be read out by reading registers TRBPR and TRBPRES.
Write to timer	<ul style="list-style-type: none"> When registers TRBPRES and TRBPR are written while the count is stopped, values are written to both the reload register and counter. When registers TRBPRES and TRBPR are written during the count, values are written to the reload register only (the data is transferred to the counter at the following reload)⁽¹⁾.
Select functions	<ul style="list-style-type: none"> Output level select function The TOPL bit in the TRBIOC register selects the output level of the one-shot pulse waveform. One-shot trigger select function Refer to 14.2.3.1 One-Shot Trigger Selection.

NOTE:

- The set value is reflected at the following one-shot pulse after writing to the TRBPR register.

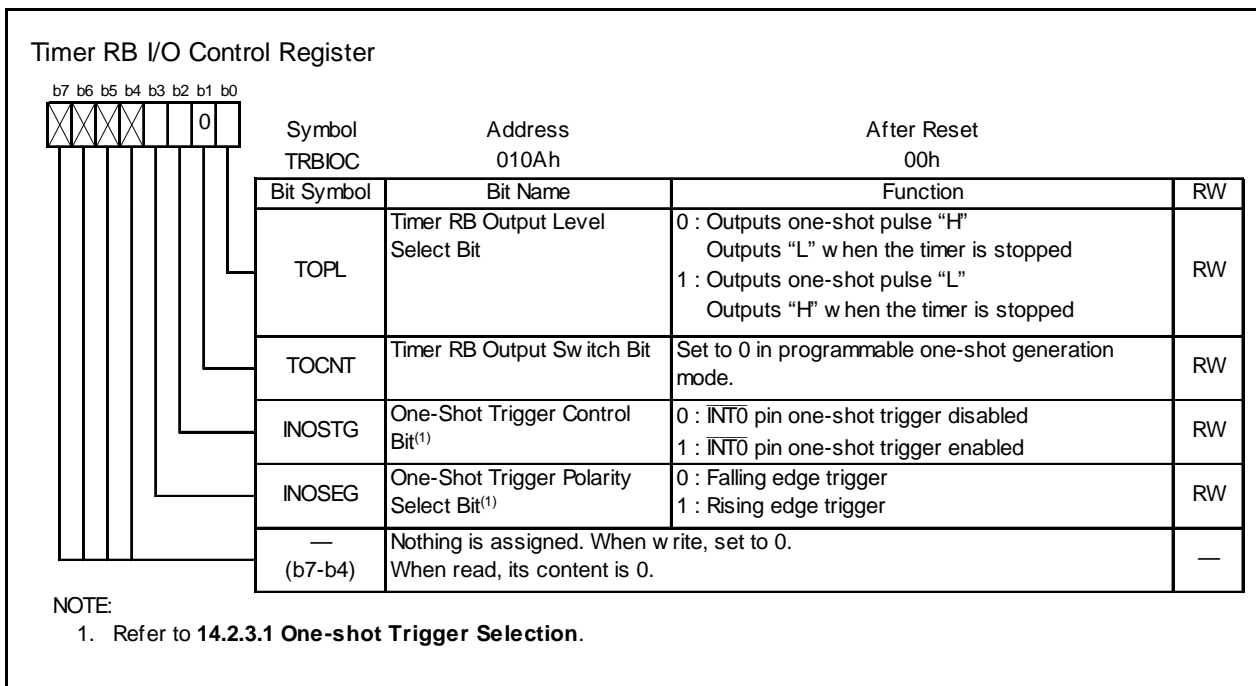

Figure 14.20 TRBIOC Register in Programmable One-Shot Generation Mode

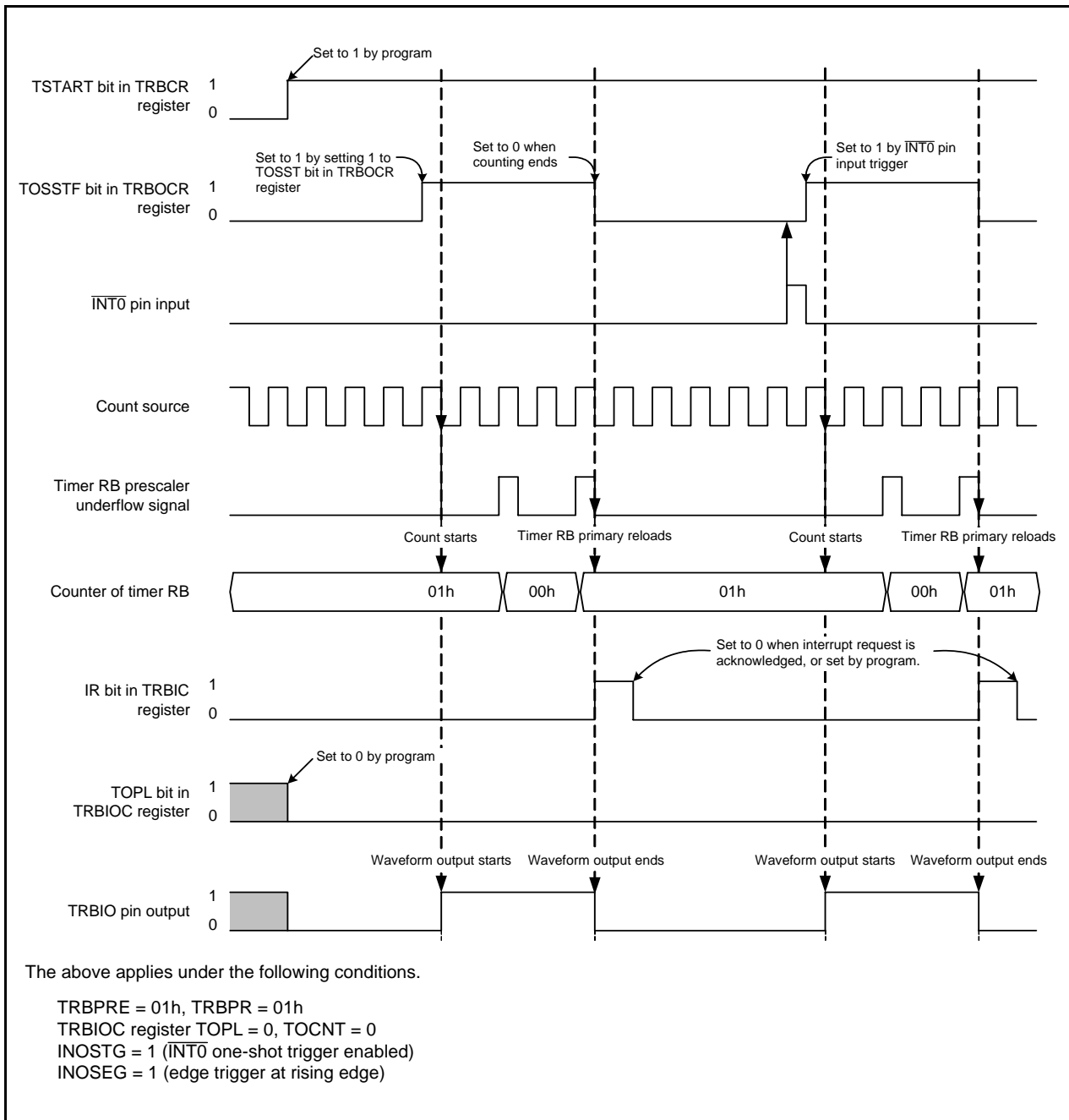

Figure 14.21 Operating Example of Programmable One-Shot Generation Mode

14.2.3.1 One-Shot Trigger Selection

In programmable one-shot generation mode and programmable wait one-shot generation mode, operation starts when a one-shot trigger is generated while the TCSTF bit in the TRBCR register is set to 1 (count starts).

A one-shot trigger can be generated by either of the following causes:

- 1 is written to the TOSST bit in the TRBOCR register by a program.
- Trigger input from the $\overline{\text{INT0}}$ pin.

When a one-shot trigger occurs, the TOSSTF bit in the TRBOCR register is set to 1 (one-shot operation in progress) after one or two cycles of the count source have elapsed. Then, in programmable one-shot generation mode, count operation begins and one-shot waveform output starts. (In programmable wait one-shot generation mode, count operation starts for the wait period.) If a one-shot trigger occurs while the TOSSTF bit is set to 1, no retriggering occurs.

To use trigger input from the $\overline{\text{INT0}}$ pin, input the trigger after making the following settings:

- Set the PD4_5 bit in the PD4 register to 0 (input port).
- Select the $\overline{\text{INT0}}$ digital filter with bits INT0F1 and INT0F0 in the INTF register.
- Select both edges or one edge with the INT0PL bit in INTEN register. If one edge is selected, further select falling or rising edge with the INOSEG bit in TRBIOC register.
- Set the INTOEN bit in the INTEN register to 0 (enabled).
- After completing the above, set the INOSTG bit in the TRBIOC register to 1 ($\overline{\text{INT}}$ pin one-shot trigger enabled).

Note the following points with regard to generating interrupt requests by trigger input from the $\overline{\text{INT0}}$ pin.

- Processing to handle the interrupts is required. Refer to **12. Interrupts**, for details.
- If one edge is selected, use the POL bit in the INT0IC register to select falling or rising edge. (The INOSEG bit in the TRBIOC register does not affect $\overline{\text{INT0}}$ interrupts).
- If a one-shot trigger occurs while the TOSSTF bit is set to 1, timer RB operation is not affected, but the value of the IR bit in the INTOIC register changes.

14.2.4 Programmable Wait One-Shot Generation Mode

In programmable wait one-shot generation mode, a one-shot pulse is output from the TRBO pin by a program or an external trigger input (input to the $\overline{\text{INT0}}$ pin) (refer to **Table 14.10 Programmable Wait One-Shot Generation Mode Specifications**). When a trigger is generated from that point, the timer outputs a pulse only once for a given length of time equal to the setting value in the TRBSC register after waiting for a given length of time equal to the setting value in the TRBPR register.

Figure 14.22 shows TRBIOC Register in Programmable Wait One-Shot Generation Mode. Figure 14.23 shows an Operating Example of Programmable Wait One-Shot Generation Mode.

Table 14.10 Programmable Wait One-Shot Generation Mode Specifications

Item	Specification
Count sources	f1, f2, f8, timer RA underflow
Count operations	<ul style="list-style-type: none"> • Decrement the timer RB primary setting value. • When a count of the timer RB primary underflows, the timer reloads the contents of timer RB secondary before the count continues. • When a count of the timer RB secondary underflows, the timer reloads the contents of timer RB primary before the count completes and the TOSSTF bit is set to 0 (one-shot stops). • When the count stops, the timer reloads the contents of the reload register before it stops.
Wait time	$(n+1)(m+1)/f_i$ f_i : Count source frequency n : Value set in the TRBPRES register, m : Value set in the TRBPR register
One-shot pulse output time	$(n+1)(p+1)/f_i$ f_i : Count source frequency n : Value set in the TRBPRES register, p : Value set in the TRBSC register
Count start conditions	<ul style="list-style-type: none"> • The TSTART bit in the TRBCR register is set to 1 (count starts) and the next trigger is generated. • Set the TOSST bit in the TRBOCR register to 1 (one-shot starts). • Input trigger to the INT0 pin
Count stop conditions	<ul style="list-style-type: none"> • When reloading completes after timer RB underflows during secondary period. • When the TOSSP bit in the TRBOCR register is set to 0 (one-shot stops). • When the TSTART bit in the TRBCR register is set to 0 (count starts). • When the TSTOP bit in the TRBCR register is set to 1 (count forcibly stops).
Interrupt request generation timing	In half a cycle of the count source after timer RB underflows during secondary period (complete at the same time as waveform output from the TRBO pin) [timer RB interrupt].
TRBO pin function	Pulse output
INT0 pin functions	<ul style="list-style-type: none"> • When the INOSTG bit in the TRBIOC register is set to 0 ($\overline{\text{INT0}}$ one-shot trigger disabled): programmable I/O port or INT0 interrupt input • When the INOSTG bit in the TRBIOC register is set to 1 ($\overline{\text{INT0}}$ one-shot trigger enabled): external trigger ($\overline{\text{INT0}}$ interrupt input)
Read from timer	The count value can be read out by reading registers TRBPR and TRBPRES.
Write to timer	<ul style="list-style-type: none"> • When registers TRBPRES, TRBSC, and TRBPR are written while the count stops, values are written to both the reload register and counter. • When registers TRBPRES, TRBSC, and TRBPR are written to during count operation, values are written to the reload registers only.⁽¹⁾
Select functions	<ul style="list-style-type: none"> • Output level select function The TOPL bit in the TRBIOC register selects the output level of the one-shot pulse waveform. • One-shot trigger select function Refer to 14.2.3.1 One-Shot Trigger Selection.

NOTE:

1. The set value is reflected at the following one-shot pulse after writing to registers TRBSC and TRBPR.

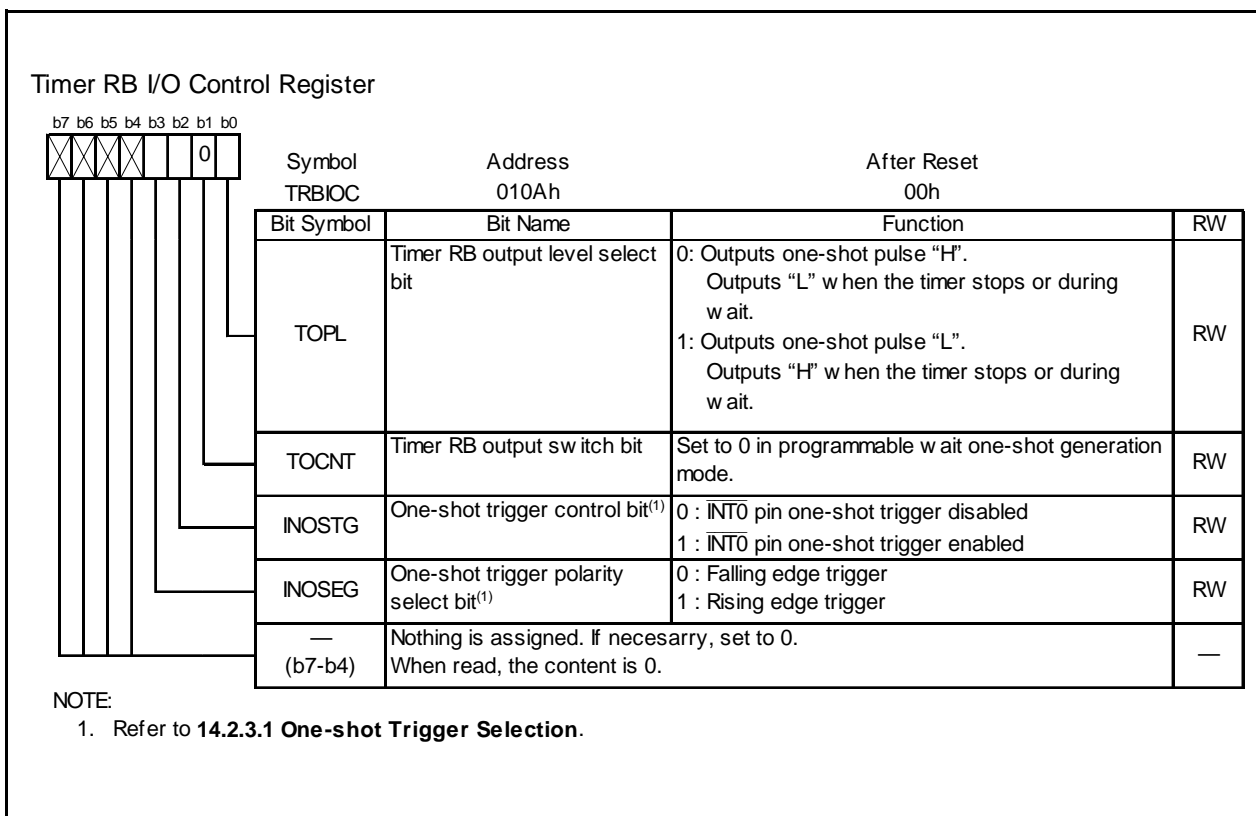

Figure 14.22 TRBIOC Register in Programmable Wait One-Shot Generation Mode

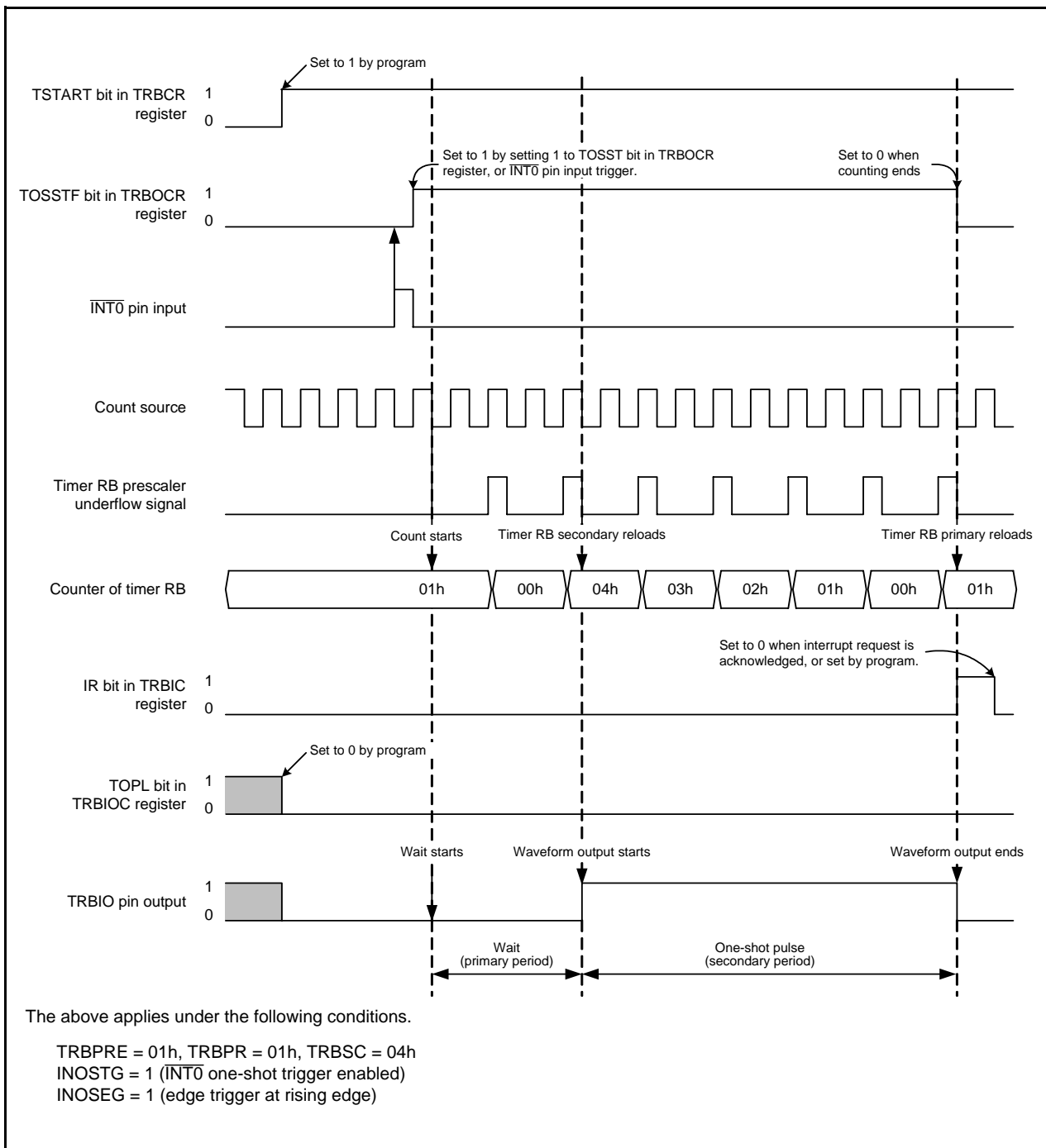

Figure 14.23 Operating Example of Programmable Wait One-Shot Generation Mode

14.2.5 Notes on Timer RB

- Timer RB stops counting after a reset. Set the values in the timer RB and timer RB prescalers before the count starts.
- Even if the prescaler and timer RB is read out in 16-bit units, these registers are read 1 byte at a time by the MCU. Consequently, the timer value may be updated during the period when these two registers are being read.
- In programmable one-shot generation mode and programmable wait one-shot generation mode, when setting the TSTART bit in the TRBCR register to 0 (count stops) or setting the TOSSP bit in the TRBOCR register to 1 (one-shot stops), the timer reloads the value of reload register and stops. Therefore, in programmable one-shot generation mode and programmable wait one-shot generation mode, read the timer count value before the timer stops.
- The TCSTF bit remains 0 (count stops) for 1 to 2 cycles of the count source after setting the TSTART bit to 1 (count starts) while the count is stopped.
During this time, do not access registers associated with timer RB⁽¹⁾ other than the TCSTF bit.
The TCSTF bit remains 1 for 1 to 2 cycles of the count source after setting the TSTART bit to 0 (count stops) while the count is in progress.
During this time, do not access registers associated with timer RB⁽¹⁾ other than the TCSTF bit.
Timer RB counting is stopped when the TCSTF bit is set to 0.

NOTE:

1. Registers associated with timer RB: TRBCR, TRBOCR, TRBMR, TRBPRES, TRBSC, and TRRBPR.
- If the TSTOP bit in the TRBCR register is set to 1 during timer operation, timer RB stops immediately.
 - If 1 is written to the TOSST or TOSSP bit in the TRBOCR register, the value of the TOSSTF bit changes after one or two cycles of the count source have elapsed. If the TOSSP bit is written to 1 during the period between when the TOSST bit is written to 1 and when the TOSSTF bit is set to 1, the TOSSTF bit may be set to either 0 or 1 depending on the content state. Likewise, if the TOSST bit is written to 1 during the period between when the TOSSP bit is written to 1 and when the TOSSTF bit is set to 0, the TOSSTF bit may be set to either 0 or 1.

14.3 Timer RD

Timer RD has 2 16-bit timers (channels 0 and 1). Each channel has 4 I/O pins.

The operation clock of timer RD is f1 or fOCO40M. Table 14.11 lists the Timer RD Operation Clocks.

Table 14.11 Timer RD Operation Clocks

Condition	Operation Clock of Timer RD
The count source is f1, f2, f4, f8, f32, or TRDCLK input (bits TCK2 to TCK0 in registers TRDCR0 and TRDCR1 are set to a value from 000b to 101b).	f1
The count source is fOCO40M (bits TCK2 to TCK0 in registers TRDCR0 and TRDCR1 are set to 110b).	fOCO40M

Figure 14.24 shows a Block Diagram of Timer RD. Timer RD has 5 modes:

- Timer mode
 - Input capture function Transfer the counter value to a register with an external signal as the trigger
 - Output compare function Detect register value matches with a counter (Pin output can be changed at detection)

The following 4 modes use the output compare function.

- PWM mode Output pulse of any width continuously
- Reset synchronous PWM mode Output three-phase waveforms (6) without sawtooth wave modulation and dead time
- Complementary PWM mode Output three-phase waveforms (6) with triangular wave modulation and dead time
- PWM3 mode Output PWM waveforms (2) with a fixed period

In the input capture function, output compare function, and PWM mode, channels 0 and 1 have the equivalent functions, and functions or modes can be selected individually for each pin. Also, a combination of these functions and modes can be used in 1 channel.

In reset synchronous PWM mode, complementary PWM mode, and PWM3 mode, a waveform is output with a combination of counters and registers in channels 0 and 1.

Tables 14.12 to 14.20 list the Pin Functions of timer RD.

Table 14.12 Pin Functions TRDIOA0/TRDCLK(P2_0)

Register	TRDOER1	TRDFCR			TRDIOA0		Function
Bit	EA0	PWM3	STCLK	CMD1, CMD0	IOA3	IOA2_IOA0	
Setting value	0	0	0	00b	X	XXXb	PWM3 mode waveform output
	0	1	0	00b	1	001b, 01Xb	Timer mode waveform output (output compare function)
	X	1	0	00b	X	1XXb	Timer mode trigger input (input capture function) ⁽¹⁾
		1	1	XXb	X	000b	External clock input (TRDCLK) ⁽¹⁾
	Other than above						

X: can be 0 or 1, no change in outcome

NOTE:

- Set the PD2_0 bit in the PD2 register to 0 (input mode) at timer mode trigger input (input capture function) and external clock input (TRDCLK).

Table 14.13 Pin Functions TRDIOB0(P2_1)

Register	TRDOER1	TRDFCR		TRDPMR	TRDIOA0	Function
Bit	EB0	PWM3	CMD1, CMD0	PWMB0	IOB2_IOB0	
Setting value	0	X	1Xb	X	XXXb	Complementary PWM mode waveform output
	0	X	01b	X	XXXb	Reset synchronous PWM mode waveform output
	0	0	00b	X	XXXb	PWM3 mode waveform output
	0	1	00b	1	XXXb	PWM mode waveform output
	0	1	00b	0	001b, 01Xb	Timer mode waveform output (output compare function)
	X	1	00b	0	1XXb	Timer mode trigger input (input capture function) ⁽¹⁾
	Other than above					

X: can be 0 or 1, no change in outcome

NOTE:

- Set the PD2_1 bit in the PD2 register to 0 (input mode) at timer mode trigger input (input capture function).

Table 14.14 Pin Functions TRDIOC0(P2_2)

Register	TRDOER1	TRDFCR		TRDPMR	TRDIOA0	Function
Bit	EC0	PWM3	CMD1, CMD0	PWMC0	IOC2_IOC0	
Setting value	0	X	1Xb	X	XXXb	Complementary PWM mode waveform output
	0	X	01b	X	XXXb	Reset synchronous PWM mode waveform output
	0	1	00b	1	XXXb	PWM mode waveform output
	0	1	00b	0	001b, 01Xb	Timer mode waveform output (output compare function)
	X	1	00b	0	1XXb	Timer mode trigger input (input capture function) ⁽¹⁾
	Other than above					

X: can be 0 or 1, no change in outcome

NOTE:

- Set the PD2_2 bit in the PD2 register to 0 (input mode) at timer mode trigger input (input capture function).

Table 14.15 Pin Functions TRDIOD0(P2_3)

Register	TRDOER1	TRDFCR		TRDPMR	TRDIORC0	Function
Bit	ED0	PWM3	CMD1, CMD0	PWMD0	IOD2_IOD0	
Setting value	0	X	1Xb	X	XXXb	Complementary PWM mode waveform output
	0	X	01b	X	XXXb	Reset synchronous PWM mode waveform output
	0	1	00b	1	XXXb	PWM mode waveform output
	0	1	00b	0	001b, 01Xb	Timer mode waveform output (output compare function)
	X	1	00b	0	1XXb	Timer mode trigger input (input capture function) ⁽¹⁾
Other than above						I/O port

X: can be 0 or 1, no change in outcome

NOTE:

1. Set the PD2_3 bit in the PD2 register to 0 (input mode) at timer mode trigger input (input capture function).

Table 14.16 Pin Functions TRDIOA1(P2_4)

Register	TRDOER1	TRDFCR		TRDIOA1	Function
Bit	EA1	PWM3	CMD1, CMD0	IOA2_IOA0	
Setting value	0	X	1Xb	XXXb	Complementary PWM mode waveform output
	0	X	01b	XXXb	Reset synchronous PWM mode waveform output
	0	1	00b	001b, 01Xb	Timer mode waveform output (output compare function)
	X	1	00b	1XXb	Timer mode trigger input (input capture function) ⁽¹⁾
Other than above					I/O port

X: can be 0 or 1, no change in outcome

NOTE:

1. Set the PD2_4 bit in the PD2 register to 0 (input mode) at timer mode trigger input (input capture function).

Table 14.17 Pin Functions TRDIOB1(P2_5)

Register	TRDOER1	TRDFCR		TRDPMR	TRDIOA1	Function
Bit	EB1	PWM3	CMD1, CMD0	PWMB1	IOB2_IOB0	
Setting value	0	X	1Xb	X	XXXb	Complementary PWM mode waveform output
	0	X	01b	X	XXXb	Reset synchronous PWM mode waveform output
	0	1	00b	1	XXXb	PWM mode waveform output
	0	1	00b	0	001b, 01Xb	Timer mode waveform output (output compare function)
	X	1	00b	0	1XXb	Timer mode trigger input (input capture function) ⁽¹⁾
Other than above						I/O port

X: can be 0 or 1, no change in outcome

NOTE:

1. Set the PD2_5 bit in the PD2 register to 0 (input mode) at timer mode trigger input (input capture function).

Table 14.18 Pin Functions TRDIOC1(P2_6)

Register	TRDOER1	TRDFCR		TRDPMR	TRDIORC1	Function
Bit	EC1	PWM3	CMD1, CMD0	PWMC1	IOC2_IOC0	
Setting value	0	X	1Xb	X	XXXb	Complementary PWM mode waveform output
	0	X	01b	X	XXXb	Reset synchronous PWM mode waveform output
	0	1	00b	1	XXXb	PWM mode waveform output
	0	1	00b	0	001b, 01Xb	Timer mode waveform output (output compare function)
	X	1	00b	0	1XXb	Timer mode trigger input (input capture function) ⁽¹⁾
Other than above						I/O port

X: can be 0 or 1, no change in outcome

NOTE:

1. Set the PD2_6 bit in the PD2 register to 0 (input mode) at timer mode trigger input (input capture function).

Table 14.19 Pin Functions TRDIOD1(P2_7)

Register	TRDOER1	TRDFCR		TRDPMR	TRDIORC1	Function
Bit	ED1	PWM3	CMD1, CMD0	PWMD1	IOD2_IOD0	
Setting value	0	X	1Xb	X	XXXb	Complementary PWM mode waveform output
	0	X	01b	X	XXXb	Reset synchronous PWM mode waveform output
	0	1	00b	1	XXXb	PWM mode waveform output
	0	1	00b	0	001b, 01Xb	Timer mode waveform output (output compare function)
	X	1	00b	0	1XXb	Timer mode trigger input (input capture function) ⁽¹⁾
Other than above						I/O port

X: can be 0 or 1, no change in outcome

NOTE:

1. Set the PD2_7 bit in the PD2 register to 0 (input mode) at timer mode trigger input (input capture function).

Table 14.20 Pin Functions $\overline{\text{INT0}}$ (P4_5)

Register	TRDOER2	INTEN		PD4	Function
Bit	PTO	INT0PL	INT0EN	PD4_5	
Setting value	1	0	1	0	Pulse output forced cutoff signal input
Other than above					I/O port or $\overline{\text{INT0}}$ interrupt input

X: can be 0 or 1, no change in outcome

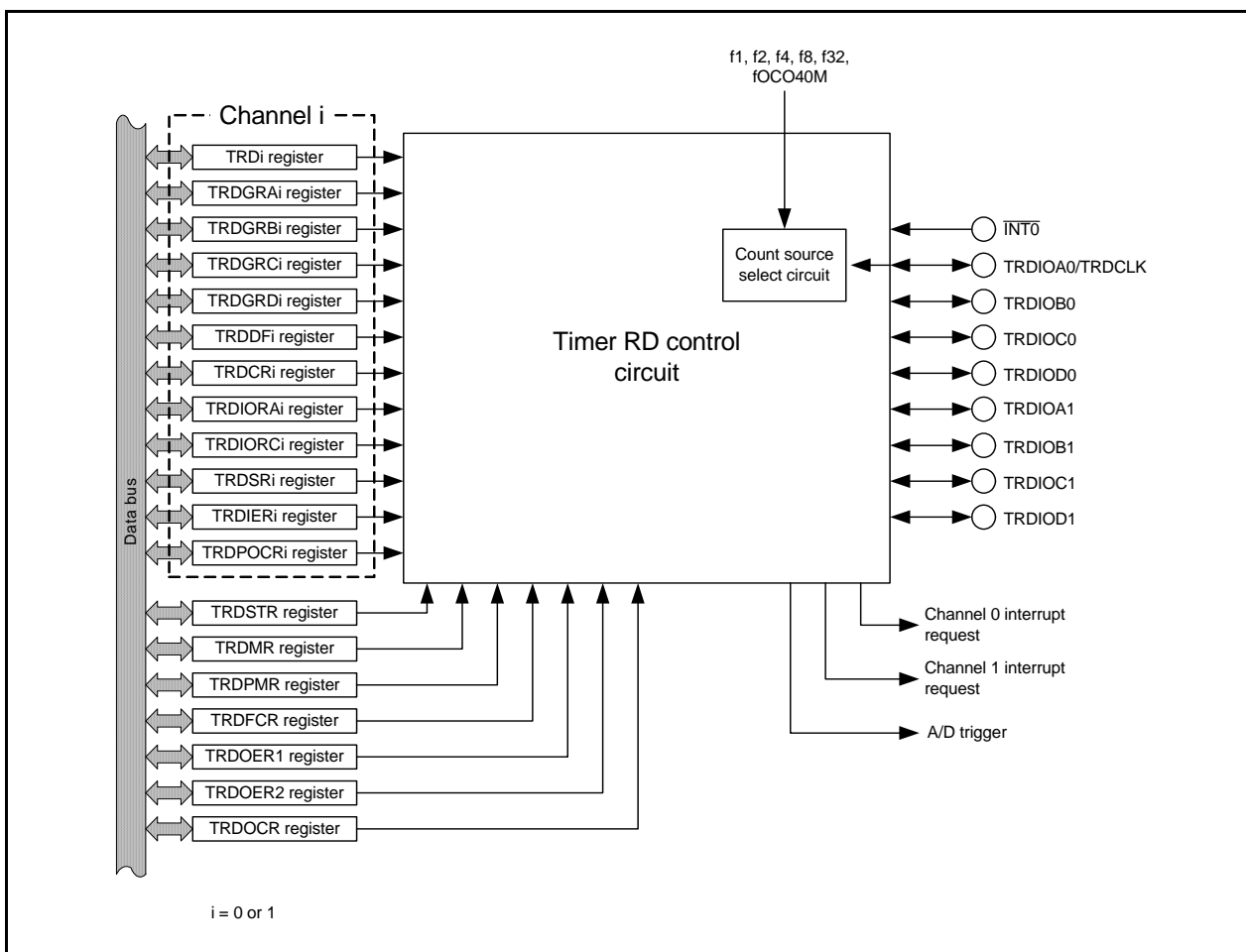

Figure 14.24 Block Diagram of Timer RD

14.3.1 Count Sources

The count source selection method is the same in all modes. However, in PWM3 mode, the external clock cannot be selected.

Table 14.21 Count Source Selection

Count Source	Selection
f1, f2, f4, f8, f32	The count source is selected by bits TCK2 to TCK0 in the TRDCRi register.
fOCO40M ⁽¹⁾	The FRA00 bit in the FRA0 register is set to 1 (high-speed on-chip oscillator frequency). Bits TCK2 to TCK0 in the TRDCRi register is set to 110b (fOCO40M).
External signal input to TRDCLK pin	The STCLK bit in the TRDFCR register is set to 1 (external clock input enabled). Bits TCK2 to TCK0 in the TRDCRi register are set to 101b (count source: external clock). The valid edge is selected by bits CKEG1 to CKEG0 in the TRDCRi register. The PD2_0 bit in the PD2 register is set to 0 (input mode).

i = 0 or 1

NOTE:

1. The count source fOCO40M can be used with VCC = 3.0 to 5.5 V.

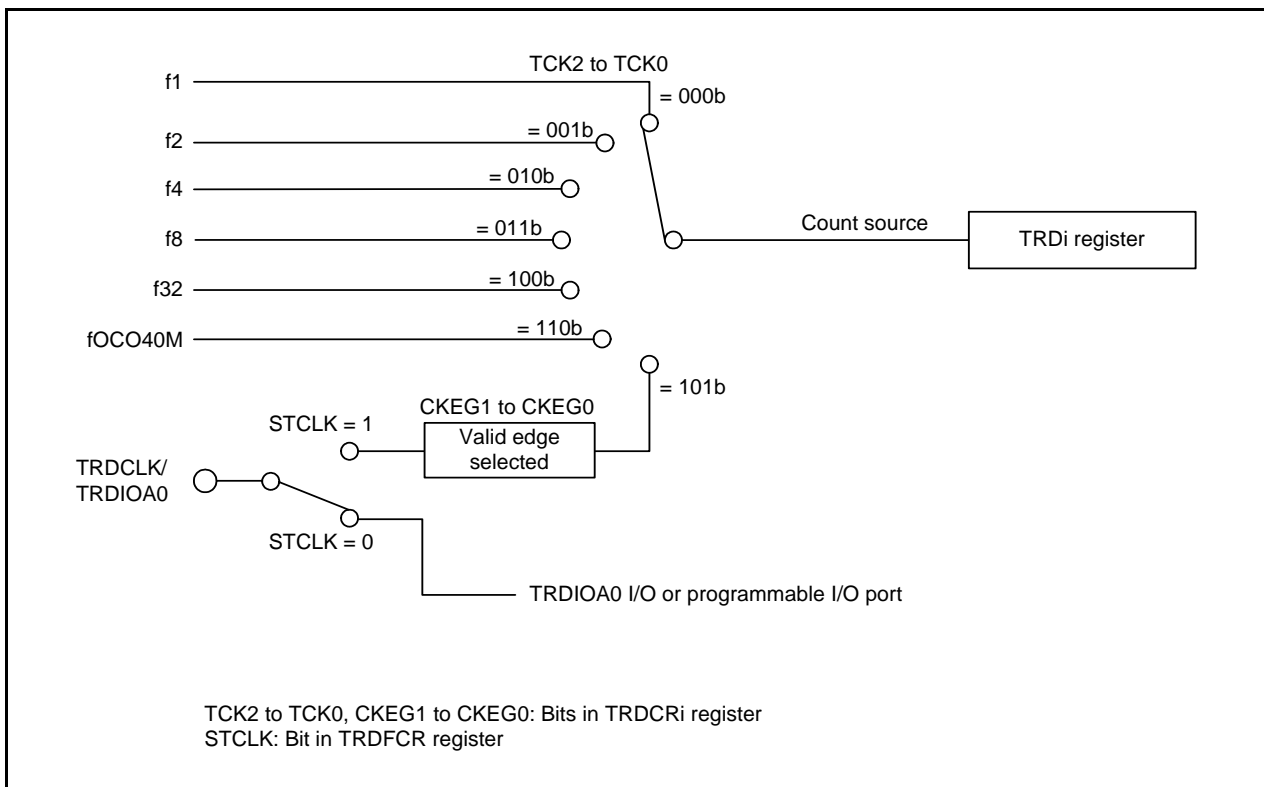

Figure 14.25 Block Diagram of Count Source

Set the pulse width of the external clock which inputs to the TRDCLK pin to 3 cycles or above of the operation clock of timer RD (refer to **Table 14.11 Timer RD Operation Clocks**).

When selecting fOCO40M for the count source, set the FRA00 bit in the FRA0 register to 1 (high-speed on-chip oscillator on) before setting bits TCK2 to TCK0 in the TRDCRi register (i = 0 or 1) to 110b (fOCO40M).

14.3.2 Buffer Operation

The TRDGRC_i ($i = 0$ or 1) register can be used as the buffer register of the TRDGRA_i register, and the TRDGRD_i register can be used as the buffer register of the TRDGRB_i register by means of bits BFC_i and BFD_i in the TRDMR register.

- TRDGRA_i buffer register: TRDGRC_i register
- TRDGRB_i buffer register: TRDGRD_i register

Buffer operation depends on the mode. Table 14.22 lists the Buffer Operation in Each Mode.

Table 14.22 Buffer Operation in Each Mode

Function and Mode	Transfer Timing	Transfer Register
Input capture function	Input capture signal input	Transfer content in TRDGRA _i (TRDGRB _i) register to buffer register
Output compare function	Compare match with TRD _i register and TRDGRA _i (TRDGRB _i) register	Transfer content in buffer register to TRDGRA _i (TRDGRB _i) register
PWM mode		
Reset synchronous PWM mode	Compare match with TRD ₀ register and TRDGRA ₀ register	Transfer content in buffer register to TRDGRA _i (TRDGRB _i) register
Complementary PWM mode	<ul style="list-style-type: none"> • Compare match with TRD₀ register and TRDGRA₀ register • TRD₁ register underflow 	Transfer content in buffer register to registers TRDGRB ₀ , TRDGRA ₁ , and TRDGRB ₁
PWM3 mode	Compare match with TRD ₀ register and TRDGRA ₀ register	Transfer content in buffer register to registers TRDGRA ₀ , TRDGRB ₀ , TRDGRA ₁ , and TRDGRB ₁

$i = 0$ or 1

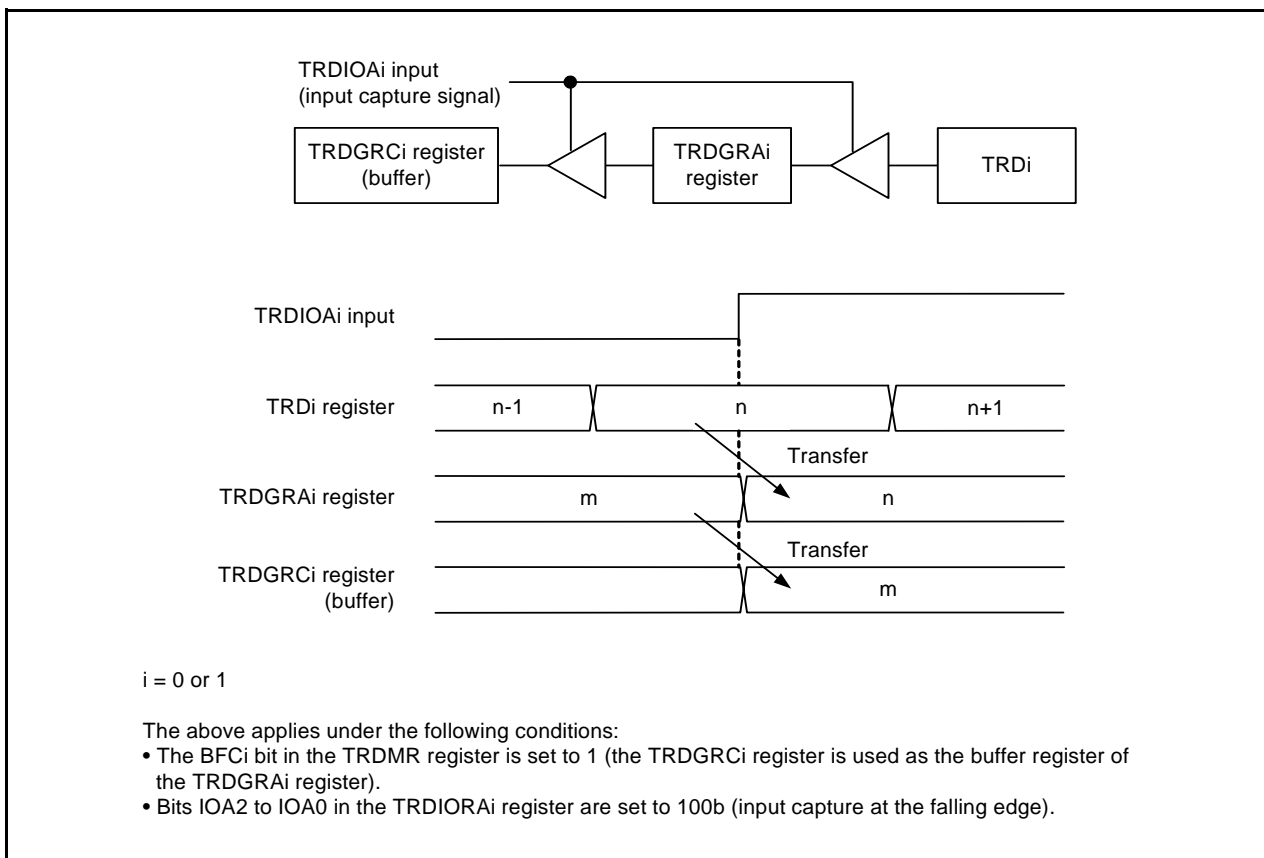

Figure 14.26 Buffer Operation in Input Capture Function

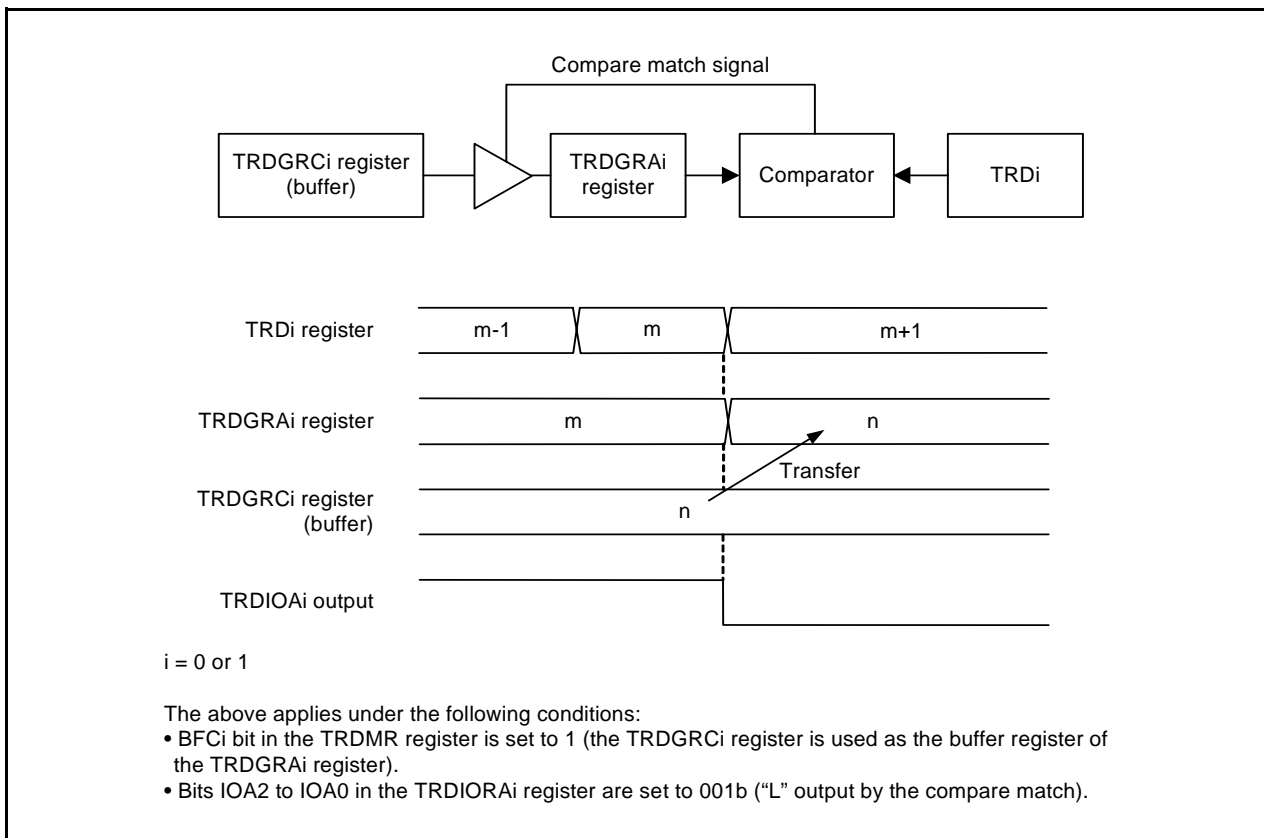

Figure 14.27 Buffer Operation in Output Compare Function

Perform the following for the timer mode (input capture and output compare functions).

When using the TRDGRCi ($i = 0 \text{ or } 1$) register as the buffer register of the TRDGRAi register

- Set the IOC3 bit in the TRDIORCi register to 1 (general register or buffer register).
- Set the IOC2 bit in the TRDIORCi register to the same value as the IOA2 bit in the TRDIORAi register.

When using the TRDGRDi register as the buffer register of the TRDGRBi register

- Set the IOD3 bit in the TRDIORDi register to 1 (general register or buffer register).
- Set the IOD2 bit in the TRDIORCi register to the same value as the IOB2 bit in the TRDIORAi register.

Bits IMFC and IMFD in the TRDSRi register are set to 1 at the input edge of the TRDIOCi pin when also using registers TRDGRCi and TRDGRDi as the buffer register in the input capture function.

When also using registers TRDGRCi and TRDGRDi as buffer registers for the output compare function, reset synchronous PWM mode, complementary PWM mode, and PWM3 mode, bits IMFC and IMFD in the TRDSRi register are set to 1 by a compare match with the TRDi register.

14.3.3 Synchronous Operation

The TRD1 register is synchronized with the TRD0 register.

- Synchronous preset

When the SYNC bit in the TRDMR register is set to 1 (synchronous operation), the data is written to both the TRD0 and TRD1 registers after writing to the TRDi register.

- Synchronous clear

When the SYNC bit in the TRDMR register is set to 1 and bits CCLR2 to CCLR0 in the TRDCRi register are set to 011b (synchronous clear), the TRD0 register is set to 0000h at the same time as the TRD1 register is set to 0000h.

Also, when the SYNC bit in the TRDMR register is set to 1 and bits CCLR2 to CCLR0 in the TRDCRi register are set to 011b (synchronous clear), the TRD1 register is set to 0000h at the same time as the TRD0 register is set to 0000h.

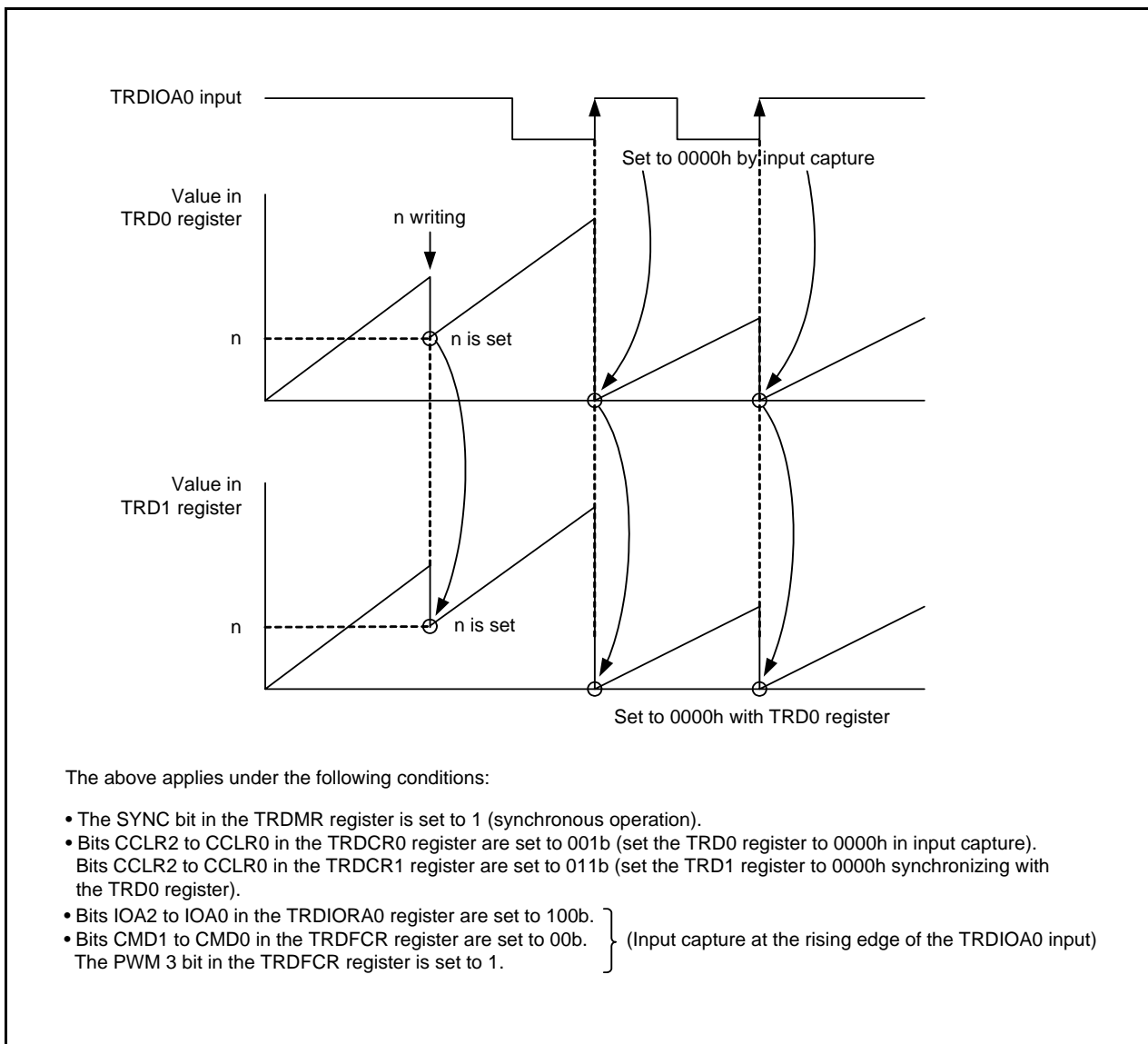

Figure 14.28 Synchronous Operation

14.3.4 Pulse Output Forced Cutoff

In the output compare function, PWM mode, reset synchronous PWM mode, complementary PWM mode, and PWM3 mode, the TRDIO_{ji} (i = 0 or 1, j = either A, B, C, or D) output pin can be forcibly set to a programmable I/O port by the $\overline{\text{INT0}}$ pin input, and pulse output can be cut off.

The pins used for output in these functions or modes can function as the output pin of timer RD when the applicable bit in the TRDOER1 register is set to 0 (enable timer RD output). When the PTO bit in the TRDOER2 register is set to 1 ($\overline{\text{INT0}}$ of pulse output forced cutoff signal input enabled), all bits in the TRDOER1 register are set to 1 (disable timer RD output, the TRDIO_{ji} output pin is used as the programmable I/O port) after “L” is applied to the $\overline{\text{INT0}}$ pin. The TRDIO_{ji} output pin is set to the programmable I/O port after “L” is applied to the $\overline{\text{INT0}}$ pin and waiting for 1 to 2 cycles of the timer RD operation clock (refer to **Table 14.11 Timer RD Operation Clocks**).

Set as below when using this function:

- Set the pin status (high impedance, “L” or “H” output) to pulse output forced cutoff by registers P2 and PD2.
- Set the INT0EN bit in the INTEN register to 1 (enable $\overline{\text{INT0}}$ input) and the INT0PL bit to 0 (one edge).
- Set the PD4_5 bit in the PD4 register to 0 (input mode).
- Set the $\overline{\text{INT0}}$ digital filter by bits INT0F1 to INT0F0 in the INTF register.
- Set the PTO bit in the TRDOER2 register to 1 (enable pulse output forced cutoff signal input $\overline{\text{INT0}}$).

According to the selection of the POL bit in the INT0IC register and change of the $\overline{\text{INT0}}$ pin input, the IR bit in the INT0IC register is set to 1 (interrupt request). Refer to **12. Interrupts** for details of interrupts.

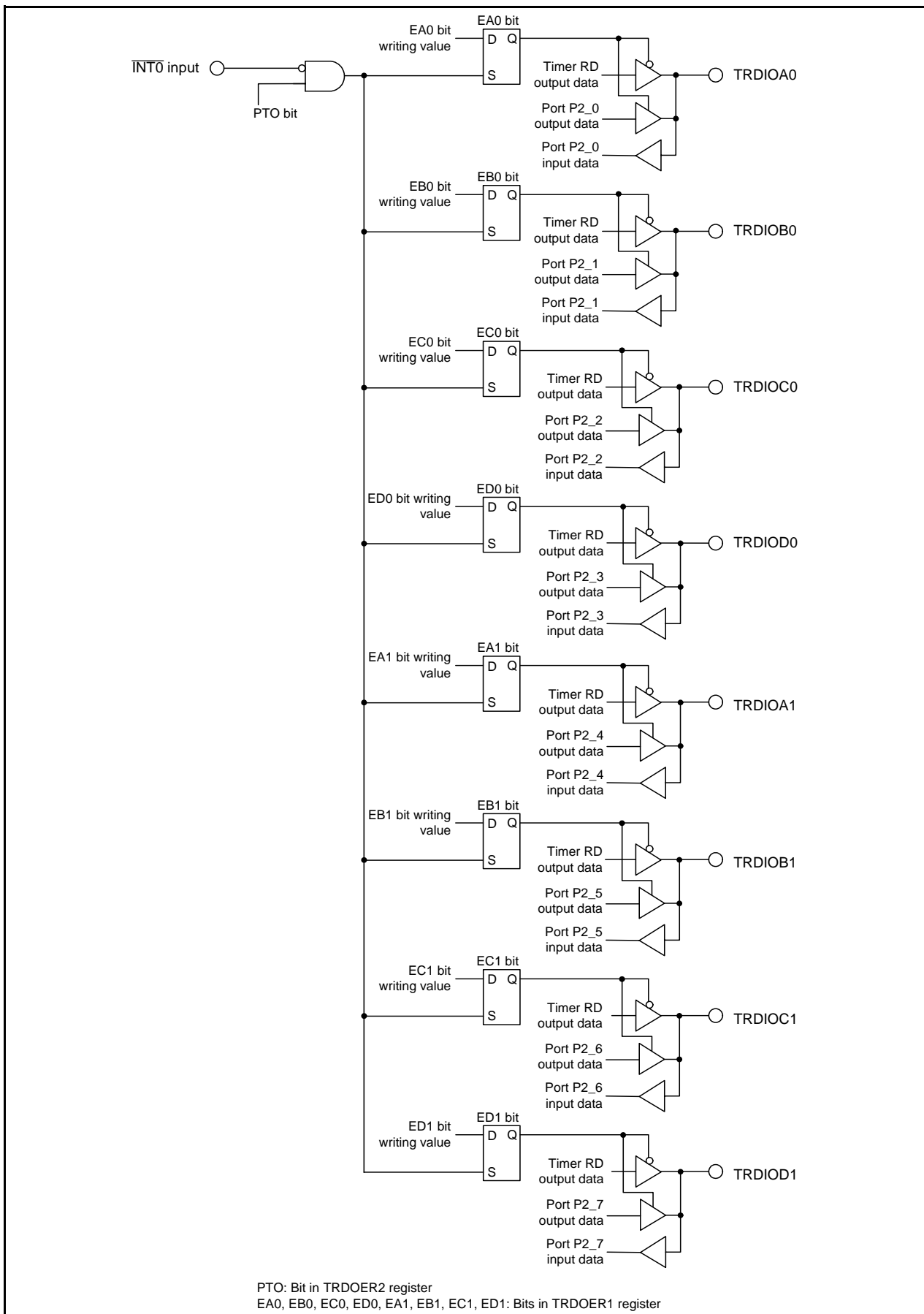

Figure 14.29 Pulse Output Forced Cutoff

14.3.5 Input Capture Function

The input capture function measures the external signal width and period. The content of the TRDi register (counter) is transferred to the TRDGRji register as a trigger of the TRDIOji (i = 0 or 1, j = either A, B, C, or D) pin external signal (input capture). Since this function is enabled with a combination of the TRDIOji pin and TRDGRji register, the input capture function, or any other mode or function, can be selected for each individual pin.

The TRDGRA0 register can also select fOCO128 signal as input-capture trigger input.

Figure 14.30 shows a Block Diagram of Input Capture Function, Table 14.23 lists the Input Capture Function Specifications. Figures 14.31 to 14.41 show the Registers Associated with Input Capture Function, and Figure 14.42 shows an Operating Example of Input Capture Function.

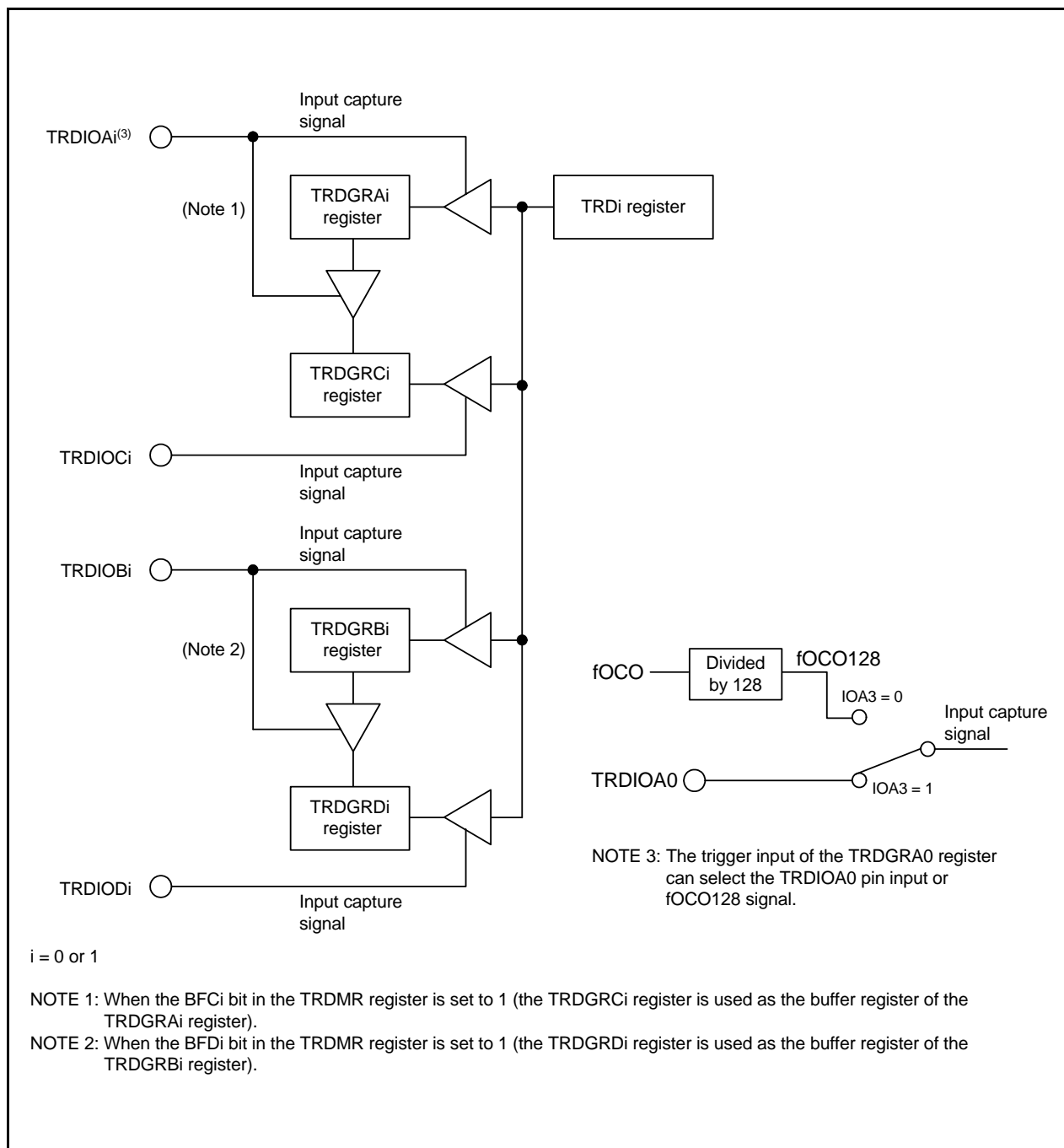

Figure 14.30 Block Diagram of Input Capture Function

Table 14.23 Input Capture Function Specifications

Item	Specification
Count sources	f1, f2, f4, f8, f32, fOCO40M External signal input to the TRDCLK pin (valid edge selected by a program)
Count operations	Increment
Count period	When bits CCLR2 to CCLR0 in the TRDCRi register are set to 000b (free-running operation). $1/fk \times 65536$ fk: Frequency of count source
Count start condition	1 (count starts) is written to the TSTARTi bit in the TRDSTR register.
Count stop condition	0 (count stops) is written to the TSTARTi bit in the TRDSTR register when the CSELi bit in the TRDSTR register is set to 1.
Interrupt request generation timing	<ul style="list-style-type: none"> Input capture (valid edge of TRDIOji input or fOCO128 signal edge) TRDi register overflows
TRDIOA0 pin function	Programmable I/O port, input-capture input, or TRDCLK (external clock) input
TRDIOB0, TRDIOC0, TRDIOD0, TRDIOA1 to TRDIOD1 pin functions	Programmable I/O port, or input-capture input (selectable by pin)
INT0 pin function	Programmable I/O port or INT0 interrupt input
Read from timer	The count value can be read by reading the TRDi register.
Write to timer	<ul style="list-style-type: none"> When the SYNC bit in the TRDMR register is set to 0 (channels 0 and 1 operate independently). Data can be written to the TRDi register. When the SYNC bit in the TRDMR register is set to 1 (channels 0 and 1 operate synchronously). Data can be written to both the TRD0 and TRD1 registers by writing to the TRDi register.
Select functions	<ul style="list-style-type: none"> Input-capture input pin selected Either 1 pin or multiple pins among TRDIOAi, TRDIOBi, TRDIOCi, or TRDIODi. Input-capture input valid edge selected The rising edge, falling edge, or both the rising and falling edges The timing when the TRDi register is set to 0000h At overflow or input capture Buffer operation (Refer to 14.3.2 Buffer Operation.) Synchronous operation (Refer to 14.3.3 Synchronous Operation.) Digital filter The TRDIOji input is sampled, and when the sampled input level match as 3 times, the level is determined. Input-capture trigger selected fOCO128 can be selected for input-capture trigger input of the TRDGRA0 register.

i = 0 or 1, j = either A, B, C, or D

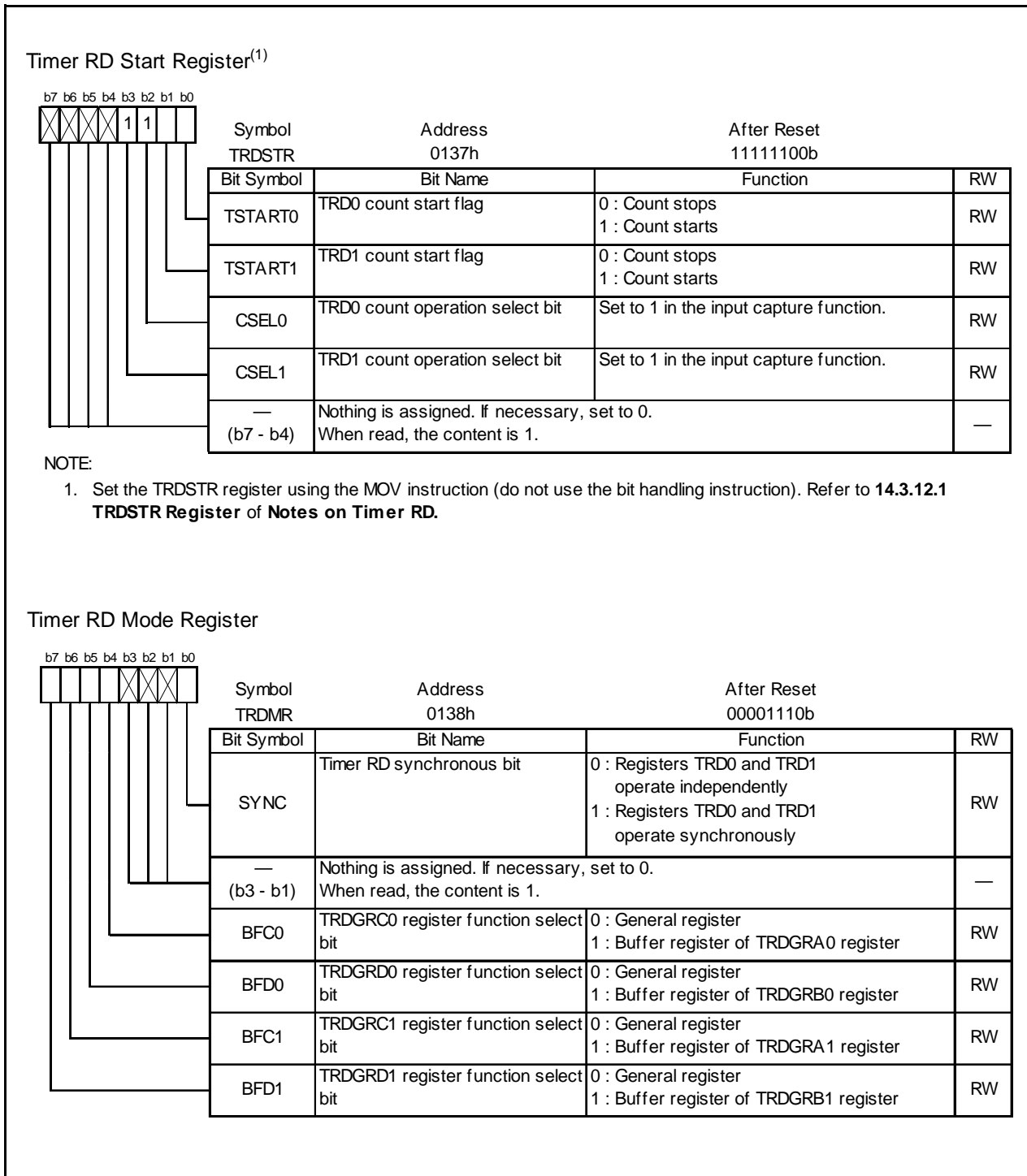

Figure 14.31 Registers TRDSTR and TRDMR in Input Capture Function

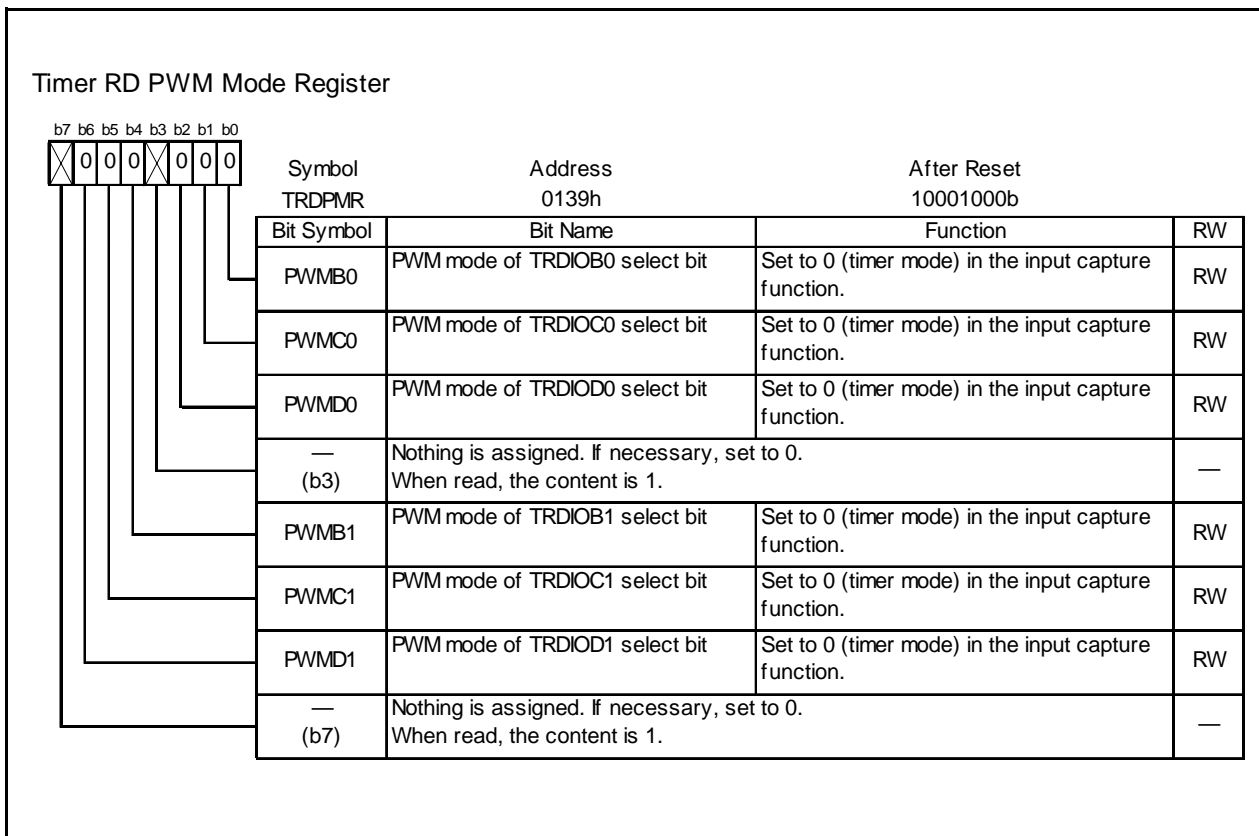

Figure 14.32 TRDPMR Register in Input Capture Function

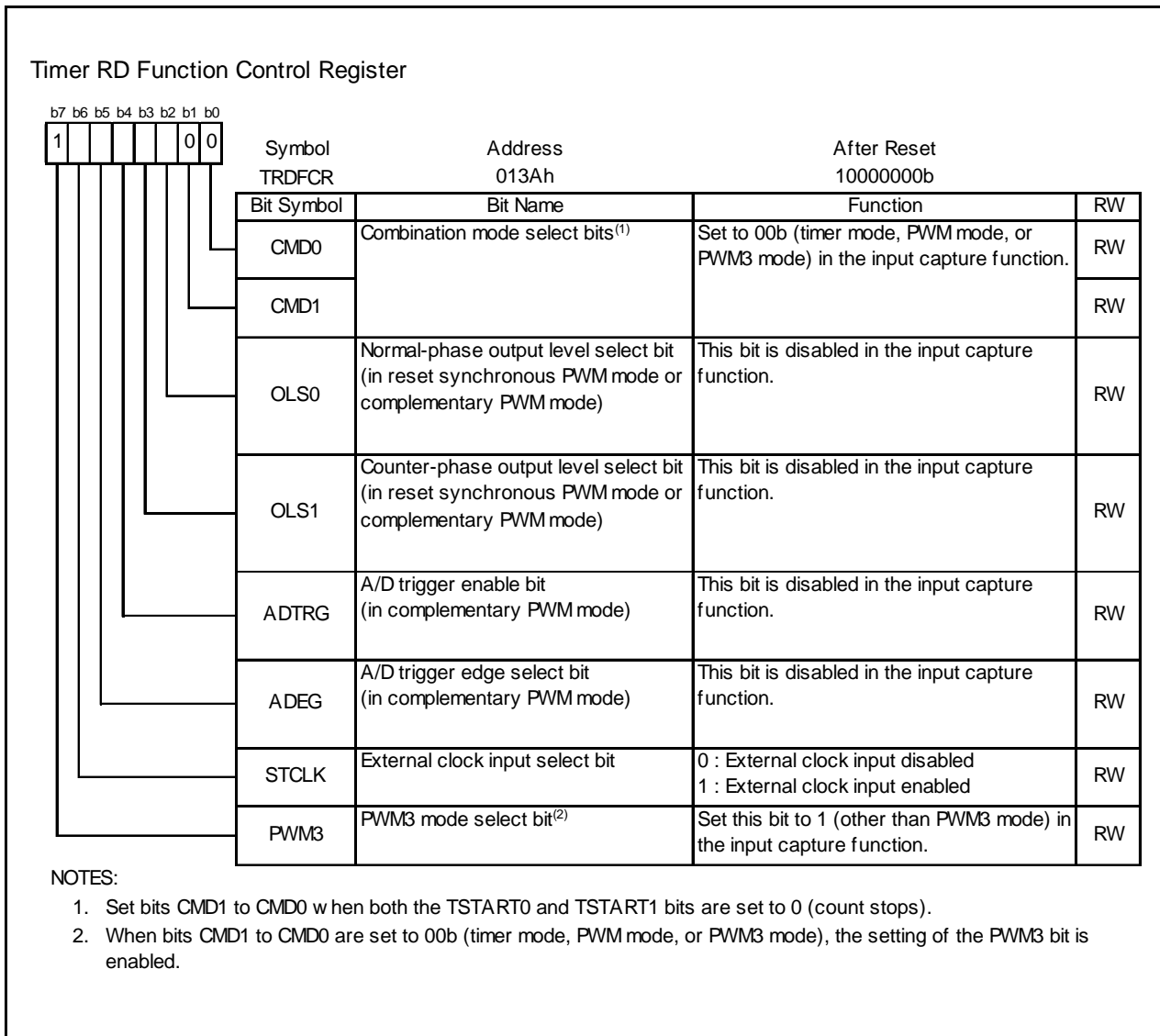

Figure 14.33 TRDFCR Register in Input Capture Function

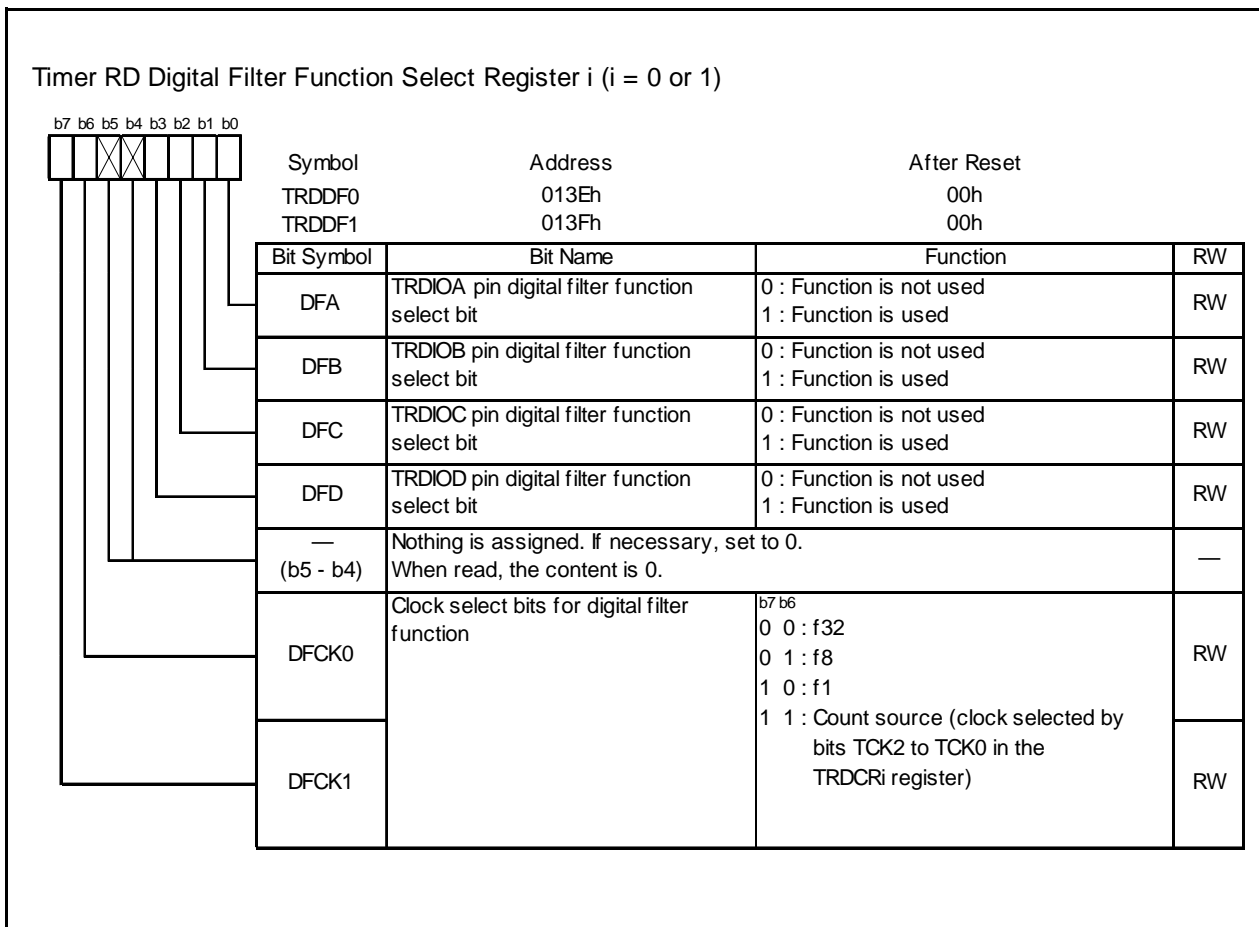

Figure 14.34 Registers TRDDF0 to TRDDF1 in Input Capture Function

Timer RD Control Register i (i = 0 or 1)

Symbol	Address	After Reset
TRDCR0	0140h	00h
TRDCR1	0150h	00h

Bit Symbol	Bit Name	Function	RW
b7 b6 b5 b4 b3 b2 b1 b0			
TCK0	Count source select bits	b2 b1 b0	RW
TCK1		0 0 0 : f1 0 0 1 : f2 0 1 0 : f4 0 1 1 : f8 1 0 0 : f32 1 0 1 : TRDCLK input ⁽¹⁾	RW
TCK2		1 1 0 : fOCO40M 1 1 1 : Do not set.	RW
CKEG0		External clock edge select bits ⁽²⁾	b4 b3
CKEG1	0 0 : Count at the rising edge 0 1 : Count at the falling edge 1 0 : Count at both edges 1 1 : Do not set.		RW
b7 b6 b5			
CCLR0	TRDi counter clear select bits	0 0 0 : Disable clear (free-running operation)	RW
CCLR1		0 0 1 : Clear by input capture in the TRDGRAi register 0 1 0 : Clear by input capture in the TRDGRBi register 0 1 1 : Synchronous clear (clear simultaneously with other channel counter) ⁽³⁾	RW
CCLR2		1 0 0 : Do not set. 1 0 1 : Clear by input capture in the TRDGRCi register 1 1 0 : Clear by input capture in the TRDGRDi register 1 1 1 : Do not set.	RW

NOTES:

1. This setting is enabled when the STCLK bit in the TRDFCR register is set to 1 (external clock input enabled).
2. Bits CKEG1 to CKEG0 are enabled when bits TCK2 to TCK0 are set to 101b (TRDCLK input) and the STCLK bit in the TRDFCR register is set to 1 (external clock input enabled).
3. This setting is enabled when the SYNC bit in the TRDMR register is set to 1 (registers TRD0 and TRD1 operate synchronously).

Figure 14.35 Registers TRDCR0 to TRDCR1 in Input Capture Function

Timer RD I/O Control Register Ai (i = 0 or 1)

Symbol	Address	After Reset
TRDIORA0	0141h	10001000b
TRDIORA1	0151h	10001000b

Bit Symbol	Bit Name	Function	RW
IOA0	TRDGRA control bits	b1 b0 0 0 : Input capture to the TRDGRAi register at the rising edge	RW
		0 1 : Input capture to the TRDGRAi register at the falling edge	
IOA1	TRDGRA control bits	1 0 : Input capture to the TRDGRAi register at both edges	RW
		1 1 : Do not set.	
IOA2	TRDGRA mode select bit ⁽¹⁾	Set to 1 (input capture) in the input capture function.	RW
IOA3	Input capture input switch bit ^(3, 4)	0 : fOCO128 Signal 1 : TRDIOA0 pin input	RW
IOB0	TRDGRB control bits	b5 b4 0 0 : Input capture to the TRDGRBi register at the rising edge	RW
		0 1 : Input capture to the TRDGRBi register at the falling edge	
IOB1	TRDGRB control bits	1 0 : Input capture to the TRDGRBi register at both edges	RW
		1 1 : Do not set.	
IOB2	TRDGRB mode select bit ⁽²⁾	Set to 1 (input capture) in the input capture function.	RW
— (b7)	Nothing is assigned. If necessary, set to 0. When read, the content is 1.		—

NOTES:

- To select 1 (the TRDGRCi register is used as a buffer register of the TRDGRAi register) for this bit by the BFCi bit in the TRDMR register, set the IOC2 bit in the TRDIORCi register to the same value as the IOA2 bit in the TRDIORAi register.
- To select 1 (the TRDGRDi register is used as a buffer register of the TRDGRBi register) for this bit by the BFDi bit in the TRDMR register, set the IOD2 bit in the TRDIORCi register to the same value as the IOB2 bit in the TRDIORAi register.
- The IOA3 bit is enabled in the TRDIORA0 register only. Set to the IOA3 bit in TRDIORA1 to 1.
- The IOA3 bit is enabled when the IOA2 bit is set to 1 (input capture function).

Figure 14.36 Registers TRDIORA0 to TRDIORA1 in Input Capture Function

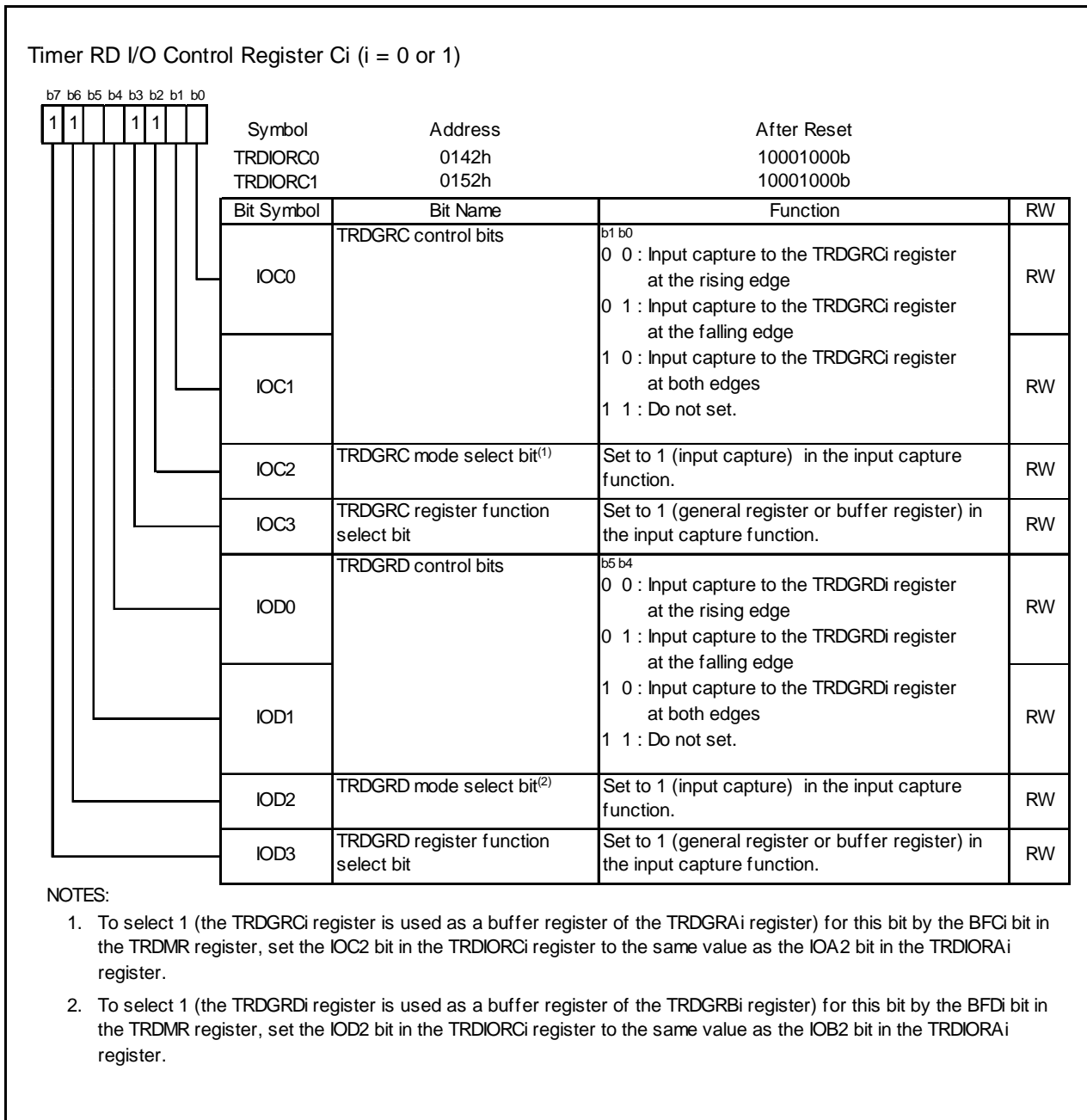

Figure 14.37 Registers TRDIORC0 to TRDIORC1 in Input Capture Function

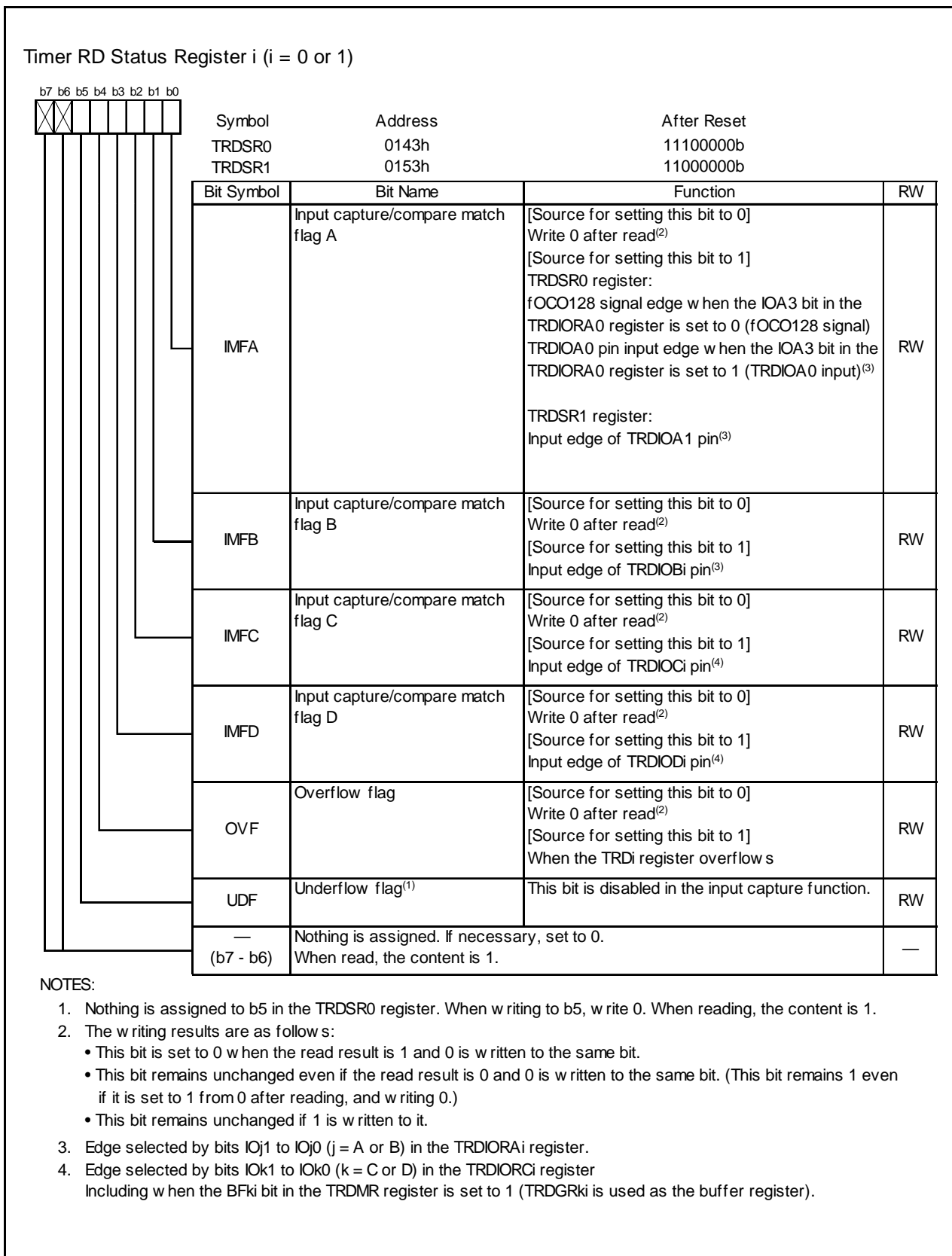

Figure 14.38 Registers TRDSR0 to TRDSR1 in Input Capture Function

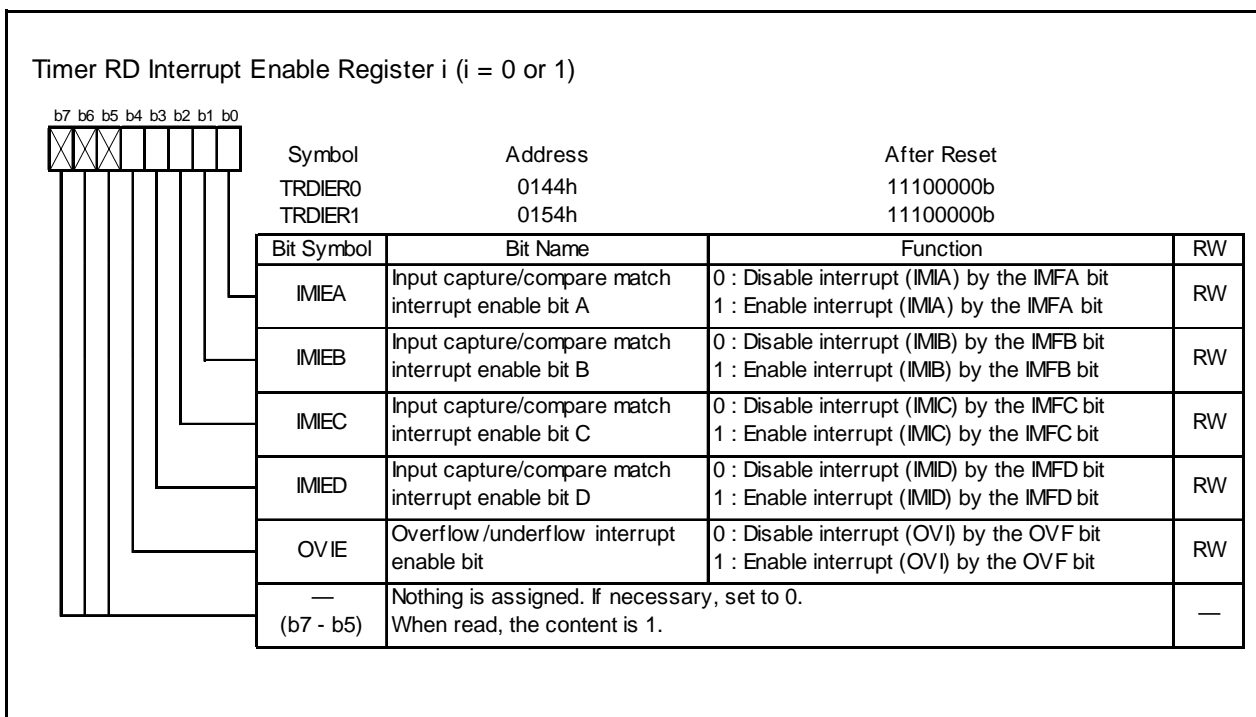

Figure 14.39 Registers TRDIER0 to TRDIER1 in Input Capture Function

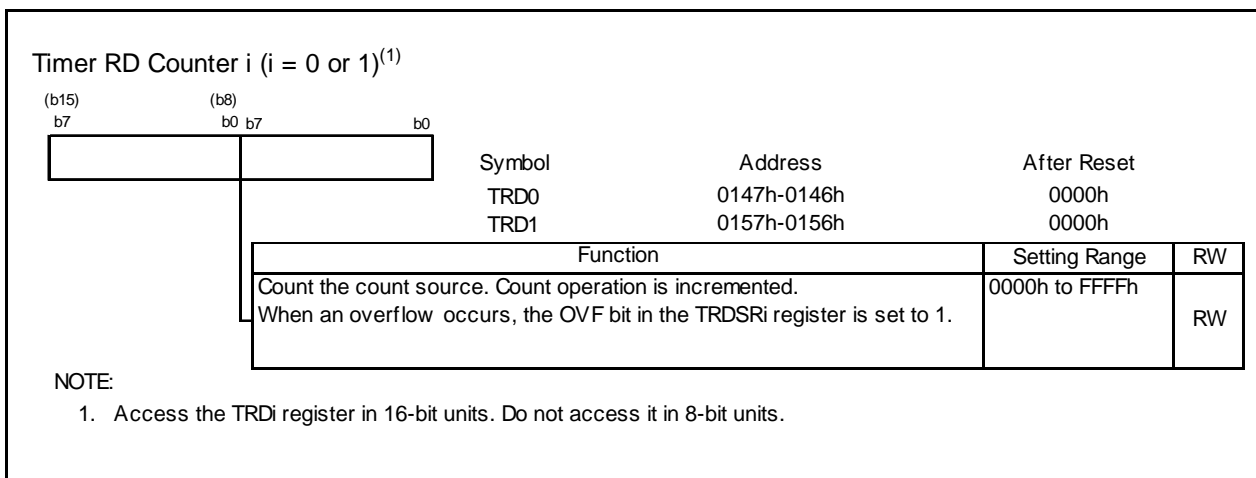

Figure 14.40 Registers TRD0 to TRD1 in Input Capture Function

Timer RD General Registers Ai, Bi, Ci, and Di (i = 0 or 1) ⁽¹⁾		Symbol	Address	After Reset
(b15) b7	(b8) b0 b7			
		TRDGRA0	0149h-0148h	FFFFh
		TRDGRB0	014Bh-014Ah	FFFFh
		TRDGRC0	014Dh-014Ch	FFFFh
		TRDGRD0	014Fh-014Eh	FFFFh
		TRDGRA1	0159h-0158h	FFFFh
		TRDGRB1	015Bh-015Ah	FFFFh
		TRDGRC1	015Dh-015Ch	FFFFh
		TRDGRD1	015Fh-015Eh	FFFFh
Function				RW
Refer to Table 14.24 TRDGRji Register Functions in Input Capture Function				RW

NOTE:

- Access registers TRDGRAi to TRDGRDi in 16-bit units. Do not access them in 8-bit units.

Figure 14.41 Registers TRDGRAi, TRDGRBi, TRDGRCi, and TRDGRDi in Input Capture Function

The following registers are disabled in the input capture function: TRDOER1, TRDOER2, TRDOCR, TRDPOCR0, and TRDPOCR1.

Table 14.24 TRDGRji Register Functions in Input Capture Function

Register	Setting	Register Function	Input-Capture Input Pin
TRDGRAi	–	General register The value in the TRDi register can be read at input capture.	TRDIOAi
TRDGRBi			TRDIOBi
TRDGRCi	BFCi = 0	General register The value in the TRDi register can be read at input capture.	TRDIOCi
TRDGRDi	BFDi = 0		TRDIODi
TRDGRCi	BFCi = 1	Buffer register The value in the TRDi register can be read at input capture. (Refer to 14.3.2 Buffer Operation)	TRDIOAi
TRDGRDi	BFDi = 1		TRDIOBi

i = 0 or 1, j = either A, B, C, or D

BFCi, BFDi: Bits in TRDMR register

Set the pulse width of the input capture signal applied to the TRDIOji pin to 3 cycles or more of the timer RD operation clock (refer to Table 14.11 Timer RD Operation Clocks) for no digital filter (the DFj bit in the TRDDFi register set to 0).

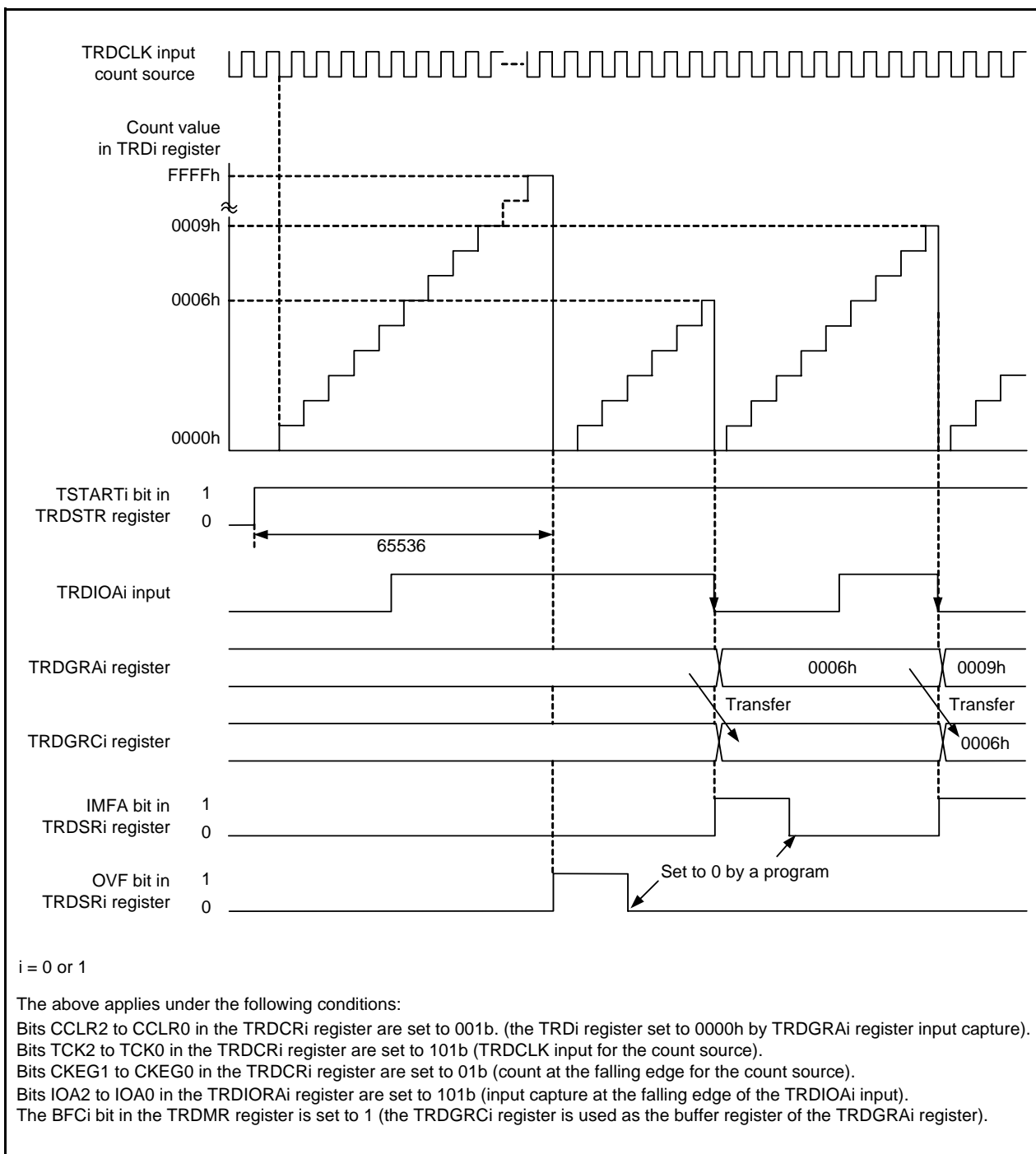

Figure 14.42 Operating Example of Input Capture Function

14.3.5.1 Digital Filter

The TRDIO_{ji} input is sampled, and when the sampled input level matches 3 times, its level is determined. Select the digital filter function and sampling clock by the TRDDF_i register.

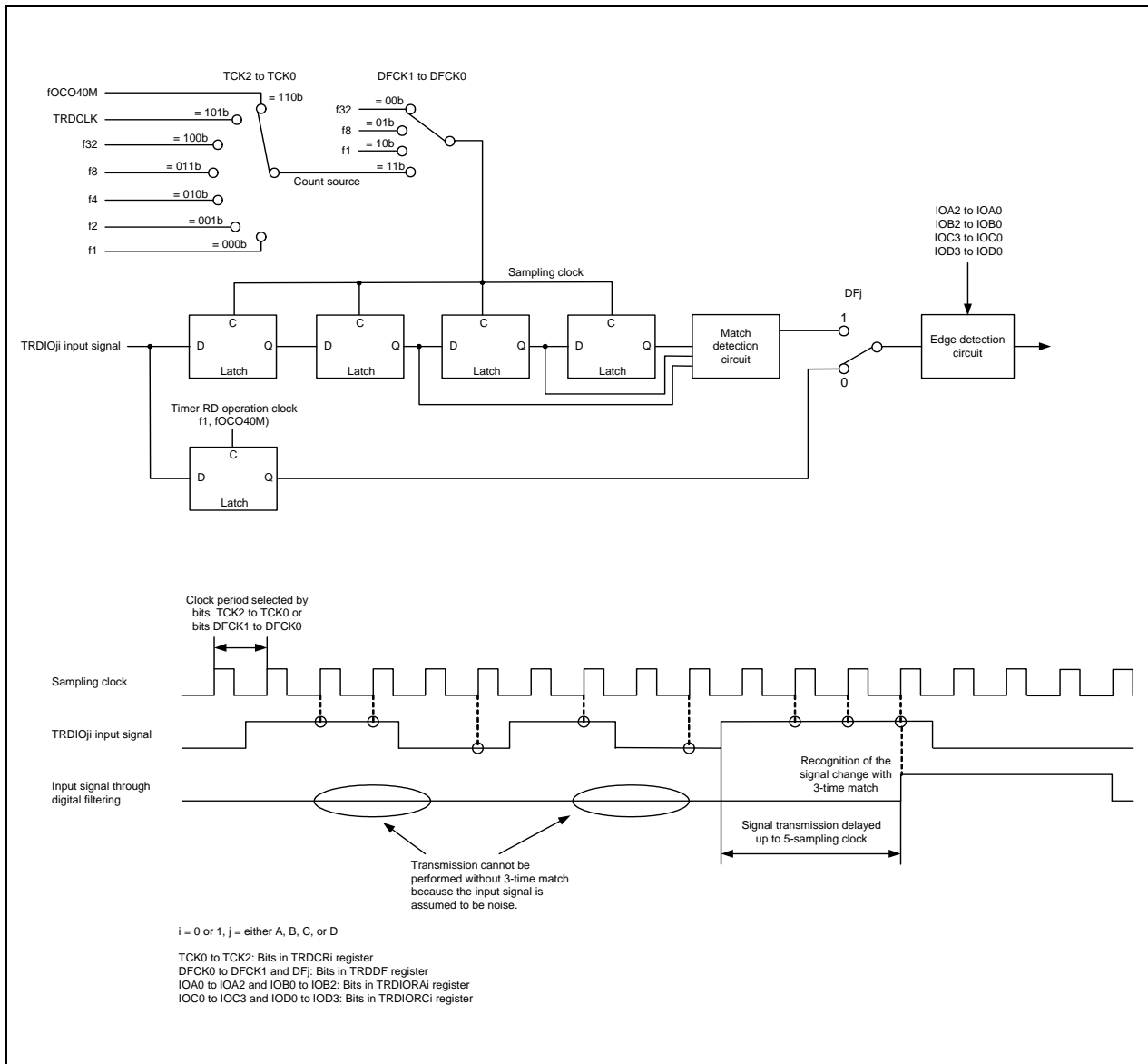

Figure 14.43 Block Diagram of Digital Filter

14.3.6 Output Compare Function

This function detects matches (compare match) between the content of the TRDGR_{ji} (j = either A, B, C, or D) register and the content of the TRD_i (i = 0 or 1) register. When the content matches, a user-set level is output from the TRDIO_{ji} pin. Since this function is enabled with a combination of the TRDIO_{ji} pin and TRDGR_{ji} register, the output compare function, or any other mode or function, can be selected for each individual pin. Figure 14.44 shows a Block Diagram of Output Compare Function, Table 14.25 lists the Output Compare Function Specifications. Figures 14.45 to 14.56 list the Registers Associated with Output Compare Function, and Figure 14.57 shows an Operating Example of Output Compare Function.

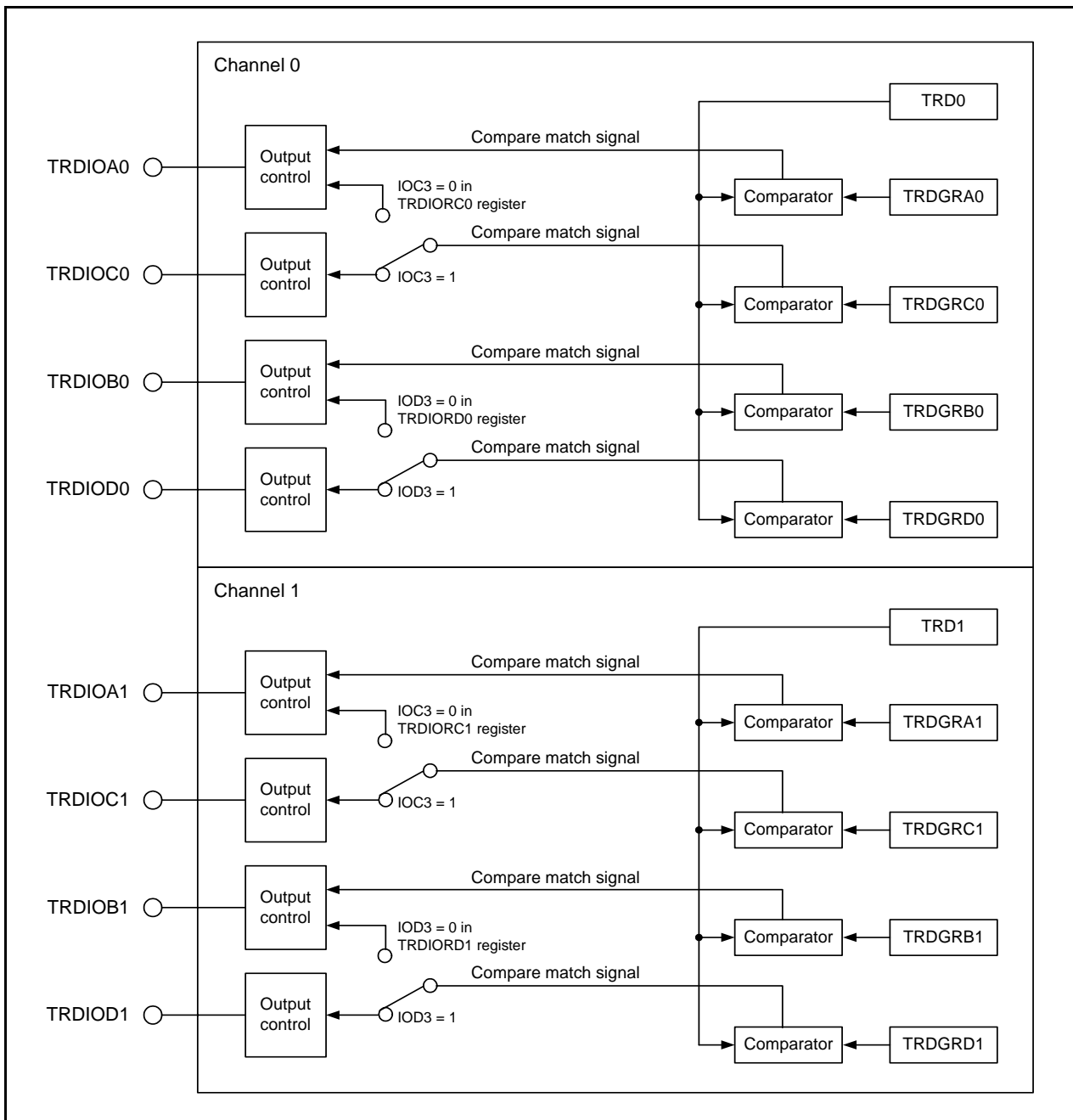

Figure 14.44 Block Diagram of Output Compare Function

Table 14.25 Output Compare Function Specifications

Item	Specification
Count sources	f1, f2, f4, f8, f32, fOCO40M External signal input to the TRDCLK pin (valid edge selected by a program)
Count operations	Increment
Count period	<ul style="list-style-type: none"> When bits CCLR2 to CCLR0 in the TRDCRi register are set to 000b (free-running operation) 1/fk × 65536 fk: Frequency of count source Bits CCLR1 to CCLR0 in the TRDCRi register are set to 01b or 10b (set the TRDi register to 0000h at the compare match in the TRDGRji register). Frequency of count source × (n+1) n: Setting value in the TRDGRji register
Waveform output timing	Compare match
Count start condition	1 (count starts) is written to the TSTARTi bit in the TRDSTR register.
Count stop conditions	<ul style="list-style-type: none"> 0 (count stops) is written to the TSTARTi bit in the TRDSTR register when the CSELi bit in the TRDSTR register is set to 1. The output compare output pin holds output level before the count stops. When the CSELi bit in the TRDSTR register is set to 0, the count stops at the same time as the TRDi register is set to 0000h at the compare match in the TRDGRAi register. The output compare output pin holds level after output change by the compare match.
Interrupt request generation timing	<ul style="list-style-type: none"> Compare match (content of the TRDi register matches content of the TRDGRji register.) TRDi register overflows
TRDIOA0 pin function	Programmable I/O port, output-compare output, or TRDCLK (external clock) input
TRDIOB0, TRDIOC0, TRDIOD0, TRDIOA1 to TRDIOD1 pin functions	Programmable I/O port or output-compare output (Selectable by pin)
INT0 pin function	Programmable I/O port, pulse output forced cutoff signal input, or INT0 interrupt input
Read from timer	The count value can be read by reading the TRDi register.
Write to timer	<ul style="list-style-type: none"> When the SYNC bit in the TRDMR register is set to 0 (channels 0 and 1 operate independently). Data can be written to the TRDi register. When the SYNC bit in the TRDMR register is set to 1 (channels 0 and 1 operate synchronously). Data can be written to both the TRD0 and TRD1 registers by writing to the TRDi register.
Select functions	<ul style="list-style-type: none"> Output-compare output pin selected Either 1 pin or multiple pins among TRDIOAi, TRDIOBi, TRDIOCi, or TRDIODi. Output level at the compare match selected “L” output, “H” output, or output level inversed Initial output level selected Set the level at period from the count start to the compare match. Timing to set the TRDi register to 0000h Overflow or compare match in the TRDGRAi register Buffer operation (Refer to 14.3.2 Buffer Operation.) Synchronous operation (Refer to 14.3.3 Synchronous Operation.) Output pin in registers TRDGRCi and TRDGRDi changed The TRDGRCi register can be used as output control of the TRDIOAi pin and the TRDGRDi register can be used as output control of the TRDIOBi pin. Pulse output forced cutoff signal input (Refer to 14.3.4 Pulse Output Forced Cutoff.) Timer RD can be used as the internal timer without output.

i = 0 or 1, j = either A, B, C, or D

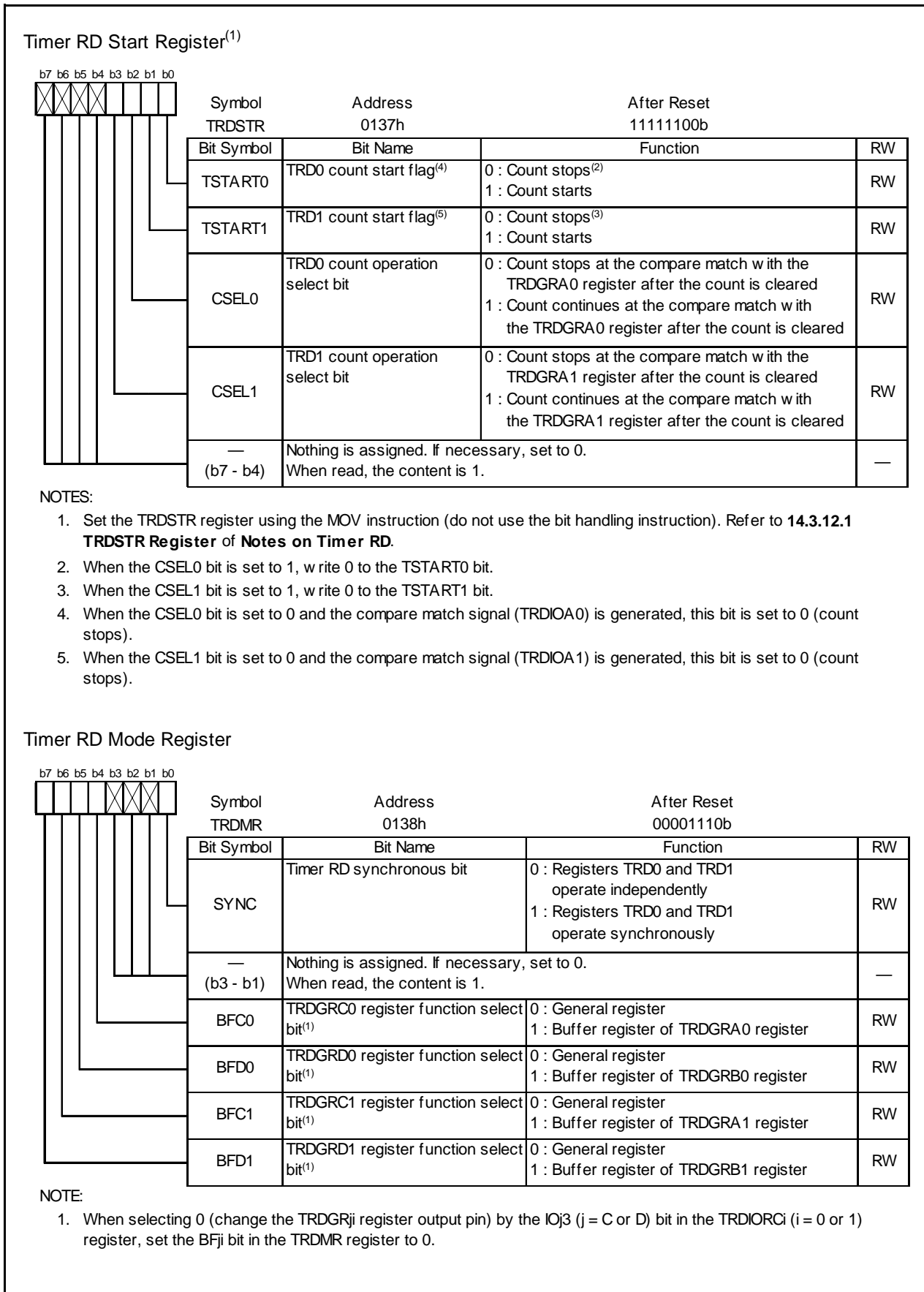

Figure 14.45 Registers TRDSTR and TRDMR in Output Compare Function

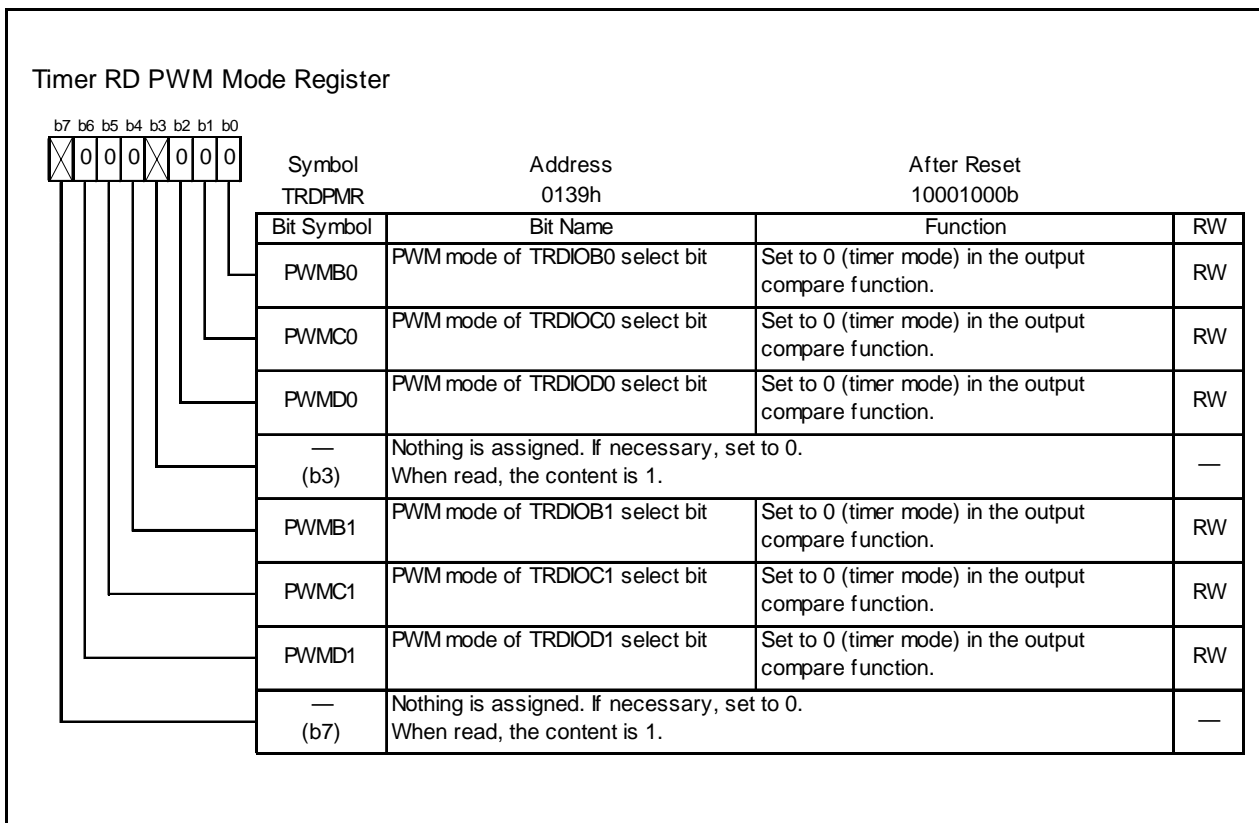

Figure 14.46 TRDPMR Register in Output Compare Function

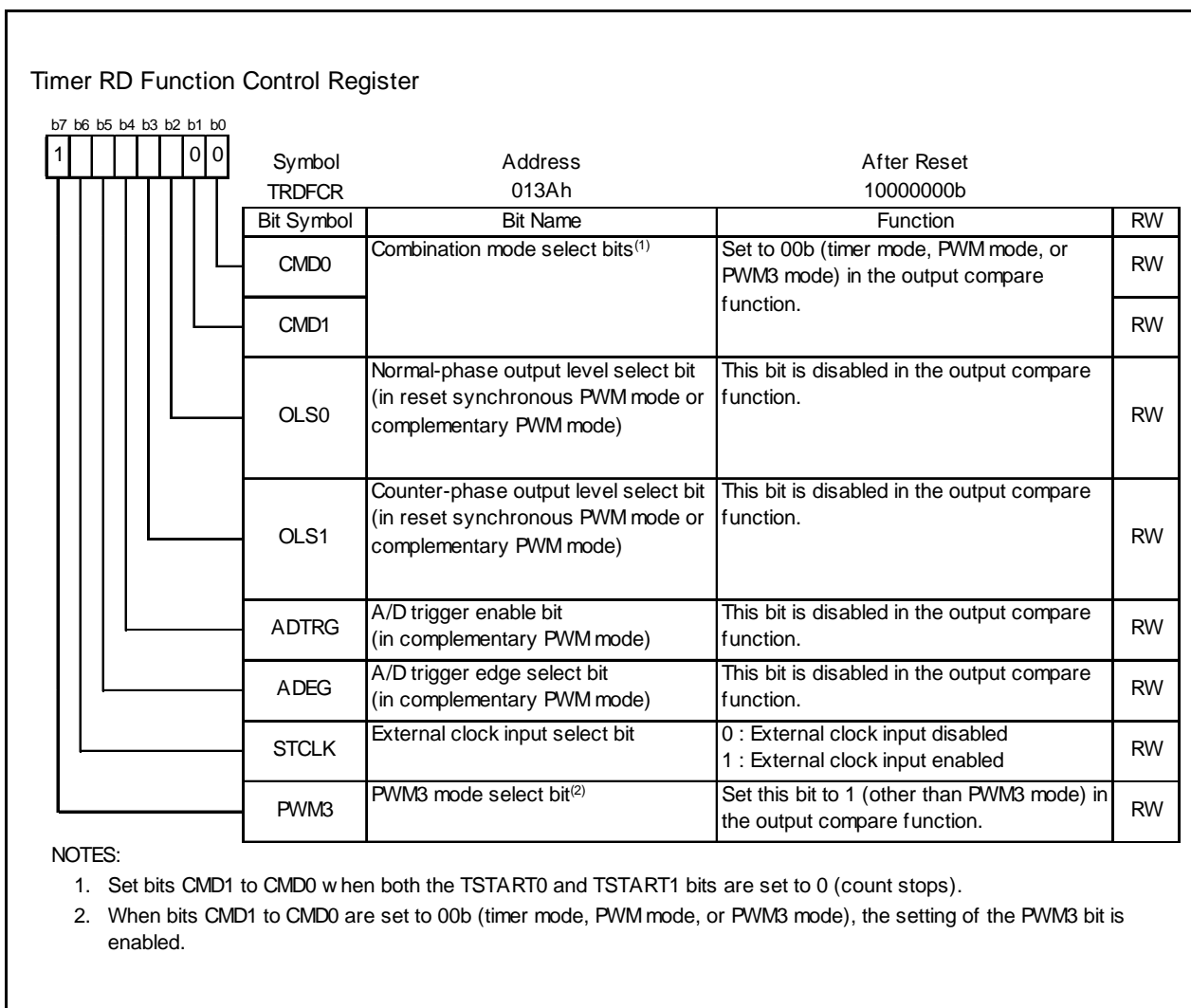

Figure 14.47 TRDFCR Register in Output Compare Function

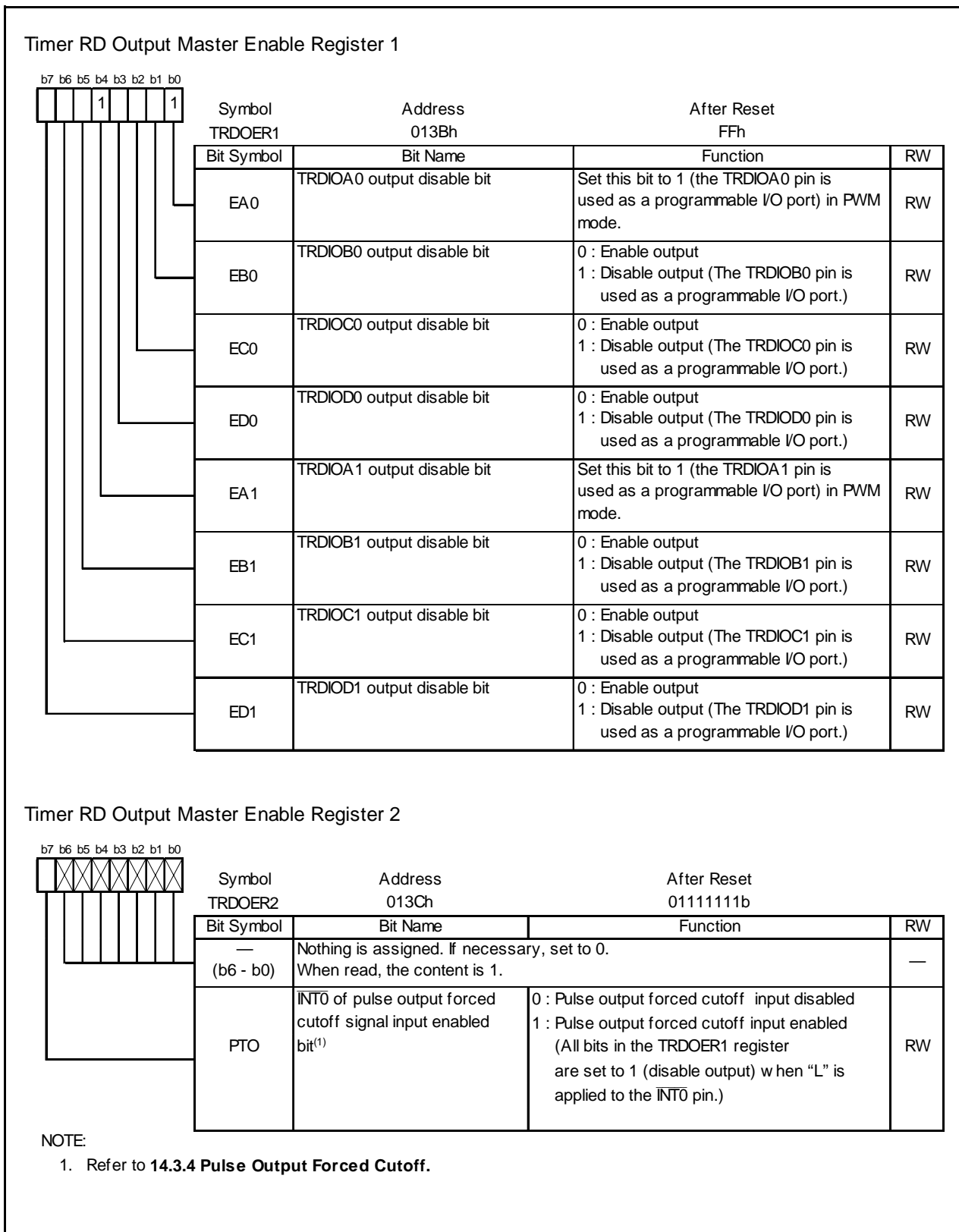

Figure 14.48 Registers TRDOER1 to TRDOER2 in Output Compare Function

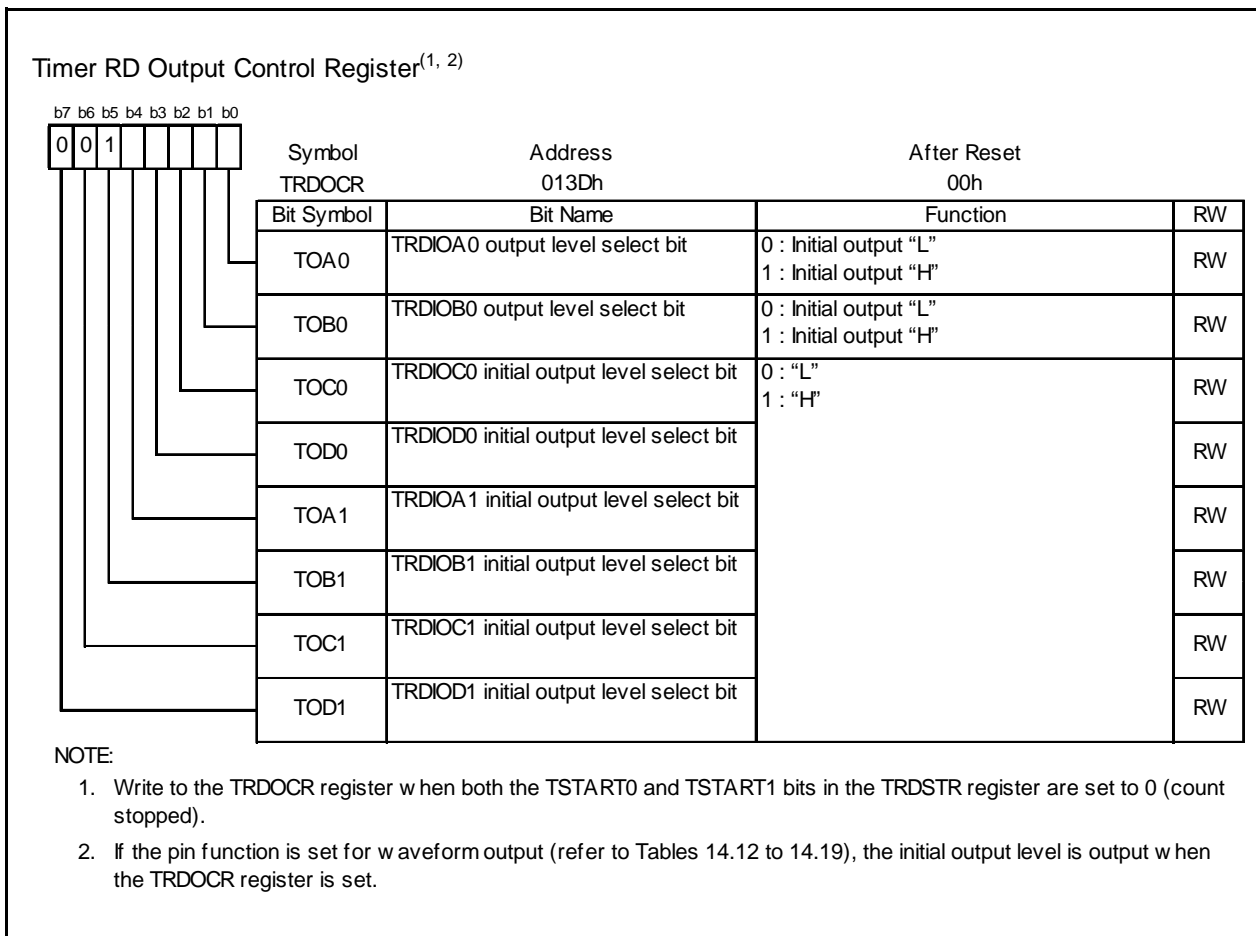

Figure 14.49 TRDOCR Register in Output Compare Function

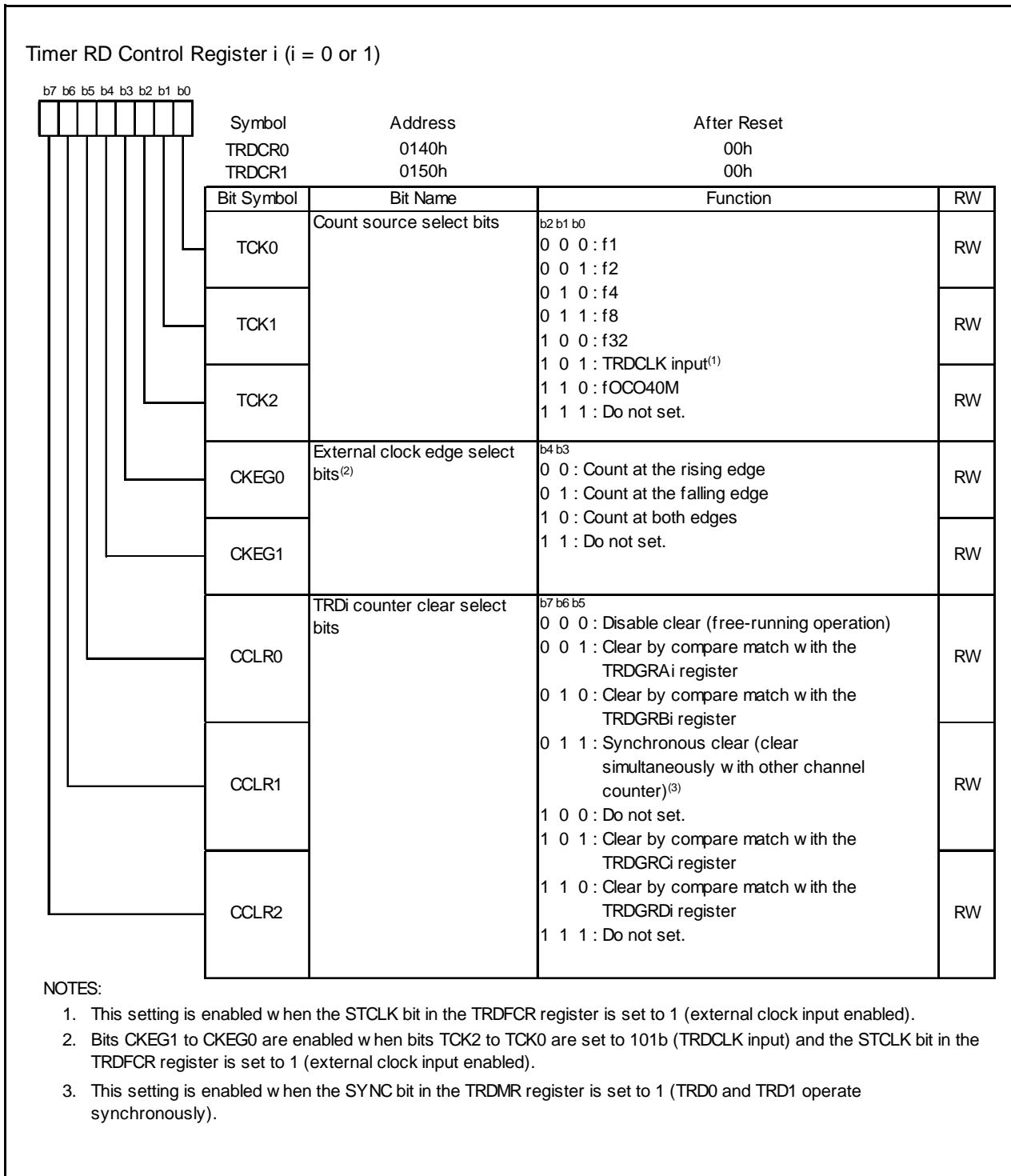

Figure 14.50 Registers TRDCR0 to TRDCR1 in Output Compare Function

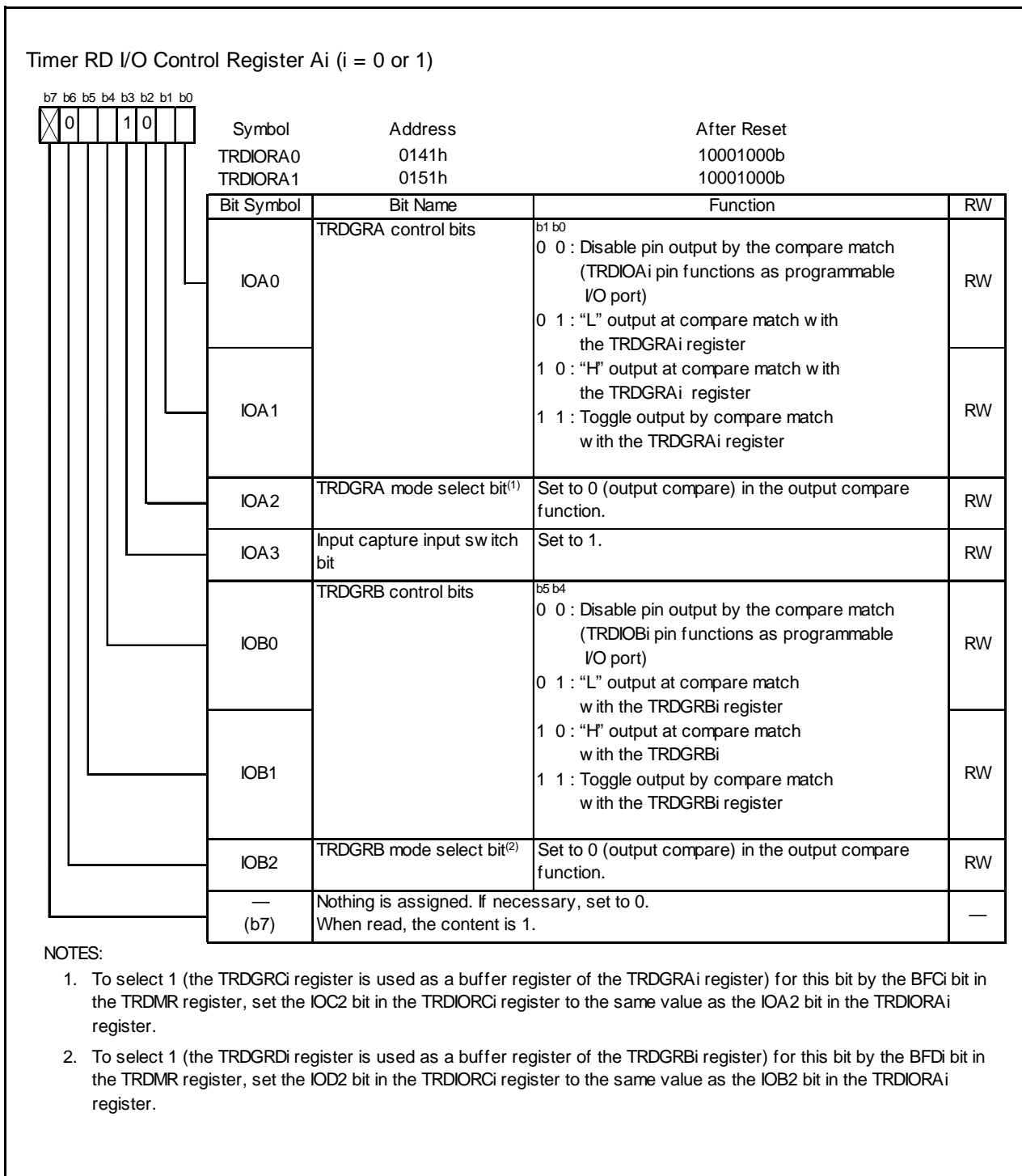

Figure 14.51 Registers TRDIORA0 to TRDIORA1 in Output Compare Function

Timer RD I/O Control Register Ci (i = 0 or 1)

Bit	Symbol	Address	After Reset
b7	0		
b6			
b5			
b4			
b3	0		
b2			
b1			
b0			
	Symbol	Address	After Reset
	TRDIORC0	0142h	10001000b
	TRDIORC1	0152h	10001000b

Bit Symbol	Bit Name	Function	RW
IOC0	TRDGRC control bits	b1 b0 0 0 : Disable pin output by compare match 0 1 : "L" output at compare match with the TRDGRCi register 1 0 : "H" output at compare match with the TRDGRCi register 1 1 : Toggle output by compare match with the TRDGRCi register	RW
			RW
IOC2	TRDGRC mode select bit ⁽¹⁾	Set to 0 (output compare) in the output compare function.	RW
IOC3	TRDGRC register function select bit	0 : TRDIOA output register (Refer to 14.3.6.1 Change Output Pin in Registers TRDGRCi (i = 0 or 1) and TRDGRDi.) 1 : General register or buffer register	RW
IOD0	TRDGRD control bits	b5 b4 0 0 : Disable pin output by compare match 0 1 : "L" output at compare match with the TRDGRDi register 1 0 : "H" output at compare match with the TRDGRDi register 1 1 : Toggle output by compare match with the TRDGRDi register	RW
			RW
IOD2	TRDGRD mode select bit ⁽²⁾	Set to 0 (output compare) in the output compare function.	RW
IOD3	TRDGRD register function select bit	0 : TRDIOB output register (Refer to 14.3.6.1 Change Output Pin in Registers TRDGRCi (i = 0 or 1) and TRDGRDi.) 1 : General register or buffer register	RW

NOTES:

- To select 1 (the TRDGRCi register is used as a buffer register of the TRDGRAi register) for this bit by the BFCi bit in the TRDMR register, set the IOC2 bit in the TRDIORCi register to the same value as the IOA2 bit in the TRDIOA_i register.
- To select 1 (the TRDGRDi register is used as a buffer register of the TRDGRBi register) for this bit by the BFDi bit in the TRDMR register, set the IOD2 bit in the TRDIORCi register to the same value as the IOB2 bit in the TRDIOA_i register.

Figure 14.52 Registers TRDIORC0 to TRDIORC1 in Output Compare Function

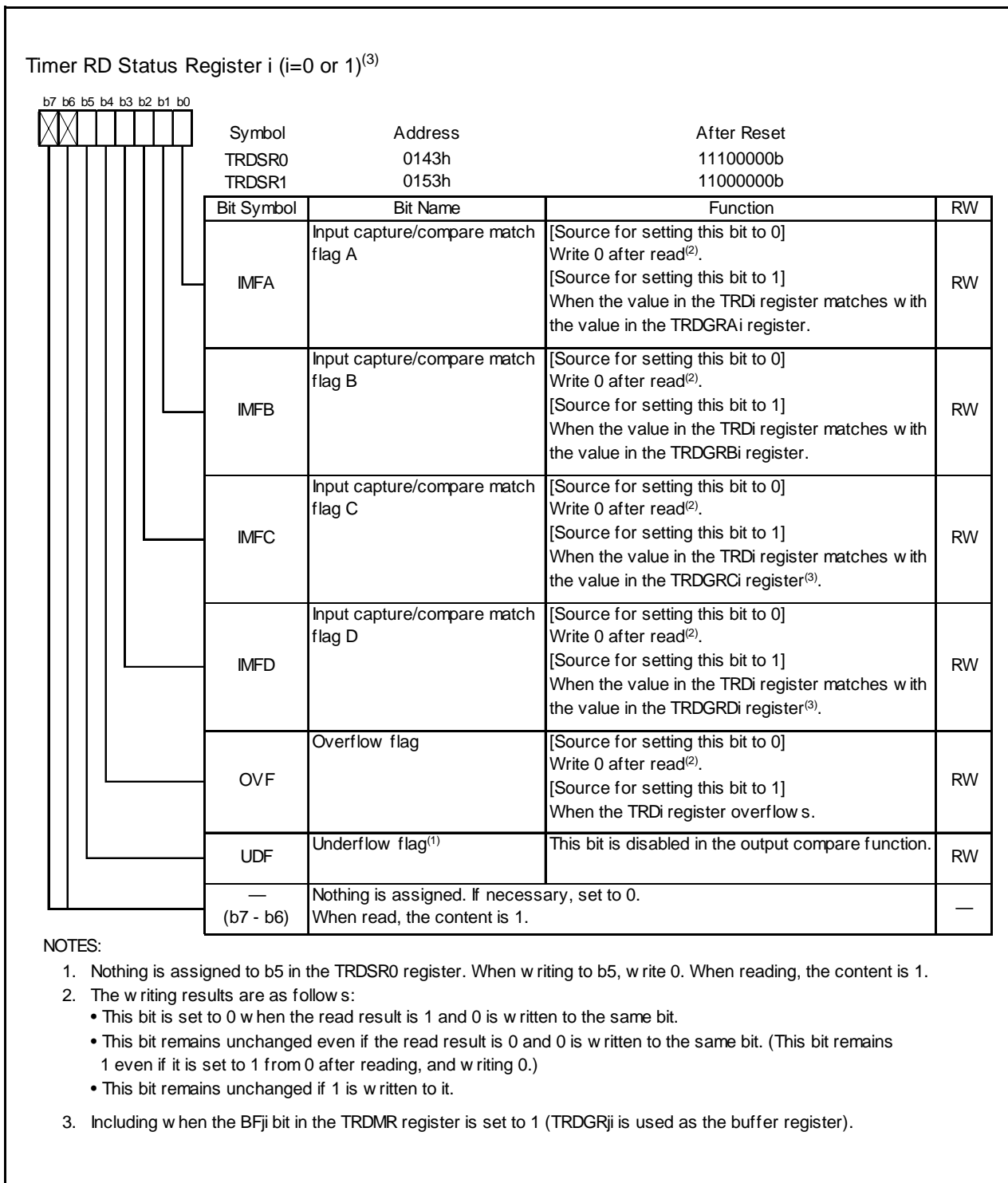

Figure 14.53 Registers TRDSR0 to TRDSR1 in Output Compare Function

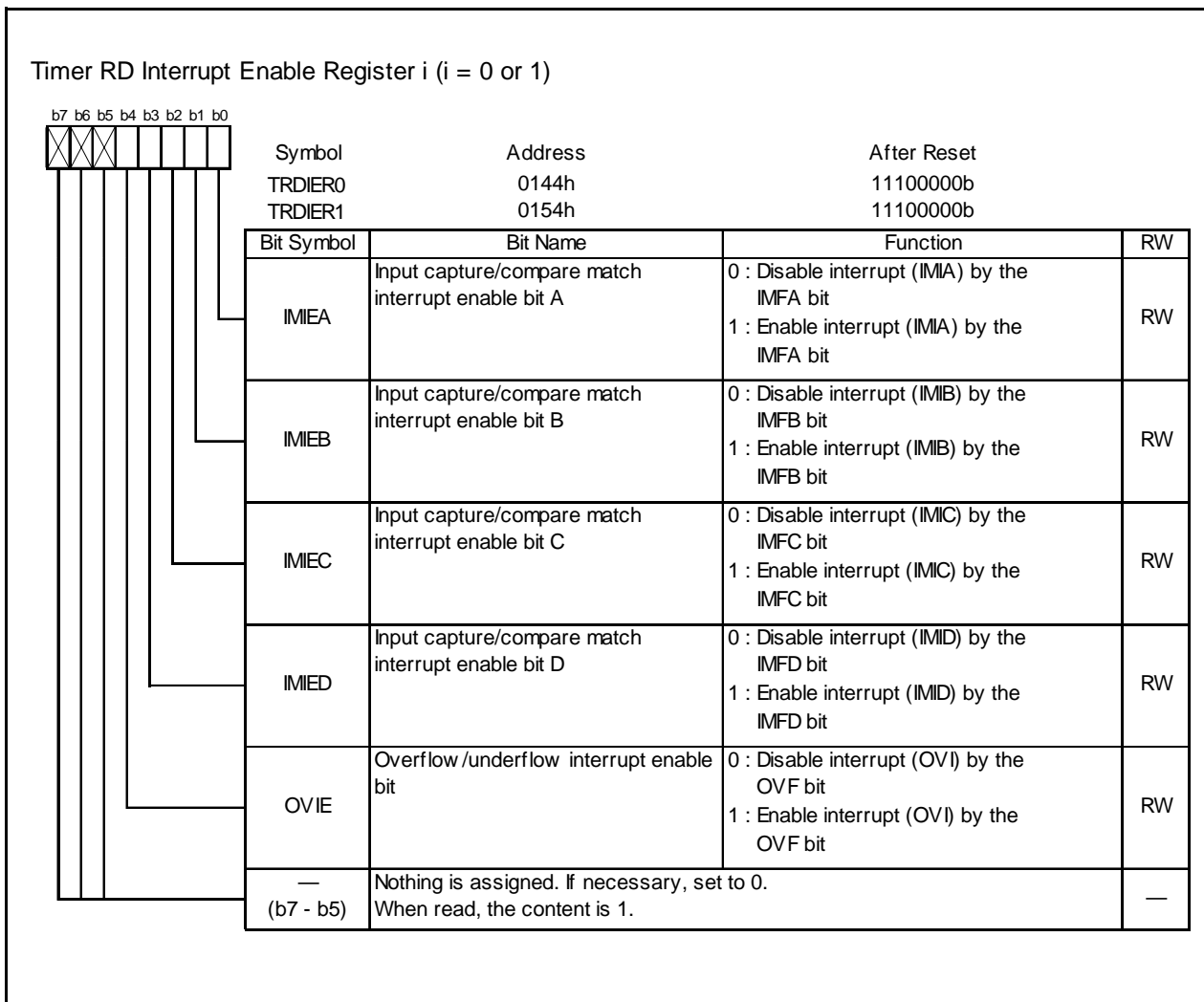

Figure 14.54 Registers TRDIER0 to TRDIER1 in Output Compare Function

Timer RD Counter i ($i = 0$ or 1) ⁽¹⁾					
(b15) b7	(b8) b0	Symbol	Address	After Reset	
		TRD0	0147h-0146h	0000h	
		TRD1	0157h-0156h	0000h	
Function				Setting Range	RW
Count a count source. Count operation is incremented.				0000h to FFFFh	RW
When an overflow occurs, the OVF bit in the TRDSR i register is set to 1.					RW

NOTE:

- Access the TRD i register in 16-bit units. Do not access it in 8-bit units.

Figure 14.55 Registers TRD0 to TRD1 in Output Compare Function

Timer RD General Register A_i , B_i , C_i and D_i ($i = 0$ or 1) ⁽¹⁾				
(b15) b7	(b8) b0	Symbol	Address	After Reset
		TRDGRA0	0149h-0148h	FFFFh
		TRDGRB0	014Bh-014Ah	FFFFh
		TRDGRC0	014Dh-014Ch	FFFFh
		TRDGRD0	014Fh-014Eh	FFFFh
		TRDGRA1	0159h-0158h	FFFFh
		TRDGRB1	015Bh-015Ah	FFFFh
		TRDGRC1	015Dh-015Ch	FFFFh
		TRDGRD1	015Fh-015Eh	FFFFh
Function				RW
Refer to Table 14.26 TRDGR j_i Register Function in Output Compare Function				RW

NOTE:

- Access registers TRDGRA i to TRDGRD i in 16-bit units. Do not access them in 8-bit units.

Figure 14.56 Registers TRDGRA i , TRDGRB i , TRDGRC i , and TRDGRD i in Output Compare Function

The following registers are disabled in the output compare function: TRDDF0, TRDDF1, TRDPOCR0, and TRDPOCR1.

Table 14.26 TRDGR j_i Register Function in Output Compare Function

Register	Setting		Register Function	Output-Compare Output Pin
	BF j_i	IO j_3		
TRDGRA i	–	–	General register. Write the compare value.	TRDIOA i
TRDGRB i				TRDIOB i
TRDGRC i	0	1	General register. Write the compare value.	TRDIOC i
TRDGRD i				TRDIOD i
TRDGRC i	1	1	Buffer register. Write the next compare value (Refer to 14.3.2 Buffer Operation.)	TRDIOA i
TRDGRD i				TRDIOB i
TRDGRC i	0	0	TRDIOA i output control (Refer to 14.3.6.1 Changing Output Pins in Registers TRDGRC i ($i = 0$ or 1) and TRDGRD i .)	TRDIOA i
TRDGRD i				TRDIOB i

$i = 0$ or 1 , $j =$ either A, B, C, or D

BF j_i : Bit in TRDMR register

IO j_3 : Bit in TRDIORC i register

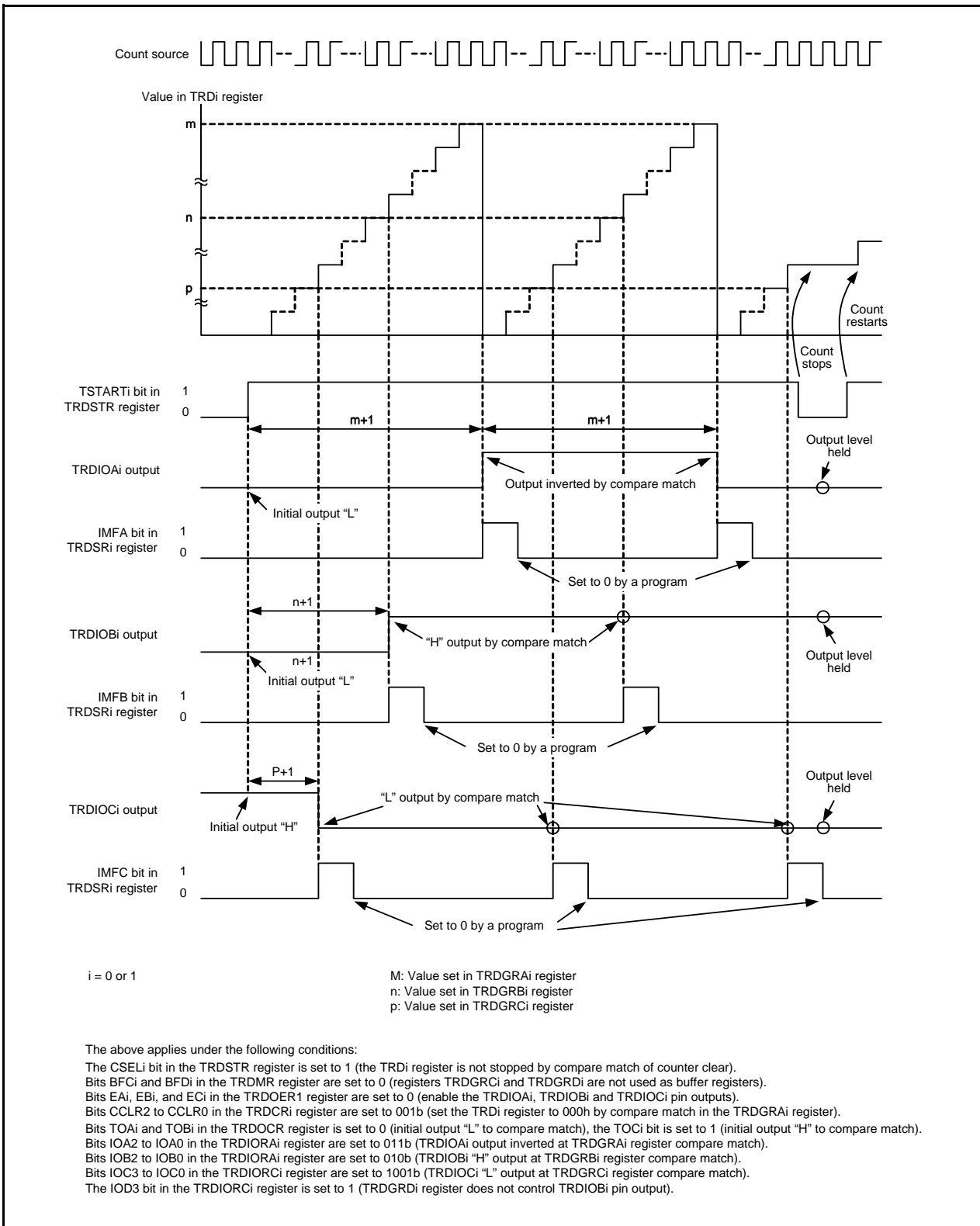

Figure 14.57 Operating Example of Output Compare Function

14.3.6.1 Changing Output Pins in Registers TRDGRCi (i = 0 or 1) and TRDGRDi

The TRDGRCi register can be used for output control of the TRDIOAi pin, and the TRDGRDi register can be used for output control of the TRDIOBi pin. Therefore, each pin output can be controlled as follows:

- TRDIOAi output is controlled by the values in registers TRDGRAi and TRDGRCi.
- TRDIOBi output is controlled by the values in registers TRDGRBi and TRDGRDi.

Change output pins in registers TRDGRCi and TRDGRDi as follows:

- Select 0 (change TRDGRji register output pin) by the IOj3 (j = C or D) bit in the TRDIORCi register.
- Set the BFji bit in the TRDMR register to 0 (general register).
- Set different values in registers TRDGRCi and TRDGRAi. Also, set different values in registers TRDGRDi and TRDGRBi.

Figure 14.59 shows an Operating Example When TRDGRCi Register is Used for Output Control of TRDIOAi Pin and TRDGRDi Register is Used for Output Control of TRDIOBi Pin.

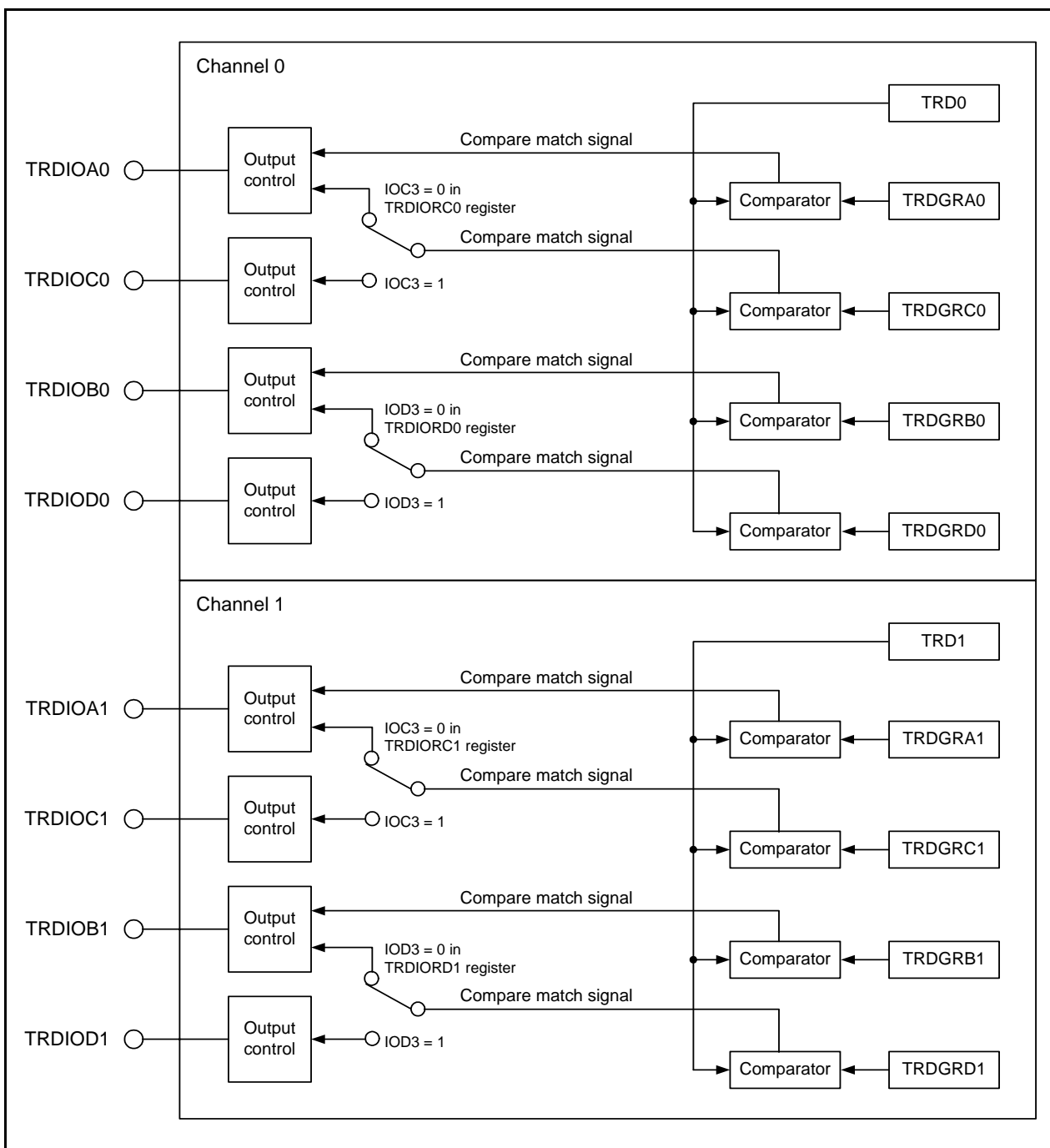

Figure 14.58 Changing Output Pins in Registers TRDGRCi and TRDGRDi

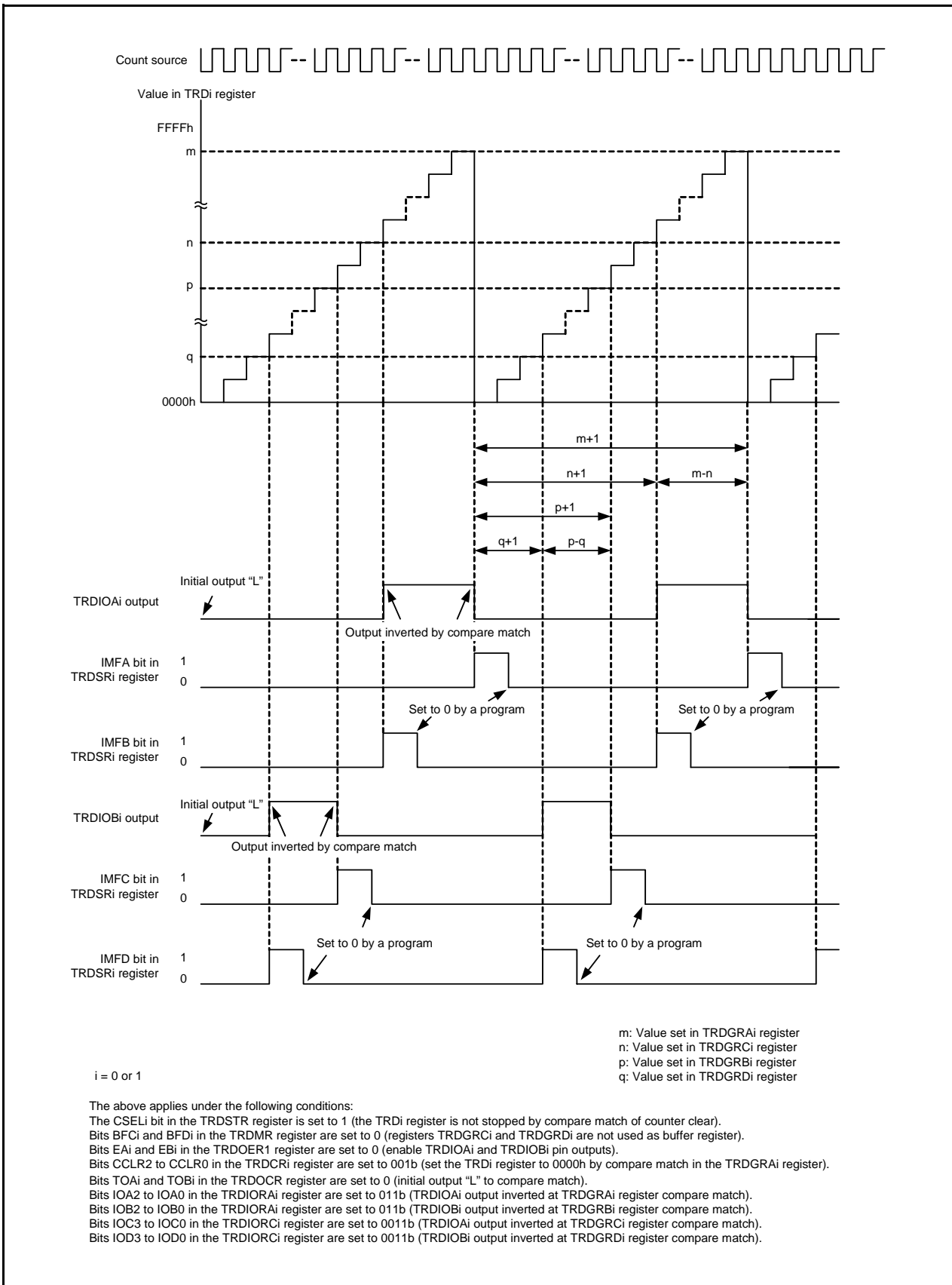

Figure 14.59 Operating Example When TRDGRCi Register is Used for Output Control of TRDIOAi Pin and TRDGRDi Register is Used for Output Control of TRDIOBi Pin

14.3.7 PWM Mode

In PWM mode, a PWM waveform is output. Up to 3 PWM waveforms with the same period can be output by 1 channel. Also, up to 6 PWM waveforms with the same period can be output by synchronizing channels 0 and 1. Since this mode functions by a combination of the TRDIO_j ($i = 0$ or 1 , $j = B, C,$ or D) pin and TRDGR_j register, the PWM mode, or any other mode or function, can be selected for each individual pin. (However, since the TRDGRA_i register is used when using any pin for PWM mode, the TRDGRA_i register cannot be used for other modes.)

Figure 14.60 shows a Block Diagram of PWM Mode, and Table 14.27 lists the PWM Mode Specifications. Figures 14.61 to 14.70 show the Registers Associated with PWM Mode, and Figures 14.71 and 14.72 show the Operations of PWM Mode.

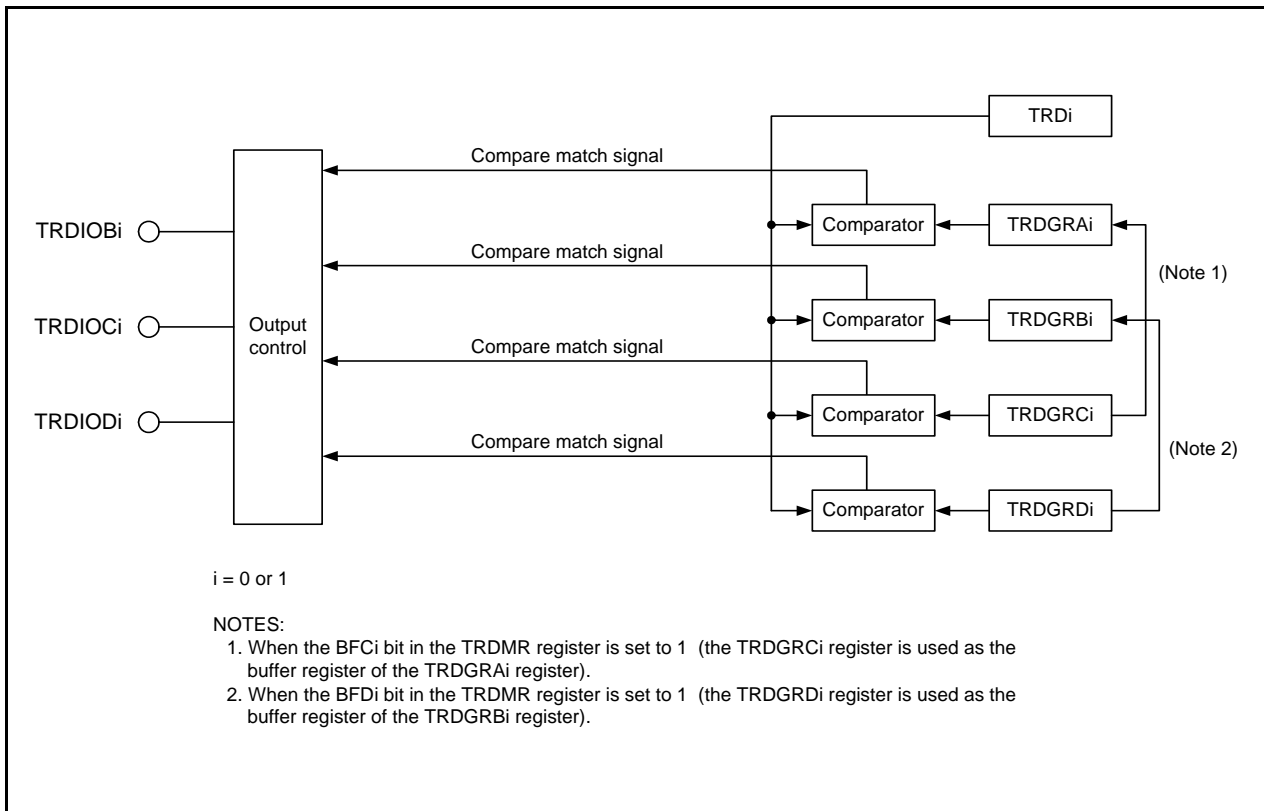
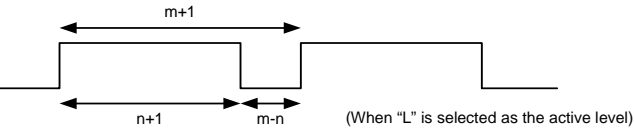

Figure 14.60 Block Diagram of PWM Mode

Table 14.27 PWM Mode Specifications

Item	Specification
Count sources	f1, f2, f4, f8, f32, fOCO40M External signal input to the TRDCLK pin (valid edge selected by a program)
Count operations	Increment
PWM waveform	<p>PWM period: $1/f_k \times (m+1)$ Active level width: $1/f_k \times (m-n)$ Inactive level width: $1/f_k \times (n+1)$ f_k: Frequency of count source m: Value set in the TRDGRA$_i$ ($i = 0$ or 1) register n: Value set in the TRDGR$_{ji}$ ($j = B, C, \text{ or } D$) register</p>  <p>(When "L" is selected as the active level)</p>
Count start condition	1 (count starts) is written to the TSTART $_i$ bit in the TRDSTR register.
Count stop conditions	<ul style="list-style-type: none"> • 0 (count stops) is written to the TSTART$_i$ bit in the TRDSTR register when the CSEL$_i$ bit in the TRDSTR register is set to 1. The PWM output pin holds output level before the count stops. • When the CSEL$_i$ bit in the TRDSTR register is set to 0, the count stops at the same time as the TRD$_i$ register is set to 0000h at the compare match in the TRDGRA$_i$ register. The PWM output pin holds level after output change by compare match.
Interrupt request generation timing	<ul style="list-style-type: none"> • Compare match (The content of the TRD$_i$ register matches content of the TRDGR$_{ji}$ register.) • TRD$_i$ register overflows
TRDIOA0 pin function	Programmable I/O port or TRDCLK (external clock) input
TRDIOA1 pin function	Programmable I/O port
TRDIOB0, TRDIOC0, TRDIOD0, TRDIOB1, TRDIOC1, TRDIOD1 pin functions	Programmable I/O port or pulse output (selectable by pin)
INT0 pin function	Programmable I/O port, pulse output forced cutoff signal input, or INT0 interrupt input
Read from timer	The count value can be read by reading the TRD $_i$ register.
Write to timer	The value can be written to the TRD $_i$ register.
Select functions	<ul style="list-style-type: none"> • 1 to 3 PWM output pins selected per 1 channel Either 1 pin or multiple pins of the TRDIOB$_i$, TRDIOC$_i$ or TRDIOD$_i$ pin. • The active level selected by pin. • Initial output level selected by pin. • Synchronous operation (Refer to 14.3.3 Synchronous Operation.) • Buffer operation (Refer to 14.3.2 Buffer Operation.) • Pulse output forced cutoff signal input (Refer to 14.3.4 Pulse Output Forced Cutoff.)

i = 0 or 1

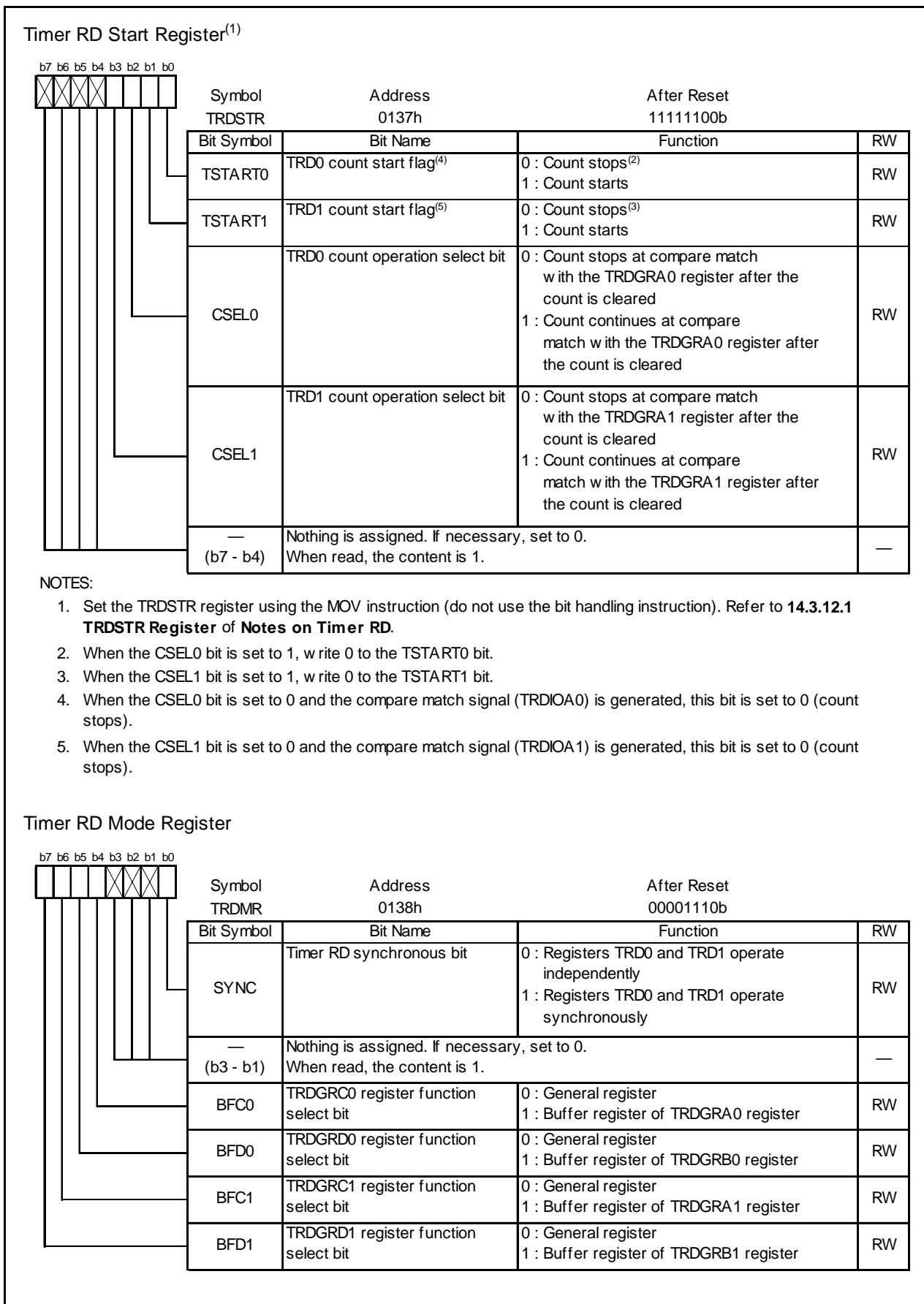

Figure 14.61 Registers TRDSTR and TRDMR in PWM Mode

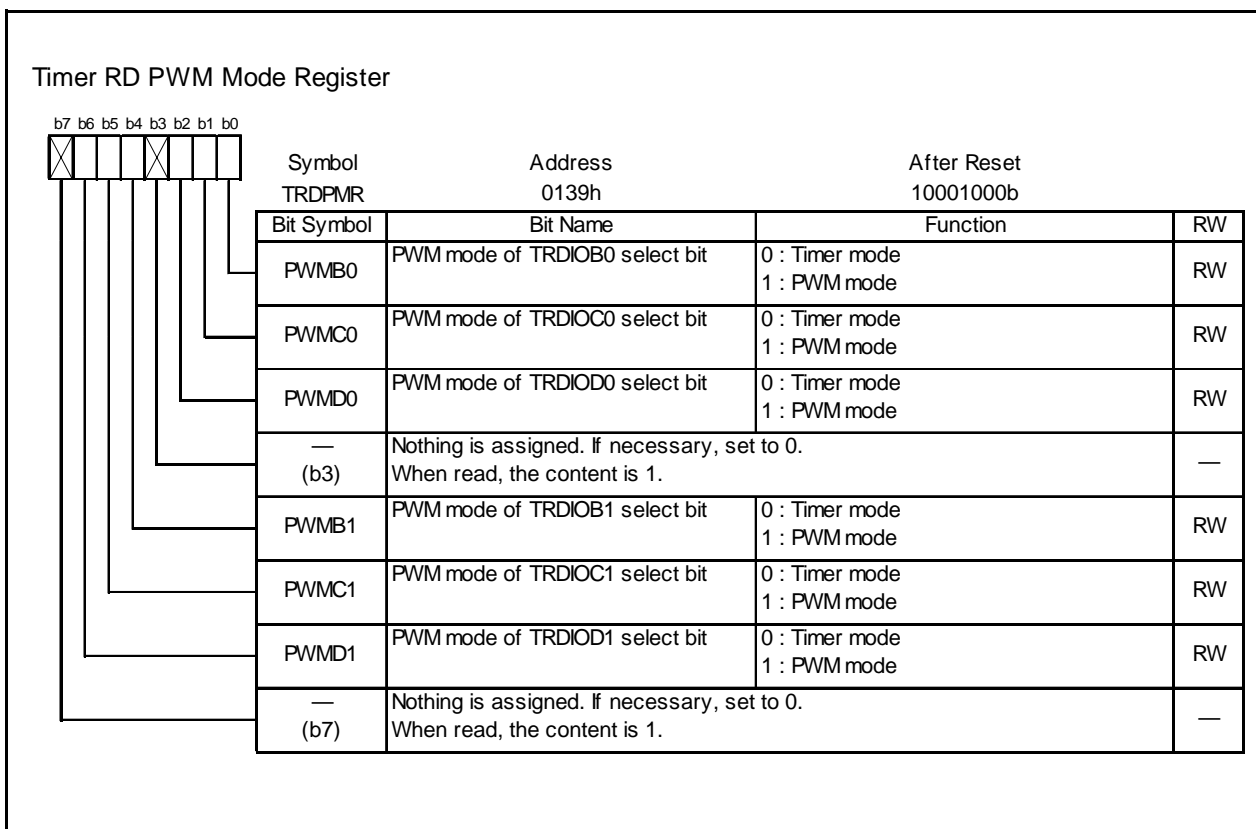

Figure 14.62 TRDPMR Register in PWM Mode

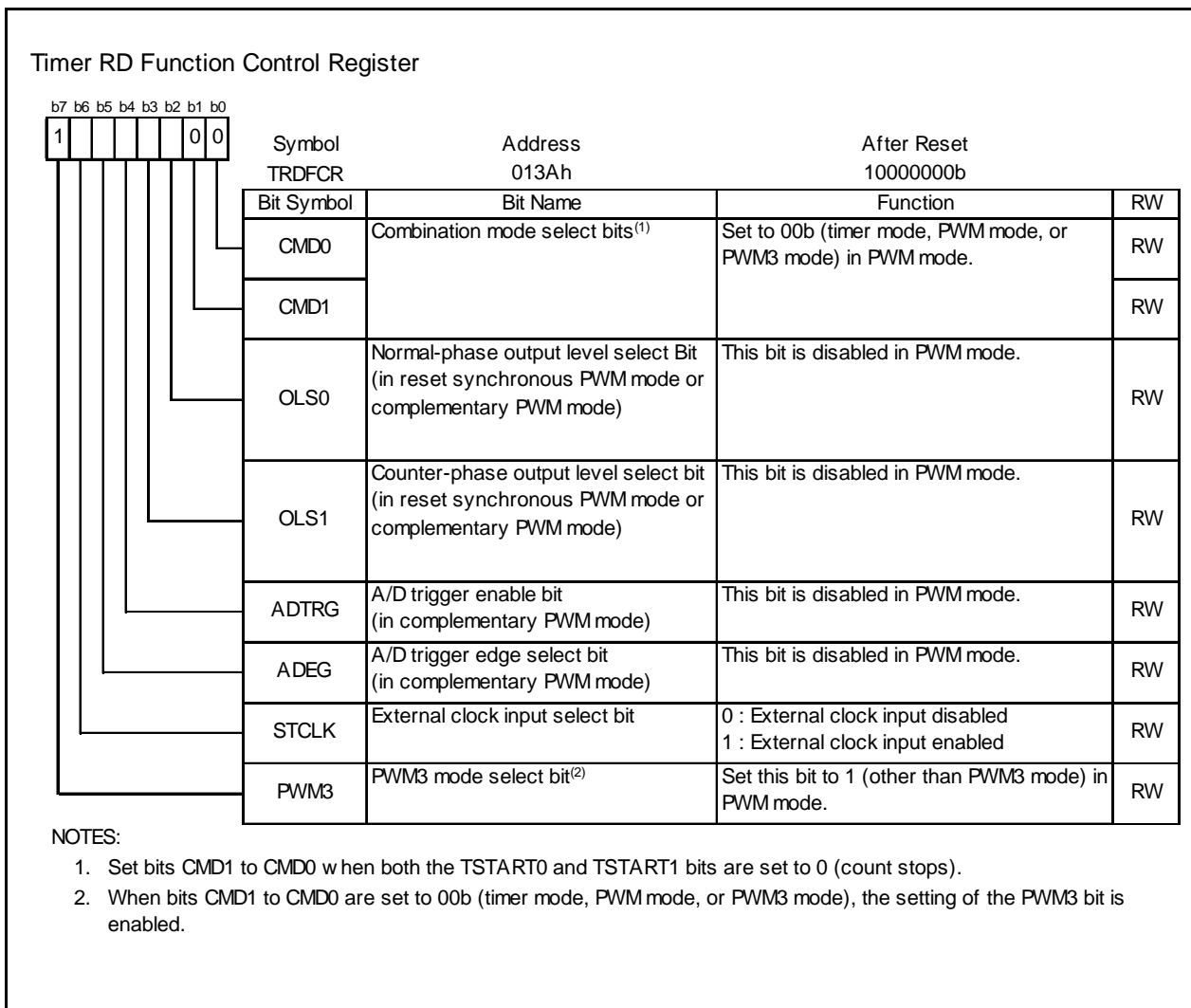

Figure 14.63 TRDFCR Register in PWM Mode

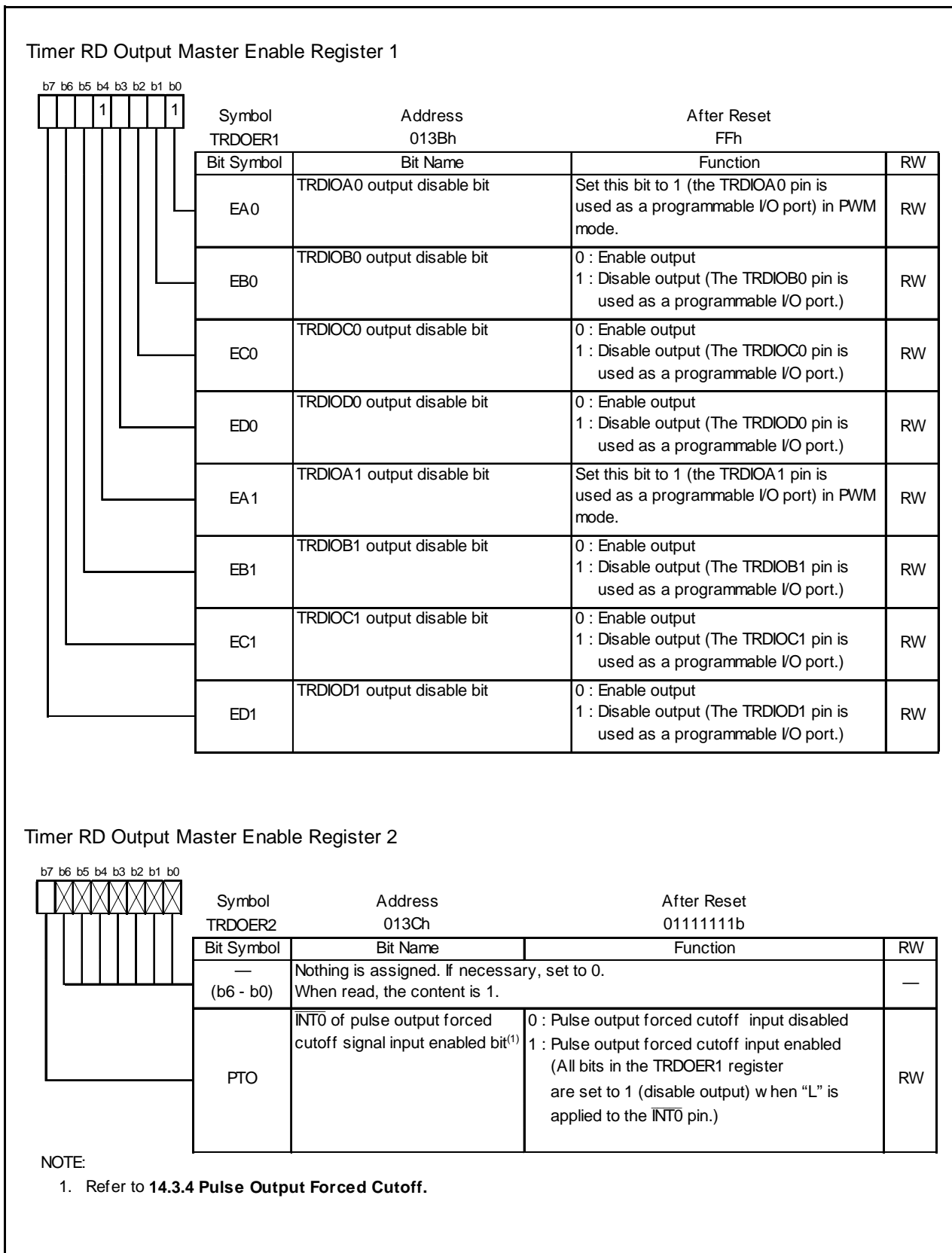

Figure 14.64 Registers TRDOER1 to TRDOER2 in PWM Mode

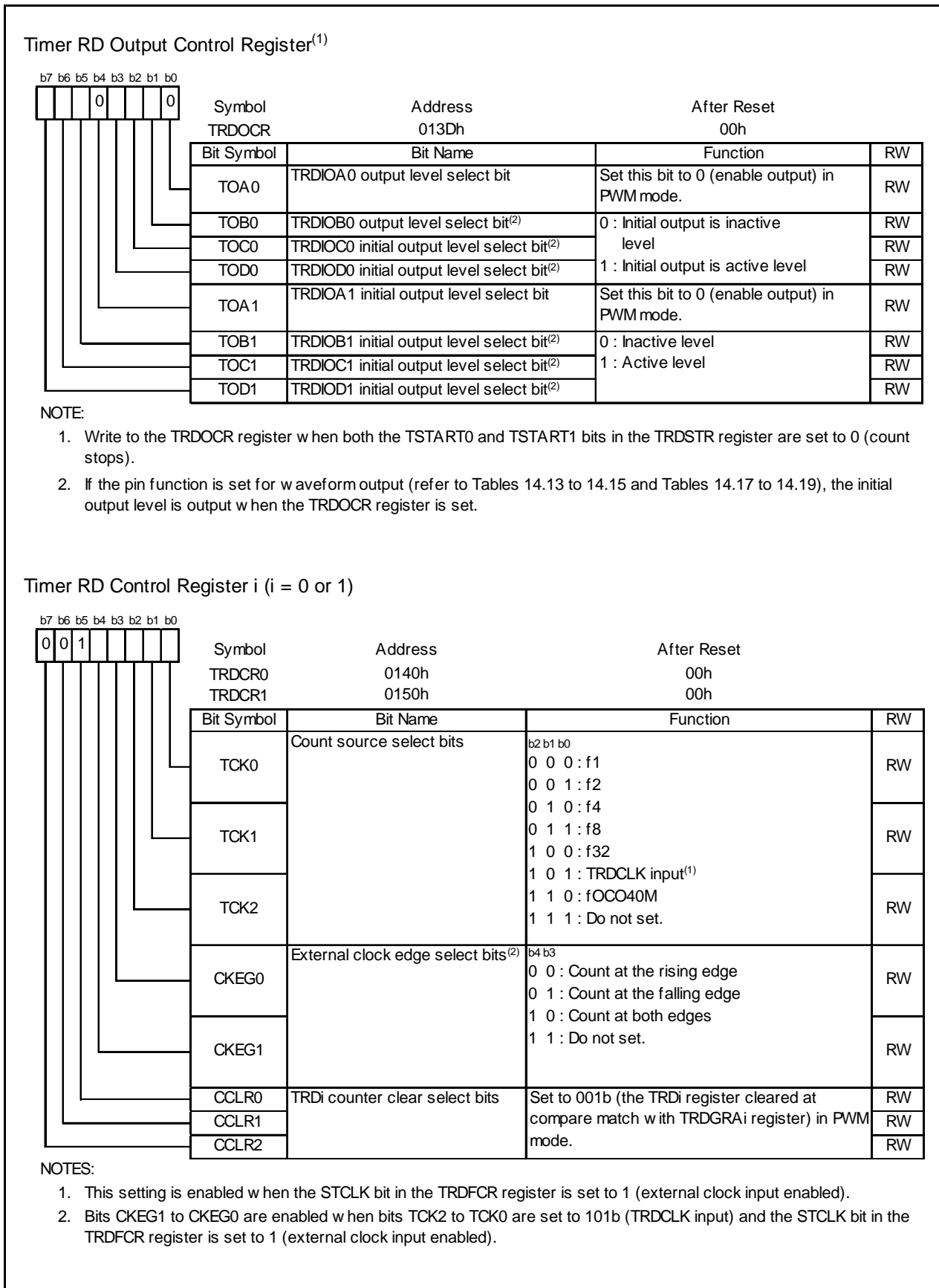

Figure 14.65 Registers TRDOCR and TRDCR0 to TRDCR1 in PWM Mode

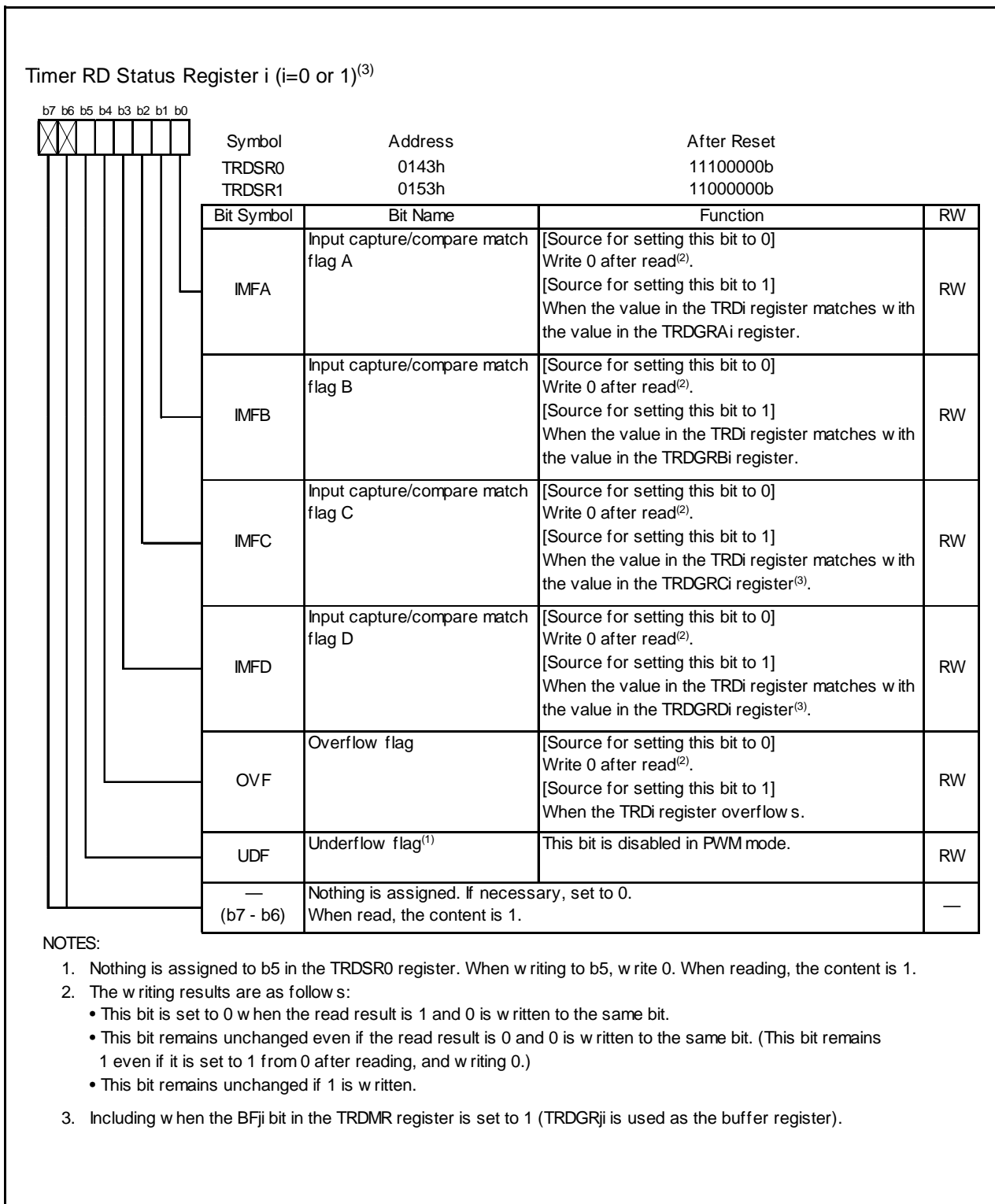

Figure 14.66 Registers TRDSR0 to TRDSR1 in PWM Mode

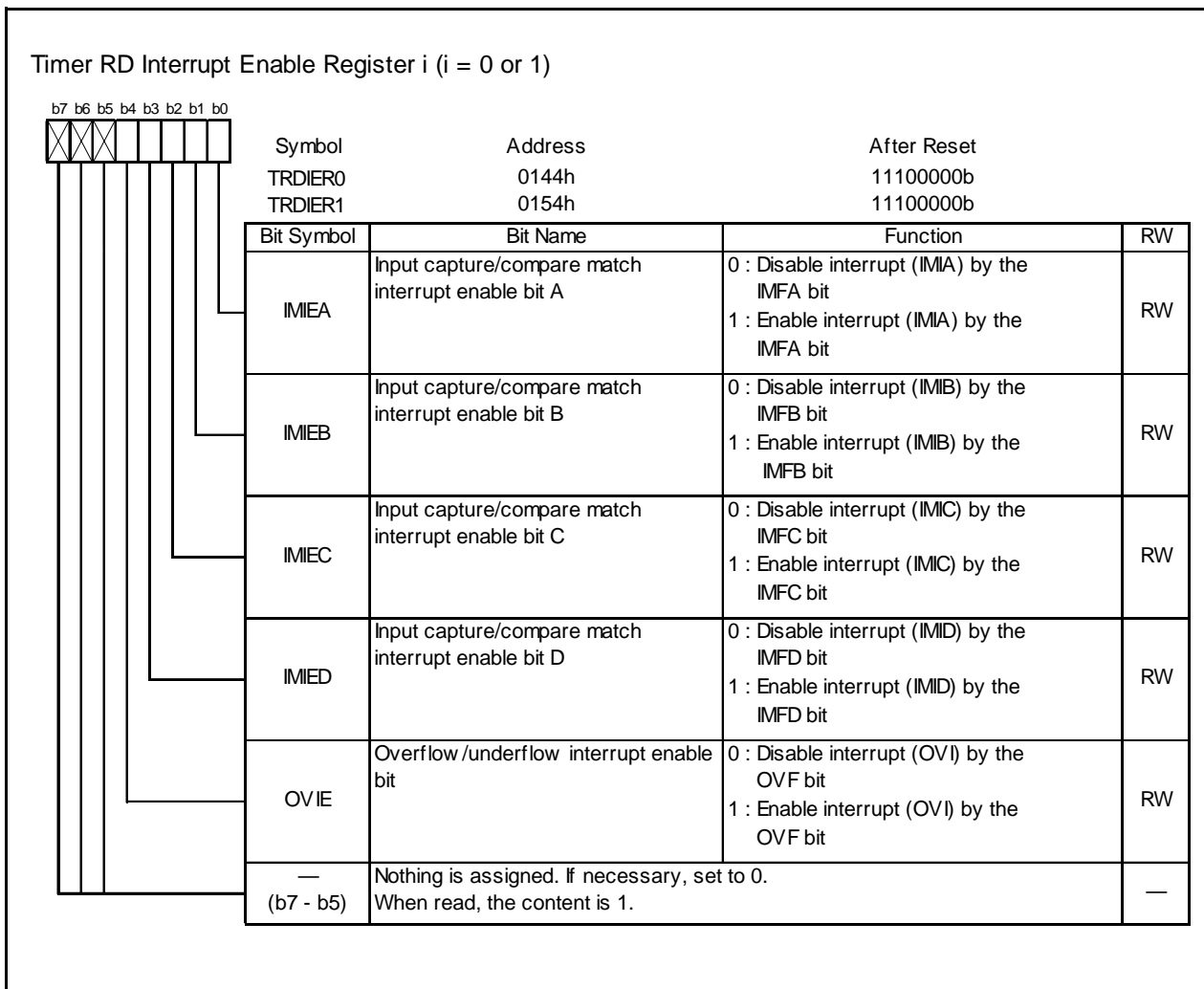

Figure 14.67 Registers TRDIER0 to TRDIER1 in PWM Mode

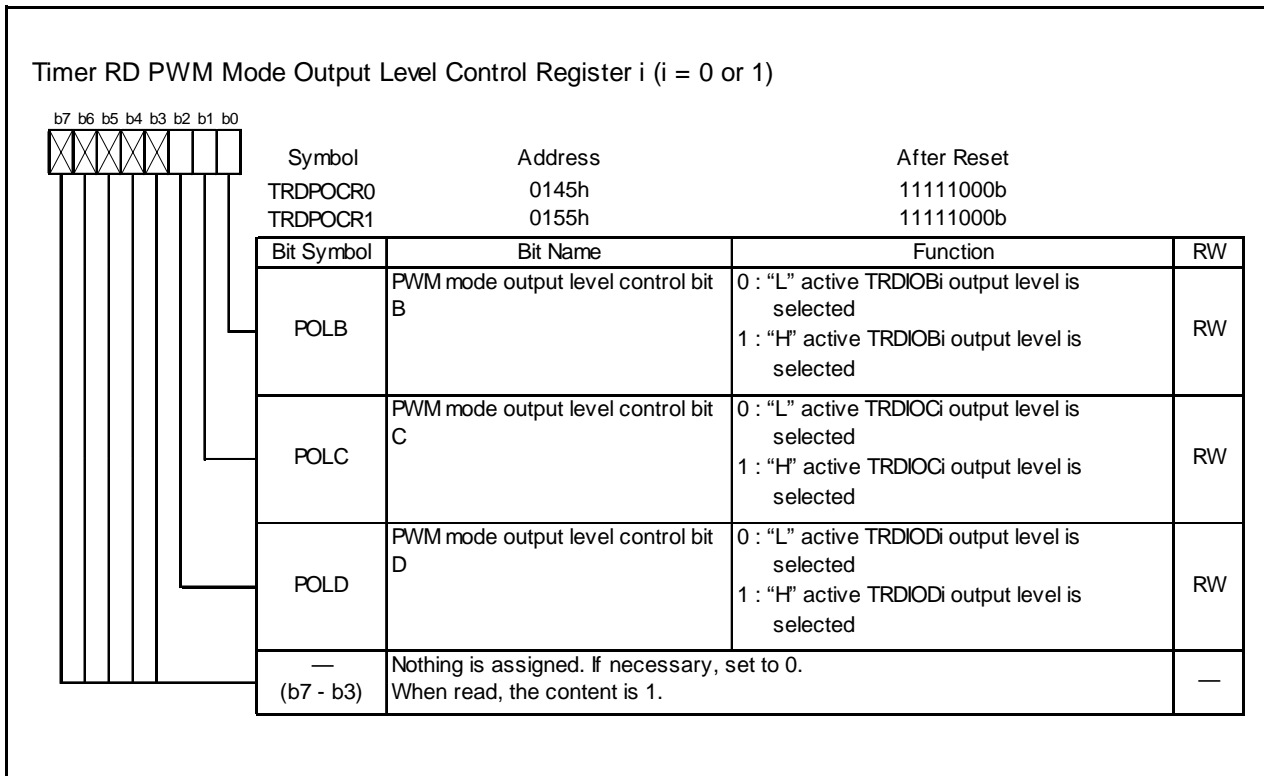

Figure 14.68 Registers TRDPOCR0 to TRDPOCR1 in PWM Mode

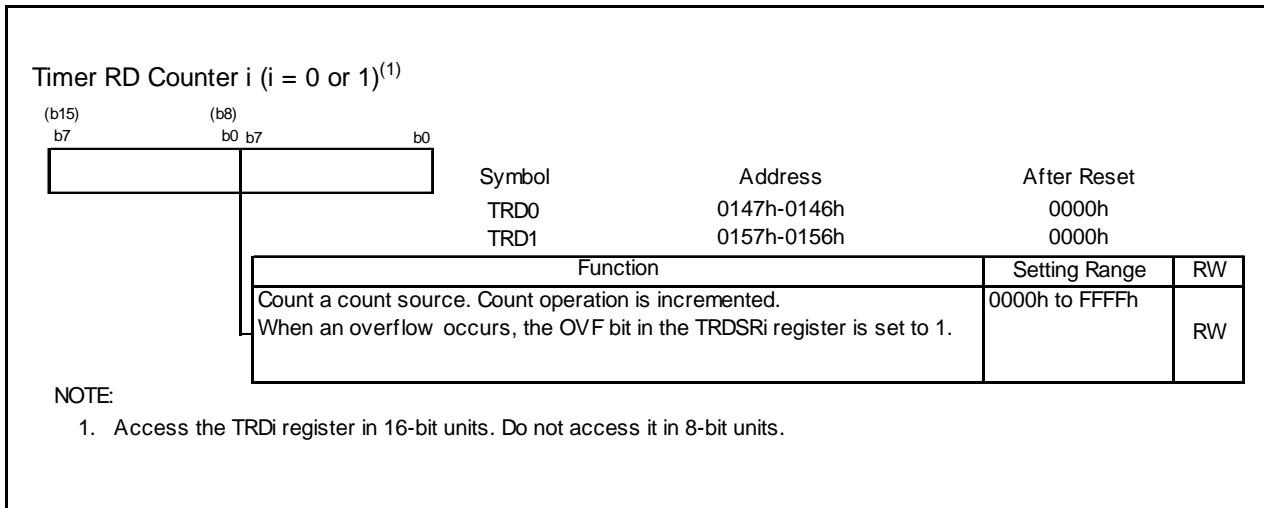

Figure 14.69 Registers TRD0 to TRD1 in PWM Mode

Timer RD General Registers Ai, Bi, Ci, and Di (i = 0 or 1) ⁽¹⁾		Symbol	Address	After Reset
(b15) b7	(b8) b0			
		TRDGRA0	0149h-0148h	FFFFh
		TRDGRB0	014Bh-014Ah	FFFFh
		TRDGRC0	014Dh-014Ch	FFFFh
		TRDGRD0	014Fh-014Eh	FFFFh
		TRDGRA1	0159h-0158h	FFFFh
		TRDGRB1	015Bh-015Ah	FFFFh
		TRDGRC1	015Dh-015Ch	FFFFh
		TRDGRD1	015Fh-015Eh	FFFFh
Function				RW
Refer to Table 14.28 TRDGRji Register Functions in PWM Mode.				RW

NOTE:

- Access registers TRDGRAi to TRDGRDi in 16-bit units. Do not access them in 8-bit units.

Figure 14.70 Registers TRDGRAi, TRDGRBi, TRDGRCi, and TRDGRDi in PWM Mode

The following registers are disabled in the PWM mode: TRDDF0, TRDDF1, TRDIORA0, TRDIORC0, TRDIORA1, and TRDIORC1.

Table 14.28 TRDGRji Register Functions in PWM Mode

Register	Setting	Register Function	PWM Output Pin
TRDGRAi	–	General register. Set the PWM period	–
TRDGRBi	–	General register. Set the changing point of PWM output	TRDIOBi
TRDGRCi	BFCi = 0	General register. Set the changing point of PWM output	TRDIOCi
TRDGRDi	BFDi = 0		TRDIODi
TRDGRCi	BFCi = 1	Buffer register. Set the next PWM period (Refer to 14.3.2 Buffer Operation.)	–
TRDGRDi	BFDi = 1	Buffer register. Set the changing point of the next PWM output (Refer to 14.3.2 Buffer Operation.)	TRDIOBi

i = 0 or 1

BFCi, BFDi: Bits in TRDMR register

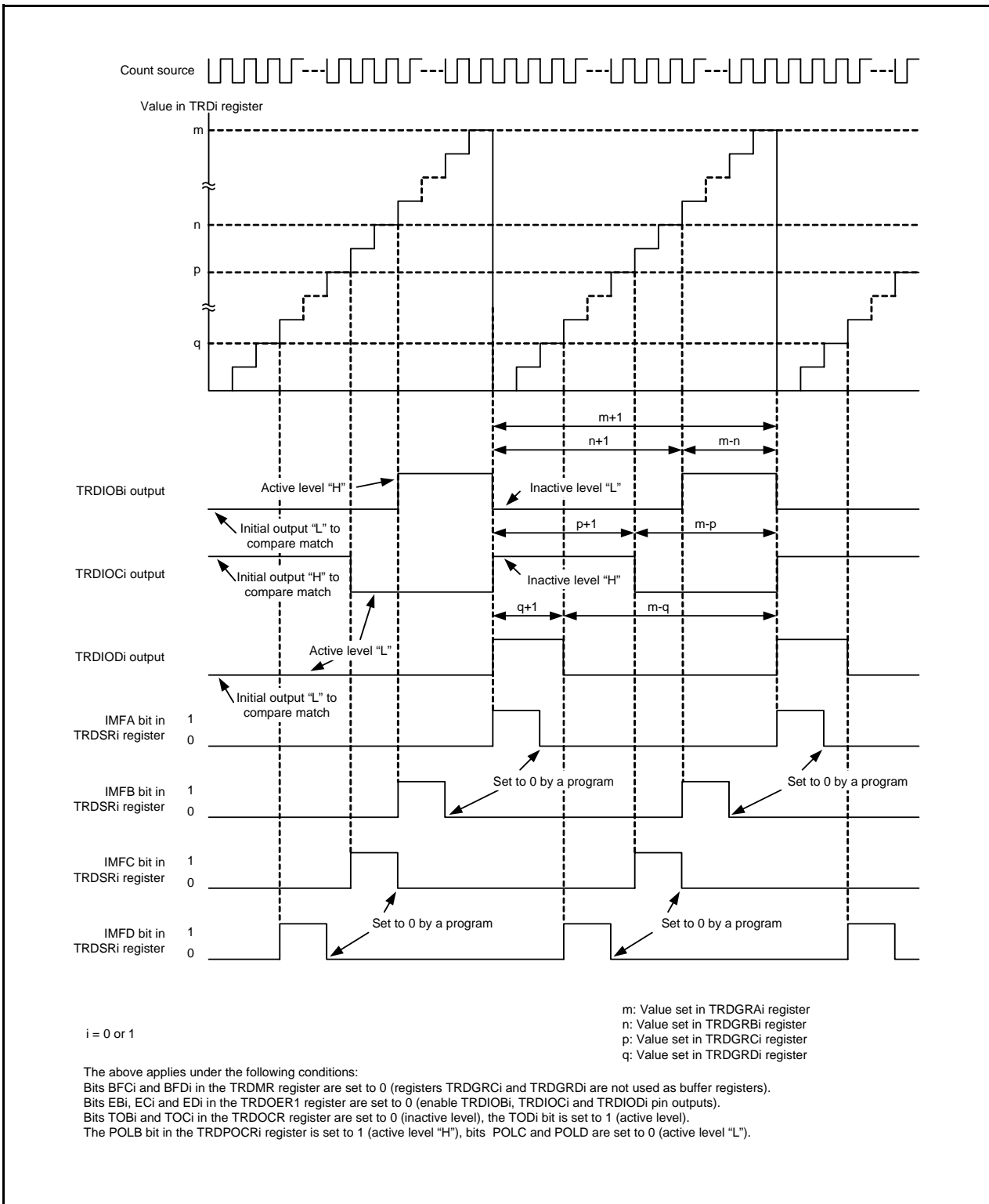

Figure 14.71 Operating Example of PWM Mode

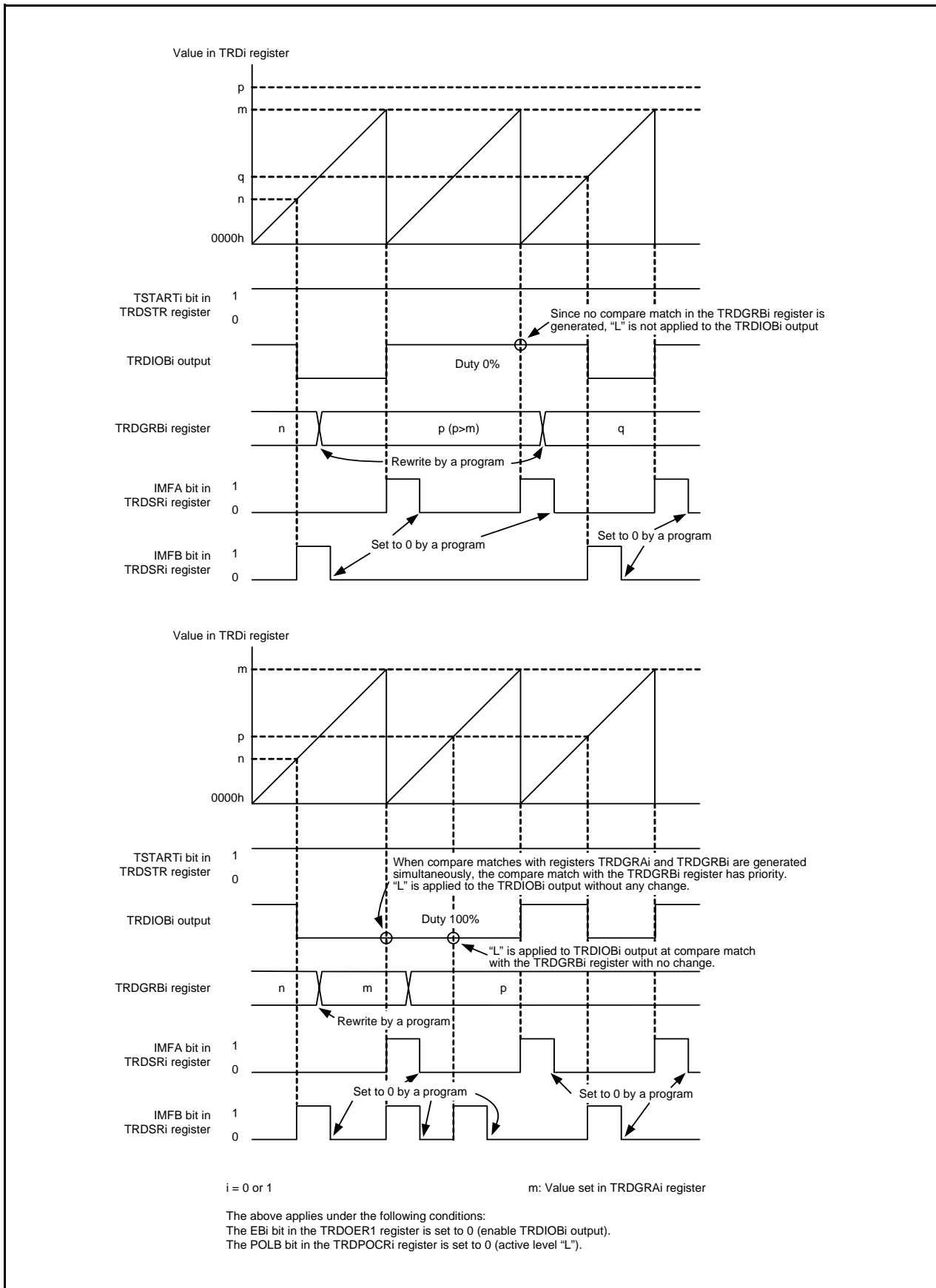

Figure 14.72 Operating Example of PWM Mode (Duty 0%, Duty 100%)

14.3.8 Reset Synchronous PWM Mode

In this mode, 3 normal-phases and 3 counter-phases of the PWM waveform are output with the same period (three-phase, sawtooth wave modulation, and no dead time).

Figure 14.73 shows a Block Diagram of Reset Synchronous PWM Mode, and Table 14.29 lists the Reset Synchronous PWM Mode Specifications. Figures 14.74 to 14.81 show the Registers Associated with Reset Synchronous PWM Mode and Figure 14.82 shows an Operating Example of Reset Synchronous PWM Mode. Refer to **Figure 14.71 Operating Example of PWM Mode** for an operating example of PWM Mode with duty 0% and duty 100%.

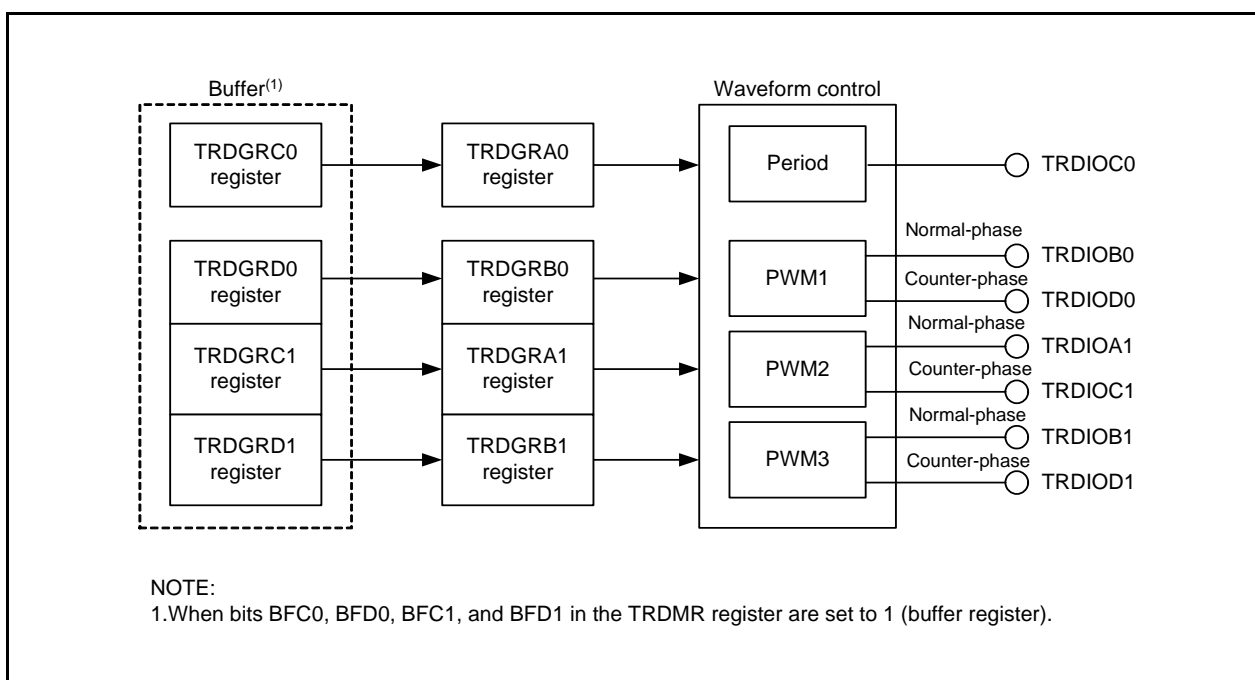

Figure 14.73 Block Diagram of Reset Synchronous PWM Mode

Table 14.29 Reset Synchronous PWM Mode Specifications

Item	Specification
Count sources	f1, f2, f4, f8, f32, fOCO40M External signal input to the TRDCLK pin (valid edge selected by a program)
Count operations	The TRD0 register is incremented (the TRD1 register is not used).
PWM waveform	<p>PWM period : $1/f_k \times (m+1)$ Active level width of normal-phase : $1/f_k \times (m-n)$ Active level width of counter-phase: $1/f_k \times (n+1)$ f_k: Frequency of count source m: Value set in the TRDGRA0 register n: Value set in the TRDGRB0 register (PWM1 output), Value set in the TRDGRA1 register (PWM2 output), Value set in the TRDGRB1 register (PWM3 output)</p> <p style="text-align: center;">(When "L" is selected as the active level)</p>
Count start condition	1 (count starts) is written to the TSTART0 bit in the TRDSTR register.
Count stop conditions	<ul style="list-style-type: none"> • 0 (count stops) is written to the TSTART0 bit in the TRDSTR register when the CSEL0 bit in the TRDSTR register is set to 1. The PWM output pin holds output level before the count stops • When the CSEL0 bit in the TRDSTR register is set to 0, the count stops at the same time as the TRD0 register is set to 0000h at the compare match in the TRDGRA0 register. The PWM output pin holds level after output change at compare match.
Interrupt request generation timing	<ul style="list-style-type: none"> • Compare match (the content of the TRD0 register matches content of registers TRDGRj0, TRDGRA1, and TRDGRB1). • The TRD0 register overflows
TRDIOA0 pin function	Programmable I/O port or TRDCLK (external clock) input
TRDIOB0 pin function	PWM1 output normal-phase output
TRDIOD0 pin function	PWM1 output counter-phase output
TRDIOA1 pin function	PWM2 output normal-phase output
TRDIOC1 pin function	PWM2 output counter-phase output
TRDIOB1 pin function	PWM3 output normal-phase output
TRDIOD1 pin function	PWM3 output counter-phase output
TRDIOC0 pin function	Output inverted every PWM period
INT0 pin function	Programmable I/O port, pulse output forced cutoff signal input, or INT0 interrupt input
Read from timer	The count value can be read by reading the TRD0 register.
Write to timer	The value can be written to the TRD0 register.
Select functions	<ul style="list-style-type: none"> • The active level of normal-phase and counter-phase and initial output level selected individually. • Buffer operation (Refer to 14.3.2 Buffer Operation.) • Pulse output forced cutoff signal input (Refer to 14.3.4 Pulse Output Forced Cutoff.)

j = either A, B, C, or D

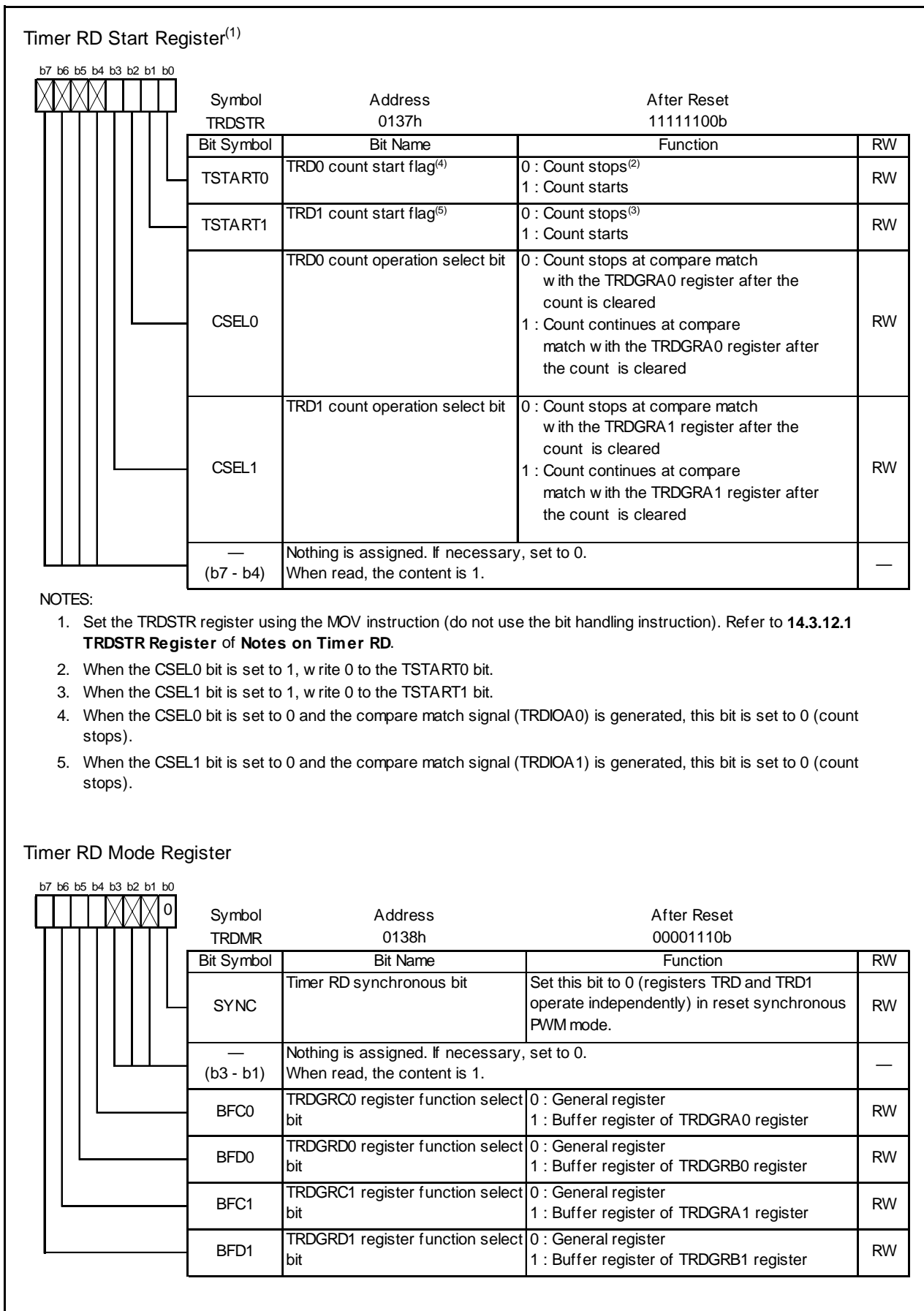

Figure 14.74 Registers TRDSTR and TRDMR in Reset Synchronous PWM Mode

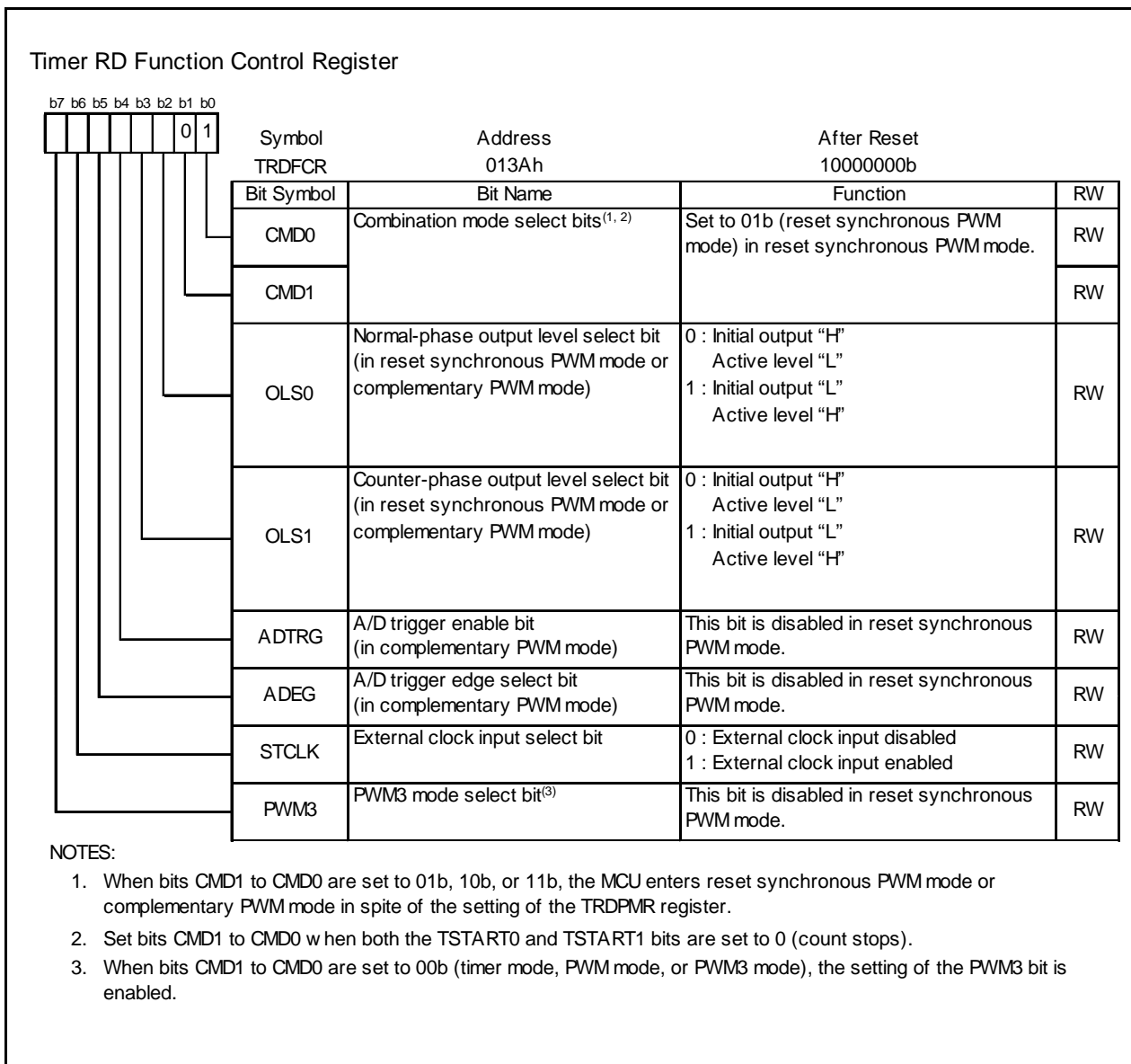

Figure 14.75 TRDFCR Register in Reset Synchronous PWM Mode

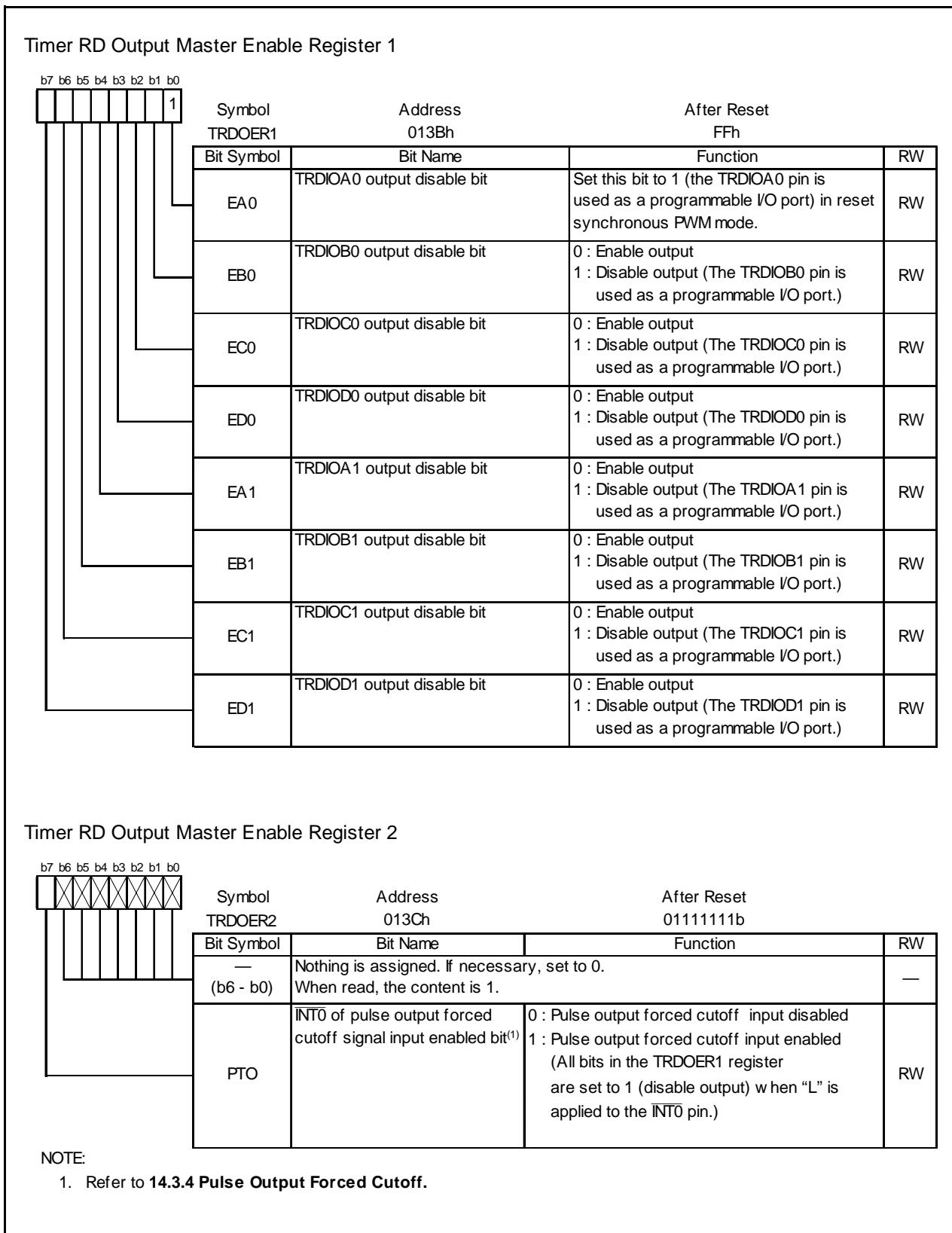

Figure 14.76 Registers TRDOER1 to TRDOER2 in Reset Synchronous PWM Mode

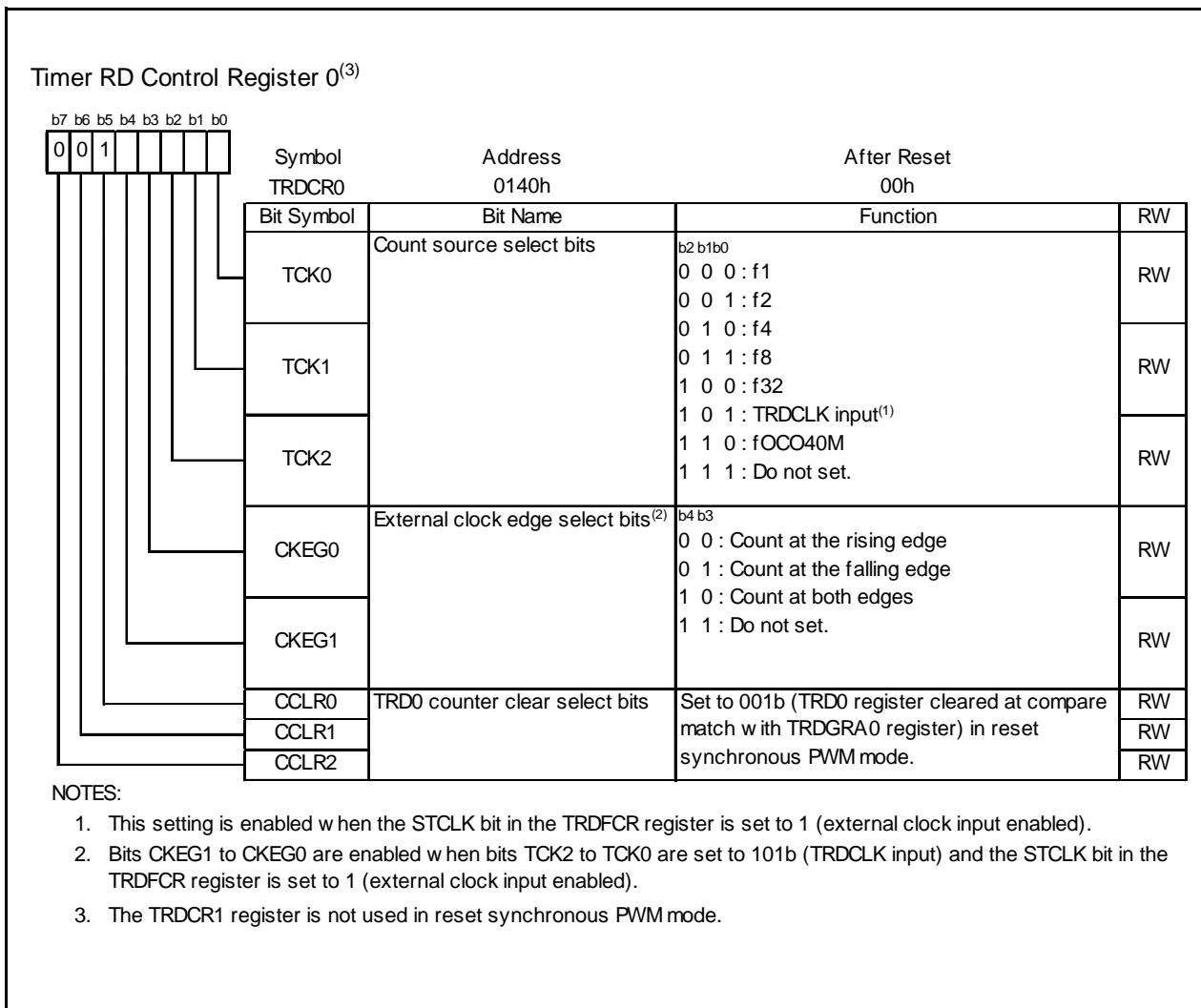

Figure 14.77 TRDCR0 Register in Reset Synchronous PWM Mode

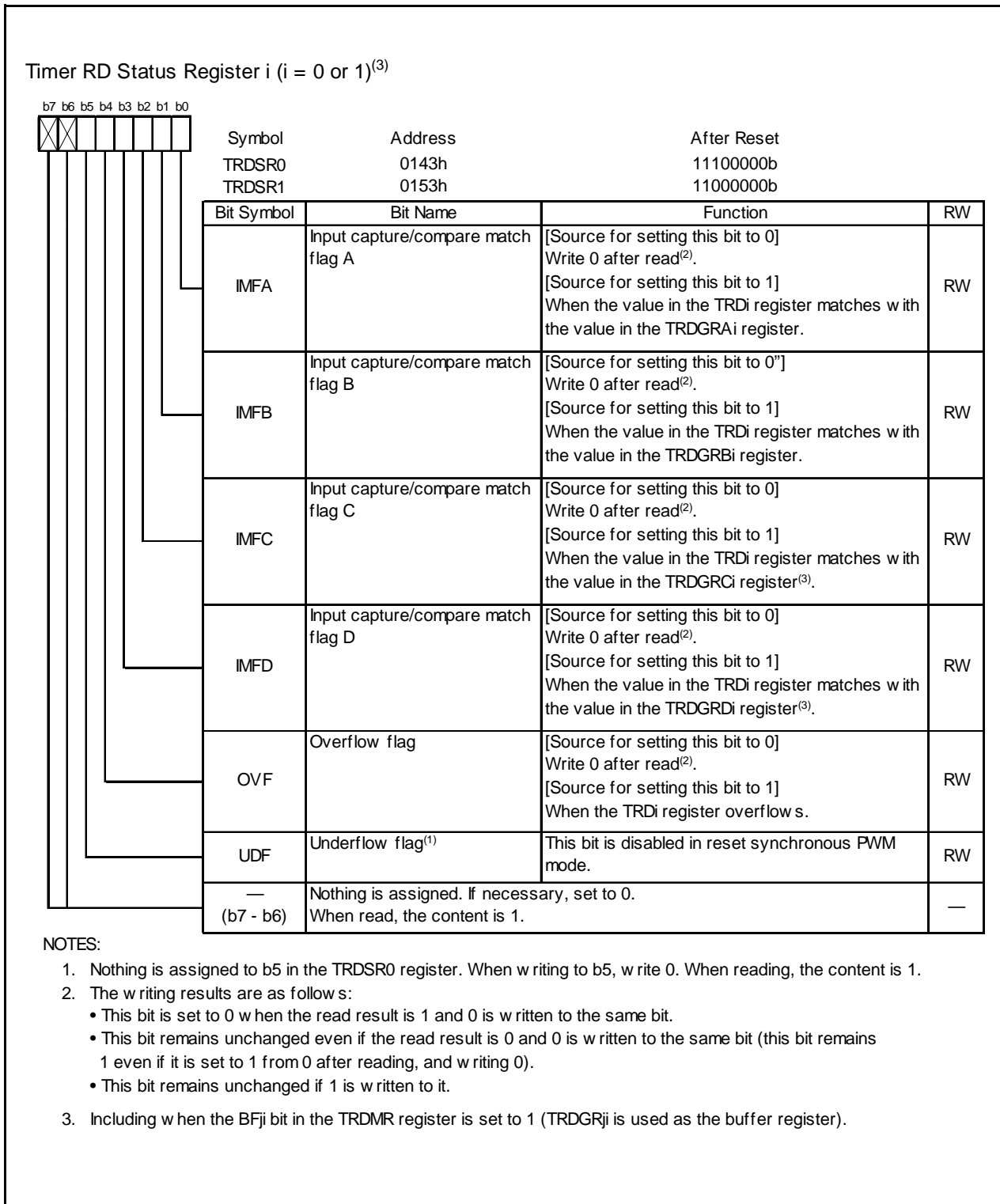

Figure 14.78 Registers TRDSR0 to TRDSR1 in Reset Synchronous PWM Mode

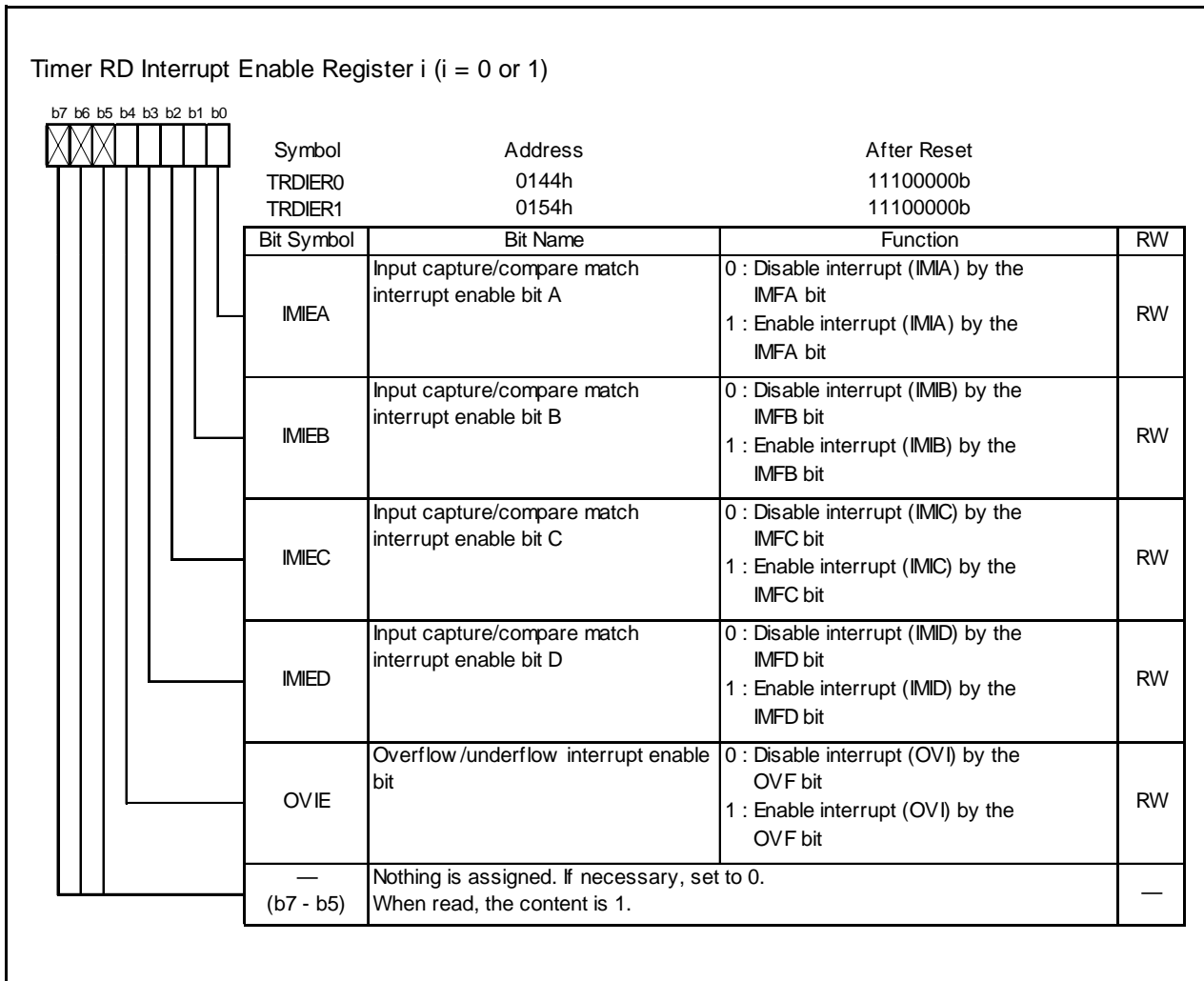

Figure 14.79 Registers TRDIER0 to TRDIER1 in Reset Synchronous PWM Mode

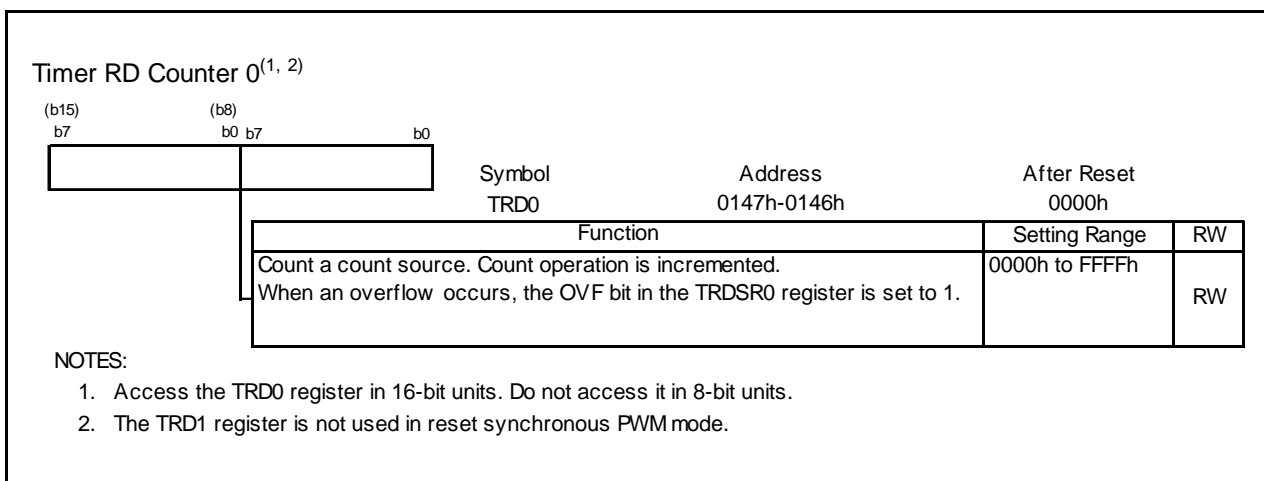

Figure 14.80 TRD0 Registrar in Reset Synchronous PWM Mode

Timer RD General Registers Ai, Bi, Ci, and Di (i = 0 or 1)⁽¹⁾

(b15) b7		(b8) b0 b7		b0	Symbol	Address	After Reset
					TRDGRA0	0149h-0148h	FFFFh
					TRDGRB0	014Bh-014Ah	FFFFh
					TRDGRC0	014Dh-014Ch	FFFFh
					TRDGRD0	014Fh-014Eh	FFFFh
					TRDGRA1	0159h-0158h	FFFFh
					TRDGRB1	015Bh-015Ah	FFFFh
					TRDGRC1	015Dh-015Ch	FFFFh
					TRDGRD1	015Fh-015Eh	FFFFh
					Function		
Refer to Table 14.30 TRDGRji Register Function in Reset Synchronous PWM Mode.							RW

NOTE:
1. Access registers TRDGRAi to TRDGRBi in 16-bit units. Do not access them in 8-bit units.

Figure 14.81 Registers TRDGRAi, TRDGRBi, TRDGRCi, and TRDGRDi in Reset Synchronous PWM Mode

The following registers are disabled in the reset synchronous PWM mode: TRDPMR, TRDOCR, TRDDF0, TRDDF1, TRDIOA0, TRDIORC0, TRDPOCR0, TRDIOA1, TRDIORC1, and TRDPOCR1.

Table 14.30 TRDGRji Register Functions in Reset Synchronous PWM Mode

Register	Setting	Register Function	PWM Output Pin
TRDGRA0	–	General register. Set the PWM period.	(Output inverted every PWM period and TRDIOC0 pin)
TRDGRB0	–	General register. Set the changing point of PWM1 output.	TRDIOB0 TRDIOD0
TRDGRC0	BFC0 = 0	(These registers are not used in reset synchronous PWM mode.)	–
TRDGRD0	BFD0 = 0		
TRDGRA1	–	General register. Set the changing point of PWM2 output.	TRDIOA1 TRDIOC1
TRDGRB1	–	General register. Set the changing point of PWM3 output.	TRDIOB1 TRDIOD1
TRDGRC1	BFC1 = 0	(These points are not used in reset synchronous PWM mode.)	–
TRDGRD1	BFD1 = 0		
TRDGRC0	BFC0 = 1	Buffer register. Set the next PWM period. (Refer to 14.3.2 Buffer Operation.)	(Output inverted every PWM period and TRDIOC0 pin)
TRDGRD0	BFD0 = 1	Buffer register. Set the changing point of the next PWM1 output. (Refer to 14.3.2 Buffer Operation.)	TRDIOB0 TRDIOD0
TRDGRC1	BFC1 = 1	Buffer register. Set the changing point of the next PWM2 output. (Refer to 14.3.2 Buffer Operation.)	TRDIOA1 TRDIOC1
TRDGRD1	BFD1 = 1	Buffer register. Set the changing point of the next PWM3 output. (Refer to 14.3.2 Buffer Operation.)	TRDIOB1 TRDIOD1

BFC0, BFD0, BFC1, BFD1: Bits in TRDMR register

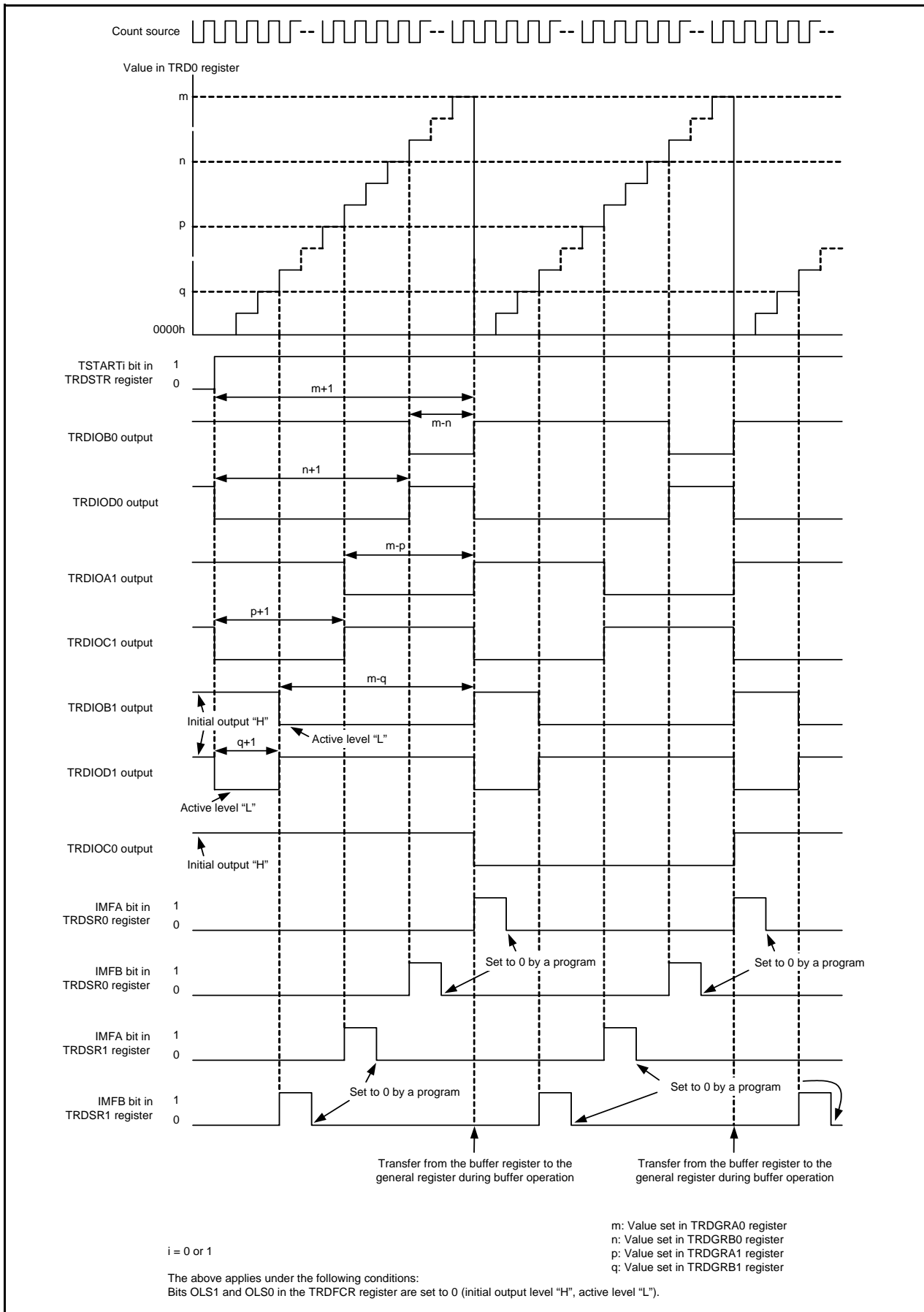

Figure 14.82 Operating Example of Reset Synchronous PWM Mode

14.3.9 Complementary PWM Mode

In this mode, 3 normal-phases and 3 counter-phases of the PWM waveform are output with the same period (three-phase, triangular wave modulation, and with dead time).

Figure 14.83 shows a Block Diagram of Complementary PWM Mode, and Table 14.31 lists the Complementary PWM Mode Specifications. Figures 14.84 to 14.92 show the Registers Associated with Complementary PWM Mode, and Figure 14.94 shows Operating Example of Complementary PWM Mode.

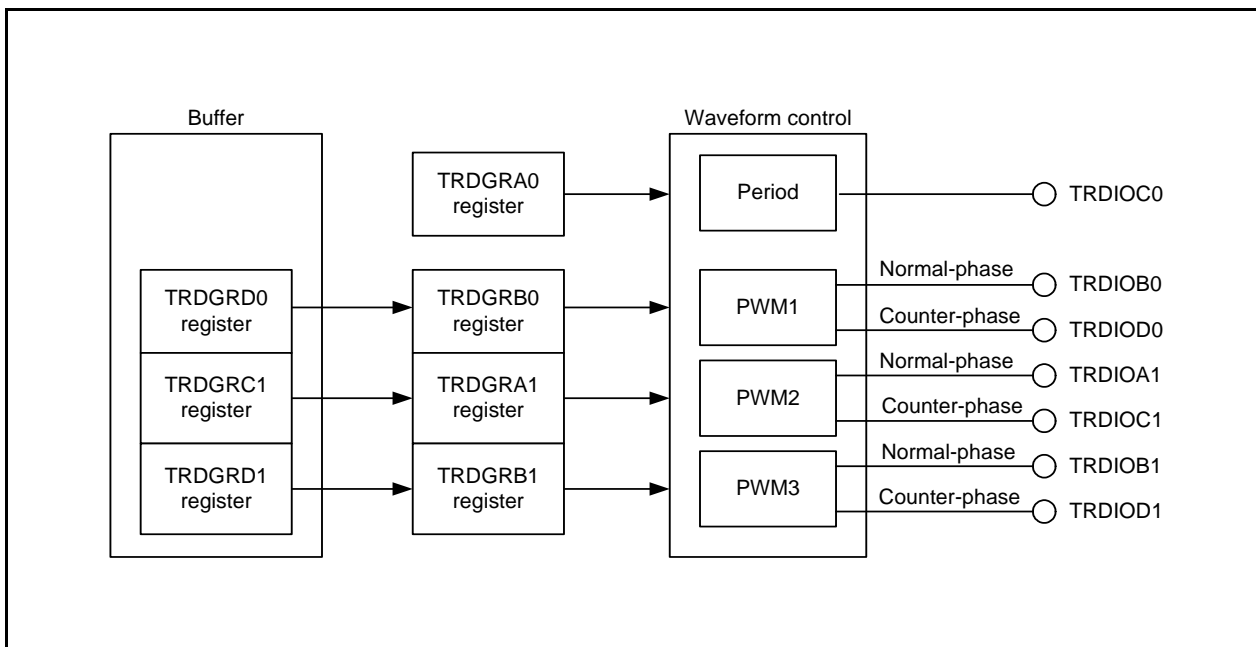
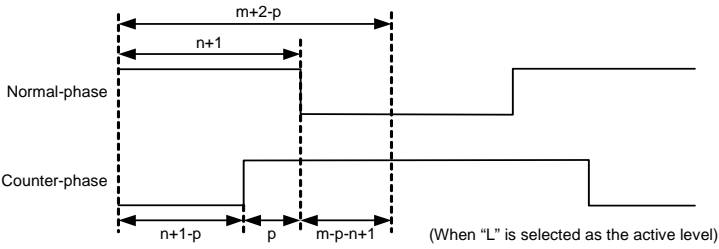

Figure 14.83 Block Diagram of Complementary PWM Mode

Table 14.31 Complementary PWM Mode Specifications

Item	Specification
Count sources	f1, f2, f4, f8, f32, fOCO40M External signal input to the TRDCLK pin (valid edge selected by a program) Set bits TCK2 to TCK0 in the TRDCR1 register to the same value (same count source) as bits TCK2 to TCK0 in the TRDCR0 register.
Count operations	Increment or decrement Registers TRD0 and TRD1 are decremented with the compare match in registers TRD0 and TRDGRA0 during increment operation. The TRD1 register value is changed from 0000h to FFFFh during decrement operation, and registers TRD0 and TRD1 are incremented.
PWM operations	PWM period: $1/fk \times (m+2-p) \times 2^{(1)}$ Dead time: p Active level width of normal-phase: $1/fk \times (m-n-p+1) \times 2$ Active level width of counter-phase: $1/fk \times (n+1-p) \times 2$ fk: Frequency of count source m: Value set in the TRDGRA0 register n: Value set in the TRDGRB0 register (PWM1 output) Value set in the TRDGRA1 register (PWM2 output) Value set in the TRDGRB1 register (PWM3 output) p: Value set in the TRD0 register  (When "L" is selected as the active level)
Count start condition	1 (count starts) is written to bits TSTART0 and TSTART1 in the TRDSTR register.
Count stop conditions	0 (count stops) is written to bits TSTART0 and TSTART1 in the TRDSTR register when the CSEL0 bit in the TRDSTR register is set to 1. (The PWM output pin holds output level before the count stops.)
Interrupt request generation timing	<ul style="list-style-type: none"> Compare match (The content of the TRDi register matches content of the TRDGRji register.) The TRD1 register undeflows
TRDIOA0 pin function	Programmable I/O port or TRDCLK (external clock) input
TRDIOB0 pin function	PWM1 output normal-phase output
TRDIOD0 pin function	PWM1 output counter-phase output
TRDIOA1 pin function	PWM2 output normal-phase output
TRDIOC1 pin function	PWM2 output counter-phase output
TRDIOB1 pin function	PWM3 output normal-phase output
TRDIOD1 pin function	PWM3 output counter-phase output
TRDIOC0 pin function	Output inverted every 1/2 period of PWM
INT0 pin function	Programmable I/O port, pulse output forced cutoff signal input or INT0 interrupt input
Read from timer	The count value can be read by reading the TRDi register.
Write to timer	The value can be written to the TRDi register.
Select functions	<ul style="list-style-type: none"> Pulse output forced cutoff signal input (Refer to 14.3.4 Pulse Output Forced Cutoff.) The active level of normal-phase and counter-phase and initial output level selected individually Transfer timing from the buffer register selected A/D trigger generated

i = 0 or 1, j = either A, B, C, or D

NOTE:

- After a count starts, the PWM period is fixed.

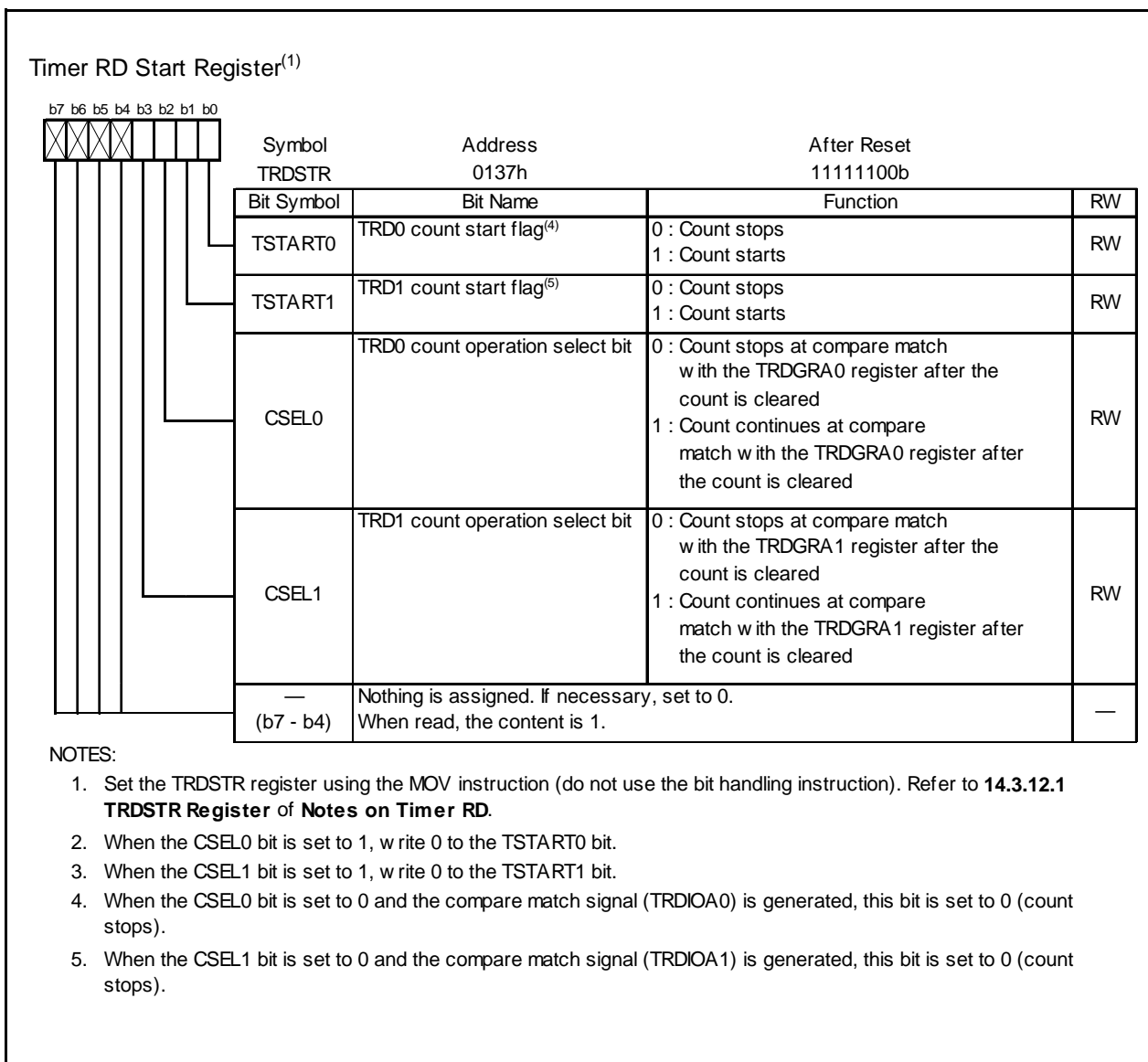

Figure 14.84 TRDSTR Register in Complementary PWM Mode

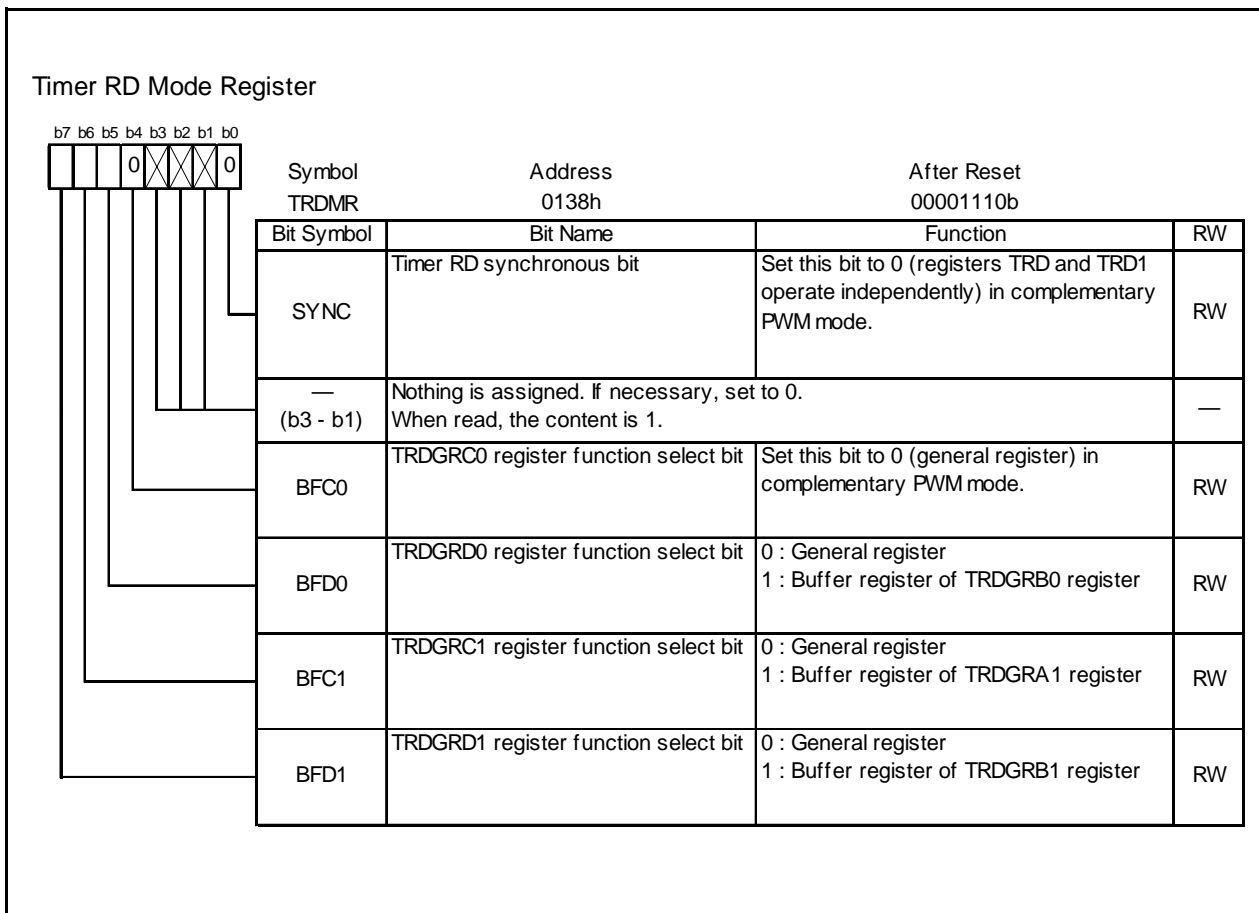

Figure 14.85 TRDMR Register in Complementary PWM Mode

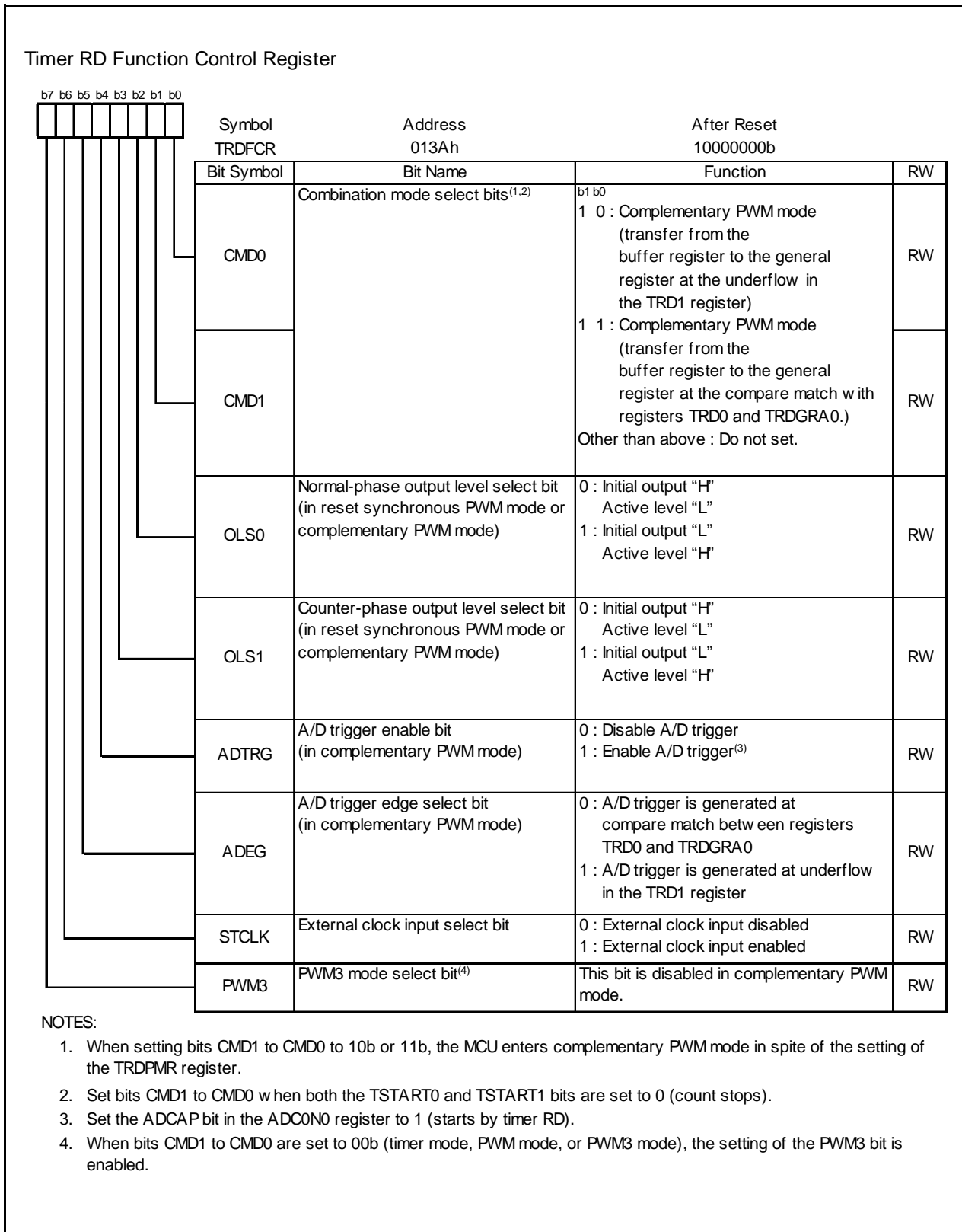

Figure 14.86 TRDFCR Register in Complementary PWM Mode

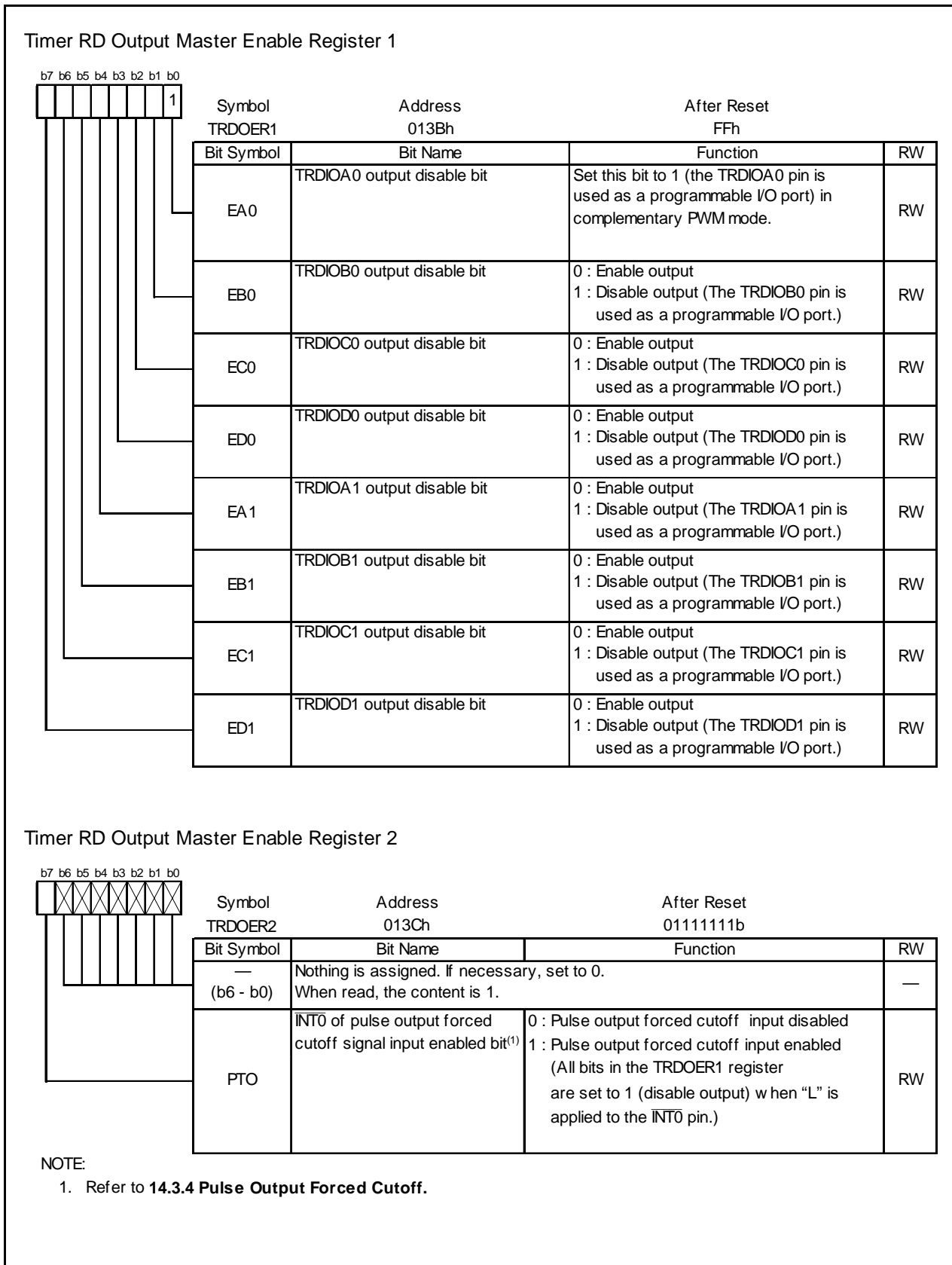

Figure 14.87 Registers TRDOER1 to TRDOER2 in Complementary PWM Mode

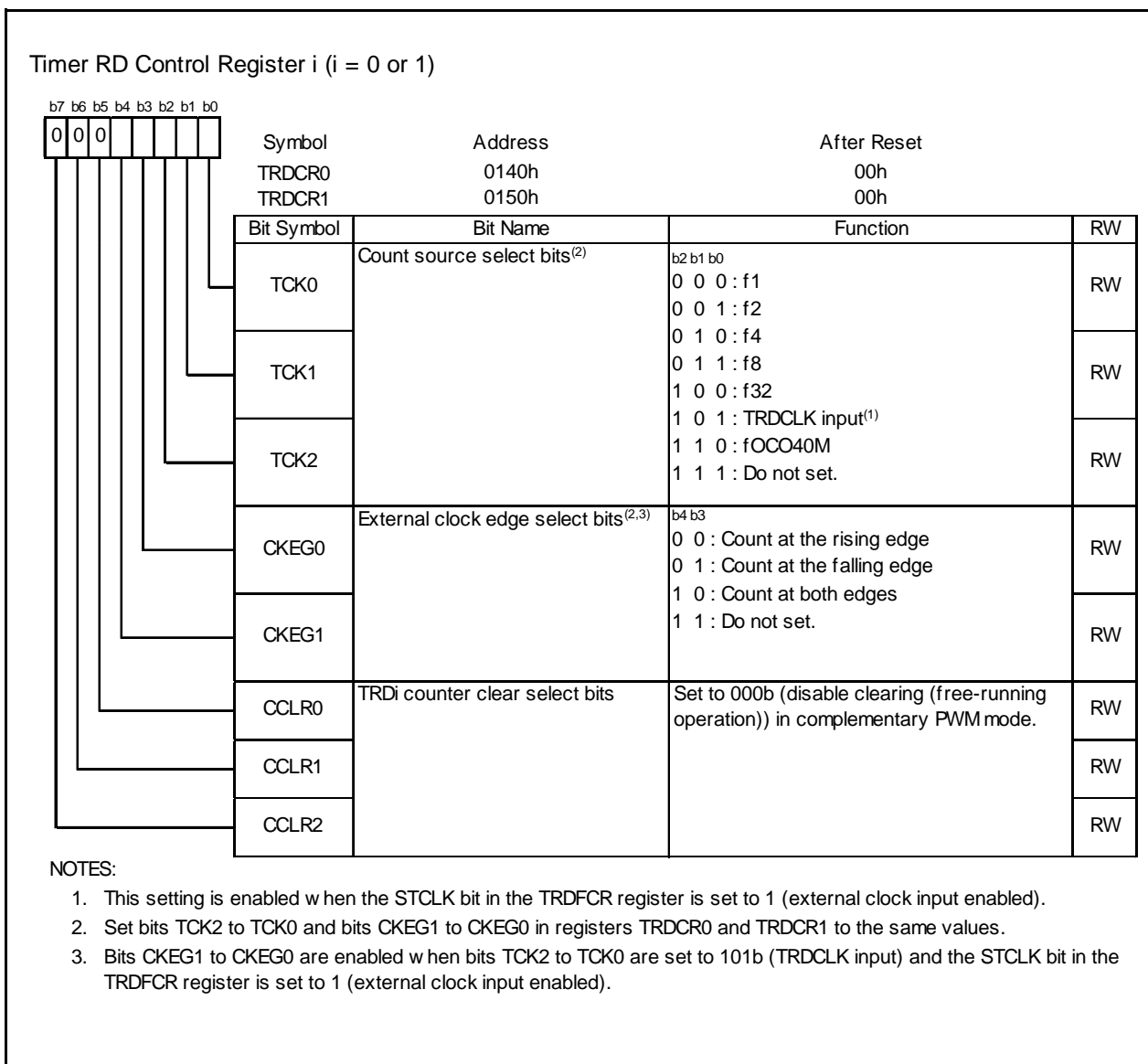

Figure 14.88 Registers TRDCR0 to TRDCR1 in Complementary PWM Mode

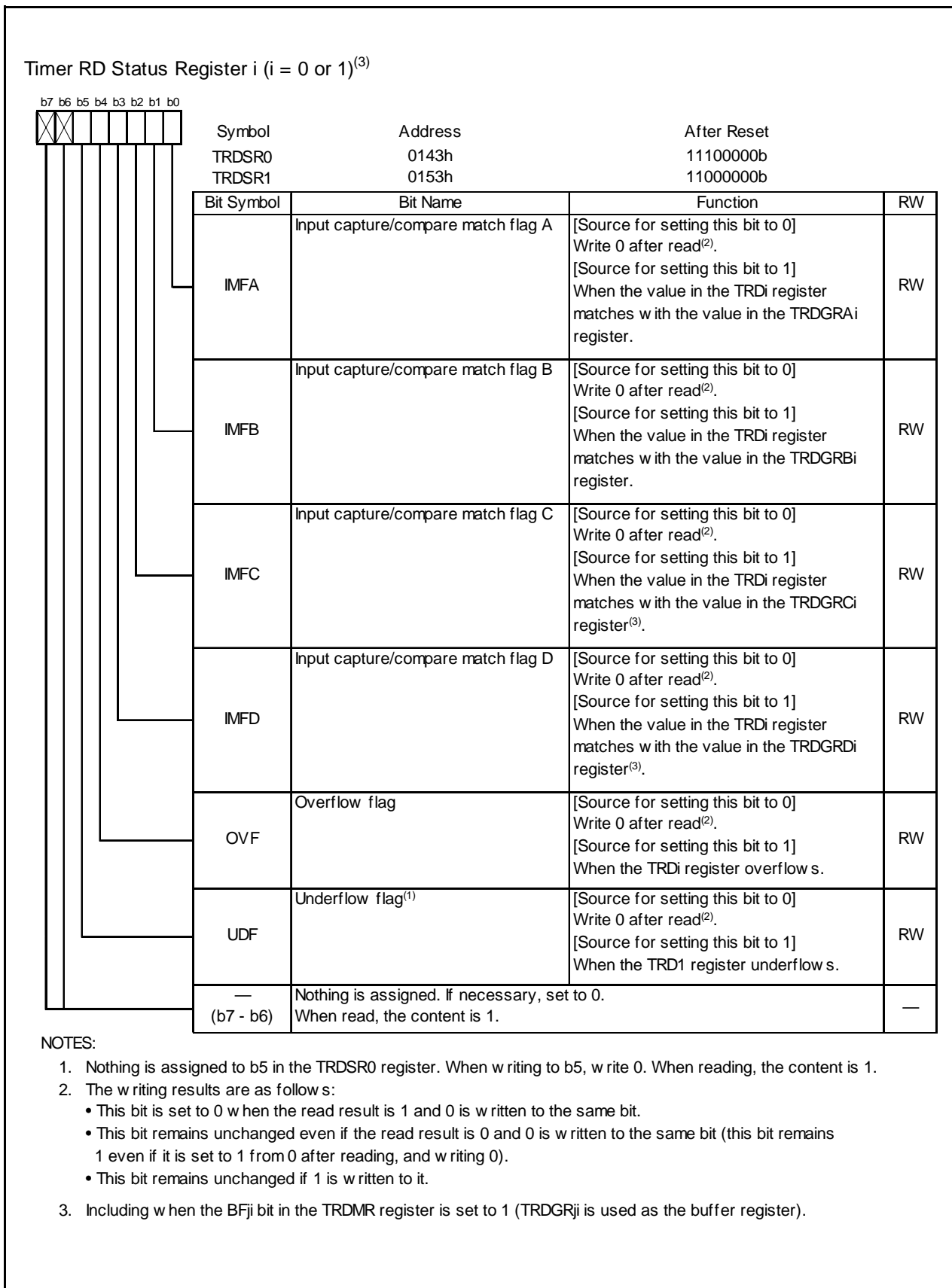

Figure 14.89 Registers TRDSR0 to TRDSR1 in Complementary PWM Mode

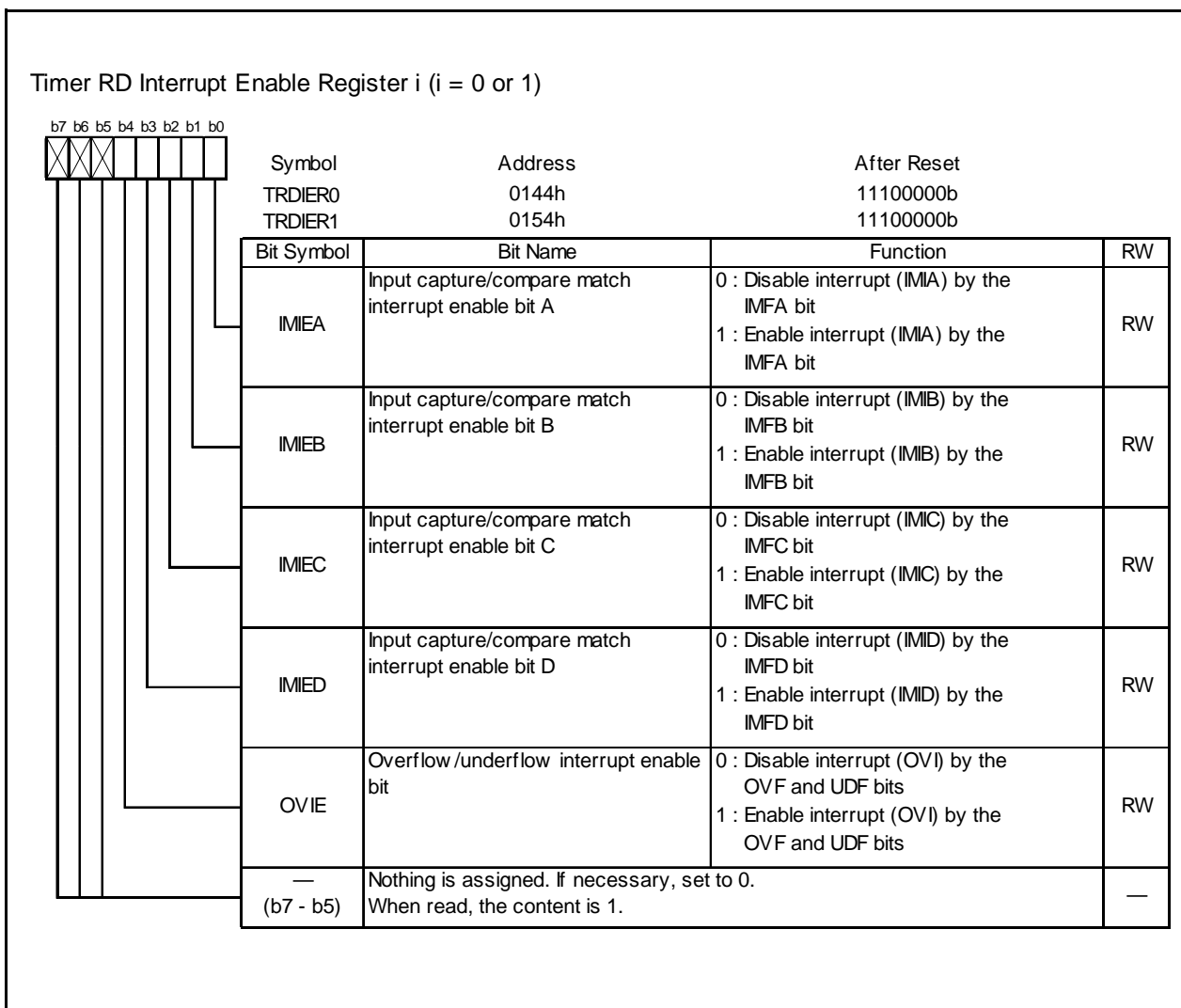

Figure 14.90 Registers TRDIER0 to TRDIER1 in Complementary PWM Mode

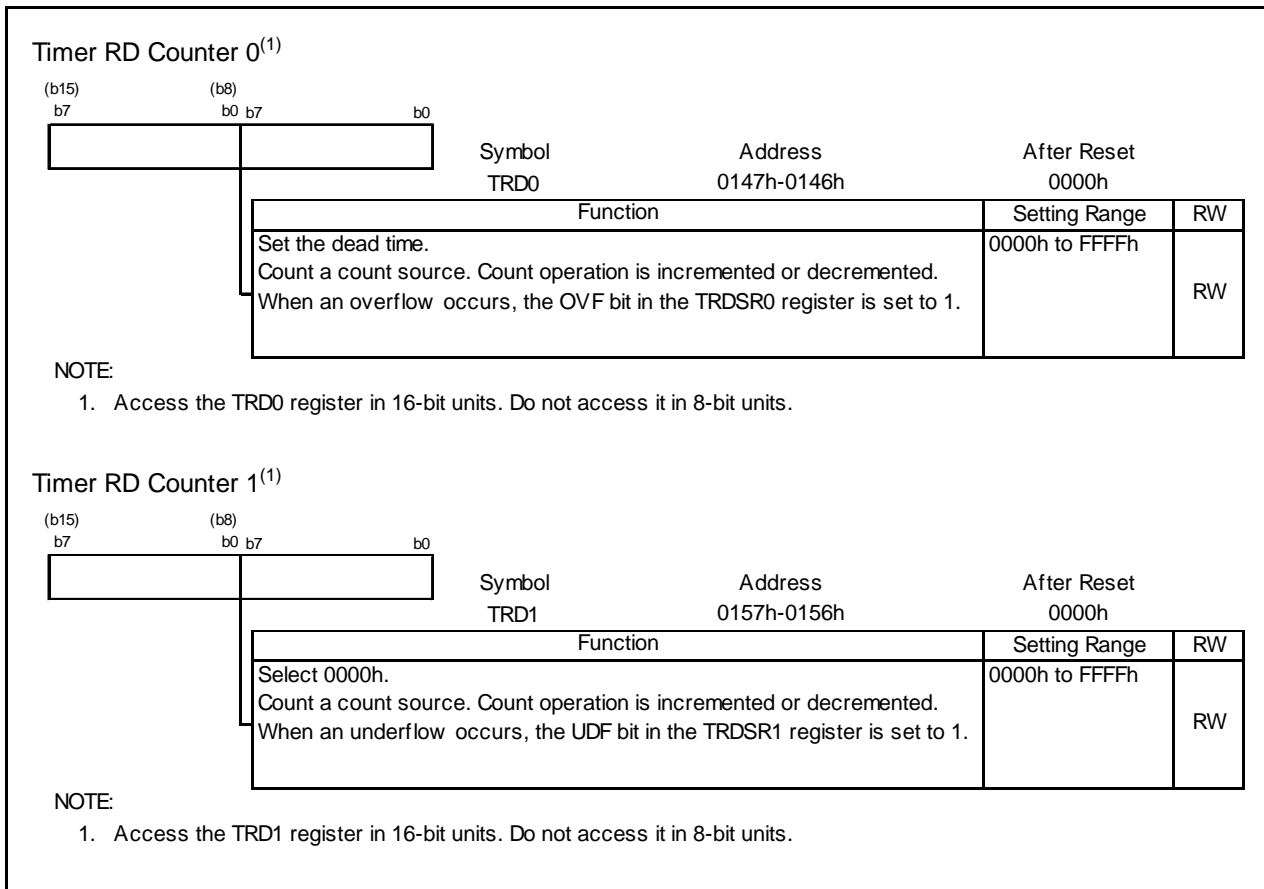

Figure 14.91 Registers TRD0 to TRD1 in Complementary PWM Mode

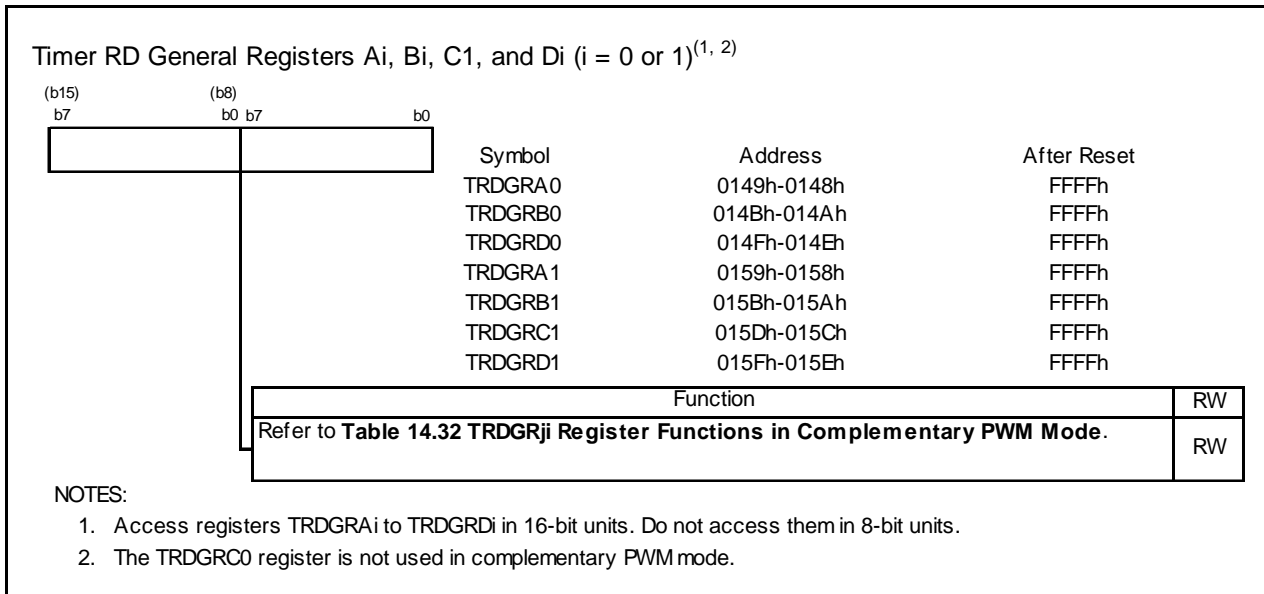

Figure 14.92 Registers TRDGRAi, TRDGRBi, TRDGRC1, and TRDGRDi in Complementary PWM Mode

The following registers are disabled in the complementary PWM mode: TRDPMR, TRDOCR, TRDDF0, TRDDF1, TRDIORA0, TRDIORC0, TRDPOCR0, TRDIORA1, TRDIORC1, and TRDPOCR1.

Table 14.32 TRDGR*j*i Register Functions in Complementary PWM Mode

Register	Setting	Register Function	PWM Output Pin
TRDGRA0	–	General register. Set the PWM period at initialization. Setting range: Setting value or above in TRD0 register FFFFh - TRD0 register setting value or below Do not write to this register when the TSTART0 and TSTART1 bits in the TRDSTR register are set to 1 (count starts).	(Output inverted every half period of TRDIOC0 pin)
TRDGRB0	–	General register. Set the changing point of PWM1 output at initialization. Setting range: Setting value or above in TRD0 register TRDGRA0 register - TRD0 register setting value or below Do not write to this register when the TSTART0 and TSTART1 bits in the TRDSTR register are set to 1 (count starts).	TRDIOB0 TRDIOD0
TRDGRA1	–	General register. Set the changing point of PWM2 output at initialization. Setting range: Setting value or above in TRD0 register TRDGRA0 register - TRD0 register setting value or below Do not write to this register when the TSTART0 and TSTART1 bits in the TRDSTR register are set to 1 (count starts).	TRDIOA1 TRDIOC1
TRDGRB1	–	General register. Set the changing point of PWM3 output at initialization. Setting range: Setting value or above in TRD0 register TRDGRA0 register - TRD0 register setting value or below Do not write to this register when the TSTART0 and TSTART1 bits in the TRDSTR register are set to 1 (count starts).	TRDIOB1 TRDIOD1
TRDGRC0	–	This register is not used in complementary PWM mode.	–
TRDGRD0	BFD0 = 1	Buffer register. Set the changing point of next PWM1 output. (Refer to 14.3.2 Buffer Operation .) Setting range: Setting value or above in TRD0 register TRDGRA0 register - TRD0 register setting value or below Set this register to the same value as the TRDGRB0 register for initialization.	TRDIOB0 TRDIOD0
TRDGRC1	BFC1 = 1	Buffer register. Set the changing point of next PWM2 output. (Refer to 14.3.2 Buffer Operation .) Setting range: Setting value or above in TRD0 register TRDGRA0 register - TRD0 register setting value or below Set this register to the same value as the TRDGRA1 register for initialization.	TRDIOA1 TRDIOC1
TRDGRD1	BFD1 = 1	Buffer register. Set the changing point of next PWM3 output. (Refer to 14.3.2 Buffer Operation .) Setting range: Setting value or above in TRD0 register TRDGRA0 register - TRD0 register setting value or below Set this register to the same value as the TRDGRB1 register for initialization.	TRDIOB1 TRDIOD1

BFC0, BFD0, BFC1, BFD1: Bits in TRDMR register

Since values cannot be written to the TRDGRB0, TRDGRA1, or TRDGRB1 register directly after count operation starts (prohibited item), use the TRDGRD0, TRDGRC1, or TRDGRD1 register as a buffer register. However, to write data to the TRDGRD0, TRDGRC1, or TRDGRD1 register, set bits BFD0, BFC1, and BFD1 to 0 (general register). After this, bits BFD0, BFC1, and BFD1 may be set to 1 (buffer register).

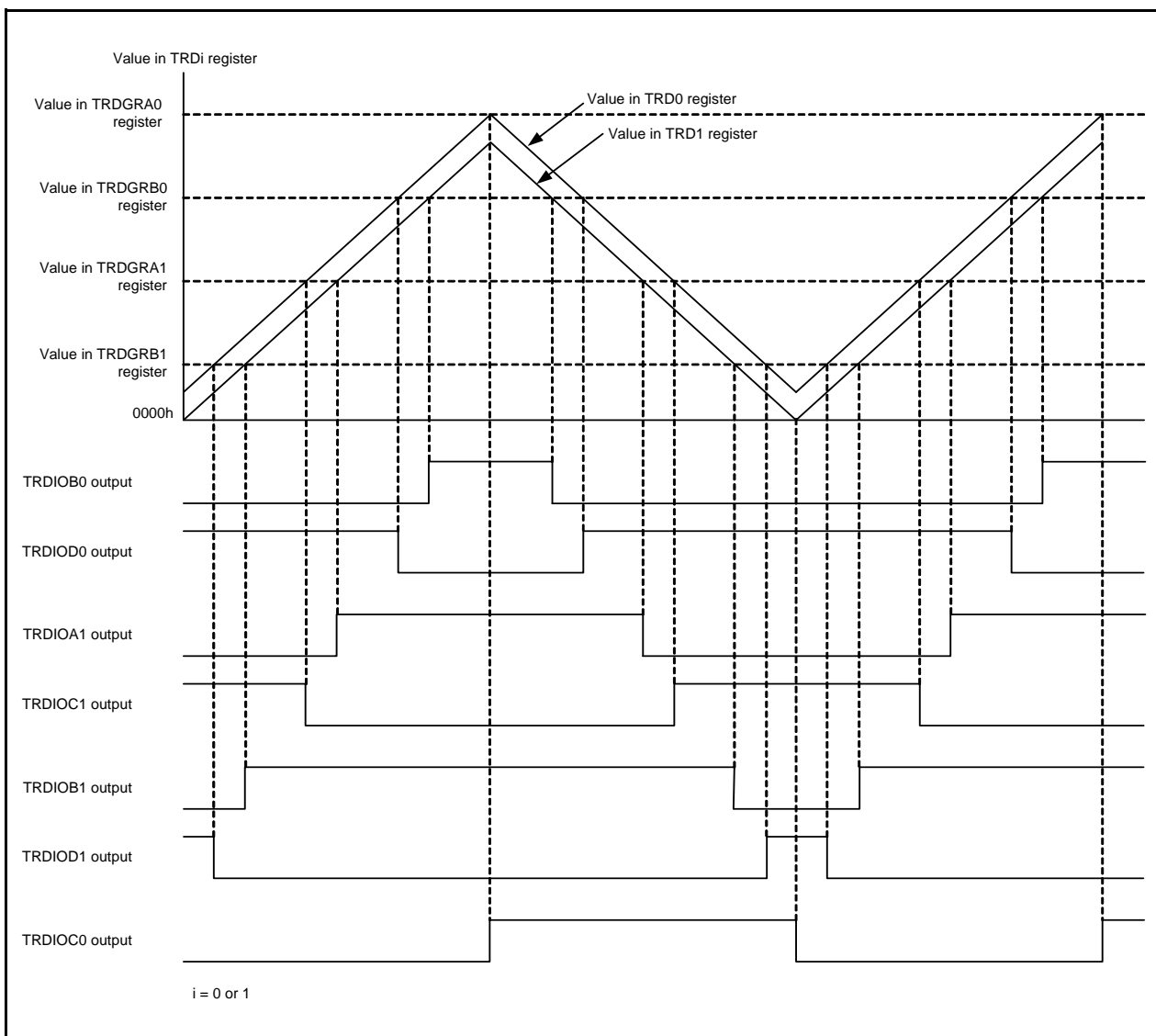

Figure 14.93 Output Model of Complementary PWM Mode

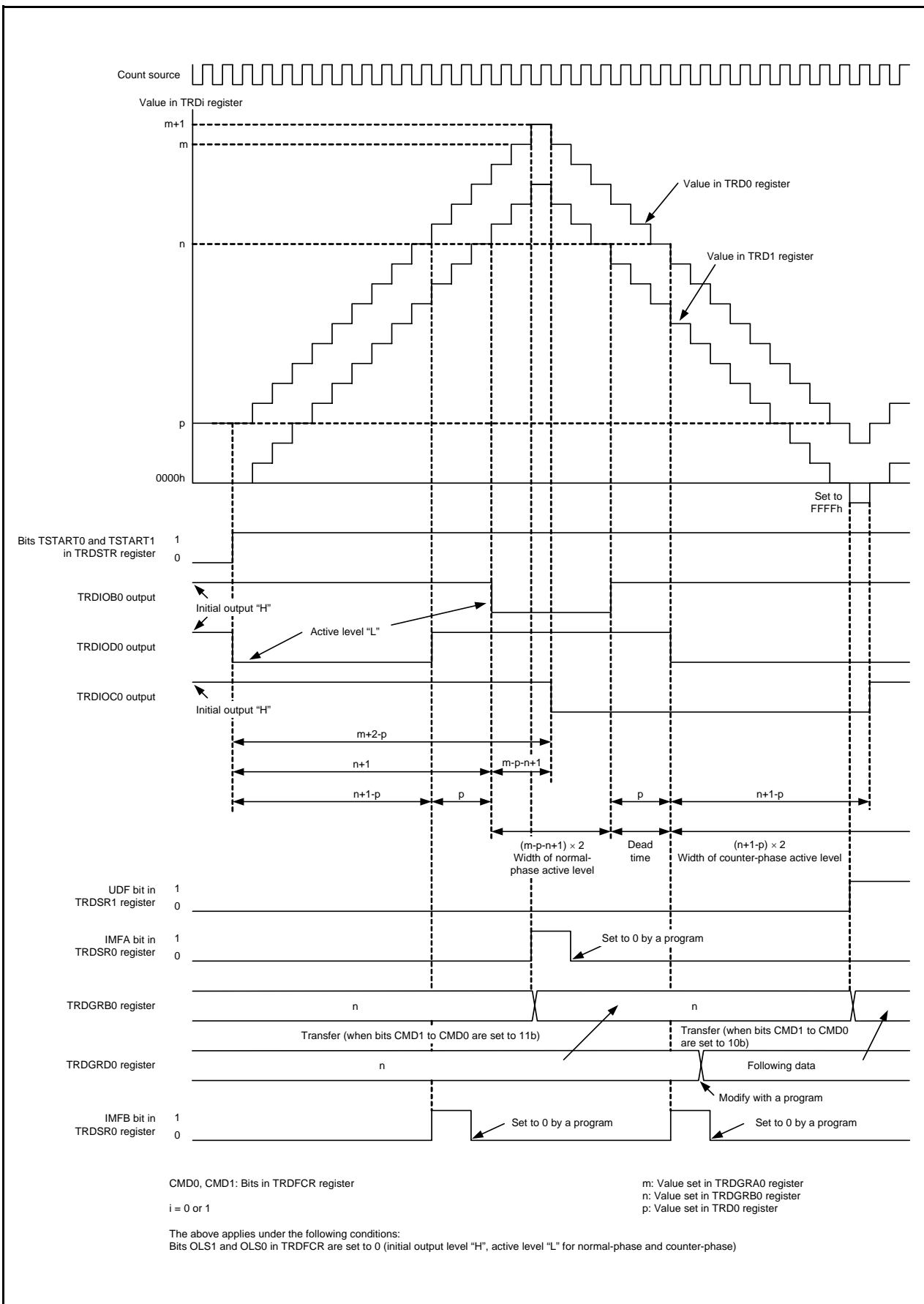

Figure 14.94 Operating Example of Complementary PWM Mode

14.3.9.1 Transfer Timing from Buffer Register

- Transfer from the TRDGRD0, TRDGRC1, or TRDGRD1 register to the TRDGRB0, TRDGRA1, or TRDGRB1 register.

When bits CMD1 to CMD0 in the TRDFCR register are set to 10b, the content is transferred when the TRD1 register underflows.

When bits CMD1 to CMD0 are set to 11b, the content is transferred at compare match between registers TRD0 and TRDGRA0.

14.3.9.2 A/D Trigger Generation

Compare match between registers TRD0 and TRDGRA0 and TRD1 underflow can be used as the conversion start trigger of the A/D converter. The trigger is selected by bits ADEG and ADTRG in the TRDFCR register. Also, set the ADCAP bit in the ADCON0 register to 1 (starts by timer RD).

14.3.10 PWM3 Mode

In this mode, 2 PWM waveforms are output with the same period.

Figure 14.95 shows a Block Diagram of PWM3 Mode, and Table 14.33 lists the PWM3 Mode Specifications. Figures 14.96 to 14.105 show the Registers Associated with PWM3 Mode, and Figure 14.106 shows an Operating Example of PWM3 Mode.

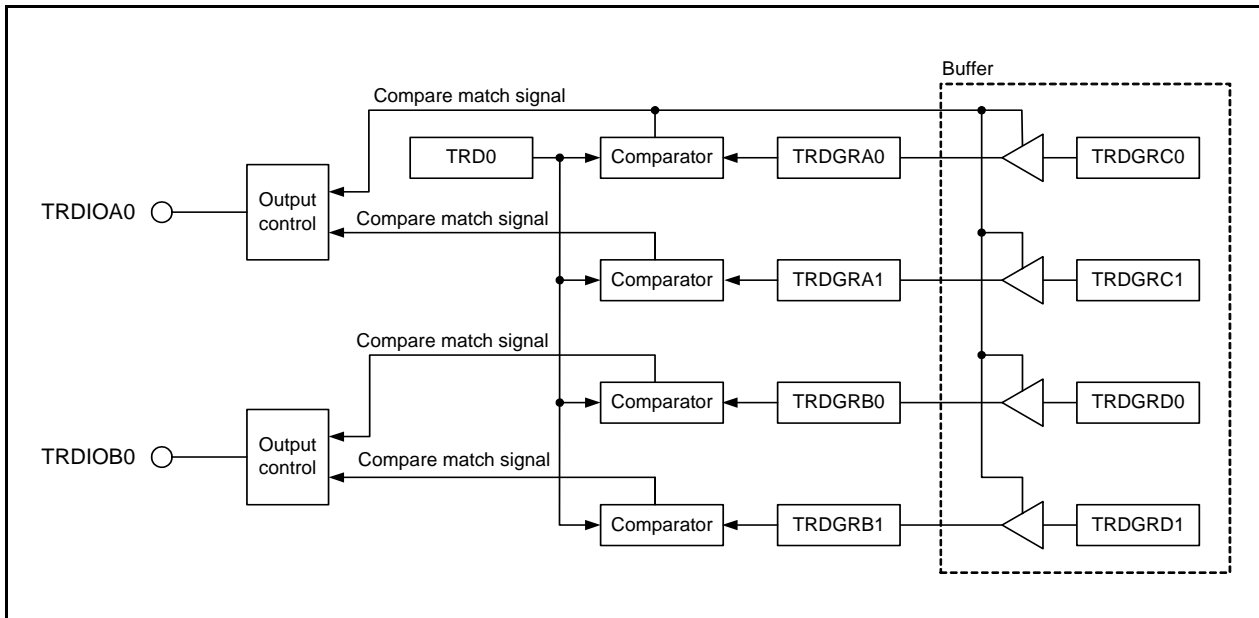
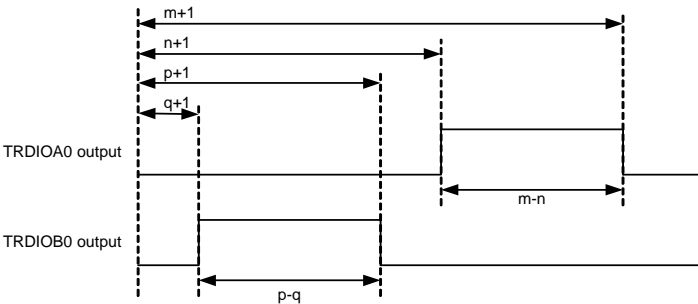

Figure 14.95 Block Diagram of PWM3 Mode

Table 14.33 PWM3 Mode Specifications

Item	Specification
Count sources	f1, f2, f4, f8, f32, fOCO40M
Count operations	The TRD0 register is incremented (the TRD1 is not used).
PWM waveform	<p>PWM period: $1/fk \times (m+1)$ Active level width of TRDIOA0 output: $1/fk \times (m-n)$ Active level width of TRDIOB0 output: $1/fk \times (p-q)$ fk: Frequency of count source m: Value set in the TRDGRA0 register n: Value set in the TRDGRA1 register p: Value set in the TRDGRB0 register q: Value set in the TRDGRB1 register</p>  <p>(When "H" is selected as the active level)</p>
Count start condition	1 (count starts) is written to the TSTART0 bit in the TRDSTR register.
Count stop conditions	<ul style="list-style-type: none"> • 0 (count stops) is written to the TSTART0 bit in the TRDSTR register when the CSEL0 bit in the TRDSTR register is set to 1. The PWM output pin holds output level before the count stops • When the CSEL0 bit in the TRDSTR register is set to 0, the count stops at the same time as the TRD0 register is set to 0000h at compare match with the TRDGRA0 register. The PWM output pin holds level after output change by compare match.
Interrupt request generation timing	<ul style="list-style-type: none"> • Compare match (The content of the TRDi register matches content of the TRDGRji register.) • The TRD0 register overflows
TRDIOA0, TRDIOB0 pin functions	PWM output
TRDIOC0, TRDIOD0, TRDIOA1 to TRDIOD1 pin functions	Programmable I/O port
INT0 pin function	Programmable I/O port, pulse output forced cutoff signal input, or INT0 interrupt input
Read from timer	The count value can be read by reading the TRD0 register.
Write to timer	The value can be written to the TRD0 register.
Select functions	<ul style="list-style-type: none"> • Pulse output forced cutoff signal input (Refer to 14.3.4 Pulse Output Forced Cutoff.) • Buffer Operation (Refer to 14.3.2 Buffer Operation.) • Active level selectable by pin

i = 0 or 1, j = either A, B, C, or D

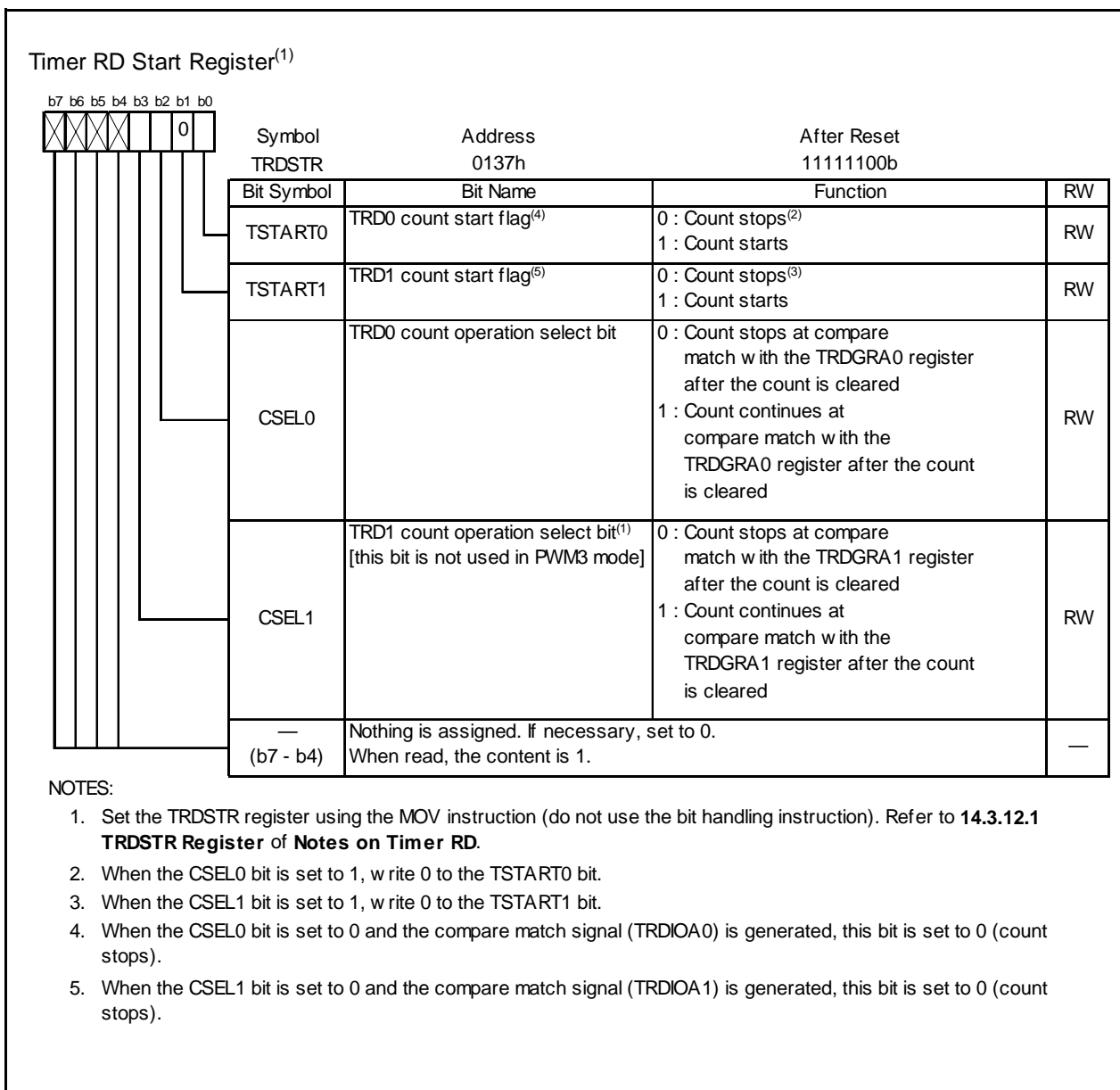

Figure 14.96 TRDSTR Register in PWM3 Mode

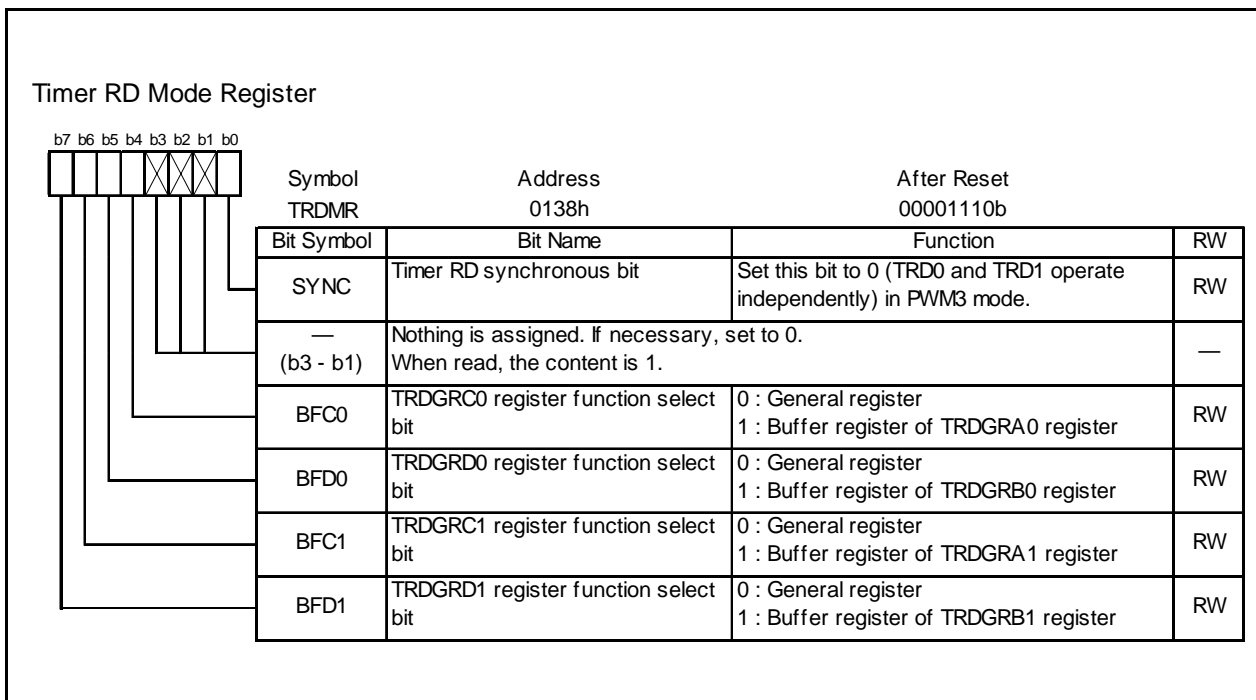

Figure 14.97 TRDMR Register in PWM3 Mode

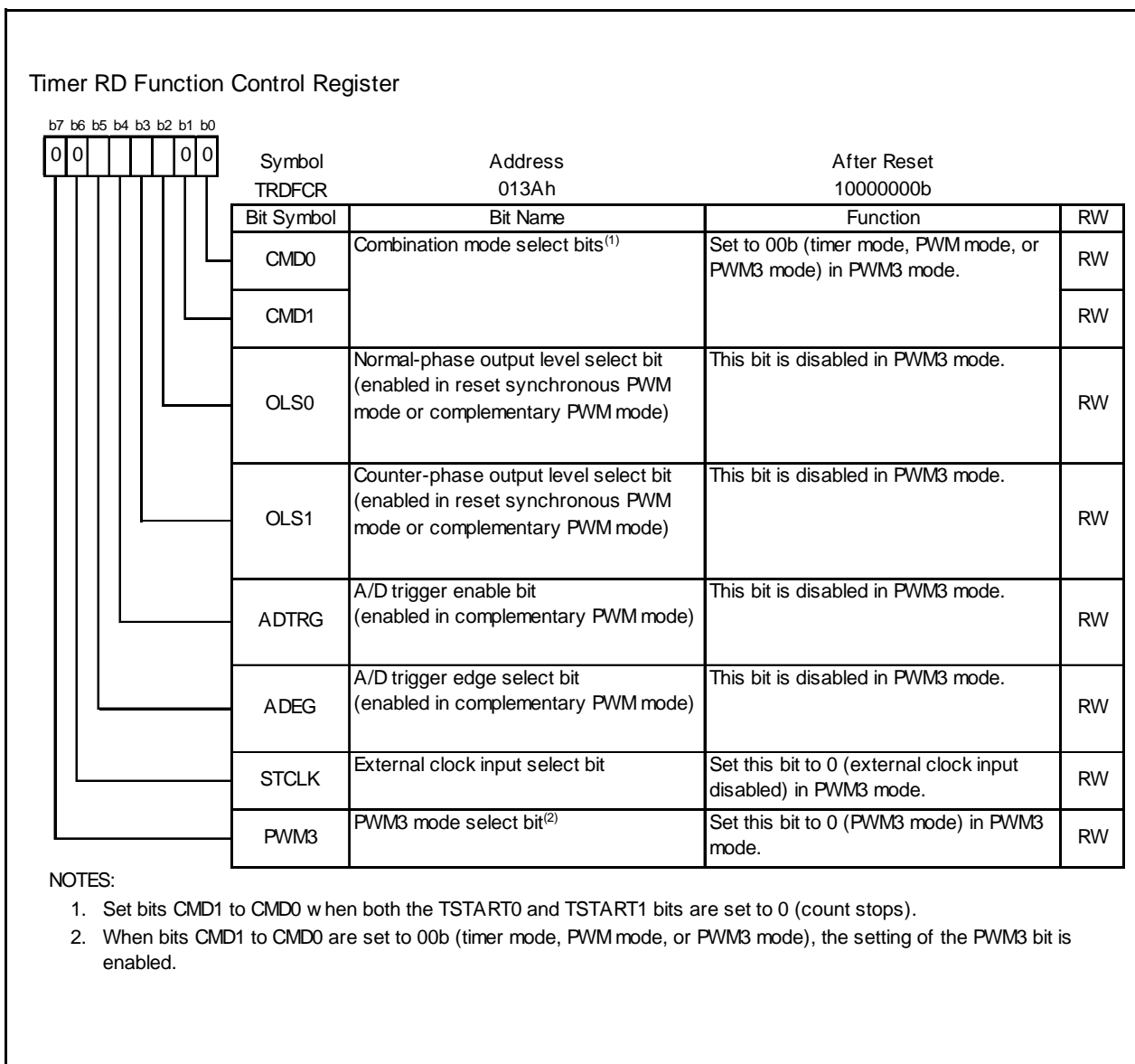

Figure 14.98 TRDFCR Register in PWM3 Mode

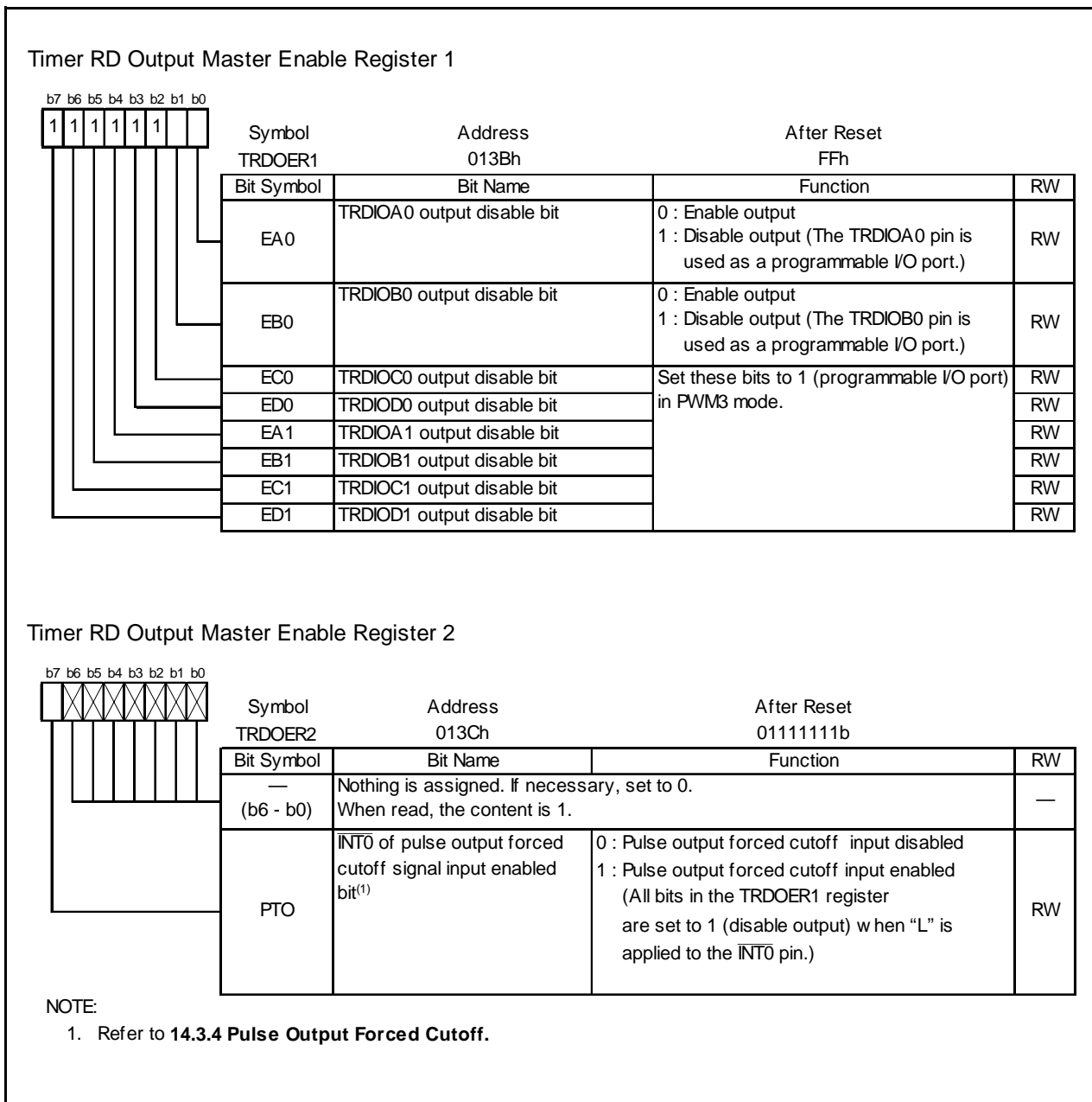

Figure 14.99 Registers TRDOER1 to TRDOER2 in PWM3 Mode

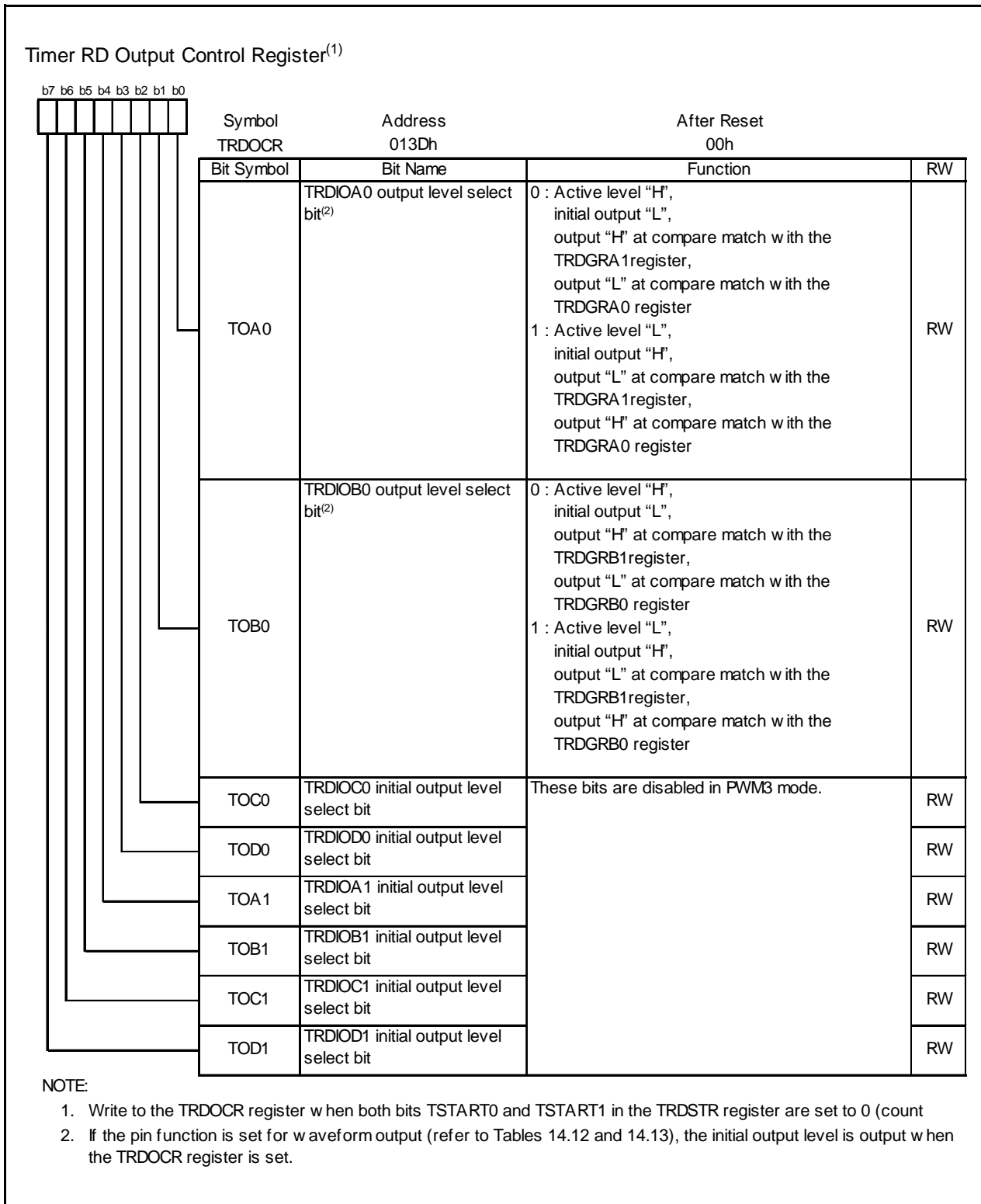

Figure 14.100 TRDOCR Register in PWM3 Mode

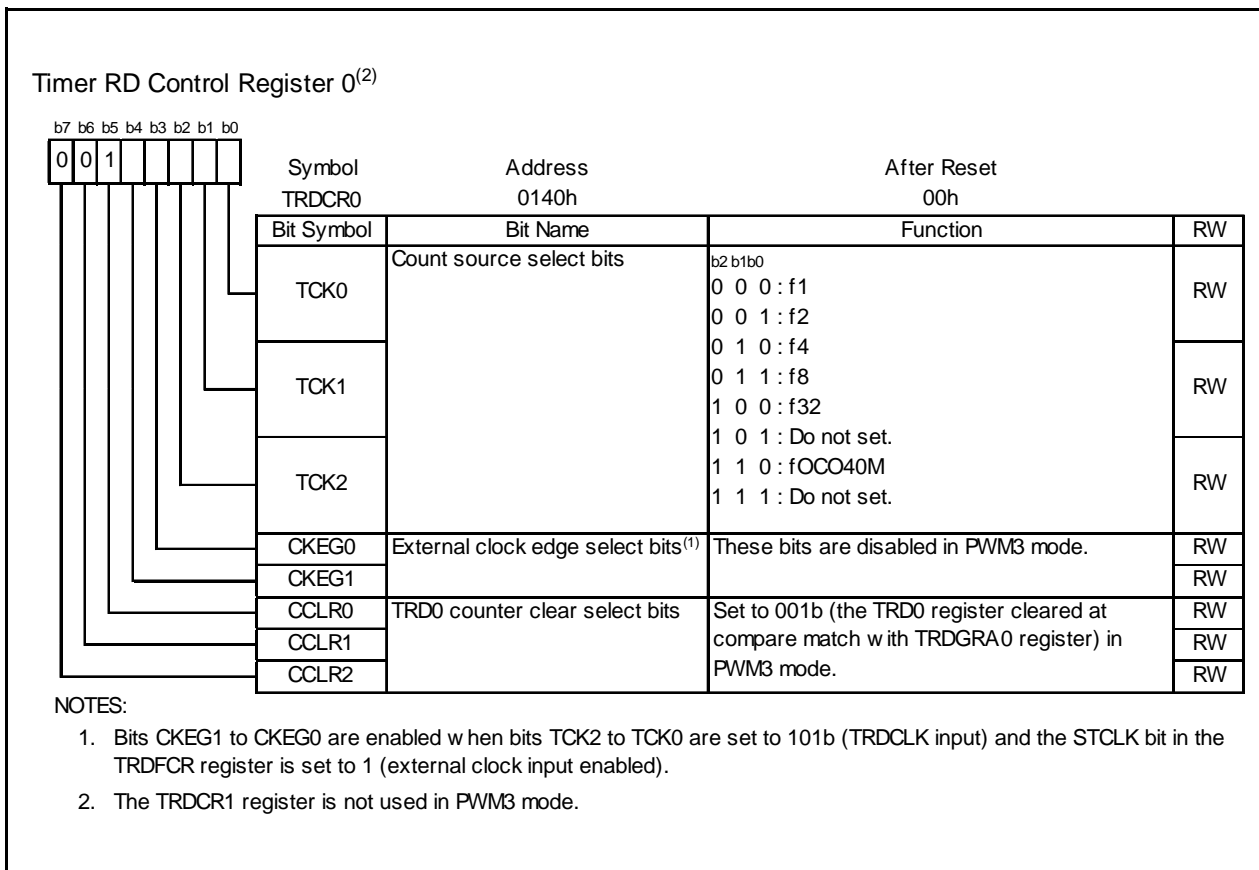

Figure 14.101 TRDCR0 Register in PWM3 Mode

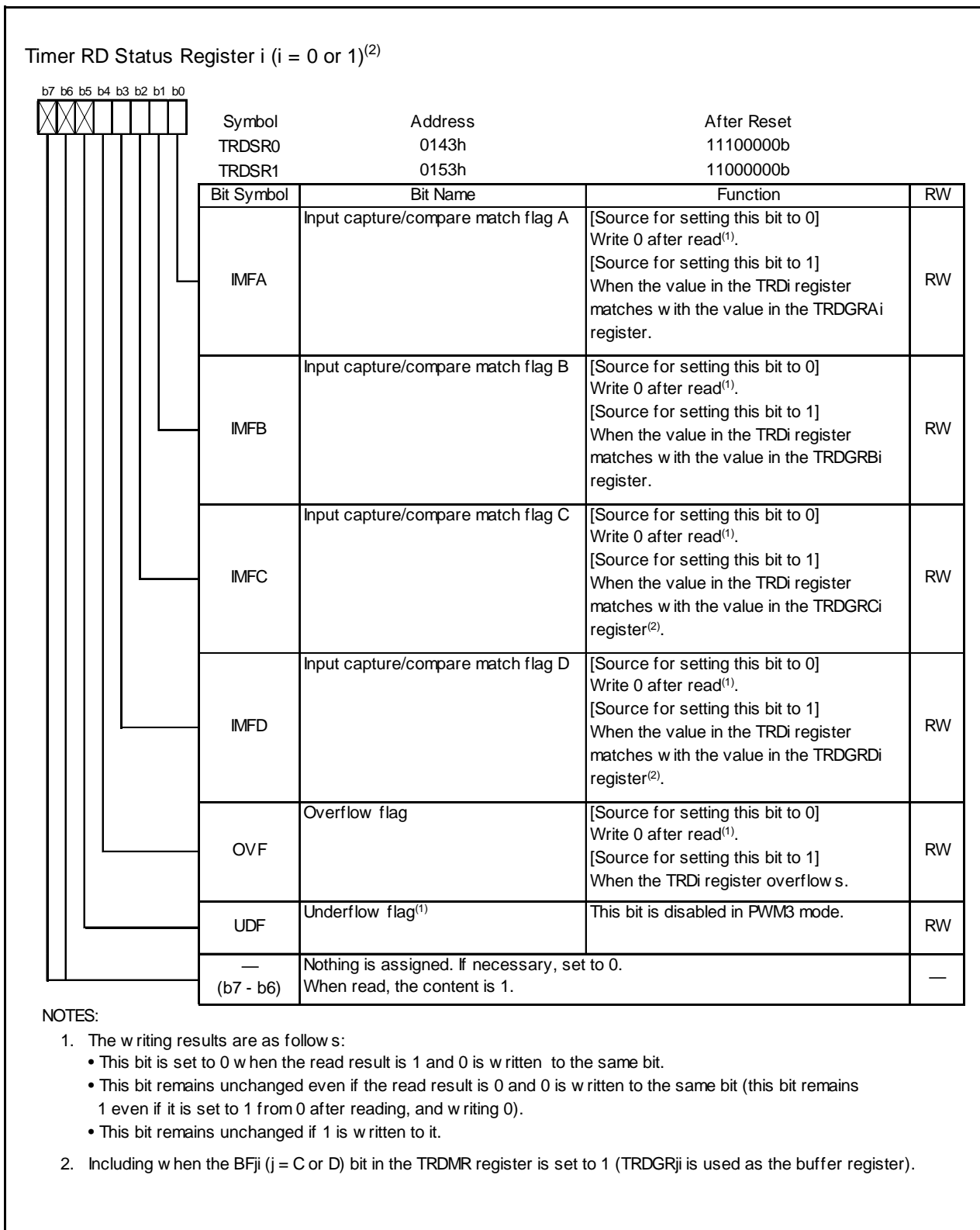

Figure 14.102 Registers TRDSR0 to TRDSR1 in PWM3 Mode

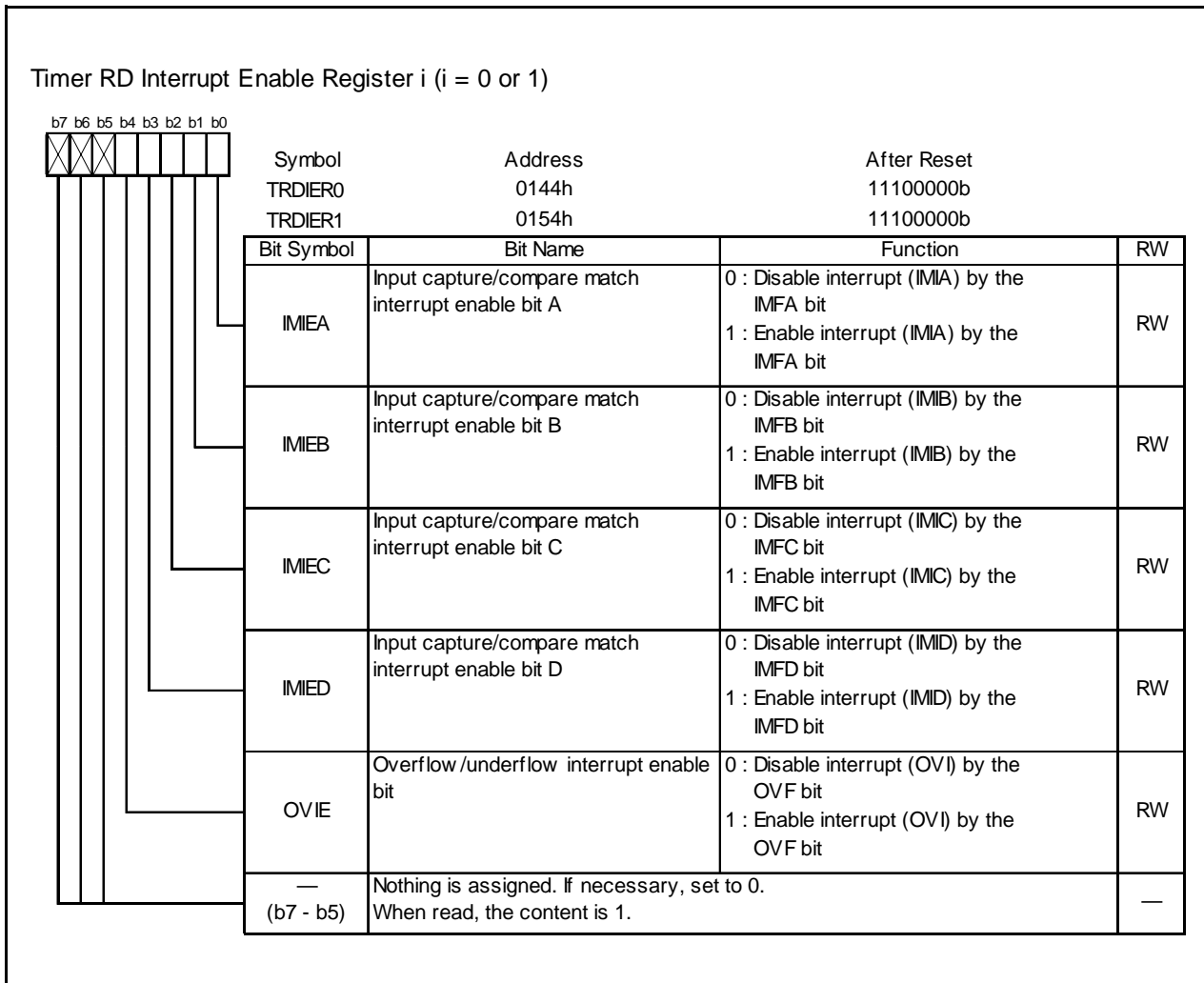

Figure 14.103 Registers TRDIER0 to TRDIER1 in PWM3 Mode

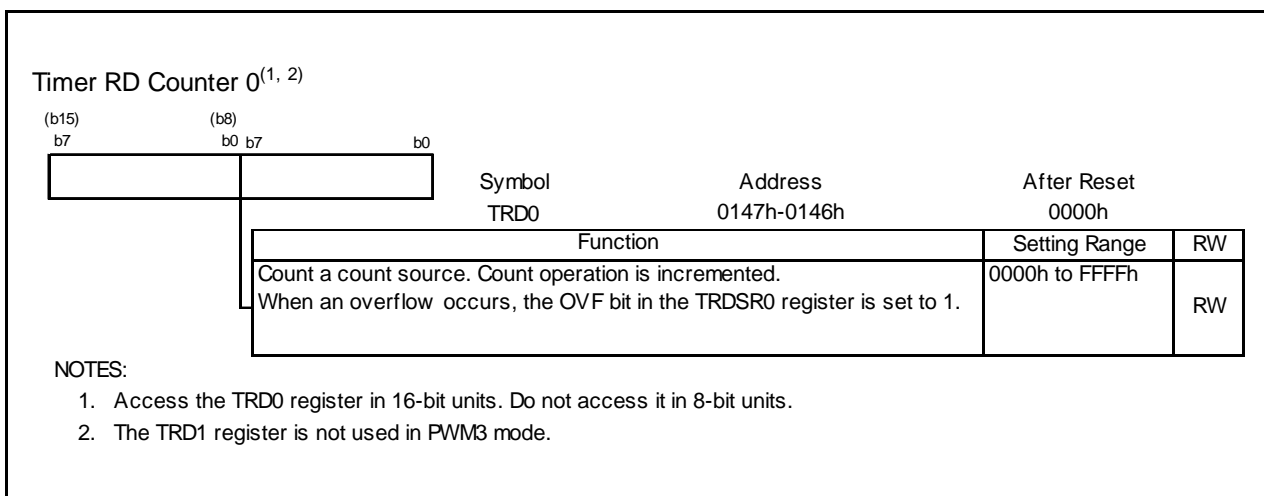

Figure 14.104 TRD0 Register in PWM3 Mode

Timer RD General Registers Ai, Bi, Ci, and Di (i = 0 or 1)⁽¹⁾

<table border="1"> <tr> <td>(b15) b7</td> <td>(b8) b0 b7</td> <td>b0</td> </tr> </table>		(b15) b7	(b8) b0 b7	b0	Symbol	Address	After Reset
(b15) b7	(b8) b0 b7	b0					
	TRDGRA0	0149h-0148h	FFFFh				
	TRDGRB0	014Bh-014Ah	FFFFh				
	TRDGRC0	014Dh-014Ch	FFFFh				
	TRDGRD0	014Fh-014Eh	FFFFh				
	TRDGRA1	0159h-0158h	FFFFh				
	TRDGRB1	015Bh-015Ah	FFFFh				
	TRDGRC1	015Dh-015Ch	FFFFh				
	TRDGRD1	015Fh-015Eh	FFFFh				
Function			RW				
Refer to Table 14.34 TRDGRji Register Functions in PWM3 mode.			RW				

NOTE:
1. Access registers TRDGRAi to TRDGRDi in 16-bit units. Do not access them in 8-bit units.

Figure 14.105 Registers TRDGRAi, TRDGRBi, TRDGRCi, and TRDGRDi in PWM3 Mode

The following registers are disabled in the PWM3 mode function: TRDPMR, TRDDF0, TRDDF1, TRDIORA0, TRDIORC0, TRDPOCR0, TRDIORA1, TRDIORC1, and TRDPOCR1.

Table 14.34 TRDGR_{ji} Register Functions in PWM3 Mode

Register	Setting	Register Function	PWM Output Pin
TRDGRA0	–	General register. Set the PWM period. Setting range: Value set in TRDGRA1 register or above	TRDIOA0
TRDGRA1		General register. Set the changing point (the active level timing) of PWM output. Setting range: Value set in TRDGRA0 register or below	
TRDGRB0		General register. Set the changing point (the timing that returns to initial output level) of PWM output. Setting range: Value set in TRDGRB1 register or above Value set in TRDGRA0 register or below	TRDIOB0
TRDGRB1		General register. Set the changing point (active level timing) of PWM output. Setting range: Value set in TRDGRB0 register or below	
TRDGRC0	BFC0 = 0	(These registers is not used in PWM3 mode.)	–
TRDGRC1	BFC1 = 0		
TRDGRD0	BFD0 = 0		
TRDGRD1	BFD1 = 0		
TRDGRC0	BFC0 = 1	Buffer register. Set the next PWM period. (Refer to 14.3.2 Buffer Operation.) Setting range: Value set in TRDGRC1 register or above	TRDIOA0
TRDGRC1	BFC1 = 1	Buffer register. Set the changing point of next PWM output. (Refer to 14.3.2 Buffer Operation.) Setting range: Value set in TRDGRC0 register or below	
TRDGRD0	BFD0 = 1	Buffer register. Set the changing point of next PWM output. (Refer to 14.3.2 Buffer Operation.) Setting range: Value set in TRDGRD1 register or above, setting value or below in TRDGRC0 register.	TRDIOB0
TRDGRD1	BFD1 = 1	Buffer register. Set the changing point of next PWM output. (Refer to 14.3.2 Buffer Operation.) Setting range: Value set in TRDGRD0 register or below	

BFC0, BFD0, BFC1, BFD1: Bits in TRDMR register

Registers TRDGRC0, TRDGRC1, TRDGRD0, and TRDGRD1 are not used in PWM3 mode. To use them as buffer registers, set bits BFC0, BFC1, BFD0, and BFD1 to 0 (general register) and write a value to the TRDGRC0, TRDGRC1, TRDGRD0, or TRDGRD1 register. After this, bits BFC0, BFC1, BFD0, and BFD1 may be set to 1 (buffer register).

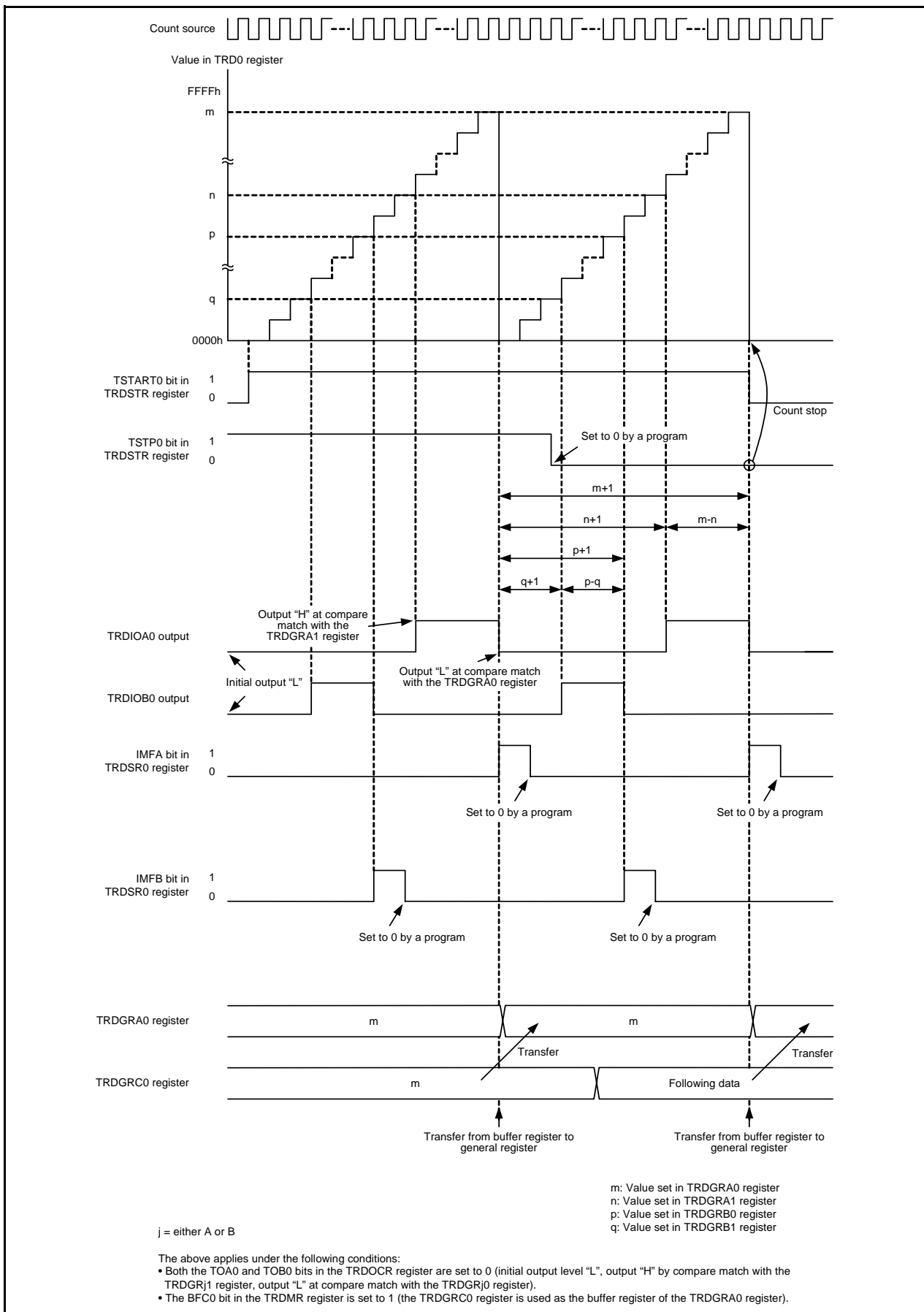

Figure 14.106 Operating Example of PWM3 Mode

14.3.11 Timer RD Interrupt

Timer RD generates the timer RD interrupt request based on 6 sources for each channel. The timer RD interrupt has 1 TRDiIC register (bits IR, and ILVL0 to ILVL2), and 1 vector for each channel. Table 14.35 lists the Registers Associated with Timer RD Interrupt, and Figure 14.107 shows a Block Diagram of Timer RD Interrupt.

Table 14.35 Registers Associated with Timer RD Interrupt

	Timer RD Status Register	Timer RD Interrupt Enable Register	Timer RD Interrupt Control Register
Channel 0	TRDSR0	TRDIER0	TRD0IC
Channel 1	TRDSR1	TRDIER1	TRD1IC

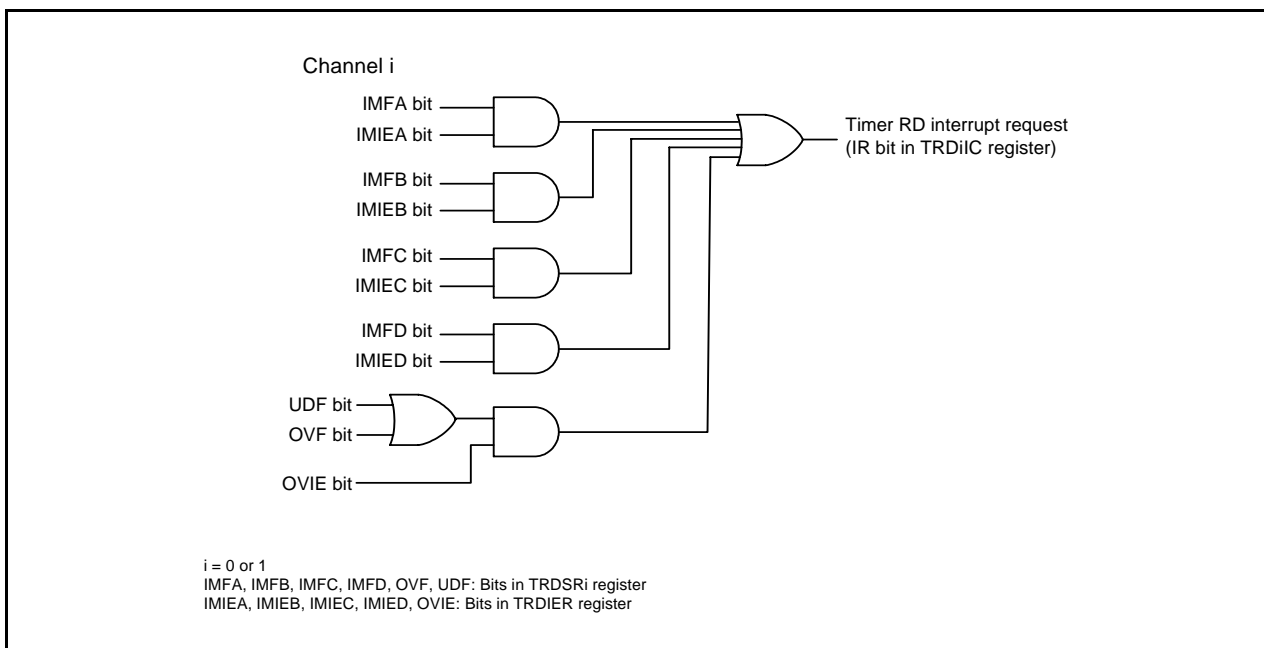

Figure 14.107 Block Diagram of Timer RD Interrupt

As with other maskable interrupts, the timer RD interrupt is controlled by the combination of the I flag, IR bit, bits ILVL0 to ILVL2, and IPL. However, since the interrupt source (timer RD interrupt) is generated by a combination of multiple interrupt request sources, the following differences from other maskable interrupts apply:

- When bits in the TRDSR $_i$ register corresponding to bits set to 1 in the TRDIER $_i$ register are set to 1 (enable interrupt), the IR bit in the TRDiIC register is set to 1 (interrupt requested).
- When either bits in the TRDSR $_i$ register or bits in the TRDIER $_i$ register corresponding to bits in the TRDSR $_i$ register, or both of them, are set to 0, the IR bit is set to 0 (interrupt not requested). Therefore, even though the interrupt is not acknowledged after the IR bit is set to 1, the interrupt request will not be maintained.
- When the conditions of other request sources are met, the IR bit remains 1.
- When multiple bits in the TRDIER $_i$ register are set to 1, which request source causes an interrupt is determined by the TRDSR $_i$ register.
- Since each bit in the TRDSR $_i$ register is not automatically set to 0 even if the interrupt is acknowledged, set each bit to 0 in the interrupt routine. For information on how to set these bits to 0, refer to the descriptions of the registers used in the different modes (**Figures 14.38, 14.53, 14.65, 14.77, 14.87, and 14.98**).

Refer to **Registers TRDSR0 to TRDSR1 in each mode (Figures 14.38, 14.53, 14.65, 14.77, 14.88, and 14.100)** for the TRDSR_i register. Refer to **Registers TRDIER0 to TRDIER1 in each mode (Figures 14.39, 14.54, 14.66, 14.78, 14.89, and 14.101)** for the TRDIER_i register.

Refer to **12.1.6 Interrupt Control** for information on the TRDiC register and **12.1.5.2 Relocatable Vector Tables** for the interrupt vectors.

14.3.12 Notes on Timer RD

14.3.12.1 TRDSTR Register

- Set the TRDSTR register using the MOV instruction.
- When the CSEL_i ($i = 0$ to 1) is set to 0 (the count stops after the count is cleared at compare match of registers TRD_i and TRDGRA_i), the count does not stop and the TSTART_i bit remains unchanged even if 0 (count stops) is written to the TSTART_i bit.
- Therefore, set the TSTART_i bit to 0 to change other bits without changing the TSTART_i bit when the CSEL_i bit is set to 0 .
- To stop counting by a program, set the TSTART_i bit after setting the CSEL_i bit to 1 . Although the CSEL_i bit is set to 1 and the TSTART_i bit is set to 0 at the same time (with 1 instruction), the count cannot be stopped.
- Table 14.36 lists the TRDIO_j ($j = A, B, C, \text{ or } D$) Pin Output Level when Count Stops to use the TRDIO_j ($j = A, B, C, \text{ or } D$) pin with the timer RD output.

Table 14.36 TRDIO_j ($j = A, B, C, \text{ or } D$) Pin Output Level when Count Stops

Count Stop	TRDIO _j Pin Output when Count Stops
When the CSEL _i bit is set to 1 , set the TSTART _i bit to 0 and the count stops.	Hold the output level immediately before the count stops.
When the CSEL _i bit is set to 0 , the count stops after the count is cleared at compare match of registers TRD _i and TRDGRA _i .	Hold the output level after output changes by compare match.

14.3.12.2 TRD_i Register ($i = 0$ or 1)

- When writing the value to the TRD_i register by a program while the TSTART_i bit in the TRDSTR register is set to 1 (count starts), avoid overlapping with the timing for setting the TRD_i register to $0000h$, and then write. If the timing for setting the TRD_i register to $0000h$ overlaps with the timing for writing the value to the TRD_i register, the value is not written and the TRD_i register is set to $0000h$.
These precautions are applicable when selecting the following by bits CCLR2 to CCLR0 in the TRDCR_i register.
 - $001b$ (Clear by the TRD_i register at compare match with the TRDGRA_i register.)
 - $010b$ (Clear by the TRD_i register at compare match with the TRDGRB_i register.)
 - $011b$ (Synchronous clear)
 - $101b$ (Clear by the TRD_i register at compare match with the TRDGRC_i register.)
 - $110b$ (Clear by the TRD_i register at compare match with the TRDGRD_i register.)
- When writing the value to the TRD_i register and continuously reading the same register, the value before writing may be read. In this case, execute the JMP.B instruction between the writing and reading.

```

Program example      MOV.W      #XXXXh, TRD0      ;Writing
                    JMP.B      L1                ;JMP.B
                    L1:      MOV.W      TRD0,DATA    ;Reading
  
```

14.3.12.3 TRDSR_i Register ($i = 0$ or 1)

When writing the value to the TRDSR_i register and continuously reading the same register, the value before writing may be read. In this case, execute the JMP.B instruction between the writing and reading.

```

Program example      MOV.B      #XXh, TRDSR0    ;Writing
                    JMP.B      L1                ;JMP.B
                    L1:      MOV.B      TRDSR0,DATA ;Reading
  
```

14.3.12.4 Count Source Switch

- Switch the count source after the count stops.

Change procedure

- (1) Set the TSTART_i (i = 0 or 1) bit in the TRDSTR register to 0 (count stops).
- (2) Change bits TCK2 to TCK0 in the TRDCR_i register.

- When changing the count source from fOCO40M to another source and stopping fOCO40M, wait 2 cycles of f₁ or more after setting the clock switch, and then stop fOCO40M.

Change procedure

- (1) Set the TSTART_i (i = 0 or 1) bit in the TRDSTR register to 0 (count stops).
- (2) Change bits TCK2 to TCK0 in the TRDCR_i register.
- (3) Wait 2 or more cycles of f₁.
- (4) Set the FRA00 bit in the FRA0 register to 0 (high-speed on-chip oscillator stops).

14.3.12.5 Input Capture Function

- Set the pulse width of the input capture signal to 3 or more cycles of the timer RD operation clock (refer to **Table 14.11 Timer RD Operation Clocks**).
- The value in the TRD_i register is transferred to the TRDGR_{ji} register 2 to 3 cycles of the timer RD operation clock after the input capture signal is applied to the TRDIO_{ji} pin (i = 0 or 1, j = either A, B, C, or D) (no digital filter).

14.3.12.6 Reset Synchronous PWM Mode

- When reset synchronous PWM mode is used for motor control, make sure OLS0 = OLS1.
- Set to reset synchronous PWM mode by the following procedure:

Change procedure

- (1) Set the TSTART0 bit in the TRDSTR register to 0 (count stops).
- (2) Set bits CMD1 to CMD0 in the TRDFCR register to 00b (timer mode, PWM mode, and PWM3 mode).
- (3) Set bits CMD1 to CMD0 to 01b (reset synchronous PWM mode).
- (4) Set the other registers associated with timer RD again.

14.3.12.7 Complementary PWM Mode

- When complementary PWM mode is used for motor control, make sure OLS0 = OLS1.
- Change bits CMD1 to CMD0 in the TRDFCR register in the following procedure.

Change procedure: When setting to complementary PWM mode (including re-set), or changing the transfer timing from the buffer register to the general register in complementary PWM mode.

- (1) Set both the TSTART0 and TSTART1 bits in the TRDSTR register to 0 (count stops).
- (2) Set bits CMD1 to CMD0 in the TRDFCR register to 00b (timer mode, PWM mode, and PWM3 mode).
- (3) Set bits CMD1 to CMD0 to 10b or 11b (complementary PWM mode).
- (4) Set the registers associated with other timer RD again.

Change procedure: When stopping complementary PWM mode

- (1) Set both the TSTART0 and TSTART1 bits in the TRDSTR register to 0 (count stops).
- (2) Set bits CMD1 to CMD0 to 00b (timer mode, PWM mode, and PWM3 mode).

- Do not write to TRDGRA0, TRDGRB0, TRDGRA1, or TRDGRB1 register during operation. When changing the PWM waveform, transfer the values written to registers TRDGRD0, TRDGRC1, and TRDGRD1 to registers TRDGRB0, TRDGRA1, and TRDGRB1 using the buffer operation. However, to write data to the TRDGRD0, TRDGRC1, or TRDGRD1 register, set bits BFD0, BFC1, and BFD1 to 0 (general register). After this, bits BFD0, BFC1, and BFD1 may be set to 1 (buffer register). The PWM period cannot be changed.

- If the value in the TRDGRA0 register is assumed to be m , the TRD0 register counts $m-1$, m , $m+1$, m , $m-1$, in that order, when changing from increment to decrement operation.

When changing from m to $m+1$, the IMFA bit is set to 1. Also, bits CMD1 to CMD0 in the TRDFCR register are set to 11b (complementary PWM mode, buffer data transferred at compare match between registers TRD0 and TRDGRA0), the content in the buffer registers (TRDGRD0, TRDGRC1, and TRDGRD1) is transferred to the general registers (TRDGRB0, TRDGRA1, and TRDGRB1).

During $m+1$, m , and $m-1$ operation, the IMFA bit remains unchanged and data are not transferred to registers such as the TRDGRA0 register.

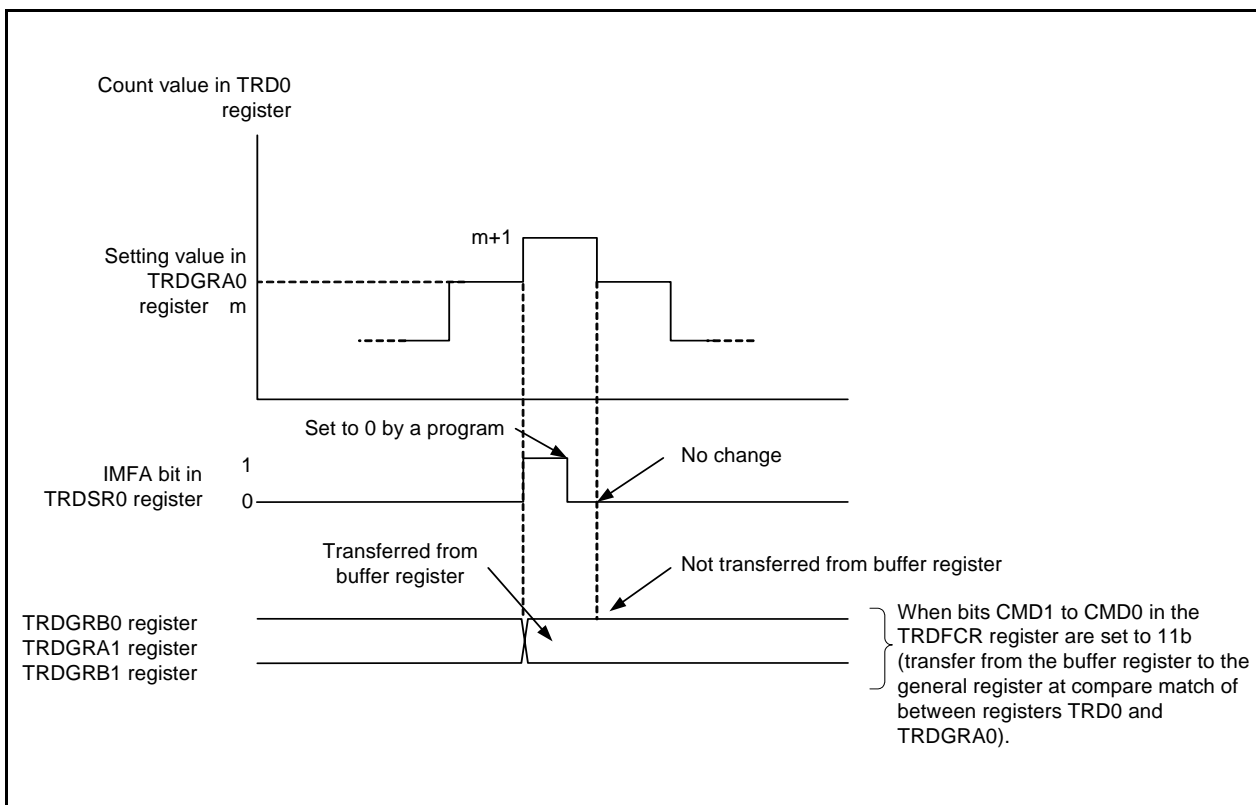

Figure 14.108 Operation at Compare Match between Registers TRD0 and TRDGRA0 in Complementary PWM Mode

- The TRD1 register counts 1, 0, FFFFh, 0, 1, in that order, when changing from decrement to increment operation.

The UDF bit is set to 1 when changing between 1, 0, and FFFFh operation. Also, when bits CMD1 to CMD0 in the TRDFCR register are set to 10b (complementary PWM mode, buffer data transferred at underflow in the TRD1 register), the content in the buffer registers (TRDGRD0, TRDGRC1, and TRDGRD1) is transferred to the general registers (TRDGRB0, TRDGRA1, and TRDGRB1). During FFFFh, 0, 1 operation, data are not transferred to registers such as the TRDGRB0 register. Also, at this time, the OVF bit remains unchanged.

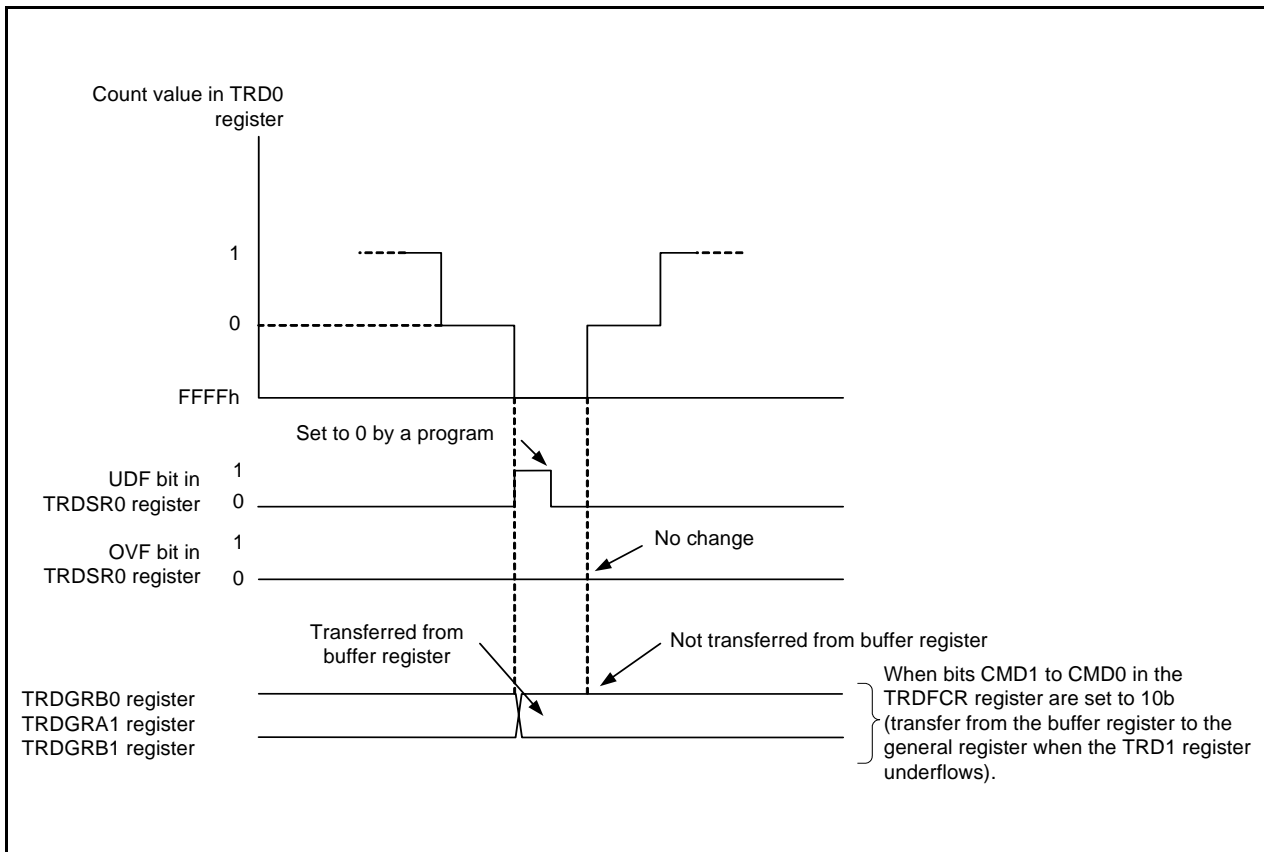

Figure 14.109 Operation when TRD1 Register Underflows in Complementary PWM Mode

- Select with bits CMD1 to CMD0 the timing of data transfer from the buffer register to the general register. However, transfer takes place with the following timing in spite of the value of bits CMD1 to CMD0 in the following cases:

Value in buffer register \geq value in TRDGRA0 register:

Transfer take place at underflow of the TRD1 register.

After this, when the buffer register is set to 0001h or above and a smaller value than the value of the TRDGRA0 register, and the TRD1 register underflows for the first time after setting, the value is transferred to the general register. After that, the value is transferred with the timing selected by bits CMD1 to CMD0.

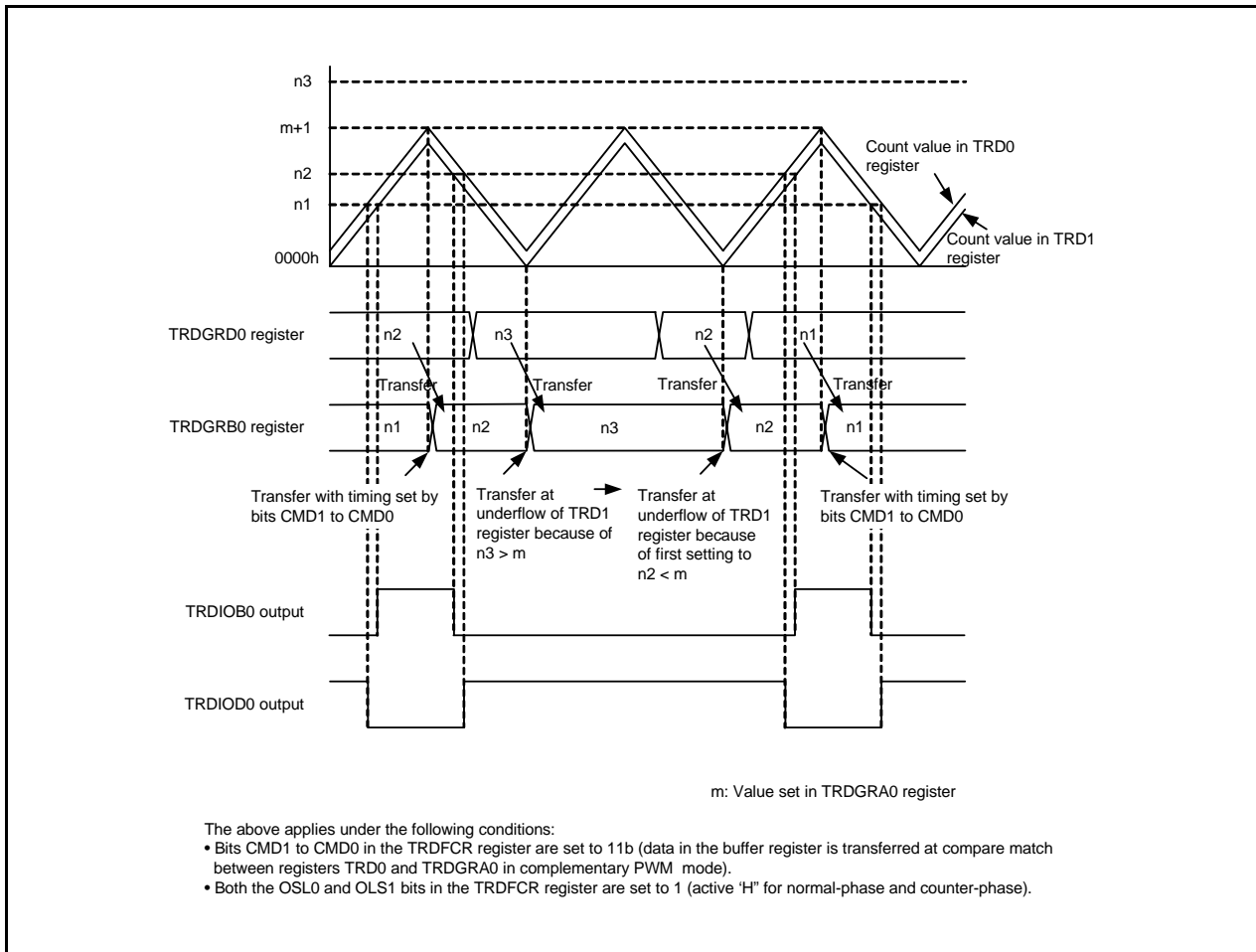

Figure 14.110 Operation when Value in Buffer Register \geq Value in TRDGRA0 Register in Complementary PWM Mode

When the value in the buffer register is set to 0000h:

Transfer takes place at compare match between registers TRD0 and TRDGRA0.

After this, when the buffer register is set to 0001h or above and a smaller value than the value of the TRDGRA0 register, and a compare match occurs between registers TRD0 and TRDGRA0 for the first time after setting, the value is transferred to the general register. After that, the value is transferred with the timing selected by bits CMD1 to CMD0.

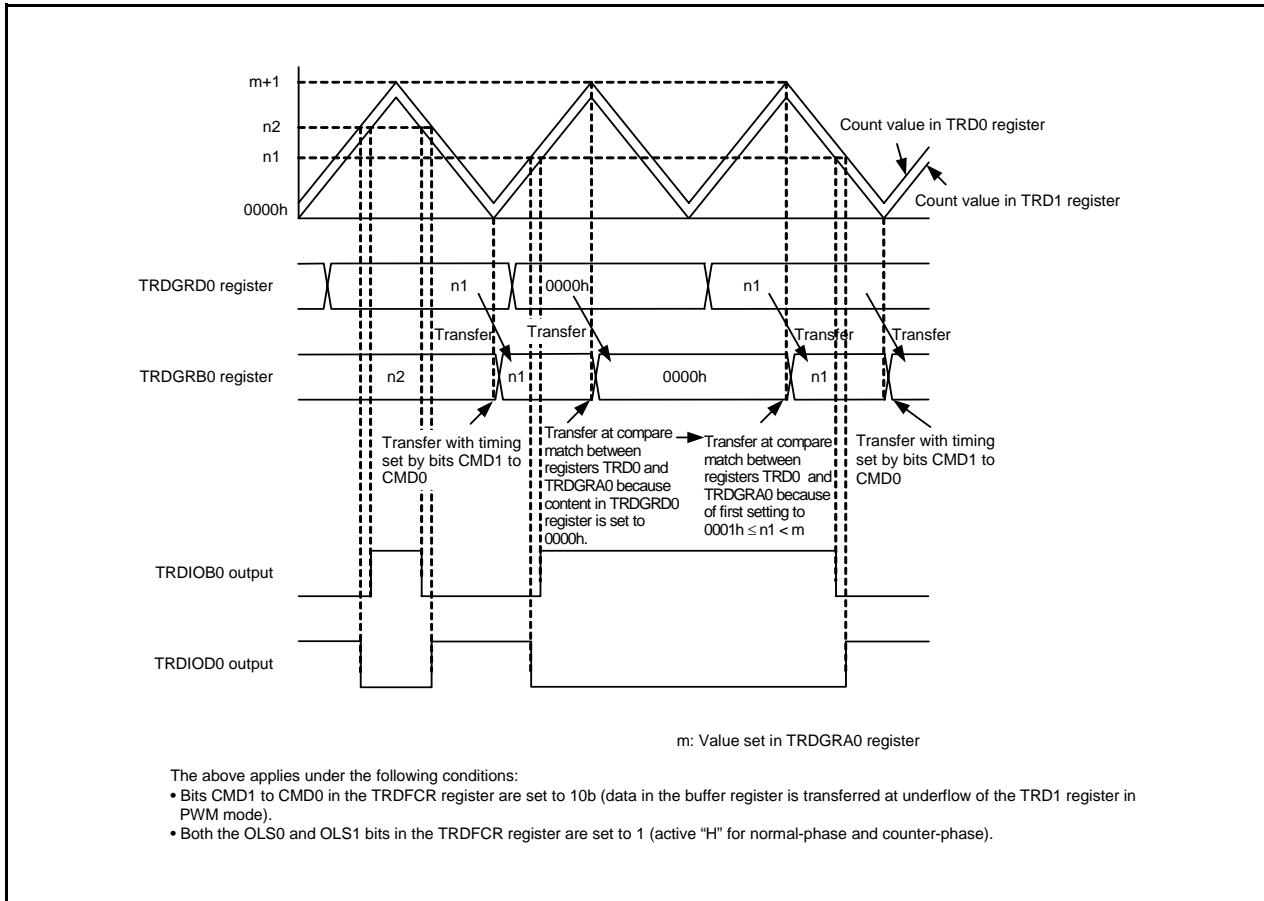

Figure 14.111 Operation when Value in Buffer Register Is Set to 0000h in Complementary PWM Mode

14.3.12.8 Count Source fOCO40M

- The count source fOCO40M can be used with supply voltage $V_{CC} = 3.0$ to 5.5 V. For supply voltage other than that, do not set bits TCK2 to TCK0 in registers TRDCR0 and TRDCR to 110b (select fOCO40M as the count source).

14.4 Timer RE

Timer RE has the 4-bit counter and 8-bit counter. Timer RE has the following 2 modes:

- Real-time clock mode Generate 1-second signal from fC4 and count seconds, minutes, hours, and days of the week.
- Output compare mode Count a count source and detect compare matches.

The count source for timer RE is the operating clock that regulates the timing of timer operations.

14.4.1 Real-Time Clock Mode

In real-time clock mode, a 1-second signal is generated from fC4 using a divide-by-2 frequency divider, 4-bit counter, and 8-bit counter and used to count seconds, minutes, hours, and days of the week. Figure 14.112 shows a Block Diagram of Real-Time Clock Mode and Table 14.37 lists the Real-Time Clock Mode Specifications. Figures 14.113 to 14.117 and 14.119 to 14.120 show the Registers Associated with Real-Time Clock Mode. Table 14.38 lists the Interrupt Sources, Figure 14.118 shows the Definition of Time Representation and Figure 14.121 shows the Operating Example in Real-Time Clock Mode.

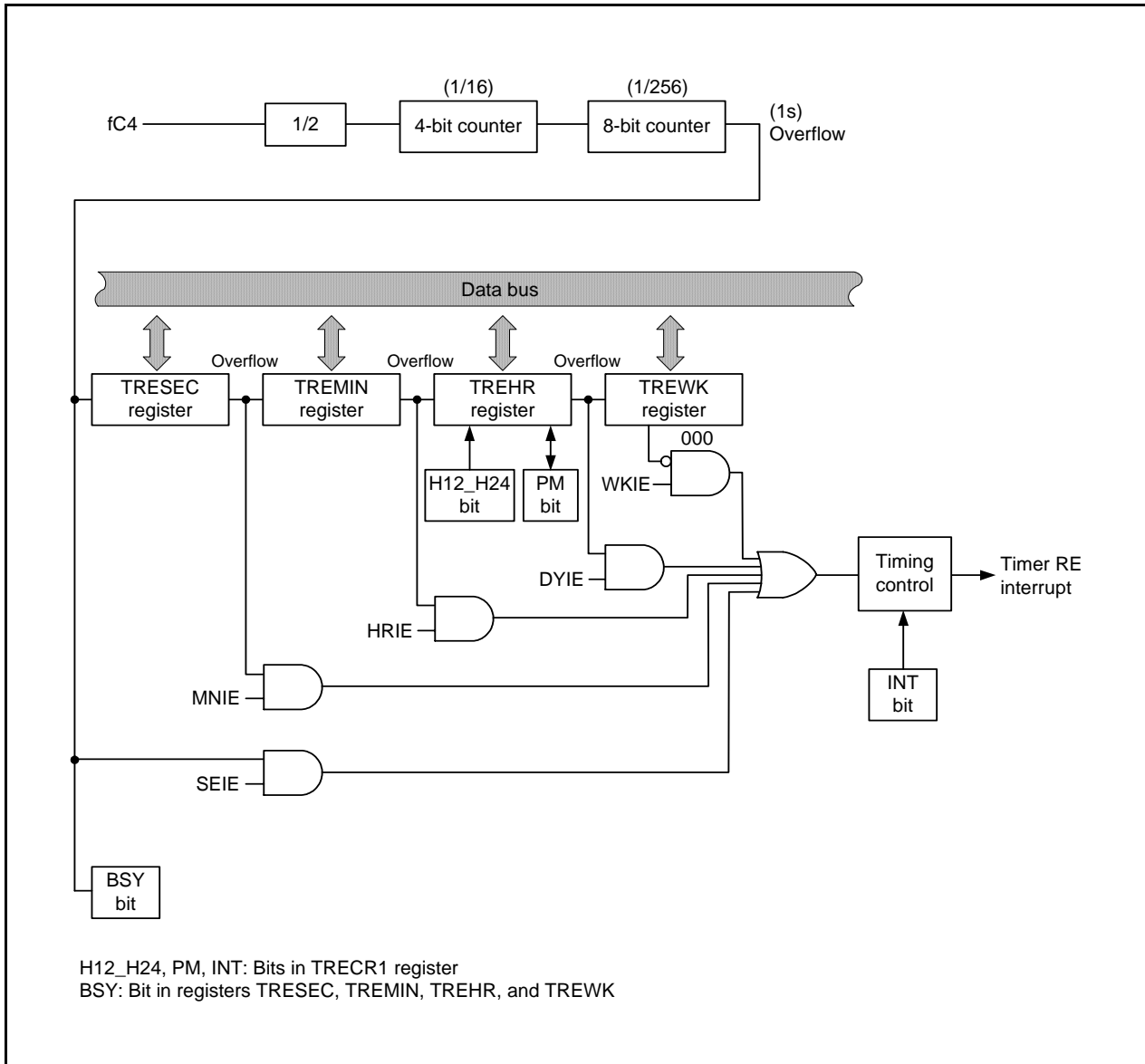

Figure 14.112 Block Diagram of Real-Time Clock Mode

Table 14.37 Real-Time Clock Mode Specifications

Item	Specification
Count source	fC4
Count operation	Increment
Count start condition	1 (count starts) is written to TSTART bit in TRECR1 register
Count stop condition	0 (count stops) is written to TSTART bit in TRECR1 register
Interrupt request generation timing	Select any one of the following: <ul style="list-style-type: none"> • Update second data • Update minute data • Update hour data • Update day of week data • When day of week data is set to 000b (Sunday)
TREO pin function	Programmable I/O ports or output of f2, f4, or f8
Read from timer	When reading TRESEC, TREMIN, TREHR, or TREWK register, the count value can be read. The values read from registers TRESEC, TREMIN, and TREHR are represented by the BCD code.
Write to timer	When bits TSTART and TCSTF in the TRECR1 register are set to 0 (timer stops), the value can be written to registers TRESEC, TREMIN, TREHR, and TREWK. The values written to registers TRESEC, TREMIN, and TREHR are represented by the BCD codes.
Select function	<ul style="list-style-type: none"> • 12-hour mode/24-hour mode switch function

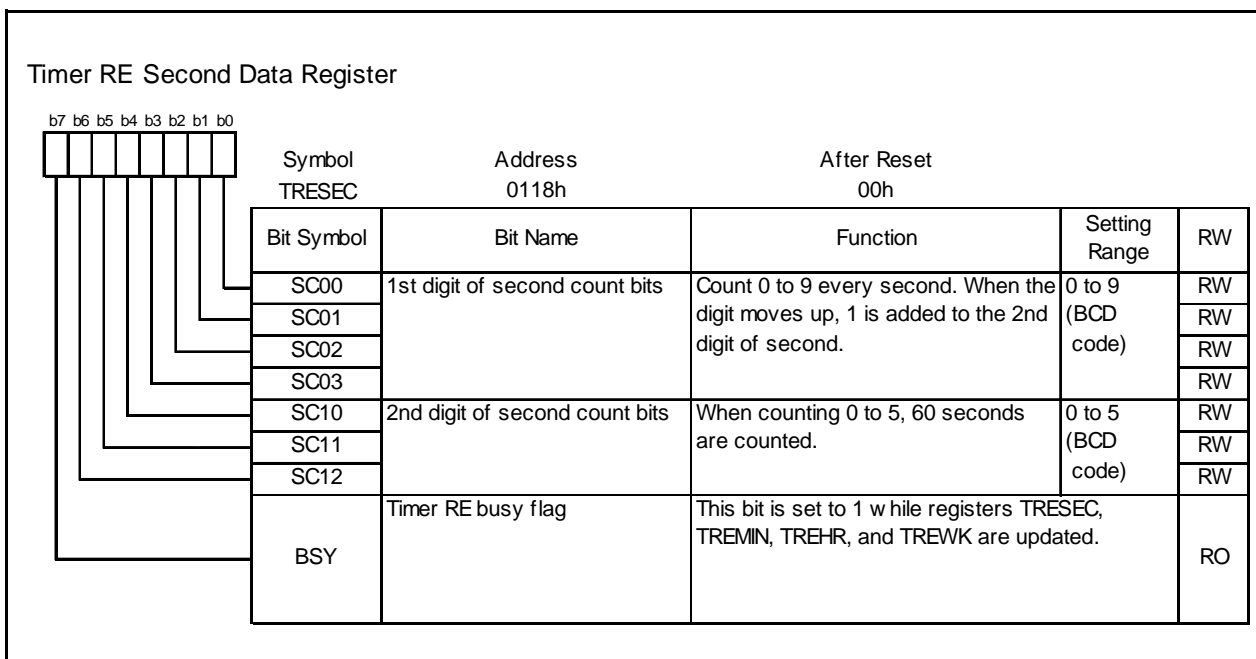

Figure 14.113 TRESEC Register in Real-Time Clock Mode

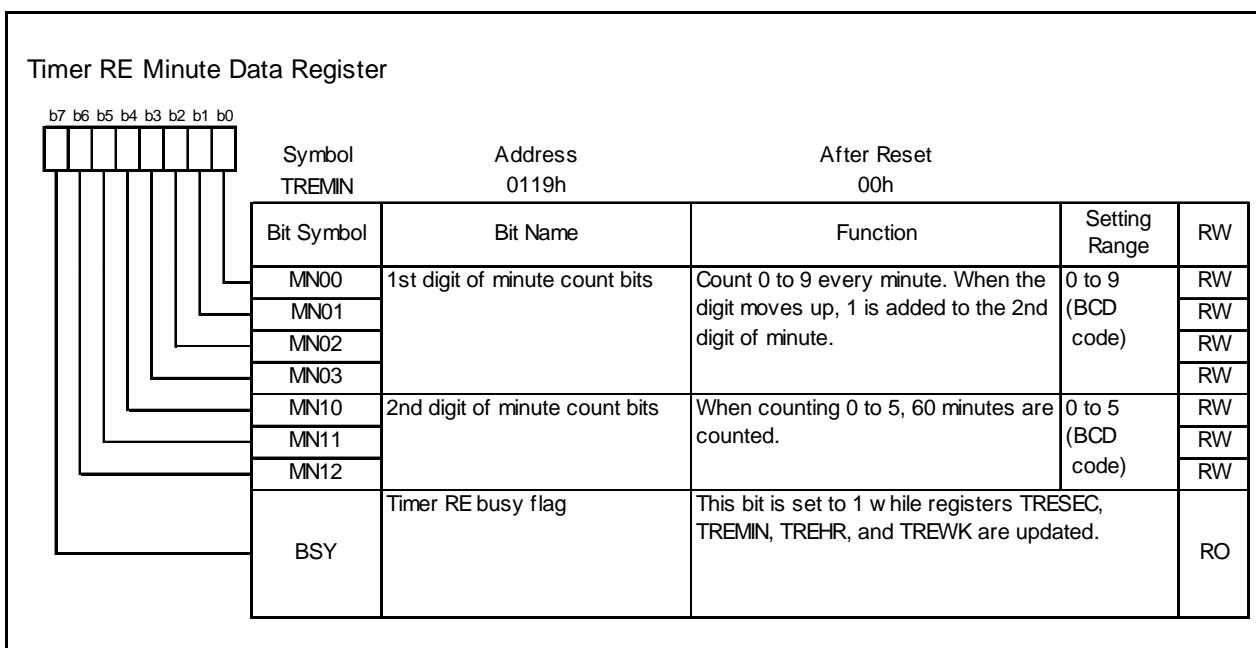

Figure 14.114 TREMIN Register in Real-Time Clock Mode

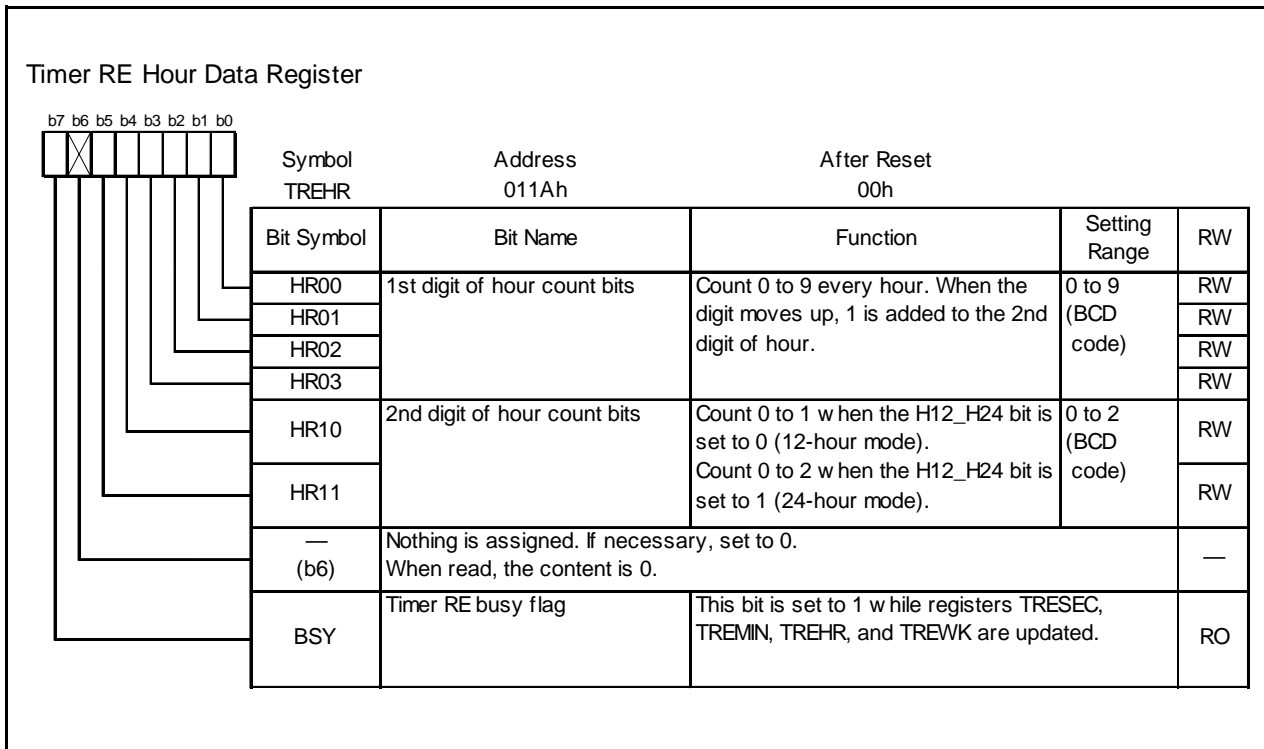

Figure 14.115 TREHR Register in Real-Time Clock Mode

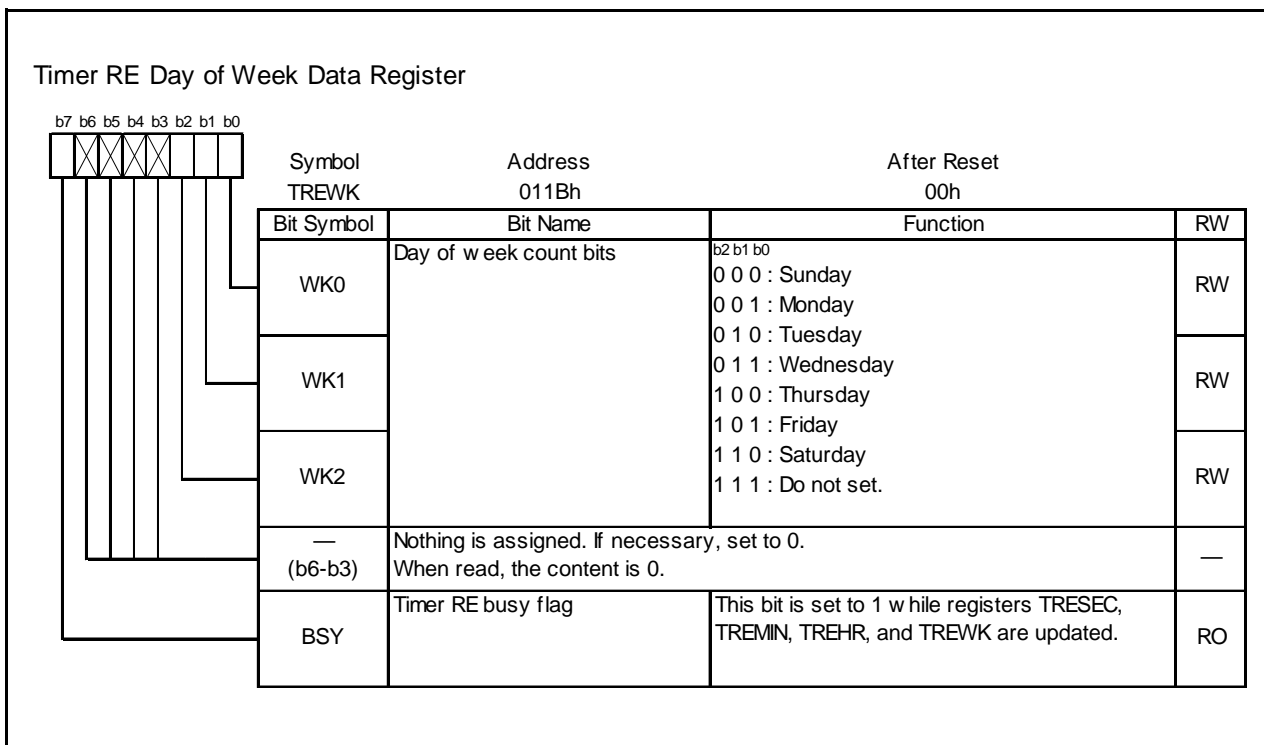

Figure 14.116 TREWK Register in Real-Time Clock Mode

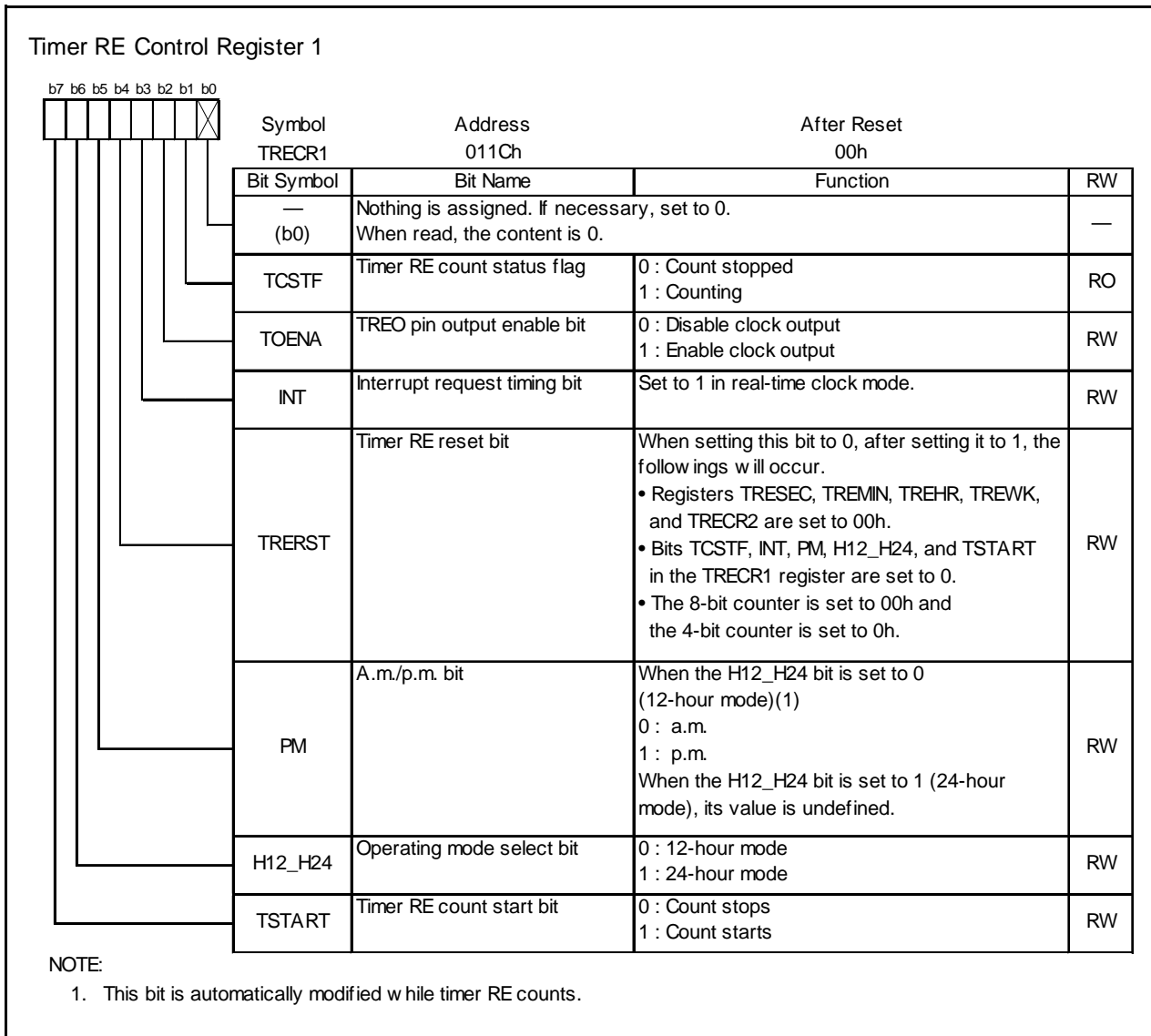

Figure 14.117 TRECR1 Register in Real-Time Clock Mode

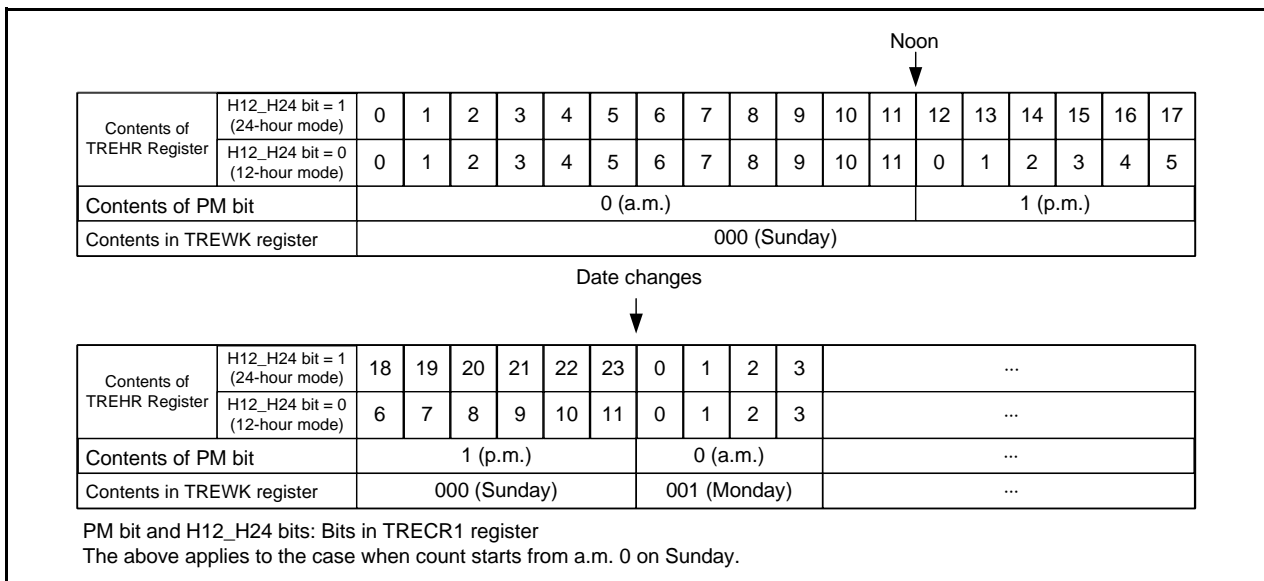

Figure 14.118 Definition of Time Representation

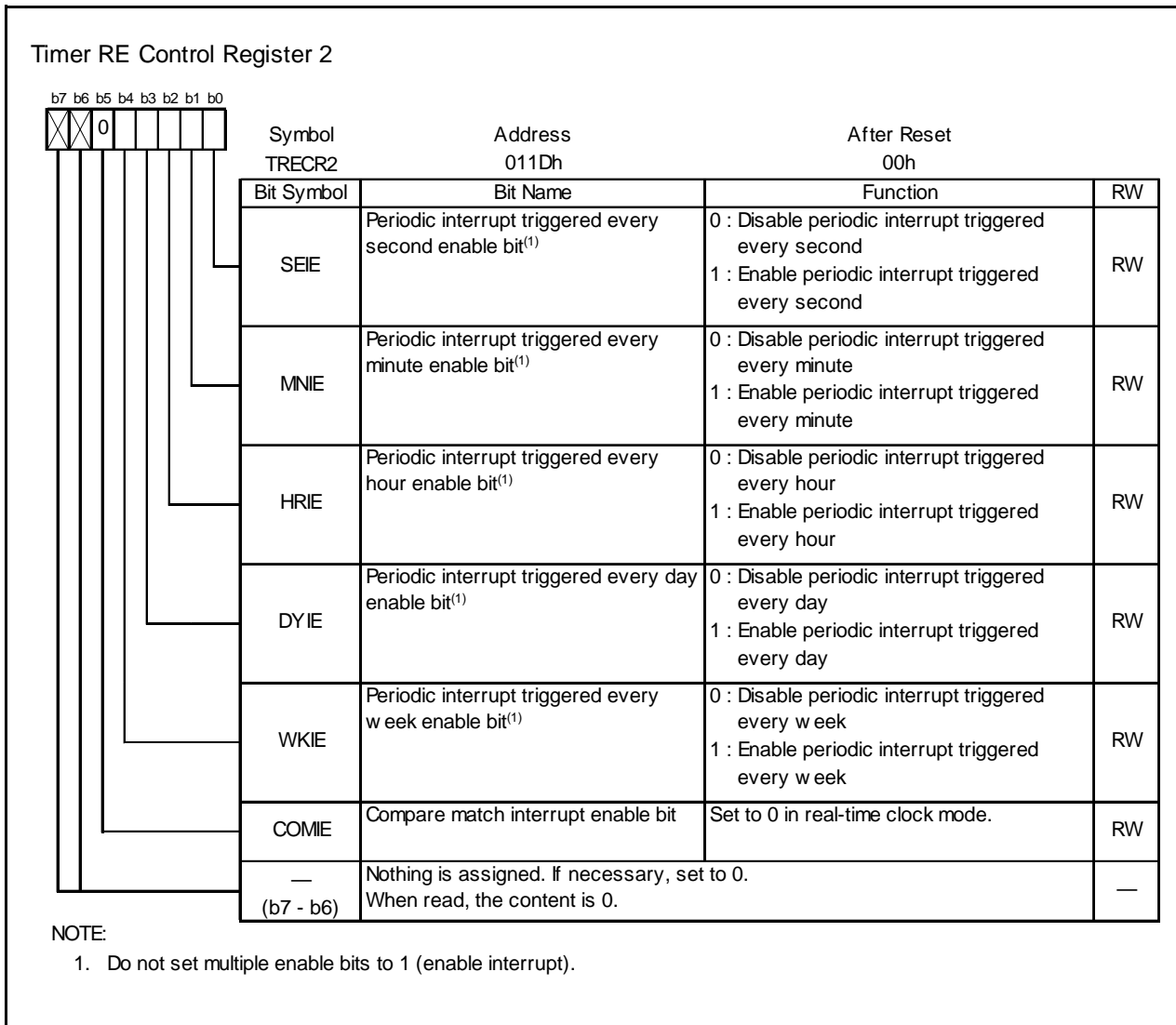

Figure 14.119 TRECR2 Register in Real-Time Clock Mode

Table 14.38 Interrupt Sources

Factor	Interrupt Source	Interrupt Enable Bit
Periodic interrupt triggered every week	Value in TREWK register is set to 000b (Sunday) (1-week period)	WKIE
Periodic interrupt triggered every day	TREWK register is updated (1-day period)	DYIE
Periodic interrupt triggered every hour	TREHR register is updated (1-hour period)	HRIE
Periodic interrupt triggered every minute	TREMIN register is updated (1-minute period)	MNIE
Periodic interrupt triggered every second	TRESEC register is updated (1-second period)	SEIE

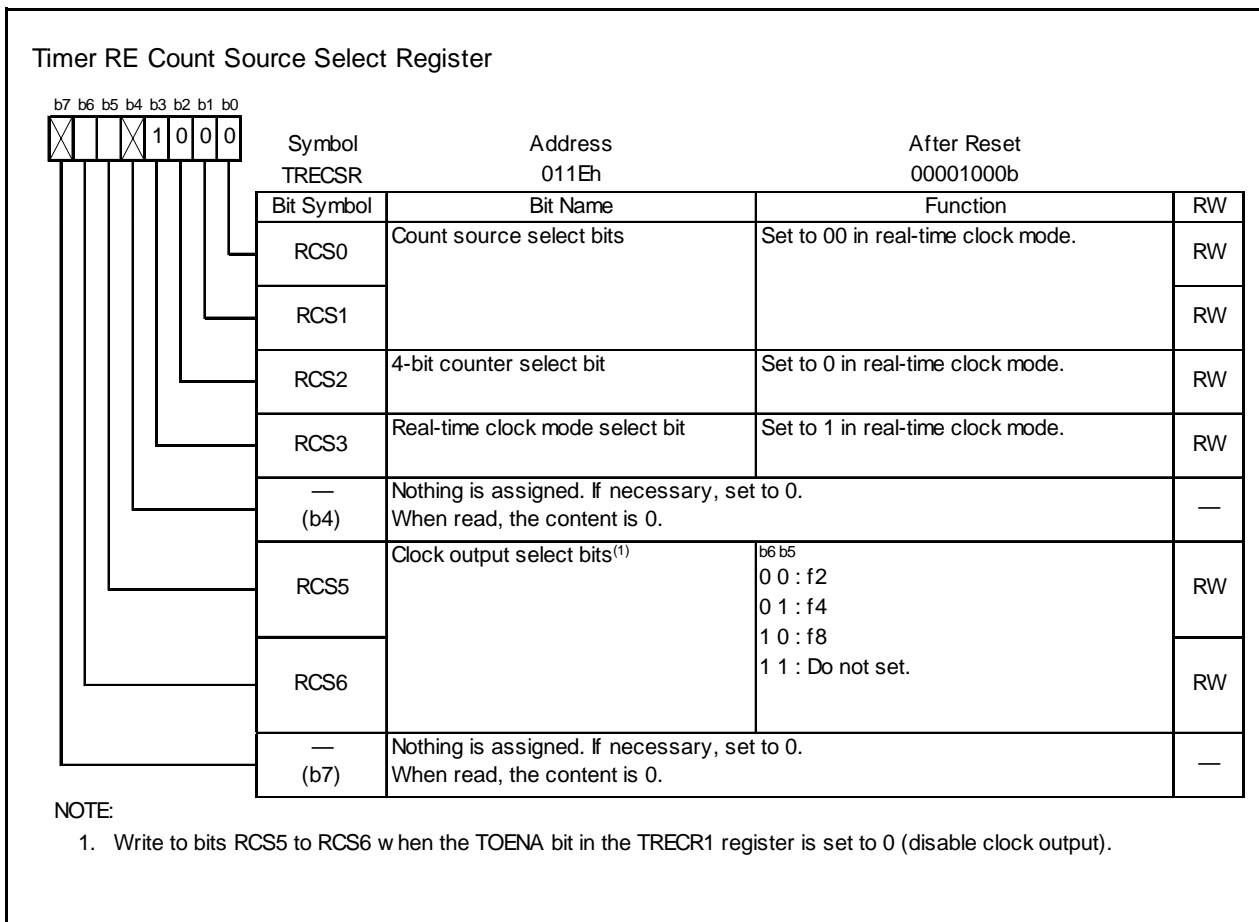

Figure 14.120 TRECSR Register in Real-Time Clock Mode

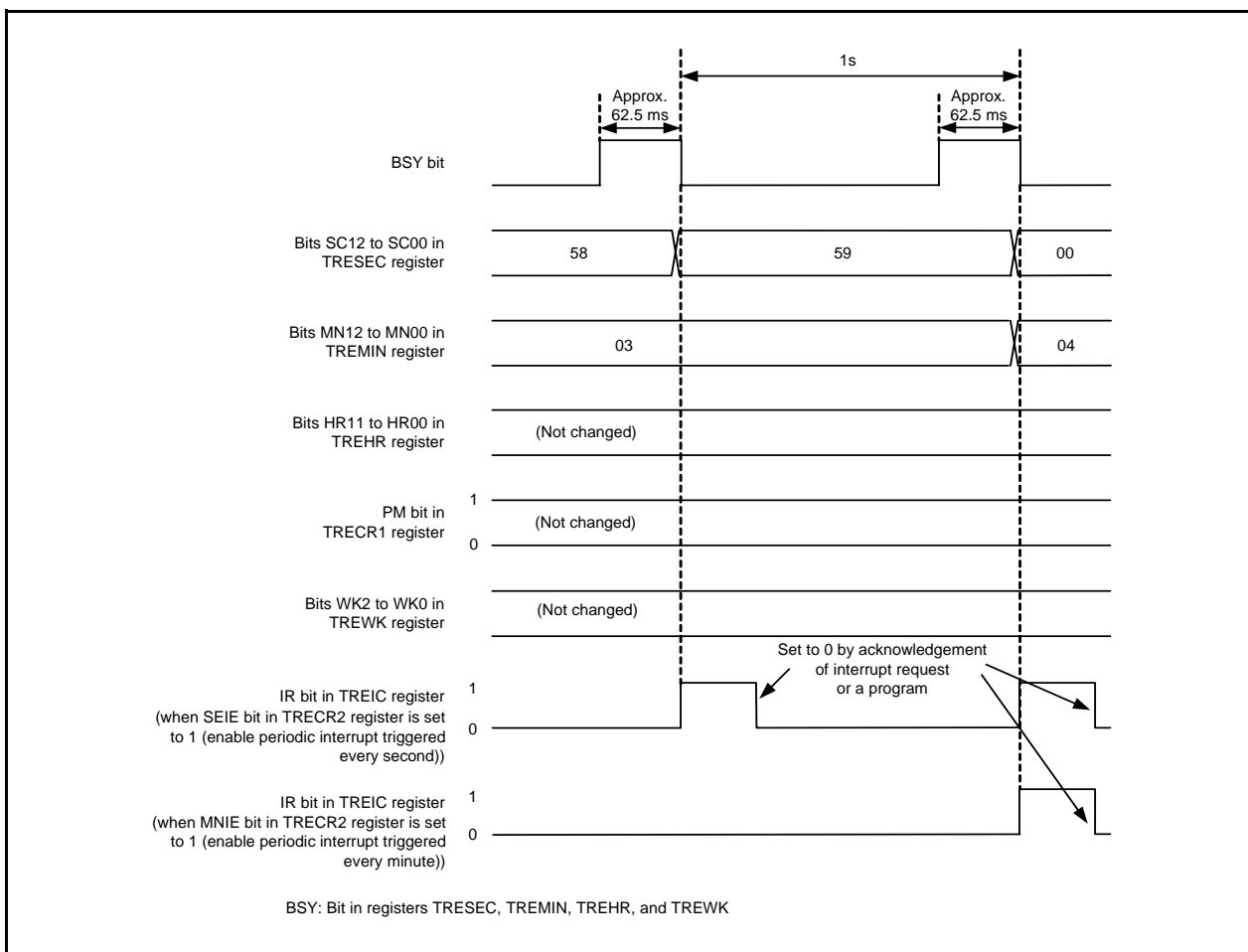

Figure 14.121 Operating Example in Real-Time Clock Mode

14.4.2 Output Compare Mode

In output compare mode, the internal count source divided by 2 is counted using the 4-bit or 8-bit counter and compare value match is detected with the 8-bit counter. Figure 14.122 shows a Block Diagram of Output Compare Mode and Table 14.39 lists the Output Compare Mode Specifications. Figures 14.123 to 14.127 show the Registers Associated with Output Compare Mode, and Figure 14.128 shows the Operating Example in Output Compare Mode.

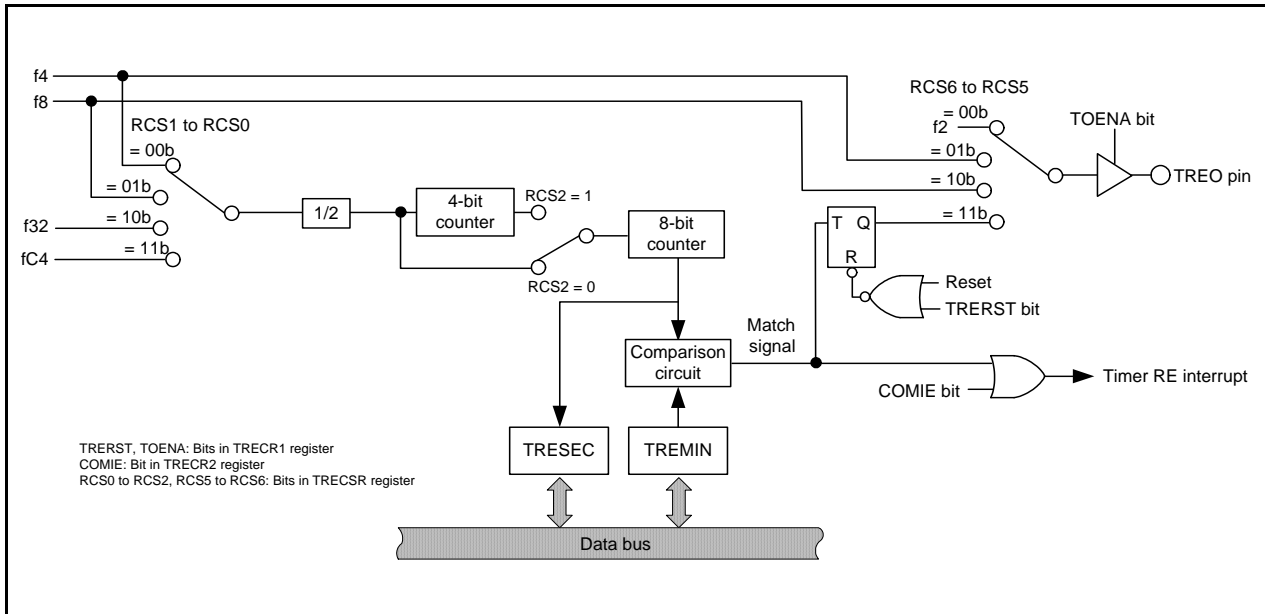

Figure 14.122 Block Diagram of Output Compare Mode

Table 14.39 Output Compare Mode Specifications

Item	Specification
Count sources	f4, f8, f32, fC4
Count operations	<ul style="list-style-type: none"> • Increment • When the 8-bit counter content matches with the TREMIN register content, the value returns to 00h and count continues. The count value is held while count stops.
Count period	<ul style="list-style-type: none"> • When RCS2 = 0 (4-bit counter is not used) $1/f_i \times 2 \times (n+1)$ • When RCS2 = 1 (4-bit counter is used) $1/f_i \times 32 \times (n+1)$ f _i : Frequency of count source n: Setting value of TREMIN register
Count start condition	1 (count starts) is written to the TSTART bit in the TRECR1 register
Count stop condition	0 (count stops) is written to the TSTART bit in the TRECR1 register
Interrupt request generation timing	When the 8-bit counter content matches with the TREMIN register content
TREO pin function	Select any one of the following: <ul style="list-style-type: none"> • Programmable I/O ports • Output f2, f4, or f8 • Compare output
Read from timer	When reading the TRESEC register, the 8-bit counter value can be read. When reading the TREMIN register, the compare value can be read.
Write to timer	Writing to the TRESEC register is disabled. When bits TSTART and TCSTF in the TRECR1 register are set to 0 (timer stops), writing to the TREMIN register is enabled.
Select functions	<ul style="list-style-type: none"> • Select use of 4-bit counter • Compare output function Every time the 8-bit counter value matches the TREMIN register value, TREO output polarity is reversed. The TREO pin outputs "L" after reset is deasserted and the timer RE is reset by the TRERST bit in the TRECR1 register. Output level is held by setting the TSTART bit to 0 (count stops).

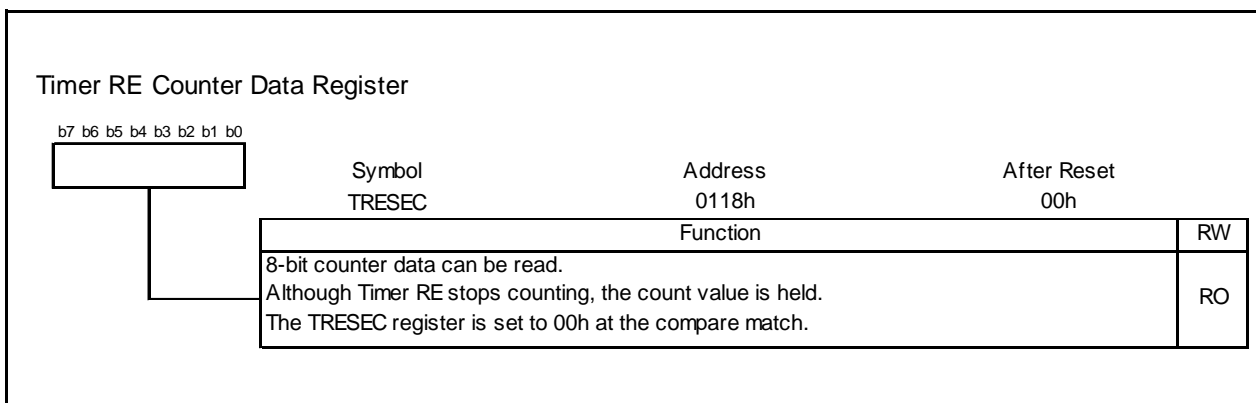

Figure 14.123 TRESEC Register in Output Compare Mode

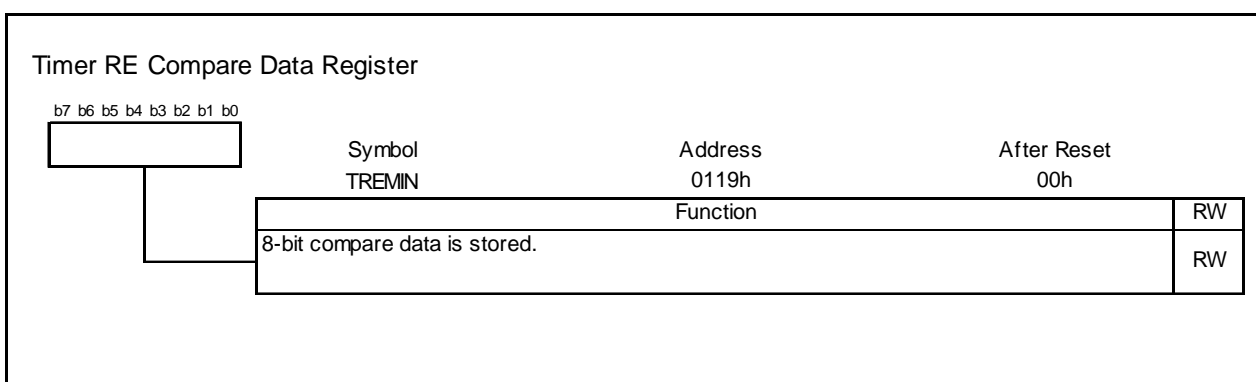

Figure 14.124 TREMIN Register in Output Compare Mode

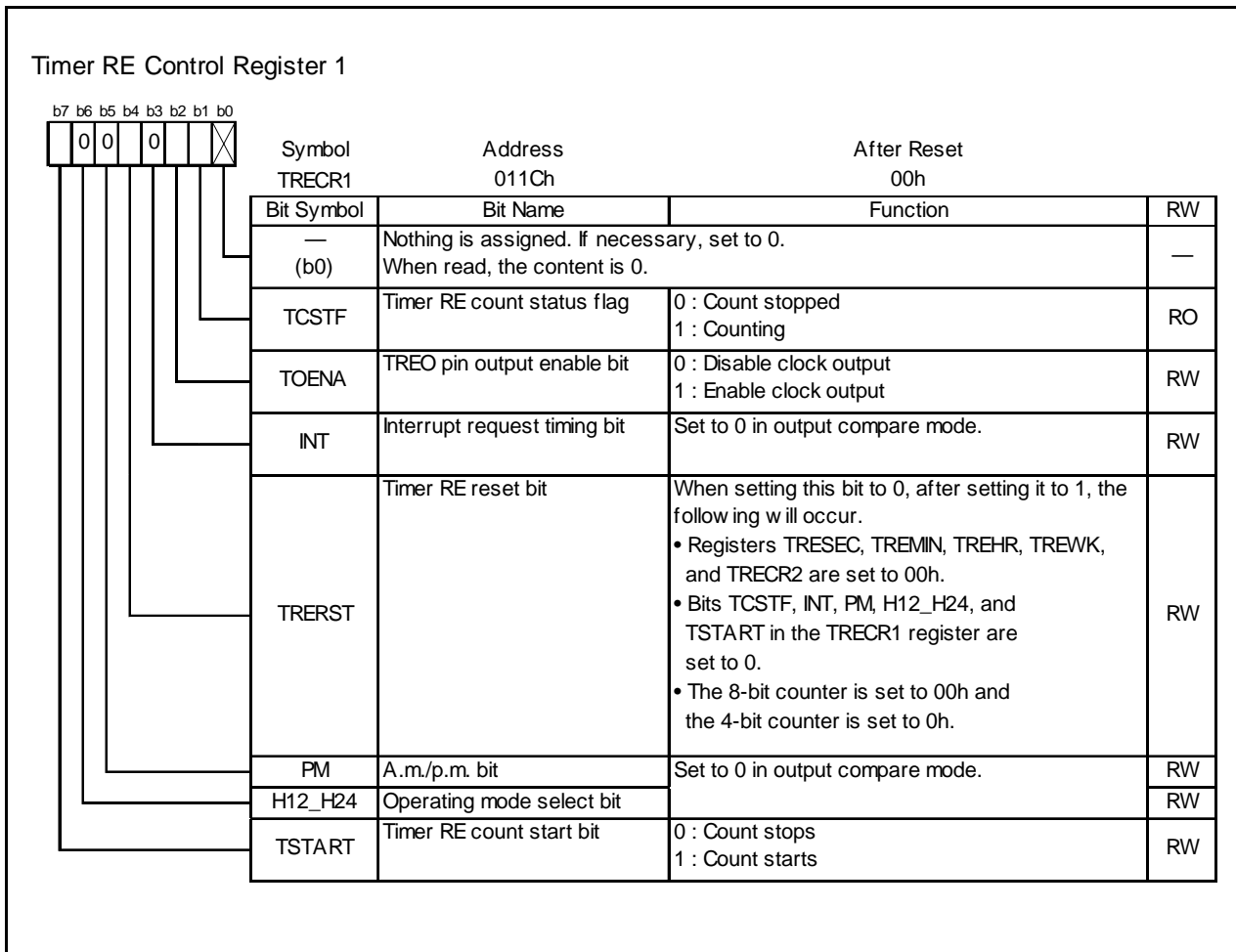

Figure 14.125 TREC1 Register in Output Compare Mode

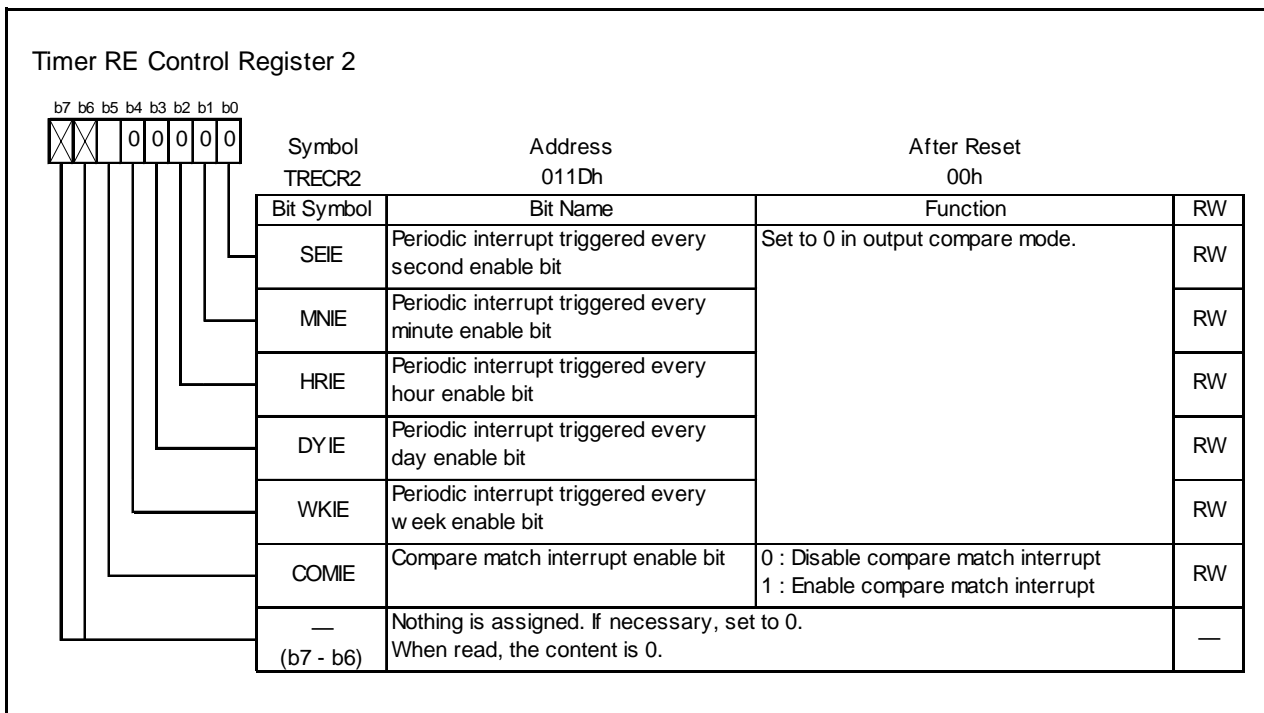

Figure 14.126 TREC2 Register in Output Compare Mode

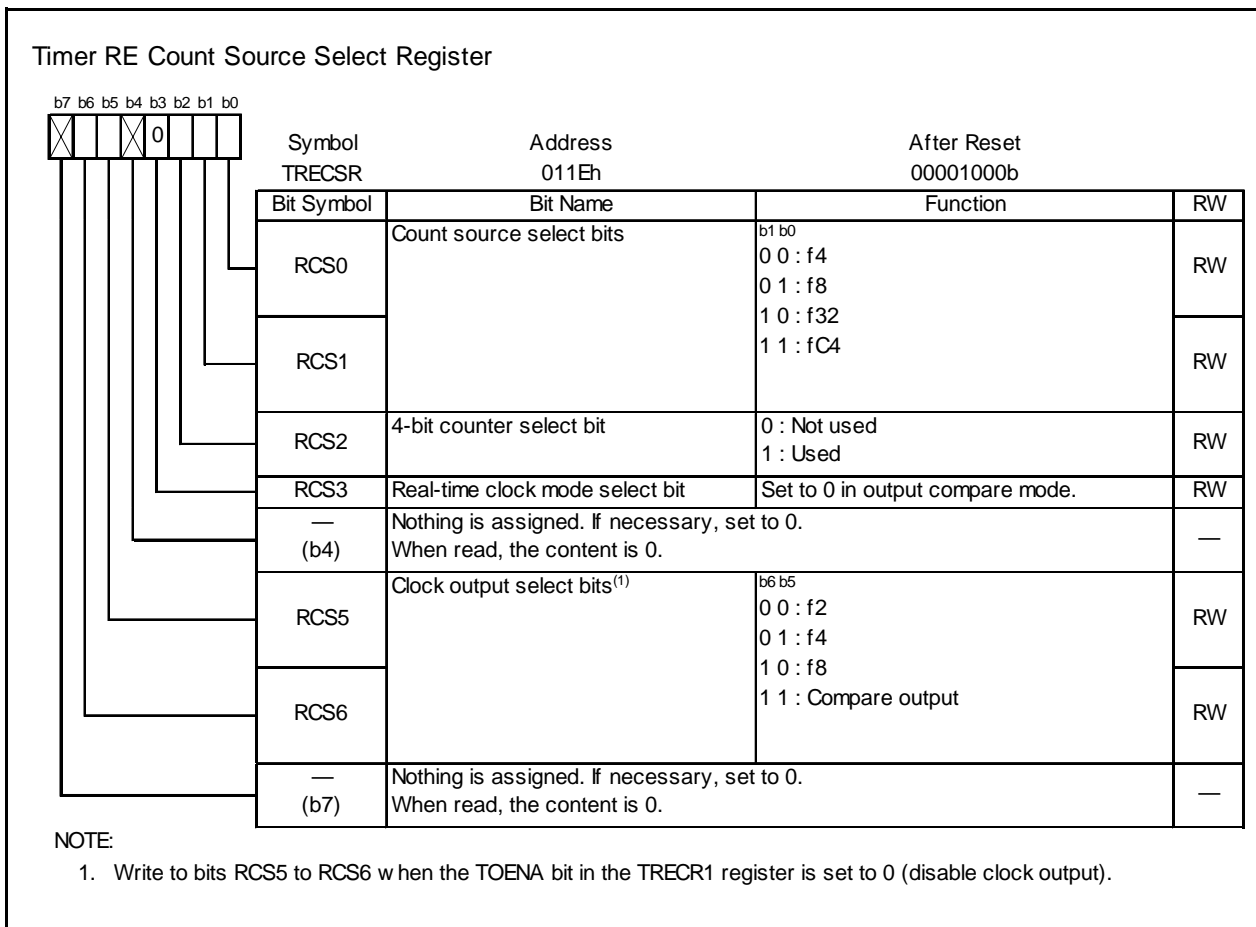

Figure 14.127 TRECSR Register in Output Compare Mode

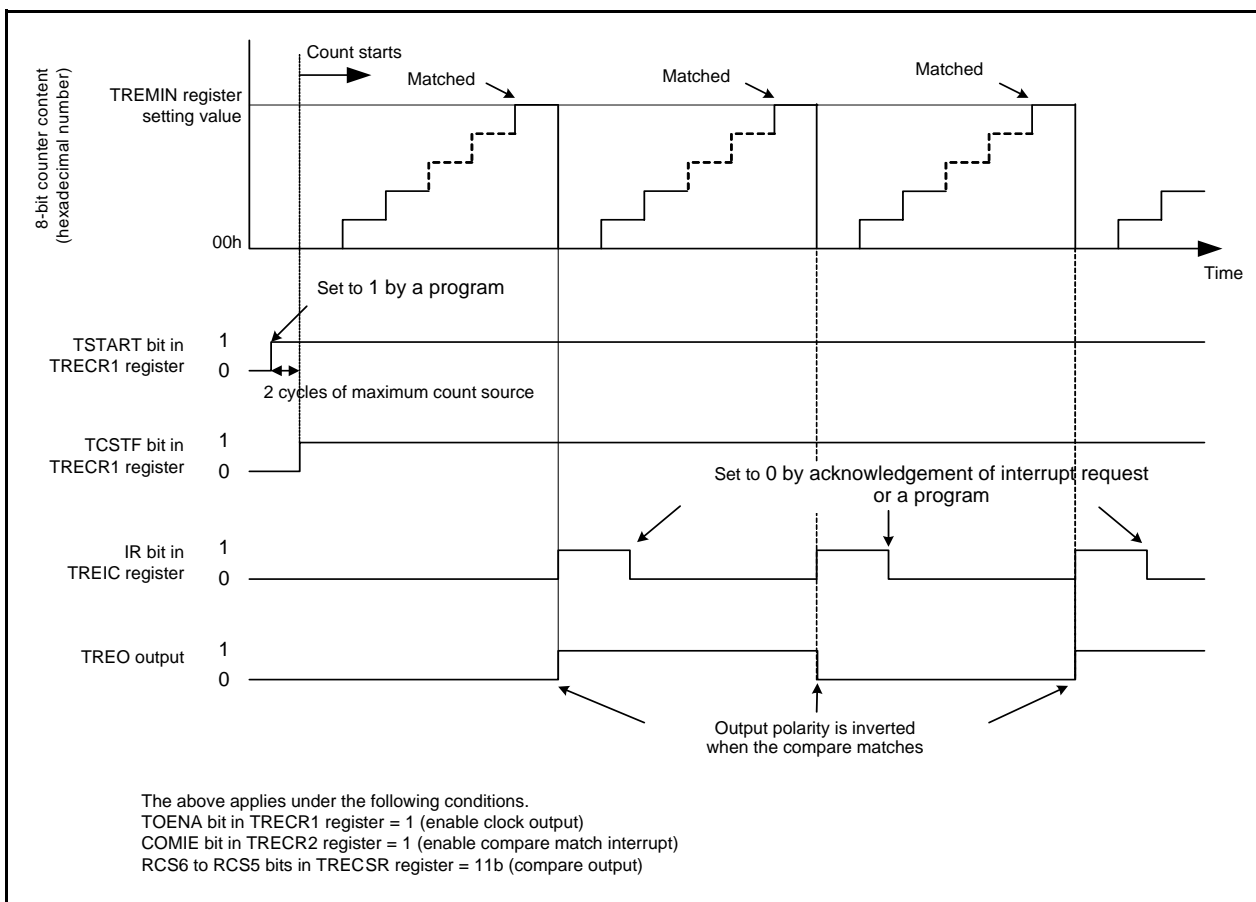

Figure 14.128 Operating Example in Output Compare Mode

14.4.3 Notes on Timer RE

14.4.3.1 Starting and Stopping Count

Timer RE has the TSTART bit for instructing the count to start or stop, and the TCSTF bit, which indicates count start or stop. Bits TSTART and TCSTF are in the TRECRC1 register.

Timer RE starts counting and the TCSTF bit is set to 1 (count starts) when the TSTART bit is set to 1 (count starts). It takes up to 2 cycles of the count source until the TCSTF bit is set to 1 after setting the TSTART bit to 1. During this time, do not access registers associated with timer RE⁽¹⁾ other than the TCSTF bit.

Also, timer RE stops counting when setting the TSTART bit to 0 (count stops) and the TCSTF bit is set to 0 (count stops). It takes the time for up to 2 cycles of the count source until the TCSTF bit is set to 0 after setting the TSTART bit to 0. During this time, do not access registers associated with timer RE other than the TCSTF bit.

NOTE:

1. Registers associated with timer RE: TRESEC, TREMIN, TREHR, TREWK, TRECRC1, TRECRC2, and TRECSR.

14.4.3.2 Register Setting

Write to the following registers or bits when timer RE is stopped.

- Registers TRESEC, TREMIN, TREHR, TREWK, and TRECRC2
- Bits H12_H24, PM, and INT in TRECRC1 register
- Bits RCS0 to RCS3 in TRECSR register

Timer RE is stopped when bits TSTART and TCSTF in the TRECRC1 register are set to 0 (timer RE stopped).

Also, set all above-mentioned registers and bits (immediately before timer RE count starts) before setting the TRECRC2 register.

Figure 14.129 shows a Setting Example in Real-Time Clock Mode.

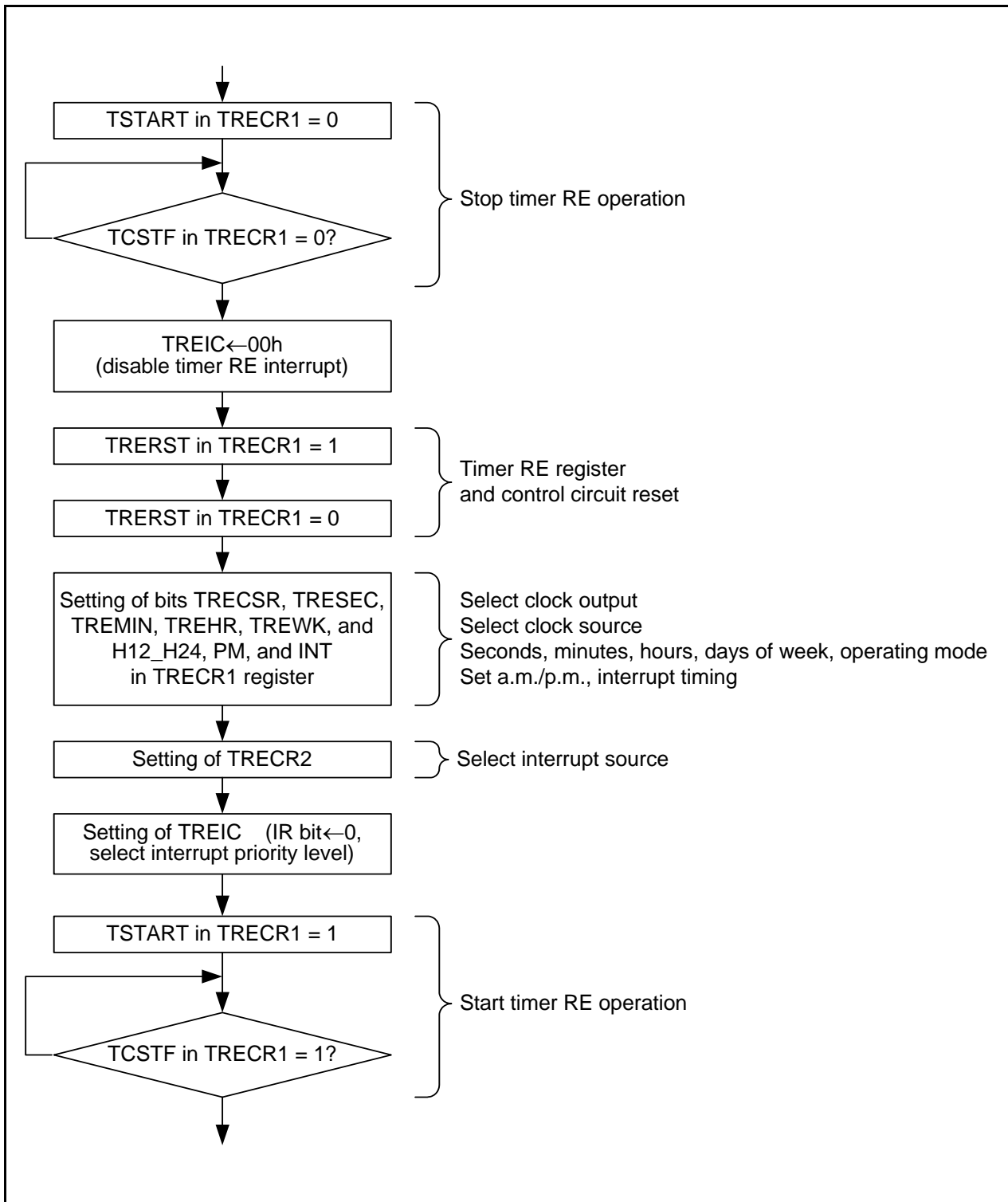

Figure 14.129 Setting Example in Real-Time Clock Mode

14.4.3.3 Time Reading Procedure of Real-Time Clock Mode

In real-time clock mode, read registers TRESEC, TREMIN, TREHR, and TREWK when time data is updated and read the PM bit in the TRECR1 register when the BSY bit is set to 0 (not while data is updated).

Also, when reading several registers, an incorrect time will be read if data is updated before another register is read after reading any register.

In order to prevent this, use the reading procedure shown below.

- Using an interrupt
Read necessary contents of registers TRESEC, TREMIN, TREHR, and TREWK and the PM bit in the TRECR1 register in the timer RE interrupt routine.
- Monitoring with a program 1
Monitor the IR bit in the TREIC register with a program and read necessary contents of registers TRESEC, TREMIN, TREHR, and TREWK and the PM bit in the TRECR1 register after the IR bit in the TREIC register is set to 1 (timer RE interrupt request generated).
- Monitoring with a program 2
 - (1) Monitor the BSY bit.
 - (2) Monitor until the BSY bit is set to 0 after the BSY bit is set to 1 (approximately 62.5 ms while the BSY bit is set to 1).
 - (3) Read necessary contents of registers TRESEC, TREMIN, TREHR, and TREWK and the PM bit in the TRECR1 register after the BSY bit is set to 0.
- Using read results if they are the same value twice
 - (1) Read necessary contents of registers TRESEC, TREMIN, TREHR, and TREWK and the PM bit in the TRECR1 register.
 - (2) Read the same register as (1) and compare the contents.
 - (3) Recognize as the correct value if the contents match. If the contents do not match, repeat until the read contents match with the previous contents.

Also, when reading several registers, read them as continuously as possible.

15. Serial Interface

The serial interface consists of two channels (UART0 and UART1). Each UART_i (i = 0 or 1) has an exclusive timer to generate the transfer clock and operates independently.

Figure 15.1 shows a UART_i (i = 0 or 1) Block Diagram. Figure 15.2 shows a UART_i Transmit/Receive Unit.

UART_i has two modes: clock synchronous serial I/O mode and clock asynchronous serial I/O mode (UART mode). Figures 15.3 to 15.6 show the Registers Associated with UART_i.

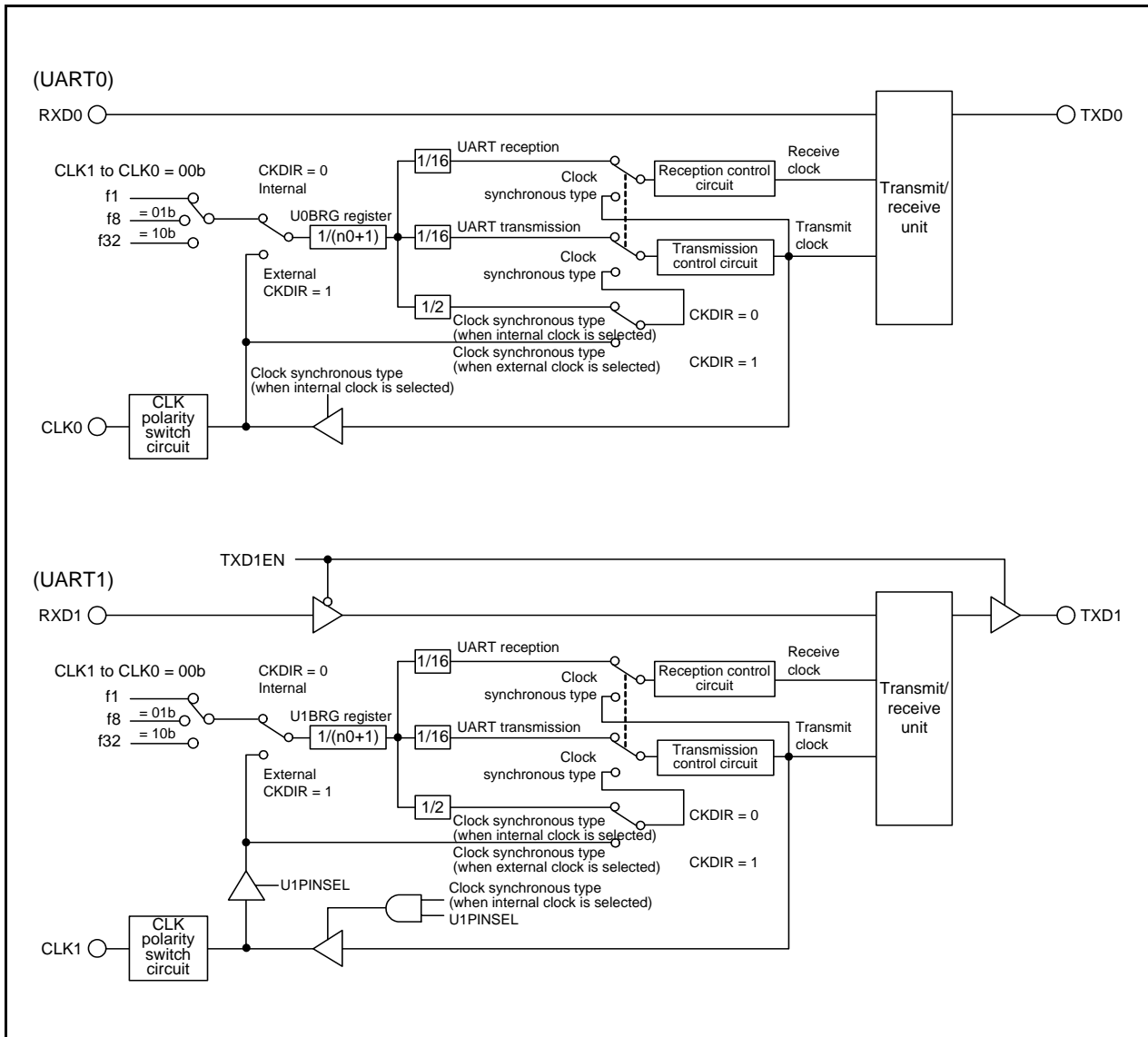

Figure 15.1 UART_i (i = 0 or 1) Block Diagram

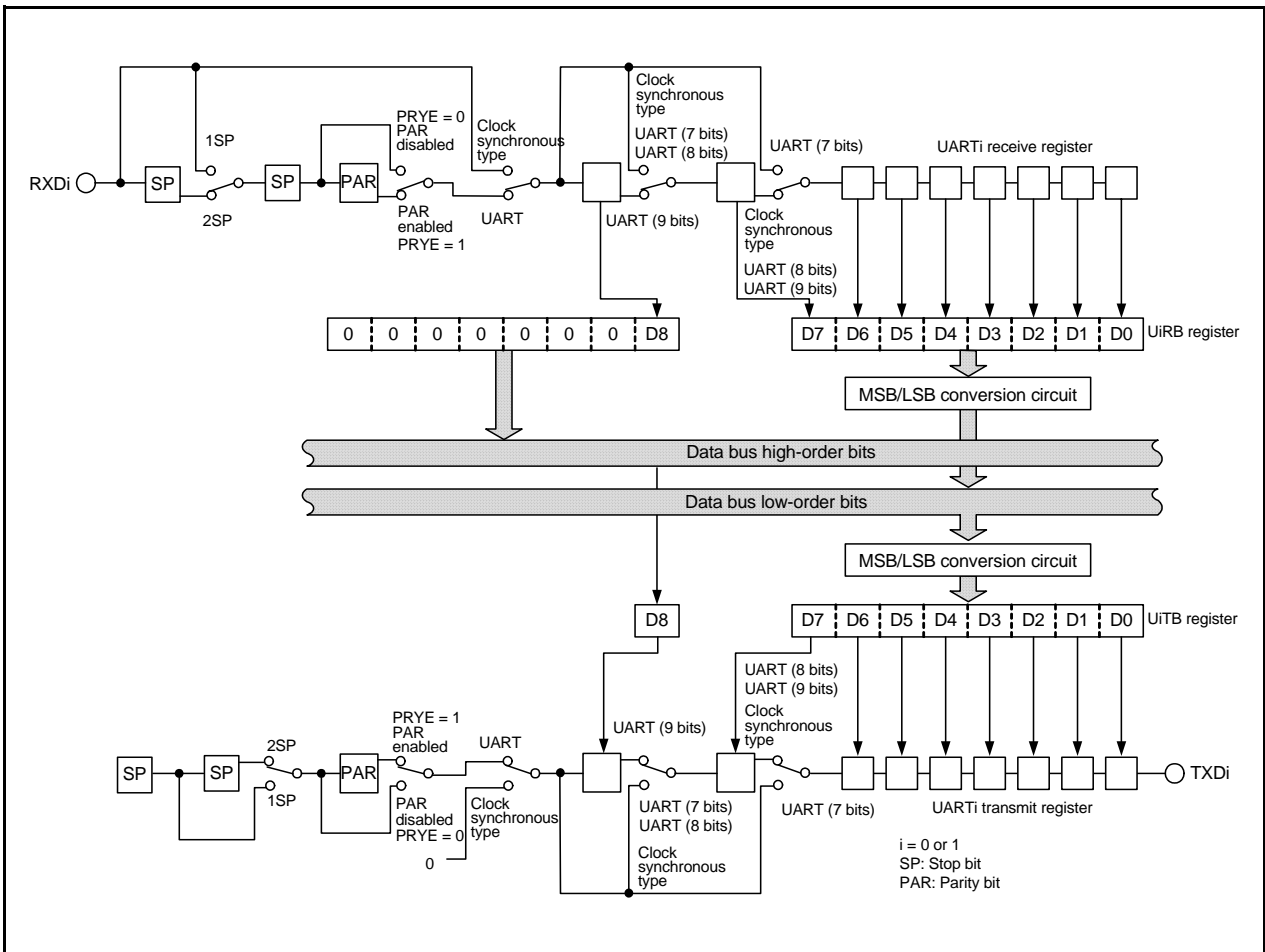

Figure 15.2 UARTi Transmit/Receive Unit

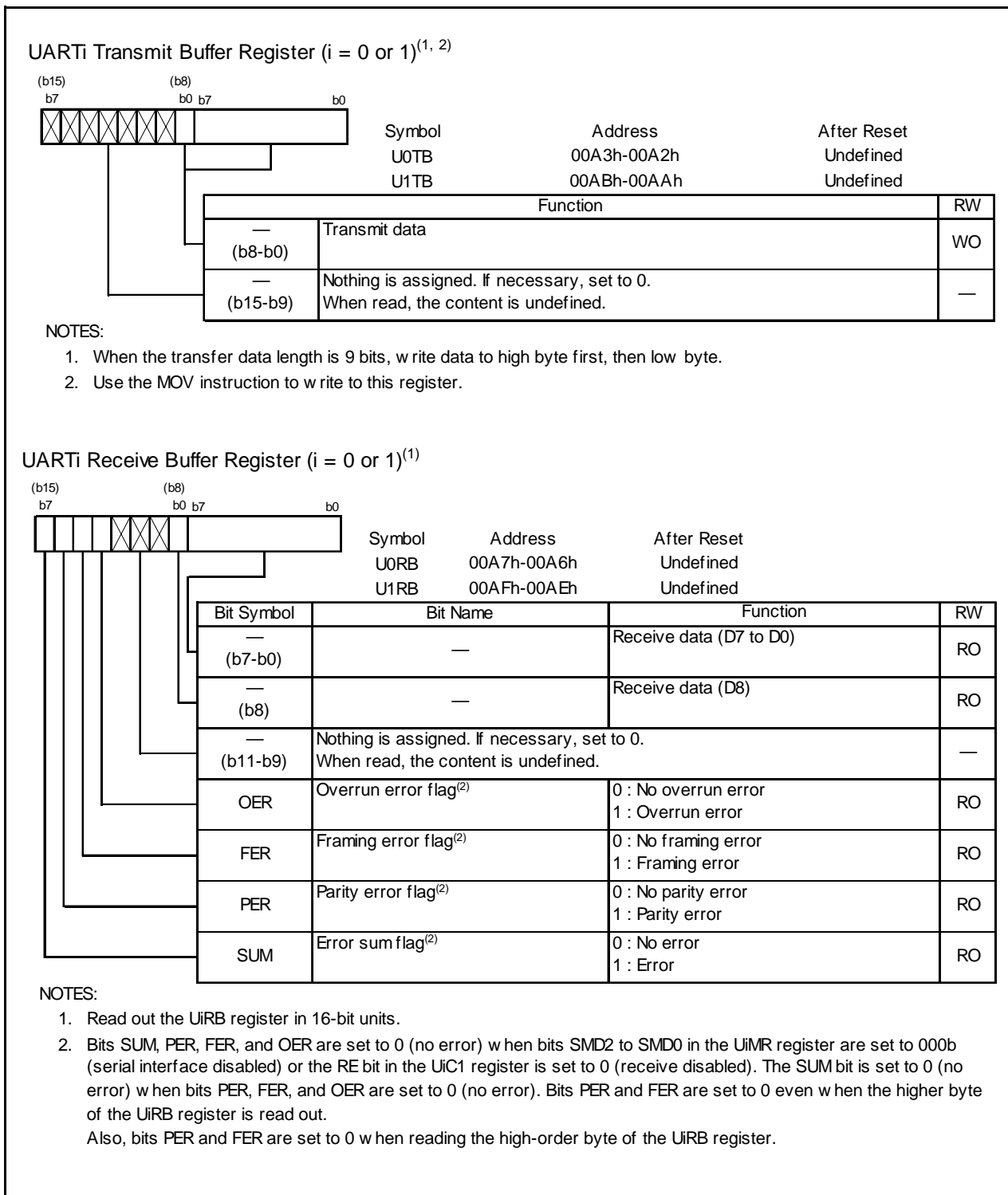

Figure 15.3 Registers U0TB to U1TB and U0RB to U1RB

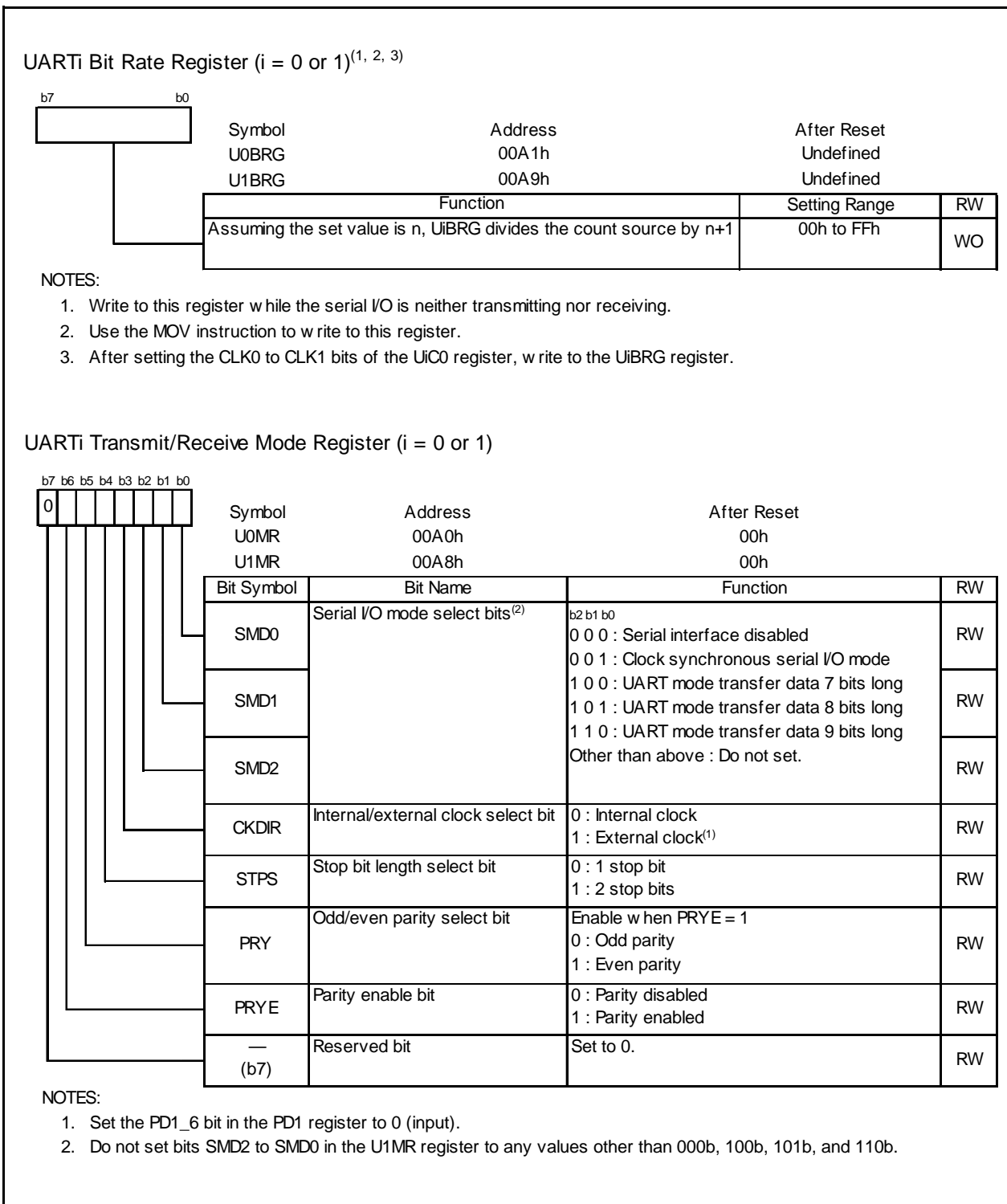

Figure 15.4 Registers U0BRG to U1BRG and U0MR to U1MR

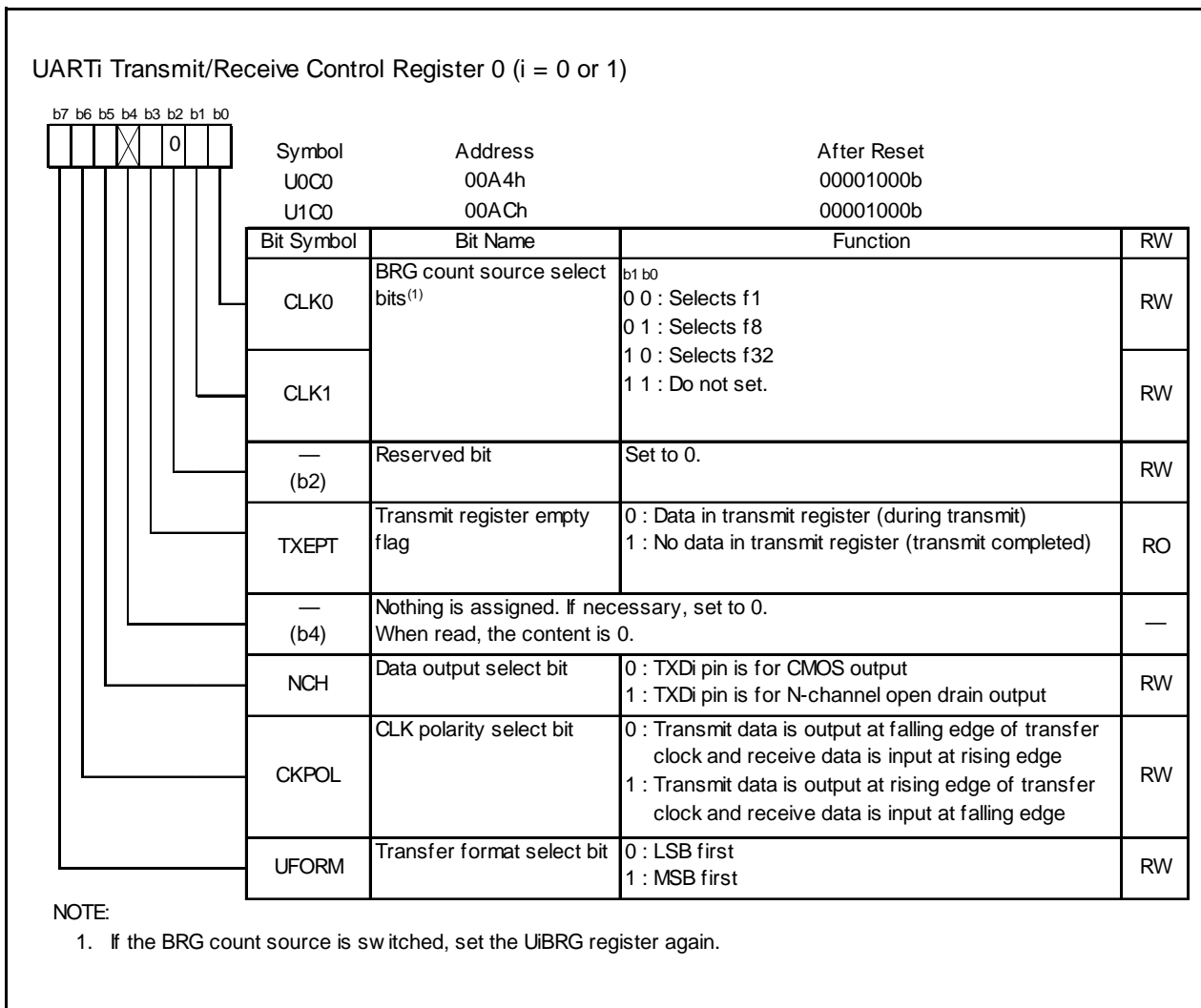

Figure 15.5 Registers U0C0 to U1C0

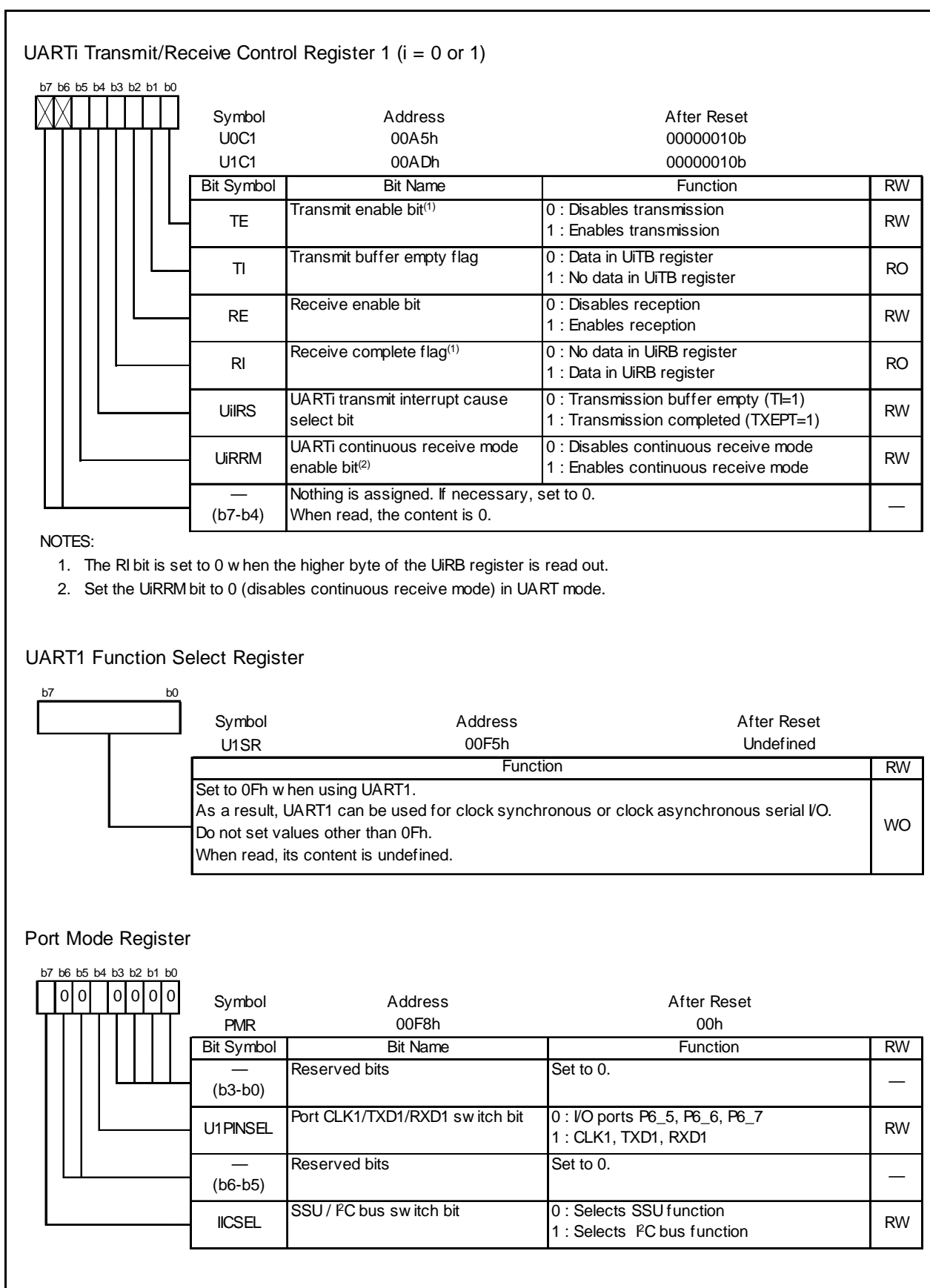

Figure 15.6 Registers U0C1 to U1C1, U1SR, and PMR

15.1 Clock Synchronous Serial I/O Mode

In clock synchronous serial I/O mode, data is transmitted and received using a transfer clock.

Table 15.1 lists the Clock Synchronous Serial I/O Mode Specifications. Table 15.2 lists the Registers Used and Settings in Clock Synchronous Serial I/O Mode⁽¹⁾.

Table 15.1 Clock Synchronous Serial I/O Mode Specifications

Item	Specification
Transfer data format	<ul style="list-style-type: none"> Transfer data length: 8 bits
Transfer clocks	<ul style="list-style-type: none"> CKDIR bit in UiMR register is set to 0 (internal clock): $f_i/(2(n+1))$ $f_i = f_1, f_8, f_{32}$ $n =$ value set in UiBRG register: 00h to FFh The CKDIR bit is set to 1 (external clock): input from CLKi pin
Transmit start conditions	<ul style="list-style-type: none"> Before transmission starts, the following requirements must be met⁽¹⁾ <ul style="list-style-type: none"> The TE bit in the UiC1 register is set to 1 (transmission enabled) The TI bit in the UiC1 register is set to 0 (data in the UiTB register)
Receive start conditions	<ul style="list-style-type: none"> Before reception starts, the following requirements must be met⁽¹⁾ <ul style="list-style-type: none"> The RE bit in the UiC1 register is set to 1 (reception enabled) The TE bit in the UiC1 register is set to 1 (transmission enabled) The TI bit in the UiC1 register is set to 0 (data in the UiTB register)
Interrupt request generation timing	<ul style="list-style-type: none"> When transmitting, one of the following conditions can be selected <ul style="list-style-type: none"> The UiIRS bit is set to 0 (transmit buffer empty): When transferring data from the UiTB register to UARTi transmit register (when transmission starts). The UiIRS bit is set to 1 (transmission completes): When completing data transmission from UARTi transmit register. When receiving When data transfer from the UARTi receive register to the UiRB register (when reception completes).
Error detection	<ul style="list-style-type: none"> Overrun error⁽²⁾ This error occurs if the serial interface starts receiving the next data item before reading the UiRB register and receives the 7th bit of the next data.
Select functions	<ul style="list-style-type: none"> CLK polarity selection Transfer data input/output can be selected to occur synchronously with the rising or the falling edge of the transfer clock. LSB first, MSB first selection Whether transmitting or receiving data begins with bit 0 or begins with bit 7 can be selected. Continuous receive mode selection Receive is enabled immediately by reading the UiRB register.

i = 0 or 1

NOTES:

- If an external clock is selected, ensure that the external clock is "H" when the CKPOL bit in the UiC0 register is set to 0 (transmit data output at falling edge and receive data input at rising edge of transfer clock), and that the external clock is "L" when the CKPOL bit is set to 1 (transmit data output at rising edge and receive data input at falling edge of transfer clock).
- If an overrun error occurs, the receive data (b0 to b8) of the UiRB register will be undefined. The IR bit in the SiRIC register remains unchanged.

Table 15.2 Registers Used and Settings in Clock Synchronous Serial I/O Mode⁽¹⁾

Register	Bit	Function
UiTB	0 to 7	Set data transmission
UiRB	0 to 7	Data reception can be read
	OER	Overflow error flag
UiBRG	0 to 7	Set bit rate
UiMR	SMD2 to SMD0	Set to 001b
	CKDIR	Select the internal clock or external clock
UiC0	CLK1 to CLK0	Select the count source in the UiBRG register
	TXEPT	Transmit register empty flag
	NCH	Select TXDi pin output mode
	CKPOL	Select the transfer clock polarity
	UFORM	Select the LSB first or MSB first
UiC1	TE	Set this bit to 1 to enable transmission/reception
	TI	Transmit buffer empty flag
	RE	Set this bit to 1 to enable reception
	RI	Reception complete flag
	UIIRS	Select the UARTi transmit interrupt source
	UIRRM	Set this bit to 1 to use continuous receive mode

i = 0 or 1

NOTE:

1. Set bits which are not in this table to 0 when writing to the above registers in clock synchronous serial I/O mode.

Table 15.3 lists the I/O Pin Functions in Clock Synchronous Serial I/O Mode. The TXDi pin outputs “H” level between the operating mode selection of UARTi (i = 0 or 1) and transfer start. (If the NCH bit is set to 1 (N-channel open-drain output), this pin is in a high-impedance state.)

Table 15.3 I/O Pin Functions in Clock Synchronous Serial I/O Mode

Pin Name	Function	Selection Method
TXD0 (P1_4)	Output serial data	(Outputs dummy data when performing reception only)
RXD0 (P1_5)	Input serial data	PD1_5 bit in PD1 register = 0 (P1_5 can be used as an input port when performing transmission only)
CLK0 (P1_6)	Output transfer clock	CKDIR bit in U0MR register = 0
	Input transfer clock	CKDIR bit in U0MR register = 1 PD1_6 bit in PD1 register = 0
TXD1 (P6_6)	Output serial data	U1PINSEL bit in PMR register = 1 (Outputs dummy data when performing reception only)
RXD1 (P6_7)	Input serial data	U1PINSEL bit in PMR register = 1 PD6_7 bit in PD6 register = 0 (P6_7 can be used as an input port when performing transmission only)
CLK1 (P6_5)	Output transfer clock	U1PINSEL bit in PMR register = 1 CKDIR bit in U1MR register = 0
	Input transfer clock	U1PINSEL bit in PMR register = 1 PD6_5 bit in PD6 register = 0 CKDIR bit in U1MR register = 1

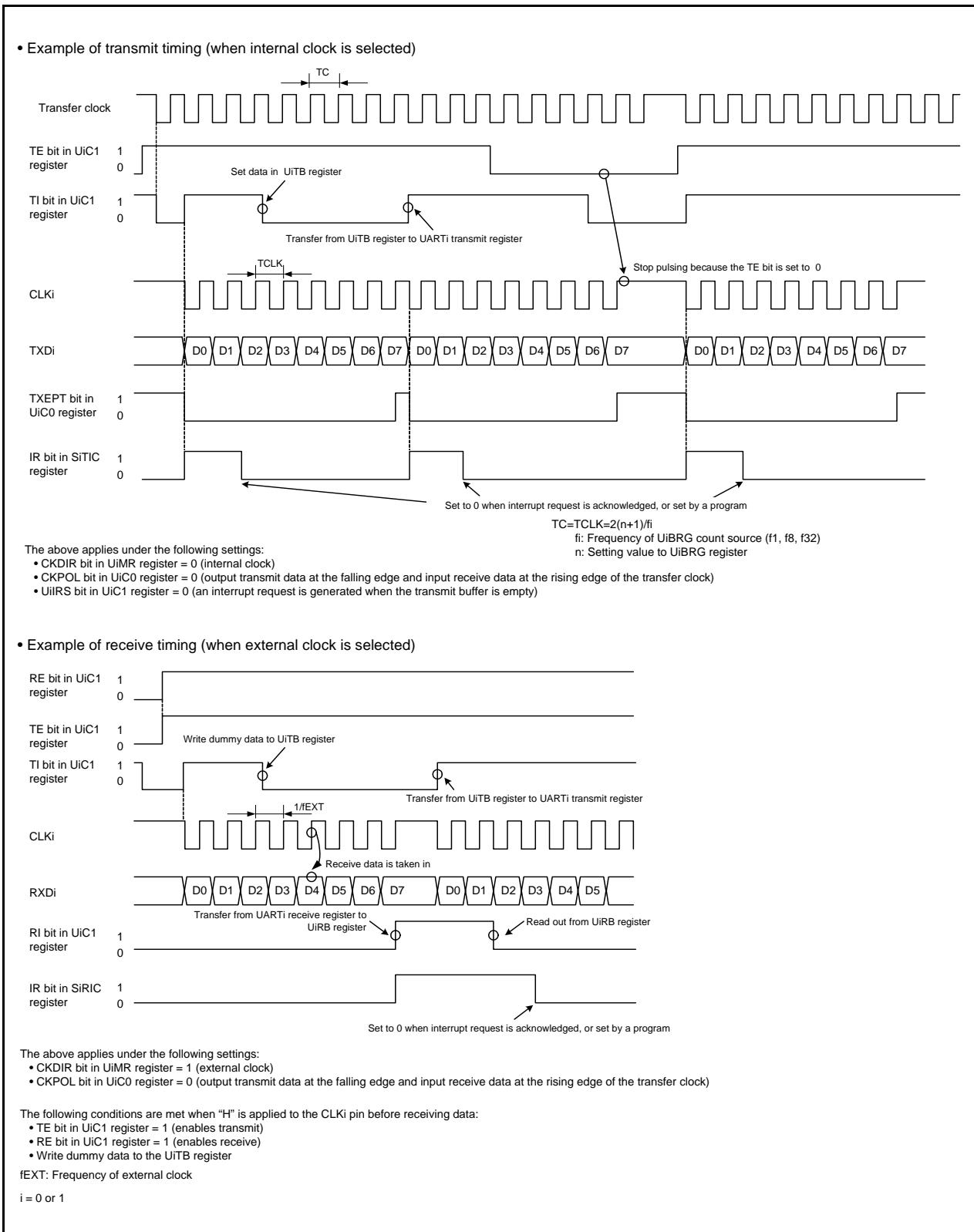

Figure 15.7 Transmit and Receive Timing Example in Clock Synchronous Serial I/O Mode

15.1.1 Polarity Select Function

Figure 15.8 shows the Transfer Clock Polarity. Use the CKPOL bit in the UiC0 (i = 0 or 1) register to select the transfer clock polarity.

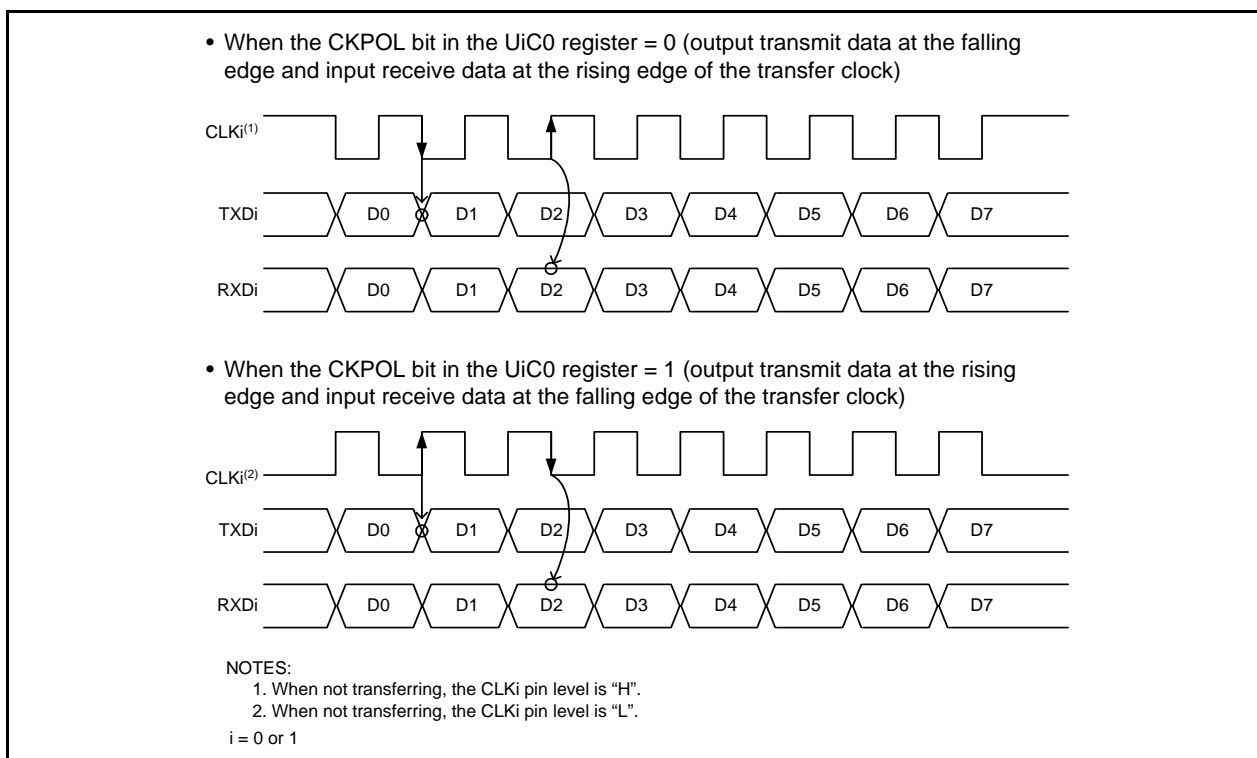

Figure 15.8 Transfer Clock Polarity

15.1.2 LSB First/MSB First Select Function

Figure 15.9 shows the Transfer Format. Use the UFORM bit in the UiC0 (i = 0 or 1) register to select the transfer format.

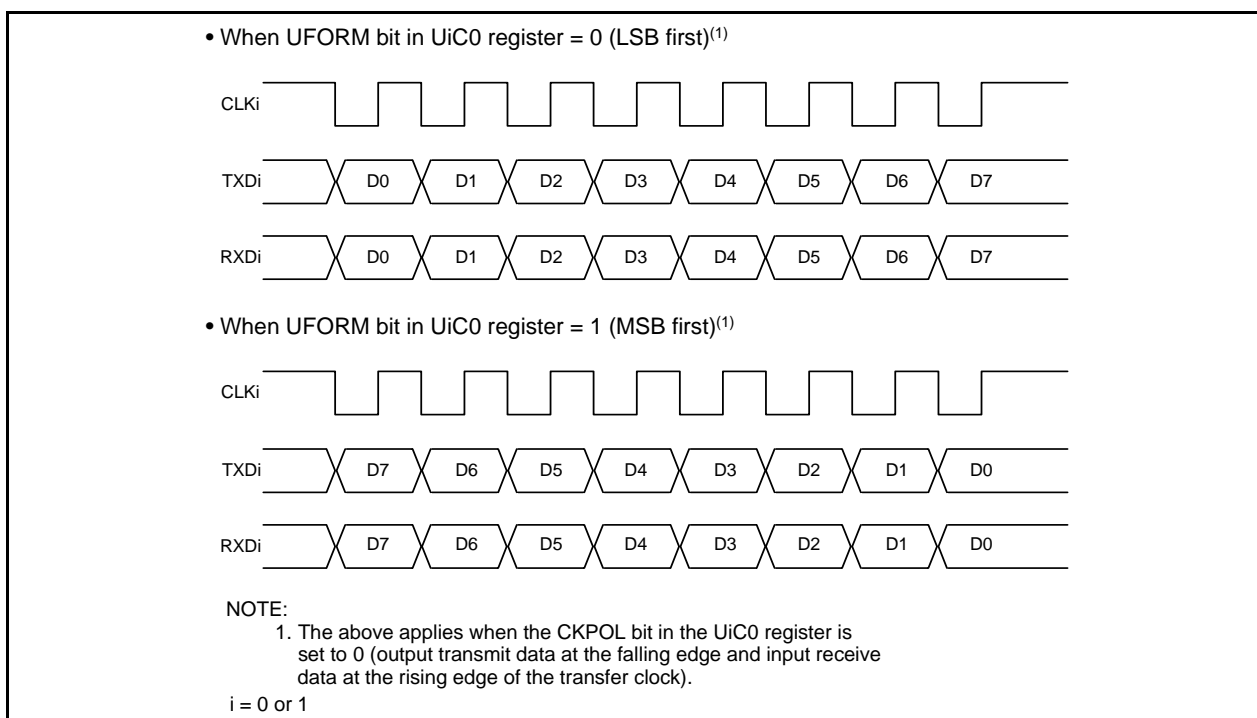

Figure 15.9 Transfer Format

15.1.3 Continuous Receive Mode

Continuous receive mode is selected by setting the UiRRM ($i = 0$ or 1) bit in the UiC1 register to 1 (enables continuous receive mode). In this mode, reading the UiRB register sets the TI bit in the UiC1 register to 0 (data in the UiTB register). When the UiRRM bit is set to 1, do not write dummy data to the UiTB register by a program.

15.2 Clock Asynchronous Serial I/O (UART) Mode

The UART mode allows data transmission and reception after setting the desired bit rate and transfer data format. Table 15.4 lists the UART Mode Specifications. Table 15.5 lists the Registers Used and Settings for UART Mode.

Table 15.4 UART Mode Specifications

Item	Specification
Transfer data formats	<ul style="list-style-type: none"> • Character bit (transfer data): Selectable among 7, 8 or 9 bits • Start bit: 1 bit • Parity bit: Selectable among odd, even, or none • Stop bit: Selectable among 1 or 2 bits
Transfer clocks	<ul style="list-style-type: none"> • CKDIR bit in UiMR register is set to 0 (internal clock): $f_j/(16(n+1))$ $f_j = f_1, f_8, f_{32}$ $n =$ value set in UiBRG register: 00h to FFh • CKDIR bit is set to 1 (external clock): $f_{EXT}/(16(n+1))$ f_{EXT}: input from CLKi pin, $n =$ value set in UiBRG register: 00h to FFh
Transmit start conditions	<ul style="list-style-type: none"> • Before transmission starts, the following are required <ul style="list-style-type: none"> - TE bit in UiC1 register is set to 1 (transmission enabled) - TI bit in UiC1 register is set to 0 (data in UiTB register)
Receive start conditions	<ul style="list-style-type: none"> • Before reception starts, the following are required <ul style="list-style-type: none"> - RE bit in UiC1 register is set to 1 (reception enabled) - Start bit detected
Interrupt request generation timing	<ul style="list-style-type: none"> • When transmitting, one of the following conditions can be selected <ul style="list-style-type: none"> - UiIRS bit is set to 0 (transmit buffer empty): When transferring data from the UiTB register to UARTi transmit register (when transmission starts). - UiIRS bit is set to 1 (transfer ends): When serial interface completes transmitting data from the UARTi transmit register • When receiving When transferring data from the UARTi receive register to UiRB register (when reception ends).
Error detection	<ul style="list-style-type: none"> • Overrun error⁽¹⁾ This error occurs if the serial interface starts receiving the next data item before reading the UiRB register and receive the bit preceding the final stop bit of the next data item. • Framing error This error occurs when the set number of stop bits is not detected. • Parity error This error occurs when parity is enabled, and the number of 1's in parity and character bits do not match the number of 1's set. • Error sum flag This flag is set is set to 1 when an overrun, framing, or parity error is generated.

i = 0 or 1

NOTE:

1. If an overrun error occurs, the receive data (b0 to b8) of the UiRB register will be undefined. The IR bit in the SiRIC register remains unchanged.

Table 15.5 Registers Used and Settings for UART Mode

Register	Bit	Function
UiTB	0 to 8	Set transmit data ⁽¹⁾
UiRB	0 to 8	Receive data can be read ⁽¹⁾
	OER,FER,PER,SUM	Error flag
UiBRG	0 to 7	Set a bit rate
UiMR	SMD2 to SMD0	Set to 100b when transfer data is 7 bits long Set to 101b when transfer data is 8 bits long Set to 110b when transfer data is 9 bits long
	CKDIR	Select the internal clock or external clock
	STPS	Select the stop bit
	PRY, PRYE	Select whether parity is included and whether odd or even
UiC0	CLK0, CLK1	Select the count source for the UiBRG register
	TXEPT	Transmit register empty flag
	NCH	Select TXDi pin output mode
	CKPOL	Set to 0
	UFORM	LSB first or MSB first can be selected when transfer data is 8 bits long. Set to 0 when transfer data is 7 or 9 bits long.
UiC1	TE	Set to 1 to enable transmit
	TI	Transmit buffer empty flag
	RE	Set to 1 to enable receive
	RI	Receive complete flag
	UiIRS	Select the source of UARTi transmit interrupt
	UiRRM	Set to 0

i = 0 or 1

NOTES:

1. The bits used for transmit/receive data are as follows: Bits 0 to 6 when transfer data is 7 bits long; bits 0 to 7 when transfer data is 8 bits long; bits 0 to 8 when transfer data is 9 bits long.

Table 15.6 lists the I/O Pin Functions in UART Mode. After the UARTi (i = 0 or 1) operating mode is selected, the TXDi pin outputs “H” level. (If the NCH bit is set to 1 (N-channel open-drain output), this pin is in a high-impedance state) until transfer starts.)

Table 15.6 I/O Pin Functions in UART Mode

Pin name	Function	Selection Method
TXD0 (P1_4)	Output serial data	(Cannot be used as a port when performing reception only)
RXD0 (P1_5)	Input serial data	PD1_5 bit in PD1 register = 0 (P1_5 can be used as an input port when performing transmission only)
CLK0 (P1_6)	Programmable I/O Port	CKDIR bit in U0MR register = 0
	Input transfer clock	CKDIR bit in U0MR register = 1 PD1_6 bit in PD1 register = 0
TXD1 (P6_6)	Output serial data	U1PINSEL bit in PMR register = 1 (Cannot be used as a port when performing reception only)
RXD1 (P6_7)	Input serial data	U1PINSEL bit in PMR register = 1 PD6_7 bit in PD6 register = 0 (P6_7 can be used as an input port when performing transmission only)
CLK1 (P6_5)	Programmable I/O Port	CKDIR bit in U1MR register = 0
	Input transfer clock	U1PINSEL bit in PMR register = 1 PD6_5 bit in PD6 register = 0 CKDIR bit in U1MR register = 1

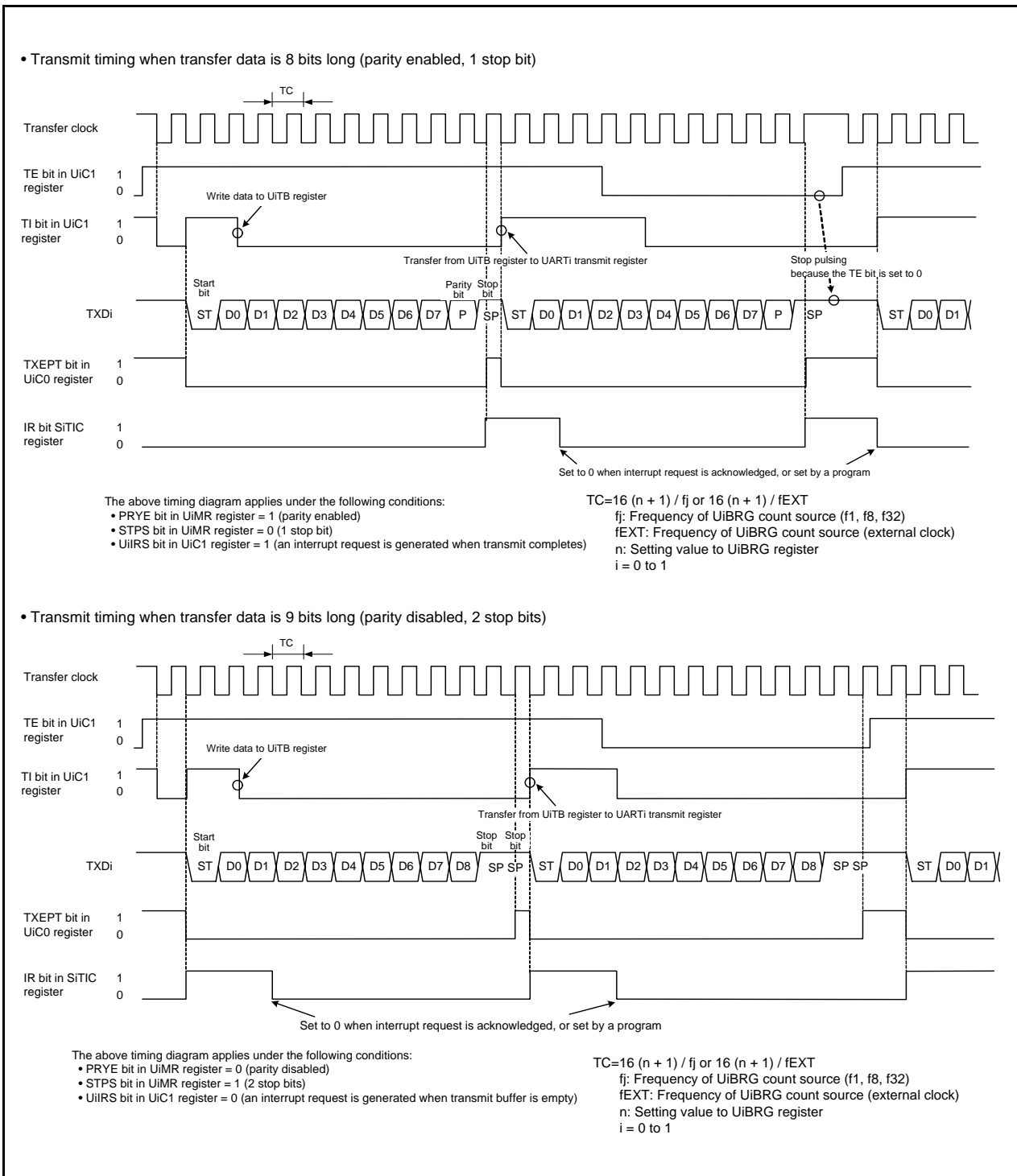

Figure 15.10 Transmit Timing in UART Mode

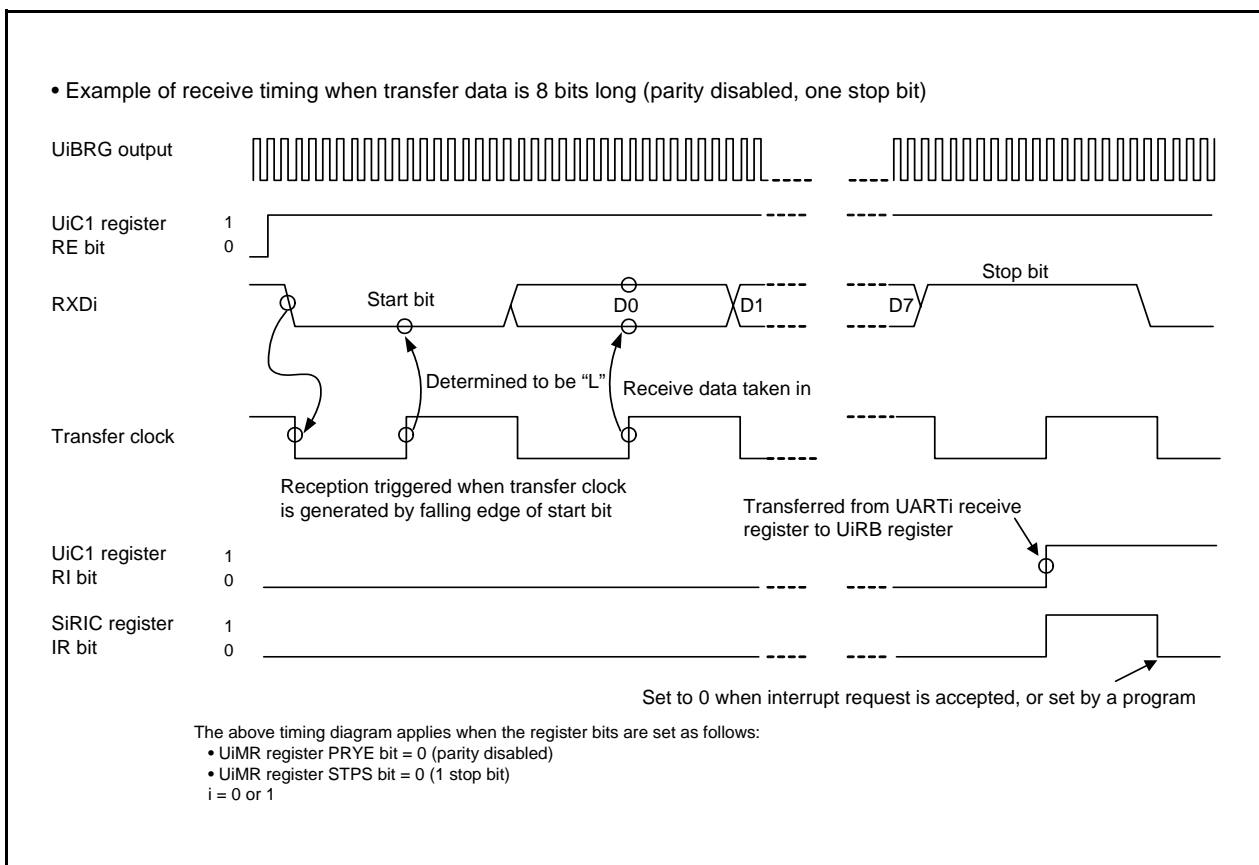

Figure 15.11 Receive Timing Example in UART Mode

15.2.1 Bit Rate

In UART mode, the bit rate is the frequency divided by the UiBRG (i = 0 or 1) register.

UART mode	
• Internal clock selected	
$\text{UiBRG register setting value} = \frac{f_j}{\text{Bit Rate} \times 16} - 1$	
Fj: Count source frequency of the UiBRG register (f1, f8, or f32)	
• External clock selected	
$\text{UiBRG register setting value} = \frac{f_{\text{EXT}}}{\text{Bit Rate} \times 16} - 1$	
fEXT: Count source frequency of the UiBRG register (external clock)	
i = 0 or 1	

Figure 15.12 Calculation Formula of UiBRG (i = 0 or 1) Register Setting Value

Table 15.7 Bit Rate Setting Example in UART Mode (Internal Clock Selected)

Bit Rate (bps)	BRG Count Source	System Clock = 20 MHz			System Clock = 8 MHz		
		UiBRG Setting Value	Actual Time (bps)	Error (%)	UiBRG Setting Value	Actual Time (bps)	Error (%)
1200	f8	129 (81h)	1201.92	0.16	51 (33h)	1201.92	0.16
2400	f8	64 (40h)	2403.85	0.16	25 (19h)	2403.85	0.16
4800	f8	32 (20h)	4734.85	-1.36	12 (0Ch)	4807.69	0.16
9600	f1	129 (81h)	9615.38	0.16	51 (33h)	9615.38	0.16
14400	f1	86 (56h)	14367.82	-0.22	34 (22h)	14285.71	-0.79
19200	f1	64 (40h)	19230.77	0.16	25 (19h)	19230.77	0.16
28800	f1	42 (2Ah)	29069.77	0.94	16 (10h)	29411.76	2.12
31250	f1	39 (27h)	31250.00	0.00	15 (0Fh)	31250.00	0.00
38400	f1	32 (20h)	37878.79	-1.36	12 (0Ch)	38461.54	0.16
51200	f1	23 (17h)	52083.33	1.73	9 (09h)	50000.00	-2.34

i = 0 or 1

15.3 Notes on Serial Interface

- When reading data from the UiRB (i = 0 or 1) register either in the clock synchronous serial I/O mode or in the clock asynchronous serial I/O mode. Ensure the data is read in 16-bit units. When the high-order byte of the UiRB register is read, bits PER and FER in the UiRB register and the RI bit in the UiC1 register are set to 0.

Example (when reading receive buffer register):

```
MOV.W    00A6H,R0    ; Read the UORB register
```

- When writing data to the UiTB register in the clock asynchronous serial I/O mode with 9-bit transfer data length, write data to the high-order byte first then the low-order byte, in 8-bit units.

Example (when reading transmit buffer register):

```
MOV.B    #XXH,00A3H  ; Write the high-order byte of U0TB register  
MOV.B    #XXH,00A2H  ; Write the low-order byte of U0TB register
```

16. Clock Synchronous Serial Interface

The clock synchronous serial interface is configured as follows.

Clock synchronous serial interface

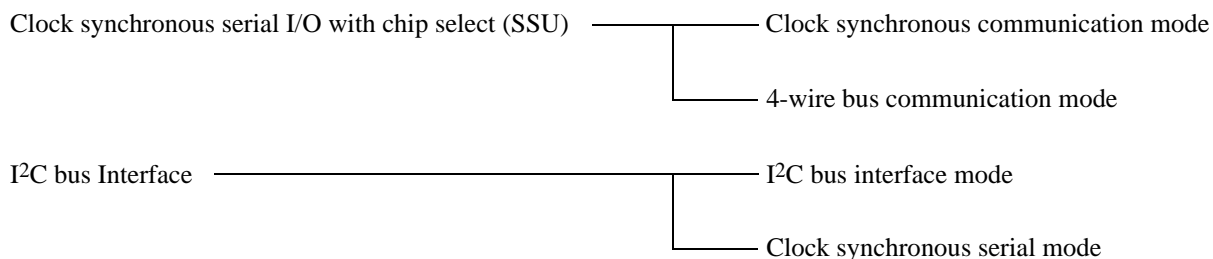

The clock synchronous serial interface uses the registers at addresses 00B8h to 00BFh. Registers, bits, symbols, and functions vary even for the same addresses depending on the mode. Refer to the register diagrams of each function for details.

Also, the differences between clock synchronous communication mode and clock synchronous serial mode are the options of the transfer clock, clock output format, and data output format.

16.1 Mode Selection

The clock synchronous serial interface has four modes.

Table 16.1 lists the Mode Selections. Refer to **16.2 Clock Synchronous Serial I/O with Chip Select (SSU)** and the sections that follow for details of each mode.

Table 16.1 Mode Selections

IICSEL Bit in PMR Register	Bit 7 in 00B8h (ICE Bit in ICCR1 Register)	Bit 0 in 00BDh (SSUMS Bit in SSMR2 Register, FS Bit in SAR Register)	Function	Mode
0	0	0	Clock synchronous serial I/O with chip select	Clock synchronous communication mode
0	0	1		4-wire bus communication mode
1	1	0	I ² C bus interface	I ² C bus interface mode
1	1	1		Clock synchronous serial mode

16.2 Clock Synchronous Serial I/O with Chip Select (SSU)

Clock synchronous serial I/O with chip select supports clock synchronous serial data communication.

Table 16.2 shows a Clock Synchronous Serial I/O with Chip Select Specifications and Figure 16.1 shows a Block Diagram of Clock Synchronous Serial I/O with Chip Select. Figures 16.2 to 16.9 show Clock Synchronous Serial I/O with Chip Select Associated Registers.

Table 16.2 Clock Synchronous Serial I/O with Chip Select Specifications

Item	Specification
Transfer data format	<ul style="list-style-type: none"> Transfer data length: 8 bits Continuous transmission and reception of serial data are supported since both transmitter and receiver have buffer structures.
Operating modes	<ul style="list-style-type: none"> Clock synchronous communication mode 4-wire bus communication mode (including bidirectional communication)
Master/slave device	Selectable
I/O pins	SSCK (I/O): Clock I/O pin SSI (I/O): Data I/O pin SSO (I/O): Data I/O pin $\overline{\text{SCS}}$ (I/O): Chip-select I/O pin
Transfer clocks	<ul style="list-style-type: none"> When the MSS bit in the SSCRH register is set to 0 (operates as slave device), external clock is selected (input from SSCK pin). When the MSS bit in the SSCRH register is set to 1 (operates as master device), internal clock (selectable among f1/256, f1/128, f1/64, f1/32, f1/16, f1/8 and f1/4, output from SSCK pin) is selected. Clock polarity and phase of SSCK can be selected.
Receive error detection	<ul style="list-style-type: none"> Overrun error Overrun error occurs during reception and completes in error. While the RDRF bit in the SSSR register is set to 1 (data in the SSRDR register) and when next serial data receive is completed, the ORER bit is set to 1.
Multimaster error detection	<ul style="list-style-type: none"> Conflict error When the SSUMS bit in the SSMR2 register is set to 1 (4-wire bus communication mode) and the MSS bit in the SSCRH register is set to 1 (operates as master device) and when starting a serial communication, the CE bit in the SSSR register is set to 1 if "L" applies to the $\overline{\text{SCS}}$ pin input. When the SSUMS bit in the SSMR2 register is set to 1 (4-wire bus communication mode), the MSS bit in the SSCRH register is set to 0 (operates as slave device) and the $\overline{\text{SCS}}$ pin input changes state from "L" to "H", the CE bit in the SSSR register is set to 1.
Interrupt requests	5 interrupt requests (transmit-end, transmit-data-empty, receive-data-full, overrun error, and conflict error) ⁽¹⁾ .
Select functions	<ul style="list-style-type: none"> Data transfer direction Selects MSB-first or LSB-first SSCK clock polarity Selects "L" or "H" level when clock stops SSCK clock phase Selects edge of data change and data download

NOTE:

1. Clock synchronous serial I/O with chip select has only one interrupt vector table.

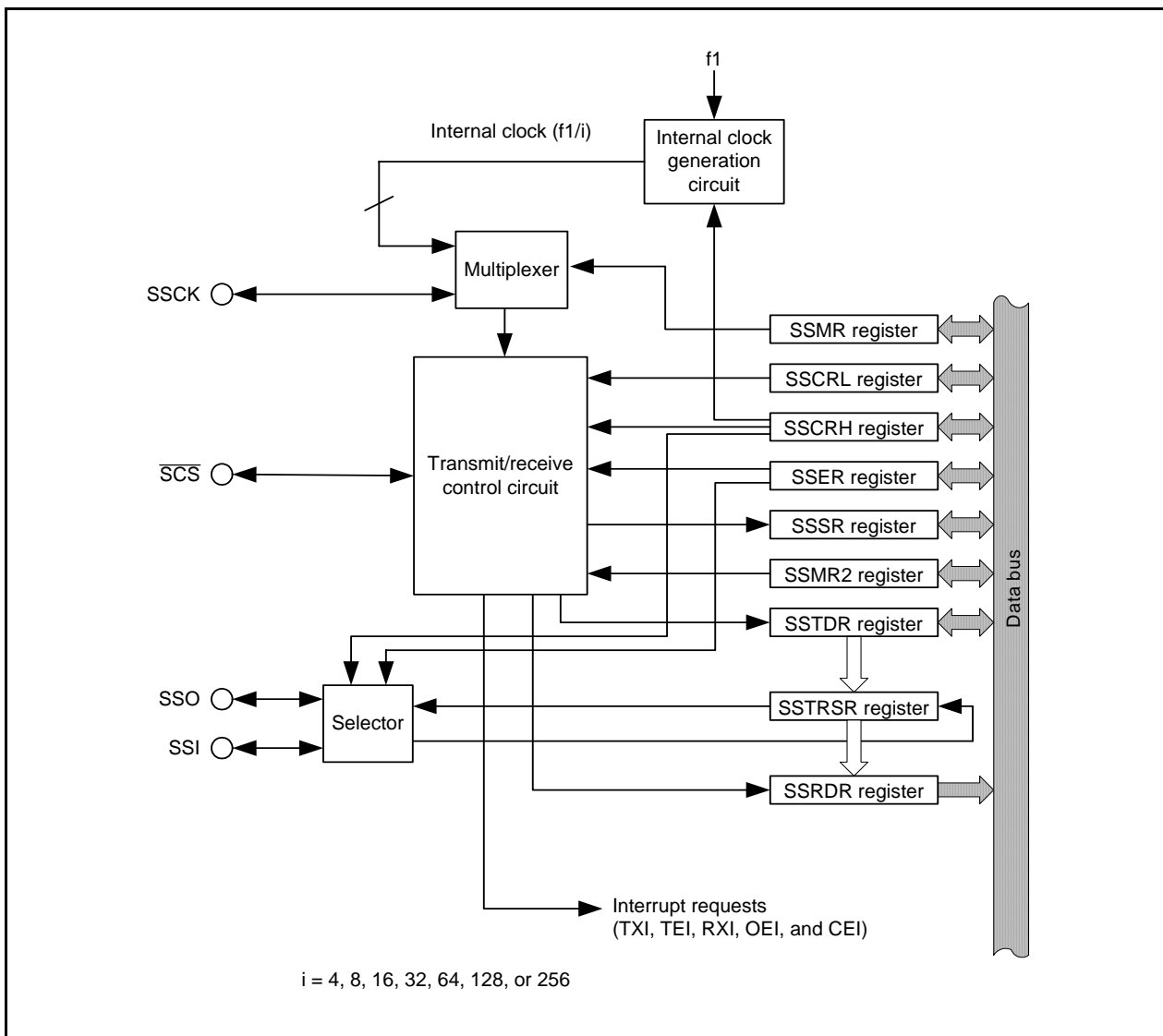

Figure 16.1 Block Diagram of Clock Synchronous Serial I/O with Chip Select

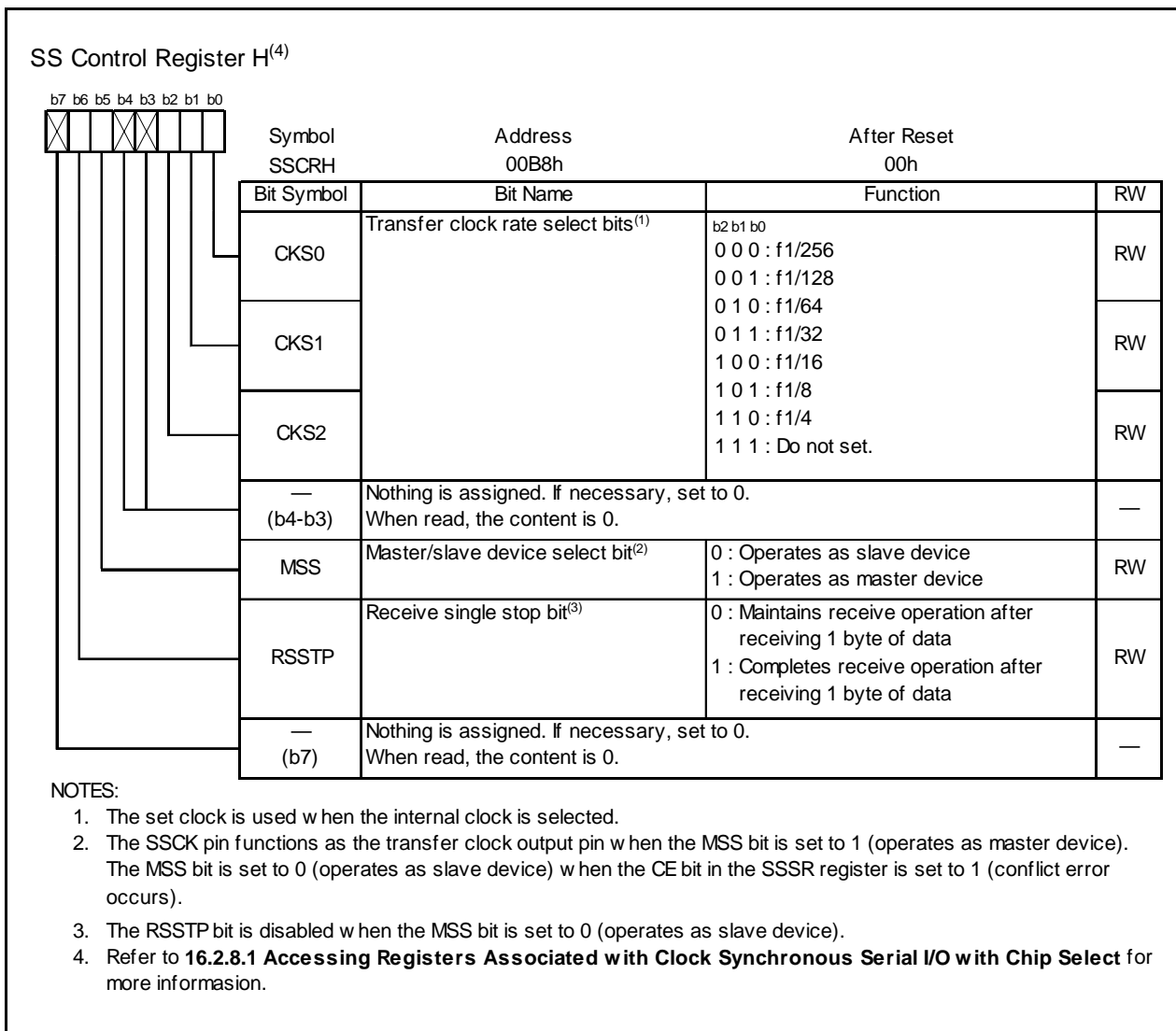

Figure 16.2 SSCRH Register

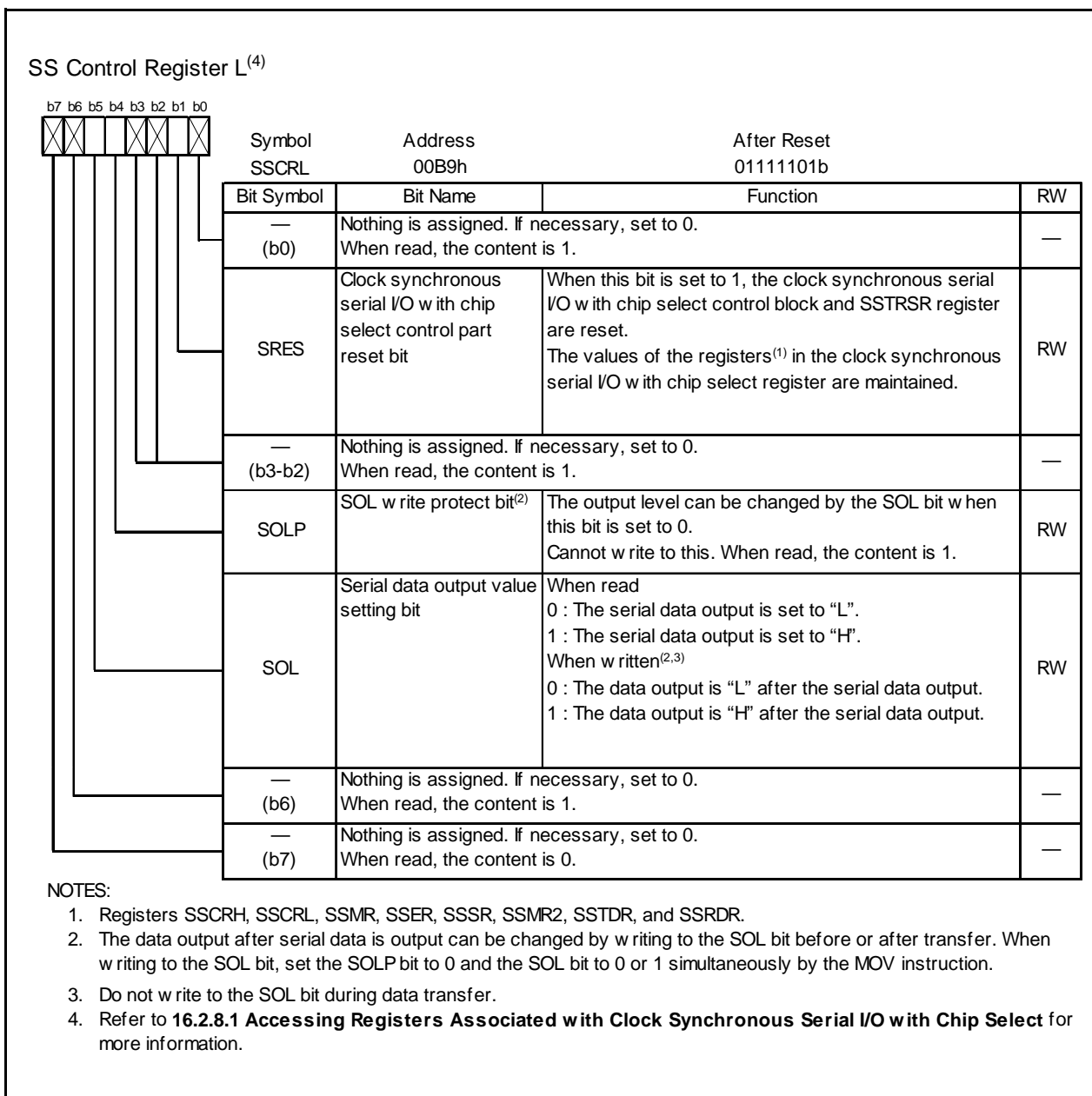

Figure 16.3 SSCRL Register

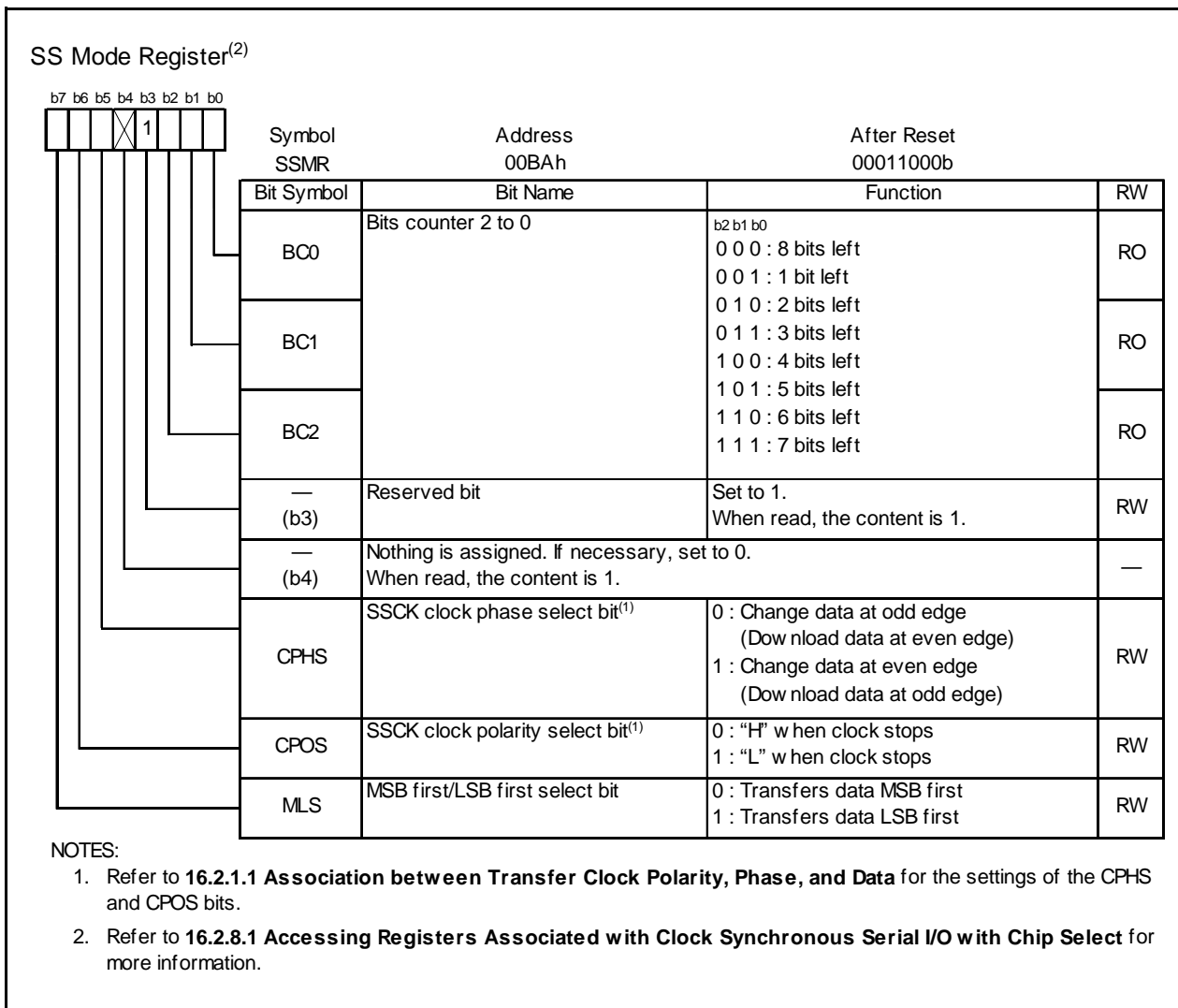

Figure 16.4 SSMR Register

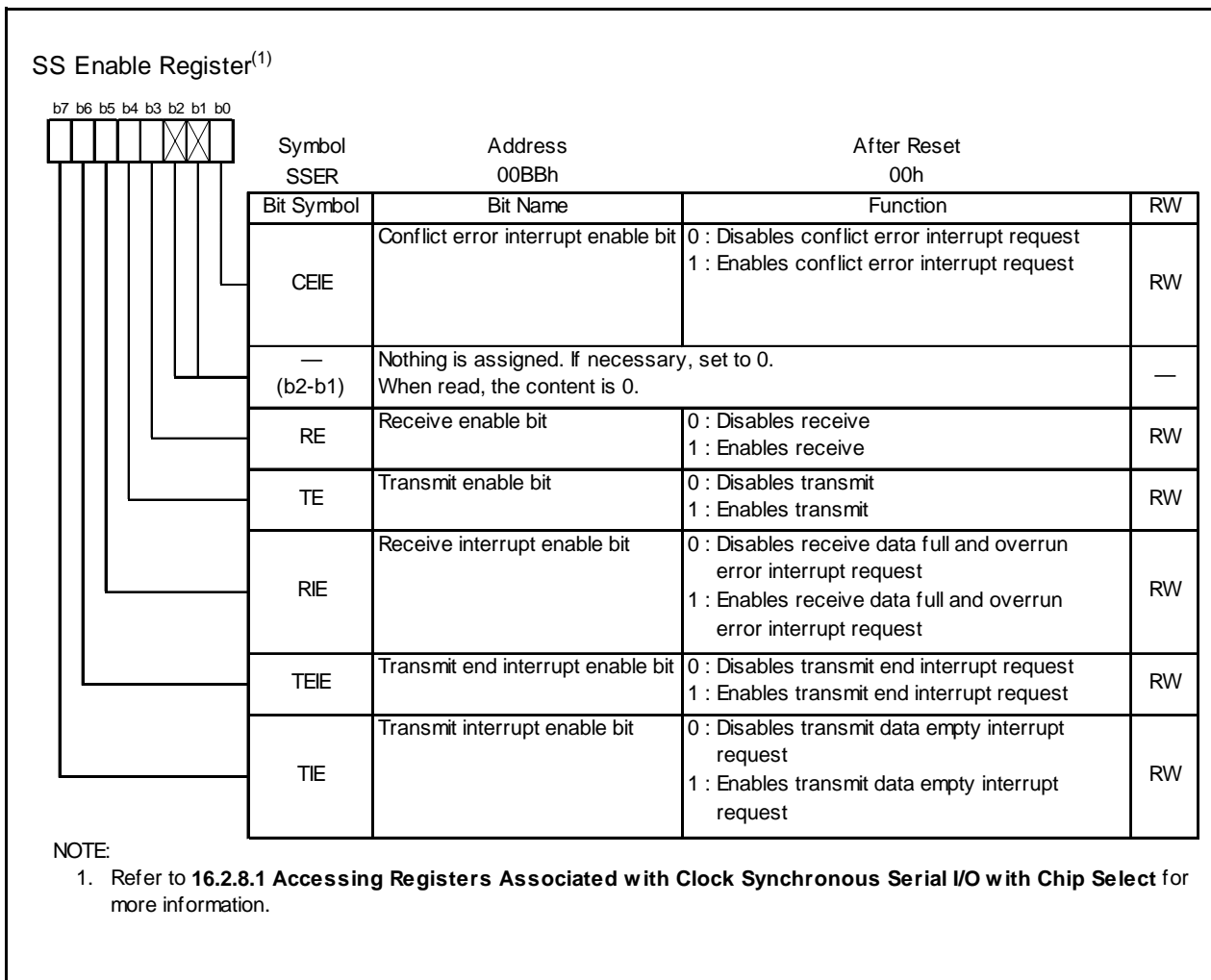

Figure 16.5 SSER Register

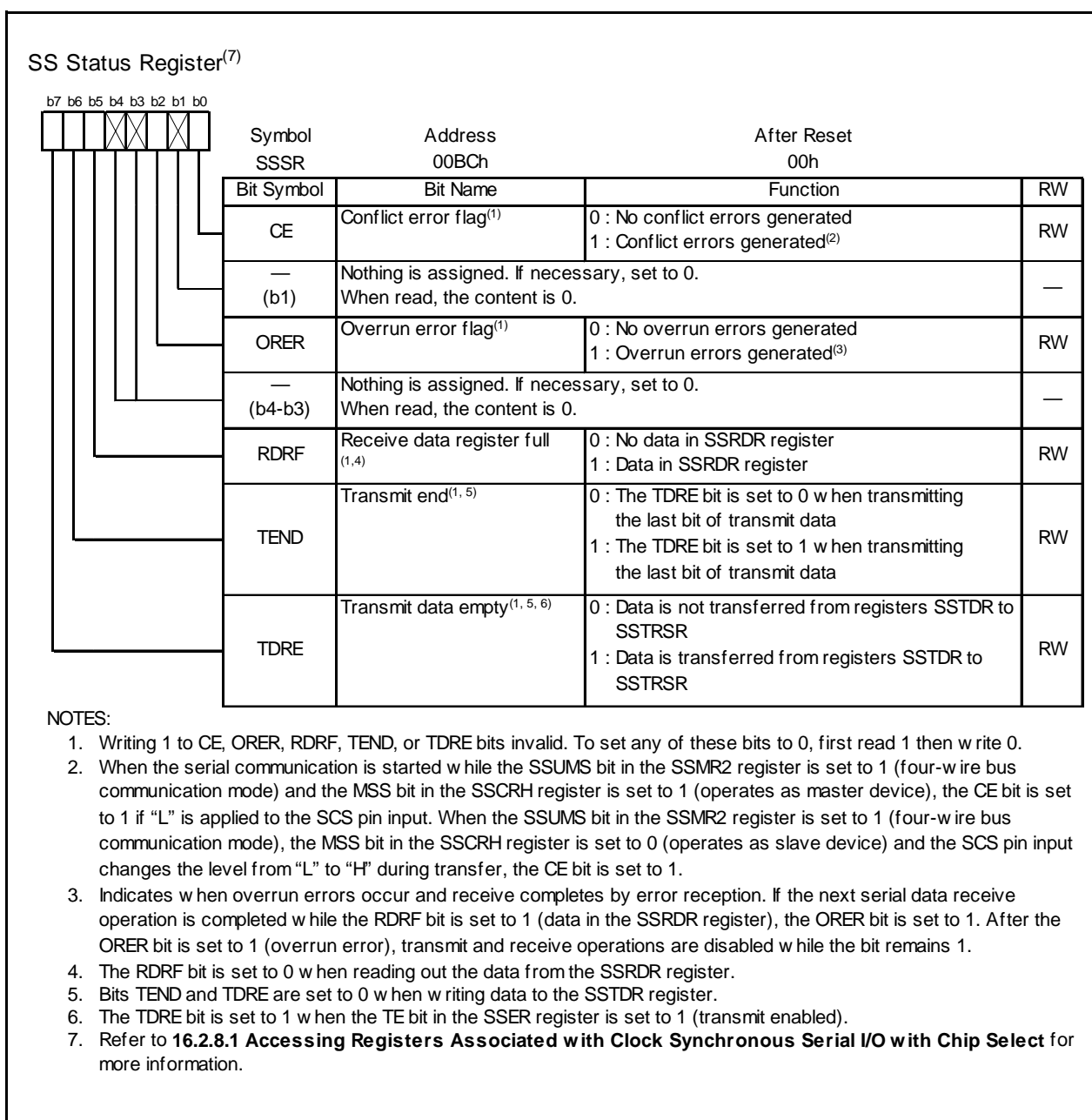

Figure 16.6 SSSR Register

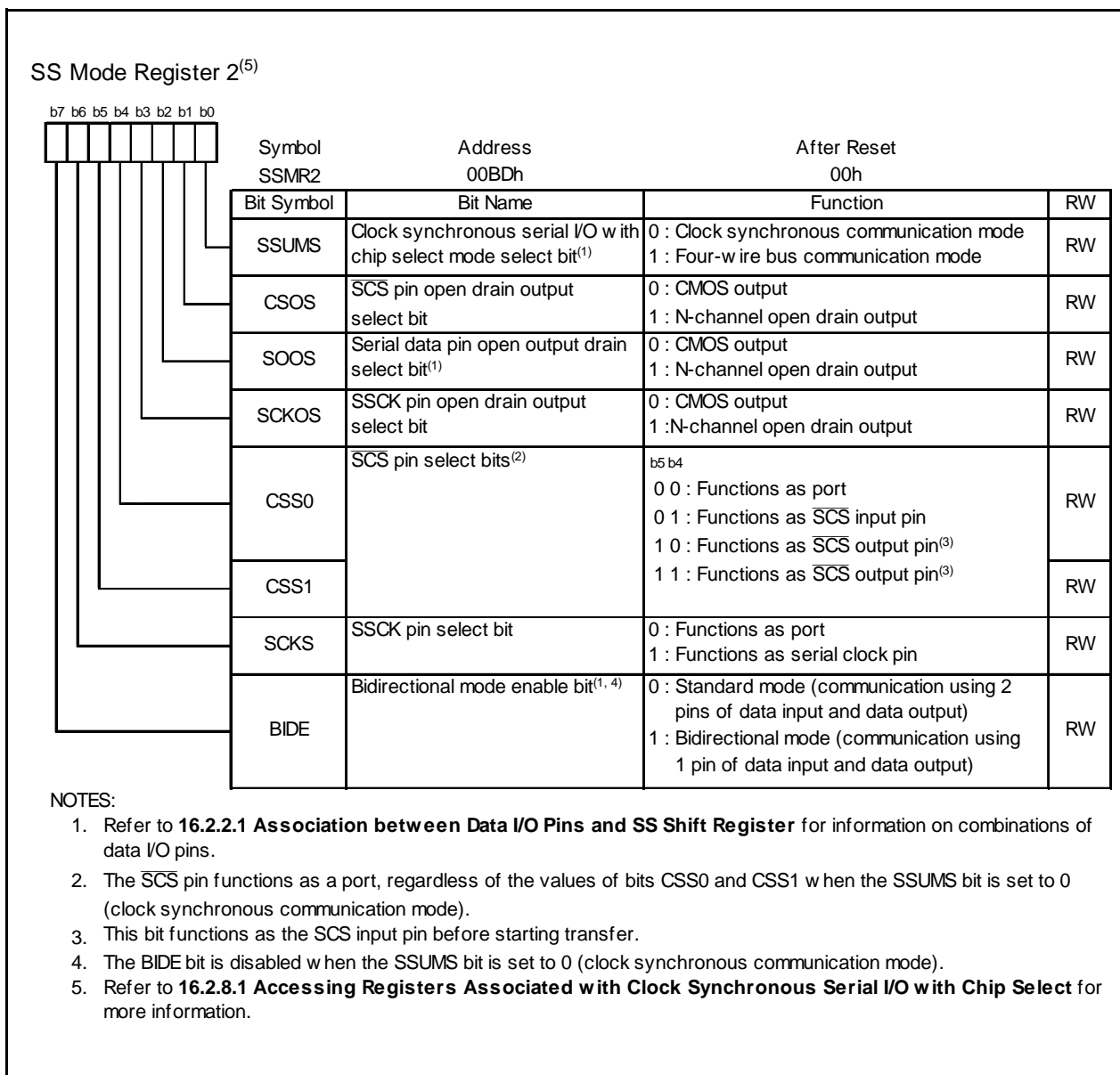

Figure 16.7 SSMR2 Register

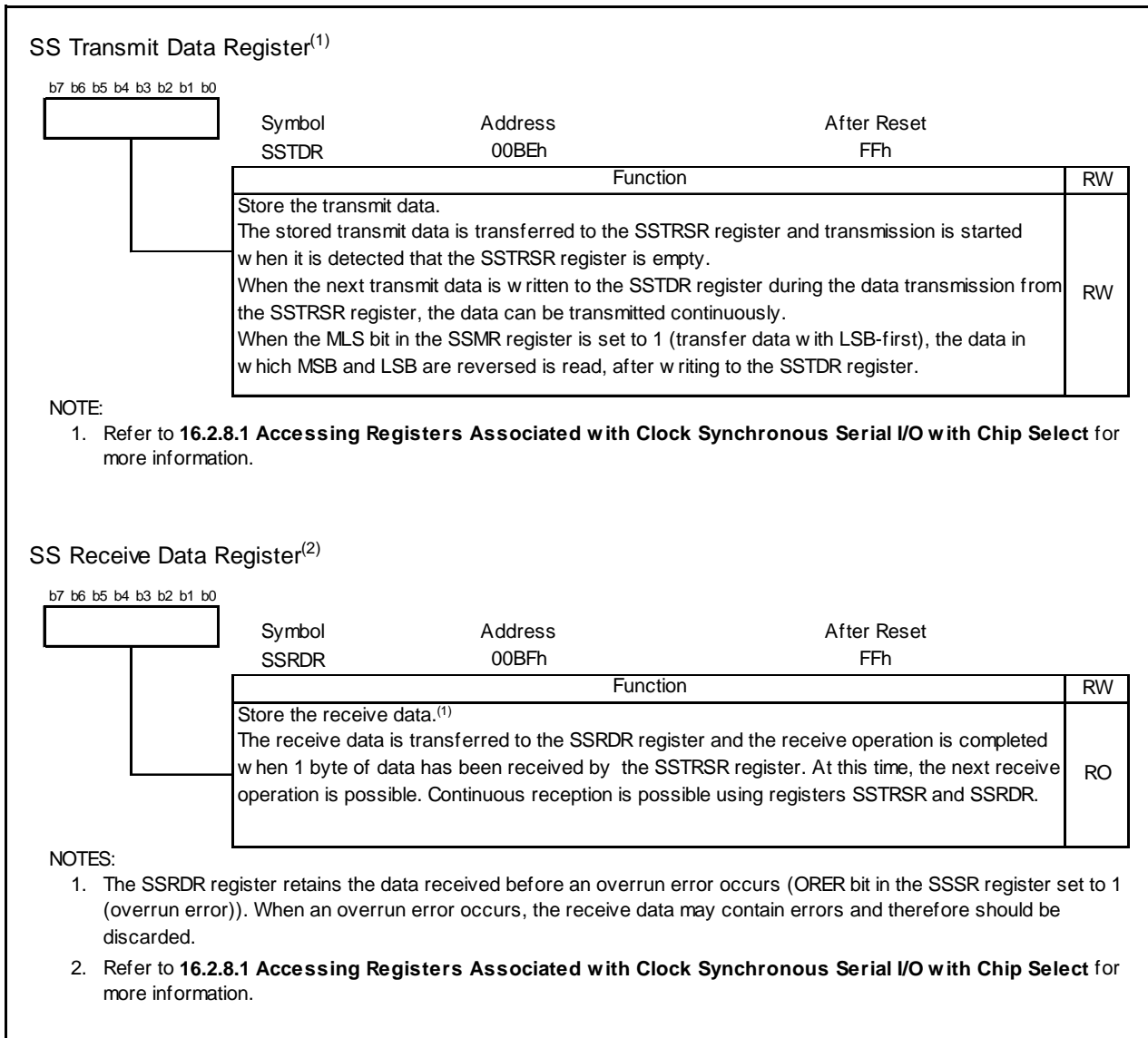

Figure 16.8 Registers SSTDR and SSRDR

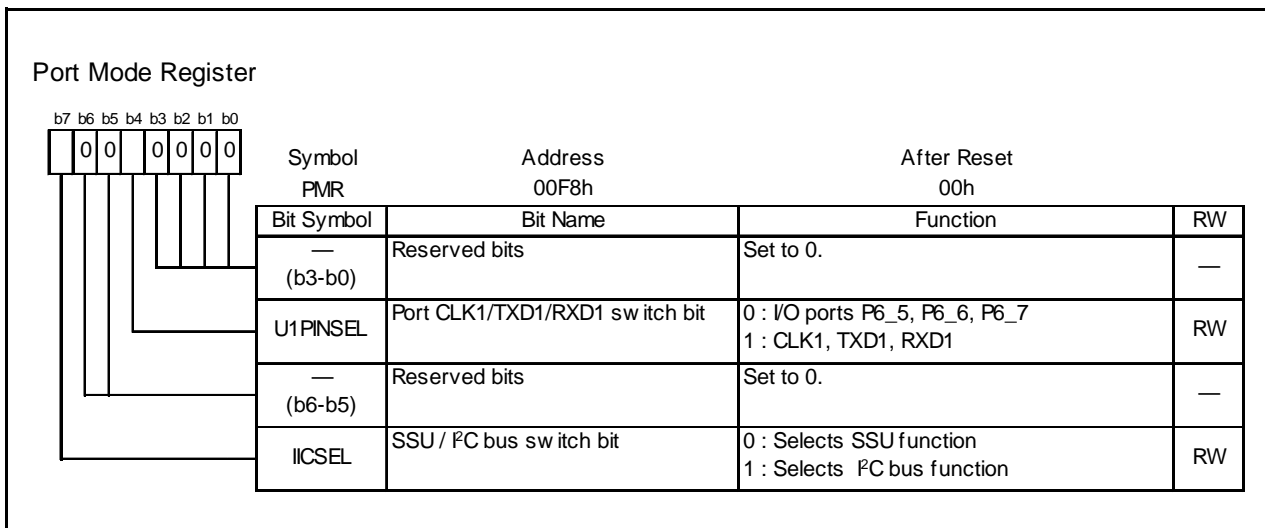

Figure 16.9 PMR Register

16.2.1 Transfer Clock

The transfer clock can be selected from among seven internal clocks (f1/256, f1/128, f1/64, f1/32, f1/16, f1/8, and f1/4) and an external clock.

When using clock synchronous serial I/O with chip select, set the SCKS bit in the SSMR2 register to 1 and select the SSCK pin as the serial clock pin.

When the MSS bit in the SSCRH register is set to 1 (operates as master device), an internal clock can be selected and the SSCK pin functions as output. When transfer is started, the SSCK pin outputs clocks of the transfer rate selected by bits CKS0 to CKS2 in the SSCRH register.

When the MSS bit in the SSCRH register is set to 0 (operates as slave device), an external clock can be selected and the SSCK pin functions as input.

16.2.1.1 Association between Transfer Clock Polarity, Phase, and Data

The association between the transfer clock polarity, phase and data changes according to the combination of the SSUMS bit in the SSMR2 register and bits CPHS and CPOS in the SSMR register.

Figure 16.10 shows the Association between Transfer Clock Polarity, Phase, and Transfer Data.

Also, the MSB-first transfer or LSB-first transfer can be selected by setting the MLS bit in the SSMR register. When the MLS bit is set to 1, transfer is started from the LSB and proceeds to the MSB. When the MLS bit is set to 0, transfer is started from the MSB and proceeds to the LSB.

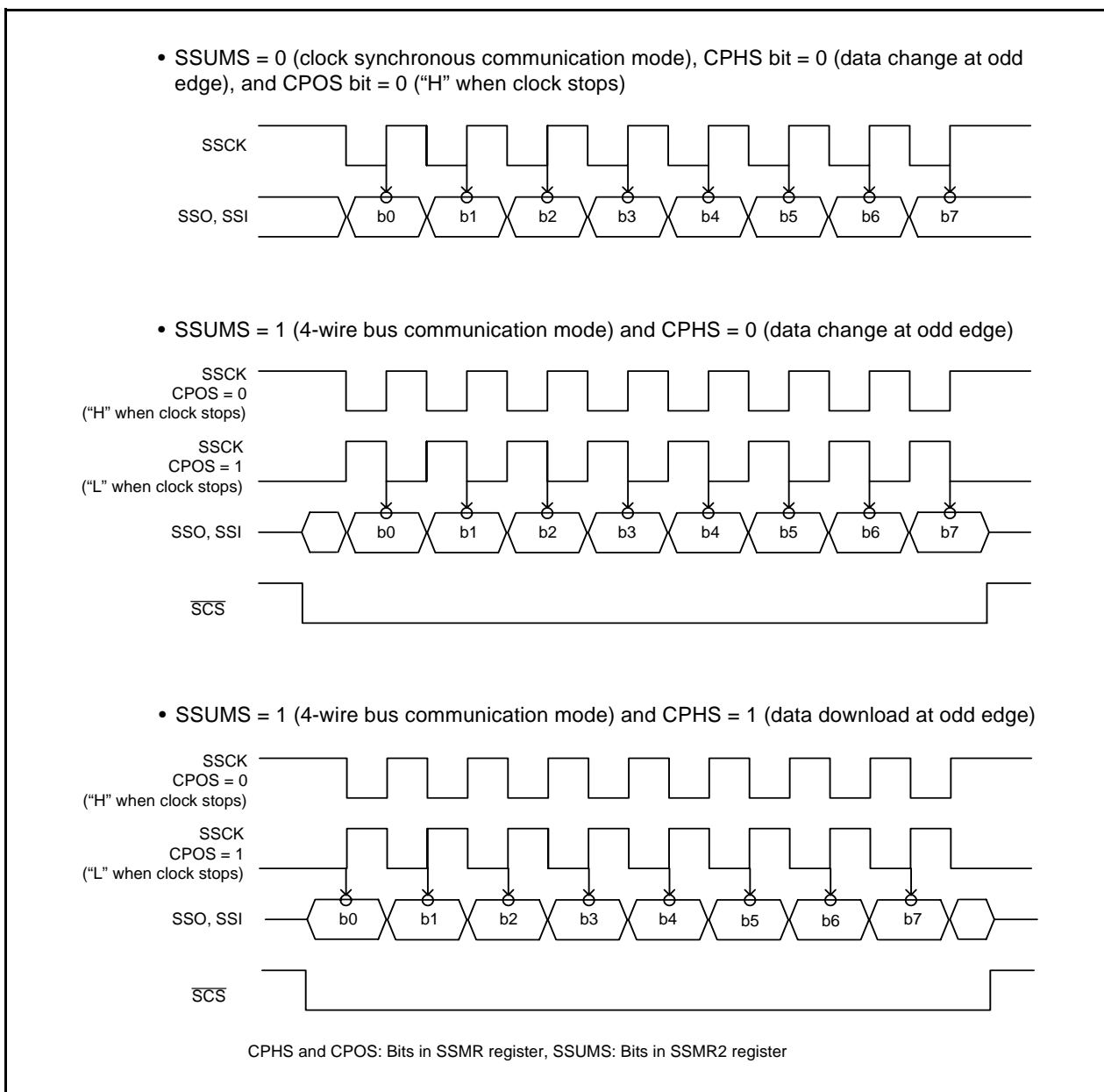

Figure 16.10 Association between Transfer Clock Polarity, Phase, and Transfer Data

16.2.2 SS Shift Register (SSTRSR)

The SSTRSR register is a shift register for transmitting and receiving serial data.

When transmit data is transferred from the SSTDR register to the SSTRSR register and the MLS bit in the SSMR register is set to 0 (MSB-first), the bit 0 in the SSTDR register is transferred to bit 0 in the SSTRSR register. When the MLS bit is set to 1 (LSB-first), bit 7 in the SSTDR register is transferred to bit 0 in the SSTRSR register.

16.2.2.1 Association between Data I/O Pins and SS Shift Register

The connection between the data I/O pins and SSTRSR register (SS shift register) changes according to a combination of the MSS bit in the SSCRH register and the SSUMS bit in the SSMR2 register. The connection also changes according to the BIDE bit in the SSMR2 register.

Figure 16.11 shows the Association between Data I/O Pins and SSTRSR Register.

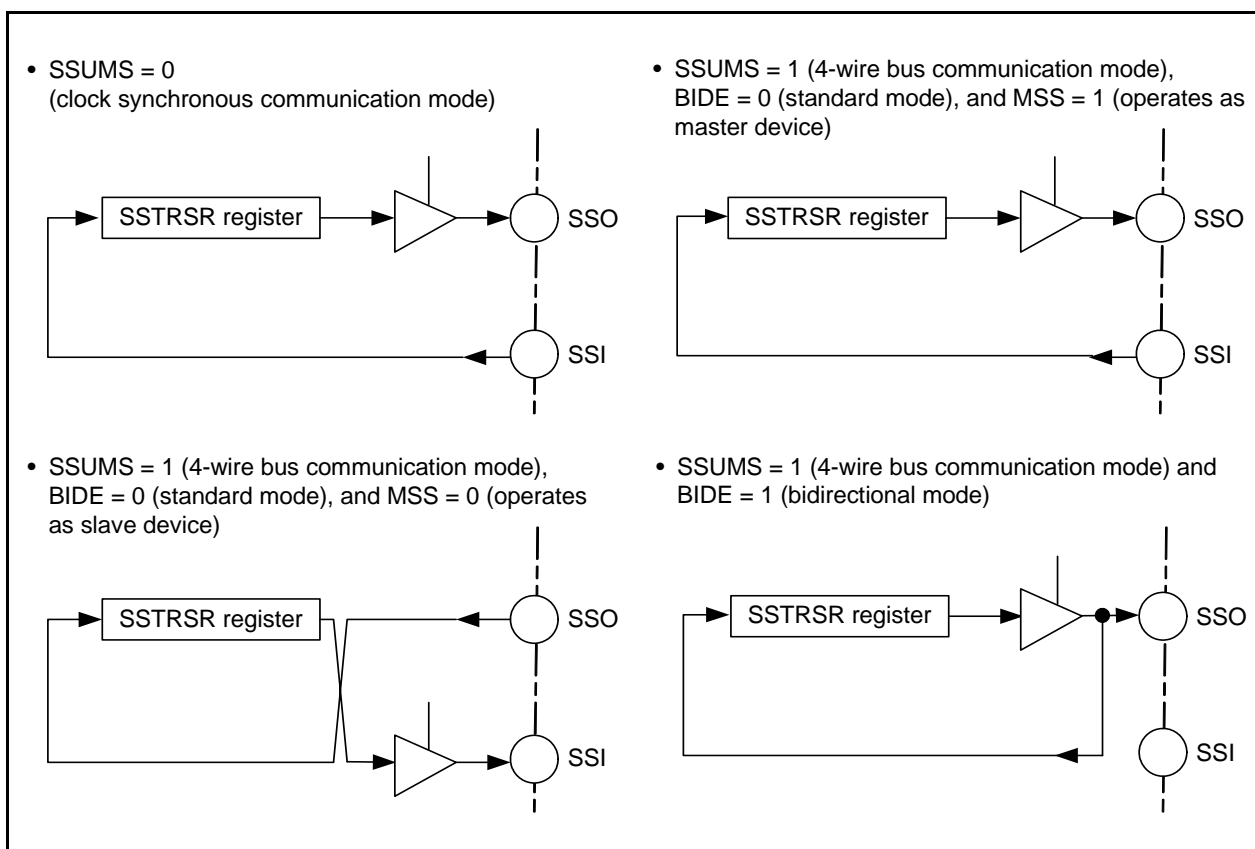

Figure 16.11 Association between Data I/O Pins and SSTRSR Register

16.2.3 Interrupt Requests

Clock synchronous serial I/O with chip select has five interrupt requests: transmit data empty, transmit end, receive data full, overrun error, and conflict error. Since these interrupt requests are assigned to the clock synchronous serial I/O with chip select interrupt vector table, determining interrupt sources by flags is required. Table 16.3 shows the Clock Synchronous Serial I/O with Chip Select Interrupt Requests.

Table 16.3 Clock Synchronous Serial I/O with Chip Select Interrupt Requests

Interrupt Request	Abbreviation	Generation Condition
Transmit data empty	TXI	TIE = 1, TDRE = 1
Transmit end	TEI	TEIE = 1, TEND = 1
Receive data full	RXI	RIE = 1, RDRF = 1
Overrun error	OEI	RIE = 1, ORER = 1
Conflict error	CEI	CEIE = 1, CE = 1

CEIE, RIE, TEIE and TIE: Bits in SSER register

ORER, RDRF, TEND and TDRE: Bits in SSSR register

If the generation conditions in Table 16.3 are met, a clock synchronous serial I/O with chip select interrupt request is generated. Set each interrupt source to 0 by a clock synchronous serial I/O with chip select interrupt routine.

However, the TDRE and TEND bits are automatically set to 0 by writing transmit data to the SSTDR register and the RDRF bit is automatically set to 0 by reading the SSRDR register. In particular, the TDRE bit is set to 1 (data transmitted from registers SSTDR to SSTRSR) at the same time transmit data is written to the SSTDR register. Setting the TDRE bit to 0 (data not transmitted from registers SSTDR to SSTRSR) can cause an additional byte of data to be transmitted.

16.2.4 Communication Modes and Pin Functions

Clock synchronous serial I/O with chip select switches the functions of the I/O pins in each communication mode according to the setting of the MSS bit in the SSCRH register and bits RE and TE in the SSER register. Table 16.4 shows the Association between Communication Modes and I/O Pins.

Table 16.4 Association between Communication Modes and I/O Pins

Communication Mode	Bit Setting					Pin State		
	SSUMS	BIDE	MSS	TE	RE	SSI	SSO	SSCK
Clock synchronous communication mode	0	Disabled	0	0	1	Input	–(1)	Input
				1	0	–(1)	Output	Input
				1	1	Input	Output	Input
			1	0	1	Input	–(1)	Output
				1	0	–(1)	Output	Output
				1	1	Input	Output	Output
4-wire bus communication mode	1	0	0	0	1	–(1)	Input	Input
				1	0	Output	–(1)	Input
				1	1	Output	Input	Input
			1	0	1	Input	–(1)	Output
				1	0	–(1)	Output	Output
				1	1	Input	Output	Output
4-wire bus (bidirectional) communication mode ⁽²⁾	1	1	0	0	1	–(1)	Input	Input
				1	0	–(1)	Output	Input
			1	0	1	–(1)	Input	Output
				1	0	–(1)	Output	Output

NOTES:

1. This pin can be used as a programmable I/O port.
2. Do not set both bits TE and RE to 1 in 4-wire bus (bidirectional) communication mode.

SSUMS and BIDE: Bits in SSMR2 register

MSS: Bit in SSCRH register

TE and RE: Bits in SSER register

16.2.5 Clock Synchronous Communication Mode

16.2.5.1 Initialization in Clock Synchronous Communication Mode

Figure 16.12 shows Initialization in Clock Synchronous Communication Mode. To initialize, set the TE bit in the SSER register to 0 (transmit disabled) and the RE bit to 0 (receive disabled) before data transmission or reception.

Set the TE bit to 0 and the RE bit to 0 before changing the communication mode or format.

Setting the RE bit to 0 does not change the contents of flags RDRF and ORER or the contents of the SSRDR register.

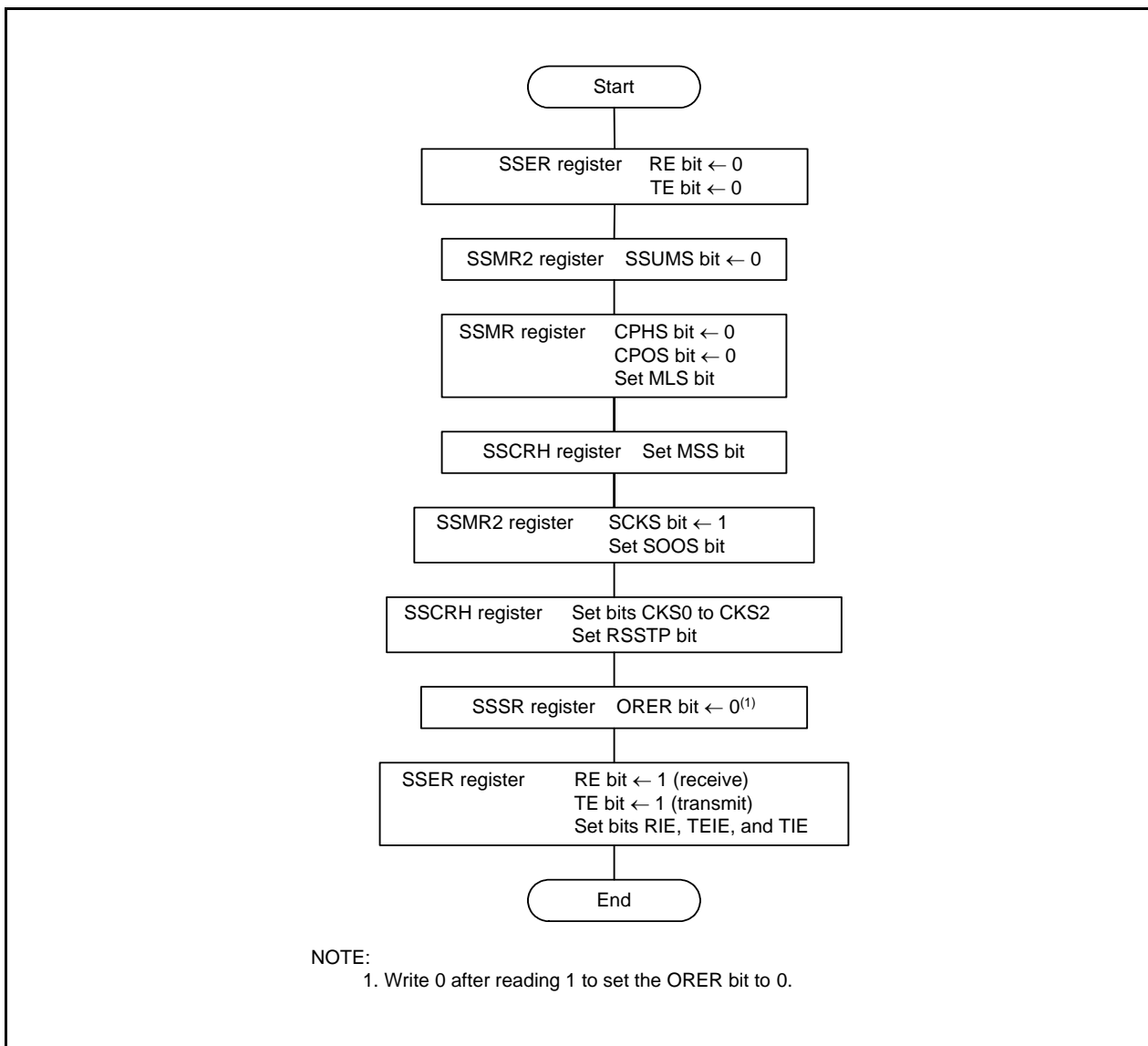

Figure 16.12 Initialization in Clock Synchronous Communication Mode

16.2.5.2 Data Transmission

Figure 16.13 shows an Example of Clock Synchronous Serial I/O with Chip Select Operation for Data Transmission (Clock Synchronous Communication Mode). During data transmission, the clock synchronous serial I/O with chip select operates as described below.

When clock synchronous serial I/O with chip select is set as a master device, it outputs a synchronous clock and data. When clock synchronous serial I/O with chip select is set as a slave device, it outputs data synchronized with the input clock.

When the TE bit is set to 1 (transmit enabled) before writing the transmit data to the SSTDR register, the TDRE bit is automatically set to 0 (data not transferred from registers SSTDR to SSTRSR) and the data is transferred from registers SSTDR to SSTRSR.

After the TDRE bit is set to 1 (data transferred from registers SSTDR to SSTRSR), transmission starts. When the TIE bit in the SSER register is set to 1, the TXI interrupt request is generated. When one frame of data is transferred while the TDRE bit is set to 0, data is transferred from registers SSTDR to SSTRSR and transmission of the next frame is started. If the 8th bit is transmitted while the TDRE bit is set to 1, the TEND bit in the SSSR register is set to 1 (the TDRE bit is set to 1 when the last bit of the transmit data is transmitted) and the state is retained. The TEI interrupt request is generated when the TEIE bit in the SSER register is set to 1 (transmit-end interrupt request enabled). The SSCK pin is fixed "H" after transmit-end.

Transmission cannot be performed while the ORER bit in the SSSR register is set to 1 (overrun error). Confirm that the ORER bit is set to 0 before transmission.

Figure 16.14 shows a Sample Flowchart of Data Transmission (Clock Synchronous Communication Mode).

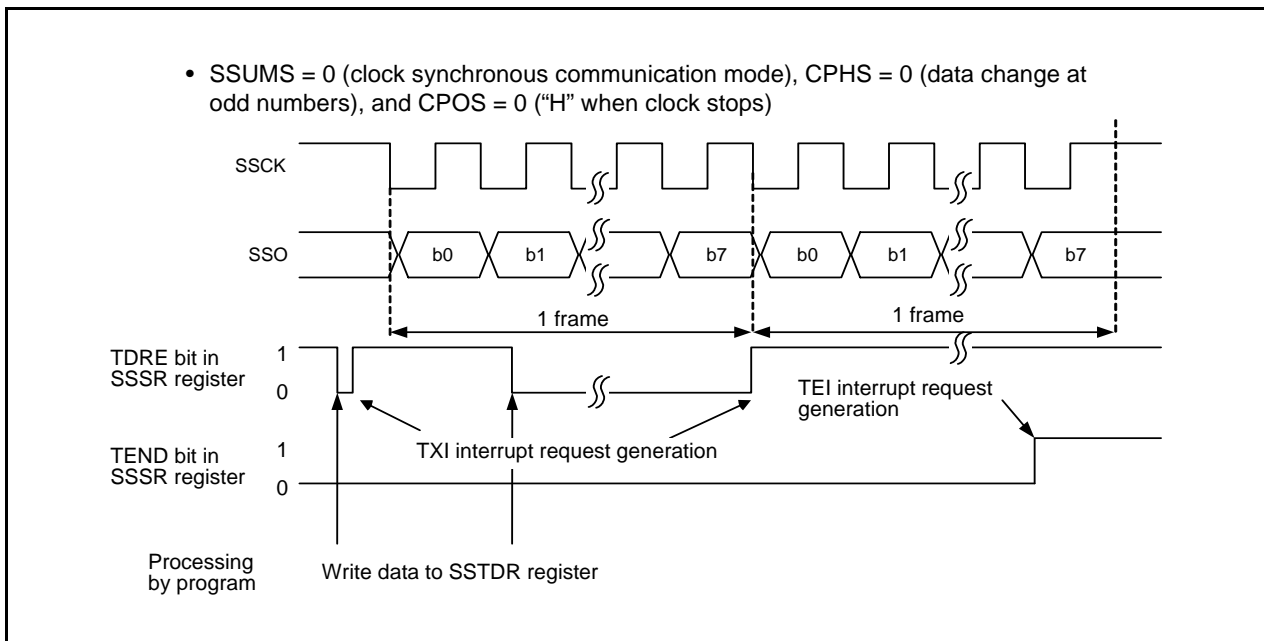

Figure 16.13 Example of Clock Synchronous Serial I/O with Chip Select Operation for Data Transmission (Clock Synchronous Communication Mode)

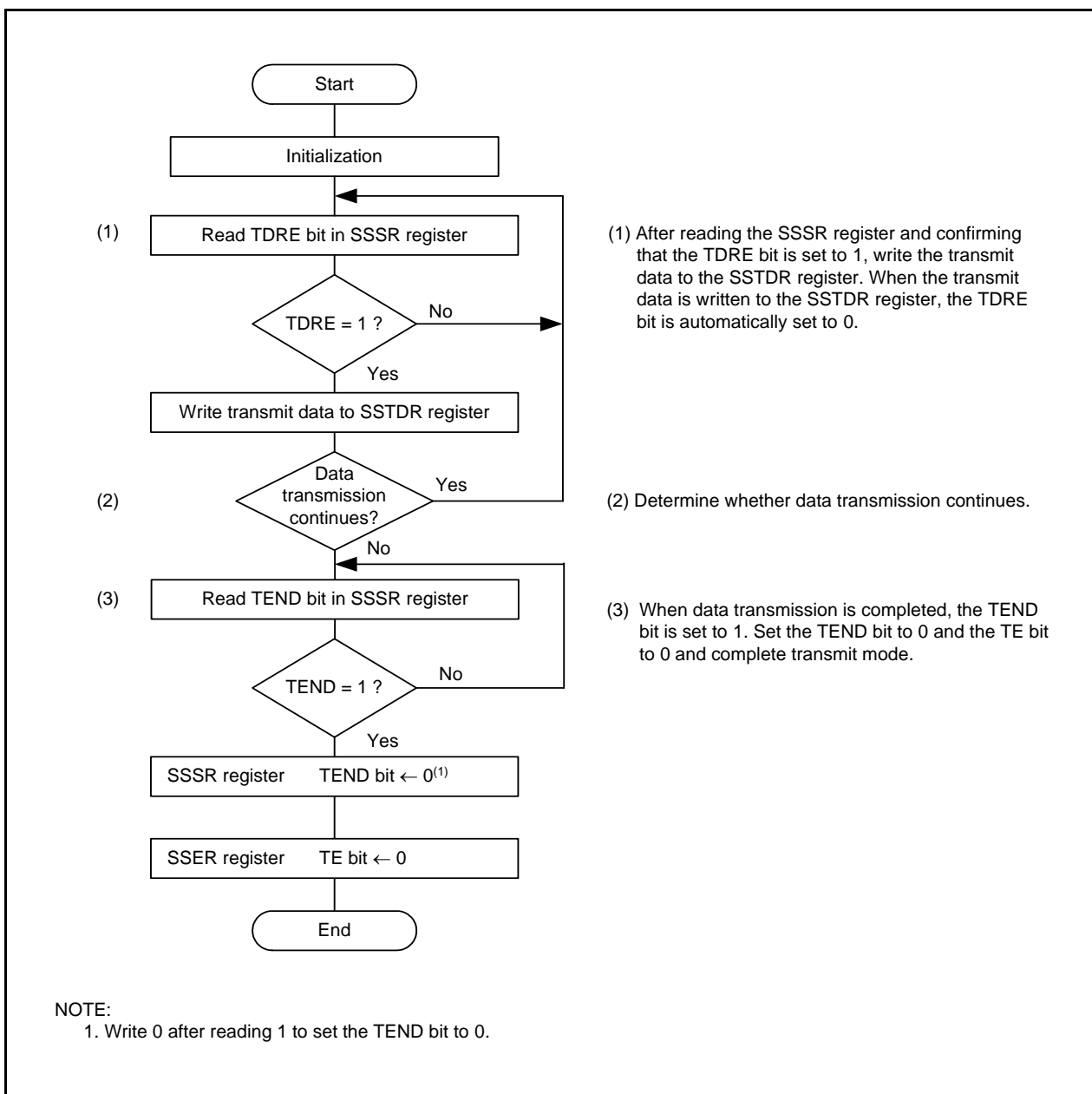

Figure 16.14 Sample Flowchart of Data Transmission (Clock Synchronous Communication Mode)

16.2.5.3 Data Reception

Figure 16.15 shows an Example of Clock Synchronous Serial I/O with Chip Select Operation for Data Reception (Clock Synchronous Communication Mode).

During data reception, clock synchronous serial I/O with chip select operates as described below. When the clock synchronous serial I/O with chip select is set as the master device, it outputs a synchronous clock and inputs data. When clock synchronous serial I/O with chip select is set as a slave device, it inputs data synchronized with the input clock.

When clock synchronous serial I/O with chip select is set as a master device, it outputs a receive clock and starts receiving by performing dummy read of the SSRDR register.

After 8 bits of data are received, the RDRF bit in the SSSR register is set to 1 (data in the SSRDR register) and receive data is stored in the SSRDR register. When the RIE bit in the SSER register is set to 1 (RXI and OEI interrupt requests enabled), the RXI interrupt request is generated. If the SSRDR register is read, the RDRF bit is automatically set to 0 (no data in the SSRDR register).

Read the receive data after setting the RSSTP bit in the SSCRH register to 1 (after receiving 1 byte of data, the receive operation is completed). Clock synchronous serial I/O with chip select outputs a clock for receiving 8 bits of data and stops. After that, set the RE bit in the SSER register to 0 (receive disabled) and the RSSTP bit to 0 (receive operation is continued after receiving the 1 byte of data) and read the receive data. If the SSRDR register is read while the RE bit is set to 1 (receive enabled), a receive clock is output again.

When the 8th clock rises while the RDRF bit is set to 1, the ORER bit in the SSSR register is set to 1 (overflow error: OEI) and the operation is stopped. When the ORER bit is set to 1, receive cannot be performed. Confirm that the ORER bit is set to 0 before restarting receive.

Figure 16.16 shows a Sample Flowchart of Data Reception (MSS = 1) (Clock Synchronous Communication Mode).

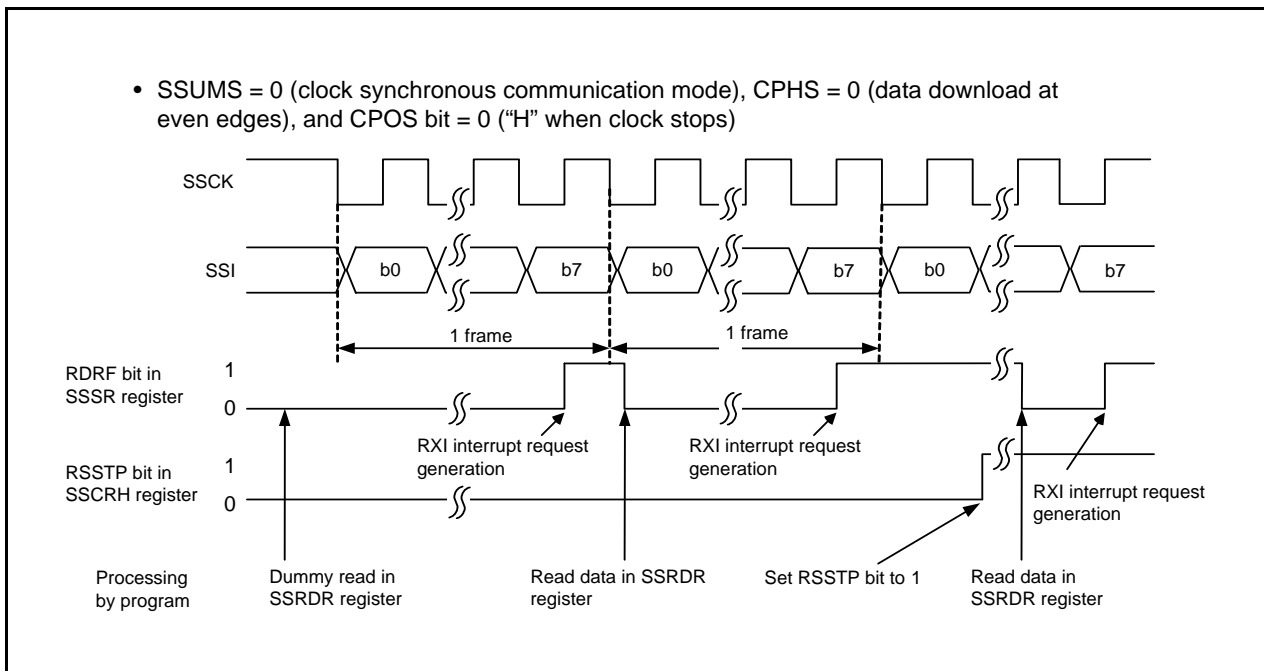

Figure 16.15 Example of Clock Synchronous Serial I/O with Chip Select Operation for Data Reception (Clock Synchronous Communication Mode)

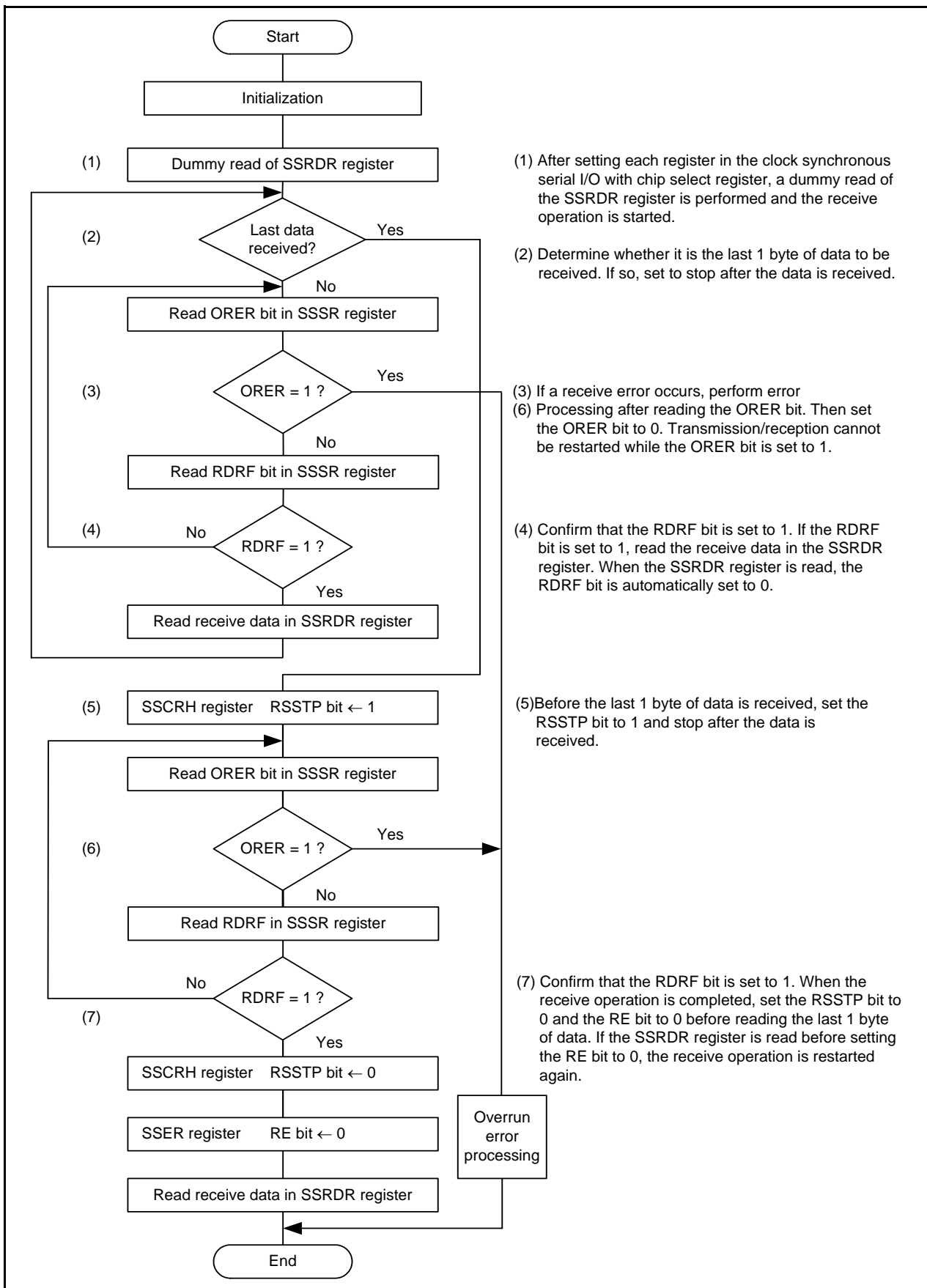

Figure 16.16 Sample Flowchart of Data Reception (MSS = 1) (Clock Synchronous Communication Mode)

16.2.5.4 Data Transmission/Reception

Data transmission/reception is an operation combining data transmission and reception which were described earlier. Transmission/reception is started by writing data to the SSTDR register.

When the 8th clock rises or the ORER bit is set to 1 (overrun error) while the TDRE bit is set to 1 (data is transferred from registers SSTDR to SSTRSR), the transmit/receive operation is stopped.

When switching from transmit mode (TE = 1) or receive mode (RE = 1) to transmit/receive mode (Te = RE = 1), set the TE bit to 0 and RE bit to 0 before switching. After confirming that the TEND bit is set to 0 (the TDRE bit is set to 0 when the last bit of the transmit data is transmitted), the RDRF bit is set to 0 (no data in the SSRDR register), and the ORER bit is set to 0 (no overrun error), set bits TE and RE to 1.

Figure 16.17 shows a Sample Flowchart of Data Transmission/Reception (Clock Synchronous Communication Mode).

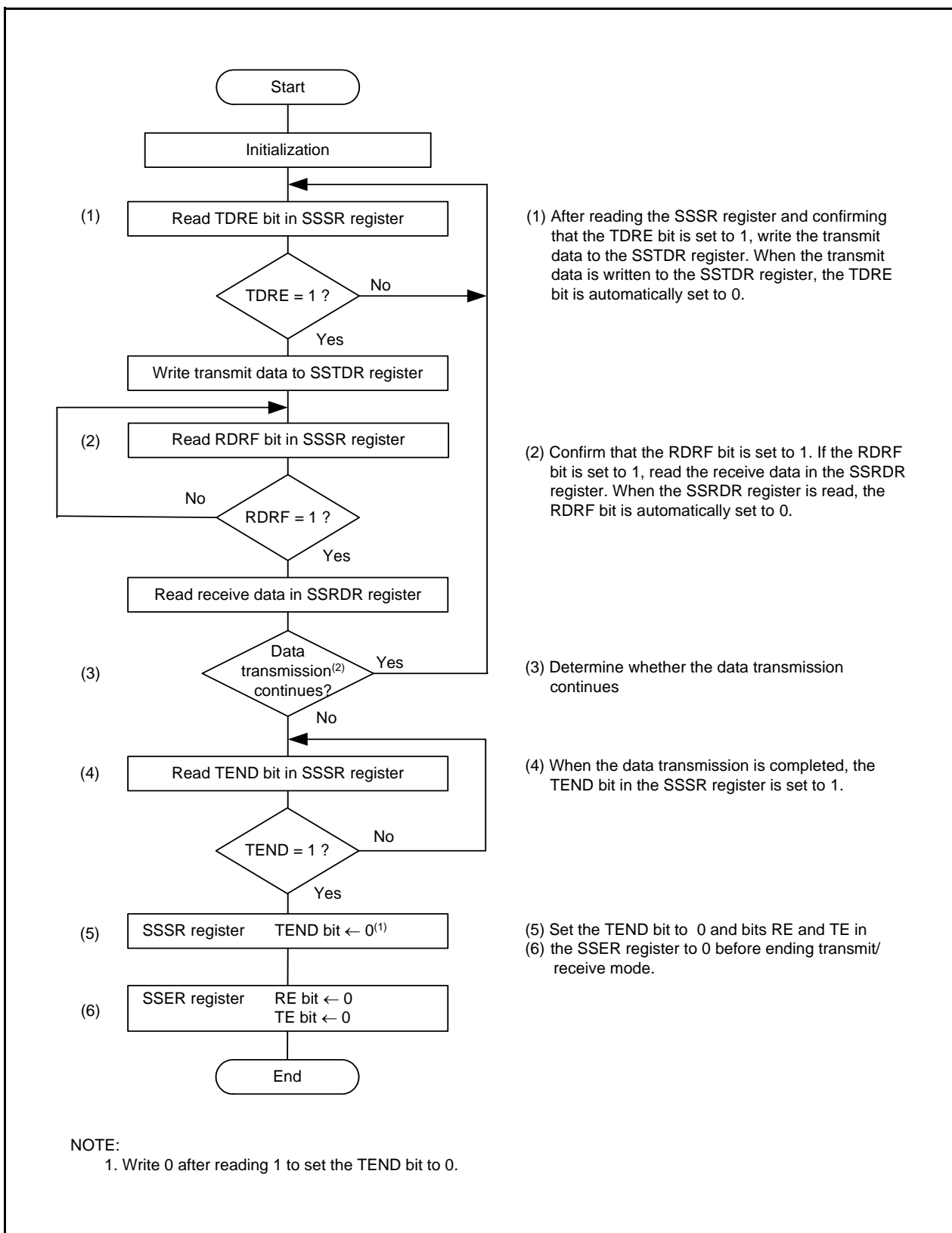

Figure 16.17 Sample Flowchart of Data Transmission/Reception (Clock Synchronous Communication Mode)

16.2.6 Operation in 4-Wire Bus Communication Mode

In 4-wire bus communication mode, a 4-wire bus consisting of a clock line, a data input line, a data output line, and a chip select line is used for communication. This mode includes bidirectional mode in which the data input line and data output line function as a single pin.

The data input line and output line change according to the settings of the MSS bit in the SSCRH register and the BIDE bit in the SSMR2 register. For details, refer to **16.2.2.1 Association between Data I/O Pins and SS Shift Register**. In this mode, clock polarity, phase, and data settings are performed by bits CPOS and CPHS in the SSMR register. For details, refer to **16.2.1.1 Association between Transfer Clock Polarity, Phase, and Data**.

When this MCU is set as the master device, the chip select line controls output. When clock synchronous serial I/O with chip select is set as a slave device, the $\overline{\text{chip}}$ select line controls input. When it is set as the master device, the chip select line controls output of the $\overline{\text{SCS}}$ pin or controls output of a general port according to the setting of the CSS1 bit in the SSMR2 register. When the MCU is set as a slave device, the chip select line sets the $\overline{\text{SCS}}$ pin as an input pin by setting bits CSS1 and CSS0 in the SSMR2 register to 01b.

In 4-wire bus communication mode, the MLS bit in the SSMR register is set to 0 and communication is performed MSB-first.

16.2.6.1 Initialization in 4-Wire Bus Communication Mode

Figure 16.18 shows Initialization in 4-Wire Bus Communication Mode. Before the data transit/receive operation, set the TE bit in the SSER register to 0 (transmit disabled), the RE bit in the SSER register to 0 (receive disabled), and initialize the clock synchronous serial I/O with chip select.

To change the communication mode or format, set the TE bit to 0 and the RE bit to 0 before making the change. Setting the RE bit to 0 does not change the settings of flags RDRF and ORER or the contents of the SSRDR register.

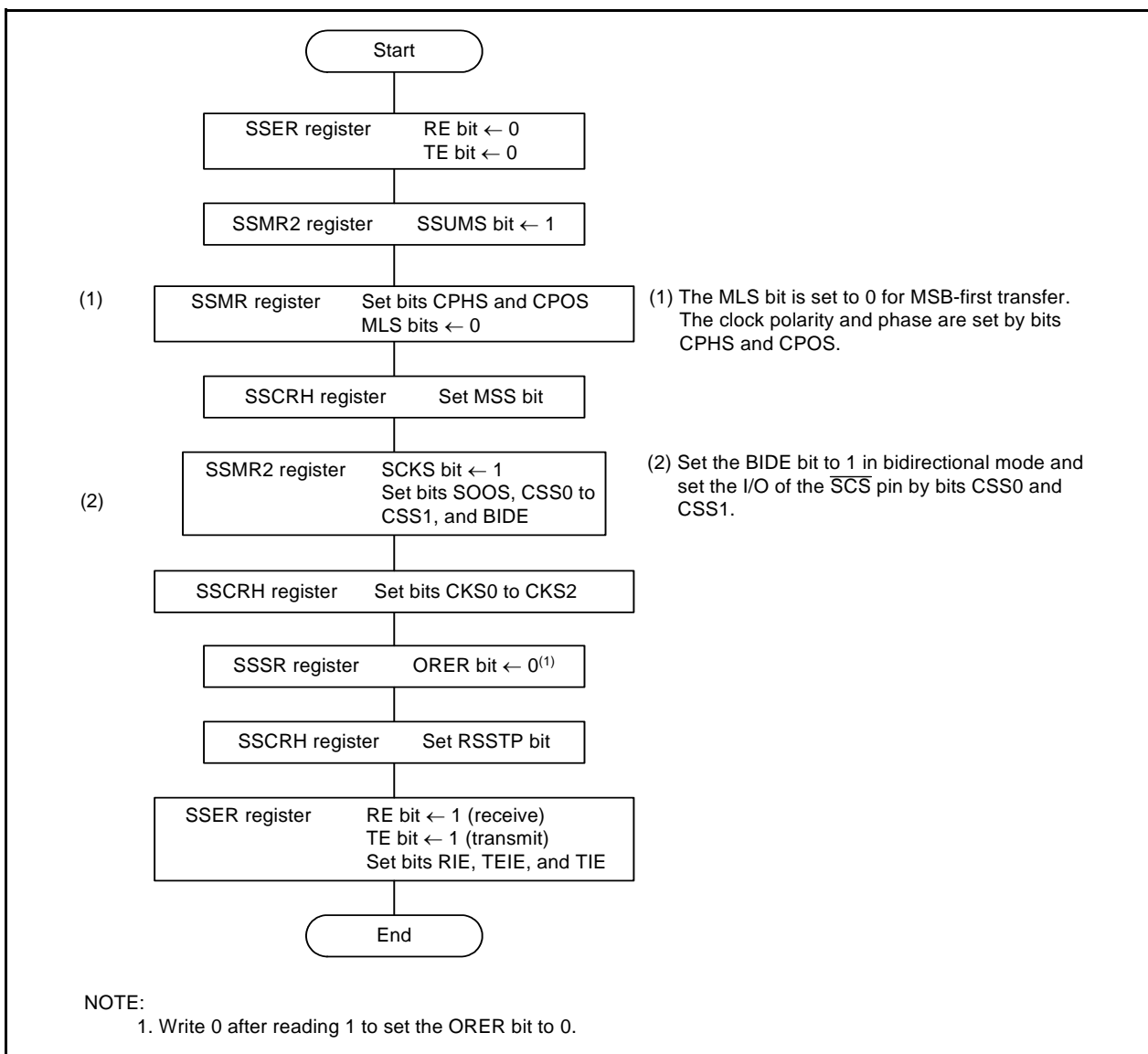

Figure 16.18 Initialization in 4-Wire Bus Communication Mode

16.2.6.2 Data Transmission

Figure 16.19 shows an Example of Clock Synchronous Serial I/O with Chip Select Operation during Data Transmission (4-Wire Bus Communication Mode). During the data transmit operation, clock synchronous serial I/O with chip select operates as described below.

When the MCU is set as the master device, it outputs a synchronous clock and data. When the MCU is set as a slave device, it outputs data in synchronization with the input clock while the \overline{SCS} pin is "L".

When the transmit data is written to the SSTDR register after setting the TE bit to 1 (transmit enabled), the TDRE bit is automatically set to 0 (data has not been transferred from registers SSTDR to SSTRSR) and the data is transferred from registers SSTDR to SSTRSR. After the TDRE bit is set to 1 (data is transferred from registers SSTDR to SSTRSR), transmission starts. When the TIE bit in the SSER register is set to 1, a TXI interrupt request is generated.

After 1 frame of data is transferred while the TDRE bit is set to 0, the data is transferred from registers SSTDR to SSTRSR and transmission of the next frame is started. If the 8th bit is transmitted while TDRE is set to 1, TEND in the SSSR register is set to 1 (when the last bit of the transmit data is transmitted, the TDRE bit is set to 1) and the state is retained. If the TEIE bit in the SSER register is set to 1 (transmit-end interrupt requests enabled), a TEI interrupt request is generated. The SSCK pin remains "H" after transmit-end and the \overline{SCS} pin is held "H". When transmitting continuously while the \overline{SCS} pin is held "L", write the next transmit data to the SSTDR register before transmitting the 8th bit.

Transmission cannot be performed while the ORER bit in the SSSR register is set to 1 (overrun error). Confirm that the ORER bit is set to 0 before transmission.

In contrast to the clock synchronous communication mode, the SSO pin is placed in high-impedance state while the \overline{SCS} pin is placed in high-impedance state when operating as a master device and the SSI pin is placed in high-impedance state while the \overline{SCS} pin is placed in "H" input state when operating as a slave device.

The sample flowchart is the same as that for the clock synchronous communication mode (refer to **Figure 16.14 Sample Flowchart of Data Transmission (Clock Synchronous Communication Mode)**).

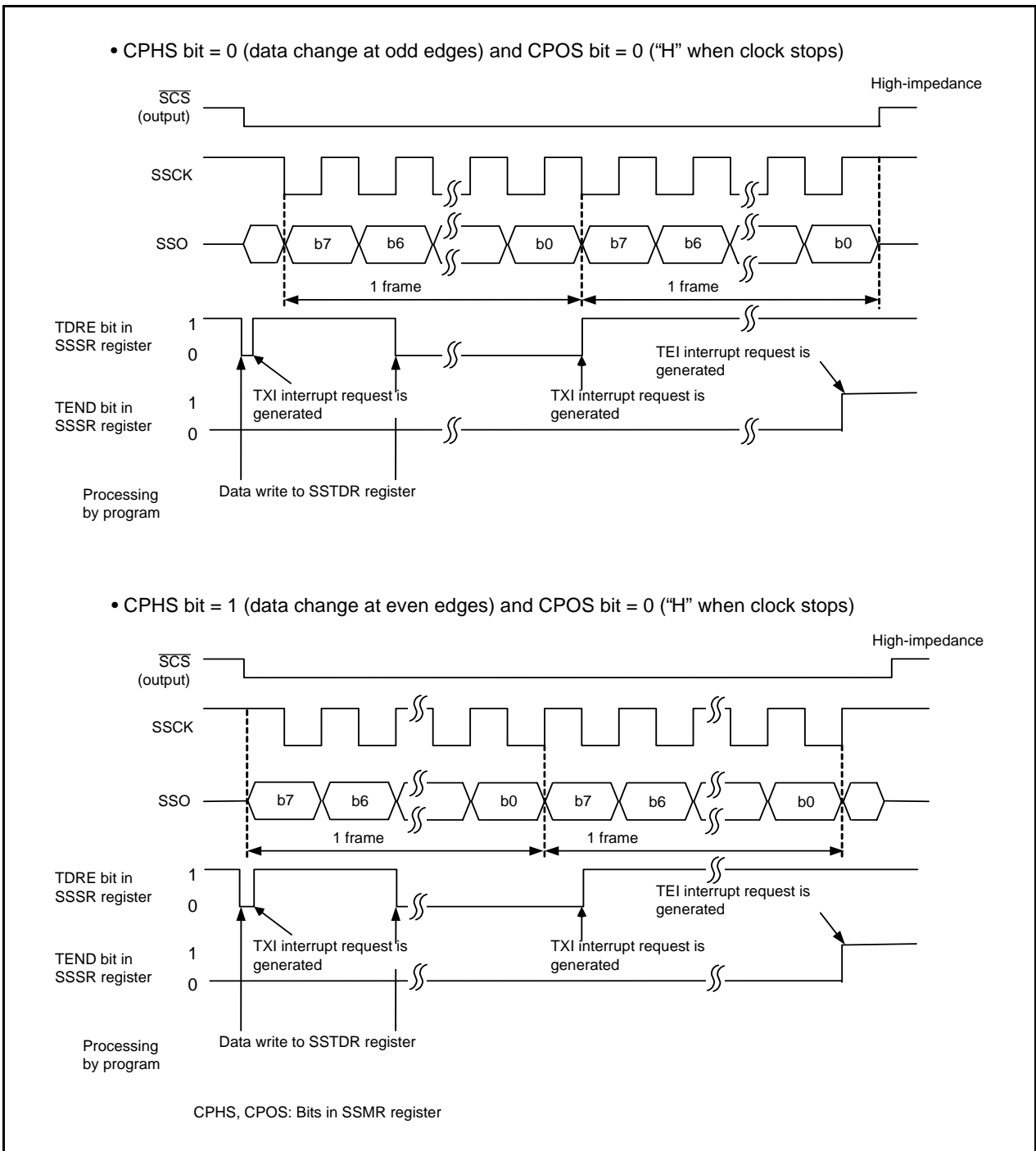

Figure 16.19 Example of Clock Synchronous Serial I/O with Chip Select Operation during Data Transmission (4-Wire Bus Communication Mode)

16.2.6.3 Data Reception

Figure 16.20 shows an example of clock synchronous serial I/O with chip select operation (4-wire bus communication mode) for data reception. During data reception, clock synchronous serial I/O with chip select operates as described below.

When the MCU is set as the master device, it outputs a synchronous clock and inputs data. When the MCU is set as a slave device, it outputs data synchronized with the input clock while the \overline{SCS} pin receives “L” input. When the MCU is set as the master device, it outputs a receive clock and starts receiving by performing a dummy read of the SSRDR register.

After 8 bits of data are received, the RDRF bit in the SSSR register is set to 1 (data in the SSRDR register) and receive data is stored in the SSRDR register. When the RIE bit in the SSER register is set to 1 (RXI and OEI interrupt requests enabled), an RXI interrupt request is generated. When the SSRDR register is read, the RDRF bit is automatically set to 0 (no data in the SSRDR register).

Read the receive data after setting the RSSTP bit in the SSCRH register to 1 (after receiving 1-byte data, the receive operation is completed). Clock synchronous serial I/O with chip select outputs a clock for receiving 8 bits of data and stops. After that, set the RE bit in the SSER register to 0 (receive disabled) and the RSSTP bit to 0 (receive operation is continued after receiving 1-byte data) and read the receive data. When the SSRDR register is read while the RE bit is set to 1 (receive enabled), a receive clock is output again.

When the 8th clock rises while the RDRF bit is set to 1, the ORER bit in the SSSR register is set to 1 (overrun error: OEI) and the operation is stopped. When the ORER bit is set to 1, reception cannot be performed. Confirm that the ORER bit is set to 0 before restarting reception.

The timing with which bits RDRF and ORER are set to 1 varies depending on the setting of the CPHS bit in the SSMR register. Figure 16.20 shows when bits RDRF and ORER are set to 1.

When the CPHS bit is set to 1 (data download at the odd edges), bits RDRF and ORER are set to 1 at some point during the frame.

The sample flowchart is the same as that for the clock synchronous communication mode (refer to **Figure 16.16 Sample Flowchart of Data Reception (MSS = 1) (Clock Synchronous Communication Mode)**).

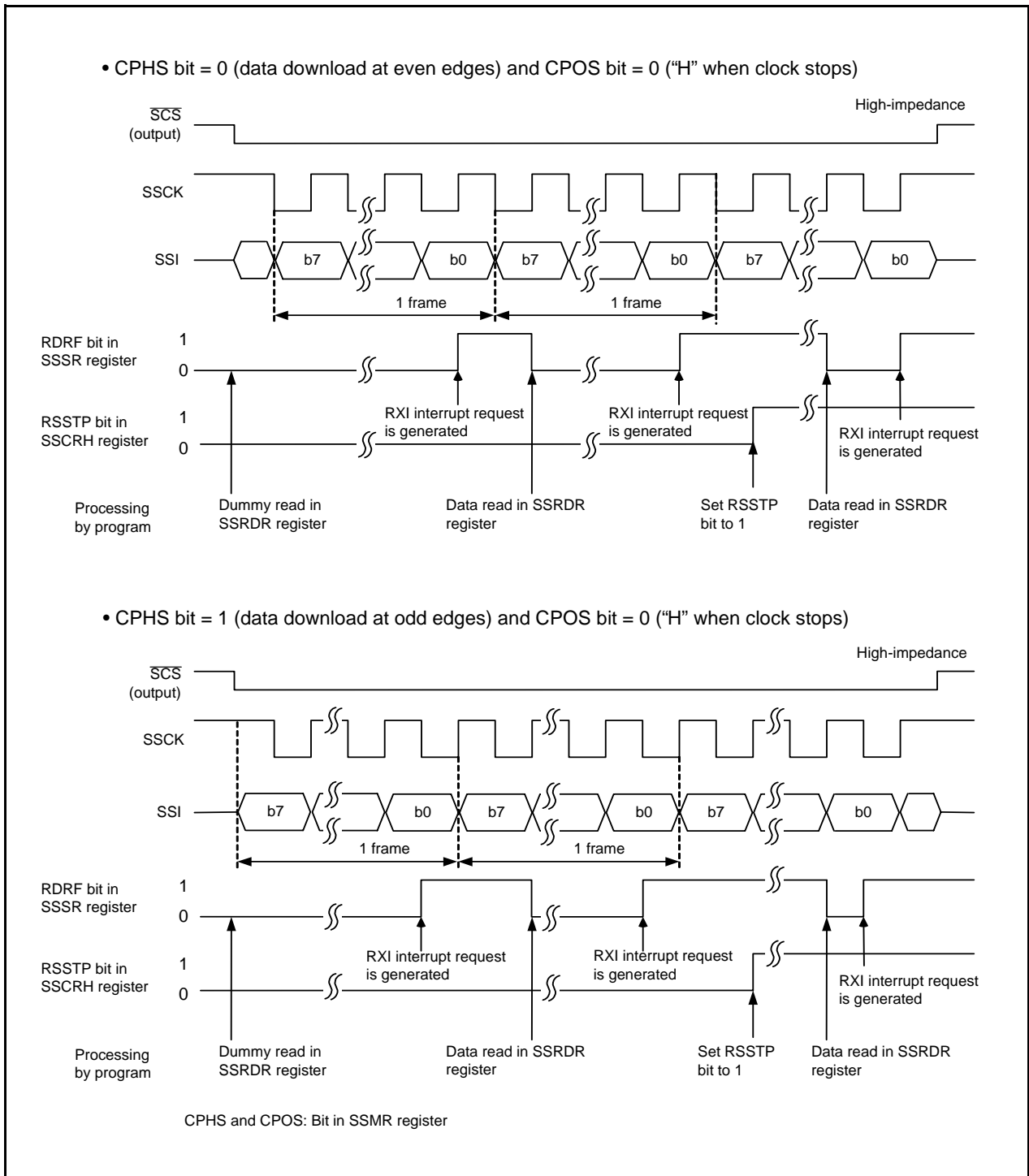

Figure 16.20 Example of Clock Synchronous Serial I/O with Chip Select Operation during Data Reception (4-Wire Bus Communication Mode)

16.2.7 \overline{SCS} Pin Control and Arbitration

When setting the SSUMS bit in the SSMR2 register to 1 (4-wire bus communication mode) and the CSS1 bit in the SSMR2 register to 1 (functions as \overline{SCS} output pin), set the MSS bit in the SSCRH register to 1 (operates as the master device) and check the arbitration of the \overline{SCS} pin before starting serial transfer. If clock synchronous serial I/O with chip select detects that the synchronized internal \overline{SCS} signal is held "L" in this period, the CE bit in the SSSR register is set to 1 (conflict error) and the MSS bit is automatically set to 0 (operates as a slave device).

Figure 16.21 shows the Arbitration Check Timing.

Future transmit operations are not performed while the CE bit is set to 1. Set the CE bit to 0 (no conflict error) before starting transmission.

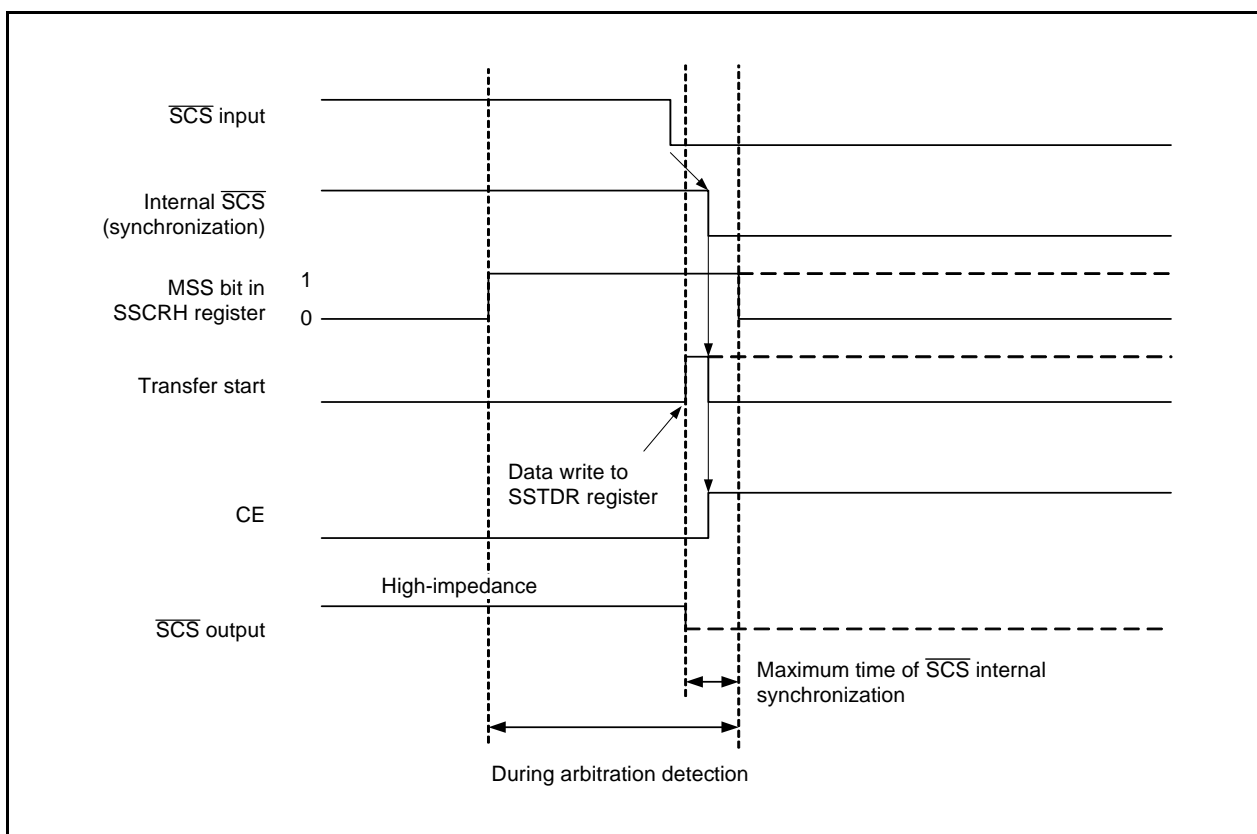

Figure 16.21 Arbitration Check Timing

16.2.8 Notes on Clock Synchronous Serial I/O with Chip Select

Set the IICSEL bit in the PMR register to 0 (select clock synchronous serial I/O with chip select function) to use the clock synchronous serial I/O with chip select function.

16.2.8.1 Accessing Registers Associated with Clock Synchronous Serial I/O with Chip Select

After waiting three instructions or more after writing to the registers associated with clock synchronous serial I/O with chip select (00B8h to 00BFh) or four cycles or more after writing to them, read the registers.

- An example of waiting three instructions or more

```

Program example      MOV.B      #00h,00BBh      ; Set the SSER register to 00h.
                    NOP
                    NOP
                    NOP
                    MOV.B      00BBh,R0L
  
```

- An example of waiting four cycles or more

```

Program example      BCLR      4,00BBh      : Disable transmission
                    JMP.B      NEXT
NEXT:
                    BSET      3,00BBh      : Enable reception
  
```

16.3 I²C bus Interface

The I²C bus interface is the circuit that performs serial communication based on the data transfer format of the Philips I²C bus.

Table 16.5 lists the I²C bus Interface Specifications, Figure 16.22 shows a Block Diagram of I²C bus interface, and Figure 16.23 shows the External Circuit Connection Example of Pins SCL and SDA. Figures 16.24 to 16.31 show the registers associated with the I²C bus interface.

* I²C bus is a trademark of Koninklijke Philips Electronics N. V.

Table 16.5 I²C bus Interface Specifications

Item	Specification
Communication formats	<ul style="list-style-type: none"> • I²C bus format <ul style="list-style-type: none"> - Selectable as master/slave device - Continuous transmit/receive operation (because the shift register, transmit data register, and receive data register are independent) - Start/stop conditions are automatically generated in master mode - Automatic loading of acknowledge bit during transmission - Bit synchronization/wait function (In master mode, the state of the SCL signal is monitored per bit and the timing is synchronized automatically. If the transfer is not possible yet, the SCL signal goes "L" and the interface stands by.) - Support for direct drive of pins SCL and SDA (N-channel open drain output) • Clock synchronous serial format <ul style="list-style-type: none"> - Continuous transmit/receive operation (because the shift register, transmit data register, and receive data register are independent)
I/O pins	SCL (I/O): Serial clock I/O pin SDA (I/O): Serial data I/O pin
Transfer clocks	<ul style="list-style-type: none"> • When the MST bit in the ICCR1 register is set to 0 The external clock (input from the SCL pin) • When the MST bit in the ICCR1 register is set to 1 The internal clock selected by bits CKS0 to CKS3 in the ICCR1 register (output from the SCL pin)
Receive error detection	<ul style="list-style-type: none"> • Overrun error detection (clock synchronous serial format) Indicates an overrun error during reception. When the last bit of the next data item is received while the RDRF bit in the ICSR register is set to 1 (data in the ICDRR register), the AL bit is set to 1.
Interrupt sources	<ul style="list-style-type: none"> • I²C bus format 6 sources⁽¹⁾ Transmit data empty (including when slave address matches), transmit ends, receive data full (including when slave address matches), arbitration lost, NACK detection, and stop condition detection. • Clock synchronous serial format 4 sources⁽¹⁾ Transmit data empty, transmit ends, receive data full and overrun error
Select functions	<ul style="list-style-type: none"> • I²C bus format <ul style="list-style-type: none"> - Selectable output level for acknowledge signal during reception • Clock synchronous serial format <ul style="list-style-type: none"> - MSB-first or LSB-first selectable as data transfer direction

NOTE:

1. All sources use one interrupt vector for I²C bus interface.

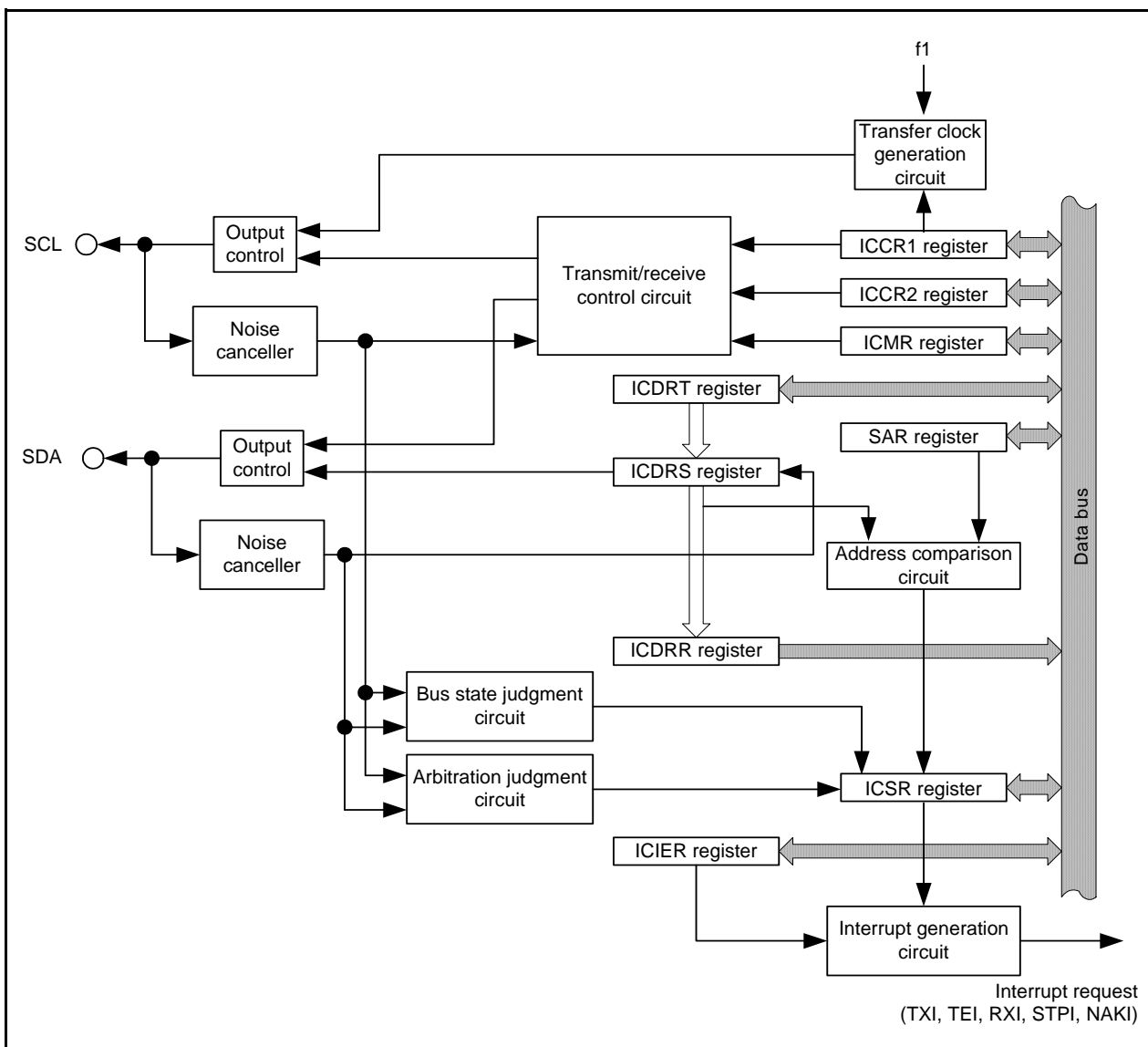

Figure 16.22 Block Diagram of I²C bus interface

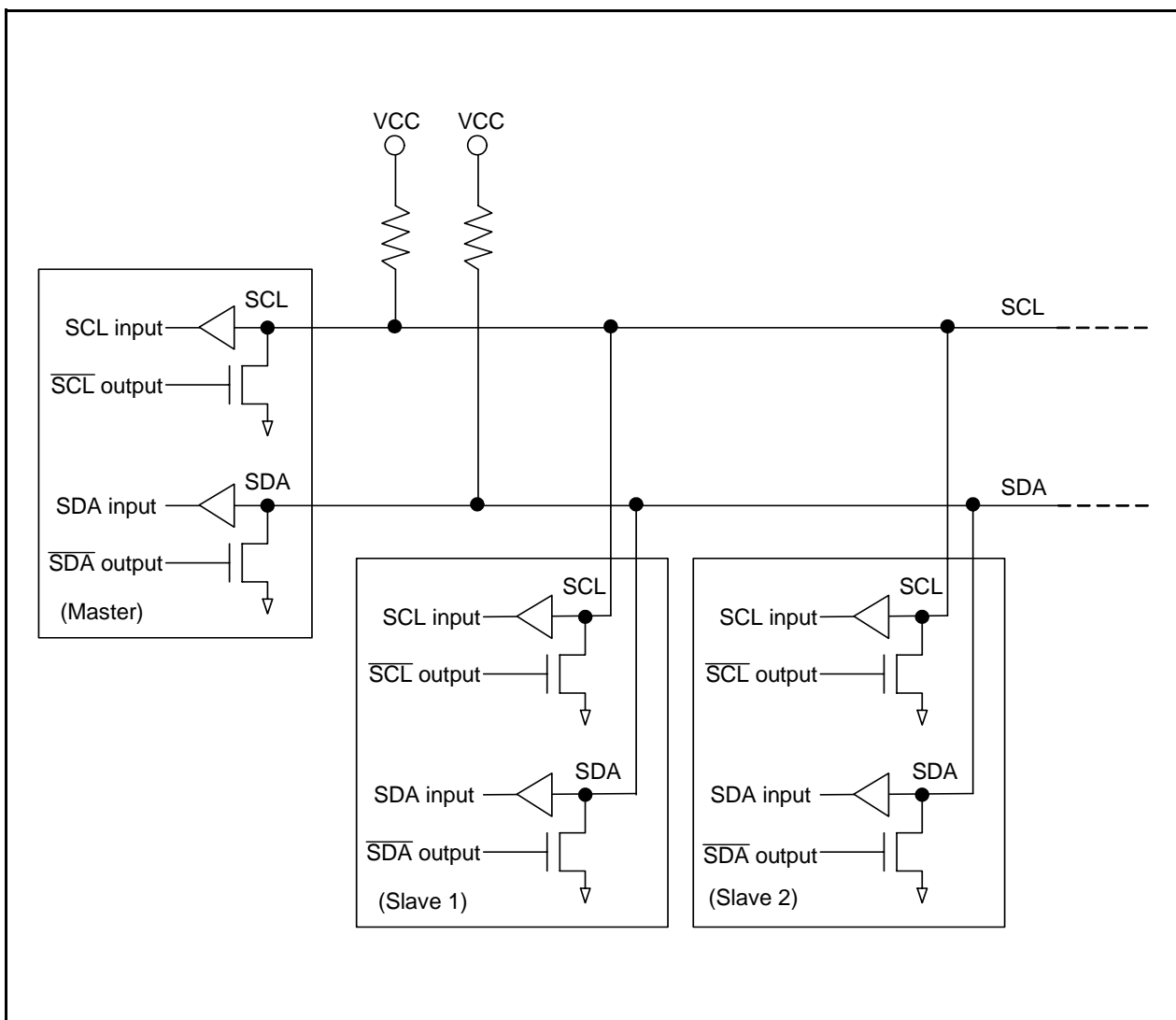

Figure 16.23 External Circuit Connection Example of Pins SCL and SDA

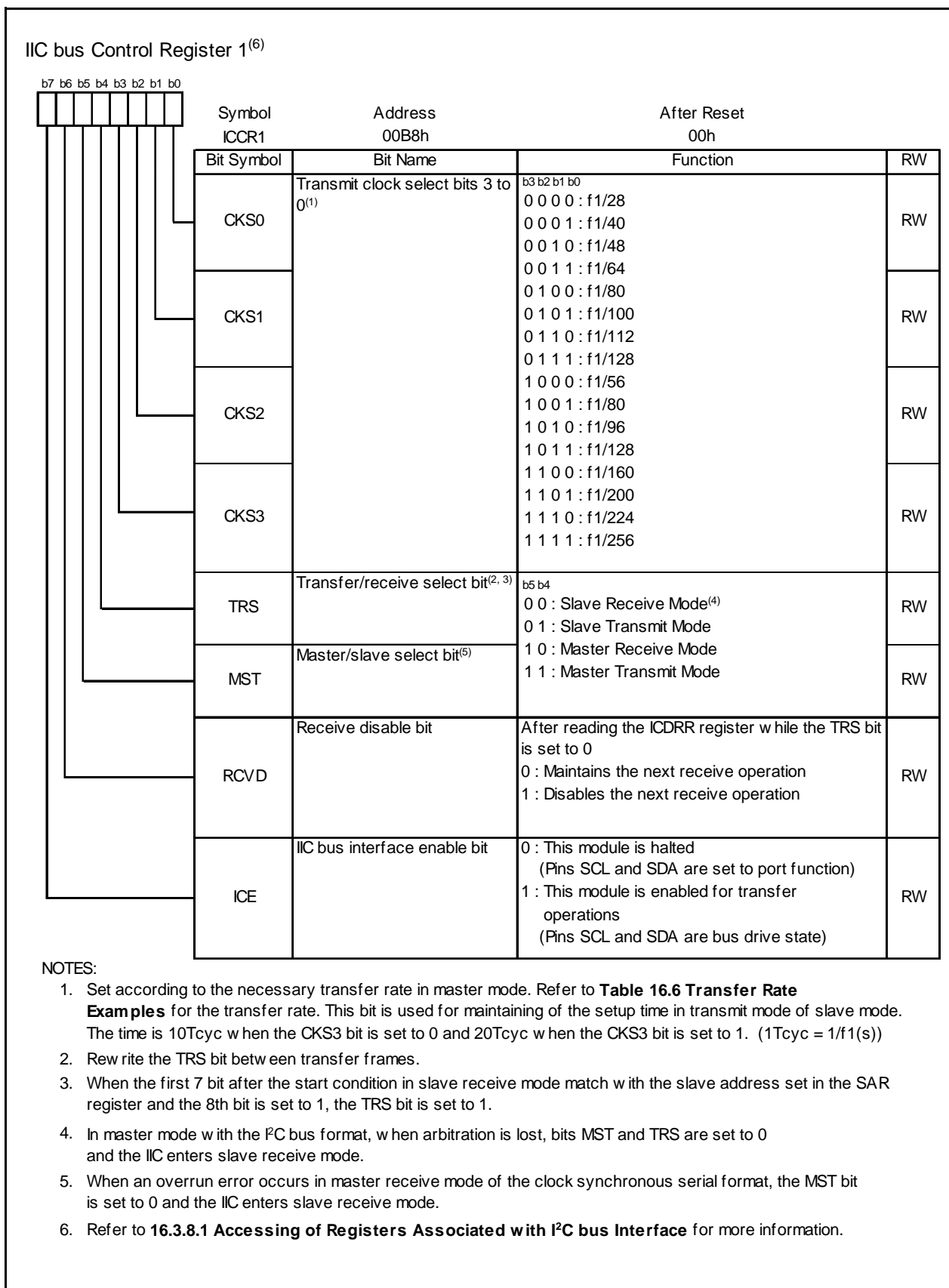

Figure 16.24 ICCR1 Register

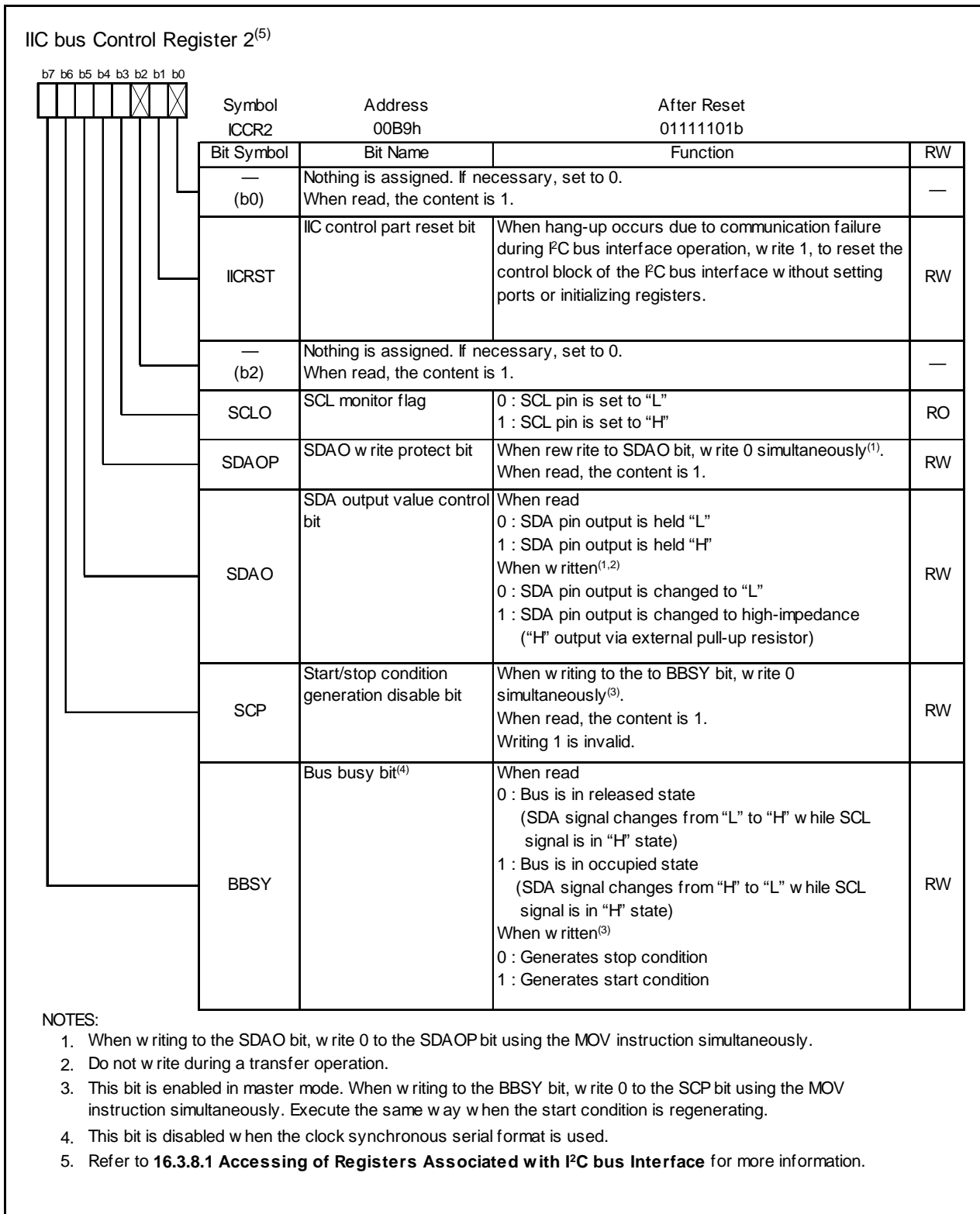

Figure 16.25 ICCR2 Register

IIC bus Mode Register ⁽⁷⁾					
b7 b6 b5 b4 b3 b2 b1 b0					
		Symbol ICMR	Address 00BAh	After Reset 00011000b	
Bit Symbol	Bit Name	Function	RW		
BC0	Bits counter 2 to 0	I ² C bus format (remaining transfer bit count when read out and data bit count of next transfer when written) ^(1,2) . b2 b1 b0 0 0 0 : 9 bits ⁽³⁾ 0 0 1 : 2 bits 0 1 0 : 3 bits 0 1 1 : 4 bits 1 0 0 : 5 bits 1 0 1 : 6 bits 1 1 0 : 7 bits 1 1 1 : 8 bits	RW		
			BC1	Clock synchronous serial format (when read, the remaining transfer bit count and when written 000b). b2 b1 b0 0 0 0 : 8 bits 0 0 1 : 1 bit 0 1 0 : 2 bits 0 1 1 : 3 bits 1 0 0 : 4 bits 1 0 1 : 5 bits 1 1 0 : 6 bits 1 1 1 : 7 bits	RW
					BC2
BCWP	BC write protect bit	When rewriting bits BC0 to BC2, write 0 simultaneously ^(2,4) . When read, the content is 1.	RW		
— (b4)	Nothing is assigned. If necessary, set to 0. When read, the content is 1.		—		
— (b5)	Reserved bit	Set to 0.	RW		
WAIT	Wait insertion bit ⁽⁵⁾	0 : No wait (Transfer data and acknowledge bit consecutively) 1 : Wait (After the clock falls for the final data bit, "L" period is extended for two transfer clocks cycles)	RW		
MLS	MSB-first/LSB-first select bit	0 : Data transfer with MSB-first ⁽⁶⁾ 1 : Data transfer with LSB-first	RW		

NOTES:

1. Rewrite between transfer frames. When writing values other than 000b, write when the SCL signal is "L".
2. When writing to bits BC0 to BC2, write 0 to the BCWP bit using the MOV instruction.
3. After data including the acknowledge bit is transferred, these bits are automatically set to 000b. When the start condition is detected, these bits are automatically set to 000b.
4. Do not rewrite when the clock synchronous serial format is used.
5. The setting value is enabled in master mode of the I²C bus format. It is disabled in slave mode of the I²C bus format or when the clock synchronous serial format is used.
6. Set to 0 when the I²C bus format is used.
7. Refer to **16.3.8.1 Accessing of Registers Associated with I²C bus Interface** for more information.

Figure 16.26 ICMR Register

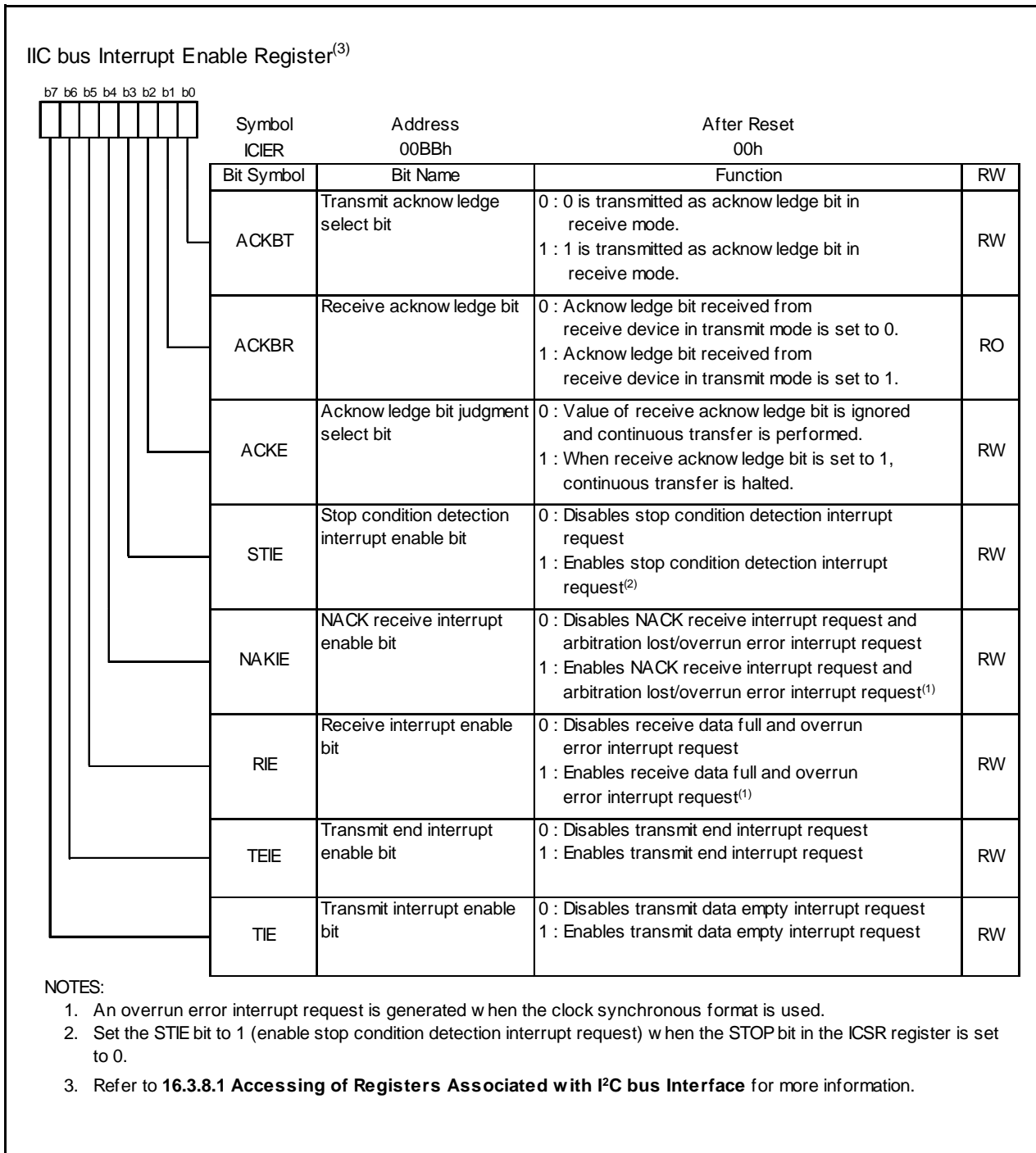

Figure 16.27 ICIER Register

IIC bus Status Register ⁽⁷⁾			
b7 b6 b5 b4 b3 b2 b1 b0			
Symbol	Address	After Reset	
ICSR	00BCh	0000X000b	
Bit Symbol	Bit Name	Function	RW
ADZ	General call address recognition flag ^(1,2)	When the general call address is detected, this flag is set to 1.	RW
AAS	Slave address recognition flag ⁽¹⁾	This flag is set to 1 when the first frame following start condition matches bits SVA0 to SVA6 in the SAR register in slave receive mode. (Detect the slave address and generate call address)	RW
AL	Arbitration lost flag/overflow error flag ⁽¹⁾	When the I ² C bus format is used, this flag indicates that arbitration has been lost in master mode. In the following cases, this flag is set to 1 ⁽³⁾ . <ul style="list-style-type: none"> When the internal SDA signal and SDA pin level do not match at the rise of the SCL signal in master transmit mode When the start condition is detected and the SDA pin is held "H" in master transmit/receive mode This flag indicates an overrun error when the clock synchronous format is used. In the following case, this flag is set to 1. <ul style="list-style-type: none"> When the last bit of the next data item is received while the RDRF bit is set to 1 	RW
STOP	Stop condition detection flag ⁽¹⁾	When the stop condition is detected after the frame is transferred, this flag is set to 1.	RW
NACKF	No acknowledge detection flag ^(1,4)	When no ACKnowledge is detected from the receive device after transmission, this flag is set to 1.	RW
RDRF	Receive data register full ^(1,5)	When receive data is transferred from registers ICDRS to ICDRR, this flag is set to 1.	RW
TEND	Transmit end ^(1,6)	When the 9th clock cycle of the SCL signal in the I ² C bus format occurs while the TDRE bit is set to 1, this flag is set to 1. This flag is set to 1 when the final bit of the transmit frame is transmitted in the clock synchronous format.	RW
TDRE	Transmit data empty ^(1,6)	In the following cases, this flag is set to 1. <ul style="list-style-type: none"> Data is transferred from registers ICRT to ICDRS and the ICRT register is empty When setting the TRS bit in the ICCR1 register to 1 (transmit mode) When generating the start condition (including retransmit) When changing from slave receive mode to slave transmit mode 	RW

NOTES:

- Each bit is set to 0 by reading 1 before writing 0.
- This flag is enabled in slave receive mode of the I²C bus format.
- When two or more master devices attempt to occupy the bus at nearly the same time, if the I²C bus Interface monitors the SDA pin and the data which the I²C bus Interface transmits is different, the AL flag is set to 1 and the bus is occupied by another master.
- The NACKF bit is enabled when the ACKE bit in the ICIE register is set to 1 (when the receive acknowledge bit is set to 1, transfer is halted).
- The RDRF bit is set to 0 when reading data from the ICDRR register.
- Bits TEND and TDRE are set to 0 when writing data to the ICRT register.
- Refer to **16.3.8.1 Accessing of Registers Associated with I²C bus Interface** for more information.

Figure 16.28 ICSR Register

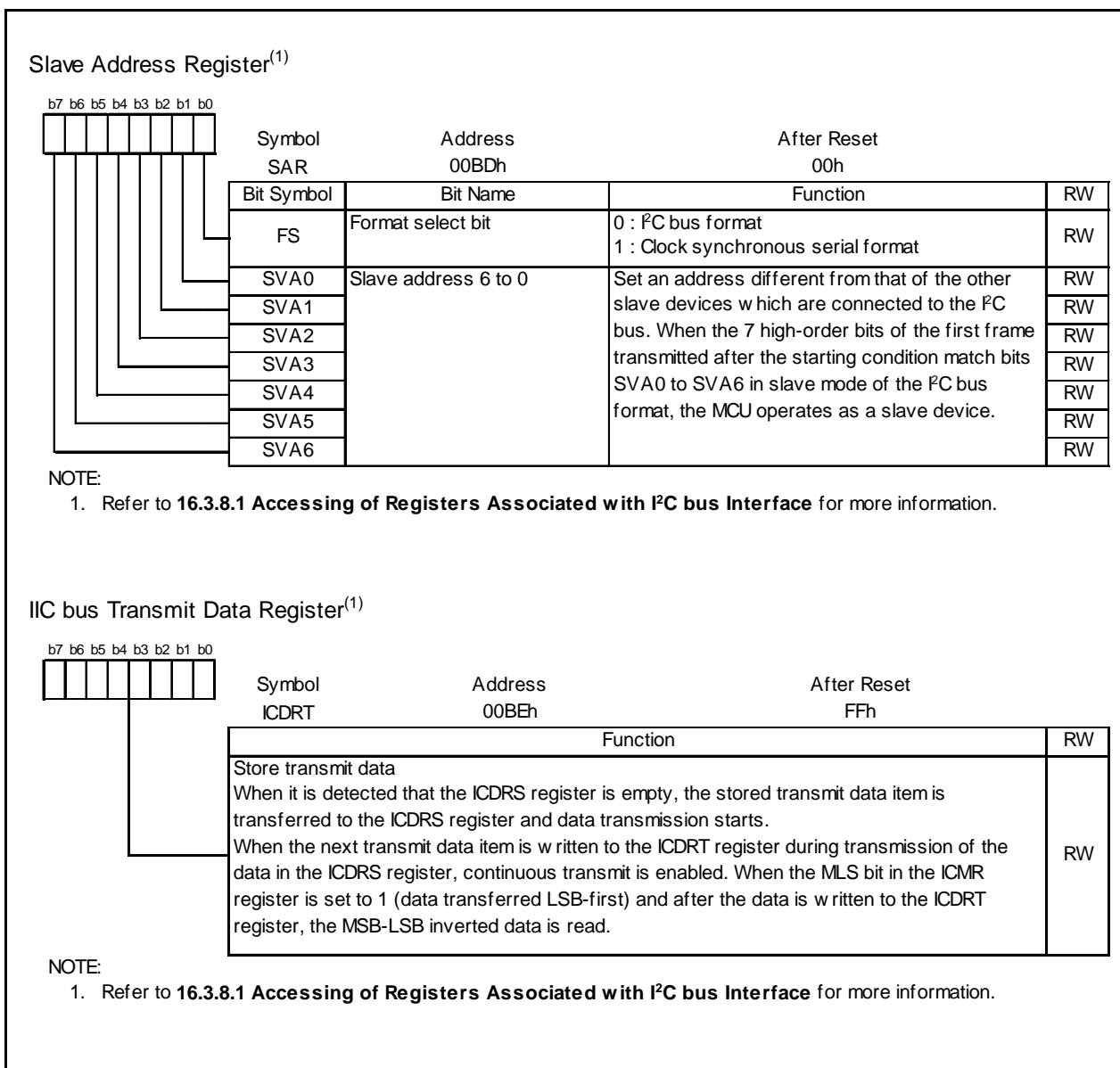

Figure 16.29 Registers SAR and ICDRT

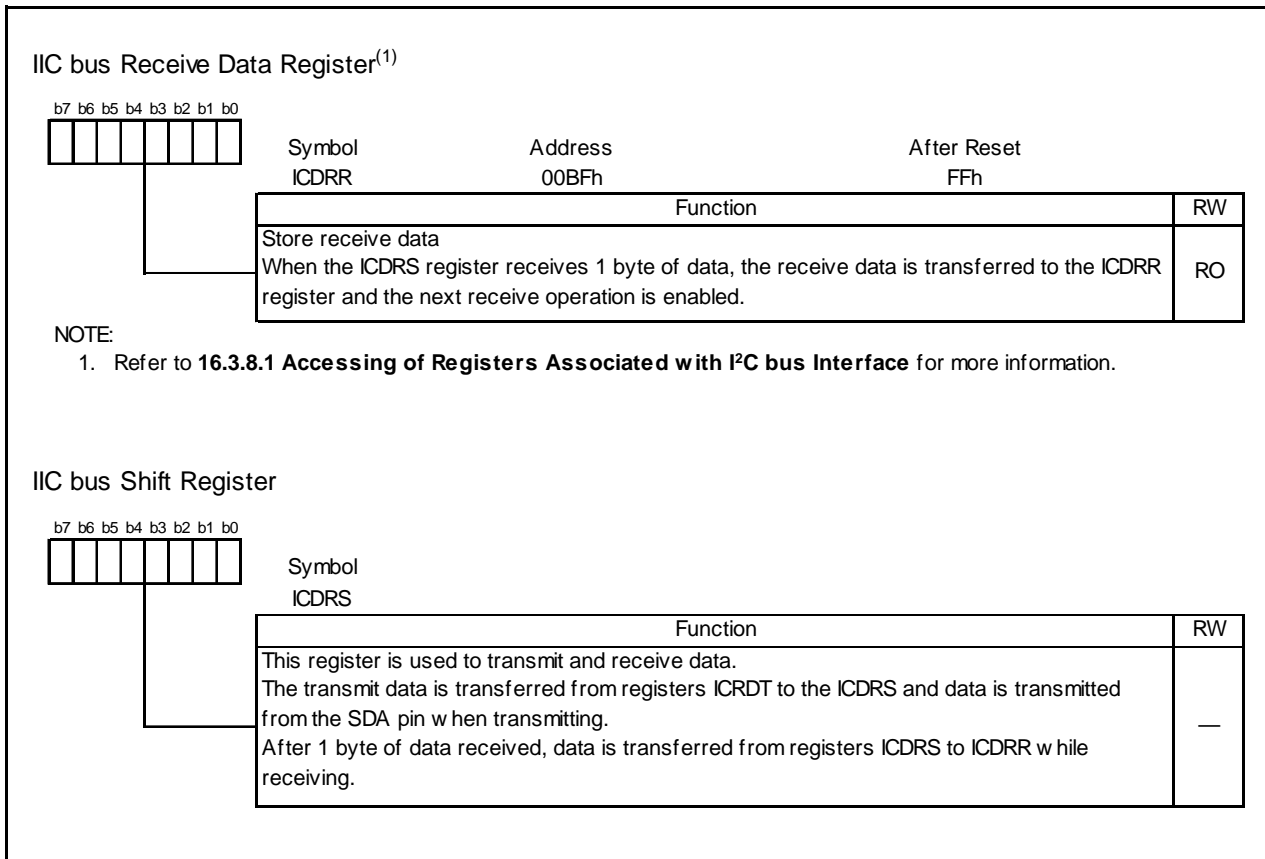

Figure 16.30 Registers ICDRR and ICDRS

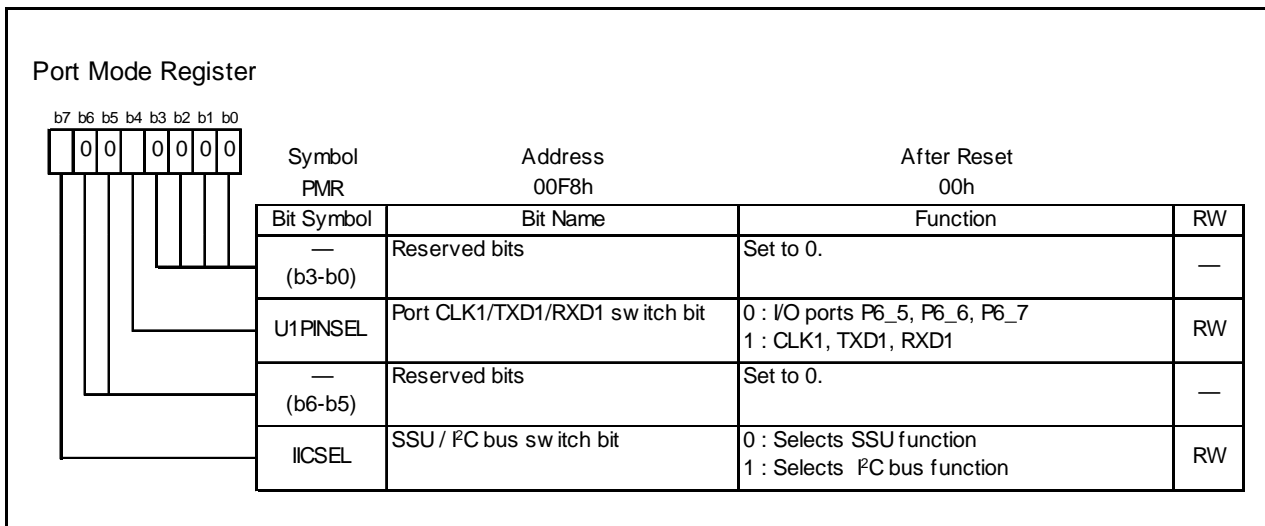

Figure 16.31 PMR Register

16.3.1 Transfer Clock

When the MST bit in the ICCR1 register is set to 0, the transfer clock is the external clock input from the SCL pin. When the MST bit in the ICCR1 register is set to 1, the transfer clock is the internal clock selected by bits CKS0 to CKS3 in the ICCR1 register and the transfer clock is output from the SCL pin.

Table 16.6 lists the Transfer Rate Examples.

Table 16.6 Transfer Rate Examples

ICCR1 Register				Transfer Clock	Transfer Rate				
CKS 3	CKS 2	CKS 1	CKS 0		f1 = 5 MHz	f1 = 8 MHz	f1 = 10 MHz	f1 = 16 MHz	f1 = 20 MHz
0	0	0	0	f1/28	179 kHz	286 kHz	357 kHz	571 kHz	714 kHz
			1	f1/40	125 kHz	200 kHz	250 kHz	400 kHz	500 kHz
		1	0	f1/48	104 kHz	167 kHz	208 kHz	333 kHz	417 kHz
			1	f1/64	78.1 kHz	125 kHz	156 kHz	250 kHz	313 kHz
	1	0	0	f1/80	62.5 kHz	100 kHz	125 kHz	200 kHz	250 kHz
			1	f1/100	50.0 kHz	80.0 kHz	100 kHz	160 kHz	200 kHz
		1	0	f1/112	44.6 kHz	71.4 kHz	89.3 kHz	143 kHz	179 kHz
			1	f1/128	39.1 kHz	62.5 kHz	78.1 kHz	125 kHz	156 kHz
1	0	0	0	f1/56	89.3 kHz	143 kHz	179 kHz	286 kHz	357 kHz
			1	f1/80	62.5 kHz	100 kHz	125 kHz	200 kHz	250 kHz
		1	0	f1/96	52.1 kHz	83.3 kHz	104 kHz	167 kHz	208 kHz
			1	f1/128	39.1 kHz	62.5 kHz	78.1 kHz	125 kHz	156 kHz
	1	0	0	f1/160	31.3 kHz	50.0 kHz	62.5 kHz	100 kHz	125 kHz
			1	f1/200	25.0 kHz	40.0 kHz	50.0 kHz	80.0 kHz	100 kHz
		1	0	f1/224	22.3 kHz	35.7 kHz	44.6 kHz	71.4 kHz	89.3 kHz
			1	f1/256	19.5 kHz	31.3 kHz	39.1 kHz	62.5 kHz	78.1 kHz

16.3.2 Interrupt Requests

The I²C bus interface has six interrupt requests when the I²C bus format is used and four interrupt requests when the clock synchronous serial format is used.

Table 16.7 lists the Interrupt Requests of I²C bus Interface.

Since these interrupt requests are allocated at the I²C bus interface interrupt vector table, determining the source bit by bit is necessary.

Table 16.7 Interrupt Requests of I²C bus Interface

Interrupt Request		Generation Condition	Format	
			I ² C bus	Clock Synchronous Serial
Transmit data empty	TXI	TIE = 1 and TDRE = 1	Enabled	Enabled
Transmit ends	TEI	TEIE = 1 and TEND = 1	Enabled	Enabled
Receive data full	RXI	RIE = 1 and RDRF = 1	Enabled	Enabled
Stop condition detection	STPI	STIE = 1 and STOP = 1	Enabled	Disabled
NACK detection	NAKI	NAKIE = 1 and AL = 1 (or NAKIE = 1 and NACKF = 1)	Enabled	Disabled
Arbitration lost/overrun error			Enabled	Enabled

STIE, NAKIE, RIE, TEIE, TIE: Bits in ICIER register

AL, STOP, NACKF, RDRF, TEND, TDRE: Bits in ICSR register

When the generation conditions listed in Table 16.7 are met, an I²C bus interface interrupt request is generated. Set the interrupt generation conditions to 0 by the I²C bus interface interrupt routine. However, bits TDRE and TEND are automatically set to 0 by writing transmit data to the ICDRT register and the RDRF bit is automatically set to 0 by reading the ICDRR register. When writing transmit data to the ICDRT register, the TDRE bit is set to 0. When data is transferred from registers ICDRT to ICDRS, the TDRE bit is set to 1 and by further setting the TDRE bit to 0, 1 additional byte may be transmitted.

Set the STIE bit to 1 (enable stop condition detection interrupt request) when the STOP bit is set to 0.

16.3.3 I²C bus Interface Mode

16.3.3.1 I²C bus Format

Setting the FS bit in the SAR register to 0 enables communication in I²C bus format.

Figure 16.32 shows the I²C bus Format and Bus Timing. The 1st frame following the start condition consists of 8 bits.

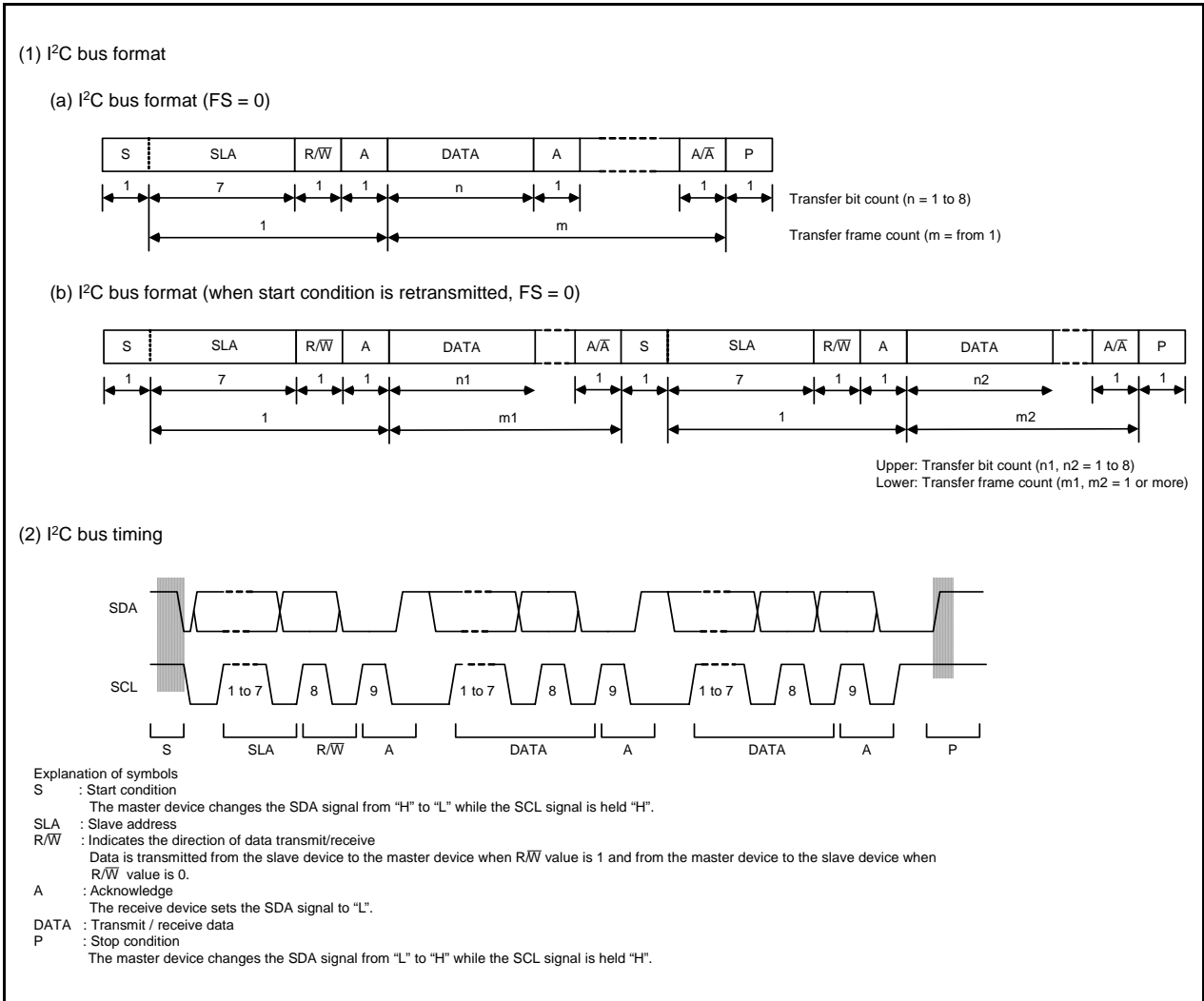

Figure 16.32 I²C bus Format and Bus Timing

16.3.3.2 Master Transmit Operation

In master transmit mode, the master device outputs the transmit clock and data, and the slave device returns an acknowledge signal.

Figures 16.33 and 16.34 show the Operating Timing in Master Transmit Mode (I²C bus Interface Mode).

The transmit procedure and operation in master transmit mode are as follows.

- (1) Set the STOP bit in the ICSR register to 0 to reset it. Then set the ICE bit in the ICCR1 register to 1 (transfer operation enabled). Then set bits WAIT and MLS in the ICMR register and set bits CKS0 to CKS3 in the ICCR1 register (initial setting).
- (2) Read the BBSY bit in the ICCR2 register to confirm that the bus is free. Set bits TRS and MST in the ICCR1 register to master transmit mode. The start condition is generated by writing 1 to the BBSY bit and 0 to the SCP bit by the MOV instruction.
- (3) After confirming that the TDRE bit in the ICSR register is set to 1 (data is transferred from registers ICDRT to ICDRS), write transmit data to the ICDRT register (data in which a slave address and R/W are indicated in the 1st byte). At this time, the TDRE bit is automatically set to 0, data is transferred from registers ICDRT to ICDRS, and the TDRE bit is set to 1 again.
- (4) When transmission of 1 byte of data is completed while the TDRE bit is set to 1, the TEND bit in the ICSR register is set to 1 at the rise of the 9th transmit clock pulse. Read the ACKBR bit in the ICIER register, and confirm that the slave is selected. Write the 2nd byte of data to the ICDRT register. Since the slave device is not acknowledged when the ACKBR bit is set to 1, generate the stop condition. The stop condition is generated by the writing 0 to the BBSY bit and 0 to the SCP bit by the MOV instruction. The SCL signal is held “L” until data is available and the stop condition is generated.
- (5) Write the transmit data after the 2nd byte to the ICDRT register every time the TDRE bit is set to 1.
- (6) When writing the number of bytes to be transmitted to the ICDRT register, wait until the TEND bit is set to 1 while the TDRE bit is set to 1. Or wait for NACK (the NACKF bit in the ICSR register is set to 1) from the receive device while the ACKE bit in the ICIER register is set to 1 (when the receive acknowledge bit is set to 1, transfer is halted). Then generate the stop condition before setting bits TEND and NACKF to 0.
- (7) When the STOP bit in the ICSR register is set to 1, return to slave receive mode.

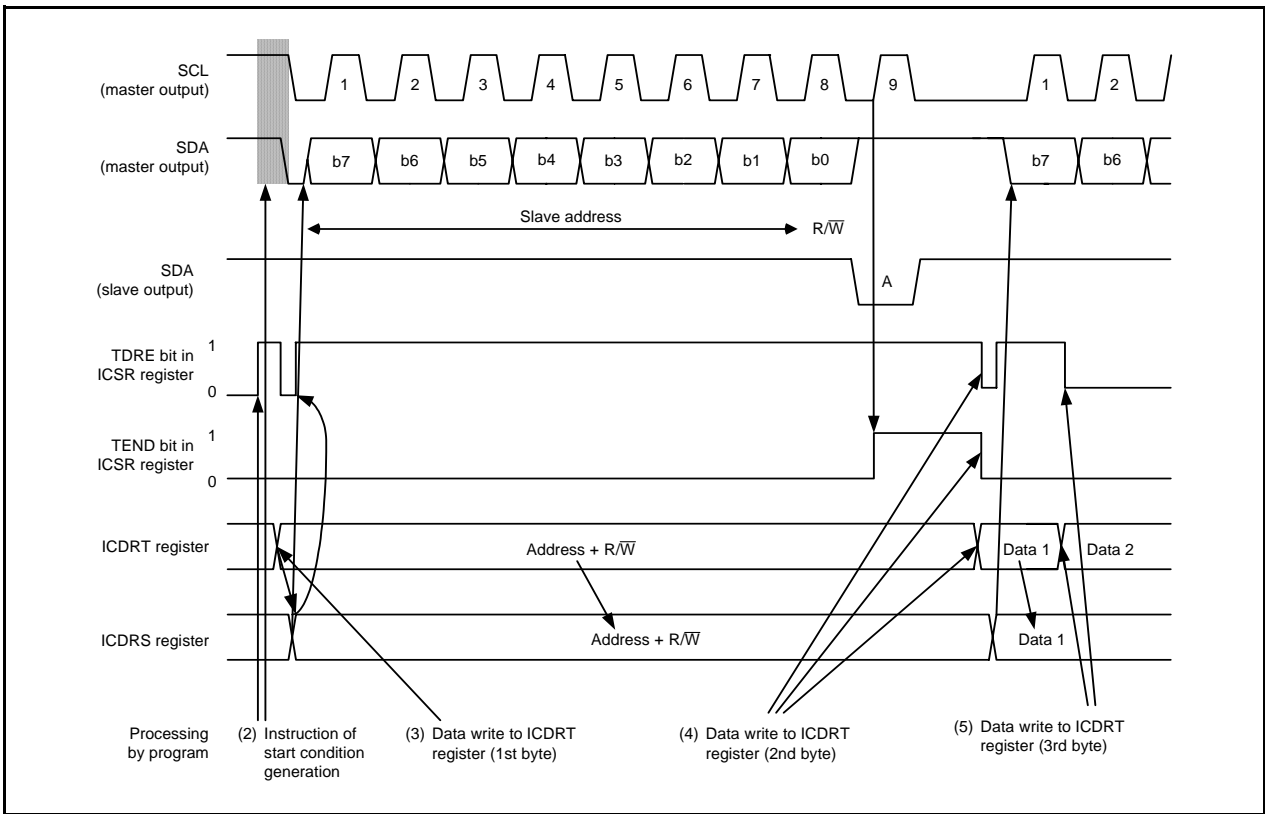

Figure 16.33 Operating Timing in Master Transmit Mode (I²C bus Interface Mode) (1)

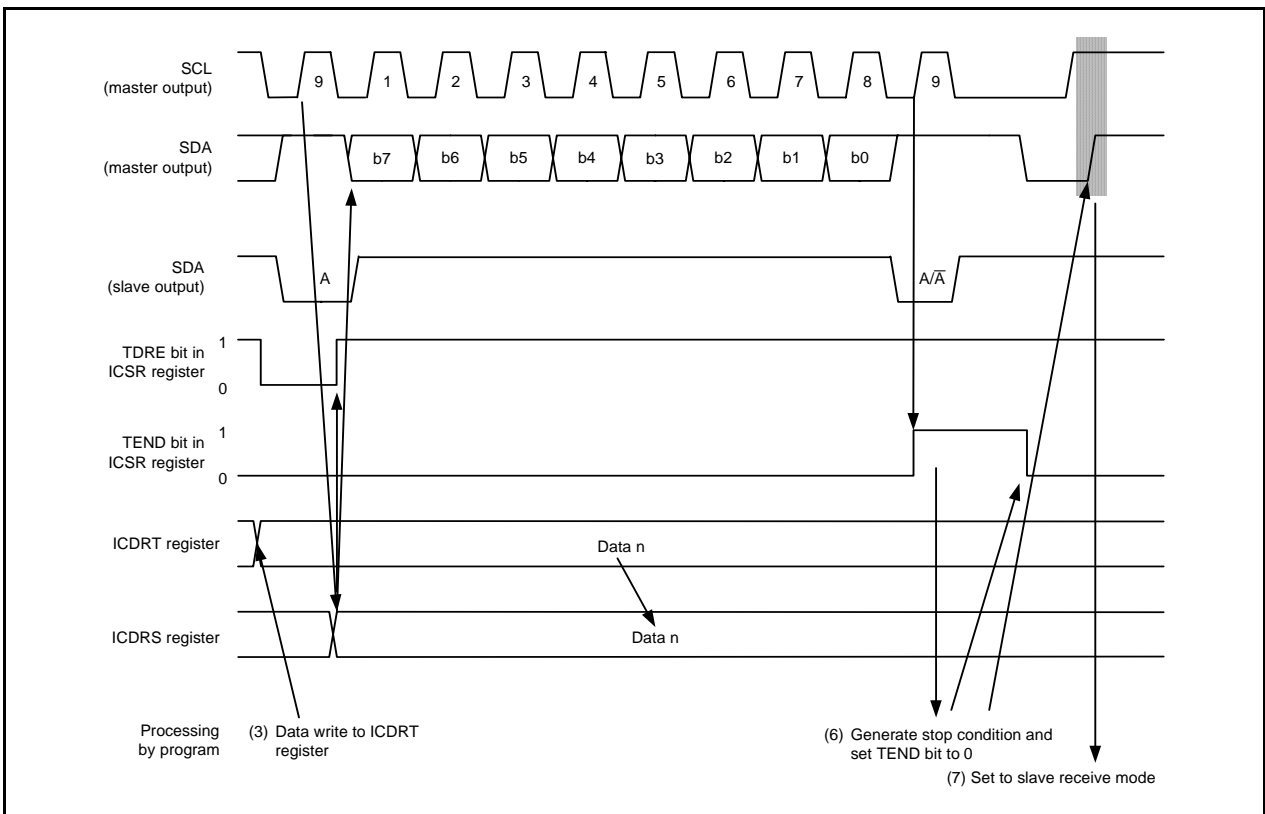

Figure 16.34 Operating Timing in Master Transmit Mode (I²C bus Interface Mode) (2)

16.3.3.3 Master Receive Operation

In master receive mode, the master device outputs the receive clock, receives data from the slave device, and returns an acknowledge signal.

Figures 16.35 and 16.36 show the Operating Timing in Master Receive Mode (I²C bus Interface Mode).

The receive procedure and operation in master receive mode are shown below.

- (1) After setting the TEND bit in the ICSR register to 0, switch from master transmit mode to master receive mode by setting the TRS bit in the ICCR1 register to 0. Also, set the TDRE bit in the ICSR register to 0.
- (2) When performing the dummy read of the ICDRR register and starting the receive operation, the receive clock is output in synchronization with the internal clock and data is received. The master device outputs the level set by the ACKBT bit in the ICIER register to the SDA pin at the rising edge of the 9th clock cycle of the receive clock.
- (3) The 1-frame data receive is completed and the RDRF bit in the ICSR register is set to 1 at the rise of the 9th clock cycle. At this time, when reading the ICDRR register, the received data can be read and the RDRF bit is set to 0 simultaneously.
- (4) Continuous receive operation is enabled by reading the ICDRR register every time the RDRF bit is set to 1. If the 8th clock cycle falls after the ICDRR register is read by another process while the RDRF bit is set to 1, the SCL signal is fixed "L" until the ICDRR register is read.
- (5) If the next frame is the last receive frame and the RCVD bit in the ICCR1 register is set to 1 (disables the next receive operation) before reading the ICDRR register, stop condition generation is enabled after the next receive operation.
- (6) When the RDRF bit is set to 1 at the rise of the 9th clock cycle of the receive clock, generate the stop condition.
- (7) When the STOP bit in the ICSR register is set to 1, read the ICDRR register and set the RCVD bit to 0 (maintain the following receive operation).
- (8) Return to slave receive mode.

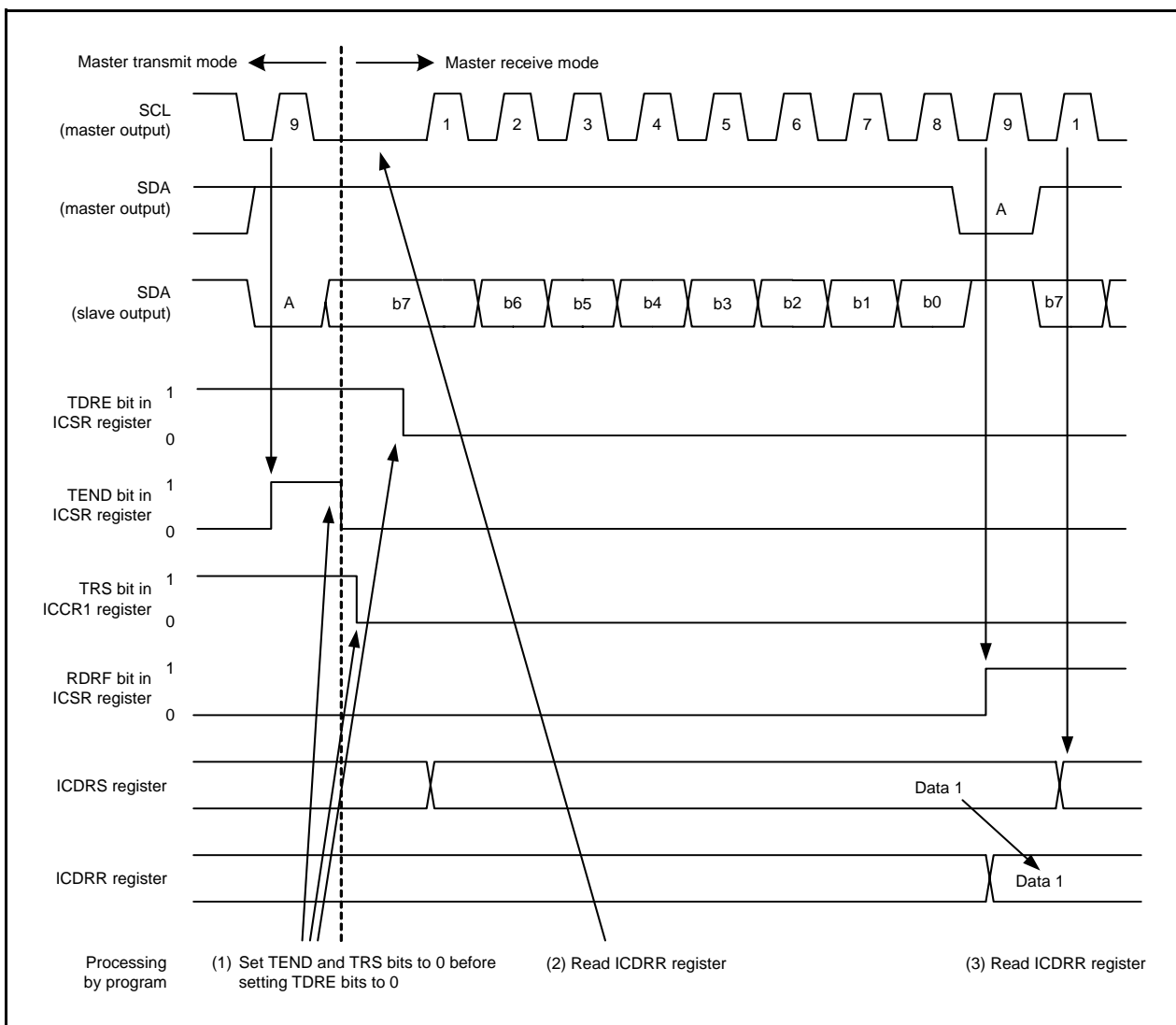

Figure 16.35 Operating Timing in Master Receive Mode (I²C bus Interface Mode) (1)

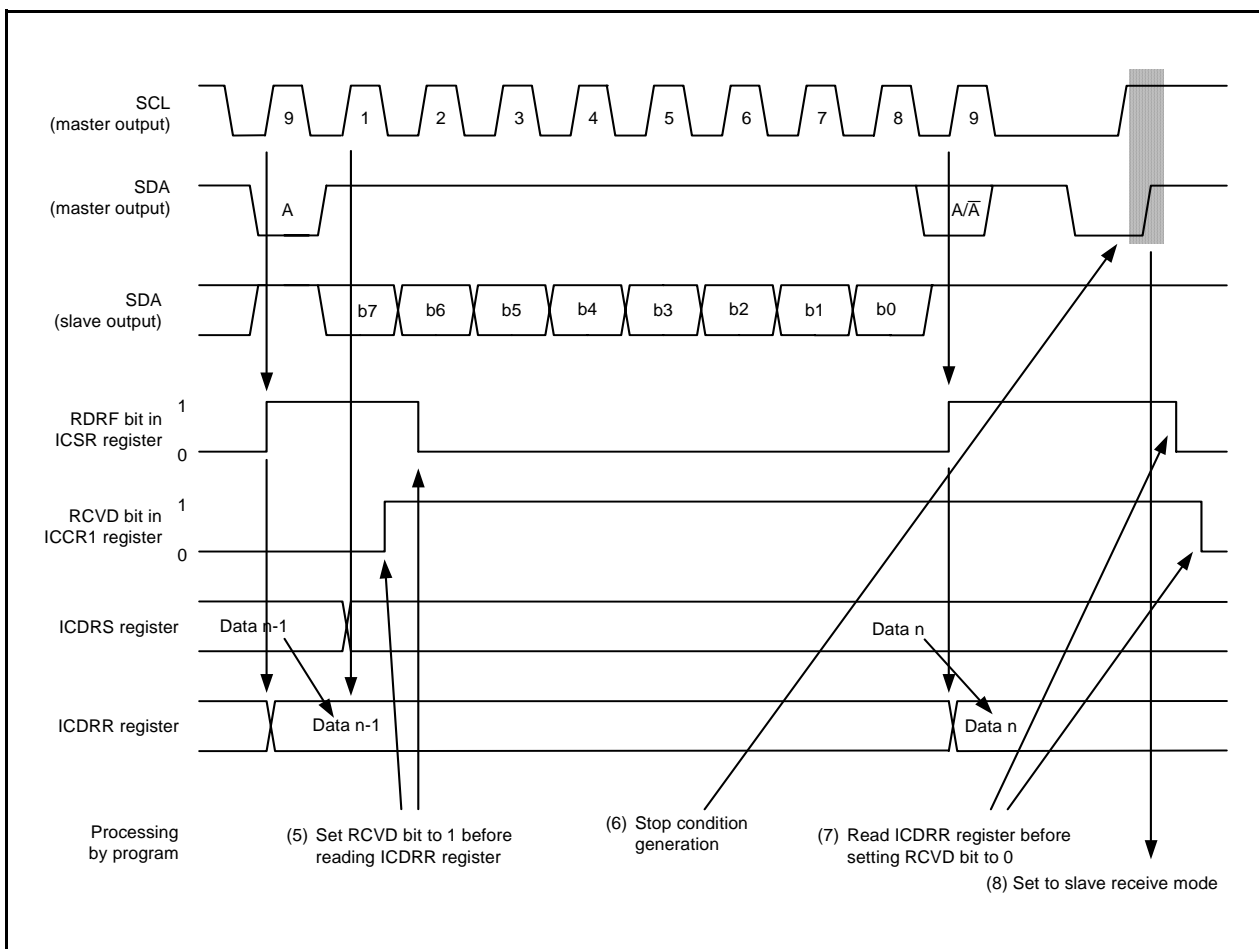

Figure 16.36 Operating Timing in Master Receive Mode (I²C bus Interface Mode) (2)

16.3.3.4 Slave Transmit Operation

In slave transmit mode, the slave device outputs the transmit data while the master device outputs the receive clock and returns an acknowledge signal.

Figures 16.37 and 16.38 show the Operating Timing in Slave Transmit Mode (I²C bus Interface Mode).

The transmit procedure and operation in slave transmit mode are as follows.

- (1) Set the ICE bit in the ICCR1 register to 1 (transfer operation enabled). Set bits WAIT and MLS in the ICMR register and bits CKS0 to CKS3 in the ICCR1 register (initial setting). Set bits TRS and MST in the ICCR1 register to 0 and wait until the slave address matches in slave receive mode.
- (2) When the slave address matches at the 1st frame after detecting the start condition, the slave device outputs the level set by the ACKBT bit in the ICIER register to the SDA pin at the rise of the 9th clock cycle. At this time, if the 8th bit of data (R/\overline{W}) is 1, bits TRS and TDRE in the ICSR register are set to 1, and the mode is switched to slave transmit mode automatically. Continuous transmission is enabled by writing transmit data to the ICDRT register every time the TDRE bit is set to 1.
- (3) When the TDRE bit in the ICDRT register is set to 1 after writing the last transmit data to the ICDRT register, wait until the TEND bit in the ICSR register is set to 1 while the TDRE bit is set to 1. When the TEND bit is set to 1, set the TEND bit to 0.
- (4) The SCL signal is released by setting the TRS bit to 0 and performing a dummy read of the ICDRR register to end the process.
- (5) Set the TDRE bit to 0.

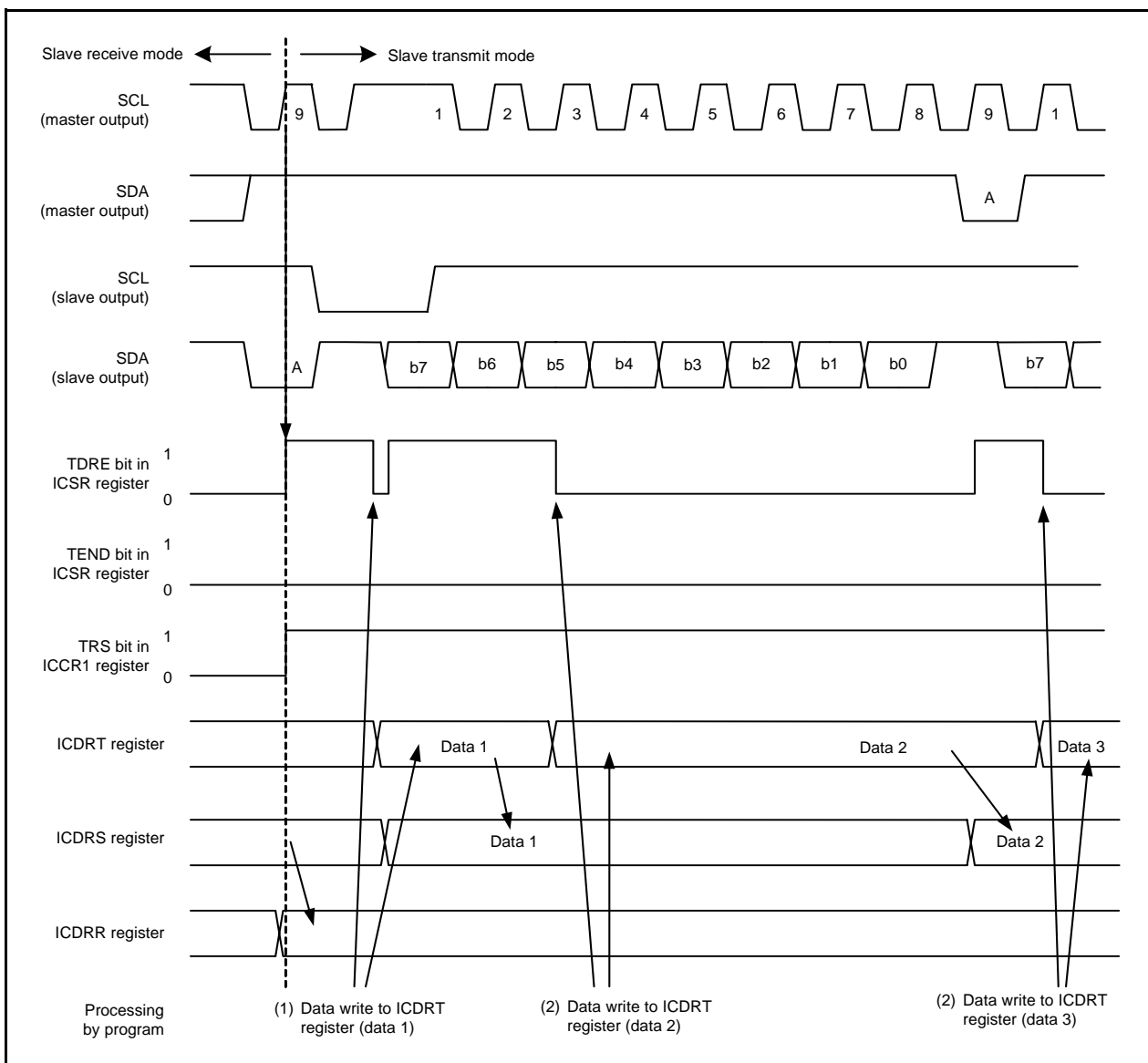

Figure 16.37 Operating Timing in Slave Transmit Mode (I2C bus Interface Mode) (1)

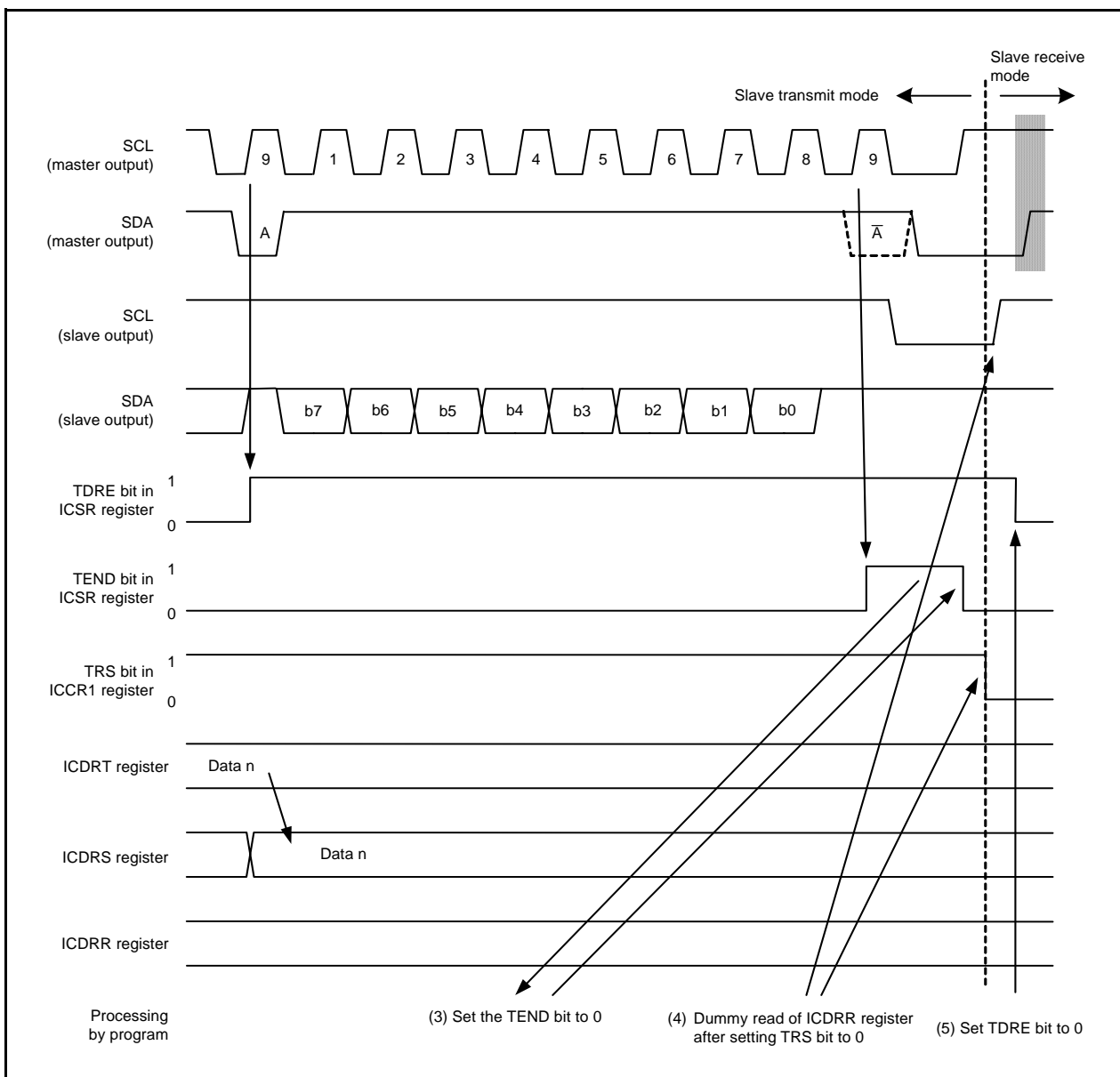

Figure 16.38 Operating Timing in Slave Transmit Mode (I2C bus interface Mode) (2)

16.3.3.5 Slave Receive Operation

In slave receive mode, the master device outputs the transmit clock and data, and the slave device returns an acknowledge signal.

Figures 16.39 and 16.40 show the Operating Timing in Slave Receive Mode (I²C bus Interface Mode).

The receive procedure and operation in slave receive mode are as follows.

- (1) Set the ICE bit in the ICCR1 register to 1 (transfer operation enabled). Set bits WAIT and MLS in the ICMR register and bits CKS0 to CKS3 in the ICCR1 register (initial setting). Set bits TRS and MST in the ICCR1 register to 0 and wait until the slave address matches in slave receive mode.
- (2) When the slave address matches at the 1st frame after detecting the start condition, the slave device outputs the level set in the ACKBT bit in the ICIER register to the SDA pin at the rise of the 9th clock cycle. Since the RDRF bit in the ICSR register is set to 1 simultaneously, perform the dummy read (the read data is unnecessary because it indicates the slave address and R/W).
- (3) Read the ICDRR register every time the RDRF bit is set to 1. If the 8th clock cycle falls while the RDRF bit is set to 1, the SCL signal is fixed "L" until the ICDRR register is read. The setting change of the acknowledge signal returned to the master device before reading the ICDRR register takes affect from the following transfer frame.
- (4) Reading the last byte is performed by reading the ICDRR register in like manner.

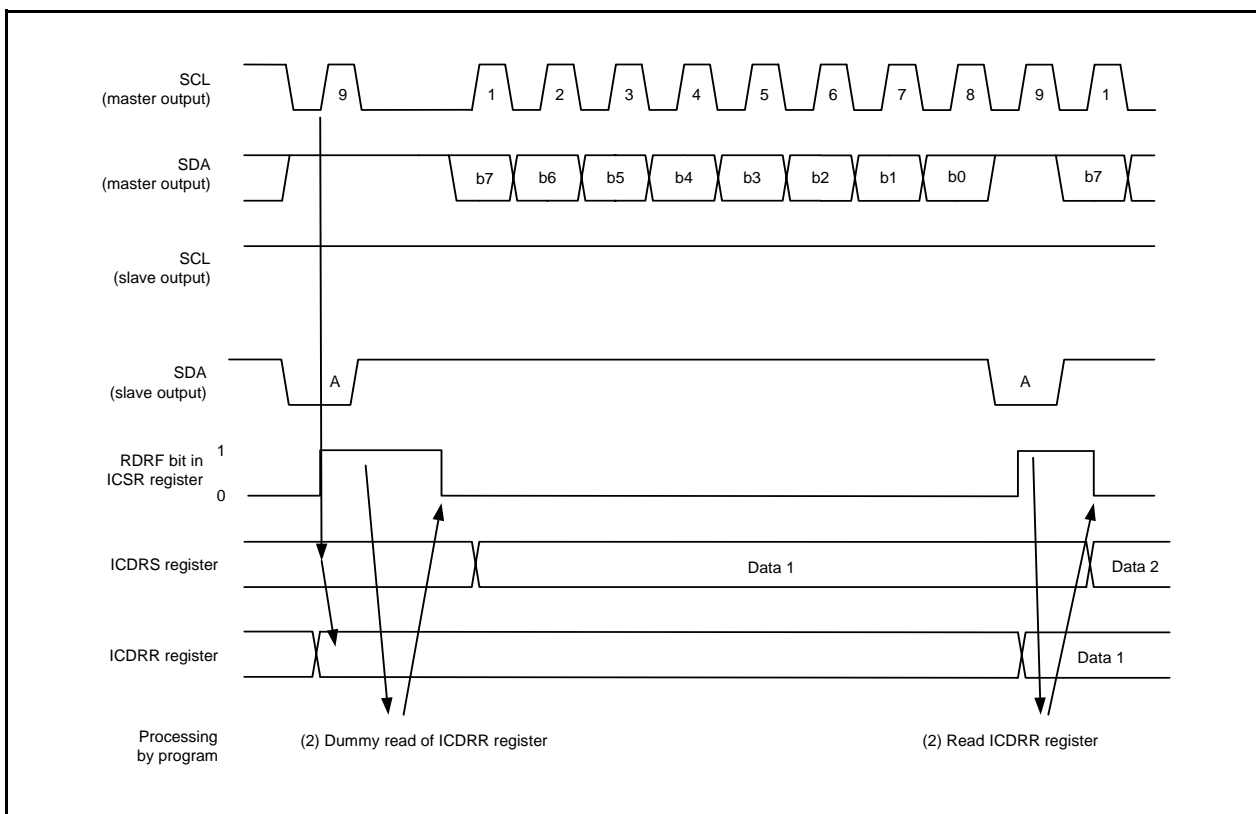

Figure 16.39 Operating Timing in Slave Receive Mode (I²C bus Interface Mode) (1)

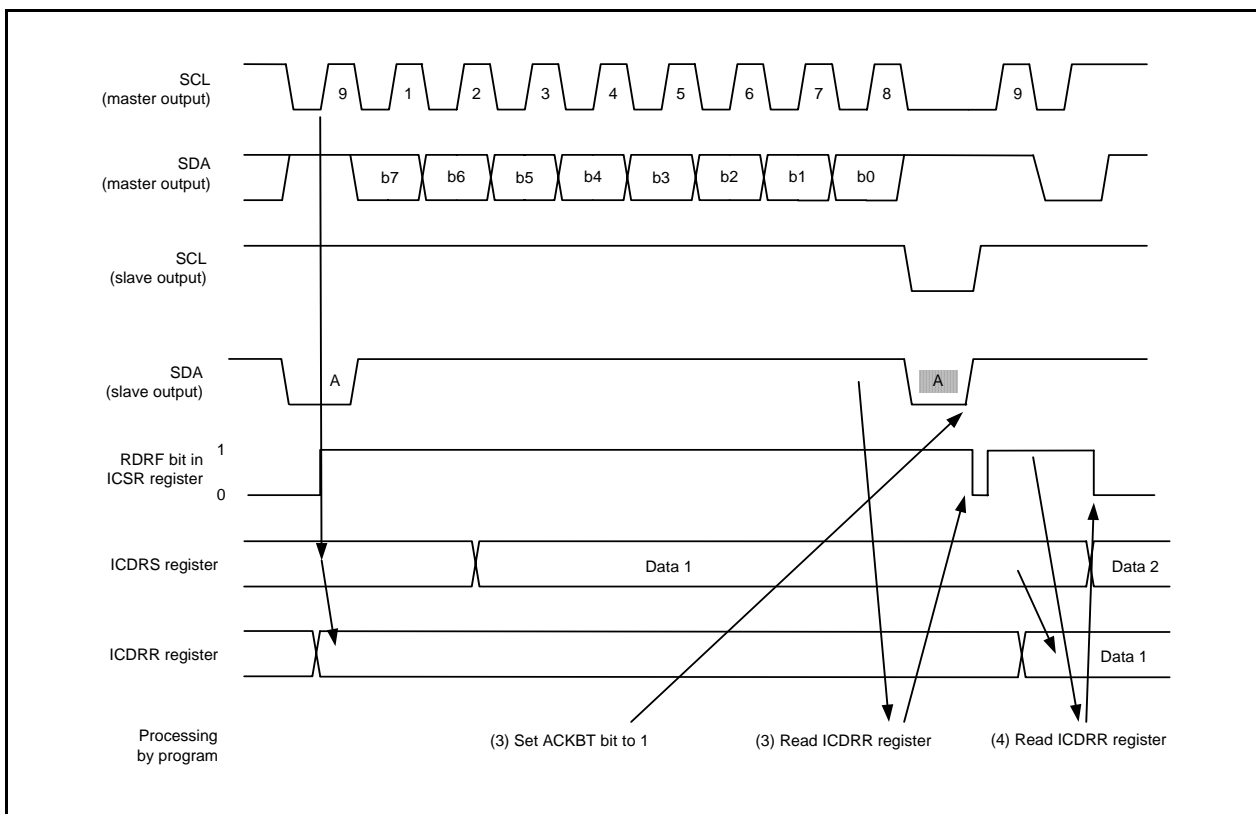

Figure 16.40 Operating Timing in Slave Receive Mode (I²C bus Interface Mode) (2)

16.3.4 Clock Synchronous Serial Mode

16.3.4.1 Clock Synchronous Serial Format

Set the FS bit in the SAR register to 1 to use the clock synchronous serial format for communication. Figure 16.41 shows the Transfer Format of Clock Synchronous Serial Format.

When the MST bit in the ICCR1 register is set to 1, the transfer clock is output from the SCL pin, and when the MST bit is set to 0, the external clock is input.

The transfer data is output between successive falling edges of the SCL clock, and data is determined at the rising edge of the SCL clock. MSB-first or LSB-first can be selected as the order of the data transfer by setting the MLS bit in the ICMR register. The SDA output level can be changed by the SDAO bit in the ICCR2 register during transfer standby.

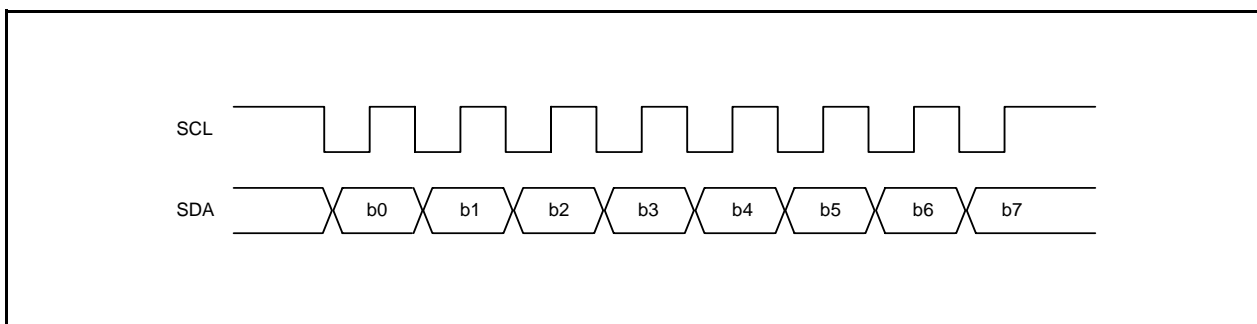

Figure 16.41 Transfer Format of Clock Synchronous Serial Format

16.3.4.2 Transmit Operation

In transmit mode, transmit data is output from the SDA pin in synchronization with the falling edge of the transfer clock. The transfer clock is output when the MST bit in the ICCR1 register is set to 1 and input when the MST bit is set to 0.

Figure 16.42 shows the Operating Timing in Transmit Mode (Clock Synchronous Serial Mode).

The transmit procedure and operation in transmit mode are as follows.

- (1) Set the ICE bit in the ICCR1 register to 1 (transfer operation enabled). Set bits CKS0 to CKS3 in the ICCR1 register and set the MST bit (initial setting).
- (2) The TDRE bit in the ICSR register is set to 1 by selecting transmit mode after setting the TRS bit in the ICCR1 register to 1.
- (3) Data is transferred from registers ICDRT to ICDRS and the TDRE bit is automatically set to 1 by writing transmit data to the ICDRT register after confirming that the TDRE bit is set to 1. Continuous transmission is enabled by writing data to the ICDRT register every time the TDRE bit is set to 1. When switching from transmit to receive mode, set the TRS bit to 0 while the TDRE bit is set to 1.

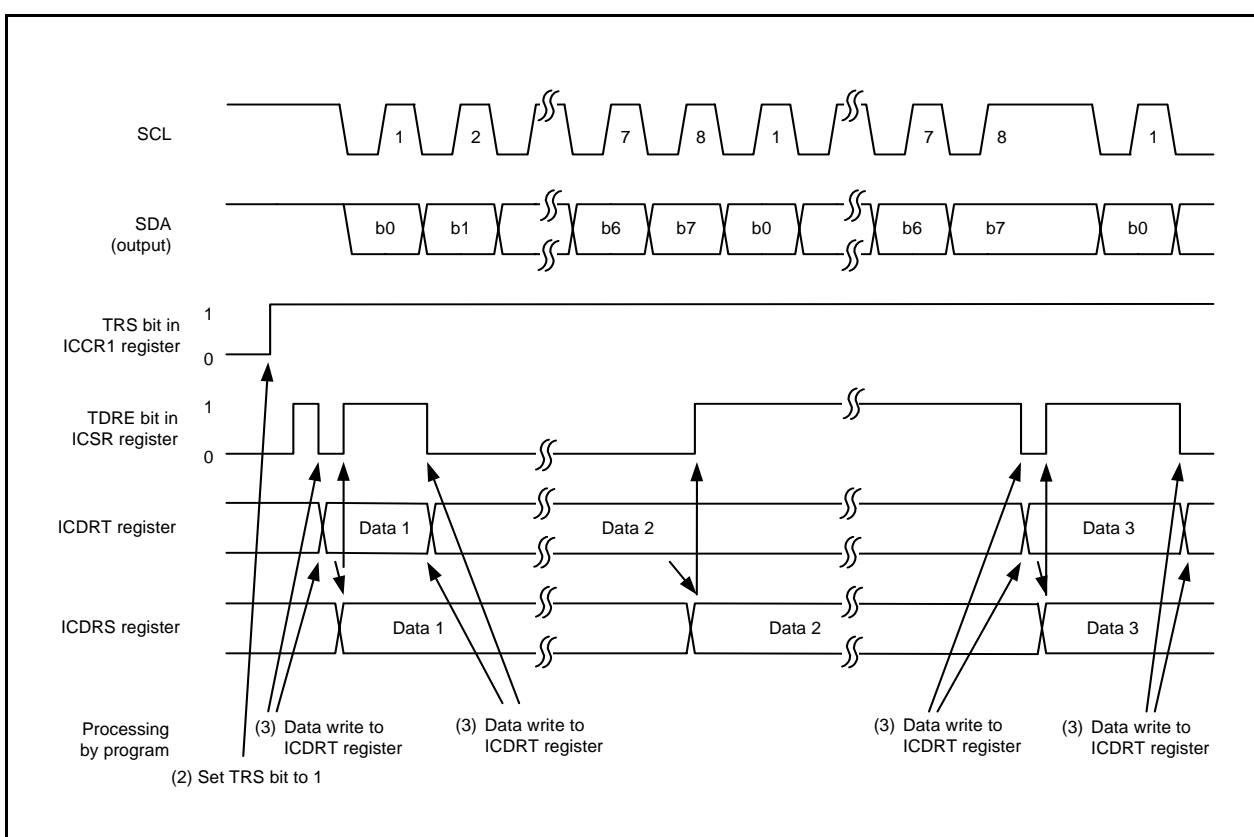

Figure 16.42 Operating Timing in Transmit Mode (Clock Synchronous Serial Mode)

16.3.4.3 Receive Operation

In receive mode, data is latched at the rising edge of the transfer clock. The transfer clock is output when the MST bit in the ICCR1 register is set to 1 and input when the MST bit is set to 0.

Figure 16.43 shows the Operating Timing in Receive Mode (Clock Synchronous Serial Mode).

The receive procedure and operation in receive mode are as follows.

- (1) Set the ICE bit in the ICCR1 register to 1 (transfer operation enabled). Set bits CKS0 to CKS3 in the ICCR1 register and set the MST bit (initial setting).
- (2) The output of the receive clock starts when the MST bit is set to 1 while the transfer clock is being output.
- (3) Data is transferred from registers ICDRS to ICDRR and the RDRF bit in the ICSR register is set to 1, when the receive operation is completed. Since the next byte of data is enabled when the MST bit is set to 1, the clock is output continuously. Continuous reception is enabled by reading the ICDRR register every time the RDRF bit is set to 1. An overrun is detected at the rise of the 8th clock cycle while the RDRF bit is set to 1, and the AL bit in the ICSR register is set to 1. At this time, the last receive data is retained in the ICDRR register.
- (4) When the MST bit is set to 1, set the RCVD bit in the ICCR1 register to 1 (disables the next receive operation) and read the ICDRR register. The SCL signal is fixed “H” after reception of the following byte of data is completed.

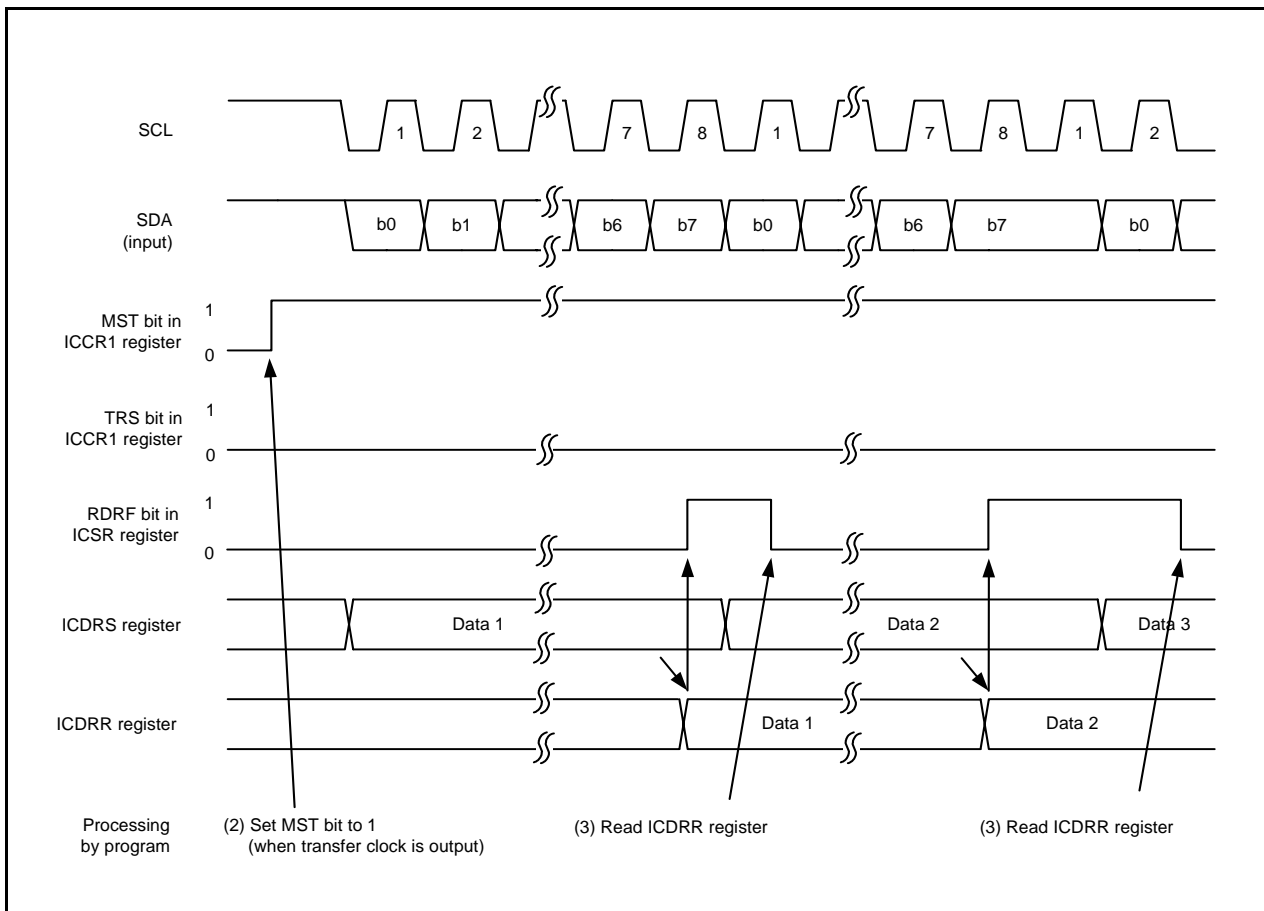

Figure 16.43 Operating Timing in Receive Mode (Clock Synchronous Serial Mode)

16.3.5 Noise Canceller

The states of pins SCL and SDA are routed through the noise canceller before being latched internally. Figure 16.44 shows a Block Diagram of Noise Canceller.

The noise canceller consists of two cascaded latch and match detector circuits. When the SCL pin input signal (or SDA pin input signal) is sampled on f1 and two latch outputs match, the level is passed forward to the next circuit. When they do not match, the former value is retained.

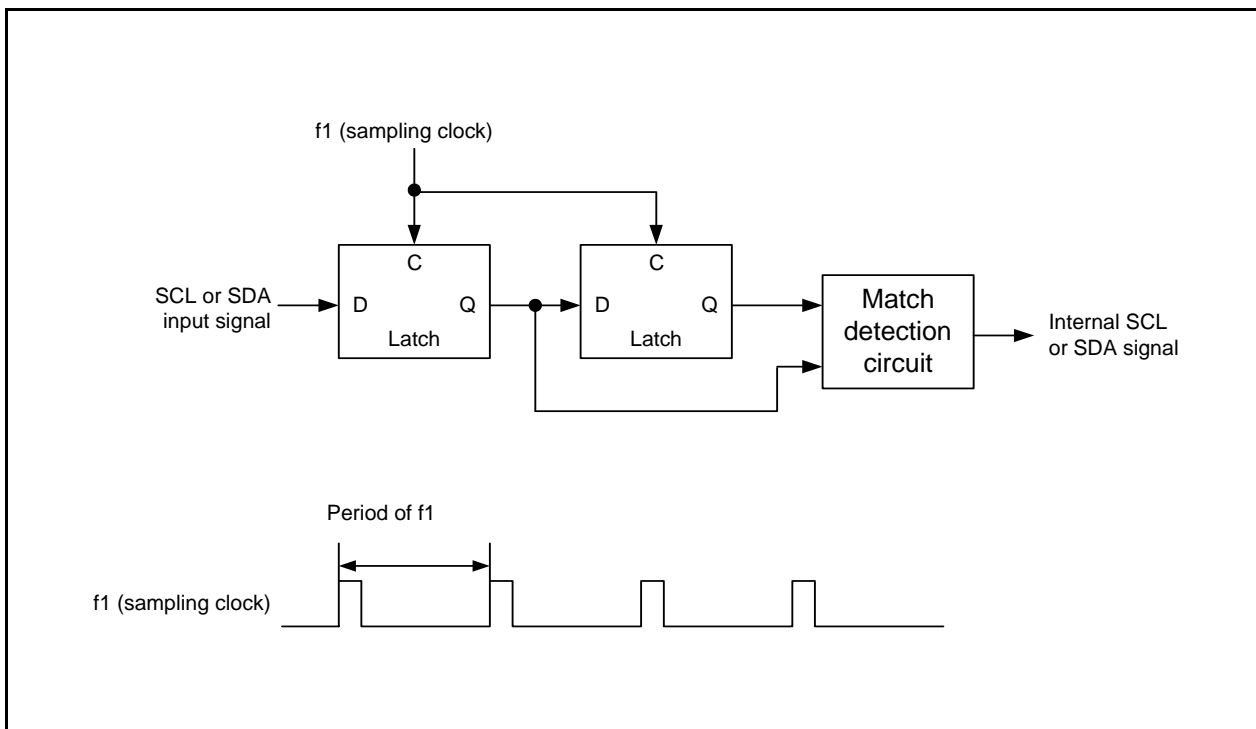

Figure 16.44 Block Diagram of Noise Canceller

16.3.6 Bit Synchronization Circuit

When setting the I²C bus interface to master mode, the high-level period may become shorter in the following two cases:

- If the SCL signal is driven L level by a slave device
- If the rise speed of the SCL signal is reduced by a load (load capacity or pull-up resistor) on the SCL line.

Therefore, the SCL signal is monitored and communication is synchronized bit by bit.

Figure 16.45 shows the Timing of Bit Synchronization Circuit and Table 16.8 lists the Time between Changing SCL Signal from “L” Output to High-Impedance and Monitoring of SCL Signal.

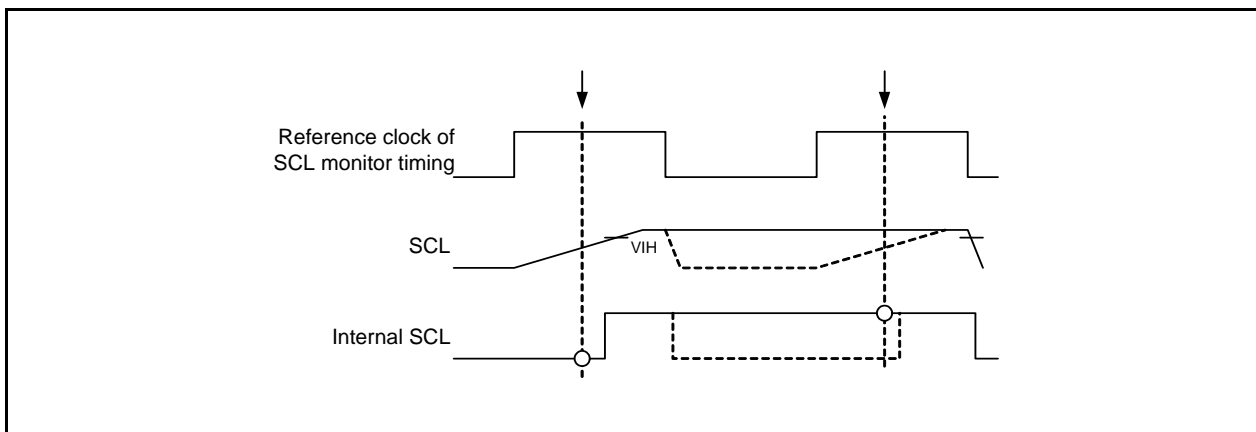

Figure 16.45 Timing of Bit Synchronization Circuit

Table 16.8 Time between Changing SCL Signal from “L” Output to High-Impedance and Monitoring of SCL Signal

ICCR1 Register		Time for Monitoring SCL
CKS3	CKS2	
0	0	7.5Tcyc
	1	19.5Tcyc
1	0	17.5Tcyc
	1	41.5Tcyc

1Tcyc = 1/f1(s)

16.3.7 Examples of Register Setting

Figures 16.46 to 16.49 show Examples of Register Setting When Using I²C bus interface.

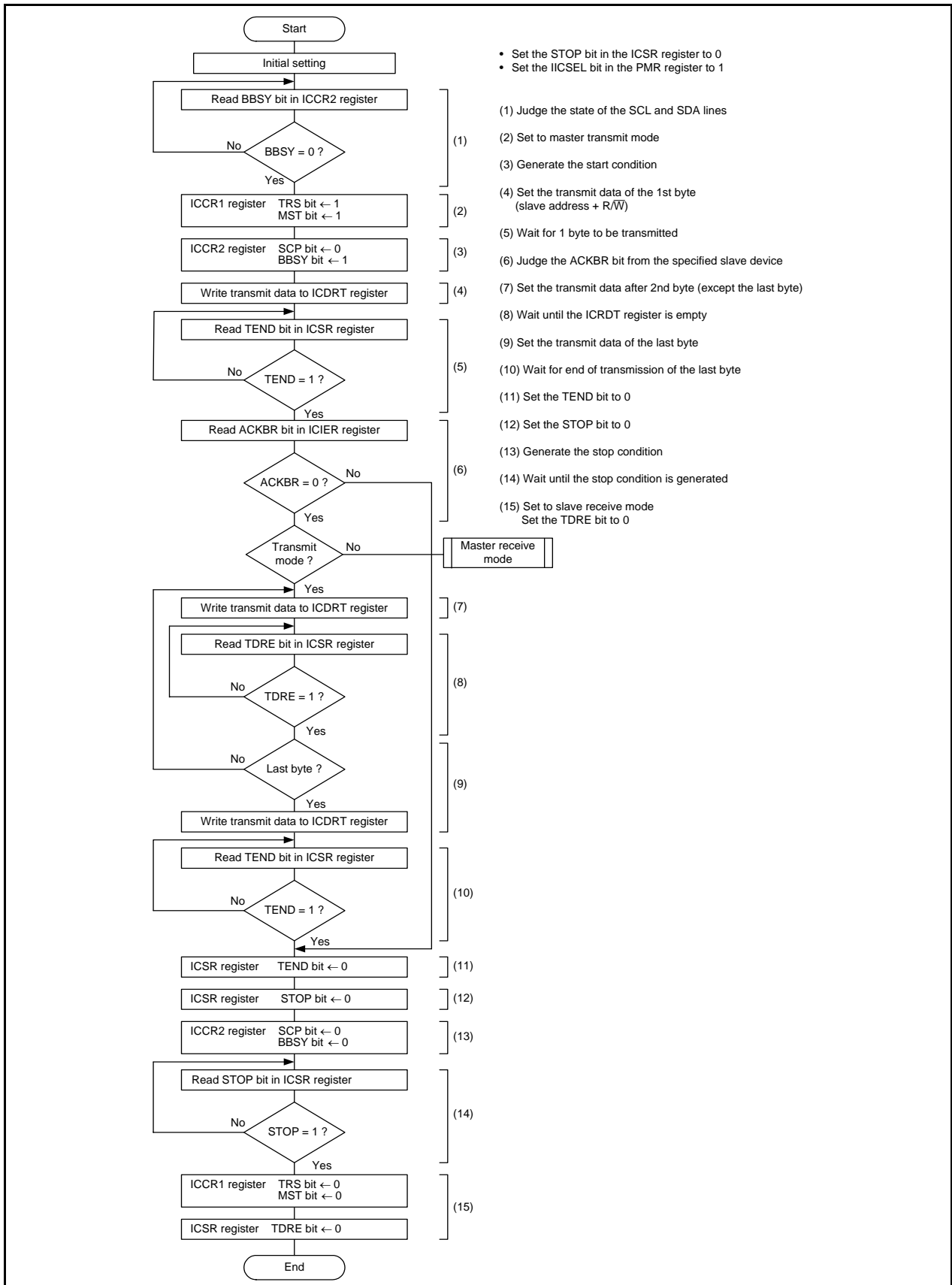

Figure 16.46 Example of Register Setting in Master Transmit Mode (I²C bus Interface Mode)

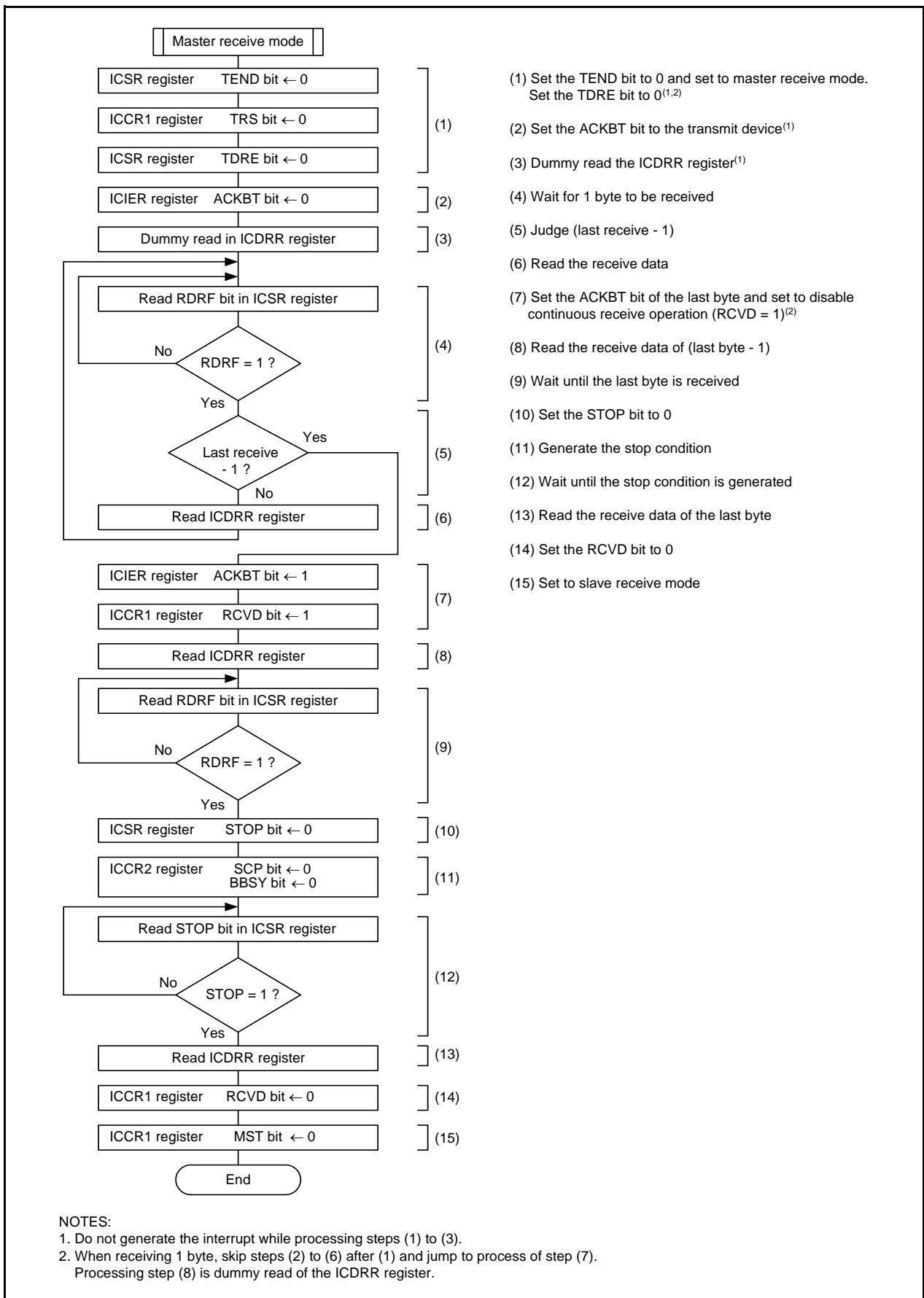

Figure 16.47 Example of Register Setting in Master Receive Mode (I²C bus Interface Mode)

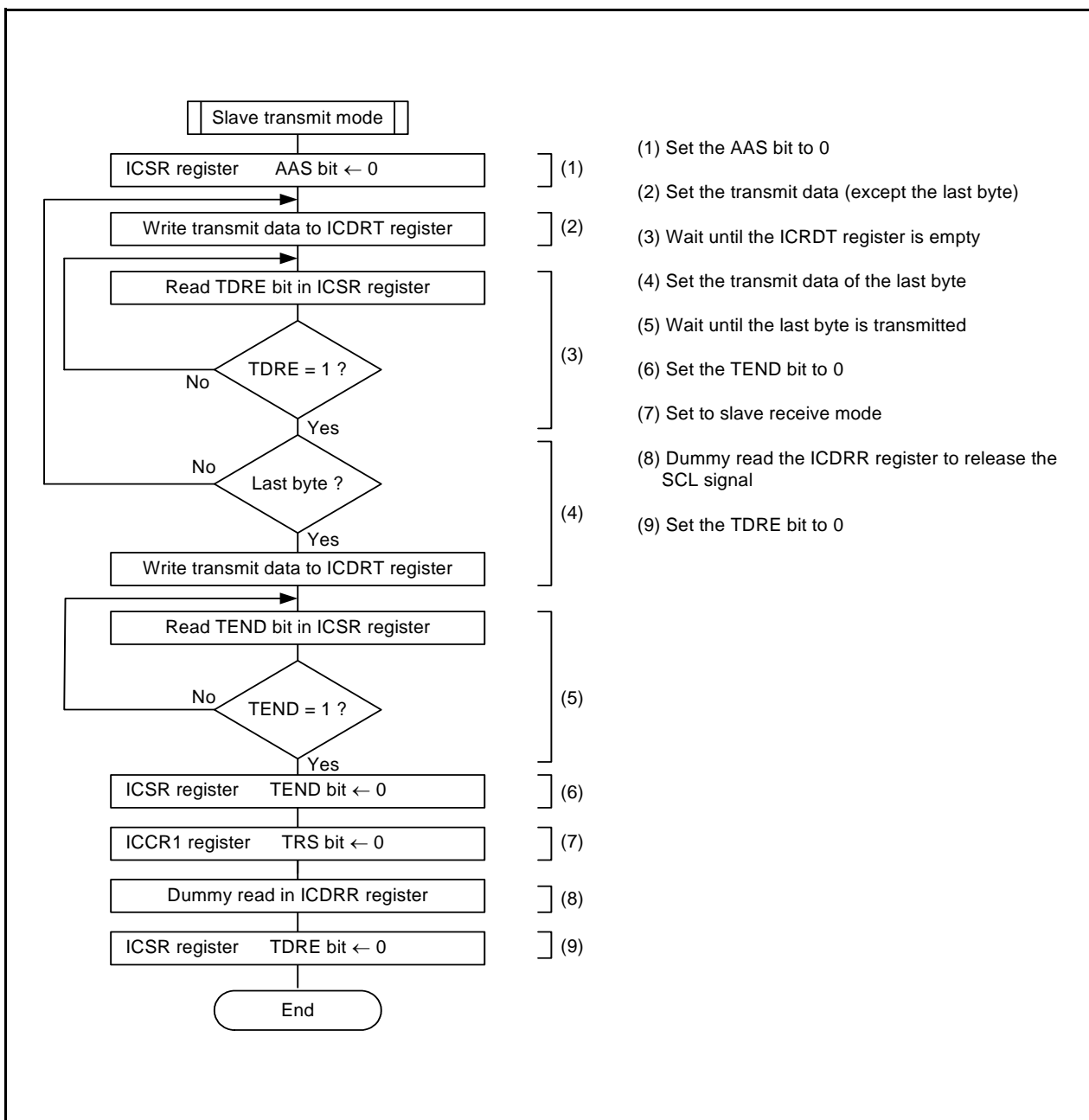

Figure 16.48 Example of Register Setting in Slave Transmit Mode (I²C bus Interface Mode)

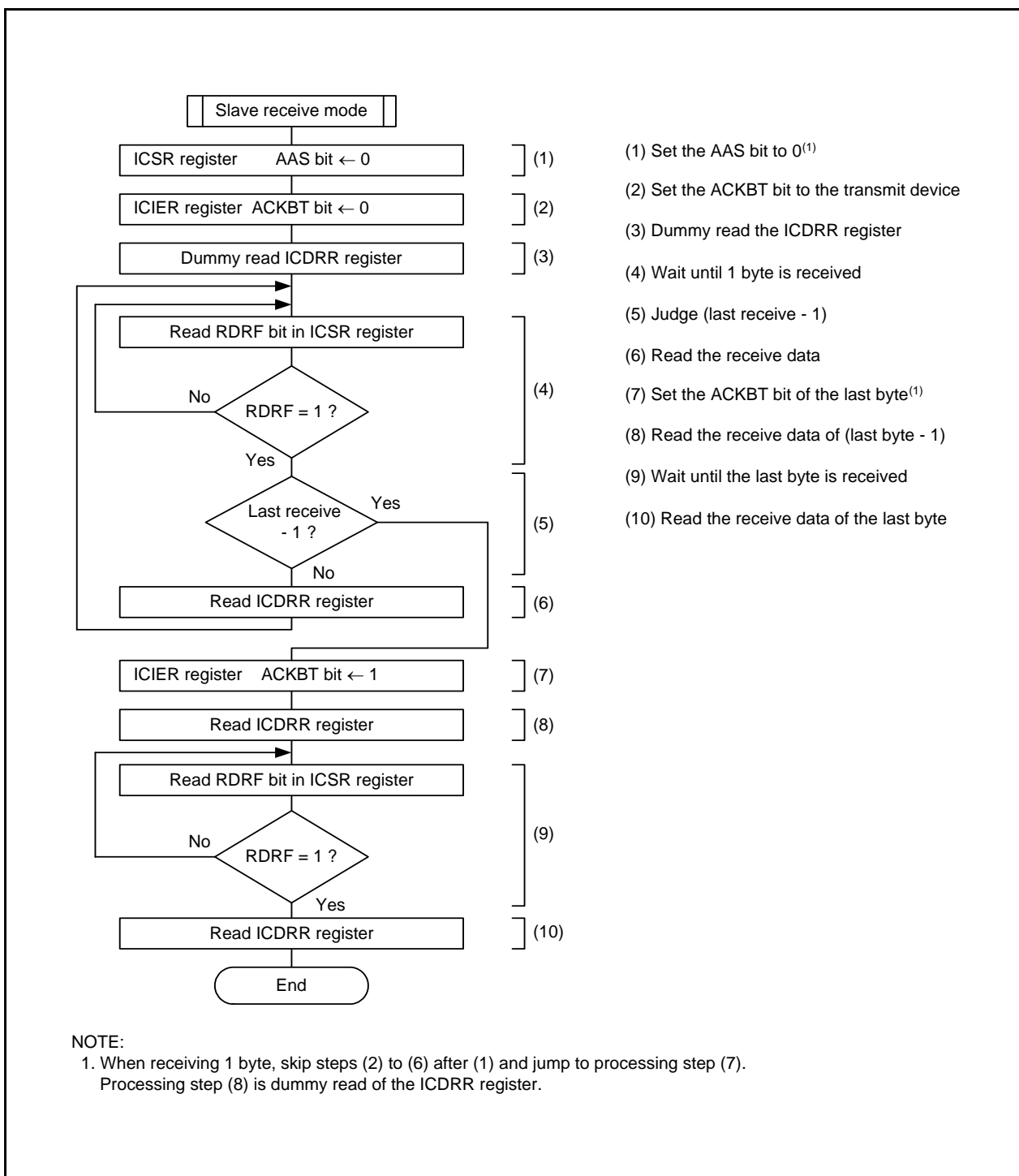

Figure 16.49 Example of Register Setting in Slave Receive Mode (I²C bus Interface Mode)

16.3.8 Notes on I²C bus Interface

Set the IICSEL bit in the PMR register to 1 (select I²C bus interface function) to use the I²C bus interface.

16.3.8.1 Accessing of Registers Associated with I²C bus Interface

Wait for three instructions or more or four cycles or more after writing to the same register among the registers associated with the I²C bus Interface (00B8h to 00BFh) before reading it.

- An example of waiting three instructions or more

```

Program example      MOV.B  #00h,00BBh    ; Set ICIER register to 00h
                    NOP
                    NOP
                    NOP
                    MOV.B  00BBh,R0L
  
```

- An example of waiting four cycles or more

```

Program example      BCLR   6,00BBh    ; Disable transmit end interrupt request
                    JMP.B  NEXT
NEXT:
                    BSET   7,00BBh    ; Enable transmit data empty interrupt request
  
```

17. Hardware LIN

The hardware LIN performs LIN communication in cooperation with timer RA and UART0.

17.1 Features

The hardware LIN has the features listed below.

Figure 17.1 shows a Block Diagram of Hardware LIN.

Master mode

- Generates Synch Break
- Detects bus collision

Slave mode

- Detects Synch Break
- Measures Synch Field
- Controls Synch Break and Synch Field signal inputs to UART0
- Detects bus collision

NOTE:

1. The WakeUp function is detected by INT1.

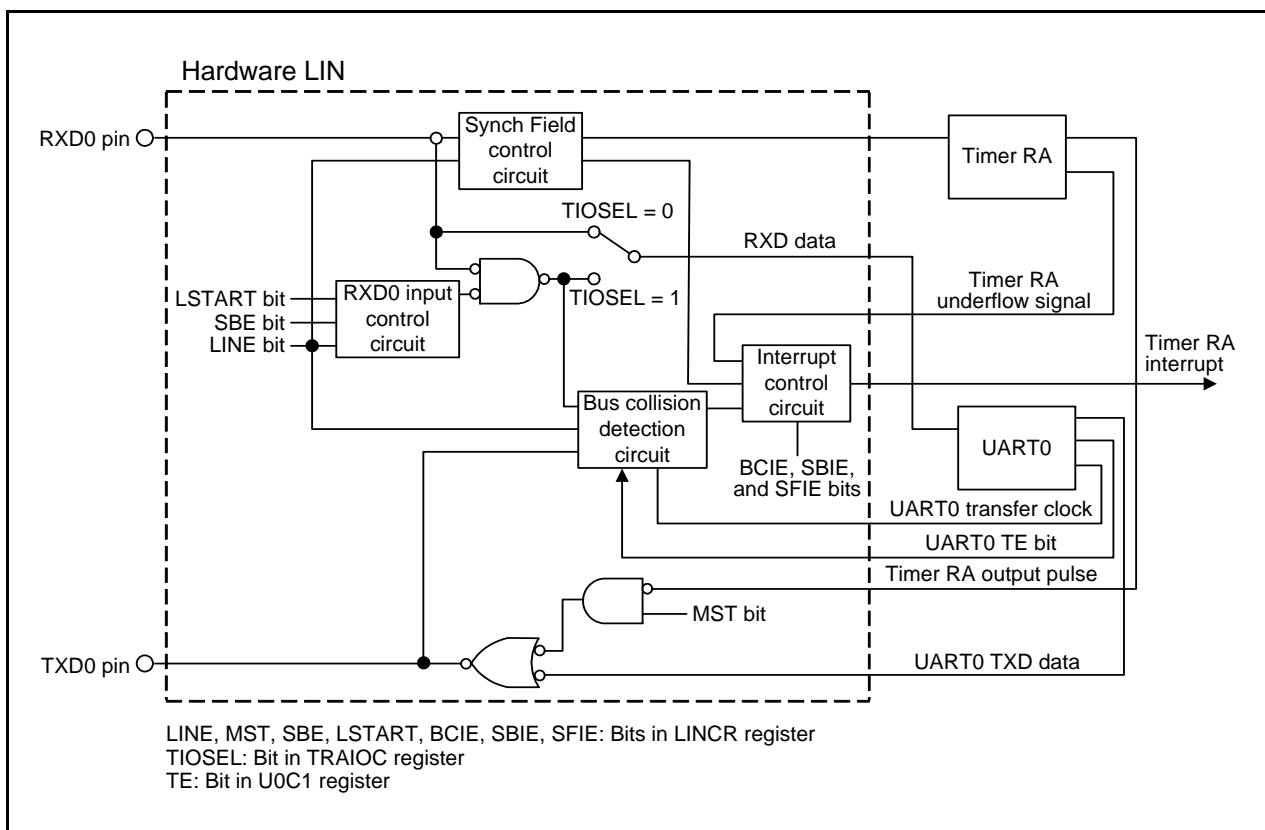

Figure 17.1 Block Diagram of Hardware LIN

17.2 Input/Output Pins

The pin configuration of the hardware LIN is listed in Table 17.1.

Table 17.1 Pin Configuration

Name	Abbreviation	Input/Output	Function
Receive data input	RXD0	Input	Receive data input pin of the hardware LIN
Transmit data output	TXD0	Output	Transmit data output pin of the hardware LIN

17.3 Register Configuration

The hardware LIN contains the registers listed below.
These registers are detailed in Figures 17.2 and 17.3.

- LIN Control Register (LINCR)
- LIN Status Register (LINST)

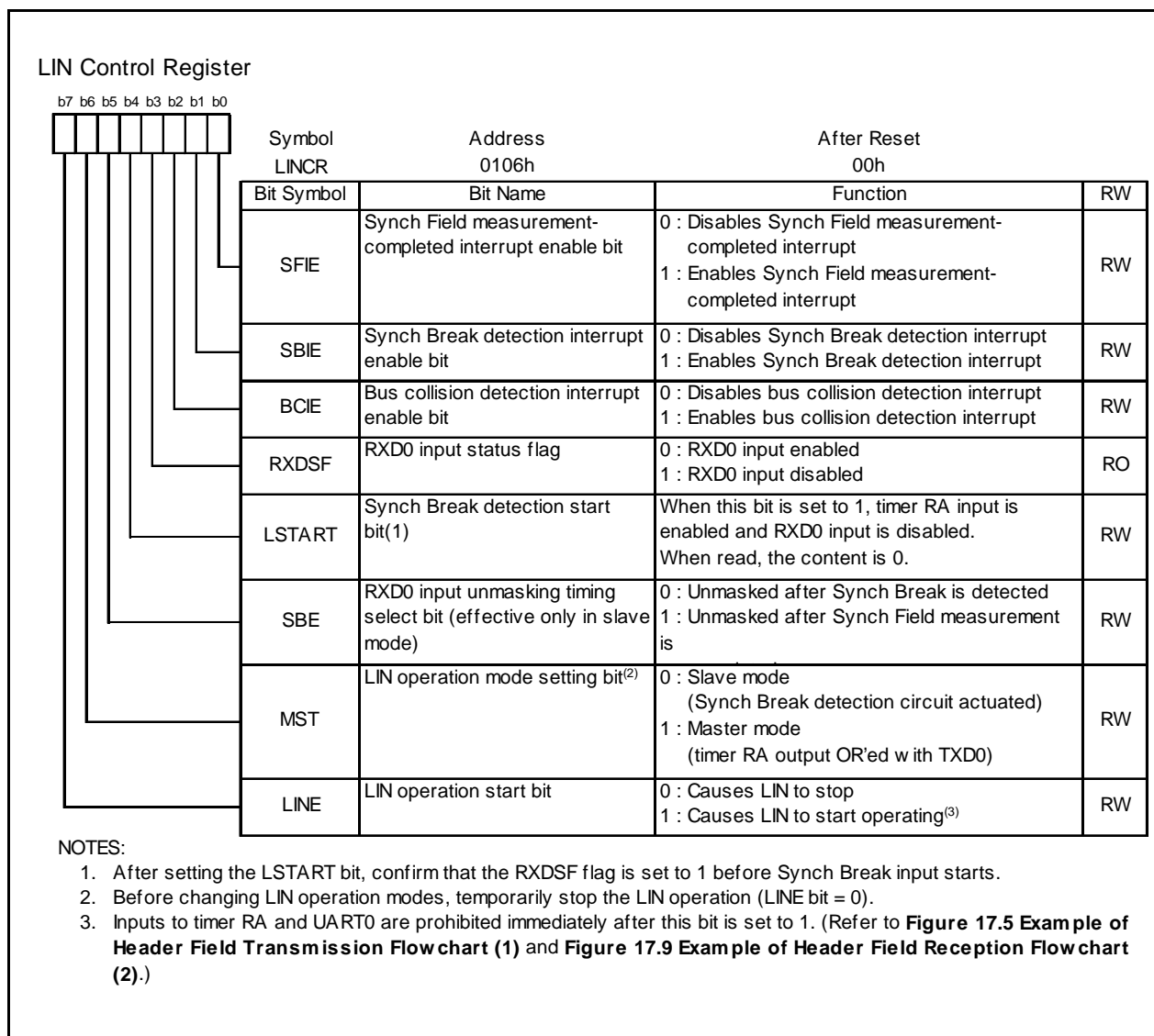

Figure 17.2 LINCR Register

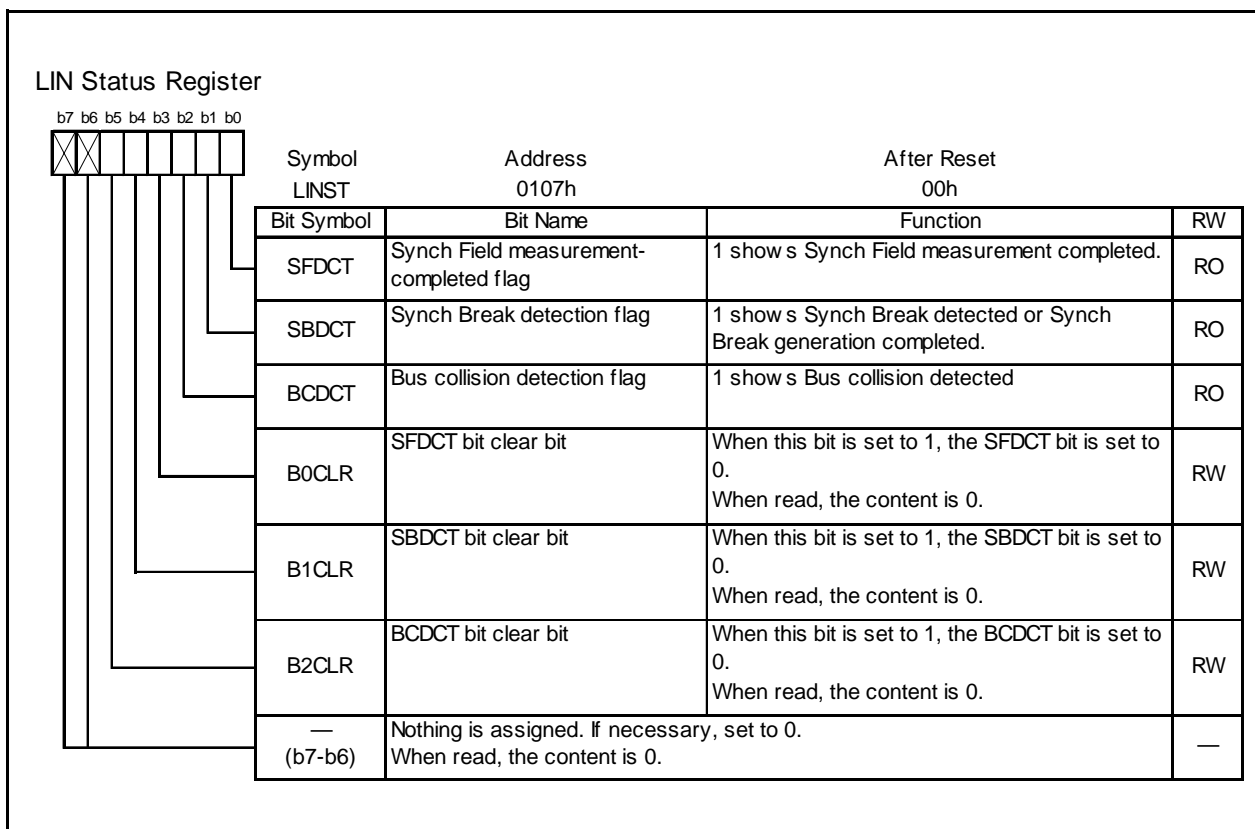

Figure 17.3 LINST Register

17.4 Functional Description

17.4.1 Master Mode

Figure 17.4 shows typical operation of the hardware LIN when transmitting a header field in master mode. Figures 17.5 and 17.6 show a flowchart of the procedure for transmitting a header field.

When transmitting a header field, the hardware LIN operates as described below.

- (1) When the TSTART bit in the TRACR register for timer RA is set by writing 1 in software, the hardware LIN outputs “L” level from the TXD0 pin for the period that is set in registers TRAPRE and TRA for timer RA.
- (2) When timer RA underflows upon reaching the terminal count, the hardware LIN reverses the output of the TXD0 pin and sets the SBDCT flag in the LINST register to 1. Furthermore, if the SBIE bit in the LINC register is set to 1, it generates a timer RA interrupt.
- (3) The hardware LIN transmits 55h via UART0.
- (4) The hardware LIN transmits an ID field via UART0 after it finishes sending 55h.
- (5) The hardware LIN performs communication for a response field after it finishes sending the ID field.

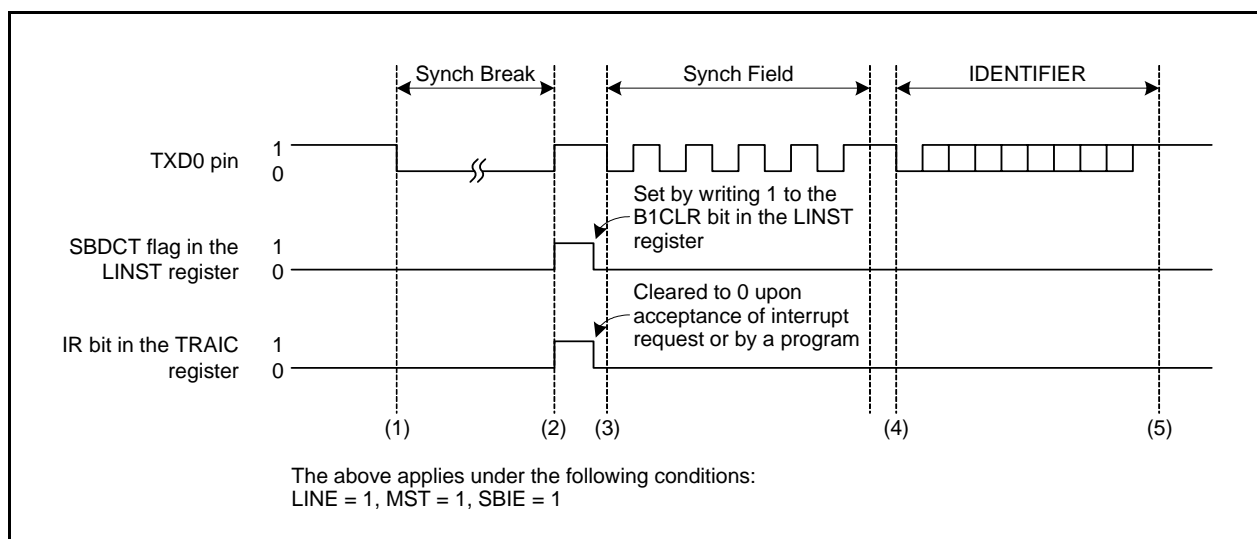

Figure 17.4 Typical Operation when Sending a Header Field

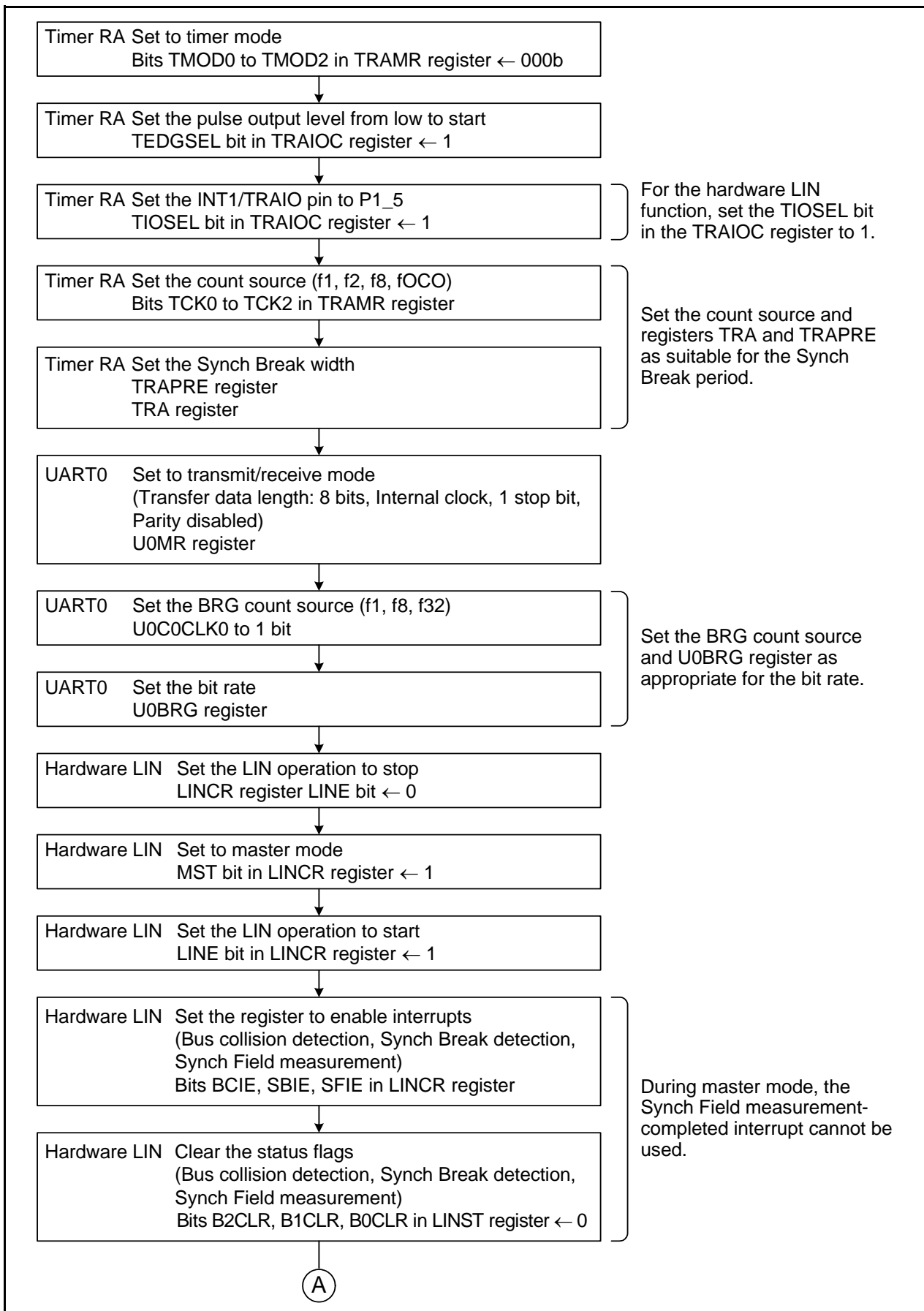

Figure 17.5 Example of Header Field Transmission Flowchart (1)

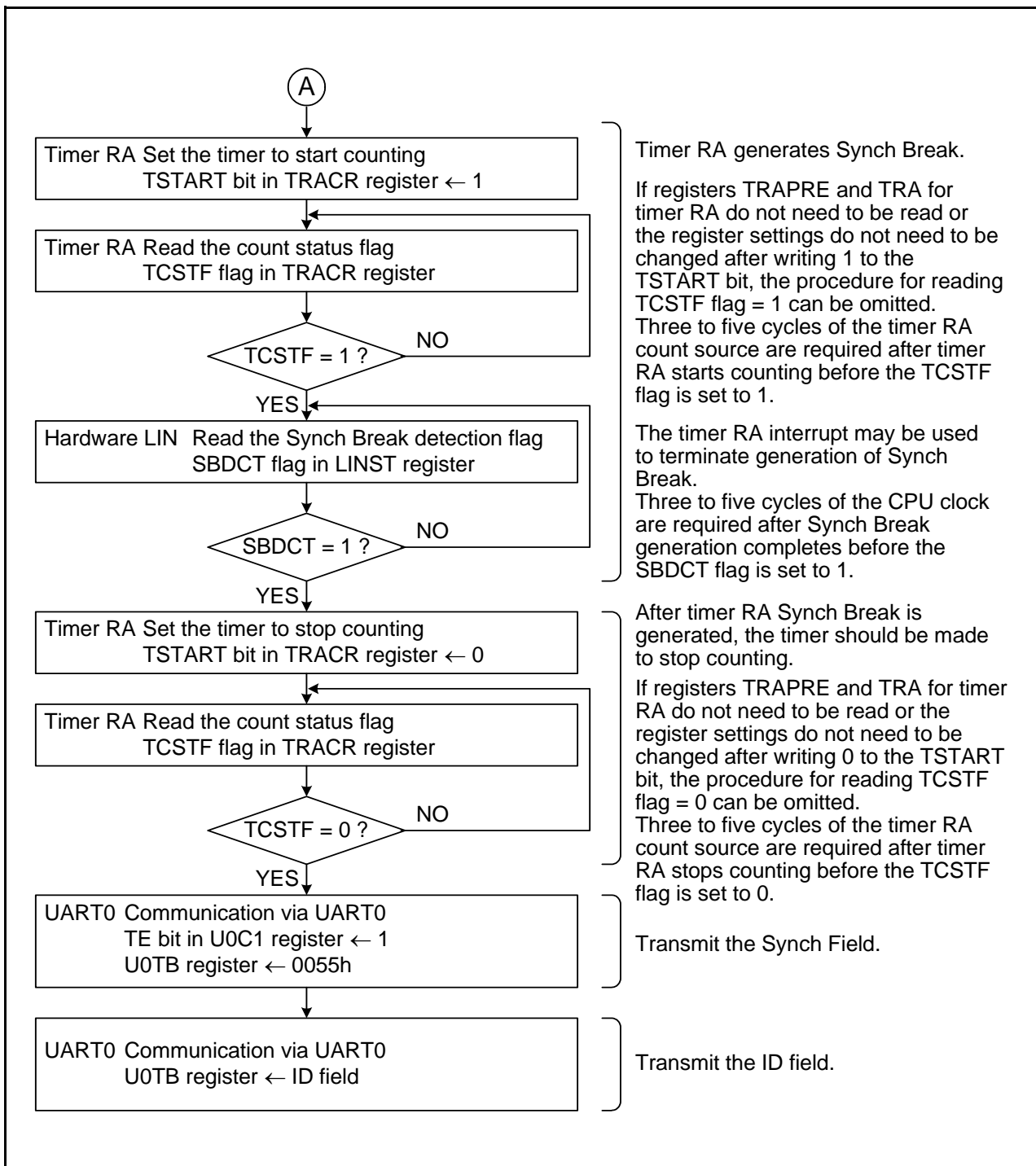

Figure 17.6 Example of Header Field Transmission Flowchart (2)

17.4.2 Slave Mode

Figure 17.7 shows typical operation of the hardware LIN when receiving a header field in slave mode. Figure 17.8 through Figure 17.10 show a flowchart for the procedure for receiving a header field.

When receiving a header field, the hardware LIN operates as described below.

- (1) Synch Break detection is enabled by writing 1 to the LSTART bit in the LINCR register of the hardware LIN.
- (2) When “L” level is input for a duration equal to or greater than the period set in timer RA, the hardware LIN detects it as Synch Break. At this time, the SBDCT flag in the LINST register is set to 1. Furthermore, if the SBIE bit in the LINCR register is set to 1, the hardware LIN generates a timer RA interrupt. Then it goes to Synch Field measurement.
- (3) The hardware LIN receives a Synch Field (55h). At this time, it measures the period of the start bit and bits 0 to 6 by using timer RA. In this case, it is possible to select whether to input the Synch Field signal to RXD0 of UART0 by setting the SBE bit in the LINCR register accordingly.
- (4) The hardware LIN sets the SFDCT flag in the LINST register to 1 when it finishes measuring the Synch Field. Furthermore, if the SFIE bit in the LINCR register is set to 1, it generates a timer RA interrupt.
- (5) After it finishes measuring the Synch Field, calculate a transfer rate from the count value of timer RA and set to UART0 and registers TRAPRE and TRA of timer RA again.
- (6) The hardware LIN performs communication for a response field after it finishes receiving the ID field.

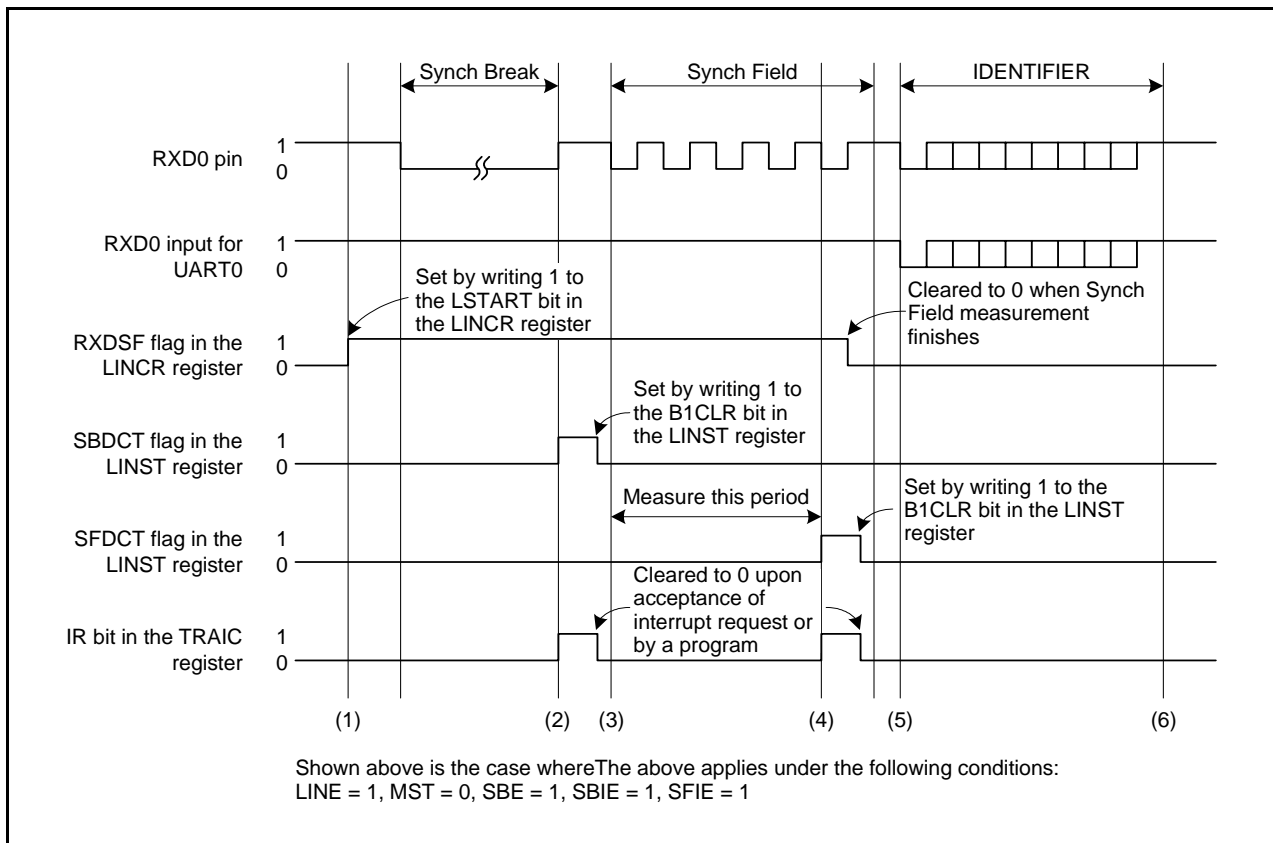

Figure 17.7 Typical Operation when Receiving a Header Field

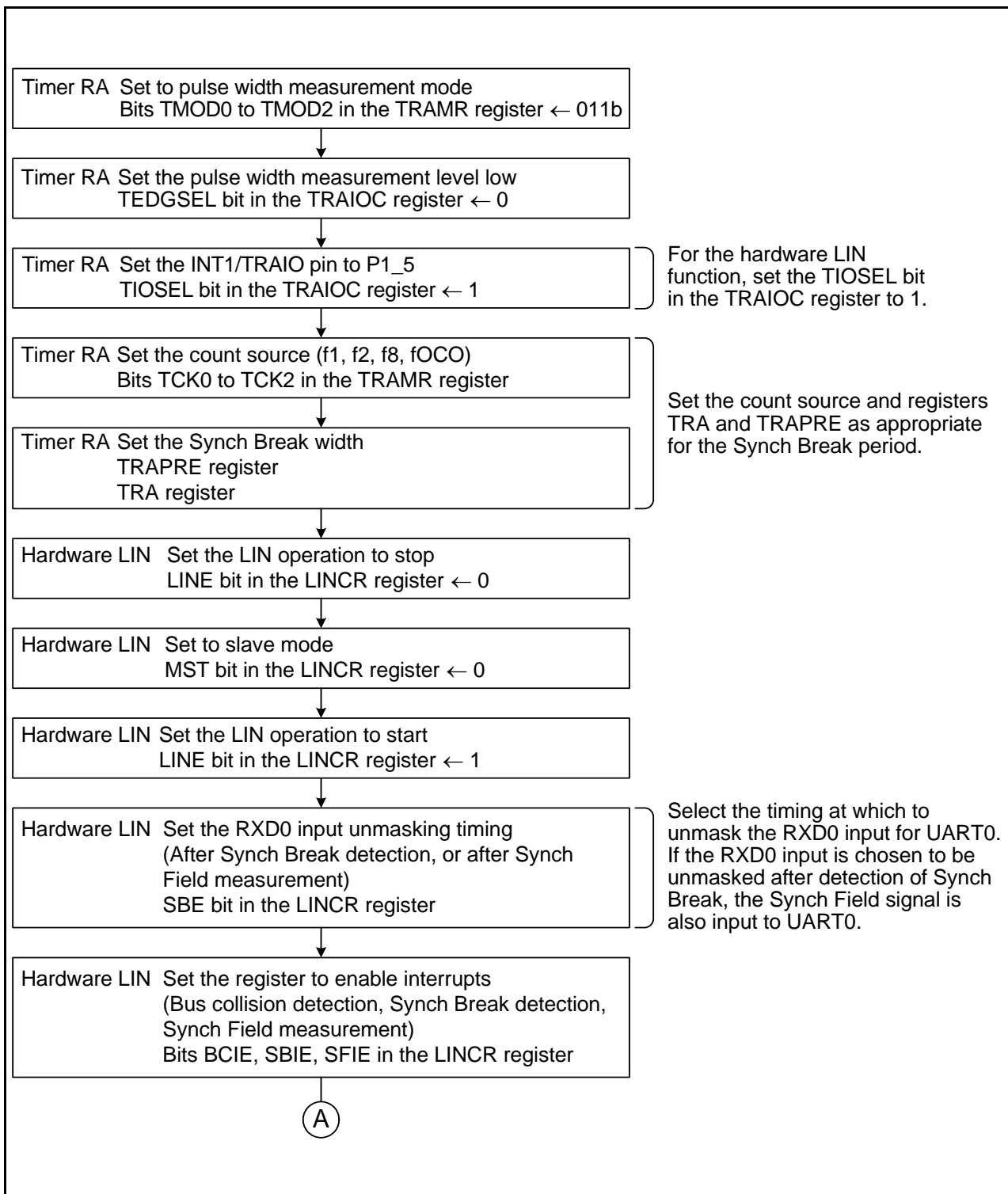

Figure 17.8 Example of Header Field Reception Flowchart (1)

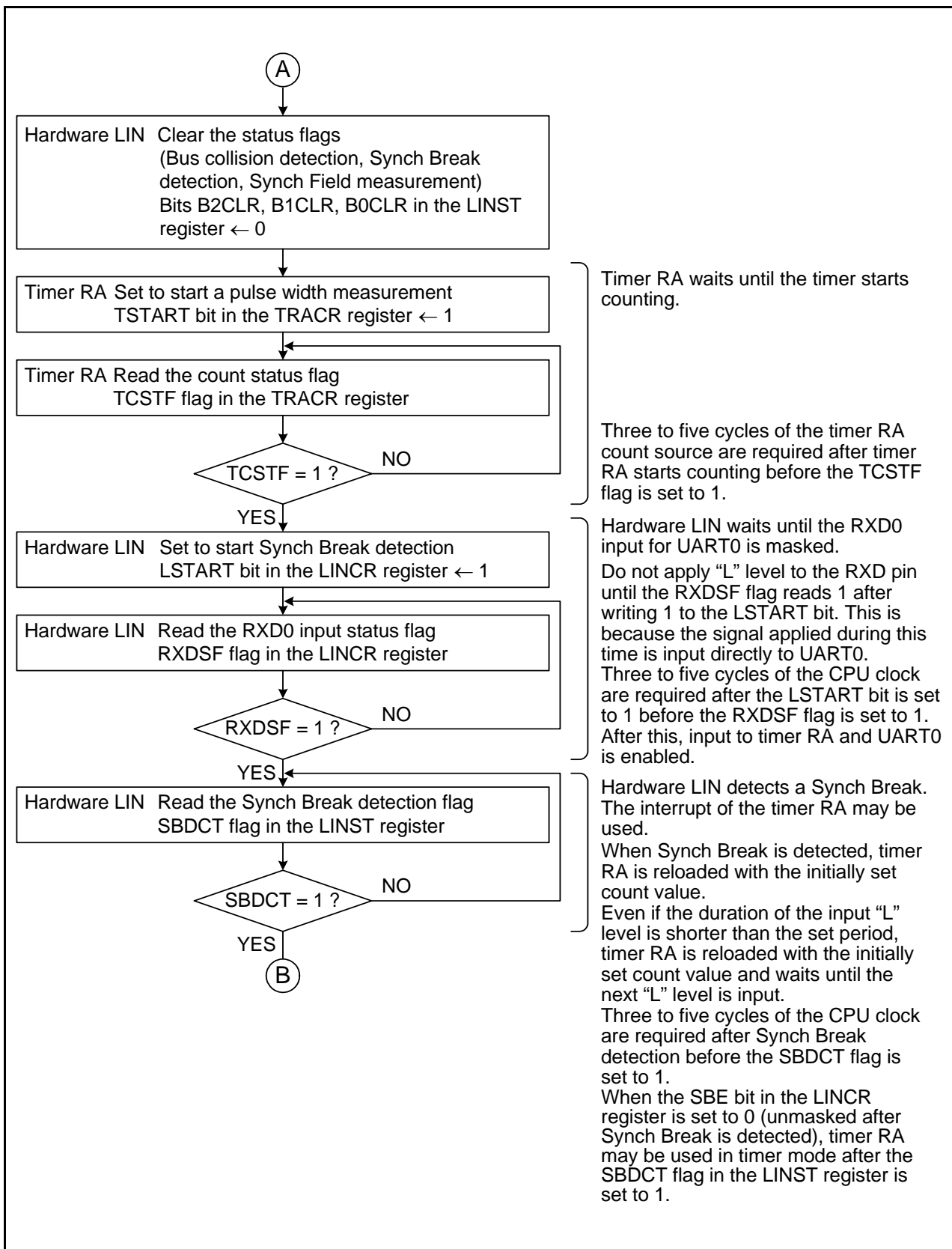

Figure 17.9 Example of Header Field Reception Flowchart (2)

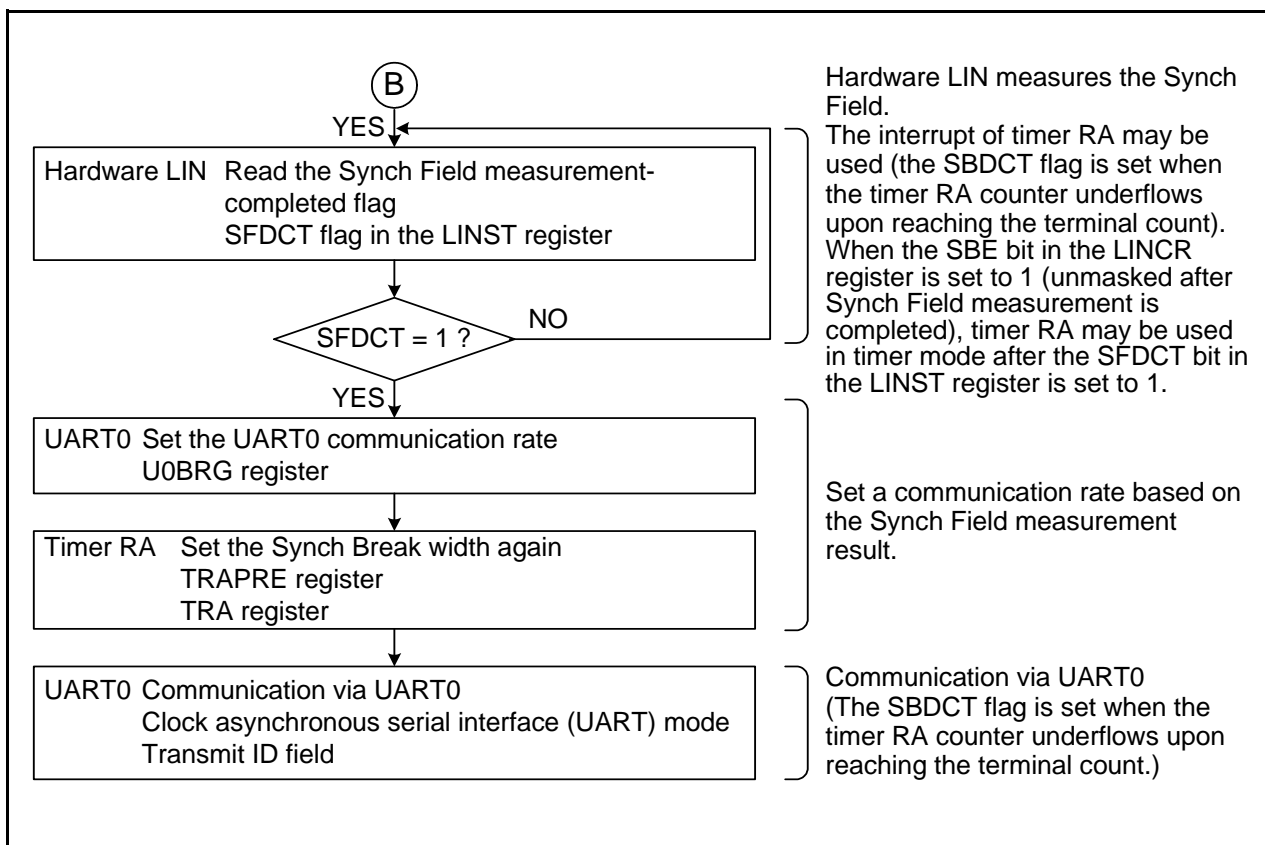

Figure 17.10 Example of Header Field Reception Flowchart (3)

17.4.3 Bus Collision Detection Function

The bus collision detection function can be used when UART0 is enabled for transmission (TE bit in the U0C1 register = 1).

Figure 17.11 shows typical operation of the hardware LIN when a bus collision is detected.

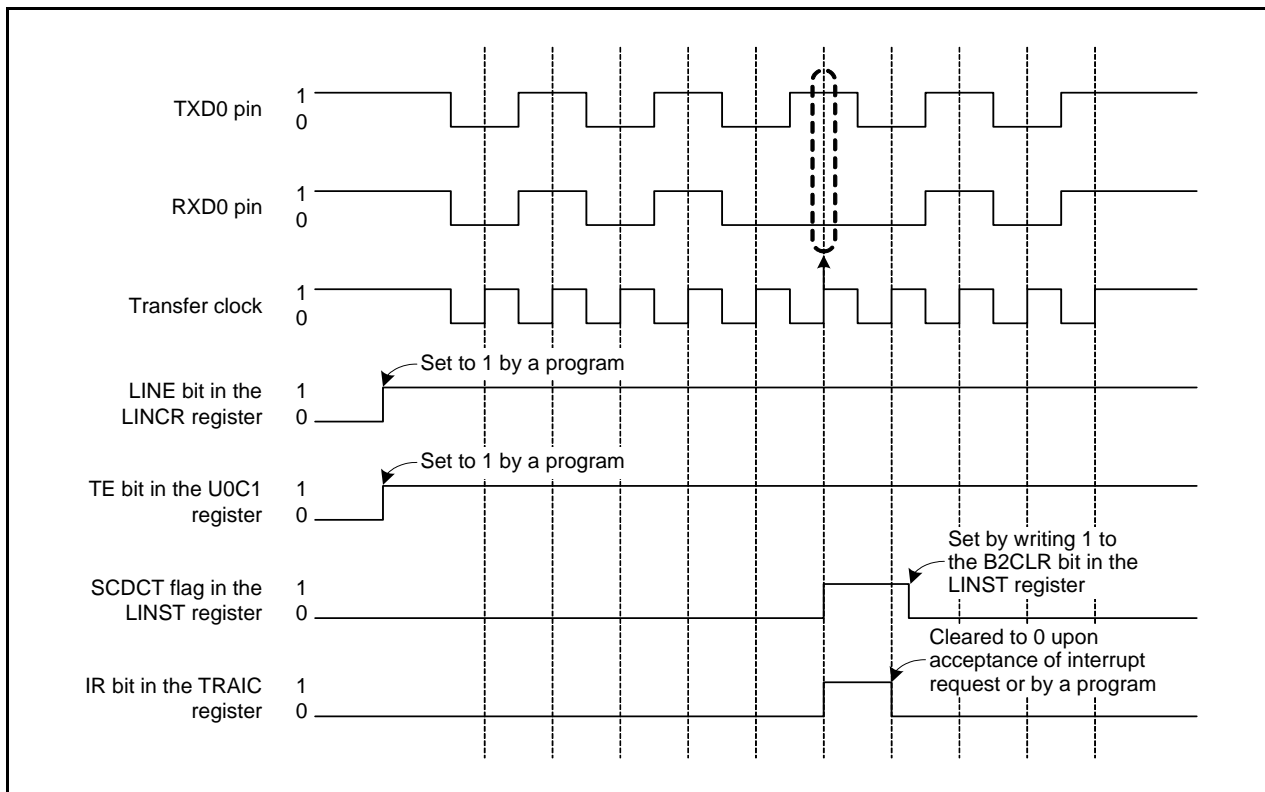

Figure 17.11 Typical Operation when a Bus Collision is Detected

17.4.4 Hardware LIN End Processing

Figure 17.12 shows an Example of Hardware LIN Communication Completion Flowchart.

Use the following timing for hardware LIN end processing:

- If the hardware bus collision detection function is used
Perform hardware LIN end processing after checksum transmission completes.
- If the bus collision detection function is not used
Perform hardware LIN end processing after header field transmission and reception complete.

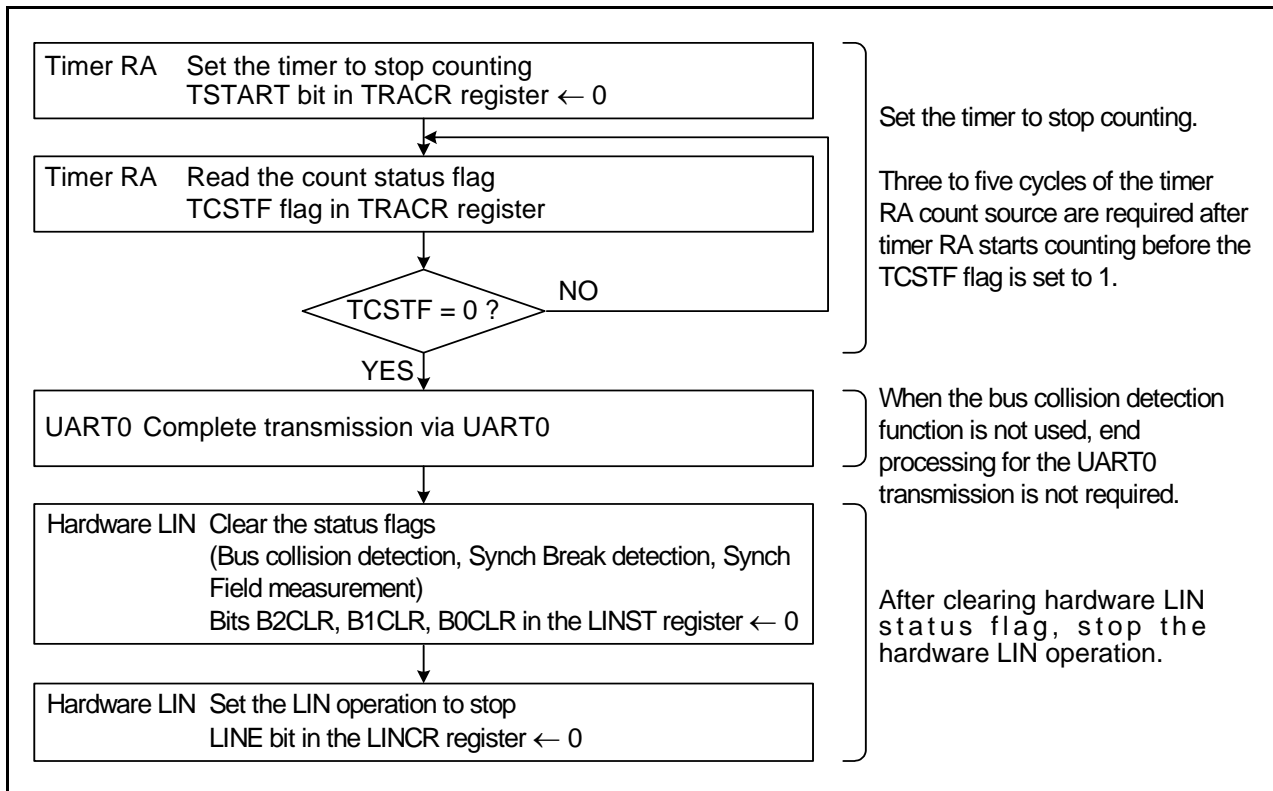

Figure 17.12 Example of Hardware LIN Communication Completion Flowchart

17.5 Interrupt Requests

There are four interrupt requests that are generated by the hardware LIN: Synch Break detection, Synch Break generation completed, Synch Field measurement, and bus collision detection. These interrupts are shared with timer RA.

Table 17.2 lists the Interrupt Requests of Hardware LIN.

Table 17.2 Interrupt Requests of Hardware LIN

Interrupt Request	Status Flag	Cause of Interrupt
Synch Break detection	SBDCT	Generated when timer RA has underflowed after measuring the "L" level duration of RXD0 input, or when a "L" level is input for a duration longer than the Synch Break period during communication.
Synch Break generation completed		Generated when "L" level output to TXD0 for the duration set by timer RA completes.
Synch Field measurement	SFDCT	Generated when measurement for 6 bits of the Synch Field by timer RA is completed.
Bus collision detection	BCDCT	Generated when the RXD0 input and TXD0 output values differed at data latch timing while UART0 is enabled for transmission.

17.6 Notes on Hardware LIN

For the time-out processing of the header and response fields, use another timer to measure the duration of time with a Synch Break detection interrupt as the starting point.

18. A/D Converter

The A/D converter consists of one 10-bit successive approximation A/D converter circuit with a capacitive coupling amplifier. The analog input shares pins P0_0 to P0_7, and P1_0 to P1_3. Therefore, when using these pins, ensure that the corresponding port direction bits are set to 0 (input mode).

When not using the A/D converter, set the VCUT bit in the ADCON1 register to 0 (Vref unconnected) so that no current will flow from the VREF pin into the resistor ladder. This helps to reduce the power consumption of the chip.

The result of A/D conversion is stored in the AD register.

Table 18.1 lists the Performance of A/D converter. Figure 18.1 shows a Block Diagram of A/D Converter.

Figures 18.2 and 18.3 show the A/D converter-related registers.

Table 18.1 Performance of A/D converter

Item	Performance
A/D conversion method	Successive approximation (with capacitive coupling amplifier)
Analog input voltage ⁽¹⁾	0 V to AVCC
Operating clock ϕ_{AD} ⁽²⁾	$4.2\text{ V} \leq AVCC \leq 5.5\text{ V}$ f1, f2, f4, fOCO-F $2.2\text{ V} \leq AVCC < 4.2\text{ V}$ f2, f4, fOCO-F
Resolution	8 bits or 10 bits selectable
Absolute accuracy	$AVCC = V_{ref} = 5\text{ V}$, $\phi_{AD} = 10\text{ MHz}$ <ul style="list-style-type: none"> • 8-bit resolution $\pm 2\text{ LSB}$ • 10-bit resolution $\pm 3\text{ LSB}$ $AVCC = V_{ref} = 3.3\text{ V}$, $\phi_{AD} = 10\text{ MHz}$ <ul style="list-style-type: none"> • 8-bit resolution $\pm 2\text{ LSB}$ • 10-bit resolution $\pm 5\text{ LSB}$ $AVCC = V_{ref} = 2.2\text{ V}$, $\phi_{AD} = 5\text{ MHz}$ <ul style="list-style-type: none"> • 8-bit resolution $\pm 2\text{ LSB}$ • 10-bit resolution $\pm 5\text{ LSB}$
Operating mode	One-shot and repeat ⁽³⁾
Analog input pin	12 pins (AN0 to AN11)
A/D conversion start condition	<ul style="list-style-type: none"> • Software trigger Set the ADST bit in the ADCON0 register to 1 (A/D conversion starts) • Capture Timer RD interrupt request is generated while the ADST bit is set to 1
Conversion rate per pin	<ul style="list-style-type: none"> • Without sample and hold function 8-bit resolution: $49\phi_{AD}$ cycles, 10-bit resolution: $59\phi_{AD}$ cycles • With sample and hold function 8-bit resolution: $28\phi_{AD}$ cycles, 10-bit resolution: $33\phi_{AD}$ cycles

NOTES:

1. The analog input voltage does not depend on use of a sample and hold function.
When the analog input voltage is over the reference voltage, the A/D conversion result will be 3FFh in 10-bit mode and FFh in 8-bit mode.
2. When $2.7\text{ V} \leq AVCC \leq 5.5\text{ V}$, the frequency of ϕ_{AD} must be 10 MHz or below.
When $2.2\text{ V} \leq AVCC < 2.7\text{ V}$, the frequency of ϕ_{AD} must be 5 MHz or below.
Without a sample and hold function, the ϕ_{AD} frequency should be 250 kHz or above.
With a sample and hold function, the ϕ_{AD} frequency should be 1 MHz or above.
3. In repeat mode, only 8-bit mode can be used.

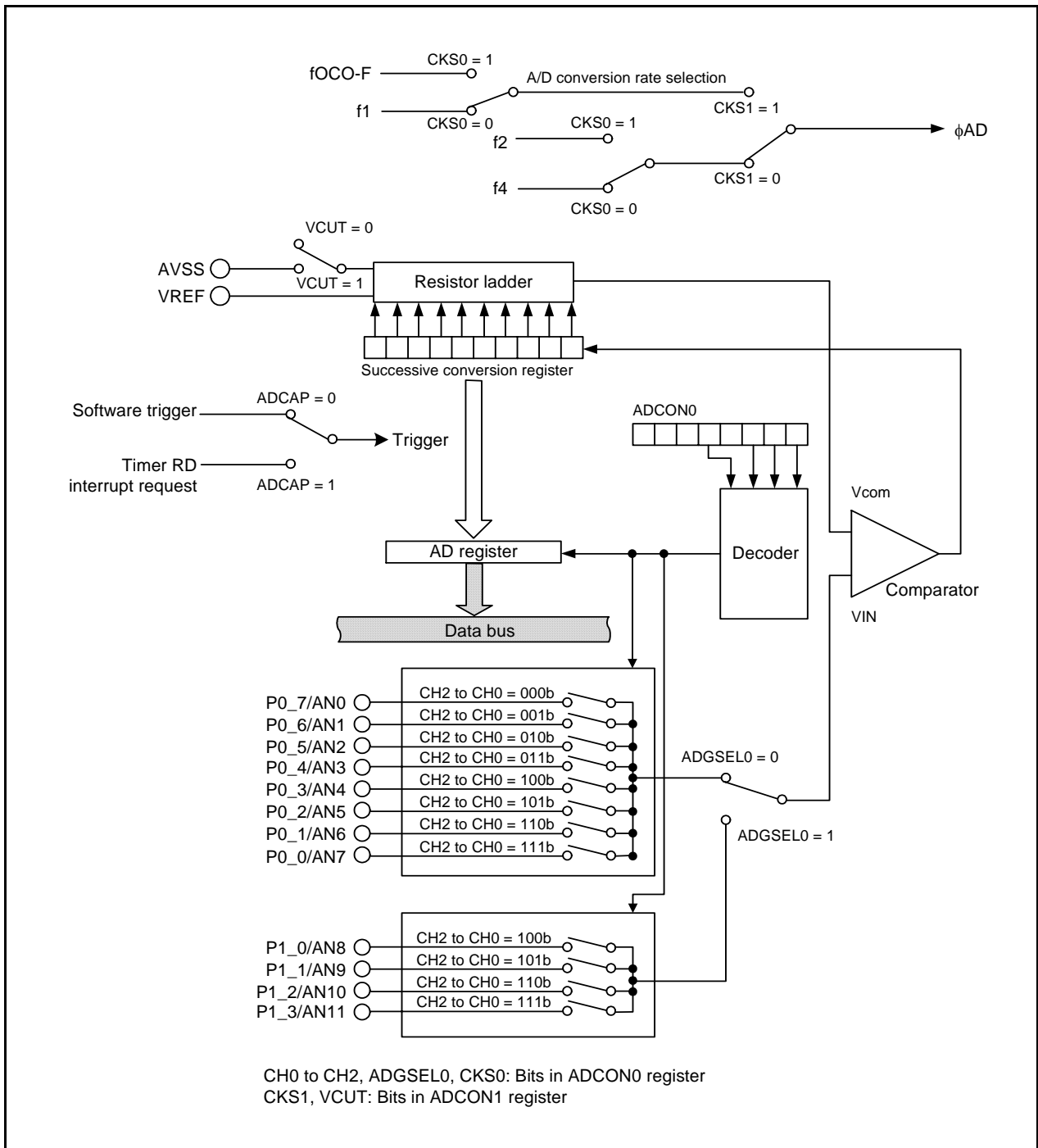

Figure 18.1 Block Diagram of A/D Converter

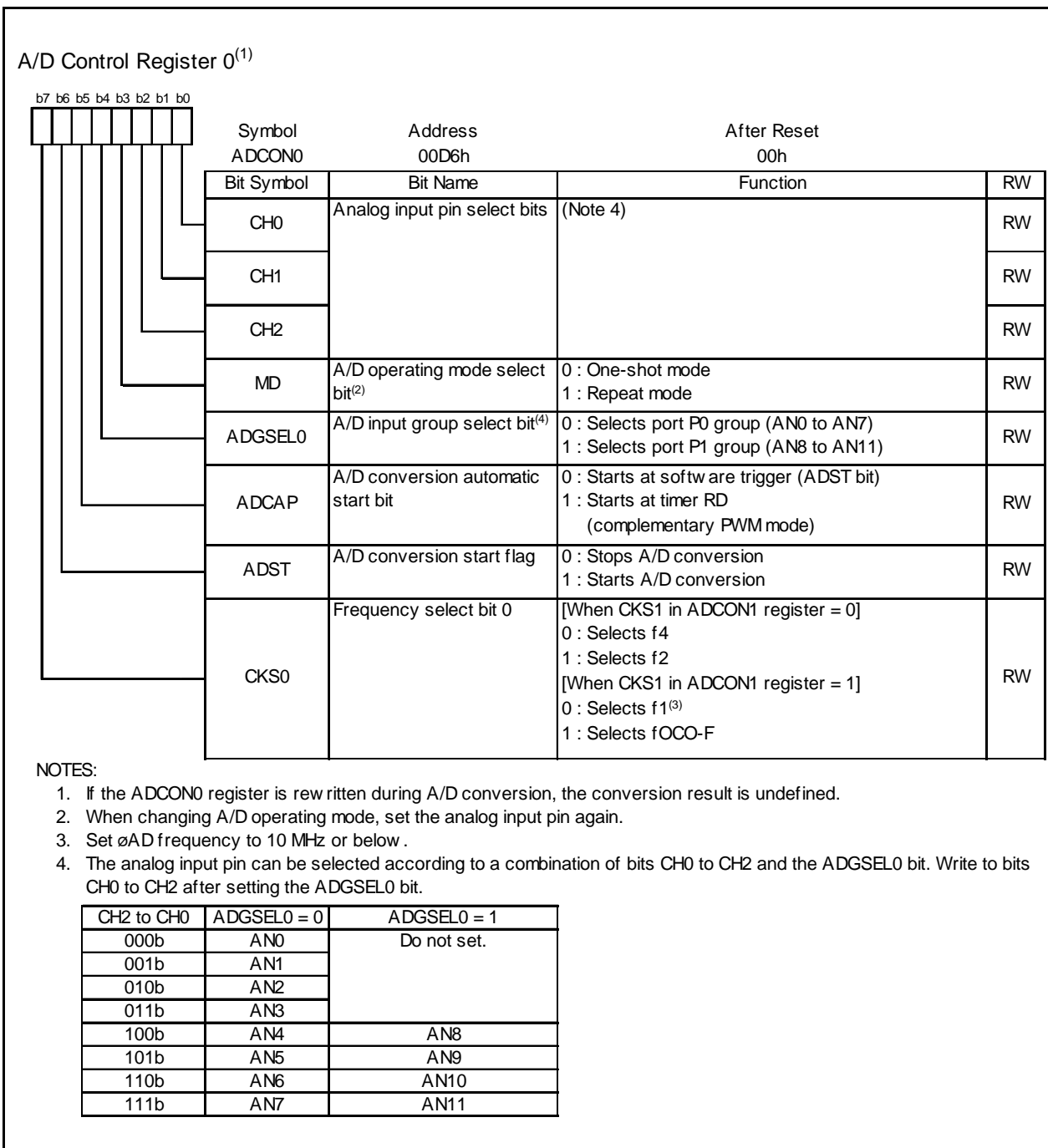

Figure 18.2 ADCON0 Register

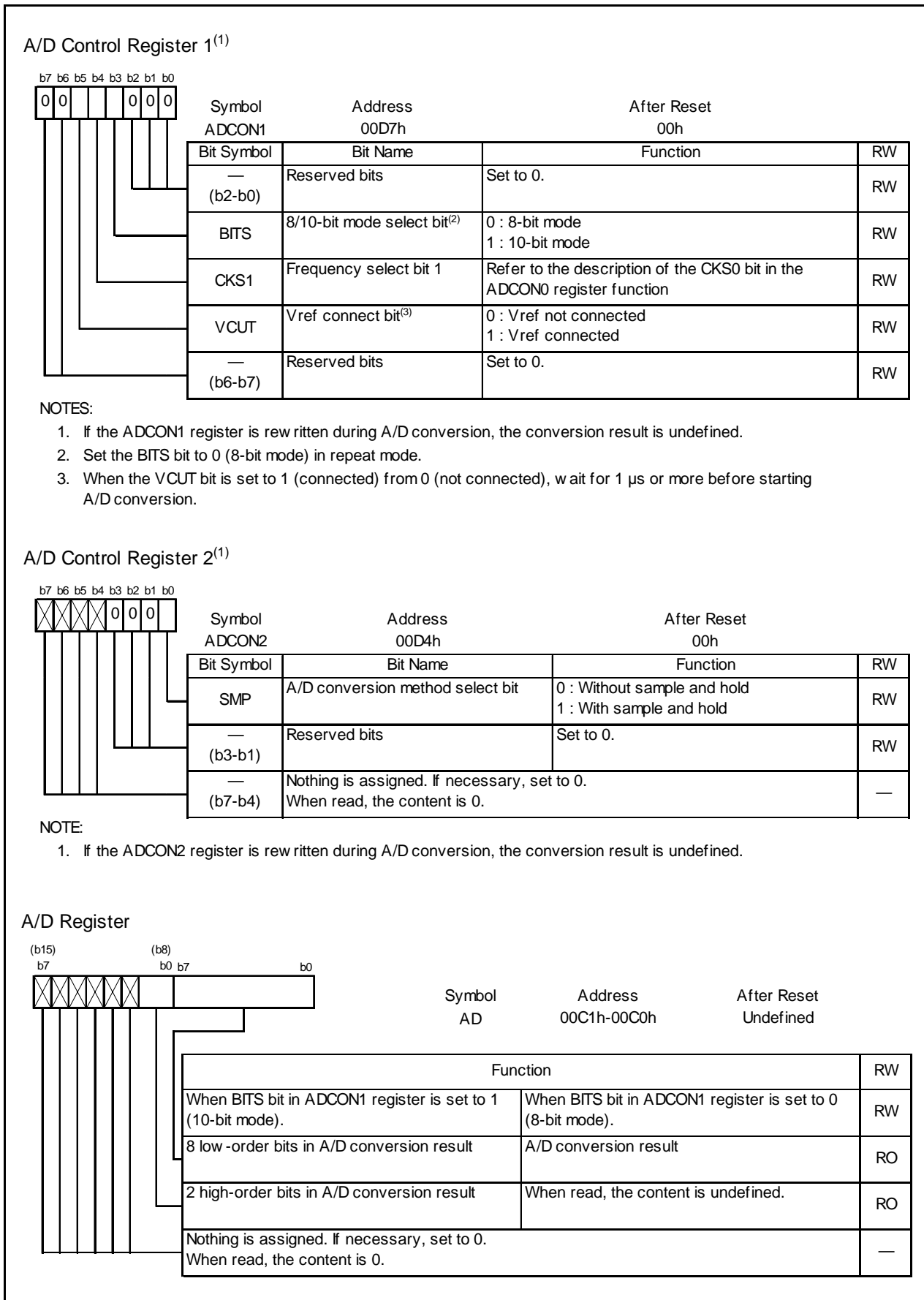

Figure 18.3 Registers ADCON1, ADCON2, and AD

18.1 One-Shot Mode

In one-shot mode, the input voltage of one selected pin is A/D converted once.

Table 18.2 lists the One-Shot Mode Specifications. Figures 18.4 and 18.5 show the ADCON0 Register in One-Shot Mode.

Table 18.2 One-Shot Mode Specifications

Item	Specification
Function	The input voltage of one pin selected by bits CH2 to CH0 and ADGSEL0 is A/D converted once
Start condition	<ul style="list-style-type: none"> • When the ADCAP bit is set to 0 (software trigger), set the ADST bit to 1 (A/D conversion starts) • When the ADCAP bit is set to 1 (starts in timer RD (complementary PWM mode), A compare match between registers TRD0 and TRDGRA0 or a TRD1 underflow is generated while the ADST bit is set to 1
Stop condition	<ul style="list-style-type: none"> • A/D conversion completes (when the ADCAP bit is set to 0 (software trigger) ADST bit is set to 0) • Set the ADST bit to 0
Interrupt request generation timing	A/D conversion completes
Input pin	Select one of AN0 to AN11
Reading of A/D conversion result	Read AD register

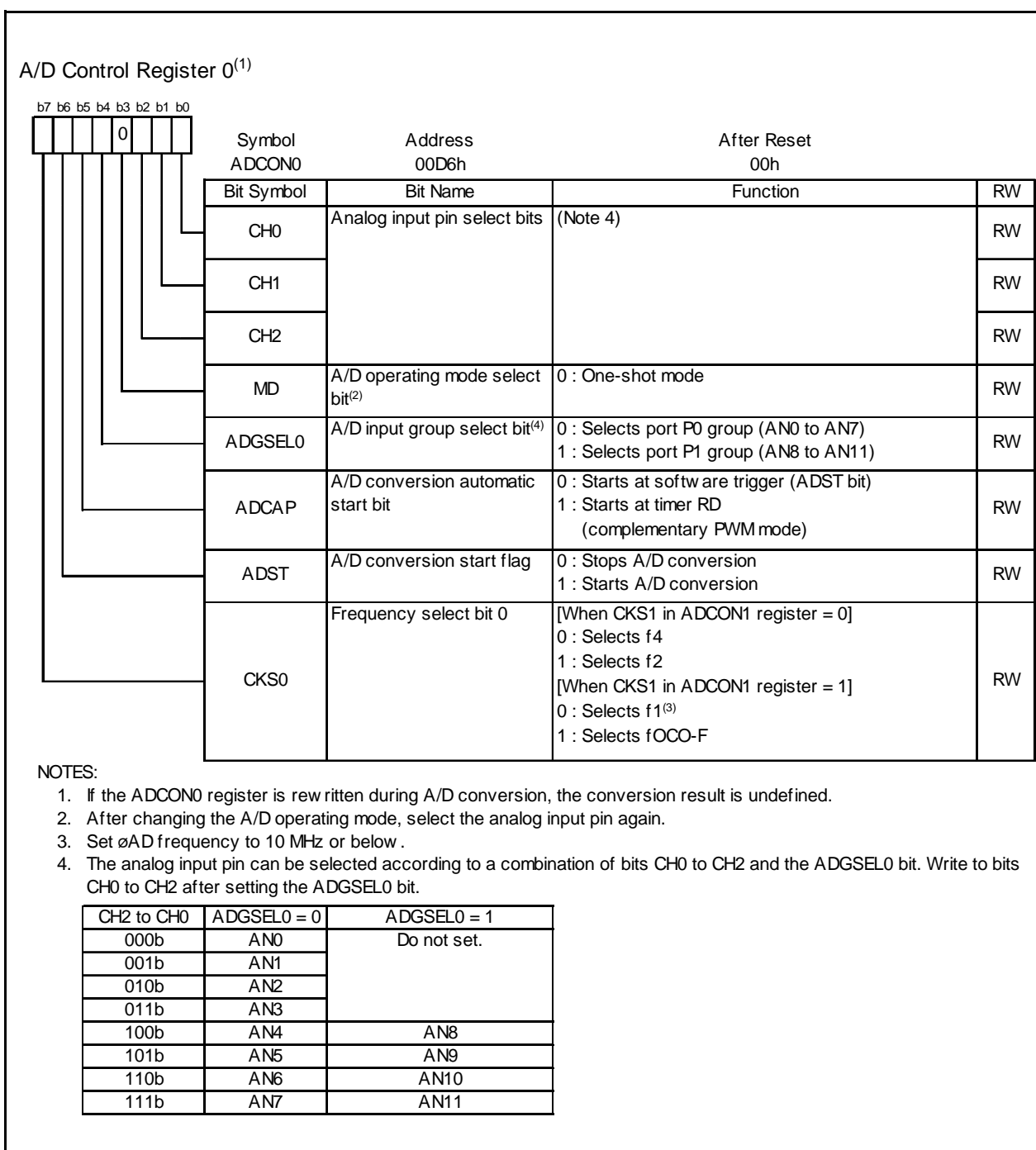

Figure 18.4 ADCON0 Register in One-Shot Mode

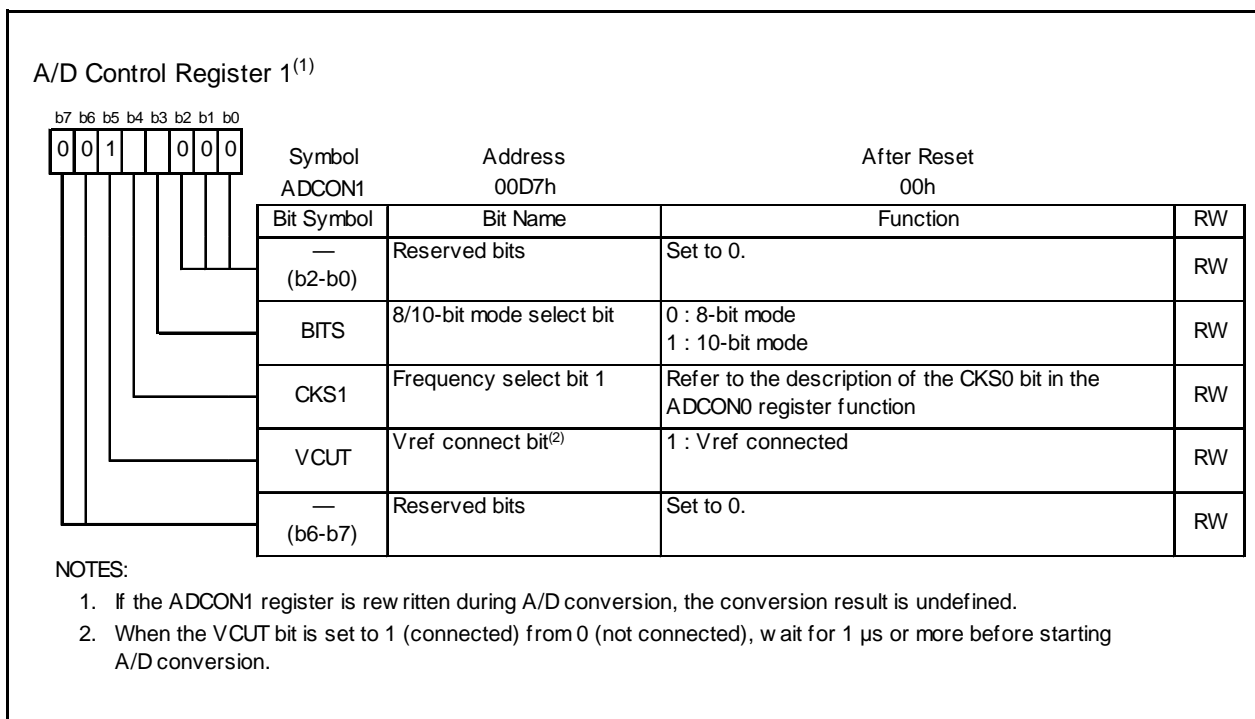

Figure 18.5 ADCON1 Register in One-Shot Mode

18.2 Repeat Mode

In repeat mode, the input voltage of one selected pin is A/D converted repeatedly.

Table 18.3 lists the Repeat Mode Specifications. Figures 18.6 and 18.7 show Registers ADCON0 and ADCON1 in Repeat Mode.

Table 18.3 Repeat Mode Specifications

Item	Specification
Function	The Input voltage of one pin selected by bits CH2 to CH0 and ADGSEL0 is A/D converted repeatedly
Start conditions	<ul style="list-style-type: none"> • When the ADCAP bit is set to 0 (software trigger), set the ADST bit to 1 (A/D conversion starts) • When the ADCAP bit is set to 1 (starts in timer RD (complementary PWM mode)), a compare match between registers TRD0 and TRDGRA0 or a TRD1 underflow is generated while the ADST bit is set to 1
Stop condition	Set the ADST bit to 0
Interrupt request generation timing	Not generated
Input pin	Select one of AN0 to AN11
Reading of result of A/D converter	Read AD register

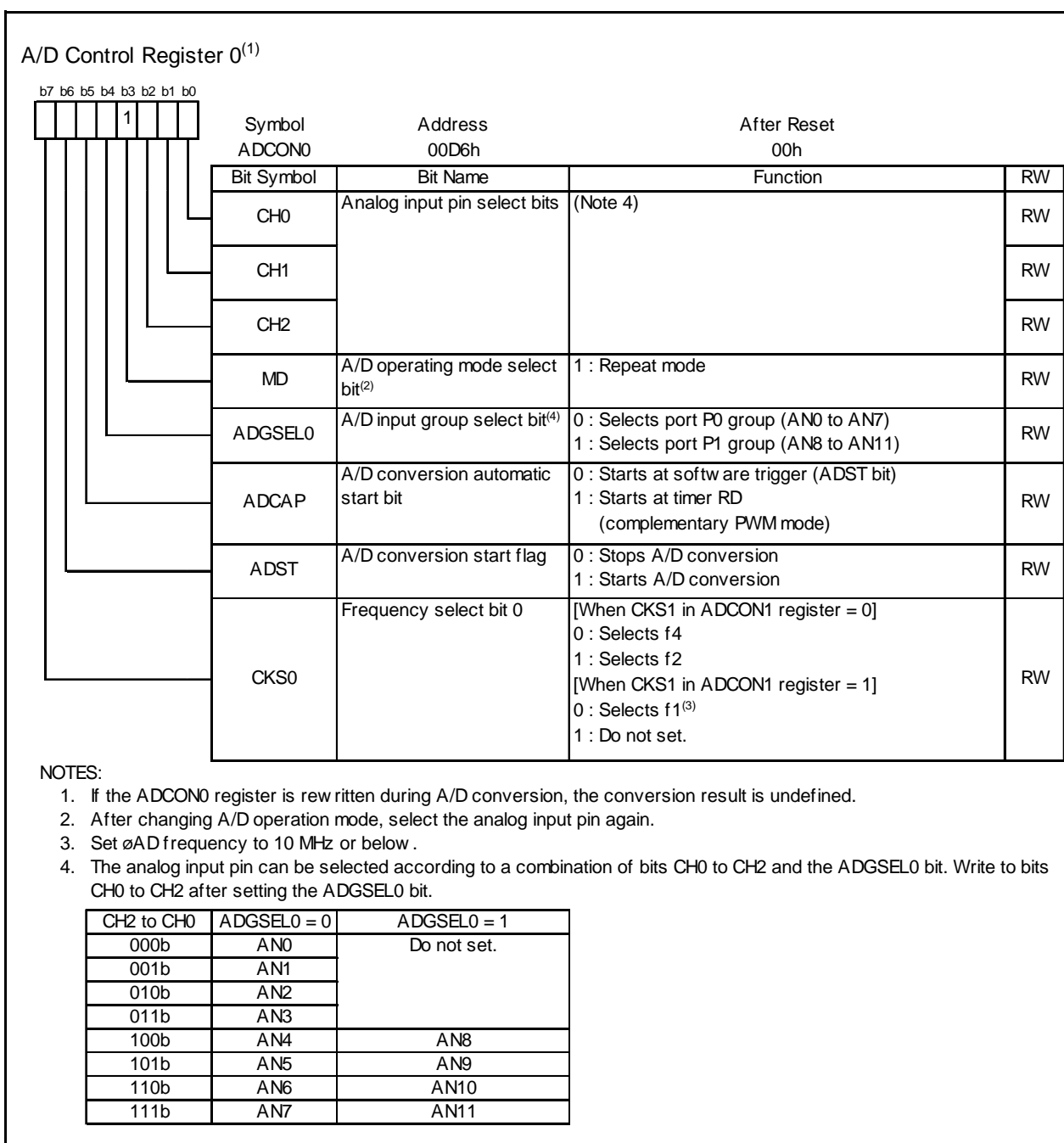

Figure 18.6 ADCON0 Register in Repeat Mode

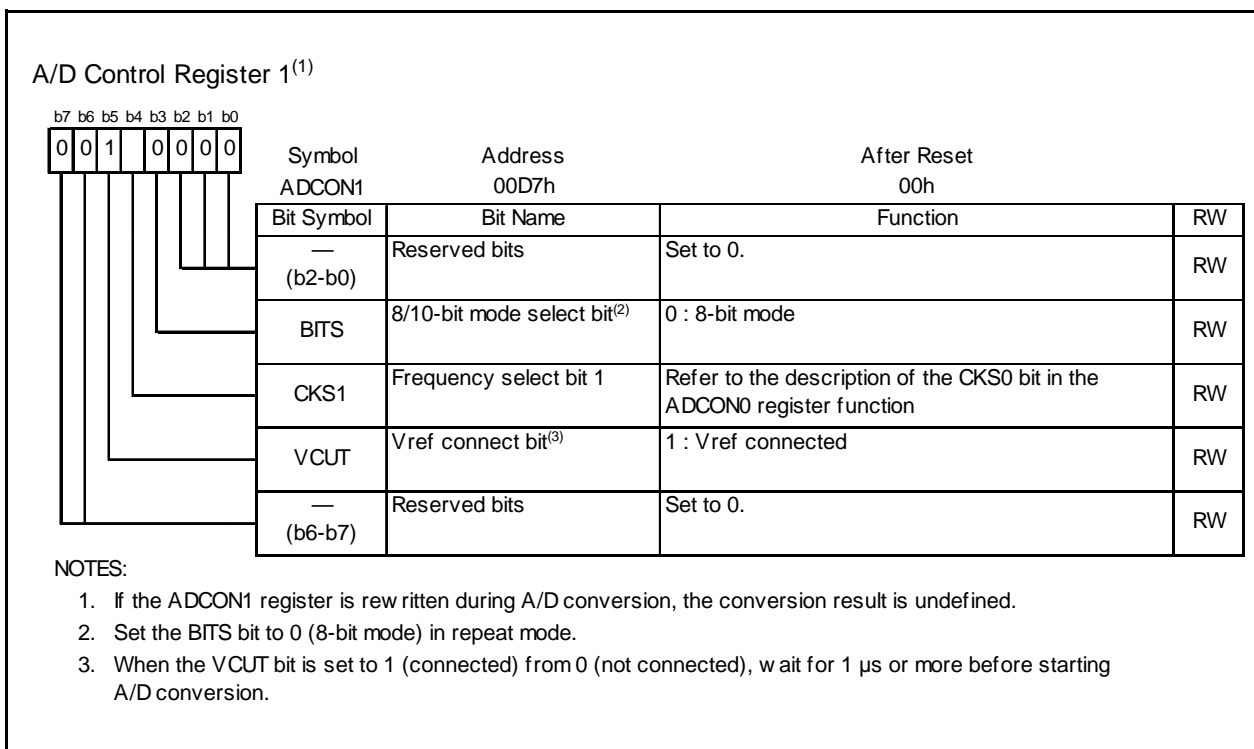

Figure 18.7 ADCON1 Register in Repeat Mode

18.3 Sample and Hold

When the SMP bit in the ADCON2 register is set to 1 (sample and hold function enabled), the A/D conversion rate per pin increases. The sample and hold function is available in all operating modes. Start A/D conversion after selecting whether the sample and hold circuit is to be used or not.

Figure 18.8 shows a Timing Diagram of A/D Conversion.

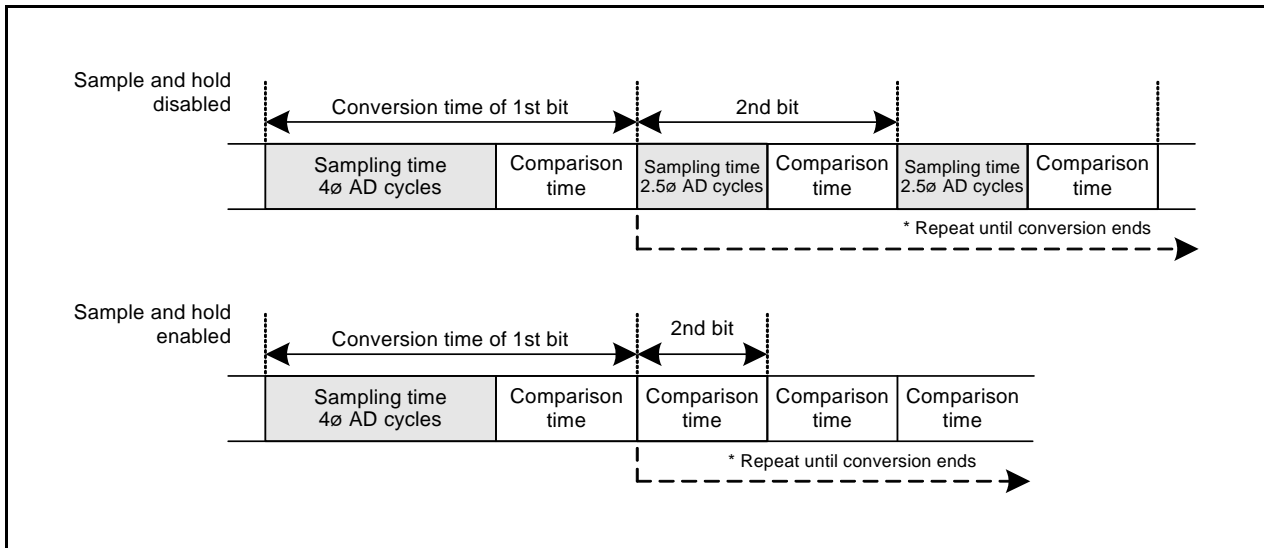

Figure 18.8 Timing Diagram of A/D Conversion

18.4 A/D Conversion Cycles

Figure 18.9 shows the A/D Conversion Cycles.

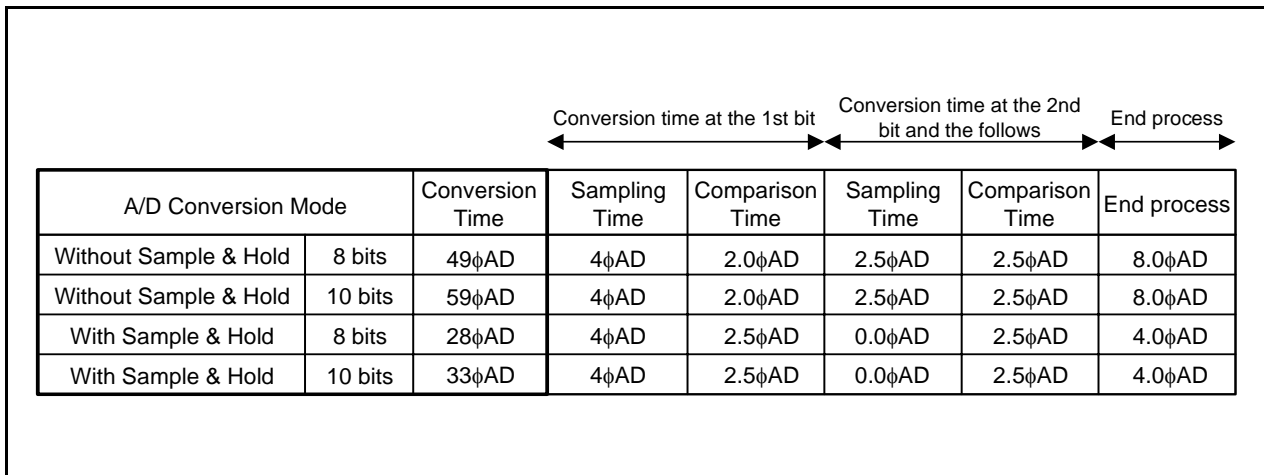

Figure 18.9 A/D Conversion Cycles

18.5 Internal Equivalent Circuit of Analog Input

Figure 18.10 shows the Internal Equivalent Circuit of Analog Input.

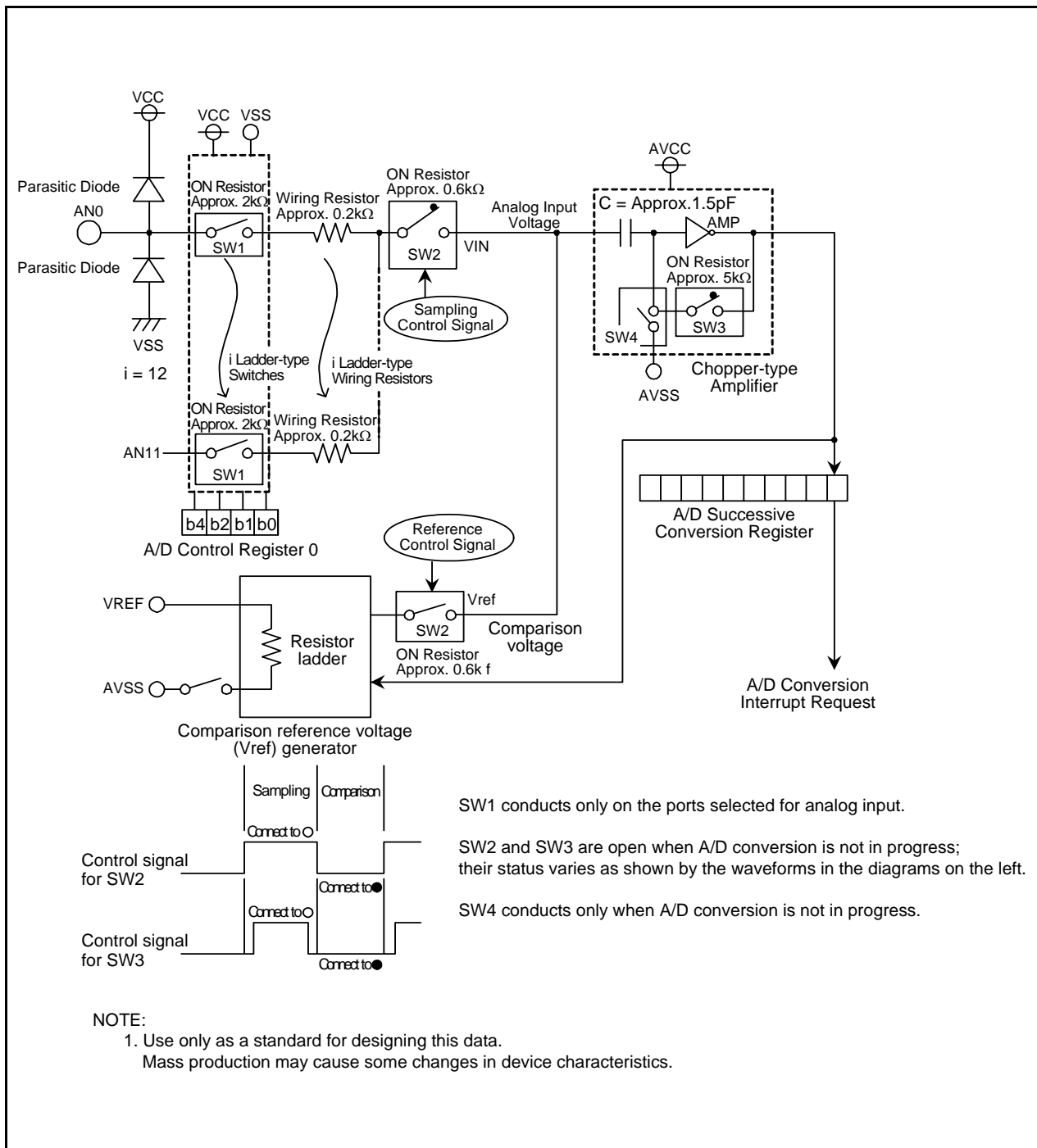

Figure 18.10 Internal Equivalent Circuit of Analog Input

18.6 Output Impedance of Sensor under A/D Conversion

To carry out A/D conversion properly, charging the internal capacitor C shown in Figure 18.11 has to be completed within a specified period of time. T (sampling time) as the specified time. Let output impedance of sensor equivalent circuit be R0, internal resistance of microcomputer be R, precision (error) of the A/D converter be X, and the resolution of A/D converter be Y (Y is 1024 in the 10-bit mode, and 256 in the 8-bit mode).

$$VC \text{ is generally } VC = VIN \left\{ 1 - e^{-\frac{1}{C(R0 + R)} t} \right\}$$

$$\text{And when } t = T, \quad VC = VIN - \frac{X}{Y} VIN = VIN \left(1 - \frac{X}{Y} \right)$$

$$e^{-\frac{1}{C(R0 + R)} T} = \frac{X}{Y}$$

$$-\frac{1}{C(R0 + R)} T = \ln \frac{X}{Y}$$

$$\text{Hence, } R0 = -\frac{T}{C \cdot \ln \frac{X}{Y}} - R$$

Figure 18.11 shows Analog Input Pin and External Sensor Equivalent Circuit. When the difference between VIN and VC becomes 0.1LSB, we find impedance R0 when voltage between pins VC changes from 0 to VIN - (0.1/1024) VIN in time T. (0.1/1024) means that A/D precision drop due to insufficient capacitor charge is held to 0.1LSB at time of A/D conversion in the 10-bit mode. Actual error however is the value of absolute precision added to 0.1LSB.

When $f(XIN) = 10 \text{ MHz}$, $T = 0.25 \mu\text{s}$ in the A/D conversion mode without sample & hold. Output impedance R0 for sufficiently charging capacitor C within time T is determined as follows.

$T = 0.25 \mu\text{s}$, $R = 2.8 \text{ k}\Omega$, $C = 6.0 \text{ pF}$, $X = 0.1$, and $Y = 1024$. Hence,

$$R0 = \frac{0.25 \times 10^{-6}}{6.0 \times 10^{-12} \cdot \ln \frac{0.1}{1024}} - 2.8 \times 10^3 \approx 1.7 \times 10^3$$

Thus, the allowable output impedance of the sensor equivalent circuit, making the precision (error) 0.1LSB or less, is approximately 1.7 kΩ maximum.

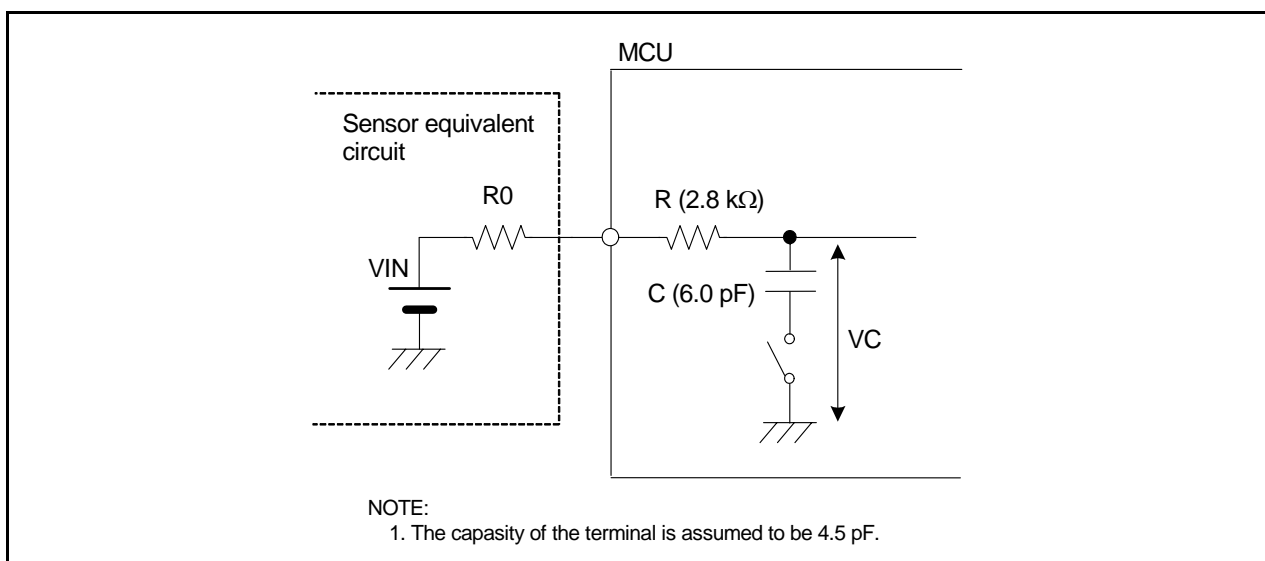

Figure 18.11 Analog Input Pin and External Sensor Equivalent Circuit

18.7 Notes on A/D Converter

- Write to each bit (other than bit 6) in the ADCON0 register, each bit in the ADCON1 register, or the SMP bit in the ADCON2 register when A/D conversion is stopped (before a trigger occurs).
When the VCUT bit in the ADCON1 register is changed from 0 (VREF not connected) to 1 (VREF connected), wait for at least 1 μ s before starting the A/D conversion.
- After changing the A/D operating mode, select an analog input pin again.
- When using the one-shot mode, ensure that A/D conversion is completed before reading the AD register. The IR bit in the ADIC register or the ADST bit in the ADCON0 register can be used to determine whether A/D conversion is completed.
- When using the repeat mode, use the undivided XIN clock as the CPU clock. Do not select the fOCO-F for the ϕ AD.
- If the ADST bit in the ADCON0 register is set to 0 (A/D conversion stops) by a program and A/D conversion is forcibly terminated during an A/D conversion operation, the conversion result of the A/D converter will be undefined. If the ADST bit is set to 0 by a program, do not use the value of the AD register.
- Connect 0.1 μ F capacitor between the P4_2/VREF pin and AVSS pin.

19. Flash Memory

19.1 Overview

In the flash memory, rewrite operations to the flash memory can be performed in three modes: CPU rewrite, standard serial I/O, and parallel I/O.

Table 19.1 lists the Flash Memory Performance (refer to **Table 1.1 Functions and Specifications for R8C/24 Group** and **Table 1.2 Functions and Specifications for R8C/25 Group** for items not listed in Table 19.1).

Table 19.1 Flash Memory Performance

Item		Specification
Flash memory operating mode		3 modes (CPU rewrite, standard serial I/O, and parallel I/O)
Division of erase block		Refer to Figure 19.1 and Figure 19.2
Programming method		Byte unit
Erase method		Block erase
Programming and erasure control method ⁽³⁾		Program and erase control by software command
Rewrite control method		Rewrite control for blocks 0 and 1 by FMR02 bit in FMR0 register Rewrite control for block 0 by FMR15 bit and Block 1 by FMR16 bit in FMR1 register
Number of commands		5 commands
Programming and erasure endurance ⁽¹⁾	Blocks 0 and 1 (program ROM)	R8C/24 Group: 100 times; R8C/25 Group: 1,000 times
	Blocks A and B (data flash) ⁽²⁾	10,000 times
ID code check function		Standard serial I/O mode supported
ROM code protect		Parallel I/O mode supported

NOTES:

1. Definition of programming and erasure endurance

The programming and erasure endurance is defined on a per-block basis. If the programming and erasure endurance is n (n = 100 or 10,000), each block can be erased n times. For example, if 1,024 1-byte writes are performed to block A, a 1-Kbyte block, and then the block is erased, the erase count stands at one. When performing 100 or more rewrites, the actual erase count can be reduced by executing programming operations in such a way that all blank areas are used before performing an erase operation. Avoid rewriting only particular blocks and try to average out the programming and erasure endurance of the blocks. It is also advisable to retain data on the erase count of each block and limit the number of erase operations to a certain number.

2. Blocks A and B are implemented only in the R8C/25 group.

3. To perform programming and erasure, use VCC = 2.7 V to 5.5 V as the supply voltage. Do not perform programming and erasure at less than 2.7 V.

Table 19.2 Flash Memory Rewrite Modes

Flash memory Rewrite mode	CPU Rewrite Mode	Standard Serial I/O Mode	Parallel I/O Mode
Function	User ROM area is rewritten by executing software commands from the CPU. EW0 mode: Rewritable in any area other than flash memory EW1 mode: Rewritable in flash memory	User ROM area is rewritten by a dedicated serial programmer.	User ROM area is rewritten by a dedicated parallel programmer.
Areas which can be rewritten	User ROM area	User ROM area	User ROM area
Operating mode	Single chip mode	Boot mode	Parallel I/O mode
ROM Programmer	None	Serial programmer	Parallel programmer

19.2 Memory Map

The flash memory contains a user ROM area and a boot ROM area (reserved area). Figure 19.1 shows the Flash Memory Block Diagram for R8C/24 Group. Figure 19.2 shows a Flash Memory Block Diagram for R8C/25 Group. The user ROM area of the R8C/25 Group contains an area (program ROM) which stores MCU operating programs and blocks A and B (data flash) each 1 Kbyte in size.

The user ROM area is divided into several blocks. The user ROM area can be rewritten in CPU rewrite mode and standard serial I/O and parallel I/O modes.

When rewriting blocks 0 and 1 in CPU rewrite mode, set the FMR02 bit in the FMR0 register to 1 (rewrite enabled). When the FMR15 bit in the FMR1 register is set to 0 (rewrite enabled), block 0 is rewritable. When the FMR16 bit is set to 0 (rewrite enabled), block 1 is rewritable.

The rewrite control program for standard serial I/O mode is stored in the boot ROM area before shipment. The boot ROM area and the user ROM area share the same address, but have separate memory areas.

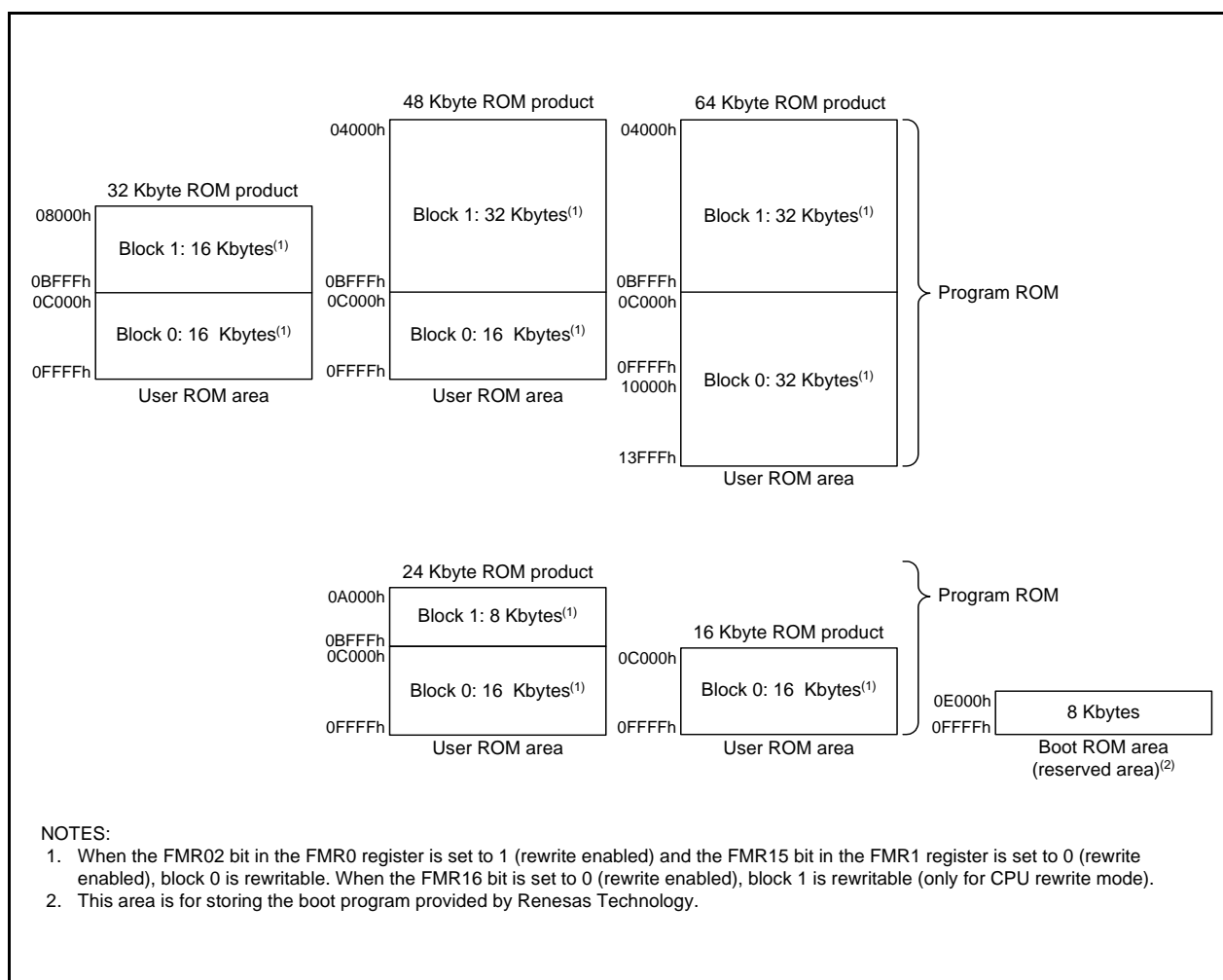

Figure 19.1 Flash Memory Block Diagram for R8C/24 Group

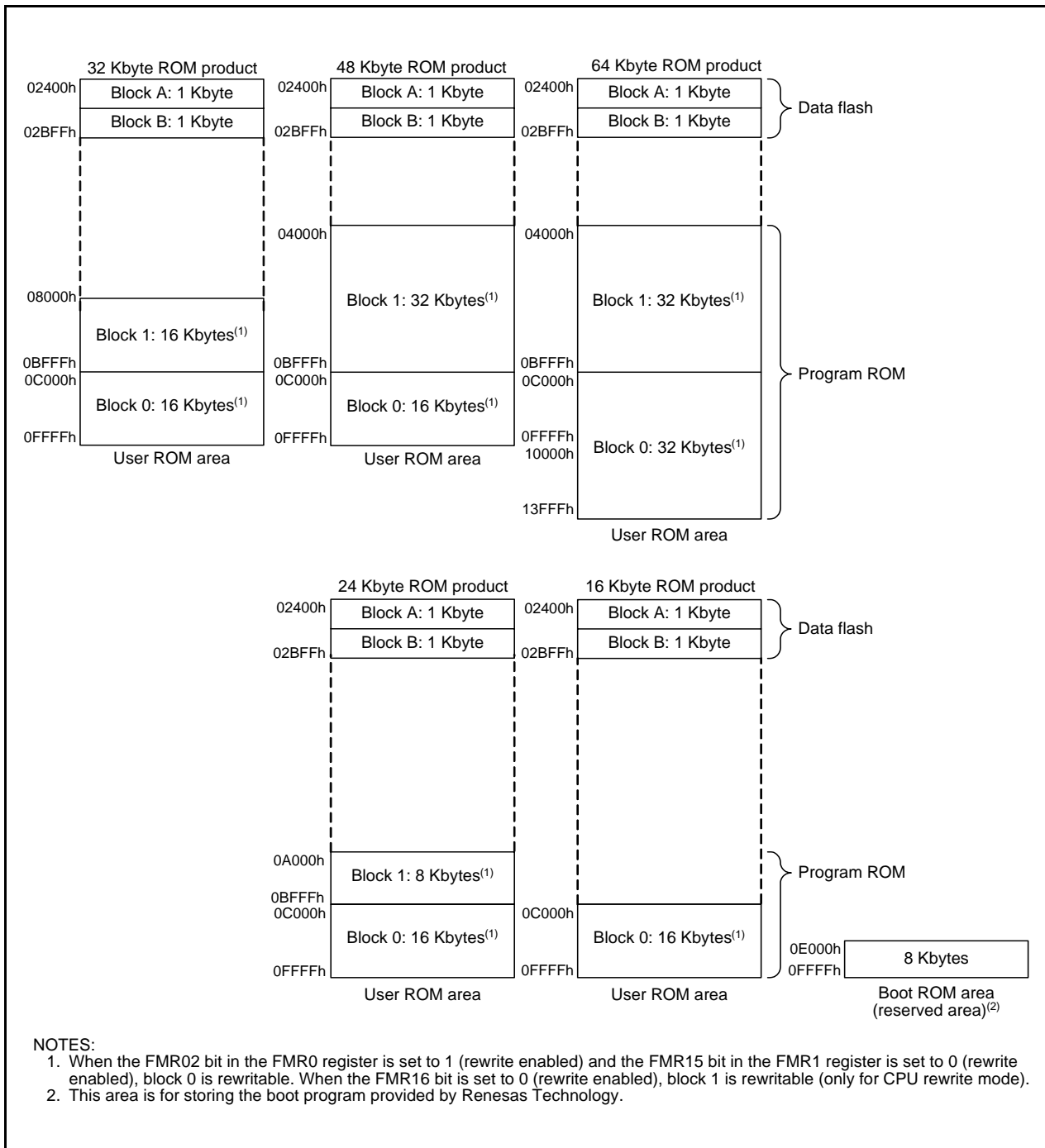

Figure 19.2 Flash Memory Block Diagram for R8C/25 Group

19.3 Functions to Prevent Rewriting of Flash Memory

Standard serial I/O mode has an ID code check function, and parallel I/O mode has a ROM code protect function to prevent the flash memory from being read or rewritten easily.

19.3.1 ID Code Check Function

This function is used in standard serial I/O mode. Unless the flash memory is blank, the ID codes sent from the programmer and the ID codes written in the flash memory are checked to see if they match. If the ID codes do not match, the commands sent from the programmer are not acknowledged. The ID codes consist of 8 bits of data each, the areas of which, beginning with the first byte, are 00FFDFh, 00FFE3h, 00FFEBh, 00FFEFh, 00FFF3h, 00FFF7h, and 00FFFBh. Write programs in which the ID codes are set at these addresses and write them to the flash memory.

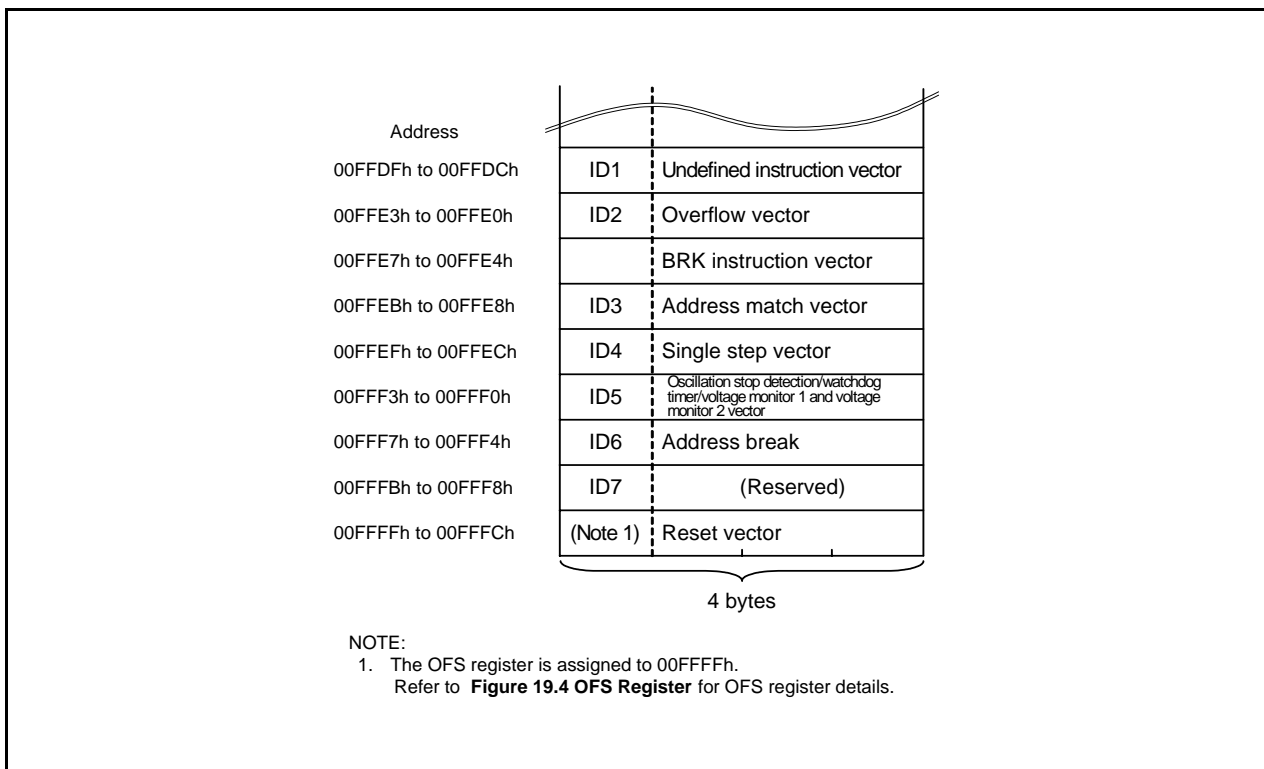

Figure 19.3 Address for Stored ID Code

19.3.2 ROM Code Protect Function

The ROM code protect function disables reading or changing the contents of the on-chip flash memory by the OFS register in parallel I/O mode. Figure 19.4 shows the OFS Register.

The ROM code protect function is enabled by writing 0 to the ROMCP1 bit and 1 to the ROMCR bit. It disables reading or changing the contents of the on-chip flash memory.

Once ROM code protect is enabled, the content in the internal flash memory cannot be rewritten in parallel I/O mode. To disable ROM code protect, erase the block including the OFS register with CPU rewrite mode or standard serial I/O mode.

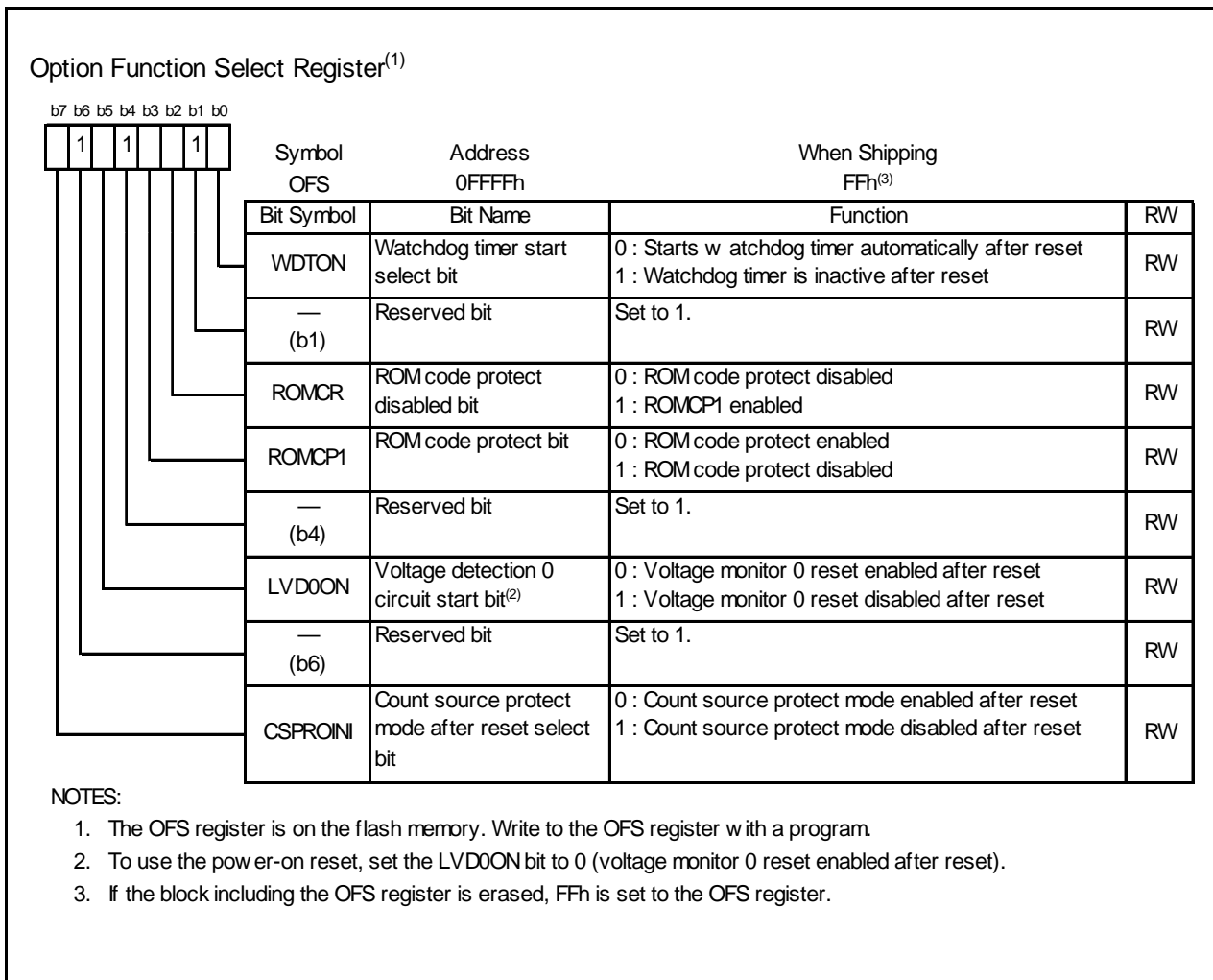

Figure 19.4 OFS Register

19.4 CPU Rewrite Mode

In CPU rewrite mode, the user ROM area can be rewritten by executing software commands from the CPU. Therefore, the user ROM area can be rewritten directly while the MCU is mounted on a board without using a ROM programmer. Execute the program and block erase commands only to blocks in the user ROM area.

The flash module has an erase-suspend function when an interrupt request is generated during an erase operation in CPU rewrite mode. It performs an interrupt process after the erase operation is halted temporarily. During erase-suspend, the user ROM area can be read by a program.

In case an interrupt request is generated during an auto-program operation in CPU rewrite mode, the flash module has a program-suspend function which performs the interrupt process after the auto-program operation is suspended. During program-suspend, the user ROM area can be read by a program.

CPU rewrite mode has an erase write 0 mode (EW0 mode) and an erase write 1 mode (EW1 mode). Table 19.3 lists the Differences between EW0 Mode and EW1 Mode.

Table 19.3 Differences between EW0 Mode and EW1 Mode

Item	EW0 Mode	EW1 Mode
Operating mode	Single-chip mode	Single-chip mode
Areas in which a rewrite control program can be located	User ROM area	User ROM area
Areas in which a rewrite control program can be executed	Necessary to transfer to any area other than the flash memory (e.g., RAM) before executing	Executing directly in user ROM area is possible
Areas which can be rewritten	User ROM area	User ROM area However, blocks which contain a rewrite control program are excluded ⁽¹⁾
Software command restrictions	None	<ul style="list-style-type: none"> • Program and block erase commands • Cannot be run on any block which contains a rewrite control program • Read status register command cannot be executed
Modes after program or erase	Read status register mode	Read array mode
Modes after read status register	Read status register mode	Do not execute this command
CPU status during auto-write and auto-erase	Operating	Hold state (I/O ports hold state before the command is executed)
Flash memory status detection	<ul style="list-style-type: none"> • Read bits FMR00, FMR06, and FMR07 in the FMR0 register by a program • Execute the read status register command and read bits SR7, SR5, and SR4 in the status register. 	Read bits FMR00, FMR06, and FMR07 in the FMR0 register by a program
Conditions for transition to erase-suspend	Set bits FMR40 and FMR41 in the FMR4 register to 1 by a program.	The FMR40 bit in the FMR4 register is set to 1 and the interrupt request of the enabled maskable interrupt is generated
Conditions for transitions to program-suspend	Set bits FMR40 and FMR42 in the FMR4 register to 1 by a program.	The FMR40 bit in the FMR4 register is set to 1 and the interrupt request of the enabled maskable interrupt is generated
CPU clock	5 MHz or below	No restriction (on clock frequency to be used)

NOTE:

1. When the FMR02 bit in the FMR0 register is set to 1 (rewrite enabled), rewriting block 0 is enabled by setting the FMR15 bit in the FMR1 register to 0 (rewrite enabled), and rewriting block 1 is enabled by setting the FMR16 bit to 0 (rewrite enabled).

19.4.1 EW0 Mode

The MCU enters CPU rewrite mode and software commands can be acknowledged by setting the FMR01 bit in the FMR0 register to 1 (CPU rewrite mode enabled). In this case, since the FMR11 bit in the FMR1 register is set to 0, EW0 mode is selected.

Use software commands to control program and erase operations. The FMR0 register or the status register can be used to determine when program and erase operations complete.

During auto-erasure, set the FMR40 bit to 1 (erase-suspend enabled) and the FMR41 bit to 1 (request erase-suspend). Wait for td(SR-ES) and ensure that the FMR46 bit is set to 1 (read enabled) before accessing the user ROM area. The auto-erase operation can be restarted by setting the FMR41 bit to 0 (erase restarts).

To enter program-suspend during the auto-program operation, set the FMR40 bit to 1 (suspend enabled) and the FMR42 bit to 1 (request program-suspend). Wait for td(SR-ES) and ensure that the FMR46 bit is set to 1 (read enabled) before accessing the user ROM area. The auto-program operation can be restarted by setting the FMR42 bit to 0 (program restarts).

19.4.2 EW1 Mode

The MCU is switched to EW1 mode by setting the FMR11 bit to 1 (EW1 mode) after setting the FMR01 bit to 1 (CPU rewrite mode enabled).

The FMR0 register can be used to determine when program and erase operations complete. Do not execute commands that use the read status register in EW1 mode.

To enable the erase-suspend function during auto-erasure, execute the block erase command after setting the FMR40 bit to 1 (erase-suspend enabled). The interrupt to enter erase-suspend should be in interrupt enabled status. After waiting for td(SR-ES) after the block erase command is executed, the interrupt request is acknowledged.

When an interrupt request is generated, the FMR41 bit is automatically set to 1 (requests erase-suspend) and the auto-erase operation suspends. If an auto-erase operation does not complete (FMR00 bit is 0) after an interrupt process completes, the auto-erase operation restarts by setting the FMR41 bit to 0 (erasure restarts)

To enable the program-suspend function during auto-programming, execute the program command after setting the FMR40 bit to 1 (suspend enabled). The interrupt to enter program-suspend should be in interrupt enabled status. After waiting for td(SR-ES) after the program command is executed, an interrupt request is acknowledged.

When an interrupt request is generated, the FMR42 bit is automatically set to 1 (request program-suspend) and the auto-program operation suspends. When the auto-program operation does not complete (FMR00 bit is 0) after the interrupt process completes, the auto-program operation can be restarted by setting the FMR42 bit to 0 (programming restarts).

Figure 19.5 shows the FMR0 Register. Figure 19.7 shows the FMR4 Register.

19.4.2.1 FMR00 Bit

This bit indicates the operating status of the flash memory. The bit's value is 0 during programming, erasure (including suspend periods), or erase-suspend mode; otherwise, it is 1.

19.4.2.2 FMR01 Bit

The MCU is made ready to accept commands by setting the FMR01 bit to 1 (CPU rewrite mode).

19.4.2.3 FMR02 Bit

Rewriting of blocks 0 and 1 does not accept program or block erase commands if the FMR02 bit is set to 0 (rewrite disabled).

Rewriting of blocks 0 and 1 is controlled by bits FMR15 and FMR16 if the FMR02 bit is set to 1 (rewrite enabled).

19.4.2.4 FMSTP Bit

This bit is used to initialize the flash memory control circuits, and also to reduce the amount of current consumed by the flash memory. Access to the flash memory is disabled by setting the FMSTP bit to 1. Therefore, the FMSTP bit must be written to by a program located outside of the flash memory.

In the following cases, set the FMSTP bit to 1:

- When flash memory access resulted in an error while erasing or programming in EW0 mode (FMR00 bit not reset to 1 (ready))
- To provide lower consumption in high-speed on-chip oscillator mode, low-speed on-chip oscillator mode (XIN clock stops), and low-speed clock mode (XIN clock stops).

Figure 19.11 shows the handling to provide lower consumption in high-speed on-chip oscillator mode, low-speed on-chip oscillator mode (XIN clock stops), and low-speed clock mode (XIN clock stops). Handle according to this flowchart. Note that when going to stop or wait mode while the CPU rewrite mode is disabled, the FMR0 register does not need to be set because the power for the flash memory is automatically turned off and is turned back on again after returning from stop or wait mode.

19.4.2.5 FMR06 Bit

This is a read-only bit indicating the status of an auto-program operation. The bit is set to 1 when a program error occurs; otherwise, it is set to 0. For details, refer to the description in **19.4.5 Full Status Check**.

19.4.2.6 FMR07 Bit

This is a read-only bit indicating the status of an auto-erase operation. The bit is set to 1 when an erase error occurs; otherwise, it is set to 0. Refer to **19.4.5 Full Status Check** for details.

19.4.2.7 FMR11 Bit

Setting this bit to 1 (EW1 mode) places the MCU in EW1 mode.

19.4.2.8 FMR15 Bit

When the FMR02 bit is set to 1 (rewrite enabled) and the FMR15 bit is set to 0 (rewrite enabled), block 0 accepts program and block erase commands.

19.4.2.9 FMR16 Bit

When the FMR02 bit is set to 1 (rewrite enabled) and the FMR16 bit is set to 0 (rewrite enabled), block 1 accepts program and block erase commands.

19.4.2.10 FMR40 Bit

The suspend function is enabled by setting the FMR40 bit to 1 (enable).

19.4.2.11 FMR41 Bit

In EW0 mode, the MCU enters erase-suspend mode when the FMR41 bit is set to 1 by a program. The FMR41 bit is automatically set to 1 (request erase-suspend) when an interrupt request of an enabled interrupt is generated in EW1 mode, and then the MCU enters erase-suspend mode.

Set the FMR41 bit to 0 (erase restarts) when the auto-erase operation restarts.

19.4.2.12 FMR42 Bit

In EW0 mode, the MCU enters program-suspend mode when the FMR42 bit is set to 1 by a program. The FMR42 bit is automatically set to 1 (request program-suspend) when an interrupt request of an enabled interrupt is generated in EW1 mode, and then the MCU enters program-suspend mode.

Set the FMR42 bit to 0 (program restart) when the auto-program operation restarts.

19.4.2.13 FMR43 Bit

When the auto-erase operation starts, the FMR43 bit is set to 1 (erase execution in progress). The FMR43 bit remains set to 1 (erase execution in progress) during erase-suspend operation.

When the auto-erase operation ends, the FMR43 bit is set to 0 (erase not executed).

19.4.2.14 FMR44 Bit

When the auto-program operation starts, the FMR44 bit is set to 1 (program execution in progress). The FMR44 bit remains set to 1 (program execution in progress) during program-suspend operation.

When the auto-program operation ends, the FMR44 bit is set to 0 (program not executed).

19.4.2.15 FMR46 Bit

The FMR46 bit is set to 0 (reading disabled) during auto-erase execution and set to 1 (reading enabled) in erase-suspend mode. Do not access the flash memory while this bit is set to 0.

19.4.2.16 FMR47 Bit

Power consumption when reading the flash memory can be reduced by setting the FMR47 bit to 1 (enabled) in low-speed clock mode (XIN clock stops) and low-speed on-chip oscillator mode (XIN clock stops).

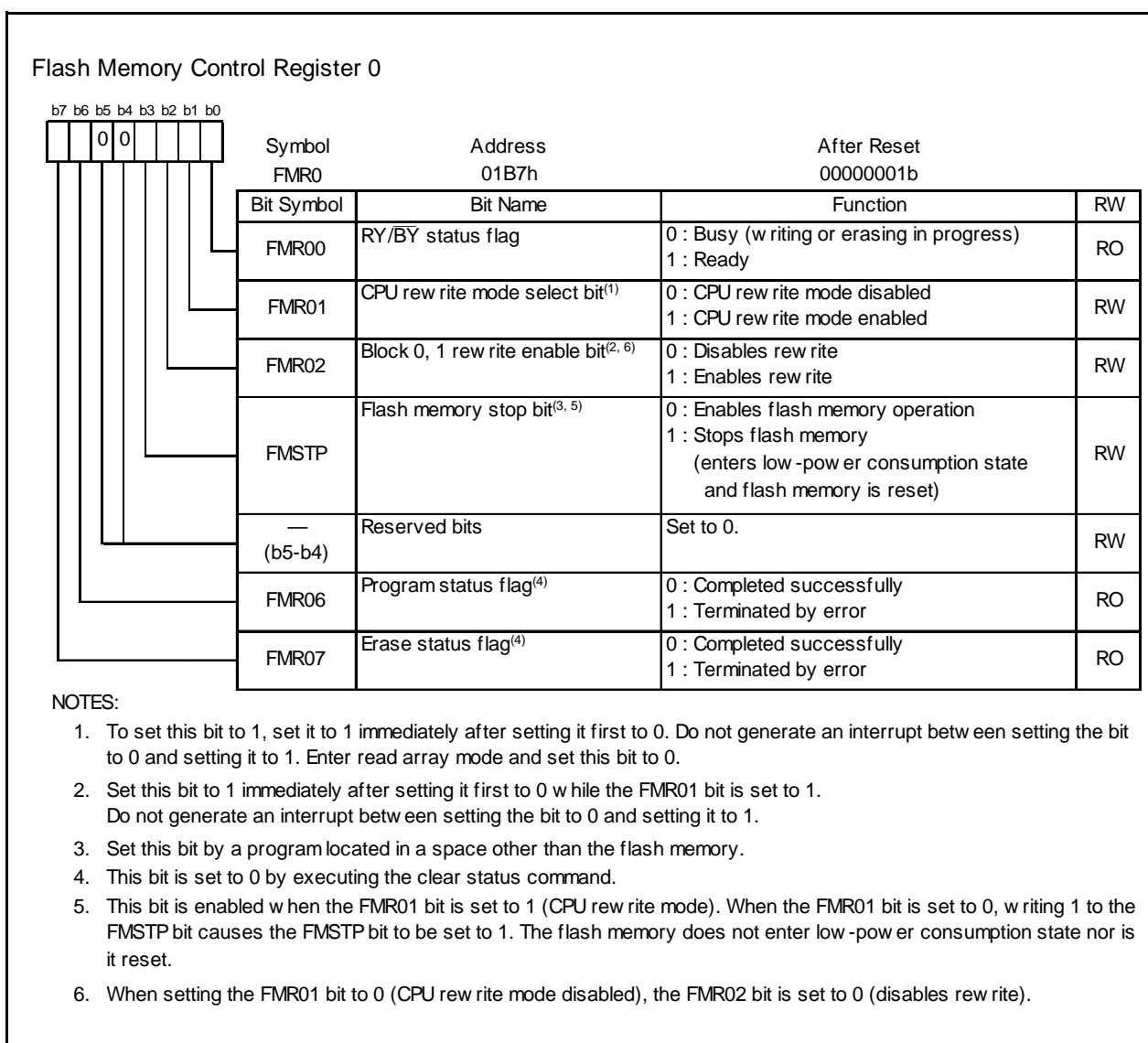

Figure 19.5 FMR0 Register

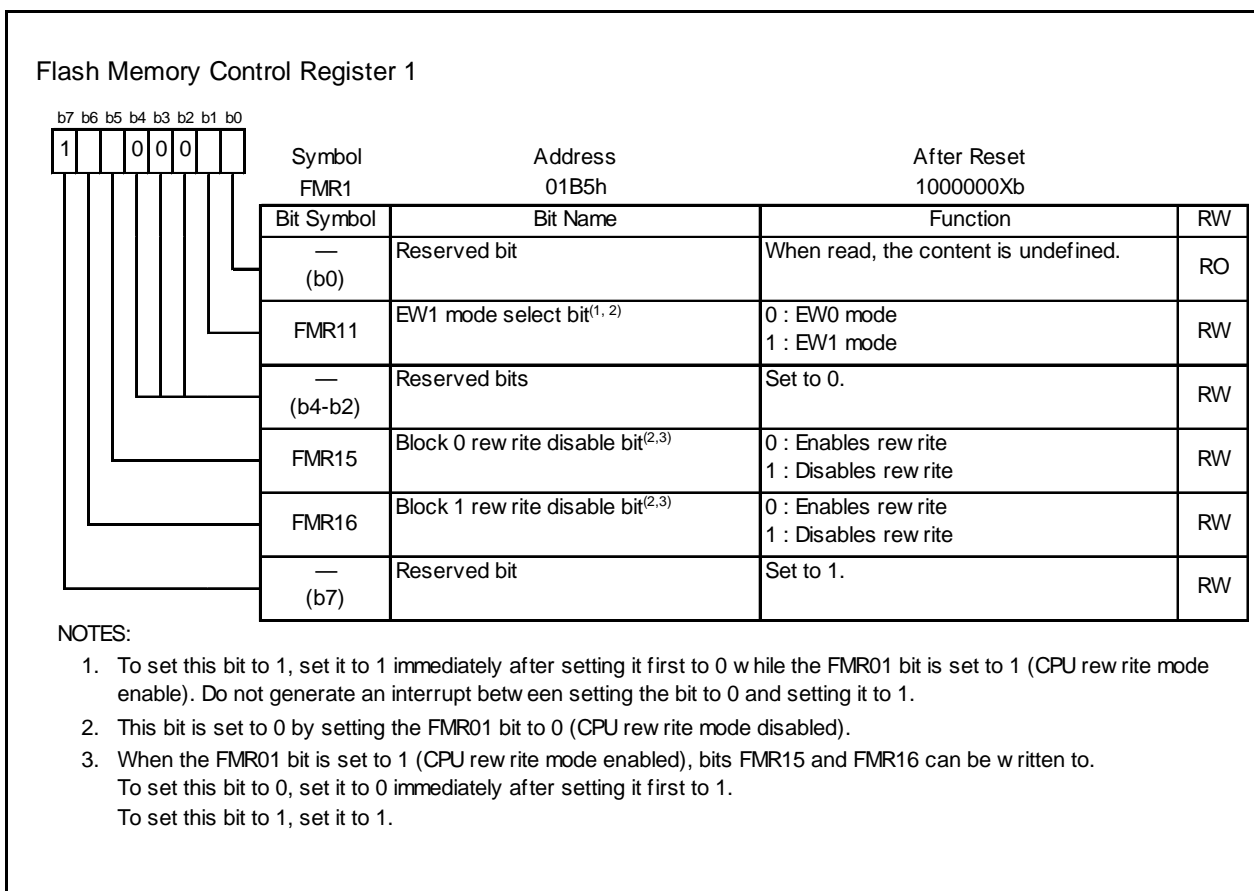

Figure 19.6 FMR1 Register

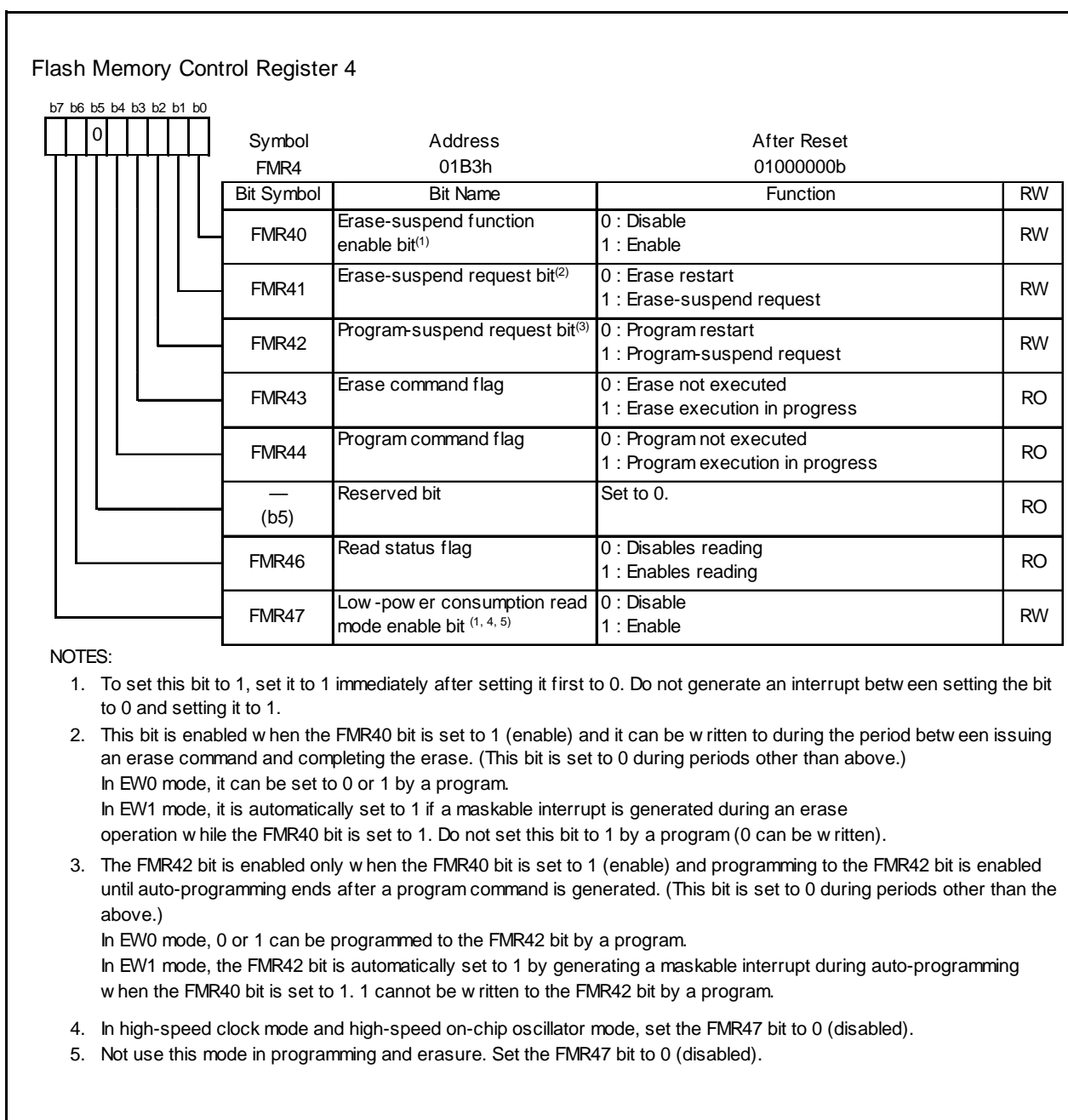

Figure 19.7 FMR4 Register

Figure 19.8 shows the Timing of Suspend Operation.

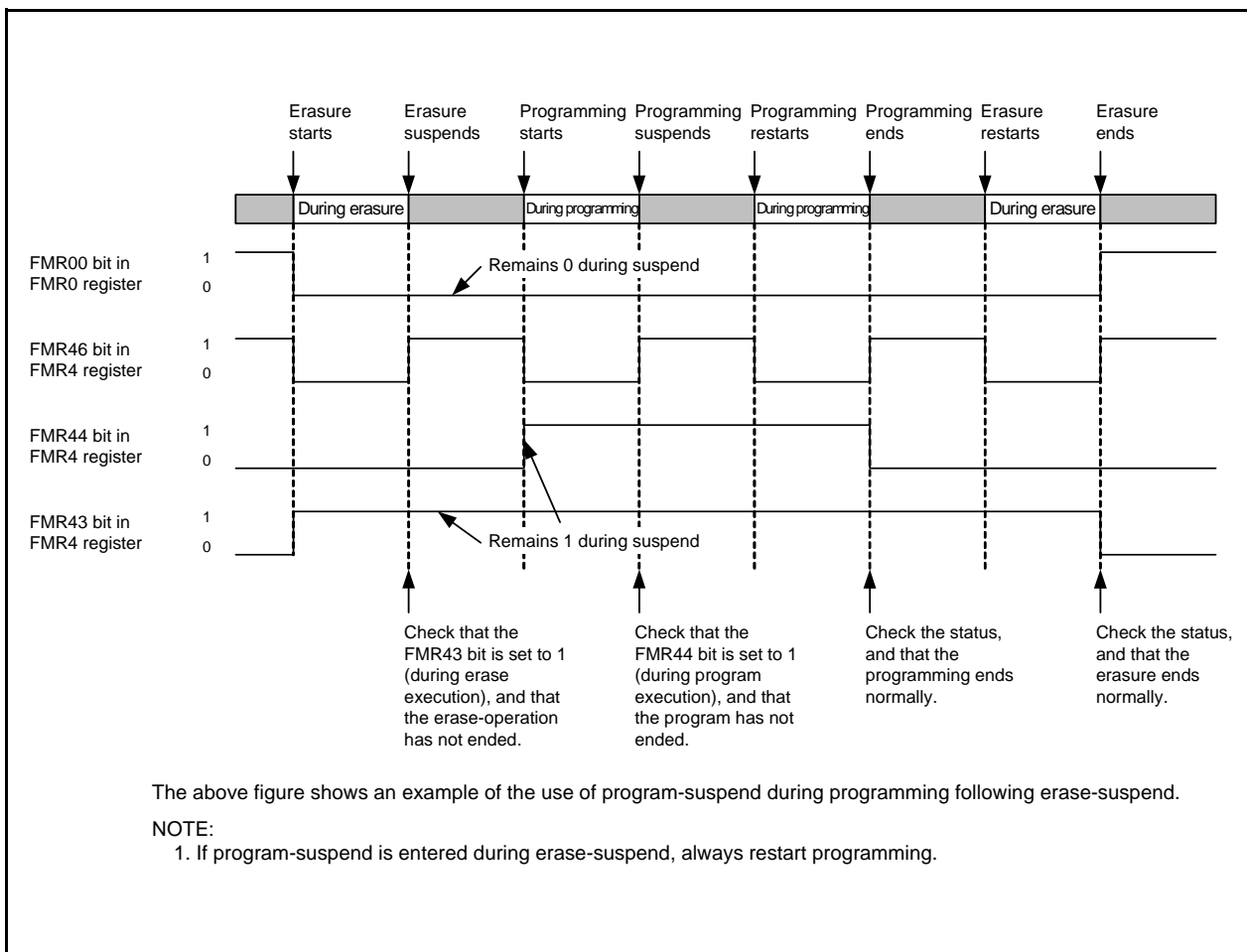

Figure 19.8 Timing of Suspend Operation

Figure 19.9 shows How to Set and Exit EW0 Mode. Figure 19.10 shows How to Set and Exit EW1 Mode.

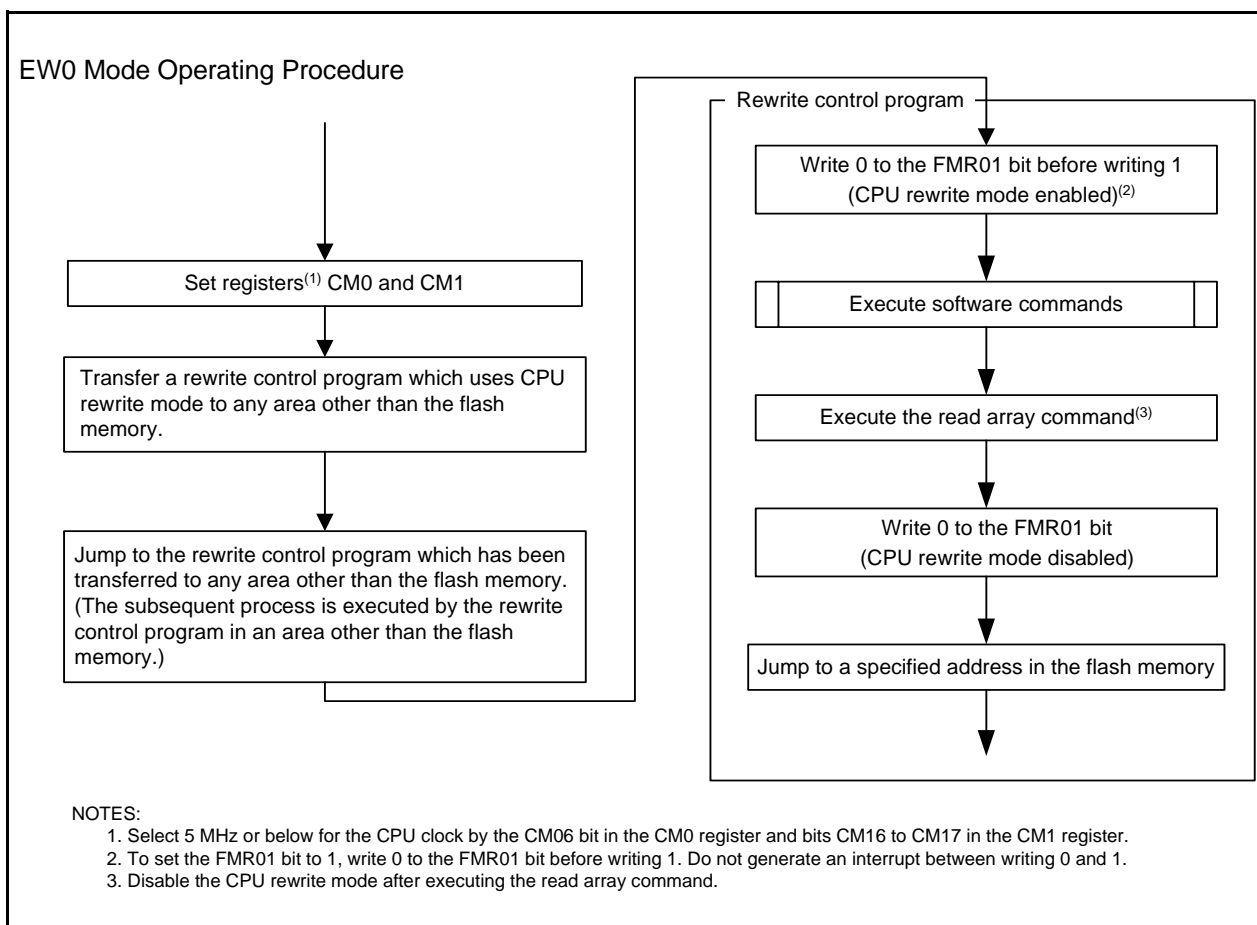

Figure 19.9 How to Set and Exit EW0 Mode

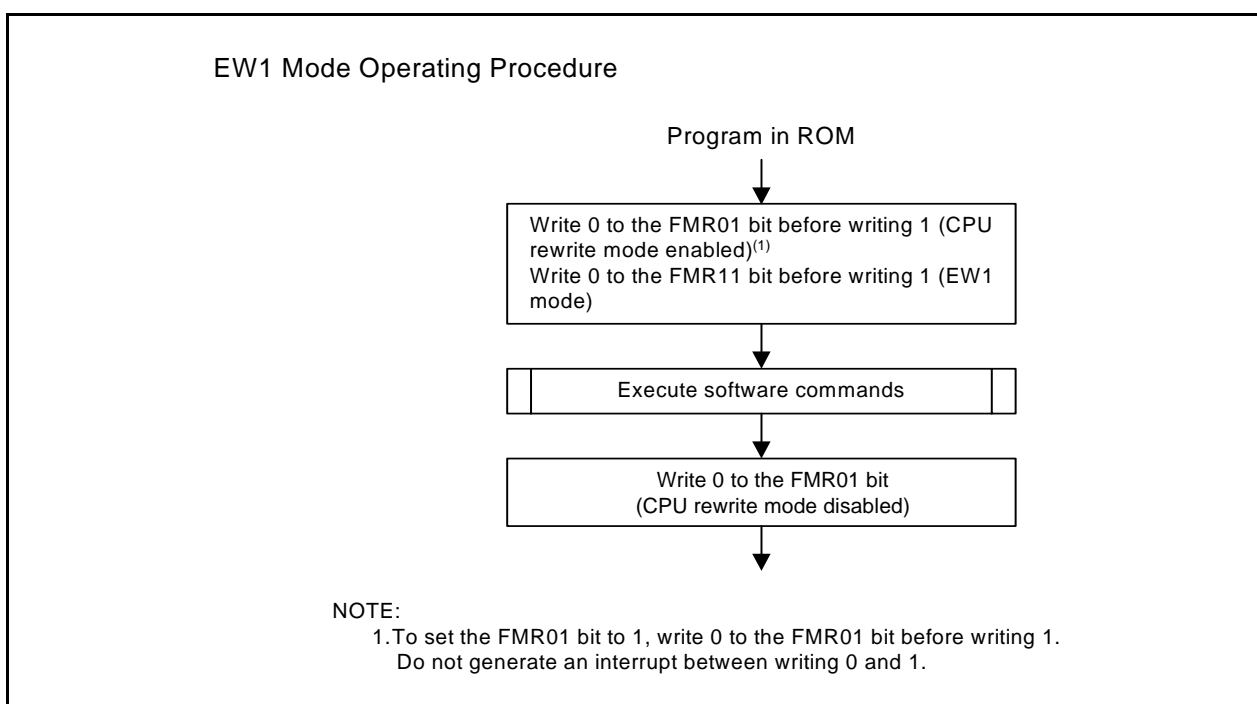

Figure 19.10 How to Set and Exit EW1 Mode

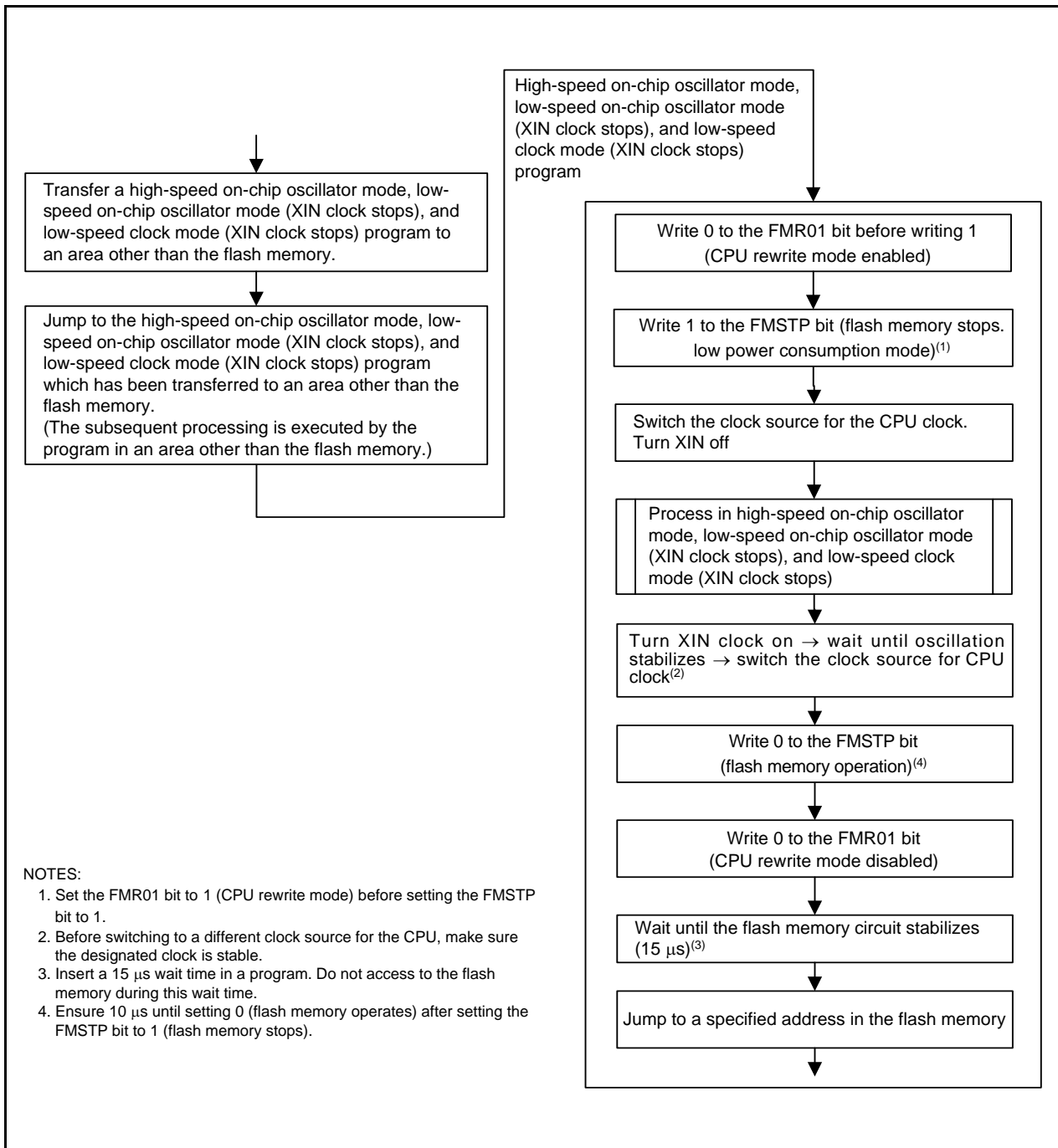

Figure 19.11 Process to Reduce Power Consumption in High-Speed On-Chip Oscillator Mode, Low-Speed On-Chip Oscillator Mode (XIN Clock Stops) and Low-Speed Clock Mode (XIN Clock Stops)

19.4.3 Software Commands

The software commands are described below. Read or write commands and data in 8-bit units.

Table 19.4 Software Commands

Command	First Bus Cycle			Second Bus Cycle		
	Mode	Address	Data (D7 to D0)	Mode	Address	Data (D7 to D0)
Read array	Write	x	FFh			
Read status register	Write	x	70h	Read	x	SRD
Clear status register	Write	x	50h			
Program	Write	WA	40h	Write	WA	WD
Block erase	Write	x	20h	Write	BA	D0h

SRD: Status register data (D7 to D0)

WA: Write address (ensure the address specified in the first bus cycle is the same address as the write address specified in the second bus cycle.)

WD: Write data (8 bits)

BA: Given block address

x: Any specified address in the user ROM area

19.4.3.1 Read Array Command

The read array command reads the flash memory.

The MCU enters read array mode when FFh is written in the first bus cycle. When the read address is entered in the following bus cycles, the content of the specified address can be read in 8-bit units.

Since the MCU remains in read array mode until another command is written, the contents of multiple addresses can be read continuously.

In addition, the MCU enters read array mode after a reset.

19.4.3.2 Read Status Register Command

The read status register command is used to read the status register.

When 70h is written in the first bus cycle, the status register can be read in the second bus cycle (refer to **19.4.4 Status Registers**). When reading the status register, specify an address in the user ROM area.

Do not execute this command in EW1 mode.

The MCU remains in read status register mode until the next read array command is written.

19.4.3.3 Clear Status Register Command

The clear status register command sets the status register to 0.

When 50h is written in the first bus cycle, bits FMR06 to FMR07 in the FMR0 register and SR4 to SR5 in the status register are set to 0.

19.4.3.4 Program Command

The program command writes data to the flash memory in 1-byte units.

By writing 40h in the first bus cycle and data to the write address in the second bus cycle, an auto-program operation (data program and verify) will start. Make sure the address value specified in the first bus cycle is the same address as the write address specified in the second bus cycle.

The FMR00 bit in the FMR0 register can be used to determine whether auto-programming has completed. When suspend function disabled, the FMR00 bit is set to 0 during auto-programming and set to 1 when auto-programming completes. When suspend function enabled, the FMR44 bit is set to 1 during auto-programming and set to 0 when auto-programming completes.

The FMR06 bit in the FMR0 register can be used to determine the result of auto-programming after it has been finished (refer to **19.4.5 Full Status Check**).

Do not write additions to the already programmed addresses.

When the FMR02 bit in the FMR0 register is set to 0 (rewriting disabled), or the FMR02 bit is set to 1 (rewrite enabled) and the FMR15 bit in the FMR1 register is set to 1 (rewriting disabled), program commands targeting block 0 are not acknowledged. When the FMR16 bit is set to 1 (rewriting disabled), program commands targeting block 1 are not acknowledged.

Figure 19.12 shows the Program Command (When Suspend Function Disabled). Figure 19.13 shows the Program Command (When Suspend Function Enabled).

In EW1 mode, do not execute this command for any address which a rewrite control program is allocated.

In EW0 mode, the MCU enters read status register mode at the same time auto-programming starts and the status register can be read. The status register bit 7 (SR7) is set to 0 at the same time auto-programming starts and set back to 1 when auto-programming completes. In this case, the MCU remains in read status register mode until the next read array command is written. The status register can be read to determine the result of auto-programming after auto-programming has completed.

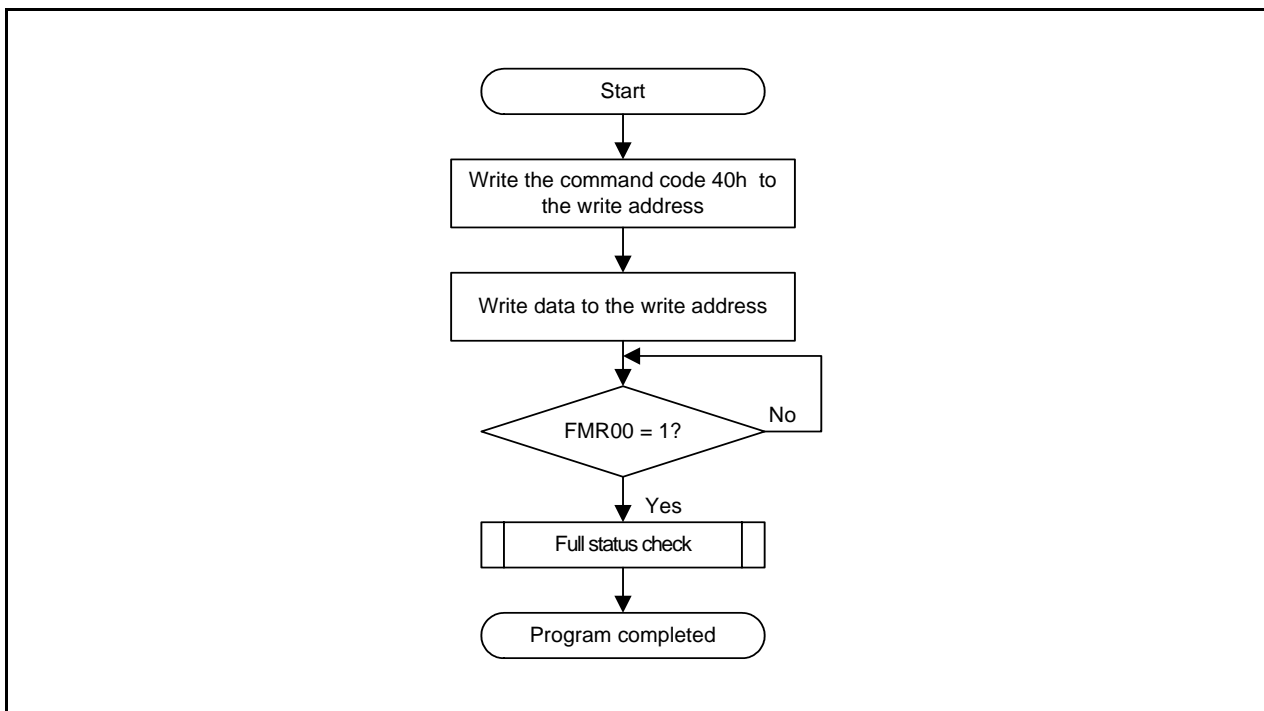

Figure 19.12 Program Command (When Suspend Function Disabled)

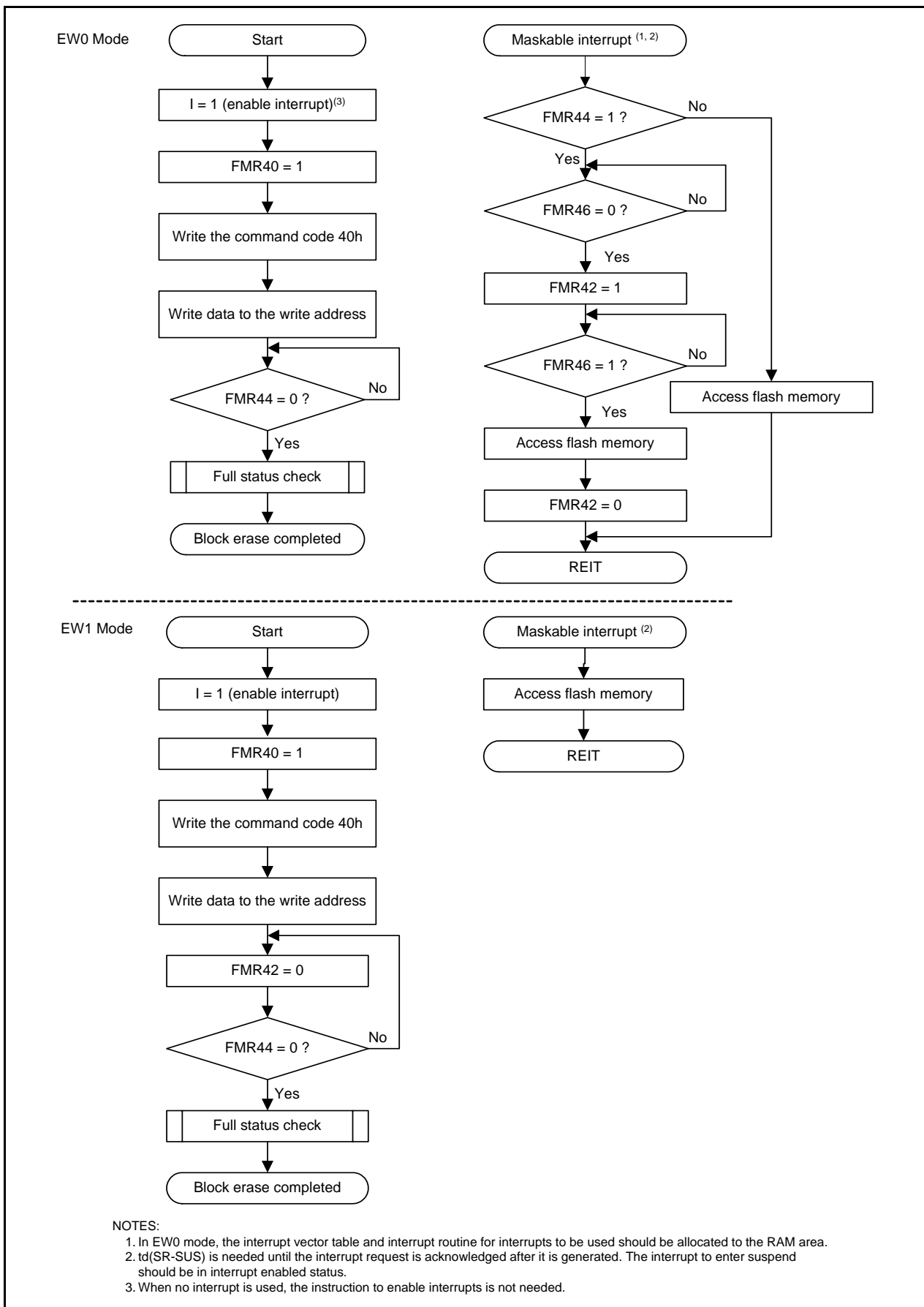

Figure 19.13 Program Command (When Suspend Function Enabled)

19.4.3.5 Block Erase

When 20h is written in the first bus cycle and D0h is written to a given address of a block in the second bus cycle, an auto-erase operation (erase and verify) of the specified block starts.

The FMR00 bit in the FMR0 register can be used to determine whether auto-erase has completed.

The FMR00 bit is set to 0 during auto-erase and set to 1 when auto-erase completes.

The FMR07 bit in the FMR0 register can be used to determine the result of auto-erase after auto-erase has completed (refer to **19.4.5 Full Status Check**).

When the FMR02 bit in the FMR0 register is set to 0 (rewriting disabled) or the FMR02 bit is set to 1 (rewriting enabled) and the FMR15 bit in the FMR1 register is set to 1 (rewriting disabled), the block erase commands targeting block 0 are not acknowledged. When the FMR16 bit is set to 1 (rewriting disabled), block erase commands targeting block 1 are not acknowledged.

Do not use the block erase command during program-suspend.

Figure 19.14 shows the Block Erase Command (When Erase-Suspend Function Disabled). Figure 19.15 shows the Block Erase Command (When Erase-Suspend Function Enabled).

In EW1 mode, do not execute this command for any address to which a rewrite control program is allocated.

In EW0 mode, the MCU enters read status register mode at the same time auto-erase starts and the status register can be read. The status register bit 7 (SR7) is set to 0 at the same time auto-erase starts and set back to 1 when auto-erase completes. In this case, the MCU remains in read status register mode until the next read array command is written.

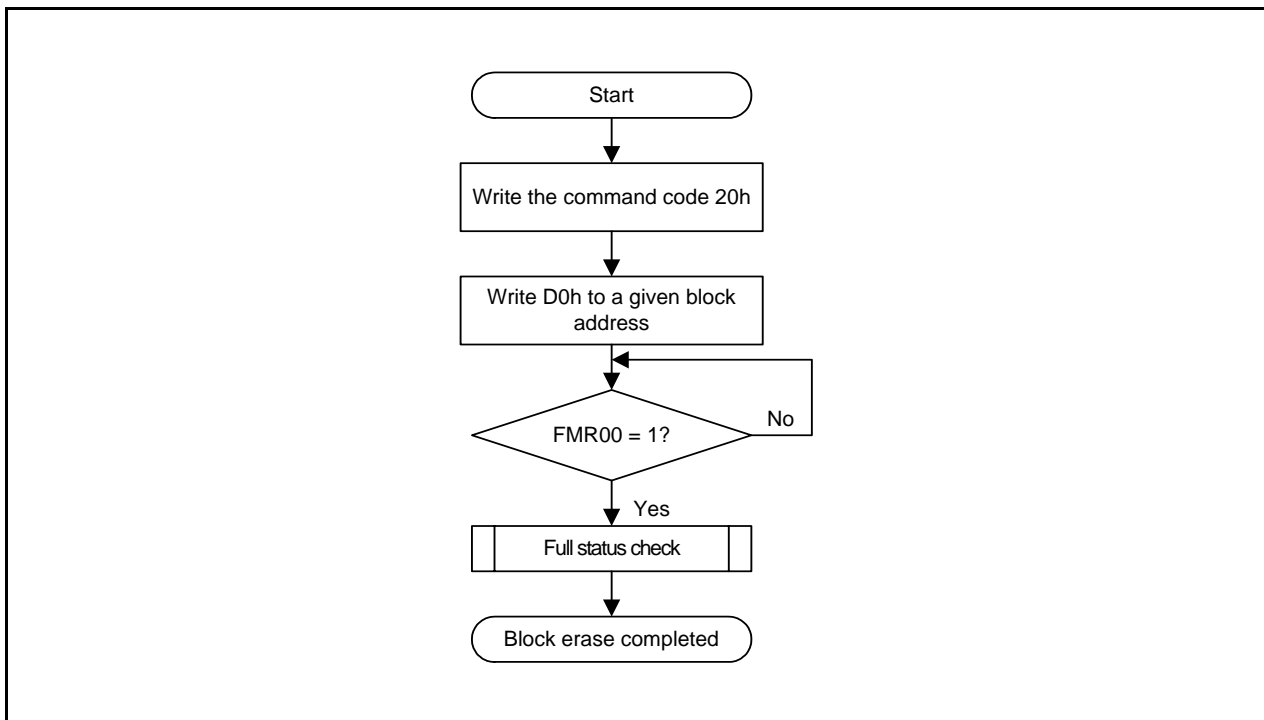

Figure 19.14 Block Erase Command (When Erase-Suspend Function Disabled)

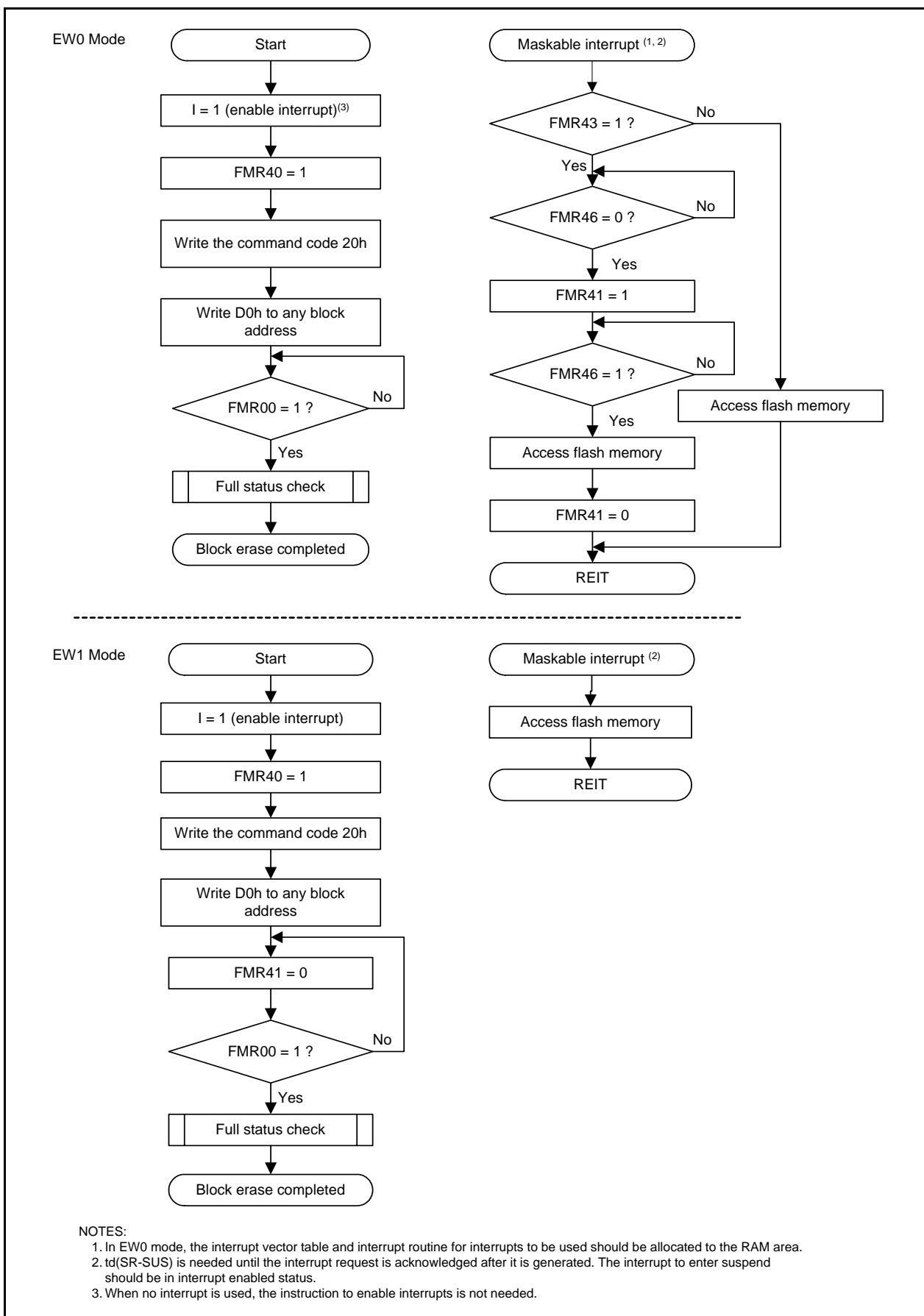

Figure 19.15 Block Erase Command (When Erase-Suspend Function Enabled)

19.4.4 Status Registers

The status register indicates the operating status of the flash memory and whether an erase or program operation has completed normally or in error. Status of the status register can be read by bits FMR00, FMR06, and FMR07 in the FMR0 register.

Table 19.5 lists the Status Register Bits.

In EW0 mode, the status register can be read in the following cases:

- When a given address in the user ROM area is read after writing the read status register command
- When a given address in the user ROM area is read after executing program or block erase command but before executing the read array command.

19.4.4.1 Sequencer Status (Bits SR7 and FMR00)

The sequencer status bits indicate the operating status of the flash memory. SR7 is set to 0 (busy) during auto-programming and auto-erasure, and is set to 1 (ready) at the same time the operation completes.

19.4.4.2 Erase Status (Bits SR5 and FMR07)

Refer to 19.4.5 Full Status Check.

19.4.4.3 Program Status (Bits SR4 and FMR06)

Refer to 19.4.5 Full Status Check.

Table 19.5 Status Register Bits

Status Register Bit	FMR0 Register Bit	Status Name	Description		Value after Reset
			0	1	
SR0 (D0)	–	Reserved	–	–	–
SR1 (D1)	–	Reserved	–	–	–
SR2 (D2)	–	Reserved	–	–	–
SR3 (D3)	–	Reserved	–	–	–
SR4 (D4)	FMR06	Program status	Completed normally	Error	0
SR5 (D5)	FMR07	Erase status	Completed normally	Error	0
SR6 (D6)	–	Reserved	–	–	–
SR7 (D7)	FMR00	Sequencer status	Busy	Ready	1

D0 to D7: Indicate the data bus which is read when the read status register command is executed.

Bits FMR07 (SR5) to FMR06 (SR4) are set to 0 by executing the clear status register command.

When the FMR07 bit (SR5) or FMR06 bit (SR4) is set to 1, the program and block erase commands cannot be accepted.

19.4.5 Full Status Check

When an error occurs, bits FMR06 to FMR07 in the FMR0 register are set to 1, indicating the occurrence of an error. Therefore, checking these status bits (full status check) can be used to determine the execution result.

Table 19.6 lists the Errors and FMR0 Register Status. Figure 19.16 shows the Full Status Check and Handling Procedure for Individual Errors.

Table 19.6 Errors and FMR0 Register Status

FRM00 Register (Status Register) Status		Error	Error Occurrence Condition
FMR07(SR5)	FMR06(SR4)		
1	1	Command sequence error	<ul style="list-style-type: none"> • When a command is not written correctly • When invalid data other than that which can be written in the second bus cycle of the block erase command is written (i.e., other than D0h or FFh)⁽¹⁾ • When the program command or block erase command is executed while rewriting is disabled by the FMR02 bit in the FMR0 register, or the FMR15 or FMR16 bit in the FMR1 register. • When an address not allocated in flash memory is input during erase command input • When attempting to erase the block for which rewriting is disabled during erase command input. • When an address not allocated in flash memory is input during write command input. • When attempting to write to a block for which rewriting is disabled during write command input.
1	0	Erase error	<ul style="list-style-type: none"> • When the block erase command is executed but auto-erasure does not complete correctly
0	1	Program error	<ul style="list-style-type: none"> • When the program command is executed but not auto-programming does not complete.

NOTE:

1. The MCU enters read array mode when FFh is written in the second bus cycle of these commands. At the same time, the command code written in the first bus cycle is disabled.

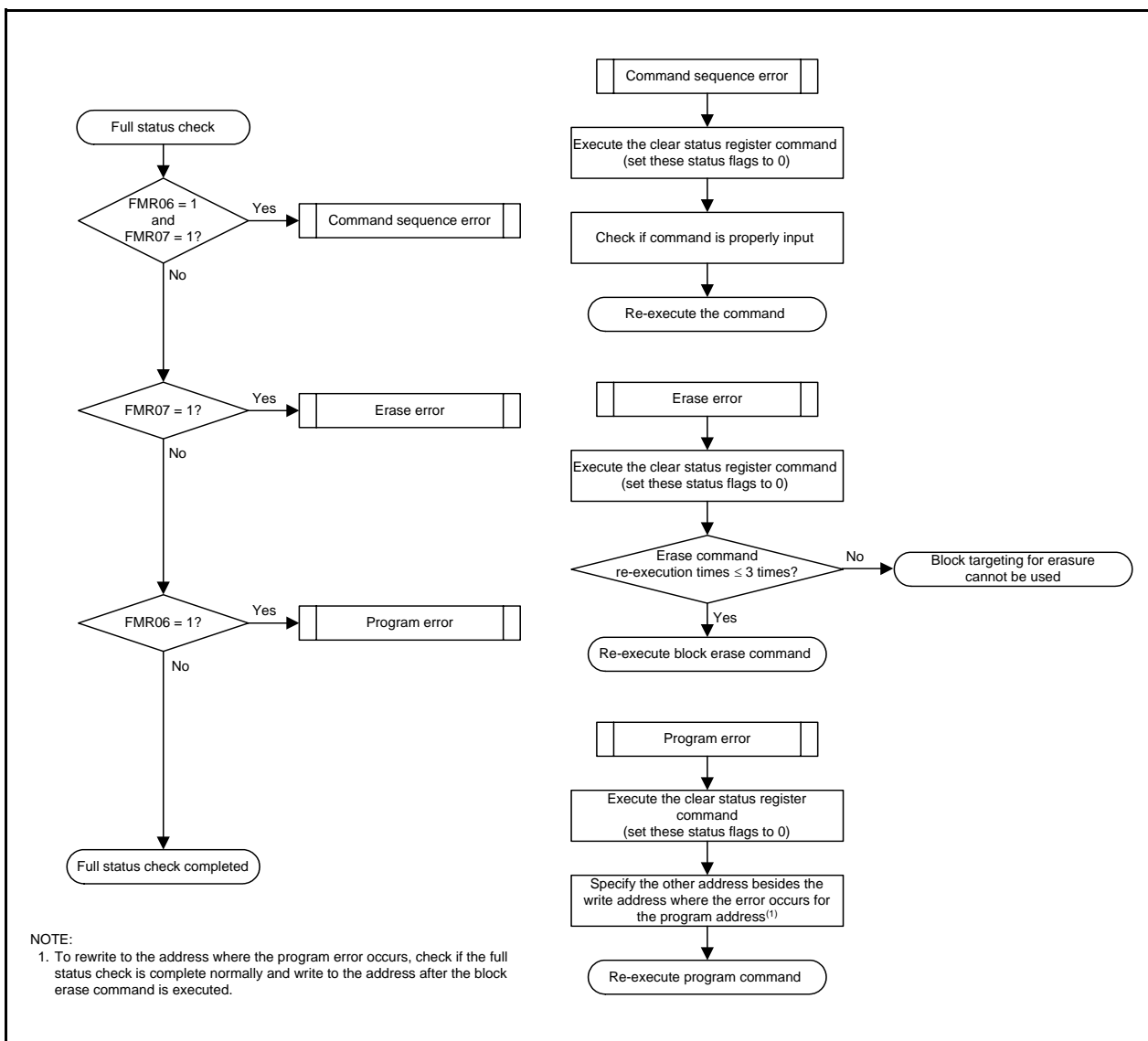

Figure 19.16 Full Status Check and Handling Procedure for Individual Errors

19.5 Standard Serial I/O Mode

In standard serial I/O mode, the user ROM area can be rewritten while the MCU is mounted on-board by using a serial programmer which is suitable for the MCU.

There are three types of Standard serial I/O modes:

- Standard serial I/O mode 1Clock synchronous serial I/O used to connect with a serial programmer
- Standard serial I/O mode 2Clock asynchronous serial I/O used to connect with a serial programmer
- Standard serial I/O mode 3Special clock asynchronous serial I/O used to connect with a serial programmer

This MCU uses Standard serial I/O mode 2 and Standard serial I/O mode 3.

Refer to **Appendix 2. Connection Examples between Serial Writer and On-Chip Debugging Emulator.** Contact the manufacturer of your serial programmer for details. Refer to the user's manual of your serial programmer for instructions on how to use it.

Table 19.7 lists the Pin Functions (Flash Memory Standard Serial I/O Mode 2), Table 19.8 lists the Pin Functions (Flash Memory Standard Serial I/O Mode 3), and Figure 19.17 shows Pin Connections for Standard Serial I/O Mode 3.

After processing the pins shown in Table 19.8 and rewriting the flash memory using the programmer, apply "H" to the MODE pin and reset the hardware to run a program in the flash memory in single-chip mode.

19.5.1 ID Code Check Function

The ID code check function determines whether the ID codes sent from the serial programmer and those written in the flash memory match (refer to **19.3 Functions to Prevent Rewriting of Flash Memory**).

Table 19.7 Pin Functions (Flash Memory Standard Serial I/O Mode 2)

Pin	Name	I/O	Description
VCC,VSS	Power input		Apply the voltage guaranteed for programming and erasure to the VCC pin and 0 V to the VSS pin.
RESET	Reset input	I	Reset input pin.
P4_6/XIN	P4_6 input/clock input	I	Connect a ceramic resonator or crystal oscillator between the XIN and XOUT pins.
P4_7/XOUT	P4_7 input/clock output	I/O	
P4_3/XCIN	P4_3 input/clock input	I	Connect crystal oscillator between pins XCIN and XCOUT.
P4_4/XCOUT	P4_4 input/clock output	I/O	
P0_0 to P0_7	Input port P0	I	Input "H" or "L" level signal or leave the pin open.
P1_0 to P1_7	Input port P1	I	Input "H" or "L" level signal or leave the pin open.
P2_0 to P2_7	Input port P2	I	Input "H" or "L" level signal or leave the pin open.
P3_0, P3_1, P3_3 to P3_5, P3_7	Input port P3	I	Input "H" or "L" level signal or leave the pin open.
P4_2/VREF, P4_5	Input port P4	I	Input "H" or "L" level signal or leave the pin open.
P6_0 to P6_5	Input port P6	I	Input "H" or "L" level signal or leave the pin open.
MODE	MODE	I/O	Serial data I/O pin. Connect to the flash programmer.
P6_6	TXD output	O	Serial data output pin.
P6_7	RXD input	I	Serial data input pin.

Table 19.8 Pin Functions (Flash Memory Standard Serial I/O Mode 3)

Pin	Name	I/O	Description
VCC,VSS	Power input		Apply the voltage guaranteed for programming and erasure to the VCC pin and 0 V to the VSS pin.
RESET	Reset input	I	Reset input pin.
P4_6/XIN	P4_6 input/clock input	I	Connect a ceramic resonator or crystal oscillator between the XIN and XOUT pins when connecting external oscillator. Apply "H" and "L" or leave the pin open when using as input port.
P4_7/XOUT	P4_7 input/clock output	I/O	
P4_3/XCIN	P4_3 input/clock input	I	Connect crystal oscillator between pins XCIN and XCOU when connecting external oscillator. Apply "H" and "L" or leave the pin open when using as a port.
P4_4/XCOU	P4_4 input/clock output	I/O	
P0_0 to P0_7	Input port P0	I	Input "H" or "L" level signal or leave the pin open.
P1_0 to P1_7	Input port P1	I	Input "H" or "L" level signal or leave the pin open.
P2_0 to P2_7	Input port P2	I	Input "H" or "L" level signal or leave the pin open.
P3_0, P3_1, P3_3 to P3_5, P3_7	Input port P3	I	Input "H" or "L" level signal or leave the pin open.
P4_2/VREF, P4_5	Input port P4	I	Input "H" or "L" level signal or leave the pin open.
P6_0 to P6_7	Input port P6	I	Input "H" or "L" level signal or leave the pin open.
MODE	MODE	I/O	Serial data I/O pin. Connect to the flash programmer.

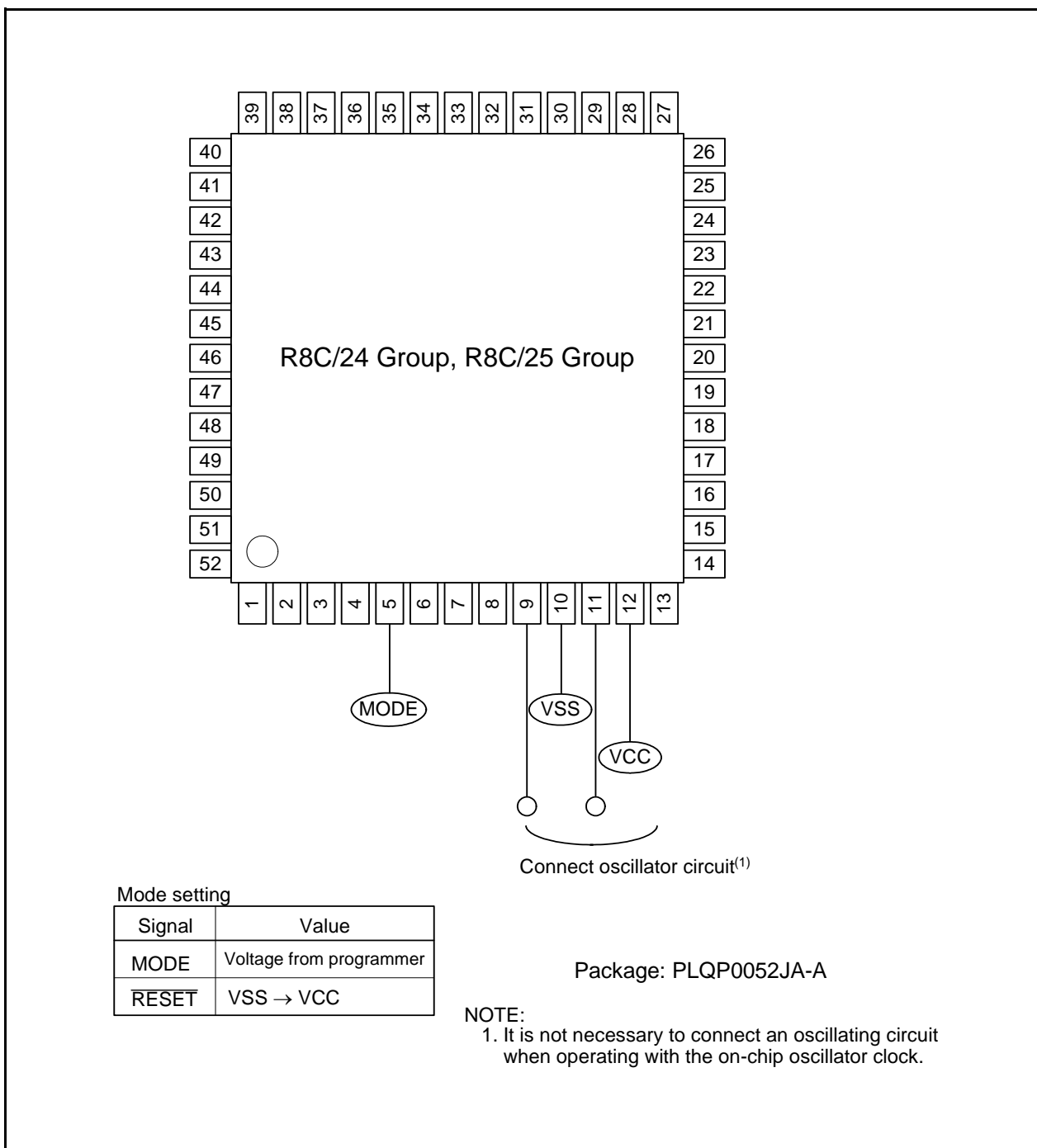

Figure 19.17 Pin Connections for Standard Serial I/O Mode 3

19.5.1.1 Example of Circuit Application in Standard Serial I/O Mode

Figure 19.18 shows an example of Pin Processing in Standard Serial I/O Mode 2 and Figure 19.19 shows an example of Pin Processing in Standard Serial I/O Mode 3. Since the controlled pins vary depending on the programmer, refer to the manual of your serial programmer for details.

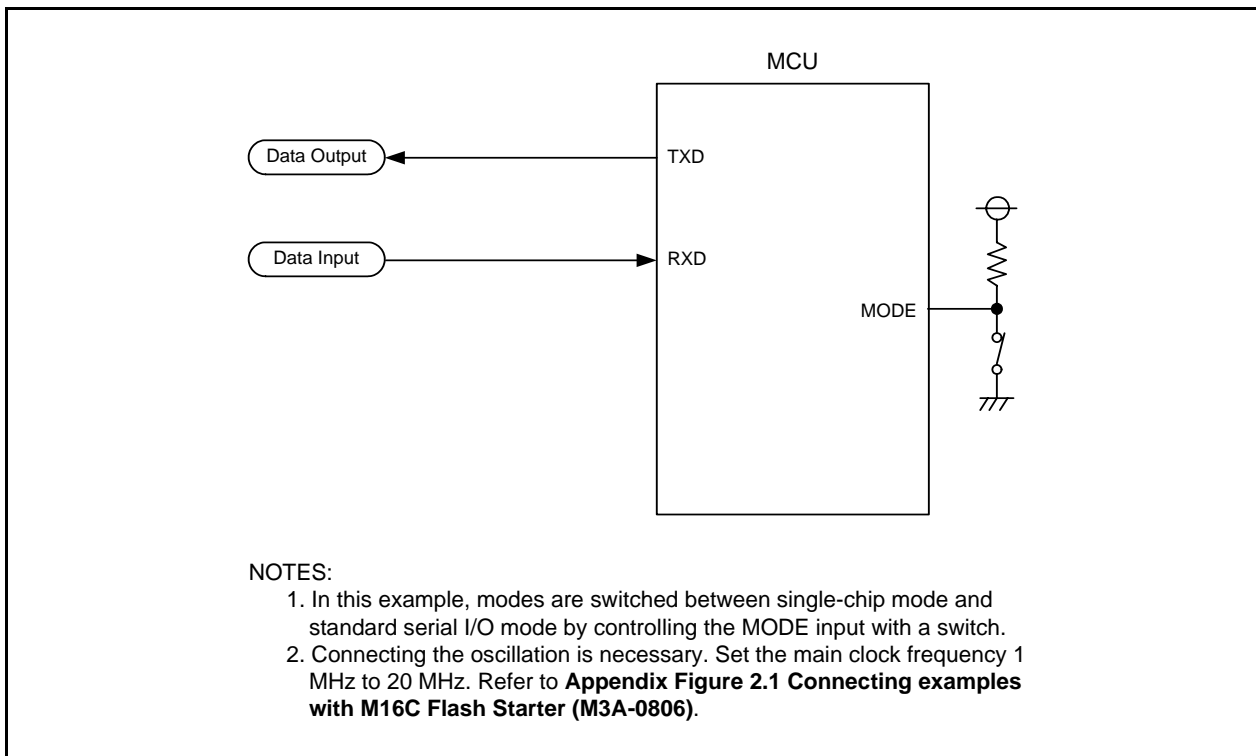

Figure 19.18 Pin Processing in Standard Serial I/O Mode 2

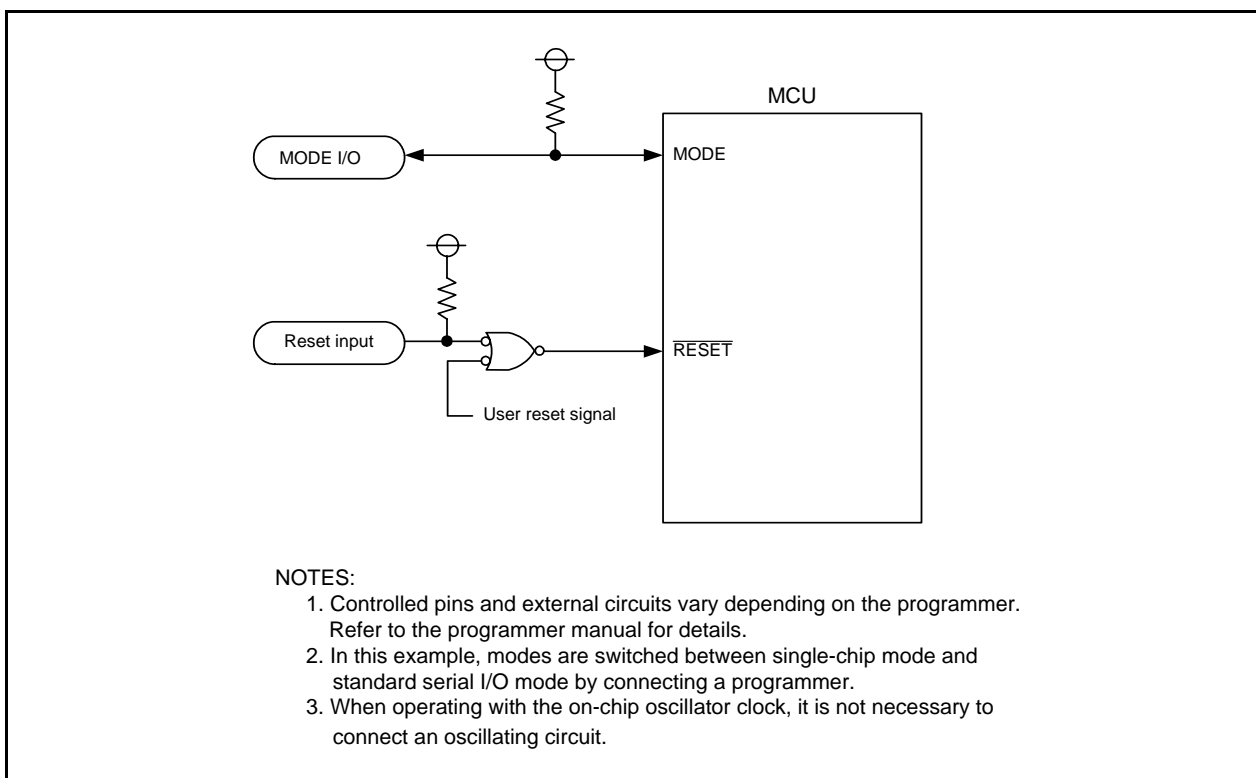

Figure 19.19 Pin Processing in Standard Serial I/O Mode 3

19.6 Parallel I/O Mode

Parallel I/O mode is used to input and output software commands, addresses and data necessary to control (read, program, and erase) the on-chip flash memory. Use a parallel programmer which supports this MCU. Contact the manufacturer of the parallel programmer for more information, and refer to the user's manual of the parallel programmer for details on how to use it.

ROM areas shown in Figures 19.1 and 19.2 can be rewritten in parallel I/O mode.

19.6.1 ROM Code Protect Function

The ROM code protect function disables the reading and rewriting of the flash memory. (Refer to the **19.3 Functions to Prevent Rewriting of Flash Memory.**)

19.7 Notes on Flash Memory

19.7.1 CPU Rewrite Mode

19.7.1.1 Operating Speed

Before entering CPU rewrite mode (EW0 mode), select 5 MHz or below for the CPU clock using the CM06 bit in the CM0 register and bits CM16 to CM17 in the CM1 register. This does not apply to EW1 mode.

19.7.1.2 Prohibited Instructions

The following instructions cannot be used in EW0 mode because they reference data in the flash memory: UND, INTO, and BRK.

19.7.1.3 Interrupts

Table 19.9 lists the EW0 Mode Interrupts and Table 19.10 lists the EW1 Mode Interrupts.

Table 19.9 EW0 Mode Interrupts

Mode	Status	When Maskable Interrupt Request is Acknowledged	When Watchdog Timer, Oscillation Stop Detection, Voltage Monitor 1, or Voltage Monitor 2 Interrupt Request is Acknowledged
EW0	During auto-erasure	Any interrupt can be used by allocating a vector in RAM	Once an interrupt request is acknowledged, auto-programming or auto-erasure is forcibly stopped immediately and the flash memory is reset. Interrupt handling starts after the fixed period and the flash memory restarts. Since the block during auto-erasure or the address during auto-programming is forcibly stopped, the normal value may not be read. Execute auto-erasure again and ensure it completes normally. Since the watchdog timer does not stop during the command operation, interrupt requests may be generated. Reset the watchdog timer regularly.
	Auto-programming		

NOTES:

1. Do not use the address match interrupt while a command is being executed because the vector of the address match interrupt is allocated in ROM.
2. Do not use a non-maskable interrupt while block 0 is being automatically erased because the fixed vector is allocated in block 0.

Table 19.10 EW1 Mode Interrupts

Mode	Status	When Maskable Interrupt Request is Acknowledged	When Watchdog Timer, Oscillation Stop Detection, Voltage Monitor 1, or Voltage Monitor 2 Interrupt Request is Acknowledged
EW1	During auto-erasure (erase-suspend function enabled)	Auto-erasure is suspended after $t_d(SR-SUS)$ and interrupt handling is executed. Auto-erasure can be restarted by setting the FMR41 bit in the FMR4 register to 0 (erase restart) after interrupt handling completes.	Once an interrupt request is acknowledged, auto-programming or auto-erasure is forcibly stopped immediately and the flash memory is reset. Interrupt handling starts after the fixed period and the flash memory restarts. Since the block during auto-erasure or the address during auto-programming is forcibly stopped, the normal value may not be read. Execute auto-erasure again and ensure it completes normally. Since the watchdog timer does not stop during the command operation, interrupt requests may be generated. Reset the watchdog timer regularly using the erase-suspend function.
	During auto-erasure (erase-suspend function disabled)	Auto-erasure has priority and the interrupt request acknowledgement is put on standby. Interrupt handling is executed after auto-erasure completes.	
	During auto-programming (program suspend function enabled)	Auto-programming is suspended after $t_d(SR-SUS)$ and interrupt handling is executed. Auto-programming can be restarted by setting the FMR42 bit in the FMR4 register to 0 (program restart) after interrupt handling completes.	
	During auto-programming (program suspend function disabled)	Auto-programming has priority and the interrupt request acknowledgement is put on standby. Interrupt handling is executed after auto-programming completes.	

NOTES:

1. Do not use the address match interrupt while a command is executing because the vector of the address match interrupt is allocated in ROM.
2. Do not use a non-maskable interrupt while block 0 is being automatically erased because the fixed vector is allocated in block 0.

19.7.1.4 How to Access

Write 0 before writing 1 when setting the FMR01, FMR02, or FMR11 bit to 1. Do not generate an interrupt between writing 0 and 1.

19.7.1.5 Rewriting User ROM Area

In EW0 Mode, if the supply voltage drops while rewriting any block in which a rewrite control program is stored, it may not be possible to rewrite the flash memory because the rewrite control program cannot be rewritten correctly. In this case, use standard serial I/O mode.

19.7.1.6 Program

Do not write additions to the already programmed address.

19.7.1.7 Entering Stop Mode or Wait Mode

Do not enter stop mode or wait mode during erase-suspend.

19.7.1.8 Program and Erase Voltage for Flash Memory

To perform programming and erasure, use $V_{CC} = 2.7\text{ V}$ to 5.5 V as the supply voltage. Do not perform programming and erasure at less than 2.7 V .

20. Electrical Characteristics

The electrical characteristics of N version ($T_{opr} = -20^{\circ}\text{C}$ to 85°C) and D version ($T_{opr} = -40^{\circ}\text{C}$ to 85°C) are listed below.

Please contact Renesas Technology sales offices for the electrical characteristics in the Y version ($T_{opr} = -20^{\circ}\text{C}$ to 105°C).

Table 20.1 Absolute Maximum Ratings

Symbol	Parameter	Condition	Rated Value	Unit
V_{cc}/AV_{cc}	Supply voltage		-0.3 to 6.5	V
V_i	Input voltage		-0.3 to $V_{cc} + 0.3$	V
V_o	Output voltage		-0.3 to $V_{cc} + 0.3$	V
P_d	Power dissipation	$T_{opr} = 25^{\circ}\text{C}$	500 ⁽¹⁾	mW
T_{opr}	Operating ambient temperature		-20 to 85 (N version) / -40 to 85 (D version)	$^{\circ}\text{C}$
T_{stg}	Storage temperature		-65 to 150	$^{\circ}\text{C}$

NOTE:

1. 300 mW for the PTLG0064JA-A package.

Table 20.2 Recommended Operating Conditions

Symbol	Parameter		Conditions	Standard			Unit
				Min.	Typ.	Max.	
V _{CC} /AV _{CC}	Supply voltage			2.2	–	5.5	V
V _{SS} /AV _{SS}	Supply voltage			–	0	–	V
V _{IH}	Input “H” voltage			0.8 V _{CC}	–	V _{CC}	V
V _{IL}	Input “L” voltage			0	–	0.2 V _{CC}	V
I _{OH} (sum)	Peak sum output “H” current	Sum of all pins I _{OH} (peak)		–	–	-160	mA
I _{OH} (sum)	Average sum output “H” current	Sum of all pins I _{OH} (avg)		–	–	-80	mA
I _{OH} (peak)	Peak output “H” current	Except P2_0 to P2_7		–	–	-10	mA
		P2_0 to P2_7		–	–	-40	mA
I _{OH} (avg)	Average output “H” current	Except P2_0 to P2_7		–	–	-5	mA
		P2_0 to P2_7		–	–	-20	mA
I _{OL} (sum)	Peak sum output “L” current	Sum of all pins I _{OL} (peak)		–	–	160	mA
I _{OL} (sum)	Average sum output “L” current	Sum of all pins I _{OL} (avg)		–	–	80	mA
I _{OL} (peak)	Peak output “L” current	Except P2_0 to P2_7		–	–	10	mA
		P2_0 to P2_7		–	–	40	mA
I _{OL} (avg)	Average output “L” current	Except P2_0 to P2_7		–	–	5	mA
		P2_0 to P2_7		–	–	20	mA
f(XIN)	XIN clock input oscillation frequency		3.0 V ≤ V _{CC} ≤ 5.5 V	0	–	20	MHz
			2.7 V ≤ V _{CC} < 3.0 V	0	–	10	MHz
			2.2 V ≤ V _{CC} < 2.7 V	0	–	5	MHz
f(XCIN)	XCIN clock input oscillation frequency		2.2 V ≤ V _{CC} ≤ 5.5 V	0	–	70	kHz
–	System clock	OCD2 = 0 XIN clock selected	3.0 V ≤ V _{CC} ≤ 5.5 V	0	–	20	MHz
			2.7 V ≤ V _{CC} < 3.0 V	0	–	10	MHz
			2.2 V ≤ V _{CC} < 2.7 V	0	–	5	MHz
	On-chip oscillator clock selected	OCD2 = 1	FRA01 = 0 Low-speed on-chip oscillator clock selected	–	125	–	kHz
			FRA01 = 1 High-speed on-chip oscillator clock selected 3.0 V ≤ V _{CC} ≤ 5.5 V	–	–	20	MHz
			FRA01 = 1 High-speed on-chip oscillator clock selected 2.7 V ≤ V _{CC} ≤ 5.5 V	–	–	10	MHz
			FRA01 = 1 High-speed on-chip oscillator clock selected 2.2 V ≤ V _{CC} ≤ 5.5 V	–	–	5	MHz

NOTES:

1. V_{CC} = 2.2 to 5.5 V at T_{opr} = -20 to 85°C (N version) / -40 to 85°C (D version), unless otherwise specified.
2. The typical values when average output current is 100 ms.

Table 20.3 A/D Converter Characteristics

Symbol	Parameter		Conditions	Standard			Unit
				Min.	Typ.	Max.	
–	Resolution		$V_{ref} = AV_{CC}$	–	–	10	Bit
–	Absolute accuracy	10-bit mode	$\phi_{AD} = 10 \text{ MHz}, V_{ref} = AV_{CC} = 5.0 \text{ V}$	–	–	± 3	LSB
		8-bit mode	$\phi_{AD} = 10 \text{ MHz}, V_{ref} = AV_{CC} = 5.0 \text{ V}$	–	–	± 2	LSB
		10-bit mode	$\phi_{AD} = 10 \text{ MHz}, V_{ref} = AV_{CC} = 3.3 \text{ V}$	–	–	± 5	LSB
		8-bit mode	$\phi_{AD} = 10 \text{ MHz}, V_{ref} = AV_{CC} = 3.3 \text{ V}$	–	–	± 2	LSB
		10-bit mode	$\phi_{AD} = 5 \text{ MHz}, V_{ref} = AV_{CC} = 2.2 \text{ V}$	–	–	± 5	LSB
		8-bit mode	$\phi_{AD} = 5 \text{ MHz}, V_{ref} = AV_{CC} = 2.2 \text{ V}$	–	–	± 2	LSB
R_{ladder}	Resistor ladder		$V_{ref} = AV_{CC}$	10	–	40	$k\Omega$
t_{conv}	Conversion time	10-bit mode	$\phi_{AD} = 10 \text{ MHz}, V_{ref} = AV_{CC} = 5.0 \text{ V}$	3.3	–	–	μs
		8-bit mode	$\phi_{AD} = 10 \text{ MHz}, V_{ref} = AV_{CC} = 5.0 \text{ V}$	2.8	–	–	μs
V_{ref}	Reference voltage			2.2	–	AV_{CC}	V
V_{IA}	Analog input voltage ⁽²⁾			0	–	AV_{CC}	V
–	A/D operating clock frequency	Without sample and hold	$V_{ref} = AV_{CC} = 2.7 \text{ to } 5.5 \text{ V}$	0.25	–	10	MHz
		With sample and hold	$V_{ref} = AV_{CC} = 2.7 \text{ to } 5.5 \text{ V}$	1	–	10	MHz
		Without sample and hold	$V_{ref} = AV_{CC} = 2.2 \text{ to } 5.5 \text{ V}$	0.25	–	5	MHz
		With sample and hold	$V_{ref} = AV_{CC} = 2.2 \text{ to } 5.5 \text{ V}$	1	–	5	MHz

NOTES:

1. $AV_{CC} = 2.2 \text{ to } 5.5 \text{ V}$ at $T_{opr} = -20 \text{ to } 85^\circ\text{C}$ (N version) / $-40 \text{ to } 85^\circ\text{C}$ (D version), unless otherwise specified.
2. When the analog input voltage is over the reference voltage, the A/D conversion result will be 3FFh in 10-bit mode and FFh in 8-bit mode.

**Figure 20.1 Ports P0 to P4, P6 Timing Measurement Circuit**

Table 20.4 Flash Memory (Program ROM) Electrical Characteristics

Symbol	Parameter	Conditions	Standard			Unit
			Min.	Typ.	Max.	
–	Program/erase endurance ⁽²⁾	R8C/24 Group	100 ⁽³⁾	–	–	times
		R8C/25 Group	1,000 ⁽³⁾	–	–	times
–	Byte program time		–	50	400	μs
–	Block erase time		–	0.4	9	s
t _d (SR-SUS)	Time delay from suspend request until suspend		–	–	97+CPU clock × 6 cycles	μs
–	Interval from erase start/restart until following suspend request		650	–	–	μs
–	Interval from program start/restart until following suspend request		0	–	–	ns
–	Time from suspend until program/erase restart		–	–	3+CPU clock × 4 cycles	μs
–	Program, erase voltage		2.7	–	5.5	V
–	Read voltage		2.2	–	5.5	V
–	Program, erase temperature		0	–	60	°C
–	Data hold time ⁽⁷⁾	Ambient temperature = 55°C	20	–	–	year

NOTES:

- V_{CC} = 2.7 to 5.5 V at T_{opr} = 0 to 60°C, unless otherwise specified.
- Definition of programming/erasure endurance
The programming and erasure endurance is defined on a per-block basis.
If the programming and erasure endurance is n (n = 100 or 10,000), each block can be erased n times. For example, if 1,024 1-byte writes are performed to block A, a 1 Kbyte block, and then the block is erased, the programming/erasure endurance still stands at one.
However, the same address must not be programmed more than once per erase operation (overwriting prohibited).
- Endurance to guarantee all electrical characteristics after program and erase. (1 to Min. value can be guaranteed).
- In a system that executes multiple programming operations, the actual erasure count can be reduced by writing to sequential addresses in turn so that as much of the block as possible is used up before performing an erase operation. For example, when programming groups of 16 bytes, the effective number of rewrites can be minimized by programming up to 128 groups before erasing them all in one operation. It is also advisable to retain data on the erase count of each block and limit the number of erase operations to a certain number.
- If an error occurs during block erase, attempt to execute the clear status register command, then execute the block erase command at least three times until the erase error does not occur.
- Customers desiring program/erase failure rate information should contact their Renesas technical support representative.
- The data hold time includes time that the power supply is off or the clock is not supplied.

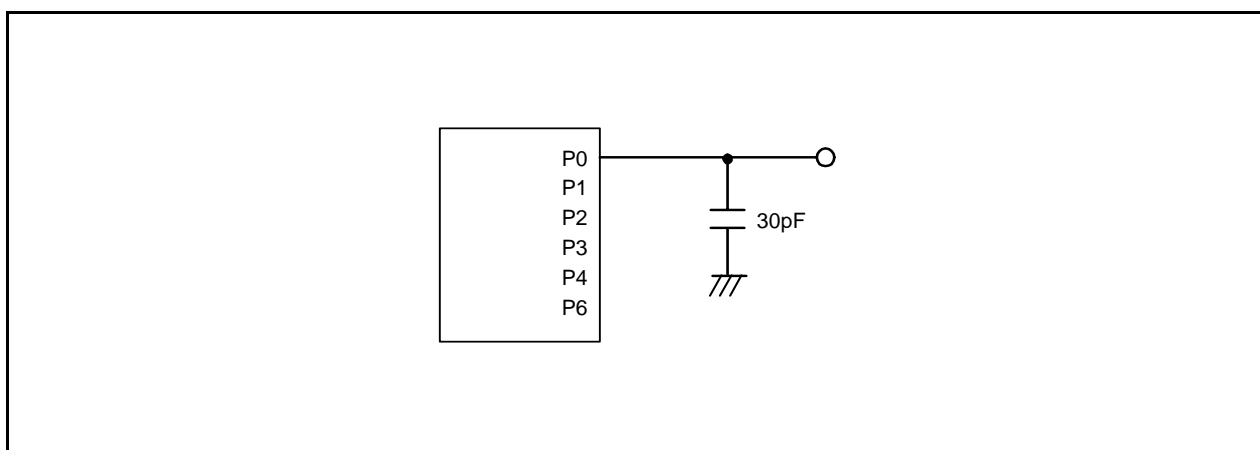
Table 20.5 Flash Memory (Data flash Block A, Block B) Electrical Characteristics⁽⁴⁾

Symbol	Parameter	Conditions	Standard			Unit
			Min.	Typ.	Max.	
–	Program/erase endurance ⁽²⁾		10,000 ⁽³⁾	–	–	times
–	Byte program time (program/erase endurance ≤ 1,000 times)		–	50	400	μs
–	Byte program time (program/erase endurance > 1,000 times)		–	65	–	μs
–	Block erase time (program/erase endurance ≤ 1,000 times)		–	0.2	9	s
–	Block erase time (program/erase endurance > 1,000 times)		–	0.3	–	s
t _d (SR-SUS)	Time delay from suspend request until suspend		–	–	97+CPU clock × 6 cycles	μs
–	Interval from erase start/restart until following suspend request		650	–	–	μs
–	Interval from program start/restart until following suspend request		0	–	–	ns
–	Time from suspend until program/erase restart		–	–	3+CPU clock × 4 cycles	μs
–	Program, erase voltage		2.7	–	5.5	V
–	Read voltage		2.2	–	5.5	V
–	Program, erase temperature		-20 ⁽⁸⁾	–	85	°C
–	Data hold time ⁽⁹⁾	Ambient temperature = 55 °C	20	–	–	year

NOTES:

- V_{CC} = 2.7 to 5.5 V at T_{opr} = -20 to 85°C (N version) / -40 to 85°C (D version), unless otherwise specified.
- Definition of programming/erasure endurance
The programming and erasure endurance is defined on a per-block basis.
If the programming and erasure endurance is n (n = 100 or 10,000), each block can be erased n times. For example, if 1,024 1-byte writes are performed to block A, a 1 Kbyte block, and then the block is erased, the programming/erasure endurance still stands at one.
However, the same address must not be programmed more than once per erase operation (overwriting prohibited).
- Endurance to guarantee all electrical characteristics after program and erase. (1 to Min. value can be guaranteed).
- Standard of block A and block B when program and erase endurance exceeds 1,000 times. Byte program time to 1,000 times is the same as that in program ROM.
- In a system that executes multiple programming operations, the actual erasure count can be reduced by writing to sequential addresses in turn so that as much of the block as possible is used up before performing an erase operation. For example, when programming groups of 16 bytes, the effective number of rewrites can be minimized by programming up to 128 groups before erasing them all in one operation. It is also advisable to retain data on the erase count of each block and limit the number of erase operations to a certain number.
- If an error occurs during block erase, attempt to execute the clear status register command, then execute the block erase command at least three times until the erase error does not occur.
- Customers desiring program/erase failure rate information should contact their Renesas technical support representative.
- 40°C for D version.
- The data hold time includes time that the power supply is off or the clock is not supplied.

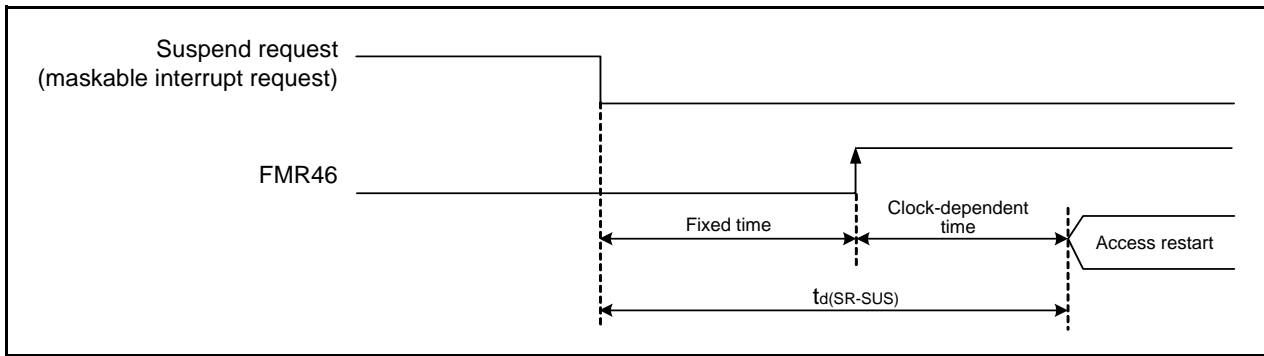

Figure 20.2 Time delay until Suspend

Table 20.6 Voltage Detection 0 Circuit Electrical Characteristics

Symbol	Parameter	Condition	Standard			Unit
			Min.	Typ.	Max.	
V _{det0}	Voltage detection level		2.2	2.3	2.4	V
–	Voltage detection circuit self power consumption	VCA25 = 1, V _{CC} = 5.0 V	–	0.9	–	μA
t _{d(E-A)}	Waiting time until voltage detection circuit operation starts ⁽²⁾		–	–	300	μs
V _{ccmin}	MCU operating voltage minimum value		2.2	–	–	V

NOTES:

1. The measurement condition is V_{CC} = 2.2 V to 5.5 V and T_{opr} = -20 to 85°C (N version) / -40 to 85°C (D version).
2. Necessary time until the voltage detection circuit operates when setting to 1 again after setting the VCA25 bit in the VCA2 register to 0.

Table 20.7 Voltage Detection 1 Circuit Electrical Characteristics

Symbol	Parameter	Condition	Standard			Unit
			Min.	Typ.	Max.	
V _{det1}	Voltage detection level		2.70	2.85	3.00	V
–	Voltage monitor 1 interrupt request generation time ⁽²⁾		–	40	–	μs
–	Voltage detection circuit self power consumption	VCA26 = 1, V _{CC} = 5.0 V	–	0.6	–	μA
t _{d(E-A)}	Waiting time until voltage detection circuit operation starts ⁽³⁾		–	–	100	μs

NOTES:

1. The measurement condition is V_{CC} = 2.2 V to 5.5 V and T_{opr} = -20 to 85°C (N version) / -40 to 85°C (D version).
2. Time until the voltage monitor 1 interrupt request is generated after the voltage passes V_{det1}.
3. Necessary time until the voltage detection circuit operates when setting to 1 again after setting the VCA26 bit in the VCA2 register to 0.

Table 20.8 Voltage Detection 2 Circuit Electrical Characteristics

Symbol	Parameter	Condition	Standard			Unit
			Min.	Typ.	Max.	
V _{det2}	Voltage detection level		3.3	3.6	3.9	V
–	Voltage monitor 2 interrupt request generation time ⁽²⁾		–	40	–	μs
–	Voltage detection circuit self power consumption	VCA27 = 1, V _{CC} = 5.0 V	–	0.6	–	μA
t _{d(E-A)}	Waiting time until voltage detection circuit operation starts ⁽³⁾		–	–	100	μs

NOTES:

1. The measurement condition is V_{CC} = 2.2 V to 5.5 V and T_{opr} = -20 to 85°C (N version) / -40 to 85°C (D version).
2. Time until the voltage monitor 2 interrupt request is generated after the voltage passes V_{det2}.
3. Necessary time until the voltage detection circuit operates after setting to 1 again after setting the VCA27 bit in the VCA2 register to 0.

Table 20.9 Power-on Reset Circuit, Voltage Monitor 0 Reset Electrical Characteristics⁽³⁾

Symbol	Parameter	Condition	Standard			Unit
			Min.	Typ.	Max.	
V _{por1}	Power-on reset valid voltage ⁽⁴⁾		–	–	0.1	V
V _{por2}	Power-on reset or voltage monitor 0 reset valid voltage		0	–	V _{det0}	V
tr _{th}	External power V _{CC} rise gradient ⁽²⁾		20	–	–	mV/msec

NOTES:

1. The measurement condition is T_{opr} = -20 to 85°C (N version) / -40 to 85°C (D version), unless otherwise specified.
2. This condition (external power V_{CC} rise gradient) does not apply if V_{CC} ≥ 1.0 V.
3. To use the power-on reset function, enable voltage monitor 0 reset by setting the LVD0ON bit in the OFS register to 0, the VW0C0 and VW0C6 bits in the VW0C register to 1 respectively, and the VCA25 bit in the VCA2 register to 1.
4. t_{w(por1)} indicates the duration the external power V_{CC} must be held below the effective voltage (V_{por1}) to enable a power on reset. When turning on the power for the first time, maintain t_{w(por1)} for 30 s or more if -20°C ≤ T_{opr} ≤ 85°C, maintain t_{w(por1)} for 3,000 s or more if -40°C ≤ T_{opr} < -20°C.

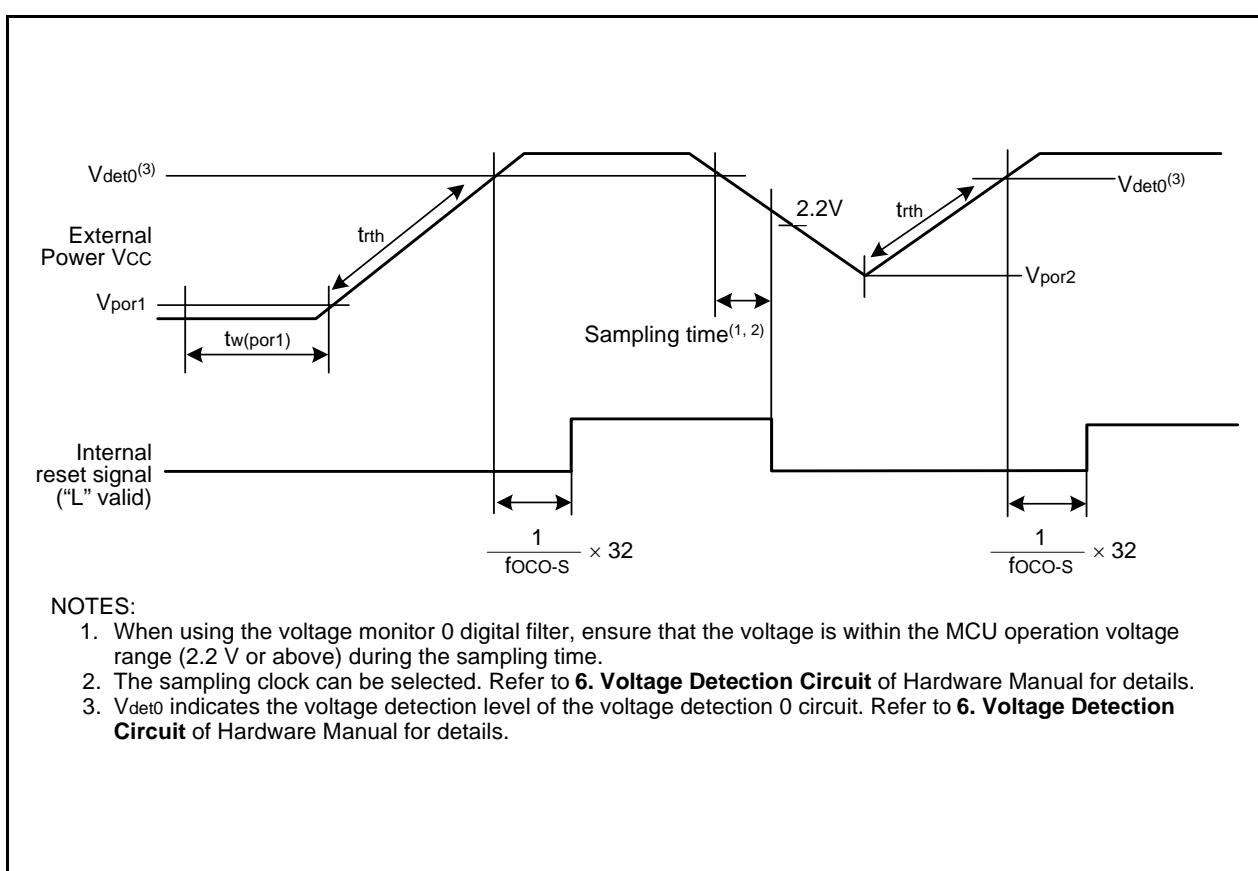

NOTES:

1. When using the voltage monitor 0 digital filter, ensure that the voltage is within the MCU operation voltage range (2.2 V or above) during the sampling time.
2. The sampling clock can be selected. Refer to **6. Voltage Detection Circuit** of Hardware Manual for details.
3. V_{det0} indicates the voltage detection level of the voltage detection 0 circuit. Refer to **6. Voltage Detection Circuit** of Hardware Manual for details.

Figure 20.3 Power-on Reset Circuit Electrical Characteristics

Table 20.10 High-speed On-Chip Oscillator Circuit Electrical Characteristics

Symbol	Parameter	Condition	Standard			Unit
			Min.	Typ.	Max.	
fOCO40M	High-speed on-chip oscillator frequency after reset	V _{CC} = 5.0 V, T _{opr} = 25°C	–	40	–	MHz
	High-speed on-chip oscillator temperature supply voltage dependence	V _{CC} = 4.75 V to 5.25 V 0°C ≤ T _{opr} ≤ 60°C ⁽²⁾	39.2	–	40.8	MHz
		V _{CC} = 4.5 V to 5.5 V –20°C ≤ T _{opr} ≤ 85°C	38.8	–	40.8	MHz
		V _{CC} = 4.5 V to 5.5 V –40°C ≤ T _{opr} ≤ 85°C	38.4	–	40.8	MHz
		V _{CC} = 3.0 V to 5.5 V –20°C ≤ T _{opr} ≤ 85°C ⁽²⁾	38.8	–	41.2	MHz
		V _{CC} = 3.0 V to 5.5 V –40°C ≤ T _{opr} ≤ 85°C ⁽²⁾	38.4	–	41.6	MHz
		V _{CC} = 2.7 V to 5.5 V –20°C ≤ T _{opr} ≤ 85°C ⁽²⁾	38	–	42	MHz
		V _{CC} = 2.7 V to 5.5 V –40°C ≤ T _{opr} ≤ 85°C ⁽²⁾	37.6	–	42.4	MHz
		V _{CC} = 2.2 V to 5.5 V –20°C ≤ T _{opr} ≤ 85°C ⁽³⁾	35.2	–	44.8	MHz
		V _{CC} = 2.2 V to 5.5 V –40°C ≤ T _{opr} ≤ 85°C ⁽³⁾	34	–	46	MHz
–		Value in FRA1 register after reset		08h	–	F7h
–	Oscillation frequency adjustment unit of high-speed on-chip oscillator	Adjust FRA1 register (value after reset) to -1	–	+0.3	–	MHz
–	Oscillation stability time		–	10	100	μs
–	Self power consumption at oscillation	V _{CC} = 5.0 V, T _{opr} = 25°C	–	400	–	μA

NOTES:

- V_{CC} = 2.2 to 5.5 V, T_{opr} = -20 to 85°C (N version) / -40 to 85°C (D version), unless otherwise specified.
- Standard values when the FRA1 register value after reset is assumed.
- Standard values when the corrected value of the FRA6 register has been written to the FRA1 register.

Table 20.11 Low-speed On-Chip Oscillator Circuit Electrical Characteristics

Symbol	Parameter	Condition	Standard			Unit
			Min.	Typ.	Max.	
fOCO-S	Low-speed on-chip oscillator frequency		30	125	250	kHz
–	Oscillation stability time		–	10	100	μs
–	Self power consumption at oscillation	V _{CC} = 5.0 V, T _{opr} = 25°C	–	15	–	μA

NOTE:

- V_{CC} = 2.2 to 5.5 V, T_{opr} = -20 to 85°C (N version) / -40 to 85°C (D version), unless otherwise specified.

Table 20.12 Power Supply Circuit Timing Characteristics

Symbol	Parameter	Condition	Standard			Unit
			Min.	Typ.	Max.	
t _d (P-R)	Time for internal power supply stabilization during power-on ⁽²⁾		1	–	2000	μs
t _d (R-S)	STOP exit time ⁽³⁾		–	–	150	μs

NOTES:

- The measurement condition is V_{CC} = 2.2 to 5.5 V and T_{opr} = 25°C.
- Waiting time until the internal power supply generation circuit stabilizes during power-on.
- Time until system clock supply starts after the interrupt is acknowledged to exit stop mode.

Table 20.13 Timing Requirements of Clock Synchronous Serial I/O with Chip Select⁽¹⁾

Symbol	Parameter		Conditions	Standard			Unit
				Min.	Typ.	Max.	
tsucyc	SSCK clock cycle time			4	–	–	tcyc ⁽²⁾
tHI	SSCK clock "H" width			0.4	–	0.6	tsucyc
tLO	SSCK clock "L" width			0.4	–	0.6	tsucyc
tRISE	SSCK clock rising time	Master		–	–	1	tcyc ⁽²⁾
		Slave		–	–	1	μs
tFALL	SSCK clock falling time	Master		–	–	1	tcyc ⁽²⁾
		Slave		–	–	1	μs
tsu	SSO, SSI data input setup time			100	–	–	ns
tH	SSO, SSI data input hold time			1	–	–	tcyc ⁽²⁾
tLEAD	$\overline{\text{SCS}}$ setup time	Slave		1tcyc + 50	–	–	ns
tLAG	$\overline{\text{SCS}}$ hold time	Slave		1tcyc + 50	–	–	ns
tOD	SSO, SSI data output delay time			–	–	1	tcyc ⁽²⁾
tSA	SSI slave access time		$2.7 \text{ V} \leq V_{\text{CC}} \leq 5.5 \text{ V}$	–	–	$1.5\text{tcyc} + 100$	ns
			$2.2 \text{ V} \leq V_{\text{CC}} < 2.7 \text{ V}$	–	–	$1.5\text{tcyc} + 200$	ns
tOR	SSI slave out open time		$2.7 \text{ V} \leq V_{\text{CC}} \leq 5.5 \text{ V}$	–	–	$1.5\text{tcyc} + 100$	ns
			$2.2 \text{ V} \leq V_{\text{CC}} < 2.7 \text{ V}$	–	–	$1.5\text{tcyc} + 200$	ns

NOTES:

1. $V_{\text{CC}} = 2.2$ to 5.5 V , $V_{\text{SS}} = 0 \text{ V}$ at $T_{\text{opr}} = -20$ to 85°C (N version) / -40 to 85°C (D version), unless otherwise specified.
2. $1\text{tcyc} = 1/f_1(\text{s})$

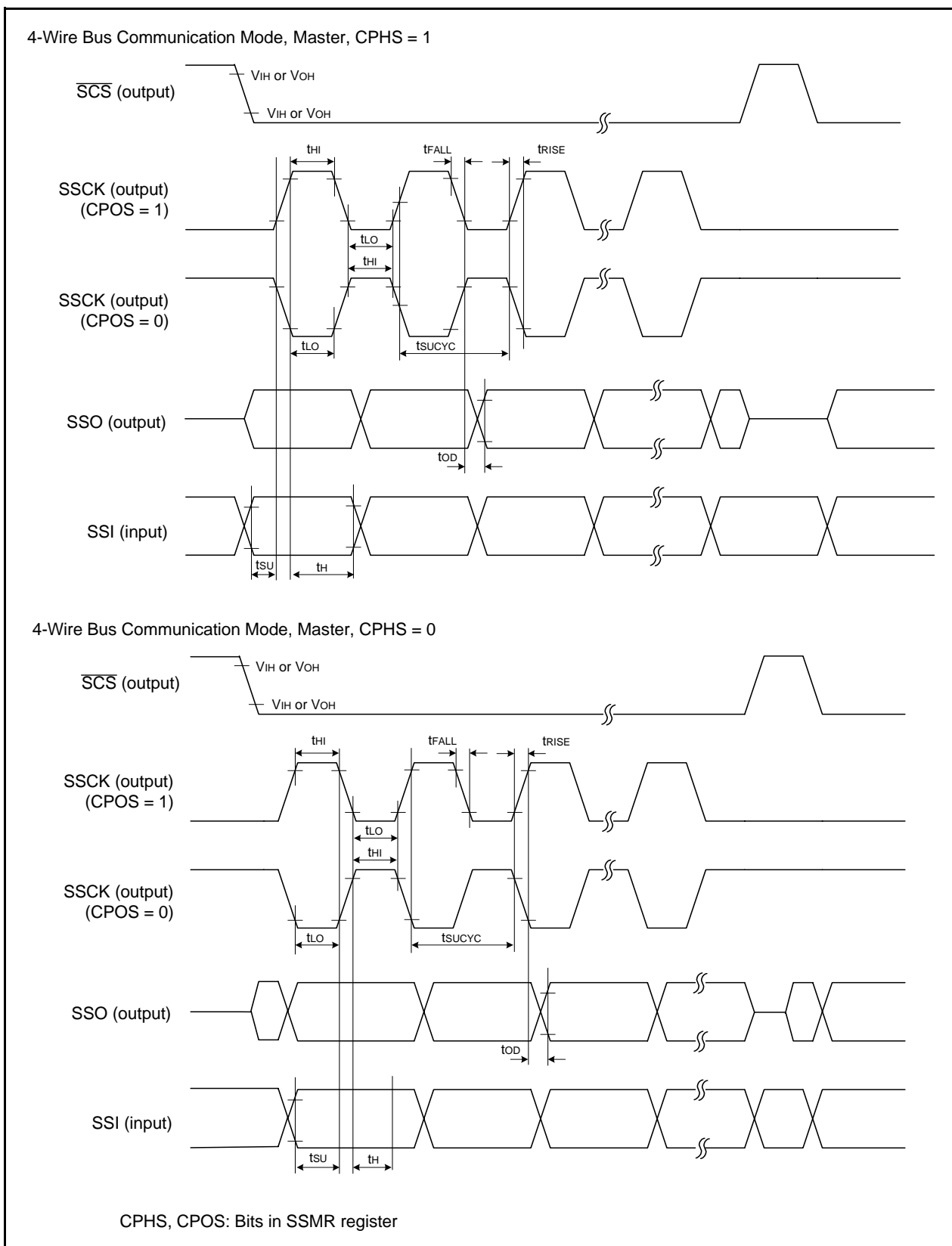

Figure 20.4 I/O Timing of Clock Synchronous Serial I/O with Chip Select (Master)

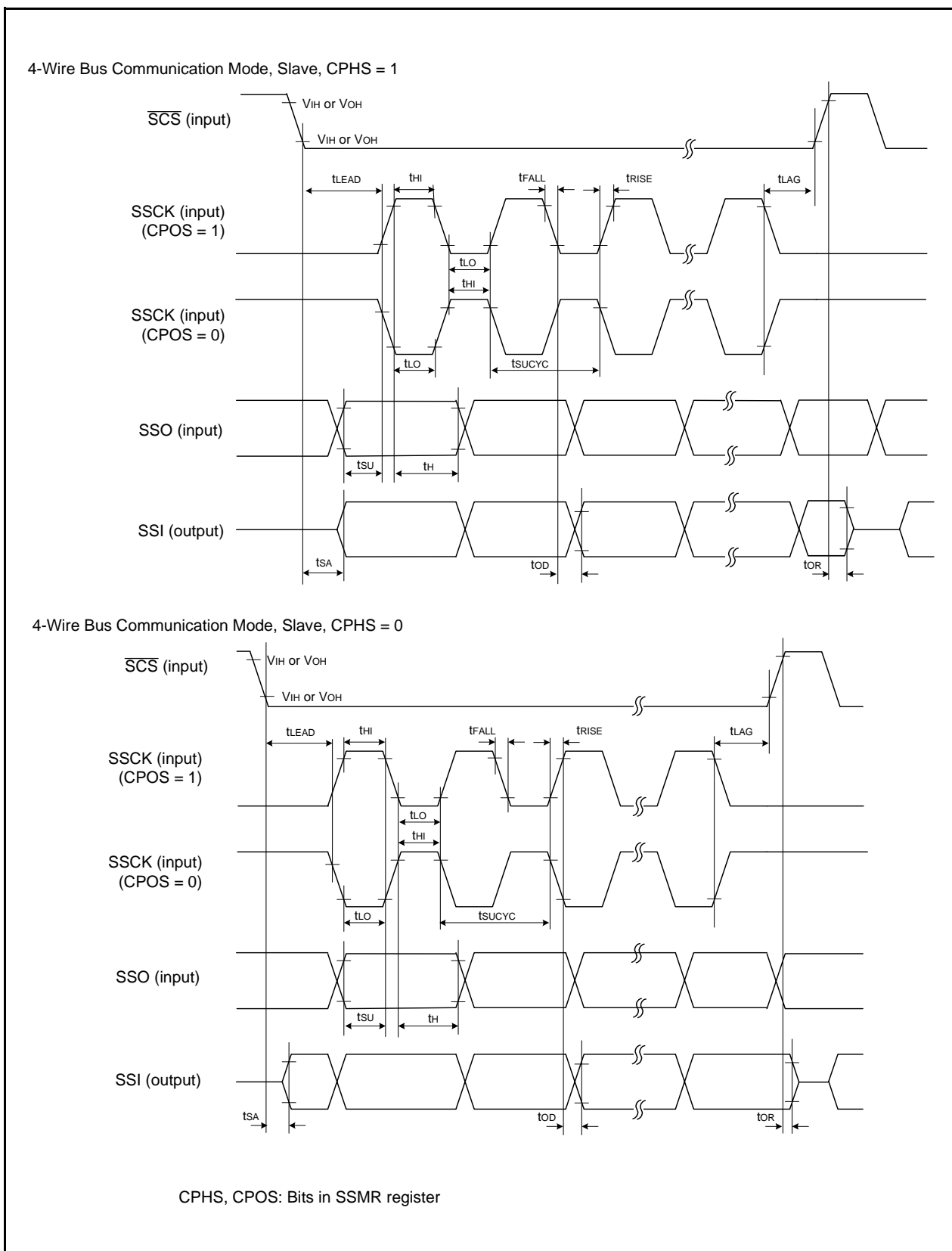

Figure 20.5 I/O Timing of Clock Synchronous Serial I/O with Chip Select (Slave)

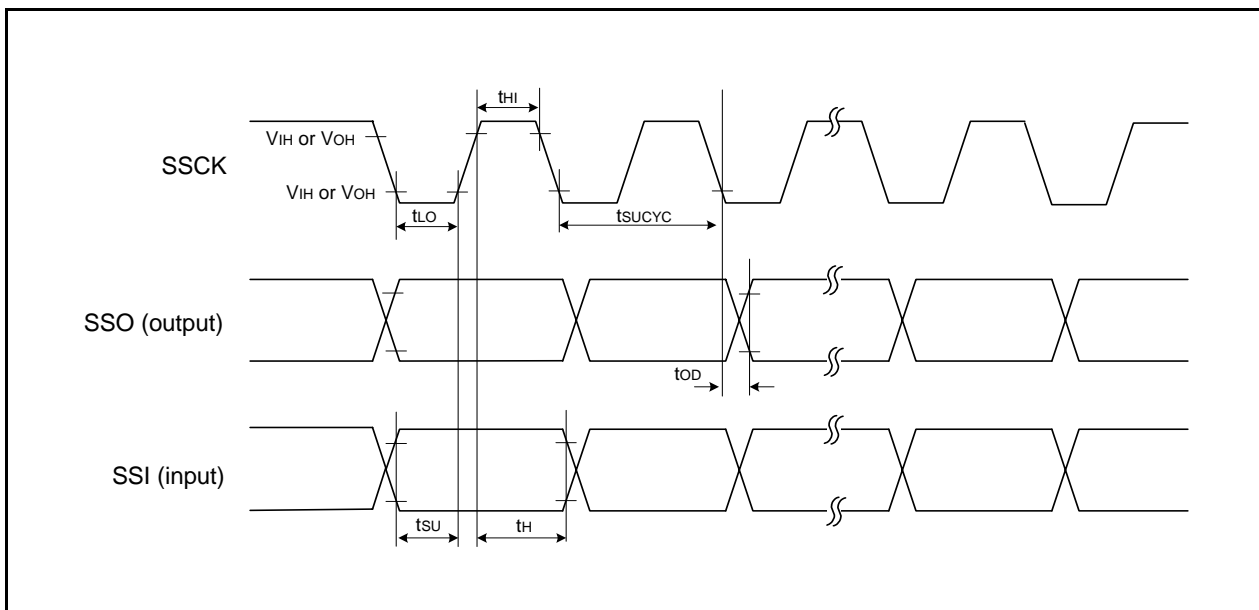

Figure 20.6 I/O Timing of Clock Synchronous Serial I/O with Chip Select (Clock Synchronous Communication Mode)

Table 20.14 Timing Requirements of I²C bus Interface (1)

Symbol	Parameter	Condition	Standard			Unit
			Min.	Typ.	Max.	
tSCL	SCL input cycle time		12tcyc + 600 ⁽²⁾	–	–	ns
tSCLH	SCL input “H” width		3tcyc + 300 ⁽²⁾	–	–	ns
tSCLL	SCL input “L” width		5tcyc + 500 ⁽²⁾	–	–	ns
tsf	SCL, SDA input fall time		–	–	300	ns
tSP	SCL, SDA input spike pulse rejection time		–	–	1tcyc ⁽²⁾	ns
tBUF	SDA input bus-free time		5tcyc ⁽²⁾	–	–	ns
tSTAH	Start condition input hold time		3tcyc ⁽²⁾	–	–	ns
tSTAS	Retransmit start condition input setup time		3tcyc ⁽²⁾	–	–	ns
tSTOP	Stop condition input setup time		3tcyc ⁽²⁾	–	–	ns
tSDAS	Data input setup time		1tcyc + 20 ⁽²⁾	–	–	ns
tSDAH	Data input hold time		0	–	–	ns

NOTES:

1. VCC = 2.2 to 5.5 V, VSS = 0 V and Topr = -20 to 85°C (N version) / -40 to 85°C (D version), unless otherwise specified.
2. 1tcyc = 1/f1(s)

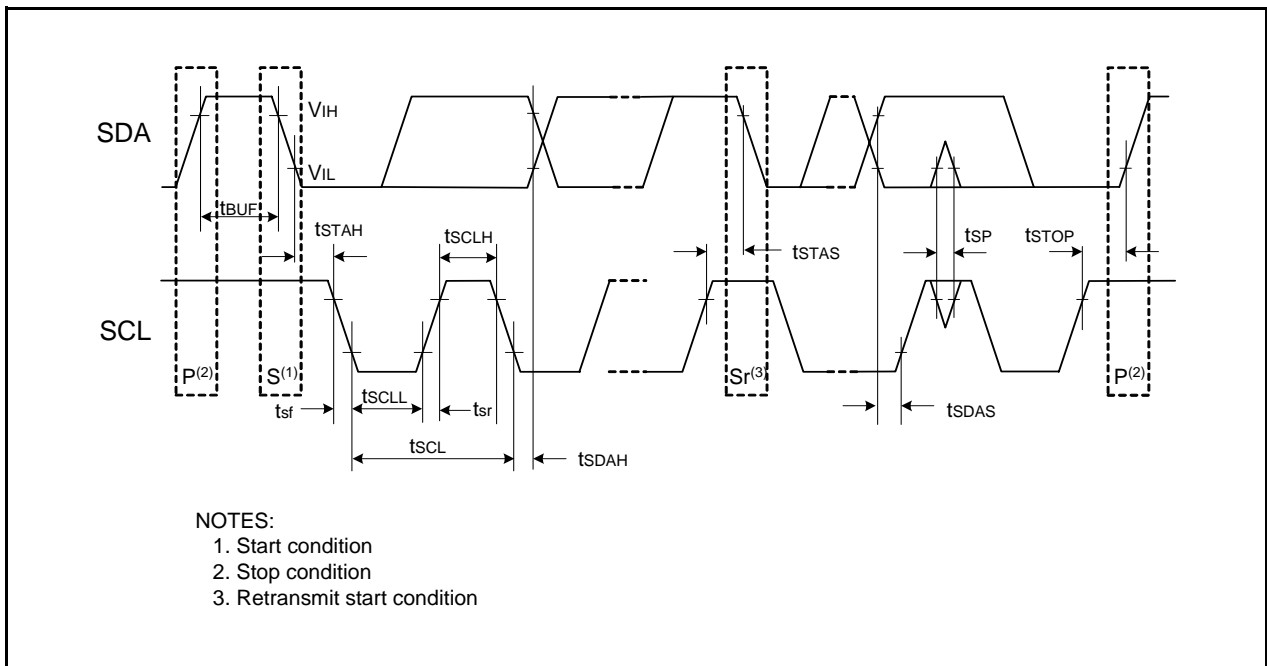

Figure 20.7 I/O Timing of I²C bus Interface

Table 20.15 Electrical Characteristics (1) [V_{CC} = 5 V]

Symbol	Parameter		Condition	Standard			Unit		
				Min.	Typ.	Max.			
V _{OH}	Output "H" voltage	Except P2_0 to P2_7, XOUT	I _{OH} = -5 mA		V _{CC} - 2.0	-	V _{CC}	V	
			I _{OH} = -200 μA		V _{CC} - 0.5	-	V _{CC}	V	
	P2_0 to P2_7		Drive capacity HIGH	I _{OH} = -20 mA	V _{CC} - 2.0	-	V _{CC}	V	
			Drive capacity LOW	I _{OH} = -5 mA	V _{CC} - 2.0	-	V _{CC}	V	
	XOUT		Drive capacity HIGH	I _{OH} = -1 mA	V _{CC} - 2.0	-	V _{CC}	V	
			Drive capacity LOW	I _{OH} = -500 μA	V _{CC} - 2.0	-	V _{CC}	V	
V _{OL}	Output "L" voltage	Except P2_0 to P2_7, XOUT	I _{OL} = 5 mA		-	-	2.0	V	
			I _{OL} = 200 μA		-	-	0.45	V	
	P2_0 to P2_7		Drive capacity HIGH	I _{OL} = 20 mA	-	-	2.0	V	
			Drive capacity LOW	I _{OL} = 5 mA	-	-	2.0	V	
	XOUT		Drive capacity HIGH	I _{OL} = 1 mA	-	-	2.0	V	
			Drive capacity LOW	I _{OL} = 500 μA	-	-	2.0	V	
V _{T+} -V _{T-}	Hysteresis	INT0, INT1, INT2, INT3, KI0, KI1, KI2, KI3, TRAIO, RXD0, RXD1, CLK0, CLK1, SSI, SCL, SDA, SSO			0.1	0.5	-	V	
		RESET			0.1	1.0	-	V	
I _{IH}	Input "H" current			V _I = 5 V, V _{CC} = 5V		-	-	5.0	μA
I _{IL}	Input "L" current			V _I = 0 V, V _{CC} = 5V		-	-	-5.0	μA
R _{PULLUP}	Pull-up resistance			V _I = 0 V, V _{CC} = 5V		30	50	167	kΩ
R _{IXIN}	Feedback resistance	XIN			-	1.0	-		MΩ
R _{IXCIN}	Feedback resistance	XCIN			-	18	-		MΩ
V _{RAM}	RAM hold voltage			During stop mode		1.8	-	-	V

NOTE:

- V_{CC} = 4.2 to 5.5 V at T_{opr} = -20 to 85°C (N version) / -40 to 85°C (D version), f(XIN) = 20 MHz, unless otherwise specified.

**Table 20.16 Electrical Characteristics (2) [V_{CC} = 5 V]
(T_{opr} = -20 to 85°C (N version) / -40 to 85°C (D version), unless otherwise specified.)**

Symbol	Parameter	Condition	Standard			Unit	
			Min.	Typ.	Max.		
I _{CC}	Power supply current (V _{CC} = 3.3 to 5.5 V) Single-chip mode, output pins are open, other pins are V _{SS}	High-speed clock mode	XIN = 20 MHz (square wave) High-speed on-chip oscillator off Low-speed on-chip oscillator on = 125 kHz No division	–	10	17	mA
			XIN = 16 MHz (square wave) High-speed on-chip oscillator off Low-speed on-chip oscillator on = 125 kHz No division	–	9	15	mA
			XIN = 10 MHz (square wave) High-speed on-chip oscillator off Low-speed on-chip oscillator on = 125 kHz No division	–	6	–	mA
			XIN = 20 MHz (square wave) High-speed on-chip oscillator off Low-speed on-chip oscillator on = 125 kHz Divide-by-8	–	5	–	mA
			XIN = 16 MHz (square wave) High-speed on-chip oscillator off Low-speed on-chip oscillator on = 125 kHz Divide-by-8	–	4	–	mA
			XIN = 10 MHz (square wave) High-speed on-chip oscillator off Low-speed on-chip oscillator on = 125 kHz Divide-by-8	–	2.5	–	mA
			High-speed on-chip oscillator mode	XIN clock off High-speed on-chip oscillator on f _{OCO} = 20 MHz Low-speed on-chip oscillator on = 125 kHz No division	–	10	15
		XIN clock off High-speed on-chip oscillator on f _{OCO} = 20 MHz Low-speed on-chip oscillator on = 125 kHz Divide-by-8		–	4	–	mA
		XIN clock off High-speed on-chip oscillator on f _{OCO} = 10 MHz Low-speed on-chip oscillator on = 125 kHz No division		–	5.5	10	mA
		XIN clock off High-speed on-chip oscillator on f _{OCO} = 10 MHz Low-speed on-chip oscillator on = 125 kHz Divide-by-8		–	2.5	–	mA
		Low-speed on-chip oscillator mode	XIN clock off High-speed on-chip oscillator off Low-speed on-chip oscillator on = 125 kHz Divide-by-8, FMR47 = 1	–	130	300	μA
			Low-speed clock mode	XIN clock off High-speed on-chip oscillator off Low-speed on-chip oscillator off XCIN clock oscillator on = 32 kHz FMR47 = 1	–	130	300
				XIN clock off High-speed on-chip oscillator off Low-speed on-chip oscillator off XCIN clock oscillator on = 32 kHz Program operation on RAM Flash memory off, FMSTP = 1	–	30	–

Table 20.17 Electrical Characteristics (3) [V_{CC} = 5 V]
(T_{opr} = -20 to 85°C (N version) / -40 to 85°C (D version), unless otherwise specified.)

Symbol	Parameter	Condition	Standard			Unit	
			Min.	Typ.	Max.		
I _{CC}	Power supply current (V _{CC} = 3.3 to 5.5 V) Single-chip mode, output pins are open, other pins are V _{SS}	Wait mode	XIN clock off High-speed on-chip oscillator off Low-speed on-chip oscillator on = 125 kHz While a WAIT instruction is executed Peripheral clock operation VCA27 = VCA26 = VCA25 = 0 VCA20 = 1	–	25	75	μA
			XIN clock off High-speed on-chip oscillator off Low-speed on-chip oscillator on = 125 kHz While a WAIT instruction is executed Peripheral clock off VCA27 = VCA26 = VCA25 = 0 VCA20 = 1	–	23	60	μA
			XIN clock off High-speed on-chip oscillator off Low-speed on-chip oscillator off XCIN clock oscillator on = 32 kHz (high drive) While a WAIT instruction is executed VCA27 = VCA26 = VCA25 = 0 VCA20 = 1	–	4.0	–	μA
			XIN clock off High-speed on-chip oscillator off Low-speed on-chip oscillator off XCIN clock oscillator on = 32 kHz (low drive) While a WAIT instruction is executed VCA27 = VCA26 = VCA25 = 0 VCA20 = 1	–	2.2	–	μA
		Increase during	Without sample & hold	–	2.6	–	mA
		A/D converter operation	With sample & hold	–	1.6	–	mA
		Stop mode	XIN clock off, T _{opr} = 25°C High-speed on-chip oscillator off Low-speed on-chip oscillator off CM10 = 1 Peripheral clock off VCA27 = VCA26 = VCA25 = 0	–	0.8	3.0	μA
			XIN clock off, T _{opr} = 85°C High-speed on-chip oscillator off Low-speed on-chip oscillator off CM10 = 1 Peripheral clock off VCA27 = VCA26 = VCA25 = 0	–	1.2	–	μA

Timing Requirements**(Unless Otherwise Specified: $V_{CC} = 5\text{ V}$, $V_{SS} = 0\text{ V}$ at $T_{op} = 25^\circ\text{C}$) [$V_{CC} = 5\text{ V}$]****Table 20.18 XIN Input, XCIN Input**

Symbol	Parameter	Standard		Unit
		Min.	Max.	
$t_{c(XIN)}$	XIN input cycle time	50	–	ns
$t_{WH(XIN)}$	XIN input "H" width	25	–	ns
$t_{WL(XIN)}$	XIN input "L" width	25	–	ns
$t_{c(XCIN)}$	XCIN input cycle time	14	–	μs
$t_{WH(XCIN)}$	XCIN input "H" width	7	–	μs
$t_{WL(XCIN)}$	XCIN input "L" width	7	–	μs

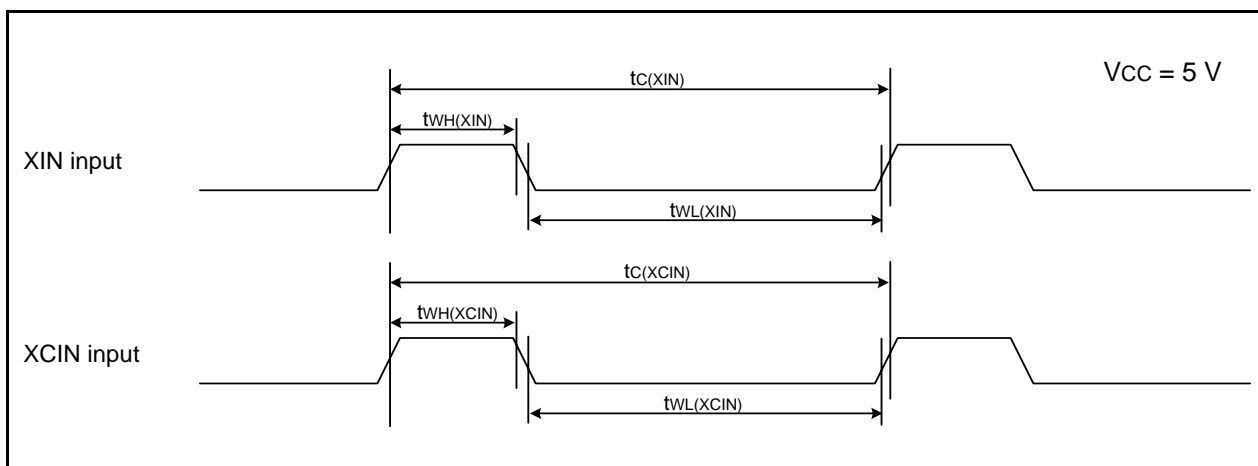
**Figure 20.8 XIN Input and XCIN Input Timing Diagram when $V_{CC} = 5\text{ V}$** **Table 20.19 TRAIO Input**

Symbol	Parameter	Standard		Unit
		Min.	Max.	
$t_{c(TRAIO)}$	TRAIO input cycle time	100	–	ns
$t_{WH(TRAIO)}$	TRAIO input "H" width	40	–	ns
$t_{WL(TRAIO)}$	TRAIO input "L" width	40	–	ns

**Figure 20.9 TRAIO Input Timing Diagram when $V_{CC} = 5\text{ V}$**

Table 20.20 Serial Interface

Symbol	Parameter	Standard		Unit
		Min.	Max.	
$t_{c(CK)}$	CLKi input cycle time	200	–	ns
$t_{w(CKH)}$	CLKi input “H” width	100	–	ns
$t_{w(CKL)}$	CLKi input “L” width	100	–	ns
$t_{d(C-Q)}$	TXDi output delay time	–	50	ns
$t_{h(C-Q)}$	TXDi hold time	0	–	ns
$t_{su(D-C)}$	RXDi input setup time	50	–	ns
$t_{h(C-D)}$	RXDi input hold time	90	–	ns

i = 0 or 1

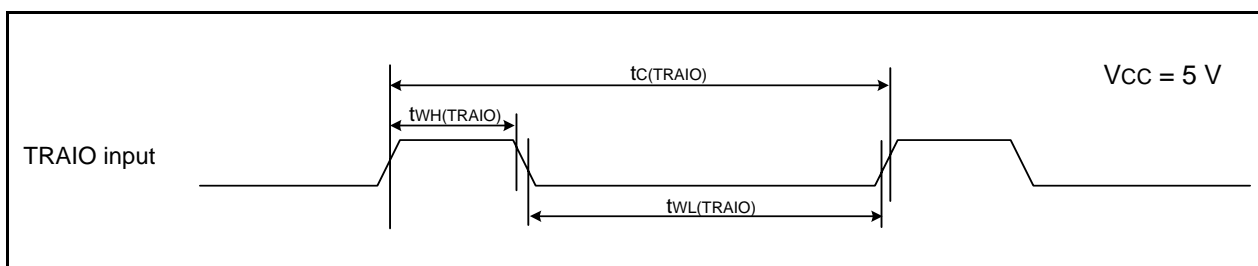
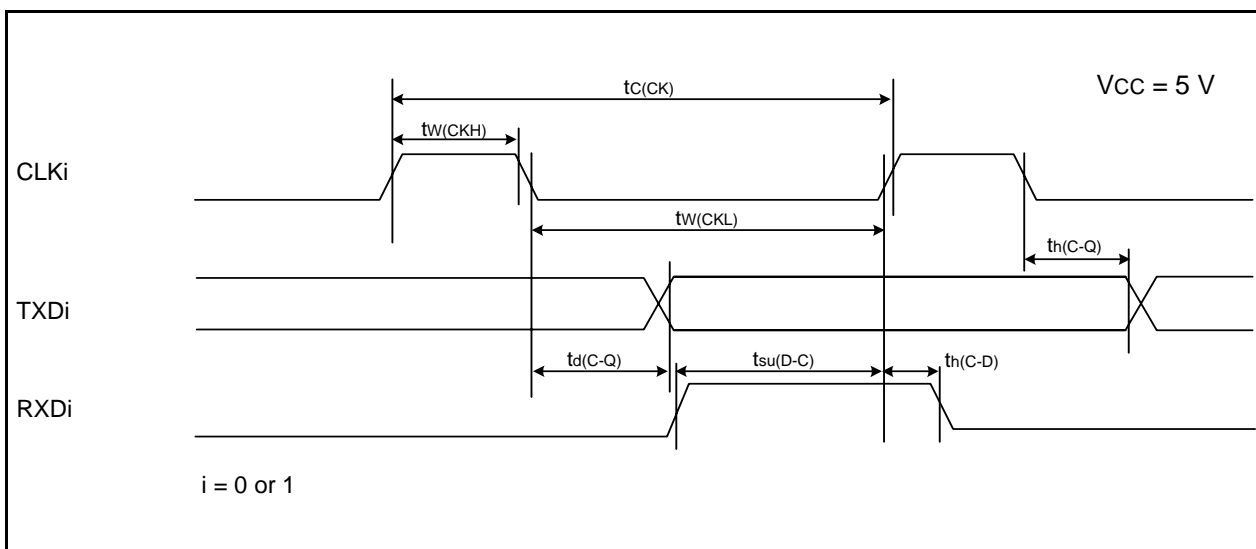

Figure 20.10 Serial Interface Timing Diagram when Vcc = 5 V

Table 20.21 External Interrupt \overline{INTi} (i = 0 to 3) Input

Symbol	Parameter	Standard		Unit
		Min.	Max.	
$t_{w(INH)}$	$\overline{INT0}$ input “H” width	250 ⁽¹⁾	–	ns
$t_{w(INL)}$	$\overline{INT0}$ input “L” width	250 ⁽²⁾	–	ns

NOTES:

1. When selecting the digital filter by the \overline{INTi} input filter select bit, use an \overline{INTi} input HIGH width of either (1/digital filter clock frequency × 3) or the minimum value of standard, whichever is greater.
2. When selecting the digital filter by the \overline{INTi} input filter select bit, use an \overline{INTi} input LOW width of either (1/digital filter clock frequency × 3) or the minimum value of standard, whichever is greater.

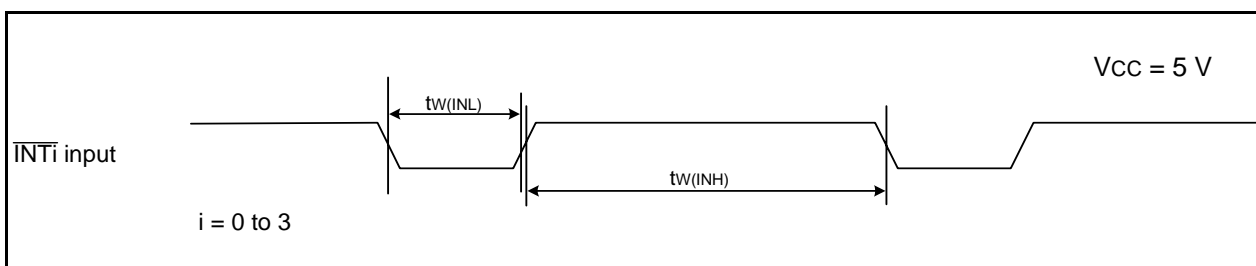

Figure 20.11 External Interrupt \overline{INTi} Input Timing Diagram when Vcc = 5 V

Table 20.22 Electrical Characteristics (3) [V_{CC} = 3 V]

Symbol	Parameter		Condition		Standard			Unit
					Min.	Typ.	Max.	
V _{OH}	Output "H" voltage	Except P2_0 to P2_7, XOUT	I _{OH} = -1 mA		V _{CC} - 0.5	-	V _{CC}	V
		P2_0 to P2_7	Drive capacity HIGH	I _{OH} = -5 mA	V _{CC} - 0.5	-	V _{CC}	V
			Drive capacity LOW	I _{OH} = -1 mA	V _{CC} - 0.5	-	V _{CC}	V
		XOUT	Drive capacity HIGH	I _{OH} = -0.1 mA	V _{CC} - 0.5	-	V _{CC}	V
			Drive capacity LOW	I _{OH} = -50 μA	V _{CC} - 0.5	-	V _{CC}	V
V _{OL}	Output "L" voltage	Except P2_0 to P2_7, XOUT	I _{OL} = 1 mA		-	-	0.5	V
		P2_0 to P2_7	Drive capacity HIGH	I _{OL} = 5 mA	-	-	0.5	V
			Drive capacity LOW	I _{OL} = 1 mA	-	-	0.5	V
		XOUT	Drive capacity HIGH	I _{OL} = 0.1 mA	-	-	0.5	V
			Drive capacity LOW	I _{OL} = 50 μA	-	-	0.5	V
V _{T+} -V _{T-}	Hysteresis	$\overline{\text{INT0}}, \overline{\text{INT1}}, \overline{\text{INT2}}, \overline{\text{INT3}}, \text{KI0}, \text{KI1}, \text{KI2}, \text{KI3}, \text{TRAIO}, \text{RXD0}, \text{RXD1}, \text{CLK0}, \text{CLK1}, \text{SSI}, \text{SCL}, \text{SDA}, \text{SSO}$			0.1	0.3	-	V
		$\overline{\text{RESET}}$			0.1	0.4	-	V
I _{IH}	Input "H" current	V _I = 3 V, V _{CC} = 3V		-	-	4.0	μA	
I _{IL}	Input "L" current	V _I = 0 V, V _{CC} = 3V		-	-	-4.0	μA	
R _{PULLUP}	Pull-up resistance	V _I = 0 V, V _{CC} = 3V		66	160	500	kΩ	
R _{IXIN}	Feedback resistance	XIN			-	3.0	-	MΩ
R _{IXCIN}	Feedback resistance	XCIN			-	18	-	MΩ
V _{RAM}	RAM hold voltage	During stop mode		1.8	-	-	V	

NOTE:

- V_{CC} = 2.7 to 3.3 V at T_{opr} = -20 to 85°C (N version) / -40 to 85°C (D version), f(XIN) = 10 MHz, unless otherwise specified.

**Table 20.23 Electrical Characteristics (4) [V_{CC} = 3 V]
(T_{opr} = -20 to 85°C (N version) / -40 to 85°C (D version), unless otherwise specified.)**

Symbol	Parameter	Condition	Standard			Unit	
			Min.	Typ.	Max.		
I _{CC}	Power supply current (V _{CC} = 2.7 to 3.3 V) Single-chip mode, output pins are open, other pins are V _{SS}	High-speed clock mode	XIN = 10 MHz (square wave) High-speed on-chip oscillator off Low-speed on-chip oscillator on = 125 kHz No division	–	6	–	mA
			XIN = 10 MHz (square wave) High-speed on-chip oscillator off Low-speed on-chip oscillator on = 125 kHz Divide-by-8	–	2	–	mA
		High-speed on-chip oscillator mode	XIN clock off High-speed on-chip oscillator on f _{OCO} = 10 MHz Low-speed on-chip oscillator on = 125 kHz No division	–	5	9	mA
			XIN clock off High-speed on-chip oscillator on f _{OCO} = 10 MHz Low-speed on-chip oscillator on = 125 kHz Divide-by-8	–	2	–	mA
		Low-speed on-chip oscillator mode	XIN clock off High-speed on-chip oscillator off Low-speed on-chip oscillator on = 125 kHz Divide-by-8, FMR47 = 1	–	130	300	μA
		Low-speed clock mode	XIN clock off High-speed on-chip oscillator off Low-speed on-chip oscillator off XCIN clock oscillator on = 32 kHz FMR47 = 1	–	130	300	μA
			XIN clock off High-speed on-chip oscillator off Low-speed on-chip oscillator off XCIN clock oscillator on = 32 kHz Program operation on RAM Flash memory off, FMSTP = 1	–	30	–	μA
		Wait mode	XIN clock off High-speed on-chip oscillator off Low-speed on-chip oscillator on = 125 kHz While a WAIT instruction is executed Peripheral clock operation VCA27 = VCA26 = VCA25 = 0 VCA20 = 1	–	25	70	μA
			XIN clock off High-speed on-chip oscillator off Low-speed on-chip oscillator on = 125 kHz While a WAIT instruction is executed Peripheral clock off VCA27 = VCA26 = VCA25 = 0 VCA20 = 1	–	23	55	μA
			XIN clock off High-speed on-chip oscillator off Low-speed on-chip oscillator off XCIN clock oscillator on = 32 kHz (high drive) While a WAIT instruction is executed VCA27 = VCA26 = VCA25 = 0 VCA20 = 1	–	3.8	–	μA
			XIN clock off High-speed on-chip oscillator off Low-speed on-chip oscillator off XCIN clock oscillator on = 32 kHz (low drive) While a WAIT instruction is executed VCA27 = VCA26 = VCA25 = 0 VCA20 = 1	–	2.0	–	μA
		Increase during A/D converter operation	Without sample & hold	–	0.9	–	mA
			With sample & hold	–	0.5	–	mA
		Stop mode	XIN clock off, T _{opr} = 25°C High-speed on-chip oscillator off Low-speed on-chip oscillator off CM10 = 1 Peripheral clock off VCA27 = VCA26 = VCA25 = 0	–	0.7	3.0	μA
			XIN clock off, T _{opr} = 85°C High-speed on-chip oscillator off Low-speed on-chip oscillator off CM10 = 1 Peripheral clock off VCA27 = VCA26 = VCA25 = 0	–	1.1	–	μA

Timing requirements**(Unless Otherwise Specified: $V_{CC} = 3\text{ V}$, $V_{SS} = 0\text{ V}$ at $T_{\text{opr}} = 25^{\circ}\text{C}$) [$V_{CC} = 3\text{ V}$]****Table 20.24 XIN Input, XCIN Input**

Symbol	Parameter	Standard		Unit
		Min.	Max.	
$t_{c(\text{XIN})}$	XIN input cycle time	100	–	ns
$t_{\text{WH}(\text{XIN})}$	XIN input "H" width	40	–	ns
$t_{\text{WL}(\text{XIN})}$	XIN input "L" width	40	–	ns
$t_{c(\text{XCIN})}$	XCIN input cycle time	14	–	μs
$t_{\text{WH}(\text{XCIN})}$	XCIN input "H" width	7	–	μs
$t_{\text{WL}(\text{XCIN})}$	XCIN input "L" width	7	–	μs

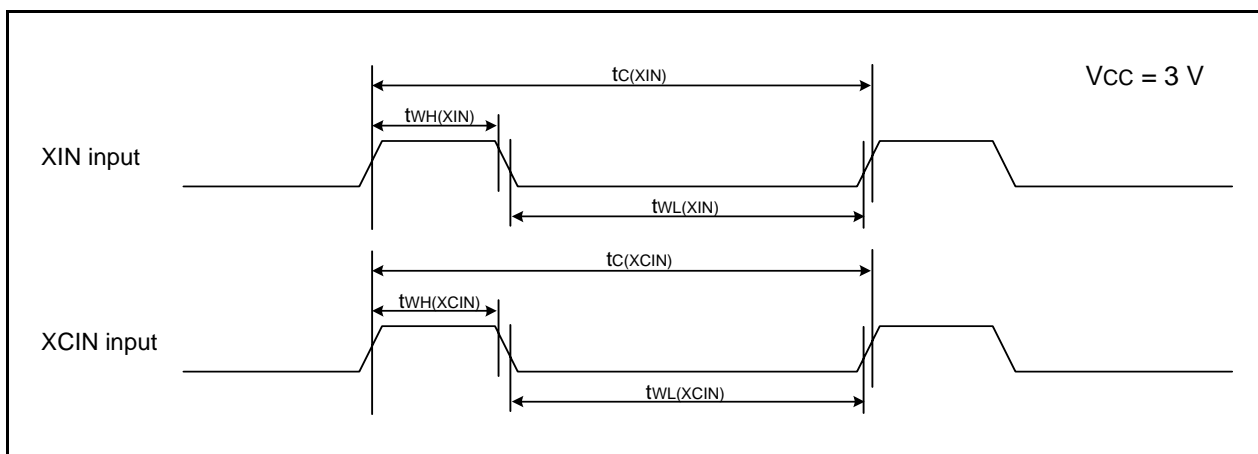
**Figure 20.12 XIN Input and XCIN Input Timing Diagram when $V_{CC} = 3\text{ V}$** **Table 20.25 TRAI0 Input**

Symbol	Parameter	Standard		Unit
		Min.	Max.	
$t_{c(\text{TRAIO})}$	TRAIO input cycle time	300	–	ns
$t_{\text{WH}(\text{TRAIO})}$	TRAIO input "H" width	120	–	ns
$t_{\text{WL}(\text{TRAIO})}$	TRAIO input "L" width	120	–	ns

**Figure 20.13 TRAI0 Input Timing Diagram when $V_{CC} = 3\text{ V}$**

Table 20.26 Serial Interface

Symbol	Parameter	Standard		Unit
		Min.	Max.	
$t_{c(CK)}$	CLKi input cycle time	300	–	ns
$t_{w(CKH)}$	CLKi input “H” width	150	–	ns
$t_{w(CKL)}$	CLKi Input “L” width	150	–	ns
$t_{d(C-Q)}$	TXDi output delay time	–	80	ns
$t_{h(C-Q)}$	TXDi hold time	0	–	ns
$t_{su(D-C)}$	RXD _i input setup time	70	–	ns
$t_{h(C-D)}$	RXD _i input hold time	90	–	ns

i = 0 or 1

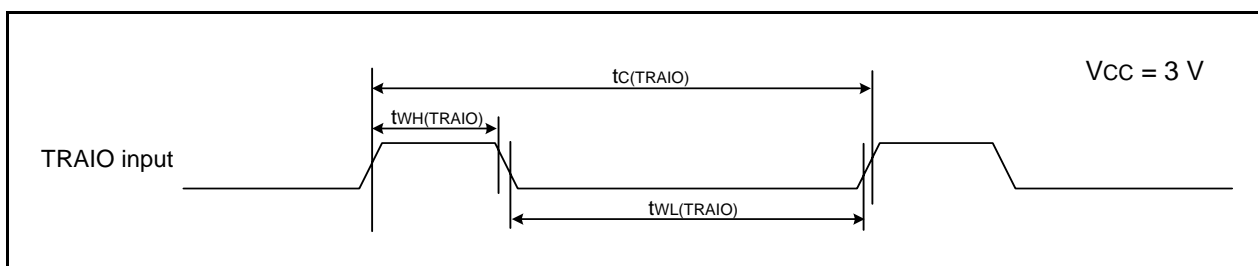
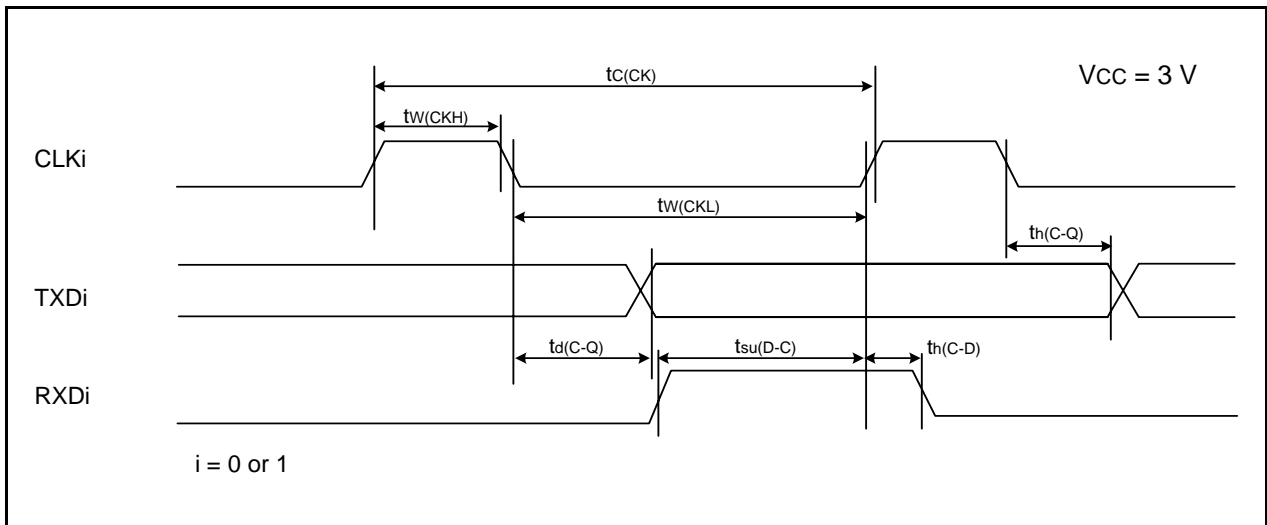

Figure 20.14 Serial Interface Timing Diagram when Vcc = 3 V

Table 20.27 External Interrupt INT_i (i = 0 to 3) Input

Symbol	Parameter	Standard		Unit
		Min.	Max.	
$t_{w(INH)}$	$\overline{INT0}$ input “H” width	380 ⁽¹⁾	–	ns
$t_{w(INL)}$	$\overline{INT0}$ input “L” width	380 ⁽²⁾	–	ns

NOTES:

1. When selecting the digital filter by the \overline{INTi} input filter select bit, use an \overline{INTi} input HIGH width of either (1/digital filter clock frequency × 3) or the minimum value of standard, whichever is greater.
2. When selecting the digital filter by the \overline{INTi} input filter select bit, use an \overline{INTi} input LOW width of either (1/digital filter clock frequency × 3) or the minimum value of standard, whichever is greater.

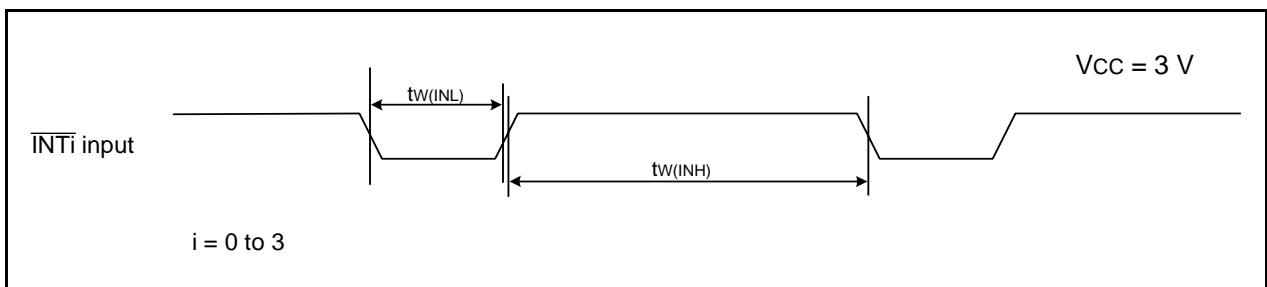

Figure 20.15 External Interrupt INT_i Input Timing Diagram when Vcc = 3 V

Table 20.28 Electrical Characteristics (5) [V_{CC} = 2.2 V]

Symbol	Parameter		Condition		Standard			Unit
					Min.	Typ.	Max.	
V _{OH}	Output "H" voltage	Except P2_0 to P2_7, XOUT	I _{OH} = -1 mA		V _{CC} - 0.5	–	V _{CC}	V
		P2_0 to P2_7	Drive capacity HIGH	I _{OH} = -2 mA	V _{CC} - 0.5	–	V _{CC}	V
			Drive capacity LOW	I _{OH} = -1 mA	V _{CC} - 0.5	–	V _{CC}	V
		XOUT	Drive capacity HIGH	I _{OH} = -0.1 mA	V _{CC} - 0.5	–	V _{CC}	V
			Drive capacity LOW	I _{OH} = -50 μA	V _{CC} - 0.5	–	V _{CC}	V
V _{OL}	Output "L" voltage	Except P2_0 to P2_7, XOUT	I _{OL} = 1 mA		–	–	0.5	V
		P2_0 to P2_7	Drive capacity HIGH	I _{OL} = 2 mA	–	–	0.5	V
			Drive capacity LOW	I _{OL} = 1 mA	–	–	0.5	V
		XOUT	Drive capacity HIGH	I _{OL} = 0.1 mA	–	–	0.5	V
			Drive capacity LOW	I _{OL} = 50 μA	–	–	0.5	V
V _{T+} -V _{T-}	Hysteresis	$\overline{\text{INT0}}, \overline{\text{INT1}}, \overline{\text{INT2}}, \overline{\text{INT3}}, \text{KI0}, \text{KI1}, \text{KI2}, \text{KI3}, \text{TRAIO}, \text{RXD0}, \text{RXD1}, \text{CLK0}, \text{CLK1}, \text{SSI}, \text{SCL}, \text{SDA}, \text{SSO}$			0.05	0.3	–	V
		$\overline{\text{RESET}}$			0.05	0.15	–	V
I _{IH}	Input "H" current			V _I = 2.2 V	–	–	4.0	μA
I _{IL}	Input "L" current			V _I = 0 V	–	–	-4.0	μA
R _{PULLUP}	Pull-up resistance			V _I = 0 V	100	200	600	kΩ
R _{IXIN}	Feedback resistance	XIN			–	5	–	MΩ
R _{IXCIN}	Feedback resistance	XCIN			–	35	–	MΩ
V _{RAM}	RAM hold voltage			During stop mode	1.8	–	–	V

NOTE:

- V_{CC} = 2.2 V at T_{opr} = -20 to 85°C (N version) / -40 to 85°C (D version), f(XIN) = 5 MHz, unless otherwise specified.

**Table 20.29 Electrical Characteristics (6) [V_{CC} = 2.2 V]
(T_{opr} = -20 to 85°C (N version) / -40 to 85°C (D version), unless otherwise specified.)**

Symbol	Parameter	Condition	Standard			Unit	
			Min.	Typ.	Max.		
I _{CC}	Power supply current (V _{CC} = 2.2 to 2.7 V) Single-chip mode, output pins are open, other pins are V _{SS}	High-speed clock mode	XIN = 5 MHz (square wave) High-speed on-chip oscillator off Low-speed on-chip oscillator on = 125 kHz No division	–	3.5	–	mA
			XIN = 5 MHz (square wave) High-speed on-chip oscillator off Low-speed on-chip oscillator on = 125 kHz Divide-by-8	–	1.5	–	mA
		High-speed on-chip oscillator mode	XIN clock off High-speed on-chip oscillator on f _{OCO} = 5 MHz Low-speed on-chip oscillator on = 125 kHz No division	–	3.5	–	mA
			XIN clock off High-speed on-chip oscillator on f _{OCO} = 5 MHz Low-speed on-chip oscillator on = 125 kHz Divide-by-8	–	1.5	–	mA
		Low-speed on-chip oscillator mode	XIN clock off High-speed on-chip oscillator off Low-speed on-chip oscillator on = 125 kHz Divide-by-8, FMR47 = 1	–	100	230	μA
		Low-speed clock mode	XIN clock off High-speed on-chip oscillator off Low-speed on-chip oscillator off XCIN clock oscillator on = 32 kHz FMR47 = 1	–	100	230	μA
			XIN clock off High-speed on-chip oscillator off Low-speed on-chip oscillator off XCIN clock oscillator on = 32 kHz Program operation on RAM Flash memory off, FMSTP = 1	–	25	–	μA
		Wait mode	XIN clock off High-speed on-chip oscillator off Low-speed on-chip oscillator on = 125 kHz While a WAIT instruction is executed Peripheral clock operation VCA27 = VCA26 = VCA25 = 0 VCA20 = 1	–	22	60	μA
			XIN clock off High-speed on-chip oscillator off Low-speed on-chip oscillator on = 125 kHz While a WAIT instruction is executed Peripheral clock off VCA27 = VCA26 = VCA25 = 0 VCA20 = 1	–	20	55	μA
			XIN clock off High-speed on-chip oscillator off Low-speed on-chip oscillator off XCIN clock oscillator on = 32 kHz (high drive) While a WAIT instruction is executed VCA27 = VCA26 = VCA25 = 0 VCA20 = 1	–	3.0	–	μA
			XIN clock off High-speed on-chip oscillator off Low-speed on-chip oscillator off XCIN clock oscillator on = 32 kHz (low drive) While a WAIT instruction is executed VCA27 = VCA26 = VCA25 = 0 VCA20 = 1	–	1.8	–	μA
			Increase during A/D converter operation	Without sample & hold	–	0.4	–
		With sample & hold	–	0.3	–	mA	
		Stop mode	XIN clock off, T _{opr} = 25°C High-speed on-chip oscillator off Low-speed on-chip oscillator off CM10 = 1 Peripheral clock off VCA27 = VCA26 = VCA25 = 0	–	0.7	3.0	μA
			XIN clock off, T _{opr} = 85°C High-speed on-chip oscillator off Low-speed on-chip oscillator off CM10 = 1 Peripheral clock off VCA27 = VCA26 = VCA25 = 0	–	1.1	–	μA

Timing requirements**(Unless Otherwise Specified: $V_{CC} = 2.2\text{ V}$, $V_{SS} = 0\text{ V}$ at $T_{opr} = 25^\circ\text{C}$) [$V_{CC} = 2.2\text{ V}$]****Table 20.30 XIN Input, XCIN Input**

Symbol	Parameter	Standard		Unit
		Min.	Max.	
$t_{c(XIN)}$	XIN input cycle time	200	–	ns
$t_{WH(XIN)}$	XIN input "H" width	90	–	ns
$t_{WL(XIN)}$	XIN input "L" width	90	–	ns
$t_{c(XCIN)}$	XCIN input cycle time	14	–	μs
$t_{WH(XCIN)}$	XCIN input "H" width	7	–	μs
$t_{WL(XCIN)}$	XCIN input "L" width	7	–	μs

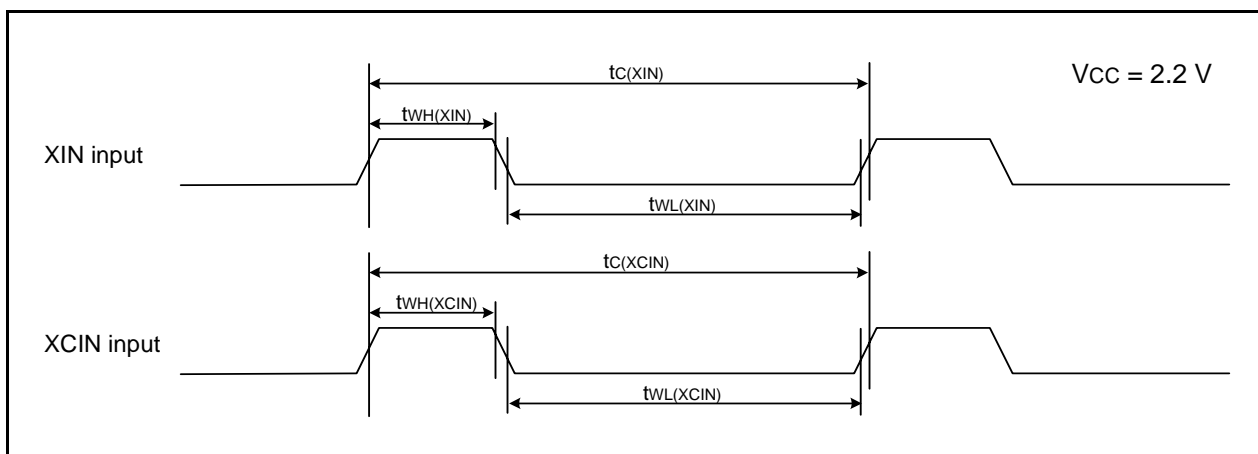
**Figure 20.16 XIN Input and XCIN Input Timing Diagram when $V_{CC} = 2.2\text{ V}$** **Table 20.31 TRAI0 Input**

Symbol	Parameter	Standard		Unit
		Min.	Max.	
$t_{c(TRAI0)}$	TRAI0 input cycle time	500	–	ns
$t_{WH(TRAI0)}$	TRAI0 input "H" width	200	–	ns
$t_{WL(TRAI0)}$	TRAI0 input "L" width	200	–	ns

**Figure 20.17 TRAI0 Input Timing Diagram when $V_{CC} = 2.2\text{ V}$**

Table 20.32 Serial Interface

Symbol	Parameter	Standard		Unit
		Min.	Max.	
$t_{c(CK)}$	CLKi input cycle time	800	–	ns
$t_{w(CKH)}$	CLKi input “H” width	400	–	ns
$t_{w(CKL)}$	CLKi input “L” width	400	–	ns
$t_{d(C-Q)}$	TXDi output delay time	–	200	ns
$t_{h(C-Q)}$	TXDi hold time	0	–	ns
$t_{su(D-C)}$	RXDi input setup time	150	–	ns
$t_{h(C-D)}$	RXDi input hold time	90	–	ns

i = 0 or 1

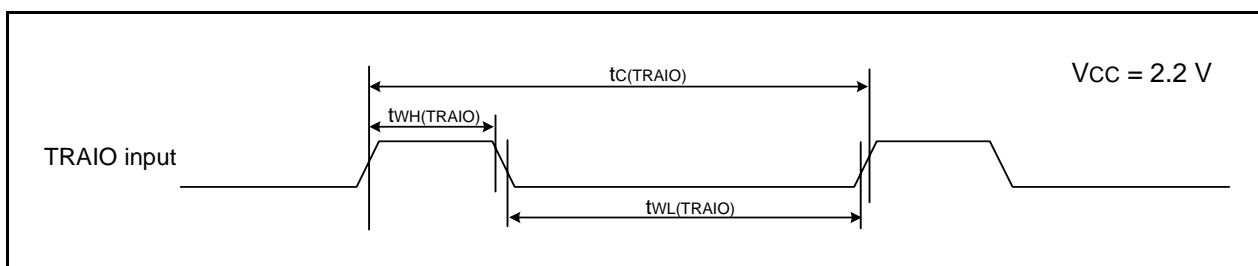
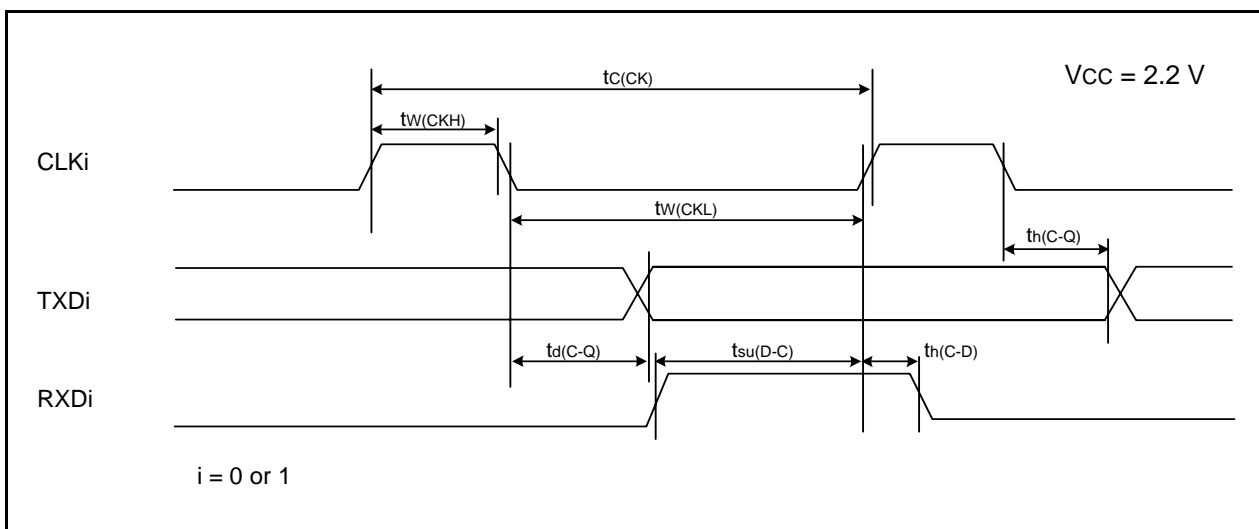

Figure 20.18 Serial Interface Timing Diagram when Vcc = 2.2 V

Table 20.33 External Interrupt \overline{INTi} (i = 0 to 3) Input

Symbol	Parameter	Standard		Unit
		Min.	Max.	
$t_{w(INH)}$	$\overline{INT0}$ input “H” width	1000 ⁽¹⁾	–	ns
$t_{w(INL)}$	$\overline{INT0}$ input “L” width	1000 ⁽²⁾	–	ns

NOTES:

1. When selecting the digital filter by the \overline{INTi} input filter select bit, use an \overline{INTi} input HIGH width of either (1/digital filter clock frequency × 3) or the minimum value of standard, whichever is greater.
2. When selecting the digital filter by the \overline{INTi} input filter select bit, use an \overline{INTi} input LOW width of either (1/digital filter clock frequency × 3) or the minimum value of standard, whichever is greater.

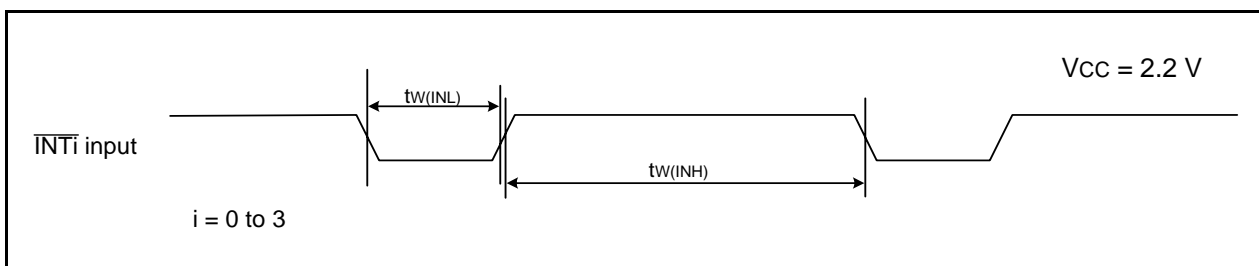

Figure 20.19 External Interrupt \overline{INTi} Input Timing Diagram when Vcc = 2.2 V

21. Usage Notes

21.1 Notes on Clock Generation Circuit

21.1.1 Stop Mode

When entering stop mode, set the FMR01 bit in the FMR0 register to 0 (CPU rewrite mode disabled) and the CM10 bit in the CM1 register to 1 (stop mode). An instruction queue pre-reads 4 bytes from the instruction which sets the CM10 bit to 1 (stop mode) and the program stops.

Insert at least 4 NOP instructions following the JMP.B instruction after the instruction which sets the CM10 bit to 1.

- Program example to enter stop mode

```

BCLR    1,FMR0    ; CPU rewrite mode disabled
BSET    0,PRCR    ; Protect disabled
BSET    0,CM1     ; Stop mode
JMP.B   LABEL_001
LABEL_001 :
NOP
NOP
NOP
NOP

```

21.1.2 Wait Mode

When entering wait mode, set the FMR01 bit in the FMR0 register to 0 (CPU rewrite mode disabled) and execute the WAIT instruction. An instruction queue pre-reads 4 bytes from the WAIT instruction and the program stops. Insert at least 4 NOP instructions after the WAIT instruction.

- Program example to execute the WAIT instruction

```

FSET    I        ; Enable interrupt
BCLR    1,FMR0    ; CPU rewrite mode disabled
WAIT    ; Wait mode
NOP
NOP
NOP
NOP

```

21.1.3 Oscillation Stop Detection Function

Since the oscillation stop detection function cannot be used if the XIN clock frequency is 2 MHz or below, set bits OCD1 to OCD0 to 00b.

21.1.4 Oscillation Circuit Constants

Ask the manufacturer of the oscillator to specify the best oscillation circuit constants for your system.

To use this MCU with supply voltage below $VCC = 2.7$ V, it is recommended to set the CM11 bit in the CM1 register to 1 (on-chip feedback resistor disabled), the CM15 bit to 1 (high drive capacity), and connect the feedback resistor to the chip externally.

21.2 Notes on Interrupts

21.2.1 Reading Address 00000h

Do not read address 00000h by a program. When a maskable interrupt request is acknowledged, the CPU reads interrupt information (interrupt number and interrupt request level) from 00000h in the interrupt sequence. At this time, the acknowledged interrupt IR bit is set to 0.

If address 00000h is read by a program, the IR bit for the interrupt which has the highest priority among the enabled interrupts is set to 0. This may cause the interrupt to be canceled, or an unexpected interrupt to be generated.

21.2.2 SP Setting

Set any value in the SP before an interrupt is acknowledged. The SP is set to 0000h after reset. Therefore, if an interrupt is acknowledged before setting a value in the SP, the program may run out of control.

21.2.3 External Interrupt and Key Input Interrupt

Either “L” level or an “H” level of width shown in the Electrical Characteristics is necessary for the signal input to pins $\overline{\text{INT0}}$ to $\overline{\text{INT3}}$ and pins $\overline{\text{KI0}}$ to $\overline{\text{KI3}}$, regardless of the CPU clock.

For details, refer to **Table 20.21** (VCC = 5V), **Table 20.27** (VCC = 3V), **Table 20.33** (VCC = 2.2V) **External Interrupt INT_i (i = 0 to 3) Input**.

21.2.4 Watchdog Timer Interrupt

Reset the watchdog timer after a watchdog timer interrupt is generated.

21.2.5 Changing Interrupt Sources

The IR bit in the interrupt control register may be set to 1 (interrupt requested) when the interrupt source changes. When using an interrupt, set the IR bit to 0 (no interrupt requested) after changing the interrupt source. In addition, changes of interrupt sources include all factors that change the interrupt sources assigned to individual software interrupt numbers, polarities, and timing. Therefore, if a mode change of a peripheral function involves interrupt sources, edge polarities, and timing, set the IR bit to 0 (no interrupt requested) after the change. Refer to the individual peripheral function for its related interrupts.

Figure 21.1 shows an Example of Procedure for Changing Interrupt Sources.

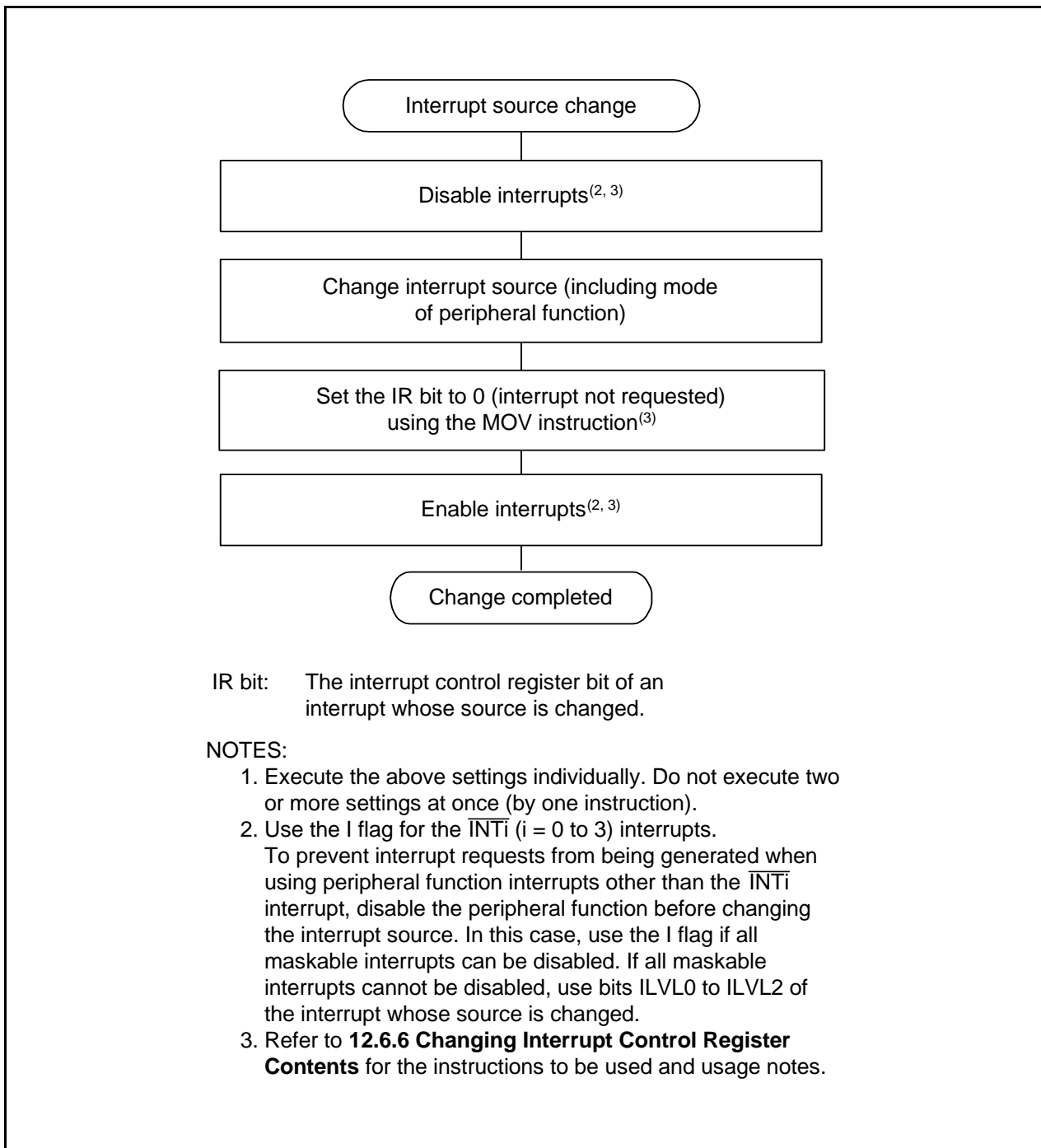

Figure 21.1 Example of Procedure for Changing Interrupt Sources

21.2.6 Changing Interrupt Control Register Contents

- (a) The contents of an interrupt control register can only be changed while no interrupt requests corresponding to that register are generated. If interrupt requests may be generated, disable interrupts before changing the interrupt control register contents.
- (b) When changing the contents of an interrupt control register after disabling interrupts, be careful to choose appropriate instructions.

Changing any bit other than IR bit

If an interrupt request corresponding to a register is generated while executing the instruction, the IR bit may not be set to 1 (interrupt requested), and the interrupt request may be ignored. If this causes a problem, use the following instructions to change the register: AND, OR, BCLR, BSET

Changing IR bit

If the IR bit is set to 0 (interrupt not requested), it may not be set to 1 depending on the instruction used. Therefore, use the MOV instruction to set the IR bit to 1.

- (c) When disabling interrupts using the I flag, set the I flag as shown in the sample programs below. Refer to (b) regarding changing the contents of interrupt control registers by the sample programs.

Sample programs 1 to 3 are for preventing the I flag from being set to 1 (interrupts enabled) before the interrupt control register is changed for reasons of the internal bus or the instruction queue buffer.

Example 1: Use NOP instructions to prevent I flag from being set to 1 before interrupt control register is changed

```
INT_SWITCH1:
  FCLR   I           ; Disable interrupts
  AND.B  #00H,0056H ; Set TRAIC register to 00h
  NOP                    ;
  NOP                    ;
  FSET   I           ; Enable interrupts
```

Example 2: Use dummy read to delay FSET instruction

```
INT_SWITCH2:
  FCLR   I           ; Disable interrupts
  AND.B  #00H,0056H ; Set TRAIC register to 00h
  MOV.W  MEM,R0      ; Dummy read
  FSET   I           ; Enable interrupts
```

Example 3: Use POPC instruction to change I flag

```
INT_SWITCH3:
  PUSHC  FLG
  FCLR   I           ; Disable interrupts
  AND.B  #00H,0056H ; Set TRAIC register to 00h
  POPC   FLG        ; Enable interrupts
```

21.3 Notes on Timers

21.3.1 Notes on Timer RA

- Timer RA stops counting after a reset. Set the values in the timer RA and timer RA prescalers before the count starts.
- Even if the prescaler and timer RA are read out in 16-bit units, these registers are read 1 byte at a time by the MCU. Consequently, the timer value may be updated during the period when these two registers are being read.
- In pulse period measurement mode, bits TEDGF and TUNDF in the TRACR register can be set to 0 by writing 0 to these bits by a program. However, these bits remain unchanged if 1 is written. When using the READ-MODIFY-WRITE instruction for the TRACR register, the TEDGF or TUNDF bit may be set to 0 although these bits are set to 1 while the instruction is being executed. In this case, write 1 to the TEDGF or TUNDF bit which is not supposed to be set to 0 with the MOV instruction.
- When changing to pulse period measurement mode from another mode, the contents of bits TEDGF and TUNDF are undefined. Write 0 to bits TEDGF and TUNDF before the count starts.
- The TEDGF bit may be set to 1 by the first timer RA prescaler underflow generated after the count starts.
- When using the pulse period measurement mode, leave two or more periods of the timer RA prescaler immediately after the count starts, then set the TEDGF bit to 0.
- The TCSTF bit retains 0 (count stops) for 0 to 1 cycle of the count source after setting the TSTART bit to 1 (count starts) while the count is stopped.

During this time, do not access registers associated with timer RA⁽¹⁾ other than the TCSTF bit. Timer RA starts counting at the first valid edge of the count source after The TCSTF bit is set to 1 (during count).

The TCSTF bit remains 1 for 0 to 1 cycle of the count source after setting the TSTART bit to 0 (count stops) while the count is in progress.

During this time, do not access registers associated with timer RA⁽¹⁾ other than the TCSTF bit. Timer RA counting is stopped when the TCSTF bit is set to 0.

NOTE:

1. Registers associated with timer RA: TRACR, TRAIOC, TRAMR, TRAPRE, and TRA.

21.3.2 Notes on Timer RB

- Timer RB stops counting after a reset. Set the values in the timer RB and timer RB prescalers before the count starts.
- Even if the prescaler and timer RB is read out in 16-bit units, these registers are read 1 byte at a time by the MCU. Consequently, the timer value may be updated during the period when these two registers are being read.
- In programmable one-shot generation mode and programmable wait one-shot generation mode, when setting the TSTART bit in the TRBCR register to 0 (count stops) or setting the TOSSP bit in the TRBOCR register to 1 (one-shot stops), the timer reloads the value of reload register and stops. Therefore, in programmable one-shot generation mode and programmable wait one-shot generation mode, read the timer count value before the timer stops.
- The TCSTF bit remains 0 (count stops) for 1 to 2 cycles of the count source after setting the TSTART bit to 1 (count starts) while the count is stopped.

During this time, do not access registers associated with timer RB⁽¹⁾ other than the TCSTF bit.

The TCSTF bit remains 1 for 1 to 2 cycles of the count source after setting the TSTART bit to 0 (count stops) while the count is in progress.

During this time, do not access registers associated with timer RB⁽¹⁾ other than the TCSTF bit.

Timer RB counting is stopped when the TCSTF bit is set to 0.

NOTE:

1. Registers associated with timer RB: TRBCR, TRBOCR, TRBMR, TRBPRES, TRBSC, and TRRBPR.
- If the TSTOP bit in the TRBCR register is set to 1 during timer operation, timer RB stops immediately.
 - If 1 is written to the TOSST or TOSSP bit in the TRBOCR register, the value of the TOSSTF bit changes after one or two cycles of the count source have elapsed. If the TOSSP bit is written to 1 during the period between when the TOSST bit is written to 1 and when the TOSSTF bit is set to 1, the TOSSTF bit may be set to either 0 or 1 depending on the content state. Likewise, if the TOSST bit is written to 1 during the period between when the TOSSP bit is written to 1 and when the TOSSTF bit is set to 0, the TOSSTF bit may be set to either 0 or 1.

21.3.3 Notes on Timer RD

21.3.3.1 TRDSTR Register

- Set the TRDSTR register using the MOV instruction.
- When the CSEL_i (i = 0 to 1) is set to 0 (the count stops after the count is cleared at compare match of registers TRD_i and TRDGRA_i), the count does not stop and the TSTART_i bit remains unchanged even if 0 (count stops) is written to the TSTART_i bit.
- Therefore, set the TSTART_i bit to 0 to change other bits without changing the TSTART_i bit when the CSEL_i bit is set to 0.
- To stop counting by a program, set the TSTART_i bit after setting the CSEL_i bit to 1. Although the CSEL_i bit is set to 1 and the TSTART_i bit is set to 0 at the same time (with 1 instruction), the count cannot be stopped.
- Table 21.1 lists the TRDIO_{ji} (j = A, B, C, or D) Pin Output Level when Count Stops to use the TRDIO_{ji} (j = A, B, C, or D) pin with the timer RD output.

Table 21.1 TRDIO_{ji} (j = A, B, C, or D) Pin Output Level when Count Stops

Count Stop	TRDIO _{ji} Pin Output when Count Stops
When the CSEL _i bit is set to 1, set the TSTART _i bit to 0 and the count stops.	Hold the output level immediately before the count stops.
When the CSEL _i bit is set to 0, the count stops after the count is cleared at compare match of registers TRD _i and TRDGRA _i .	Hold the output level after output changes by compare match.

21.3.3.2 TRD_i Register (i = 0 or 1)

- When writing the value to the TRD_i register by a program while the TSTART_i bit in the TRDSTR register is set to 1 (count starts), avoid overlapping with the timing for setting the TRD_i register to 0000h, and then write. If the timing for setting the TRD_i register to 0000h overlaps with the timing for writing the value to the TRD_i register, the value is not written and the TRD_i register is set to 0000h. These precautions are applicable when selecting the following by bits CCLR2 to CCLR0 in the TRDCR_i register.
 - 001b (Clear by the TRD_i register at compare match with the TRDGRA_i register.)
 - 010b (Clear by the TRD_i register at compare match with the TRDGRB_i register.)
 - 011b (Synchronous clear)
 - 101b (Clear by the TRD_i register at compare match with the TRDGRC_i register.)
 - 110b (Clear by the TRD_i register at compare match with the TRDGRD_i register.)
- When writing the value to the TRD_i register and continuously reading the same register, the value before writing may be read. In this case, execute the JMP.B instruction between the writing and reading.

```

Program example      MOV.W      #XXXXh, TRD0      ;Writing
                    JMP.B      L1                ;JMP.B
                    L1:      MOV.W      TRD0,DATA    ;Reading
  
```

21.3.3.3 TRDSR_i Register (i = 0 or 1)

When writing the value to the TRDSR_i register and continuously reading the same register, the value before writing may be read. In this case, execute the JMP.B instruction between the writing and reading.

```

Program example      MOV.B      #XXh, TRDSR0    ;Writing
                    JMP.B      L1                ;JMP.B
                    L1:      MOV.B      TRDSR0,DATA ;Reading
  
```

21.3.3.4 Count Source Switch

- Switch the count source after the count stops.

Change procedure

- (1) Set the TSTART_i (i = 0 or 1) bit in the TRDSTR register to 0 (count stops).
- (2) Change bits TCK2 to TCK0 in the TRDCR_i register.

- When changing the count source from fOCO40M to another source and stopping fOCO40M, wait 2 cycles of f1 or more after setting the clock switch, and then stop fOCO40M.

Change procedure

- (1) Set the TSTART_i (i = 0 or 1) bit in the TRDSTR register to 0 (count stops).
- (2) Change bits TCK2 to TCK0 in the TRDCR_i register.
- (3) Wait 2 or more cycles of f1.
- (4) Set the FRA00 bit in the FRA0 register to 0 (high-speed on-chip oscillator stops).

21.3.3.5 Input Capture Function

- Set the pulse width of the input capture signal to 3 or more cycles of the timer RD operation clock (refer to **Table 14.11 Timer RD Operation Clocks**).
- The value in the TRD_i register is transferred to the TRDGR_{ji} register 2 to 3 cycles of the timer RD operation clock after the input capture signal is applied to the TRDIO_{ji} pin (i = 0 or 1, j = either A, B, C, or D) (no digital filter).

21.3.3.6 Reset Synchronous PWM Mode

- When reset synchronous PWM mode is used for motor control, make sure OLS0 = OLS1.
- Set to reset synchronous PWM mode by the following procedure:

Change procedure

- (1) Set the TSTART0 bit in the TRDSTR register to 0 (count stops).
- (2) Set bits CMD1 to CMD0 in the TRDFCR register to 00b (timer mode, PWM mode, and PWM3 mode).
- (3) Set bits CMD1 to CMD0 to 01b (reset synchronous PWM mode).
- (4) Set the other registers associated with timer RD again.

21.3.3.7 Complementary PWM Mode

- When complementary PWM mode is used for motor control, make sure OLS0 = OLS1.
- Change bits CMD1 to CMD0 in the TRDFCR register in the following procedure.

Change procedure: When setting to complementary PWM mode (including re-set), or changing the transfer timing from the buffer register to the general register in complementary PWM mode.

- (1) Set both the TSTART0 and TSTART1 bits in the TRDSTR register to 0 (count stops).
- (2) Set bits CMD1 to CMD0 in the TRDFCR register to 00b (timer mode, PWM mode, and PWM3 mode).
- (3) Set bits CMD1 to CMD0 to 10b or 11b (complementary PWM mode).
- (4) Set the registers associated with other timer RD again.

Change procedure: When stopping complementary PWM mode

- (1) Set both the TSTART0 and TSTART1 bits in the TRDSTR register to 0 (count stops).
- (2) Set bits CMD1 to CMD0 to 00b (timer mode, PWM mode, and PWM3 mode).

- Do not write to TRDGRA0, TRDGRB0, TRDGRA1, or TRDGRB1 register during operation. When changing the PWM waveform, transfer the values written to registers TRDGRD0, TRDGRC1, and TRDGRD1 to registers TRDGRB0, TRDGRA1, and TRDGRB1 using the buffer operation. However, to write data to the TRDGRD0, TRDGRC1, or TRDGRD1 register, set bits BFD0, BFC1, and BFD1 to 0 (general register). After this, bits BFD0, BFC1, and BFD1 may be set to 1 (buffer register). The PWM period cannot be changed.

- If the value in the TRDGRA0 register is assumed to be m , the TRD0 register counts $m-1$, m , $m+1$, m , $m-1$, in that order, when changing from increment to decrement operation.

When changing from m to $m+1$, the IMFA bit is set to 1. Also, bits CMD1 to CMD0 in the TRDFCR register are set to 11b (complementary PWM mode, buffer data transferred at compare match between registers TRD0 and TRDGRA0), the content in the buffer registers (TRDGRD0, TRDGRC1, and TRDGRD1) is transferred to the general registers (TRDGRB0, TRDGRA1, and TRDGRB1).

During $m+1$, m , and $m-1$ operation, the IMFA bit remains unchanged and data are not transferred to registers such as the TRDGRA0 register.

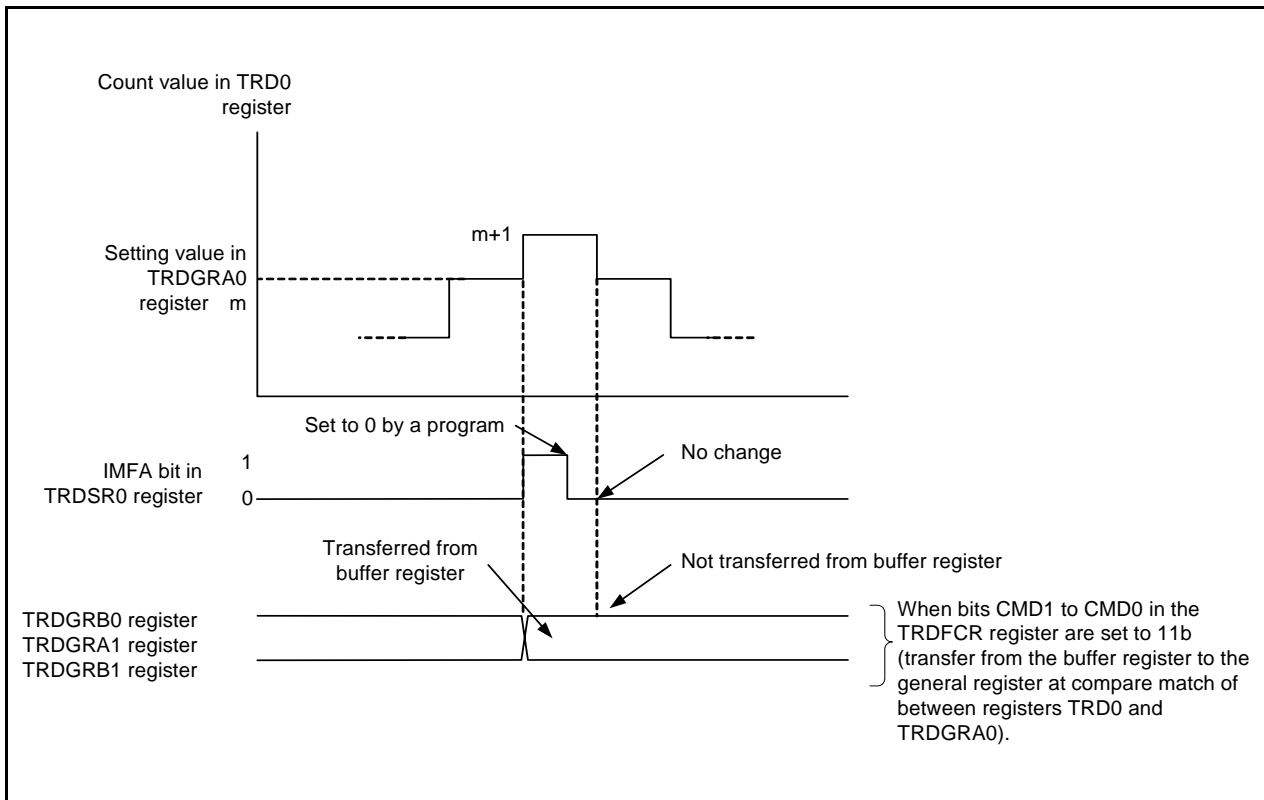

Figure 21.2 Operation at Compare Match between Registers TRD0 and TRDGRA0 in Complementary PWM Mode

- The TRD1 register counts 1, 0, FFFFh, 0, 1, in that order, when changing from decrement to increment operation.

The UDF bit is set to 1 when changing between 1, 0, and FFFFh operation. Also, when bits CMD1 to CMD0 in the TRDFCR register are set to 10b (complementary PWM mode, buffer data transferred at underflow in the TRD1 register), the content in the buffer registers (TRDGRD0, TRDGRC1, and TRDGRD1) is transferred to the general registers (TRDGRB0, TRDGRA1, and TRDGRB1). During FFFFh, 0, 1 operation, data are not transferred to registers such as the TRDGRB0 register. Also, at this time, the OVF bit remains unchanged.

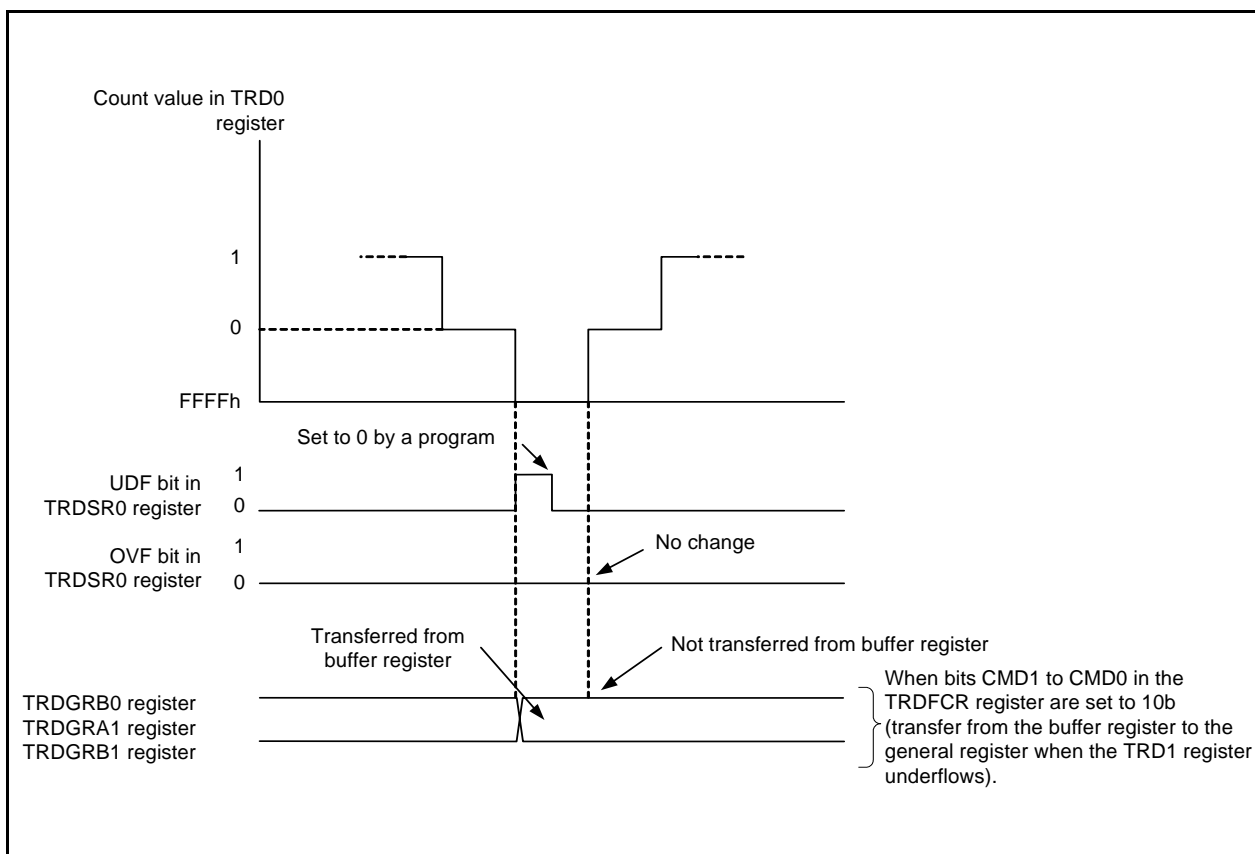

Figure 21.3 Operation when TRD1 Register Underflows in Complementary PWM Mode

- Select with bits CMD1 to CMD0 the timing of data transfer from the buffer register to the general register. However, transfer takes place with the following timing in spite of the value of bits CMD1 to CMD0 in the following cases:

Value in buffer register \geq value in TRDGRA0 register:

Transfer take place at underflow of the TRD1 register.

After this, when the buffer register is set to 0001h or above and a smaller value than the value of the TRDGRA0 register, and the TRD1 register underflows for the first time after setting, the value is transferred to the general register. After that, the value is transferred with the timing selected by bits CMD1 to CMD0.

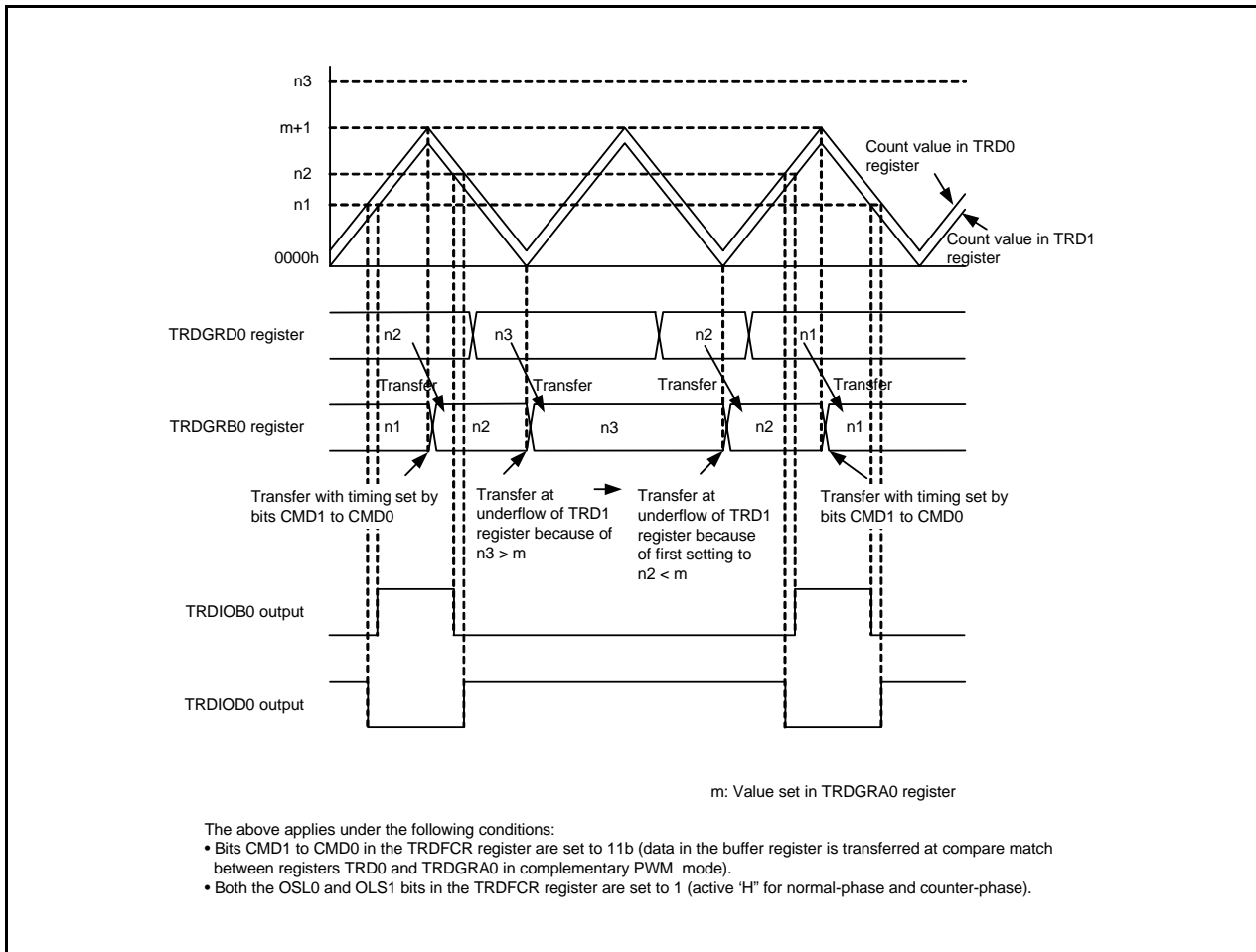

Figure 21.4 Operation when Value in Buffer Register \geq Value in TRDGRA0 Register in Complementary PWM Mode

When the value in the buffer register is set to 0000h:

Transfer takes place at compare match between registers TRD0 and TRDGRA0.

After this, when the buffer register is set to 0001h or above and a smaller value than the value of the TRDGRA0 register, and a compare match occurs between registers TRD0 and TRDGRA0 for the first time after setting, the value is transferred to the general register. After that, the value is transferred with the timing selected by bits CMD1 to CMD0.

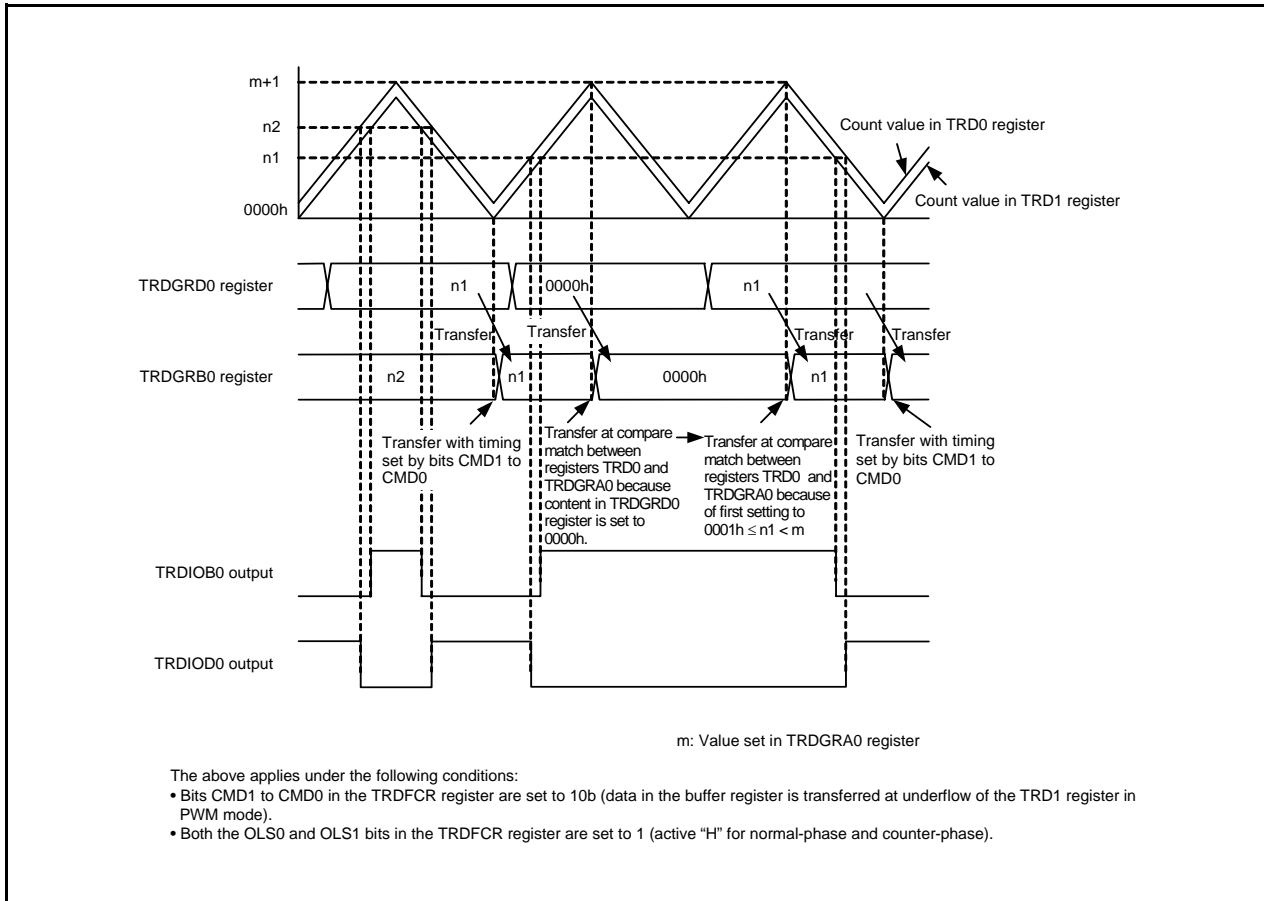

Figure 21.5 Operation when Value in Buffer Register Is Set to 0000h in Complementary PWM Mode

21.3.3.8 Count Source fOCO40M

- The count source fOCO40M can be used with supply voltage $V_{CC} = 3.0$ to 5.5 V. For supply voltage other than that, do not set bits TCK2 to TCK0 in registers TRDCR0 and TRDCR to 110b (select fOCO40M as the count source).

21.3.4 Notes on Timer RE

21.3.4.1 Starting and Stopping Count

Timer RE has the TSTART bit for instructing the count to start or stop, and the TCSTF bit, which indicates count start or stop. Bits TSTART and TCSTF are in the TREC1 register.

Timer RE starts counting and the TCSTF bit is set to 1 (count starts) when the TSTART bit is set to 1 (count starts). It takes up to 2 cycles of the count source until the TCSTF bit is set to 1 after setting the TSTART bit to 1. During this time, do not access registers associated with timer RE⁽¹⁾ other than the TCSTF bit.

Also, timer RE stops counting when setting the TSTART bit to 0 (count stops) and the TCSTF bit is set to 0 (count stops). It takes the time for up to 2 cycles of the count source until the TCSTF bit is set to 0 after setting the TSTART bit to 0. During this time, do not access registers associated with timer RE other than the TCSTF bit.

NOTE:

1. Registers associated with timer RE: TRESEC, TREMIN, TREHR, TREWK, TREC1, TREC2, and TREC3.

21.3.4.2 Register Setting

Write to the following registers or bits when timer RE is stopped.

- Registers TRESEC, TREMIN, TREHR, TREWK, and TREC2
- Bits H12_H24, PM, and INT in TREC1 register
- Bits RCS0 to RCS3 in TREC3 register

Timer RE is stopped when bits TSTART and TCSTF in the TREC1 register are set to 0 (timer RE stopped).

Also, set all above-mentioned registers and bits (immediately before timer RE count starts) before setting the TREC2 register.

Figure 21.6 shows a Setting Example in Real-Time Clock Mode.

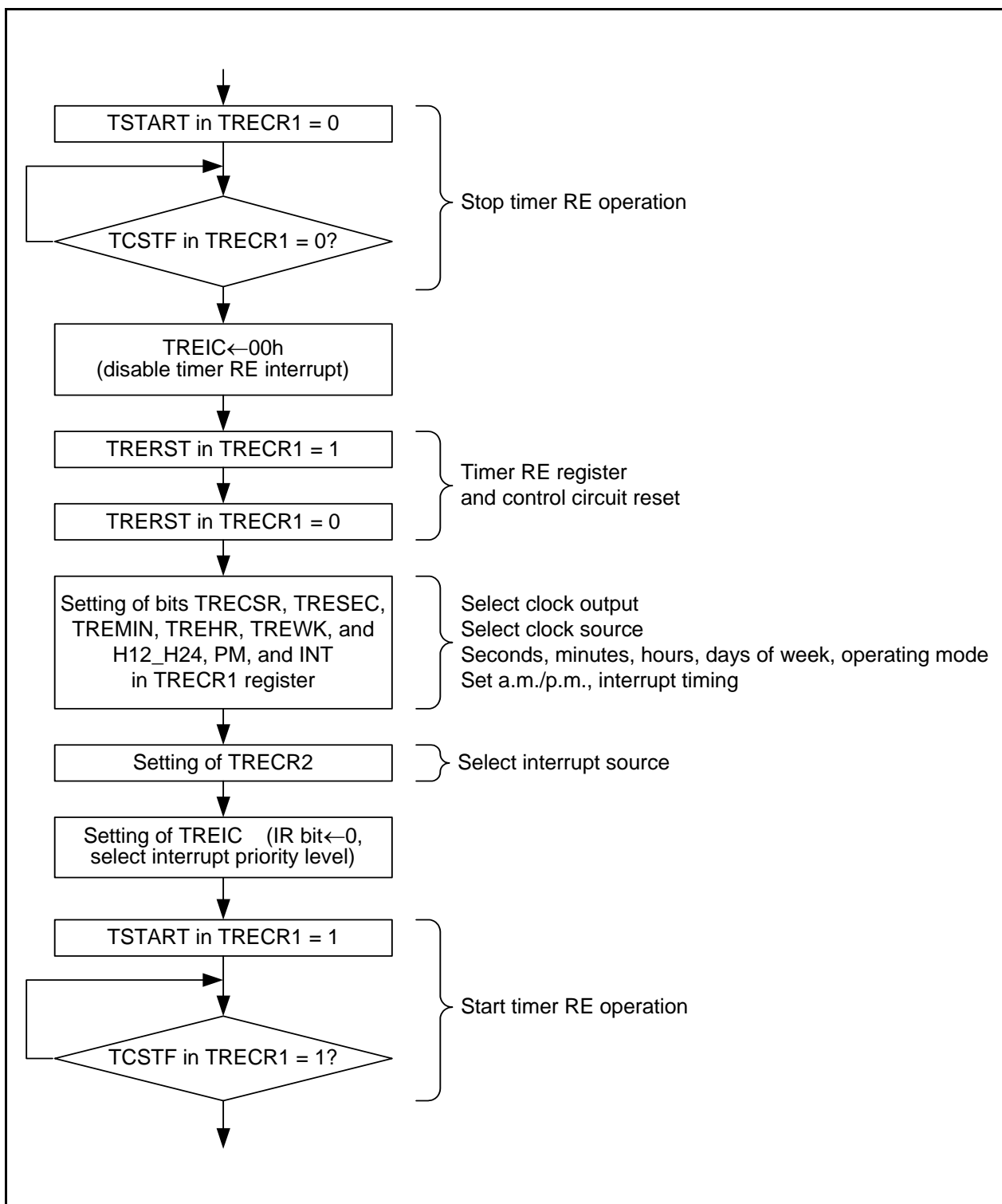

Figure 21.6 Setting Example in Real-Time Clock Mode

21.3.4.3 Time Reading Procedure of Real-Time Clock Mode

In real-time clock mode, read registers TRESEC, TREMIN, TREHR, and TREWK when time data is updated and read the PM bit in the TRECR1 register when the BSY bit is set to 0 (not while data is updated).

Also, when reading several registers, an incorrect time will be read if data is updated before another register is read after reading any register.

In order to prevent this, use the reading procedure shown below.

- Using an interrupt

Read necessary contents of registers TRESEC, TREMIN, TREHR, and TREWK and the PM bit in the TRECR1 register in the timer RE interrupt routine.

- Monitoring with a program 1

Monitor the IR bit in the TREIC register with a program and read necessary contents of registers TRESEC, TREMIN, TREHR, and TREWK and the PM bit in the TRECR1 register after the IR bit in the TREIC register is set to 1 (timer RE interrupt request generated).

- Monitoring with a program 2

- (1) Monitor the BSY bit.

- (2) Monitor until the BSY bit is set to 0 after the BSY bit is set to 1 (approximately 62.5 ms while the BSY bit is set to 1).

- (3) Read necessary contents of registers TRESEC, TREMIN, TREHR, and TREWK and the PM bit in the TRECR1 register after the BSY bit is set to 0.

- Using read results if they are the same value twice

- (1) Read necessary contents of registers TRESEC, TREMIN, TREHR, and TREWK and the PM bit in the TRECR1 register.

- (2) Read the same register as (1) and compare the contents.

- (3) Recognize as the correct value if the contents match. If the contents do not match, repeat until the read contents match with the previous contents.

Also, when reading several registers, read them as continuously as possible.

21.4 Notes on Serial Interface

- When reading data from the UiRB (i = 0 or 1) register either in the clock synchronous serial I/O mode or in the clock asynchronous serial I/O mode. Ensure the data is read in 16-bit units. When the high-order byte of the UiRB register is read, bits PER and FER in the UiRB register and the RI bit in the UiC1 register are set to 0.

Example (when reading receive buffer register):

```
MOV.W    00A6H,R0    ; Read the UORB register
```

- When writing data to the UiTB register in the clock asynchronous serial I/O mode with 9-bit transfer data length, write data to the high-order byte first then the low-order byte, in 8-bit units.

Example (when reading transmit buffer register):

```
MOV.B    #XXH,00A3H  ; Write the high-order byte of U0TB register  
MOV.B    #XXH,00A2H  ; Write the low-order byte of U0TB register
```

21.5 Notes on Clock Synchronous Serial Interface

21.5.1 Notes on Clock Synchronous Serial I/O with Chip Select

Set the IICSEL bit in the PMR register to 0 (select clock synchronous serial I/O with chip select function) to use the clock synchronous serial I/O with chip select function.

21.5.1.1 Accessing Registers Associated with Clock Synchronous Serial I/O with Chip Select

After waiting three instructions or more after writing to the registers associated with clock synchronous serial I/O with chip select (00B8h to 00BFh) or four cycles or more after writing to them, read the registers.

- An example of waiting three instructions or more

```

Program example      MOV.B    #00h,00BBh    ; Set the SSER register to 00h.
                    NOP
                    NOP
                    NOP
                    MOV.B    00BBh,R0L
  
```

- An example of waiting four cycles or more

```

Program example      BCLR    4,00BBh    ; Disable transmission
                    JMP.B    NEXT
NEXT:
                    BSET    3,00BBh    ; Enable reception
  
```

21.5.2 Notes on I²C bus Interface

Set the IICSEL bit in the PMR register to 1 (select I²C bus interface function) to use the I²C bus interface.

21.5.2.1 Accessing of Registers Associated with I²C bus Interface

Wait for three instructions or more or four cycles or more after writing to the same register among the registers associated with the I²C bus Interface (00B8h to 00BFh) before reading it.

- An example of waiting three instructions or more

```

Program example      MOV.B    #00h,00BBh    ; Set ICIER register to 00h
                    NOP
                    NOP
                    NOP
                    MOV.B    00BBh,R0L
  
```

- An example of waiting four cycles or more

```

Program example      BCLR    6,00BBh    ; Disable transmit end interrupt request
                    JMP.B    NEXT
NEXT:
                    BSET    7,00BBh    ; Enable transmit data empty interrupt request
  
```

21.6 Notes on Hardware LIN

For the time-out processing of the header and response fields, use another timer to measure the duration of time with a Synch Break detection interrupt as the starting point.

21.7 Notes on A/D Converter

- Write to each bit (other than bit 6) in the ADCON0 register, each bit in the ADCON1 register, or the SMP bit in the ADCON2 register when A/D conversion is stopped (before a trigger occurs).
When the VCUT bit in the ADCON1 register is changed from 0 (VREF not connected) to 1 (VREF connected), wait for at least 1 μ s before starting the A/D conversion.
- After changing the A/D operating mode, select an analog input pin again.
- When using the one-shot mode, ensure that A/D conversion is completed before reading the AD register. The IR bit in the ADIC register or the ADST bit in the ADCON0 register can be used to determine whether A/D conversion is completed.
- When using the repeat mode, use the undivided XIN clock as the CPU clock. Do not select the fOCO-F for the ϕ AD.
- If the ADST bit in the ADCON0 register is set to 0 (A/D conversion stops) by a program and A/D conversion is forcibly terminated during an A/D conversion operation, the conversion result of the A/D converter will be undefined. If the ADST bit is set to 0 by a program, do not use the value of the AD register.
- Connect 0.1 μ F capacitor between the P4_2/VREF pin and AVSS pin.

21.8 Notes on Flash Memory

21.8.1 CPU Rewrite Mode

21.8.1.1 Operating Speed

Before entering CPU rewrite mode (EW0 mode), select 5 MHz or below for the CPU clock using the CM06 bit in the CM0 register and bits CM16 to CM17 in the CM1 register. This does not apply to EW1 mode.

21.8.1.2 Prohibited Instructions

The following instructions cannot be used in EW0 mode because they reference data in the flash memory: UND, INTO, and BRK.

21.8.1.3 Interrupts

Table 21.2 lists the EW0 Mode Interrupts and Table 21.3 lists the EW1 Mode Interrupts.

Table 21.2 EW0 Mode Interrupts

Mode	Status	When Maskable Interrupt Request is Acknowledged	When Watchdog Timer, Oscillation Stop Detection, Voltage Monitor 1, or Voltage Monitor 2 Interrupt Request is Acknowledged
EW0	During auto-erasure	Any interrupt can be used by allocating a vector in RAM	Once an interrupt request is acknowledged, auto-programming or auto-erasure is forcibly stopped immediately and the flash memory is reset. Interrupt handling starts after the fixed period and the flash memory restarts. Since the block during auto-erasure or the address during auto-programming is forcibly stopped, the normal value may not be read. Execute auto-erasure again and ensure it completes normally. Since the watchdog timer does not stop during the command operation, interrupt requests may be generated. Reset the watchdog timer regularly.
	Auto-programming		

NOTES:

1. Do not use the address match interrupt while a command is being executed because the vector of the address match interrupt is allocated in ROM.
2. Do not use a non-maskable interrupt while block 0 is being automatically erased because the fixed vector is allocated in block 0.

Table 21.3 EW1 Mode Interrupts

Mode	Status	When Maskable Interrupt Request is Acknowledged	When Watchdog Timer, Oscillation Stop Detection, Voltage Monitor 1, or Voltage Monitor 2 Interrupt Request is Acknowledged
EW1	During auto-erasure (erase-suspend function enabled)	Auto-erasure is suspended after $t_d(SR-SUS)$ and interrupt handling is executed. Auto-erasure can be restarted by setting the FMR41 bit in the FMR4 register to 0 (erase restart) after interrupt handling completes.	Once an interrupt request is acknowledged, auto-programming or auto-erasure is forcibly stopped immediately and the flash memory is reset. Interrupt handling starts after the fixed period and the flash memory restarts. Since the block during auto-erasure or the address during auto-programming is forcibly stopped, the normal value may not be read. Execute auto-erasure again and ensure it completes normally. Since the watchdog timer does not stop during the command operation, interrupt requests may be generated. Reset the watchdog timer regularly using the erase-suspend function.
	During auto-erasure (erase-suspend function disabled)	Auto-erasure has priority and the interrupt request acknowledgement is put on standby. Interrupt handling is executed after auto-erasure completes.	
	During auto-programming (program suspend function enabled)	Auto-programming is suspended after $t_d(SR-SUS)$ and interrupt handling is executed. Auto-programming can be restarted by setting the FMR42 bit in the FMR4 register to 0 (program restart) after interrupt handling completes.	
	During auto-programming (program suspend function disabled)	Auto-programming has priority and the interrupt request acknowledgement is put on standby. Interrupt handling is executed after auto-programming completes.	

NOTES:

1. Do not use the address match interrupt while a command is executing because the vector of the address match interrupt is allocated in ROM.
2. Do not use a non-maskable interrupt while block 0 is being automatically erased because the fixed vector is allocated in block 0.

21.8.1.4 How to Access

Write 0 before writing 1 when setting the FMR01, FMR02, or FMR11 bit to 1. Do not generate an interrupt between writing 0 and 1.

21.8.1.5 Rewriting User ROM Area

In EW0 Mode, if the supply voltage drops while rewriting any block in which a rewrite control program is stored, it may not be possible to rewrite the flash memory because the rewrite control program cannot be rewritten correctly. In this case, use standard serial I/O mode.

21.8.1.6 Program

Do not write additions to the already programmed address.

21.8.1.7 Entering Stop Mode or Wait Mode

Do not enter stop mode or wait mode during erase-suspend.

21.8.1.8 Program and Erase Voltage for Flash Memory

To perform programming and erasure, use $V_{CC} = 2.7\text{ V}$ to 5.5 V as the supply voltage. Do not perform programming and erasure at less than 2.7 V .

21.9 Notes on Noise

21.9.1 Inserting a Bypass Capacitor between VCC and VSS Pins as a Countermeasure against Noise and Latch-up

Connect a bypass capacitor (at least 0.1 μ F) using the shortest and thickest wire possible.

21.9.2 Countermeasures against Noise Error of Port Control Registers

During rigorous noise testing or the like, external noise (mainly power supply system noise) can exceed the capacity of the MCU's internal noise control circuitry. In such cases the contents of the port related registers may be changed.

As a firmware countermeasure, it is recommended that the port registers, port direction registers, and pull-up control registers be reset periodically. However, examine the control processing fully before introducing the reset routine as conflicts may be created between the reset routine and interrupt routines.

22. Notes on On-Chip Debugger

When using the on-chip debugger to develop and debug programs for the R8C/24 Group and R8C/25 Group take note of the following.

- (1) Do not access the related UART1 registers.
- (2) Some of the user flash memory and RAM areas are used by the on-ship debugger. These areas cannot be accessed by the user.
Refer to the on-chip debugger manual for which areas are used.
- (3) Do not set the address match interrupt (registers AIER, RMAD0, and RMAD1 and fixed vector tables) in a user system.
- (4) Do not use the BRK instruction in a user system.
- (5) Debugging is available under the condition of supply voltage $VCC = 2.7$ to 5.5 V. Debugging with the on-chip debugger under less than 2.7 V is not allowed.

Connecting and using the on-chip debugger has some special restrictions. Refer to the on-chip debugger manual for details.

Appendix 1. Package Dimensions

Diagrams showing the latest package dimensions and mounting information are available in the “Packages” section of the Renesas Technology website.

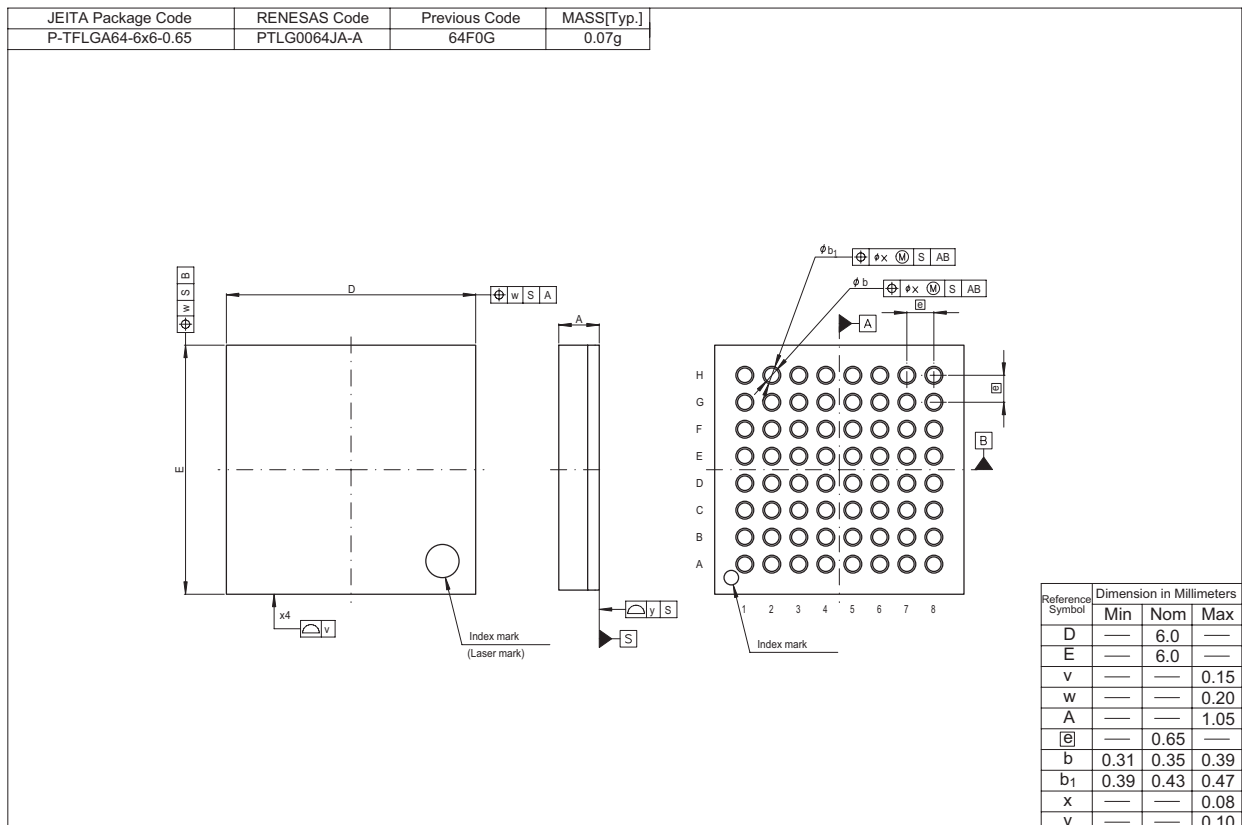
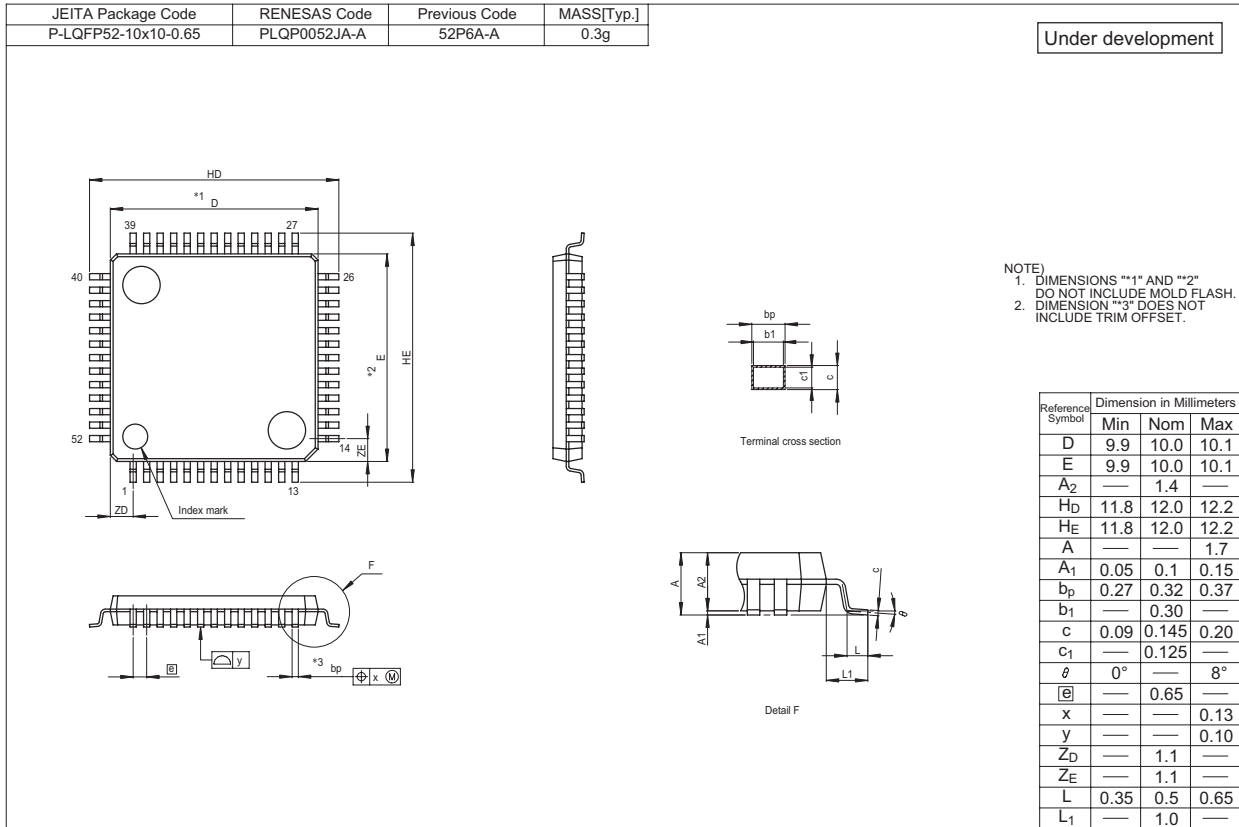

Appendix 2. Connection Examples between Serial Writer and On-Chip Debugging Emulator

Appendix Figure 2.1 shows a Connection Example with M16C Flash Starter (M3A-0806) and Appendix Figure 2.2 shows a Connection Example with E8 Emulator (R0E000080KCE00).

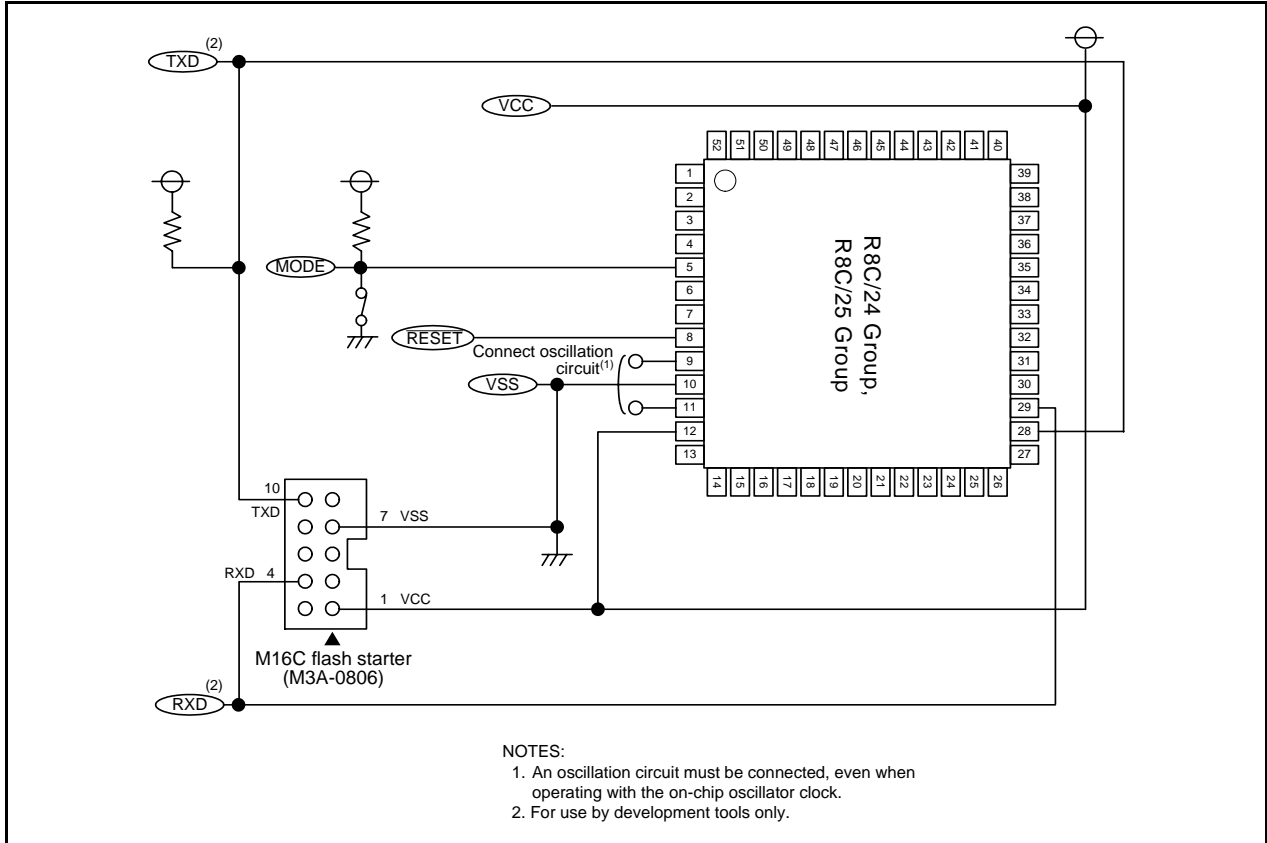

Appendix Figure 2.1 Connection Example with M16C Flash Starter (M3A-0806)

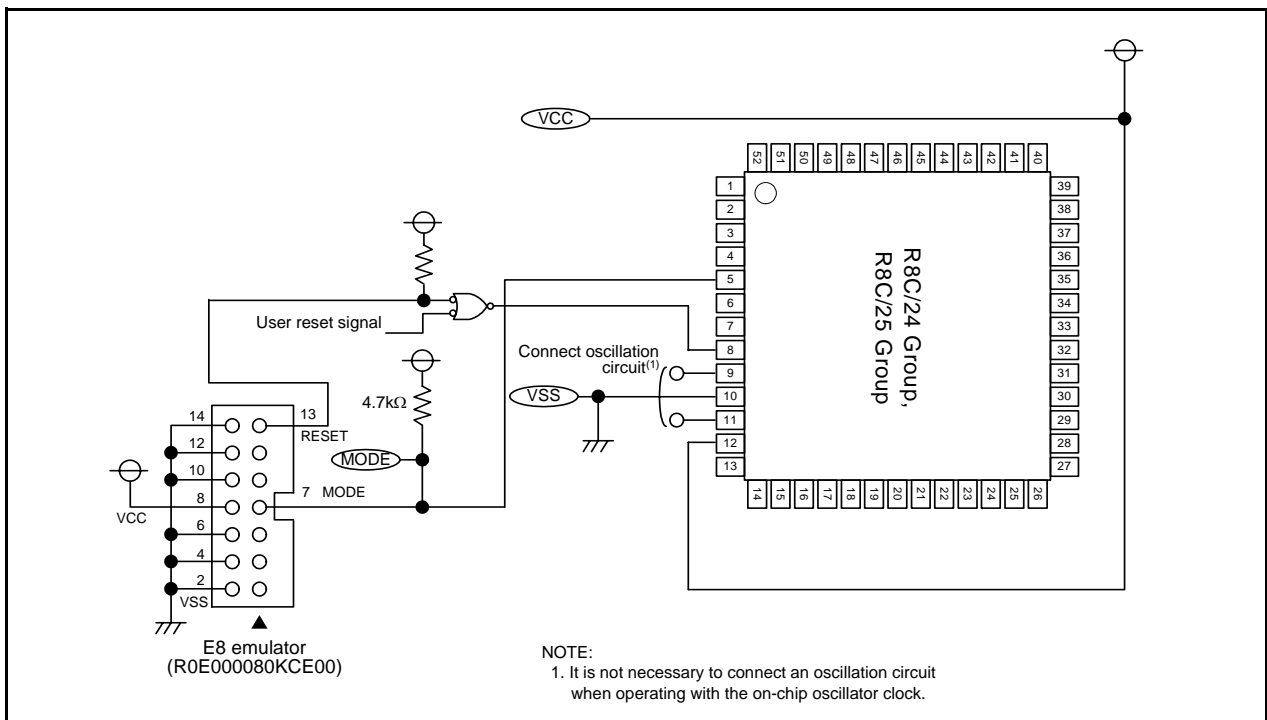

Appendix Figure 2.2 Connection Example with E8 Emulator (R0E000080KCE00)

Appendix 3. Example of Oscillation Evaluation Circuit

Appendix Figure 3.1 shows an Example of Oscillation Evaluation Circuit.

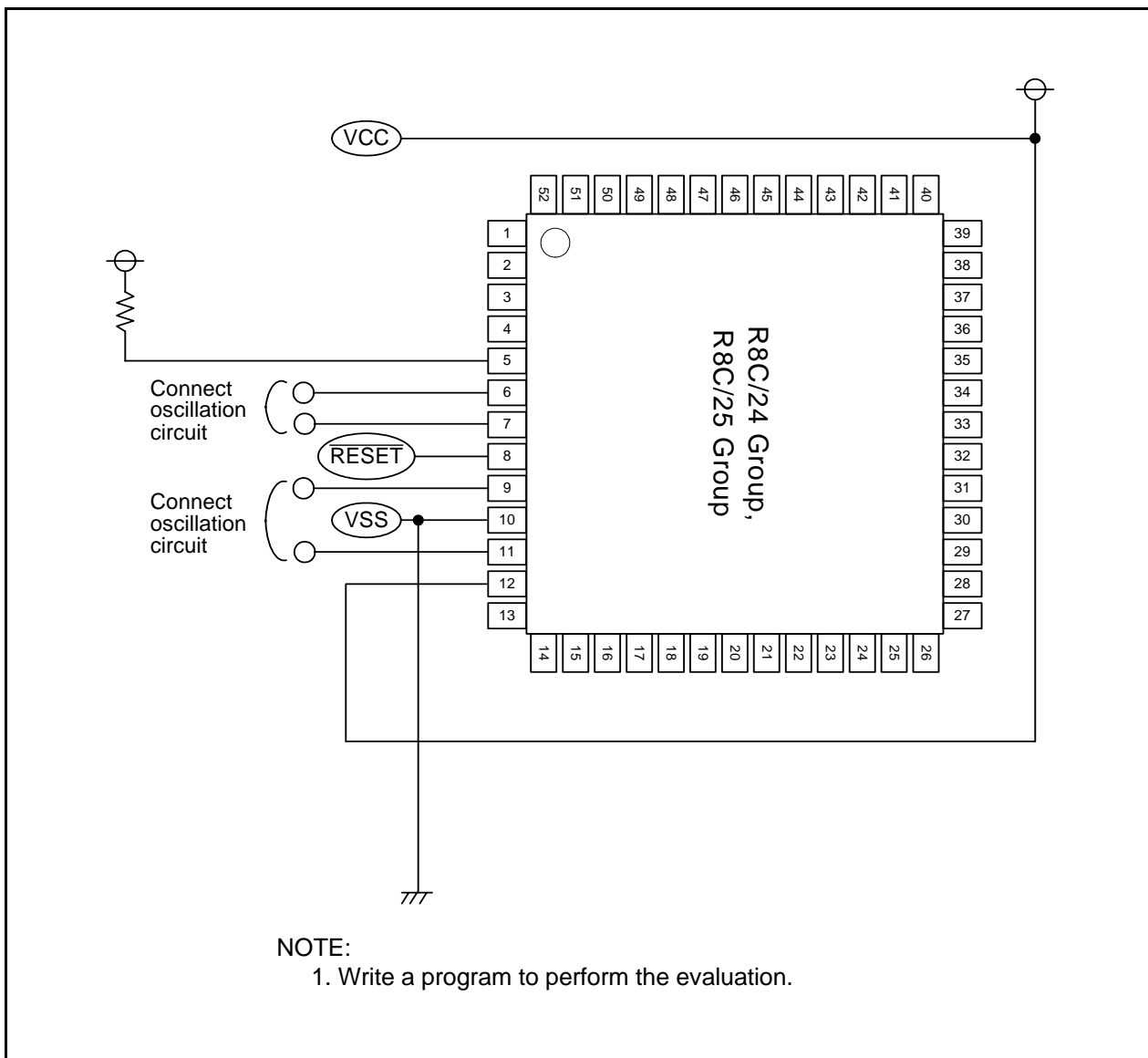

Appendix Figure 3.1 Example of Oscillation Evaluation Circuit

Index

[A]		PUR0	57
AD	383	PUR1	57
ADCON0	382	[R]	
ADCON1	383	RMAD0	120
ADCON2	383	RMAD1	120
ADIC	105	[S]	
AIER	120	S0RIC	105
[C]		S0TIC	105
CM0	75	S1RIC	105
CM1	76	S1TIC	105
CPSRF	80	SAR	340
CSPR	128	SSCRH	305
[F]		SSCRL	306
FMR0	403	SSER	308
FMR1	404	SSMR	307
FMR4	405	SSMR2	310
FRA0	78	SSRDR	311
FRA1	78	SSSR	309
FRA2	79	SSTDR	311
FRA4	79	SSUIC	106
FRA6	79	[T]	
[I]		TRA	135
ICCR1	335	TRACR	134
ICCR2	336	TRAIC	105
ICDRR	341	TRAIOC	134, 136, 139, 141, 143, 146
ICDRS	341	TRAMR	135
ICDRT	340	TRAPRE	135
ICIER	338	TRBCR	150
ICMR	337	TRBIC	105
ICSR	339	TRBIOC	151, 153, 157, 159, 164
IICIC	106	TRBMR	151
INT0IC	107	TRBOCR	150
INT1IC	107	TRBPR	152
INT2IC	107	TRBPPE	152
INT3IC	107	TRBSC	152
INTEN	114	TRD0	188, 204, 218, 229, 241, 255
INTF	115	TRD0IC	106
[K]		TRD1	188, 204, 218, 241
KIEN	118	TRD1IC	106
KUPIC	105	TRDCR0	184, 199, 215, 227, 238, 253
[L]		TRDCR1	184, 199, 215, 238
LINCR	367	TRDDF0	183
LINST	368	TRDDF1	183
[O]		TRDFCR	182, 196, 213, 225, 236, 250
OCD	77	TRDGRAi (i = 0 to 1)	189, 204, 219, 230, 241, 256
OFS	27, 127, 398	TRDGRBi (i = 0 to 1)	189, 204, 219, 230, 241, 256
[P]		TRDGRCi (i = 0 to 1)	189, 204, 219, 230, 241, 256
P2DRR	58	TRDGRDi (i = 0 to 1)	189, 204, 219, 230, 241, 256
PDi (i = 0 to 4 and 6)	56	TRDIER0	188, 203, 217, 229, 240, 255
Pi (i = 0 to 4 and 6)	56	TRDIER1	188, 203, 217, 229, 240, 255
PM0	71	TRDIORA0	185, 200
PM1	71	TRDIORA1	185, 200
PMR	58, 290, 311, 341	TRDIORC0	186, 201
PRCR	99	TRDIORC1	186, 201
		TRDMR	180, 194, 211, 224, 235, 249
		TRDOCR	198, 215, 252
		TRDOER1	197, 214, 226, 237, 251
		TRDOER2	197, 214, 226, 237, 251
		TRDPMR	181, 195, 212
		TRDPOCR0	218
		TRDPOCR1	218

TRDSR0	187, 202, 216, 228, 239, 254
TRDSR1	187, 202, 216, 228, 239, 254
TRDSTR	180, 194, 211, 224, 234, 248
TRECR1	272, 279
TRECR2	273, 279
TRECSR	274, 280
TREHR	271
TREIC	105
TREMIN	270, 278
TRESEC	270, 278
TREWK	271

[U]

U0BRG	288
U0C0	289
U0C1	290
U0MR	288
U0RB	287
U0TB	287
U1BRG	288
U1C0	289
U1C1	290
U1MR	288
U1RB	287
U1SR	290
U1TB	287

[V]

VCA1	36
VCA2	36, 80
VW0C	37
VW1C	38
VW2C	39

[W]

WDC	127
WDTR	128
WDTS	128

REVISION HISTORY

R8C/24 Group, R8C/25 Group Hardware Manual

Rev.	Date	Description	
		Page	Summary
0.10	Jul 27, 2005	–	First Edition issued
0.20	Jan 16, 2006	all pages	<ul style="list-style-type: none"> • “Preliminary” deleted • Symbol name “TRDMDR” → “TRDMR”, “SSUAIC” → “SSUIC”, “IIC2AIC” → “IICIC”, and “TSTOP0, TSTOP1” → “CSEL0, CSEL1” revised • Pin name “TCLK” → “TRDCLK” revised • Bit name “TPSC0 to TPSC2” → “TCK0 to TCK2”, “TRD0 count stop bit” → “TRD0 count operation select bit”, and “TRD1 count stop bit” → “TRD1 count operation select bit” revised <p>2 Table 1.1 Functions and Specifications for R8C/24 Group revised</p> <p>3 Table 1.2 Functions and Specifications for R8C/25 Group revised</p> <p>4 Figure 1.1 Block Diagram; “Peripheral Functions” added, “System Clock Generation” → “System Clock Generator” revised</p> <p>5 Table 1.3 Product Information for R8C/24 Group revised</p> <p>6 Table 1.4 Product Information of R8C/25 Group revised</p> <p>7 Figure 1.4 Pin Assignment (Top View); “VSS” → “VSS/AVSS” and “VCC” → “VCC/AVCC” revised</p> <p>8 Table 1.5 Pin Functions; “Analog power supply input” added, “Reference voltage input” revised</p> <p>9 Table 1.6 Pin Name Information by Pin Number “VSS” → “VSS/AVSS” and “VCC” → “VCC/AVCC” revised</p> <p>10 Figure 2.1 CPU Registers; “Reserved Area” → “Reserved Bit” revised</p> <p>12 2.8.10 Reserved Area; “Reserved Area” → “Reserved bit” revised</p> <p>13 Figure 3.1 Memory Map of R8C/24 Group; “Program area” → “program ROM” revised</p> <p>14 3.2 R8C/25 Group, Figure 3.2 Memory Map of R8C/25 Group; “Data area” → “data flash”, “Program area” → “program ROM” revised</p> <p>15 Table 4.1 SFR Information(1); 0012h: “X0h” → “00h” 0016h: “X0h” → “00h” 0024h: “TBD” → “When shipping” NOTES 3 and 4 revised</p> <p>24 Figure 5.4 OFS Register; NOTE1 revised and NOTE3 added</p> <p>25 5.1.1 When Power Supply is Stable (2) revised 5.1.2 Power On (4) revised</p> <p>26 Figure 5.5 Example of Hardware Reset Circuit and Operation and Figure 5.6 Example of Hardware Reset Circuit (Usage Example of External Supply Voltage Detection Circuit) and Operation revised</p>

REVISION HISTORY

R8C/24 Group, R8C/25 Group Hardware Manual

Rev.	Date	Description	
		Page	Summary
0.20	Jan 16, 2006	27	5.2 Power-On Reset Function “When a capacitor is ... or more.” added Figure 5.7 Example of Power-On Reset Circuit and Operation revised
		28	5.4 Voltage Monitor 1 Reset; “When ... VCC pin drops the Vdet1 ...” → “When ... VCC pin reaches to the Vdet1 ...” revised
		30 to 67	“6. Programmable I/O Ports” → “6. Voltage Detection Circuit” and “7. Voltage Detection Circuit” → “7. Programmable I/O Ports” revised
		33	Figure 6.5 Registers VCA1 and VCA2; VCA2 register revised
		34	Figure 6.6 VW0C Register revised
		46	Figure 7.2 Configuration of Programmable I/O Ports (2) revised
		47	Figure 7.3 Configuration of Programmable I/O Ports (3) revised
		49	Figure 7.5 Configuration of Programmable I/O Ports (5) revised
		50	Figure 7.6 Configuration of Programmable I/O Ports (6) revised
		51	Figure 7.7 Configuration of Programmable I/O Ports (7) revised
		56 to 66	7.4 Port setting added; Table 7.4 Port P0_0/AN7 to Table 7.47 Port P6_7/ $\overline{\text{INT3}}$ /RXD1 added
		67	Table 7.48 Unassigned Pin Handling revised
		69	9. Bus revised; “However, only following SFRs are ... accessed at a time.” added Table 9.2 Bus Cycles by Access Space of the R8C/25 Group added, Table 9.3 Access Unit and Bus Operations; “SFR” → “SFR, data flash”, “ROM/RAM” → “ROM (program ROM), RAM” revised
		71	Figure 10.1 Clock Generation Circuit revised
		72	Figure 10.2 CM0 Register revised
		73	Figure 10.3 CM1 Register revised
		75	Figure 10.5 Registers FRA0 and FRA1; FRA0 register revised
		77	Figure 10.8 VCA2 Register added
		78	Figure 10.9 Examples of XIN Clock Connection Circuit revised
		79	10.2.2 High-Speed On-Chip Oscillator Clock; “To use the high-speed on-chip ... or more).” added
80	10.3 XCIN Clock “To input an external clock ... pin open.” added		
81	10.4.2 CPU Clock “Use the XCIN clock while ... stabilizes.” added 10.4.3 Peripheral Function Clock (f1, f2, f4, f8, f32, fC4, and fC32); “Use fC4 and fC32 while the XCIN clock oscillation stabilizes.” added 10.4.5 fOCO40M; “fOCO40M can be ... supply voltage VCC = 3.0 to 5.5 V.” added 10.4.8 fOCO128 added		
82	Table 10.2 Settings and Modes of Clock Associated Bits revised		

REVISION HISTORY

R8C/24 Group, R8C/25 Group Hardware Manual

Rev.	Date	Description	
		Page	Summary
0.20	Jan 16, 2006	83	10.5.1.2 Low-Speed Clock Mode; “In this mode, stopping the XIN clock ... the VCA20 bit.” added
		84	10.5.1.4 Low-Speed On-Chip Oscillator Mode; “In this mode, stopping the XIN clock ... the VCA20 bit.” added
		88	Figure 10.11 Handling Procedure of Internal Power Low Consumption Enabled by VCA20 bit added
		89	Figure 10.12 State Transition in Power Control Mode revised
		92	10.6.1 How to Use Oscillation Stop Detection Function; “• This function cannot be... is 2 MHz or below. ...” → “• This function cannot be... is below 2 MHz. ...” revised
		107	10.7.1 Stop Mode and 10.7.2 Wait Mode → 10.7.1 Stop Mode and Wait Mode revised
		114	10.7.3 Oscillation Stop Detection Function; “Since ... is 2 MHz or below, ...” → “Since ... is below 2 MHz. ...” revised “To use this MCU with supply voltage ... to the chip externally.” added
		119	10.7.4 fOCO40M added
		121	Figure 12.11 Interrupt Priority Level Judgement Circuit; NOTE2 deleted
		126	Figure 12.18 Registers AIER and RMAD0 to RMAD1; AIER and RMAD0 to RMAD1 register revised
		127	12.6.7 Entering Wait Mode after Oscillation Stop Detection Interrupt is Detected added
		135	Figure 13.2 Registers OFS and WDC; OFS register NOTE1 revised and NOTE3 added, and WDC register NOTE1 deleted
		142	Table 14.1 Functional Comparison of Timers; Input Pin: Timer RD “TRDCLK” added
		144	Figure 14.1 Block Diagram of Timer RA revised
		146	Table 14.3 Pulse Output Mode Specifications revised
		147	Table 14.6 Pulse Period Measurement Mode Specifications revised
		149	Figure 14.11 Operating Example of Pulse Period Measurement Mode revised
		158	Figure 14.12 Block Diagram of Timer RB revised
		162	Figure 14.13 Registers TRBCR and TRBOCR; TRBOCR register revised
		165	Figure 14.15 Registers TRBPRES, TRBSC, and TRBPR; TRBPR register revised
	Figure 14.20 TRBIOC Register in Programmable One-Shot Generation Mode		
	Figure 14.23 Registers TRBIOC and TRBMR in Programmable One-Shot Generation Mode; TRBIOC register NOTE2 revised		
	Figure 14.25 Registers TRBIOC and TRBMR in Programmable Wait One-Shot Generation Mode; TRBIOC register NOTE2 revised		
	-Output compare function; “(Pin output can be changed at detection)” added		

Rev.	Date	Description	
		Page	Summary
0.20	Jan 16, 2006	166 to 168	Tables 14.12 Pin Functions TRDIOA0/TRDCLK(P2_0) Tables 14.13 Pin Functions TRDIOB0(P2_1) Tables 14.14 Pin Functions TRDIOC0(P2_2) Tables 14.15 Pin Functions TRDIOD0(P2_3) Tables 14.16 Pin Functions TRDIOA1(P2_4) Tables 14.17 Pin Functions TRDIOB1(P2_5) Tables 14.18 Pin Functions TRDIOC1(P2_6) Tables 14.19 Pin Functions TRDIOD1(P2_7) Tables 14.20 Pin Functions INT0(P4_5) added
		170	14.3.1 Mode Selection deleted
		170	Table 14.21 Count Source Selection revised 14.3.1 Count Sources; “TRDCRi register to ...” → “TRDCRi register (i = 0 or 1) to ...” revised
		171	Figure 14.29 Buffer Operation in Input Capture Function revised
		172	Figure 14.30 Buffer Operation in Output Capture Function revised 14.3.2 Buffer Operation; “input capture and ...” → “timer mode (input capture and ...” “the IOC2 to IOC0 bits in ...” → “the IOC2 bit in ...” “the IOA2 to IOA0 bits in ...” → “the IOA2 bit in ...” “the IOD2 to IOD0 bits in ...” → “the IOD2 bit in ...” “the IOB2 to IOC0 bits in ...” → “the IOB2 bit in ...” revised “Bits IMFC and IMFD in the TRDSRi...input capture function.” added
		173	14.3.3 Synchronous Operation; “For the synchronous operation, ... register = 110b.” deleted
		174	14.3.4 Pulse Output Forced Cutoff; “P2D” → “PD2”, “P4D” → “PD4”, and “P4_5” → “PD4_5”, revised “According to the selection ... details of interrupts.” added
		176	14.3.5 Input Capture Function; “The TRDGRA0 register can also ... trigger input.” added Figure 14.33 Block Diagram of Input Capture Function revised
		177	Table 14.23 Specifications of Input Capture Function revised
		178	Figure 14.34 Registers TRDSTR and TRDMR in Input Capture Function revised
		179	Figure 14.35 TRDPMR Register in Input Capture Function revised
		180	Figure 14.36 TRDFCR Register in Input Capture Function revised
		183	Figure 14.39 Registers TRDIORA0 to TRDIORA1 in Input Capture Function revised
		184	Figure 14.40 Registers TRDIORC0 to TRDIORC1 in Input Capture Function revised
		185	Figure 14.41 Registers TRDSR0 to TRDSR1 in Input Capture Function revised
		187	Table 14.25 Input Pin Function in Input Capture Function deleted
		189	14.3.5.1 Digital Filter; “TRDDF register ...” → “TRDDFi register ...” revised

REVISION HISTORY

R8C/24 Group, R8C/25 Group Hardware Manual

Rev.	Date	Description	
		Page	Summary
0.20	Jan 16, 2006	192	Figure 14.48 Registers TRDSTR and TRDMR in Output Compare Function revised
		193	Figure 14.49 TRDPMR Register in Output Compare Function revised
		194	Figure 14.50 TRDFCR Register in Output Compare Function revised
		195	Figure 14.51 Registers TRDOER1 to TRDOER2 in Output Compare Function; TRDOER2 register: NOTE1 added
		198	Figure 14.54 Registers TRDIORA0 to TRDIORA1 in Output Compare Function revised
		199	Figure 14.55 Registers TRDIORC0 to TRDIORC1 in Output Compare Function revised
		200	Figure 14.56 Registers TRDSR0 to TRDSR1 in Output Compare Function revised
		209	Figure 14.64 Registers TRDSTR and TRDMR in PWM Mode revised
		210	Figure 14.65 TRDPMR Register in PWM Mode revised
		211	Figure 14.66 TRDFCR Register in PWM Mode revised
		212	Figure 14.67 Registers TRDOER1 to TRDOER2 in PWM Mode; TRDOER2 register: NOTE1 added
		214	Figure 14.69 Registers TRDSR0 to TRDSR1 in PWM Mode revised
		222	Figure 14.77 Registers TRDSTR to TRDMR in Reset Synchronous PWM Mode revised
		223	Figure 14.78 TRDFCR Register in Reset Synchronous PWM Mode revised
		224	Figure 14.79 Registers TRDOER1 to TRDOER2 in Reset Synchronous PWM Mode; TRDOER2 register: NOTE1 added
		226	Figure 14.81 Registers TRDSR0 to TRDSR1 in Reset Synchronous PWM Mode revised
		232	Figure 14.87 TRDSTR Register in Complementary PWM Mode revised
		233	Figure 14.88 TRDMR Register in Complementary PWM Mode revised
		234	Figure 14.89 TRDFCR Register in Complementary PWM Mode revised
		235	Figure 14.90 Registers TRDOER1 to TRDOER2 in Complementary PWM Mode; TRDOER2 register: NOTE1 added
237	Figure 14.92 Registers TRDSR0 to TRDSR1 in Complementary PWM Mode revised		
244	Figure 14.98 Block Diagram of PWM3 Mode revised		
245	Table 14.33 Specifications of PWM3 Mode revised		
246	Figure 14.99 TRDSTR Register in PWM3 Mode revised		
247	Figure 14.100 TRDMR Register in PWM3 Mode revised		
248	Figure 14.101 TRDFCR Register in PWM3 Mode revised		

REVISION HISTORY

R8C/24 Group, R8C/25 Group Hardware Manual

Rev.	Date	Description	
		Page	Summary
0.20	Jan 16, 2006	249	Figure 14.102 Registers TRDOER1 to TRDOER2 in PWM3 Mode; TRDOER2 register: NOTE1 added
		251	Figure 14.104 TRDCR0 Register in PWM3 Mode NOTE1 deleted
		252	Figure 14.105 TRDSR0 Register in PWM3 Mode revised
		253	Figure 14.106 TRDIER0 Register in PWM3 Mode revised
		255	Table 14.34 TRDGRji Register Functions in PWM3 Mode revised
		256	Figure 14.109 Operating Example of PWM3 Mode revised
		259	14.3.12.1 TRDSTR Register (i = 0 or 1) added
		260	14.3.12.4 "Count Clock Source Switch" → "Count Source Switch" revised
		264	14.3.12.9 Count Source fOCO40M added
		275	Table 14.39 Output Compare Mode Specifications revised
		281	Figure 14.132 Setting Example in Real-Time Clock Mode revised
		285	Figure 15.3 Registers U0TB to U1TB and U0RB to U1RB revised
		286	Figure 15.4 Registers U0BRG to U1BRG and U0MR to U1MR; U0BRG to U1BRG register revised
		287	Figure 15.5 Registers U0C0 to U1C0 NOTE1 added
		295	Table 15.5 Registers Used and Settings for UART Mode; UiBRG: "-" → "0 to 7" revised
		300	Table 16.1 Mode Selections revised
		358	Figure 16.46 Example of Register Setting in Master Transmit Mode (Clock Synchronous Serial Mode); "• Set the IICSEL bit in the PMR register to 1" added
		377	Table 18.1 Performance of A/D converter revised
		378	Figure 18.1 Block Diagram of A/D Converter; "VSS" → "AVSS" and "Vref" → "Vcom" revised
		387 to 389	18.4 A/D Conversion Cycles to 18.6 Inflow Current Bypass Circuit added
		390	18.7 Notes on A/D Converter "• Connect 0.1μF capacitor ... VSS pin." → "• Connect 0.1μF capacitor ... AVSS pin." revised
		391	Table 19.1 Flash Memory Version Performance; • Program and Erase Endurance:(Program area) → (Program ROM), (Data area) → (Data flash) revised • NOTE3 added
		392	19.2 Memory Map; "The user ROM ... area ... Block A and B." → "The user ROM ... area (program ROM) ... Block A and B (data flash)." revised Figure 19.1 Flash Memory Block Diagram for R8C/24 Group revised
393	Figure 19.2 Flash Memory Block Diagram for R8C/25 Group revised		
395	Figure 19.4 OFS Register; NOTE1 revised and NOTE3 added		
398	19.4.2.4 FMSTP Bit revised		

REVISION HISTORY

R8C/24 Group, R8C/25 Group Hardware Manual

Rev.	Date	Description	
		Page	Summary
0.20	Jan 16, 2006	399	19.4.2.16 FMR47 Bit revised
		402	Figure 19.7 FMR4 Register NOTE4 revised
		405	Figure 19.11 Process to Reduce Power Consumption in High-Speed On-Chip Oscillator Mode, Low-Speed On-Chip Oscillator Mode (XIN Clock Stops) and Low-Speed Clock Mode (XIN Clock Stops) revised
		408	19.4.3.5 Block Erase; "The block erase command cannot be ... program-suspend." added
		409	Figure 19.14 Block Erase Command (When Using Erase-Suspend Function) revised
		412	Figure 19.15 Full Status Check and Handling Procedure for Individual Errors revised
		414	Figure 19.16 Pin Connections for Standard Serial I/O Mode revised
		419	19.7.1.9 Program and Erase Voltage for Flash Memory added
		420	Table 20.1 Absolute Maximum Ratings; "Vcc" → "Vcc/AVcc" revised
			Table 20.2 Recommended Operating Conditions revised
		421	Table 20.3 A/D Converter Characteristics revised
		422	Table 20.4 Flash Memory (Program ROM) Electrical Characteristics revised
		423	Table 20.5 Flash Memory (Data flash Block A, Block B) Electrical revised
		424	Table 20.6 Voltage Detection 0 Circuit Electrical Characteristics revised Table 20.7 Voltage Detection 1 Circuit Electrical Characteristics revised Table 20.8 Voltage Detection 2 Circuit Electrical Characteristics revised
		425	Table 20.9 Reset Circuit Electrical Characteristics (When Using Voltage Monitor 0 Reset) NOTE2 revised
		426	Table 20.11 High-speed On-Chip Oscillator Circuit Electrical Characteristics revised Table 20.12 Low-speed On-Chip Oscillator Circuit Electrical Characteristics revised Table 20.13 Power Supply Circuit Timing Characteristics revised
		427	Table 20.14 Timing Requirements of Clock Synchronous Serial I/O with Chip Select revised
		431	Table 20.15 Timing Requirements of I ² C bus Interface NOTE1 revised
		432	Table 20.16 Electrical Characteristics (1) [Vcc = 5 V] revised
		433	Table 20.17 Electrical Characteristics (2) [Vcc = 5 V] revised
		434	Table 20.18 XIN Input, XCIN Input revised
		435	Table 20.20 Serial Interface revised
		436	Table 20.22 Electrical Characteristics (3) [Vcc = 3 V] revised
		437	Table 20.23 Electrical Characteristics (4) [Vcc = 3 V] revised
		438	Table 20.24 XIN Input, XCIN Input revised
		439	Table 20.26 Serial Interface revised
440	Table 20.28 Electrical Characteristics (5) [Vcc = 2.2 V] revised		

REVISION HISTORY

R8C/24 Group, R8C/25 Group Hardware Manual

Rev.	Date	Description	
		Page	Summary
0.20	Jan 16, 2006	441	Table 20.29 Electrical Characteristics (6) [Vcc = 2.2 V] revised
		442	Table 20.30 XIN Input, XCIN Input revised
			Table 20.31 TRAI0 Input, INT1 Input revised
		443	Table 20.32 Serial Interface revised
			Table 20.33 External Interrupt $\overline{\text{INT}}_i$ (i = 0, 2, 3) Input
		444	21.1.1 Stop Mode and 21.1.2 Wait Mode → 21.1.1 Stop Mode and Wait Mode revised
			21.1.3 Oscillation Stop Detection Function; “Since ... is 2 MHz or below, ...” → “Since ... is below 2 MHz. ...” revised “To use this MCU with supply voltage ... to the chip externally.” added
			21.1.4 fOCO40M added
		447	21.2.7 Entering Wait Mode after Oscillation Stop Detection Interrupt is Detected added
		462	21.7 Notes on A/D Converter • Connect 0.1μF capacitor ... VSS pin.” → • Connect 0.1μF capacitor ... AVSS pin.” revised
		465	21.8.1.9 Program and Erase Voltage for Flash Memory added
		467	22. Notes for On-Chip Debugger; (1) and (6) added, “(2) Do not use addresses ... addresses.” deleted
		468	Appendix 1. Package Dimensions; “TBD” → “PLQP0052JA-A (52P6A-A)” added
469	Appendix Figure 2.1 Connection Example with M16C Flash Starter (M3A-0806) revised Appendix Figure 2.2 Connection Example with E8 Emulator (R0E000080KCE00) revised		
470	Appendix Figure 3.1 Example of Oscillation Evaluation Circuit revised		
1.00	May 31, 2006	all pages	“Under development” deleted
		3	Table 1.2 Functions and Specifications for R8C/25 Group revised
		4	Figure 1.1 Block Diagram; “System clock generator” → “System clock generation circuit” revised
		5 to 6	Table 1.3 Product Information for R8C/24 Group and Table 1.4 Product Information for R8C/25 Group; A part of (D) mark is deleted.
		9	Table 1.6 Pin Name Information by Pin Number NOTE1 added
		15	Table 4.1 SFR Information(1); 001Ch: “00h” → “00h, 10000000b” revised 0029h: High-Speed On-Chip Oscillator Control Register 4 FRA4 When shipping added 002Bh: High-Speed On-Chip Oscillator Control Register 6 FRA6 When shipping added NOTE6 added
		19	Table 4.5 SFR Information(5); 0118h: Timer RE Second Data Register / Counter Data Register, 0119h: Timer RE Minute Data Register / Compare Data Register register name revised

REVISION HISTORY

R8C/24 Group, R8C/25 Group Hardware Manual

Rev.	Date	Description	
		Page	Summary
1.00	May 31, 2006	20	Table 4.6 SFR Information(6); 0143h: "11000000b" → "11100000b" revised
		24	Figure 5.4 OFS Register NOTE2 revised
		25	5.1.1 When Power Supply is Stable (2) revised 5.1.2 Power On (4) revised
		26	Figure 5.5 Example of Hardware Reset Circuit and Operation and Figure 5.6 Example of Hardware Reset Circuit (Usage Example of External Supply Voltage Detection Circuit) and Operation revised
		27	Figure 5.7 Example of Power-On Reset Circuit and Operation revised
		28	5.3 Voltage Monitor 0 Reset revised
		33	Figure 6.5 Registers VCA1 and VCA2; VCA2 register NOTE6 revised
		45 to 51	Figures 7.1 to .7.7 Configuration of Programmable I/O Ports NOTE1 added
		53	Figure 7.9 PDi (i = 0 to 4 and 6) Registers NOTE3 added
		54	Figure 7.11 Registers PUR0 and PUR1; After Reset revised
		62	Table 7.31 Port P3_4/SDA/SCS revised
		70	Table 10.1 Specifications of Clock Generation Circuit revised
		71	Figure 10.1 Clock Generation Circuit revised
		72	Figure 10.2 CM0 Register; NOTE6 deleted and NOTE9 revised
		74	Figure 10.4 OCD Register revised
		75	Figure 10.5 Registers FRA0 and FRA1; FRA0 register NOTE2 revised
		76	Figure 10.6 Registers FRA2, FRA4, and FRA6; FRA2 register NOTE2 deleted, registers FRA4 and FRA6 added
		77	Figure 10.8 VCA2 Register NOTE6 revised
		78	Figure 10.9 Examples of XIN Clock Connection Circuit NOTE1 revised
		79	10.2.2 High-Speed On-Chip Oscillator Clock revised
		81	10.4.3 Peripheral Function Clock (f1, f2, f4, f8, and f32) revised
		82	10.4.9 fC4 and fC32 added
		83	Table 10.2 Settings and Modes of Clock Associated Bits revised
		84	10.5.1.2 Low-Speed Clock Mode revised
		85	10.5.2.2 Entering Wait Mode and 10.5.2.3 Pin Status in Wait Mode revised
		86	10.5.2.4 Exiting Wait Mode; "When using a peripheral ...instruction is executed." page changed Table 10.3 Interrupts to Exit Wait Mode and Usage Conditions revised
		87	10.5.2.4 Exiting Wait Mode; "When exiting by a peripheral ... CPU clock supply is started." → "When exiting by a peripheral ... CM07 bit in the CM0 register." revised
		88	Figure 10.11 Time between Wait Mode and Interrupt Routine Execution added 10.5.2.5 Reducing the Internal Power Consumption added Figure 10.12 Handling Procedure of Internal Power Low Consumption Enabled by VCA20 bit revised

REVISION HISTORY

R8C/24 Group, R8C/25 Group Hardware Manual

Rev.	Date	Description	
		Page	Summary
1.00	May 31, 2006	89	Table 10.4 Interrupts to Exit Stop Mode and Usage Conditions revised
		90	Figure 10.13 Time between Stop Mode and Interrupt Routine Execution added
		92	10.6.1 How to Use Oscillation Stop Detection Function revised
		93	Figure 10.15 Procedure for Switching Clock Source from Low-Speed On-Chip Oscillator to XIN Clock revised
		94	Figure 10.16 Example of Determining Interrupt Source for Oscillation Stop Detection, Watchdog Timer, Voltage Monitor 1, or Voltage Monitor 2 Interrupt revised
		95	10.7.1 Stop Mode and Wait Mode revised and 10.7.4 fOCO40M deleted
		97	Figure 12.1 Interrupts revised
		107	Table 12.5 IPL Value When Software or Special Interrupt Is Acknowledged revised
		109	Figure 12.10 Priority Levels of Hardware Interrupts revised
		122	12.6.7 Entering Wait Mode after Oscillation Stop Detection Interrupt is Detected deleted
		123	Figure 13.1 Block Diagram of Watchdog Timer revised
		124	Figure 13.2 Registers OFS and WDC; OFS Register NOTE2 revised
		128	14. Timers; "The count source for each timer ... and reloading." deleted
		130	14.1 Timer RA; "The count source for timer RA ... and reloading." added Figure 14.1 Block Diagram of Timer RA revised
		131	Figure 14.2 Registers TRACR and TRAI0C revised
		132	Figure 14.3 Registers TRAMR, TRAPRE, and TRA revised
		133	Table 14.2 Timer Mode Specifications revised Figure 14.4 TRAI0C Register in Timer Mode revised (Figure 14.4 TRACR Register in Timer Mode deleted, Figure 14.5 Registers TRAI0C and TRAMR in Timer Mode TRAMR register deleted)
		134	14.1.1.1 Timer Write Control during Count added Figure 14.5 Operating Example of Timer RA when Count Value is Rewritten during Count added
		135	Table 14.3 Pulse Output Mode Specifications revised
		136	Figure 14.6 TRAI0C Register in Pulse Output Mode revised (Figure 14.6 Registers TRACR and TRAI0C in Pulse Output Mode TRACR register deleted, Figure 14.7 TRAMR Register in Pulse Output Mode deleted)
137	Table 14.4 Event Counter Mode Specifications revised		
138	Figure 14.7 TRAI0C Register in Event Counter Mode revised (Figure 14.8 Registers TRACR and TRAI0C in Event Counter Mode TRACR register deleted, Figure 14.9 TRAMR Register in Event Counter Mode deleted)		
139	Table 14.5 Pulse Width Measurement Mode Specifications revised		

REVISION HISTORY

R8C/24 Group, R8C/25 Group Hardware Manual

Rev.	Date	Description	
		Page	Summary
1.00	May 31, 2006	140	Figure 14.8 TRAIOC Register in Pulse Width Measurement Mode revised (Figure 14.10 Registers TRACR and TRAIOC in Pulse Width Measurement Mode TRACR register deleted, Figure 14.11 TRAMR Register in Pulse Width Measurement Mode deleted)
		141	Figure 14.9 Operating Example of Pulse Width Measurement Mode revised
		142	Table 14.6 Pulse Period Measurement Mode Specifications revised
		143	Figure 14.10 TRAIOC Register in Pulse Period Measurement Mode revised (Figure 14.13 Registers TRACR and TRAIOC in Pulse Period Measurement Mode TRACR register deleted, Figure 14.14 TRAMR Register in Pulse Period Measurement Mode deleted)
		144	Figure 14.11 Operating Example of Pulse Period Measurement Mode revised
		146	14.2 Timer RB; "The count source for timer RB ... and reloading." added <ul style="list-style-type: none"> • Timer mode: ... (peripheral function clock ... added Figure 14.12 Block Diagram of Timer RB revised
		147	Figure 14.13 Registers TRBCR and TRBOCR revised
		148	Figure 14.14 Registers TRBIOC and TRBMR revised
		149	Figure 14.15 Registers TRBPRES, TRBSC, and TRBPR revised
		150	Table 14.7 Timer Mode Specifications revised Figure 14.16 TRBIOC Register in Timer Mode revised (Figure 14.20 Registers TRBIOC and TRBMR in Timer Mode TRBMR register deleted)
		151	14.2.1.1 Timer Write Control during Count added
		152	Figure 14.17 Operating Example of Timer RB when Count Value is Rewritten during Count added
		153	Table 14.8 Programmable Waveform Generation Mode Specifications revised
		154	Figure 14.18 TRBIOC Register in Programmable Waveform Generation Mode revised (Figure 14.20 Registers TRBIOC and TRBMR in Timer Mode TRBMR register deleted) Figure 14.19 Operating Example of Timer RB in Programmable Waveform Generation Mode revised
		155	Table 14.9 Programmable One-Shot Generation Mode Specifications revised
		156	Figure 14.20 TRBIOC Register in Programmable One-Shot Generation Mode revised (Figure 14.23 Registers TRBIOC and TRBMR in Programmable One-Shot Generation Mode TRBMR register deleted)
		157	Figure 14.21 Operating Example of Programmable One-Shot Generation Mode revised
		158	14.2.3.1 Selecting One-shot Trigger added
		159	Table 14.10 Programmable Wait One-Shot Generation Mode Specifications revised

REVISION HISTORY

R8C/24 Group, R8C/25 Group Hardware Manual

Rev.	Date	Description	
		Page	Summary
1.00	May 31, 2006	161	Figure 14.22 TRBIOC Register in Programmable Wait One-Shot Generation Mode (Figure 14.25 Registers TRBIOC and TRBMR in Programmable Wait One-Shot Generation Mode TRBMR register deleted)
		162	Figure 14.23 Operating Example of Programmable Wait One-Shot Generation Mode revised
		163	14.2.5 Notes on Timer RB; “... Timer RB starts counting at the first ... 1 (during count).” deleted “When the TSTOP bit in the TRBCR register ... immediately stops. • If the TOSST bit or the TOSSP bit ... also be set to 0 or 1.” added
		165	Table 14.12 Pin Functions TRDIOA0/TRDCLK(P2_0) revised
		167	Table 14.20 Pin Functions INT0(P4_5) revised
		179	Figure 14.33 TRDFCR Register in Input Capture Function NOTE2 revised
		193	Figure 14.47 TRDFCR Register in Output Compare Function NOTE2 revised
		210	Figure 14.63 TRDFCR Register in PWM Mode NOTE2 revised
		220	Table 14.29 Reset Synchronous PWM Mode Specifications revised
		222	Figure 14.75 TRDFCR Register in Reset Synchronous PWM Mode NOTES 1 and 3 revised
		225	Figure 14.78 Registers TRDSR0 to TRDSR1 in Reset Synchronous PWM Mode revised
		227	Table 14.30 TRDGRji Register Functions in Reset Synchronous PWM Mode revised
		233	Figure 14.86 TRDFCR Register in Complementary PWM Mode NOTES 1 and 4 revised
		239	14.3.9 Complementary PWM Mode; “Since a value cannot be written to ... BFC1, and BFD1.” added
		244	Table 14.33 Specifications of PWM3 Mode revised
		247	Figure 14.98 TRDFCR Register in PWM3 Mode NOTE2 revised
		254	Table 14.34 TRDGRji Register Functions in PWM3 Mode revised, 14.3.10 PWM3 Mode; “Registers TRDGRC0, ... and BFD1.” added
		258	14.3.12.1 TRDSTR Register (i = 0 or 1); “Table 14.36 lists the TRDIOji (j = A, B, C, ... timer RD output.” added
		259	14.3.12.6 Reset Synchronous PWM Mode; Change procedure (2) revised 14.3.12.7 Complementary PWM Mode; •Change bits CMD1 to CMD0 in the TRDFCR register in the ... ; Change procedure: When setting to complementary ... (2) , Change procedure: When stopping complementary ... (1) and (2) revised •Do not write to ... ; “However, set to the TRDGRD0, ... BFD1.” added
		263	14.3.12.8 PWM3 Mode deleted
264	14.4 Timer RE; “The count source for timer RE ... operations.” added		
265	Figure 14.112 Block Diagram of Real-Time Clock Mode revised		

REVISION HISTORY

R8C/24 Group, R8C/25 Group Hardware Manual

Rev.	Date	Description	
		Page	Summary
1.00	May 31, 2006	287	Figure 15.6 Registers U0C1 to U1C1, U1SR, and PMR; U0C1 to U1C1 register NOTE2 added
		288	Table 15.1 Clock Synchronous Serial I/O Mode Specifications revised
		289	15.1 Clock Synchronous Serial I/O Mode; “Table 15.3 ... The TXD0 pin ...” → “Table 15.3 ... The TXDi pin ...” revised
		294	15.2 Clock Asynchronous Serial I/O (UART) Mode; “Table 15.6 ... The TXD0 pin ...” → “Table 15.6 ... The TXDi pin ...” revised
		296	Figure 15.11 Receive Timing Example in UART Mode; “RI bit” → “IR bit” revised
		300	Table 16.2 Clock Synchronous Serial I/O with Chip Select Specifications; “φ” → “f1” revised and NOTE2 deleted
		304	Figure 16.4 SSMR Register
		307	Figure 16.7 SSMR2 Register revised
		308	Figure 16.8 Registers SSTDR and SSRDR; SSTDR registers NOTE1 deleted
		309	16.2.1 Transfer Clock; “φ” → “f1” revised
		314	16.2.5.2 Data Transmission; “When setting the MCU is set as a slave device, ... enabled.” deleted
		316	Figure 16.14 Sample Flowchart of Data Transmission (Clock Synchronous Communication Mode) NOTE2 deleted
		319	16.2.5.4 Data Transmission/Reception; “When the MCU is set as the slave device, ... enabled.” deleted
		320	Figure 16.17 Sample Flowchart of Data Transmission/Reception (Clock Synchronous Communication Mode) NOTE2 deleted
		322	Figure 16.18 Initialization in 4-Wire Bus Communication Mode revised
		323	16.2.6.2 Data Transmission; “When the MCU is set as a slave device, ... enabled.” deleted
		358	Figure 16.47 Example of Register Setting in Master Receive Mode (I ² C bus Interface Mode) revised
		362 to 375	17. Hardware LIN; “Sync Break” → “Synch Break” and “Sync Field” → “Synch Field” revised
		362	Figure 17.1 Block Diagram of Hardware LIN revised
		364	Figure 17.2 LINCR Register revised
		365	Figure 17.3 LINST Register revised
		366	Figure 17.4 Typical Operation when Sending a Header Field “RAIC” → “TRAIC” revised
		367	Figure 17.5 Example of Header Field Transmission Flowchart (1) revised
		368	Figure 17.6 Example of Header Field Transmission Flowchart (2) revised
		369	17.4.2 Slave Mode (5) revised Figure 17.7 Typical Operation when Receiving a Header Field revised
		370	Figure 17.8 Example of Header Field Reception Flowchart (1) revised
		371	Figure 17.9 Example of Header Field Reception Flowchart (2) revised

REVISION HISTORY

R8C/24 Group, R8C/25 Group Hardware Manual

Rev.	Date	Description	
		Page	Summary
1.00	May 31, 2006	372	Figure 17.10 Example of Header Field Reception Flowchart (3) revised
		373	Figure 17.11 Typical Operation when a Bus Collision is Detected; "RAIC" → "TRAIC" revised
		374	17.5 Interrupt Requests; "There are four ... Sync Break generation completed, ... , and bus collision detection." → "There are three ... , and bus collision detection." revised
			Table 17.2 Interrupt Requests of Hardware LIN revised
		376	Table 18.1 Performance of A/D converter revised
		380	Table 18.2 One-Shot Mode Specifications revised
		384	Figure 18.6 ADCON0 Register in Repeat Mode revised
		386	18.3 Sample and Hold; "... to 28 φAD cycles for 8-bit resolution or 33 φAD resolution" and "When performing A/D conversion, charge the sampling time." deleted
		387	Figure 18.10 Internal Equivalent Circuit of Analog Input revised
		388	18.6 Inflow Current Bypass Circuit deleted 18.6 Output Impedance of Sensor under A/D Conversion added
		389	18.7 Notes on A/D Converter revised
		394	Figure 19.4 OFS Register NOTE2 revised
		395	Table 19.3 Differences between EW0 Mode and EW1 Mode revised
		397	19.4.2.1 FMR00 Bit "... (including suspend periods) ..." added
		399	Figure 19.5 FMR0 Register NOTE6 added
		401	Figure 19.7 FMR4 Register; NOTES 2, 3 and 4 revised and NOTE5 added
		402	Figure 19.8 Timing of Suspend Operation revised
		405	19.4.3.1 Read Array Command "The MCU also enters read array mode after a reset." added
			19.4.3.2 Read Status Register Command "The MCU remains in read status mode ... command is written." added
		406	19.4.3.4 Program Command; "When suspend function disabled, ...", "When suspend function enabled, the FMR44 bit ... when auto-programming completes." added
	Figure 19.12 Program Command (When Suspend Function Disabled) title revised		
407	Figure 19.13 Program Command (When Suspend Function Enabled) added		
408	19.4.3.5 Block Erase revised Figure 19.14 Block Erase Command (When Erase-Suspend Function Disabled) title revised		
409	Figure 19.15 Block Erase Command (When Erase-Suspend Function Enabled) revised		
410	Table 19.5 Status Register Bits revised		
413	19.5 Standard Serial I/O Mode revised Table 19.7 Pin Functions (Flash Memory Standard Serial I/O Mode 2) added		
414	Table 19.8 Pin Functions (Flash Memory Standard Serial I/O Mode 3) revised		

REVISION HISTORY

R8C/24 Group, R8C/25 Group Hardware Manual

Rev.	Date	Description	
		Page	Summary
1.00	May 31, 2006	415	Figure 19.17 Pin Connections for Standard Serial I/O Mode 3 title revised
		416	Figure 19.18 Pin Processing in Standard Serial I/O Mode 2 added, Figure 19.19 Pin Processing in Standard Serial I/O Mode 3 title revised
		420	19.7.1.7 Reset Flash Memory deleted
		421	Table 20.2 Recommended Operating Conditions revised
		422	Figure 20.1 Ports P0 to P4, P6 Timing Measurement Circuit; title revised
		423	Table 20.4 Flash Memory (Program ROM) Electrical Characteristics revised
		424	Table 20.5 Flash Memory (Data flash Block A, Block B) Electrical Characteristics revised
		425	Figure 20.2 Time delay until Suspend title revised
		426	Table 20.9 Voltage Monitor 0 Reset Electrical Characteristics → Table 20.9 Power-on Reset Circuit, Voltage Monitor 0 Reset Electrical Characteristics revised
			Table 20.10 Power-on Reset Circuit Electrical Characteristics (When Not Using Voltage Monitor 0 Reset) deleted
			Figure 20.3 Power-on Reset Circuit Electrical Characteristics revised
		427	Table 20.10 High-speed On-Chip Oscillator Circuit Electrical Characteristics revised
			Table 20.11 Low-speed On-Chip Oscillator Circuit Electrical Characteristics revised
		434	Table 20.16 Electrical Characteristics (2) [Vcc = 5 V] revised
		438	Table 20.22 Electrical Characteristics (4) [Vcc = 3 V] revised
		442	Table 20.28 Electrical Characteristics (6) [Vcc = 2.2 V] revised
		445	21.1.1 Stop Mode and Wait Mode revised and 21.1.4 fOCO40M deleted
		448	21.2.7 Entering Wait Mode after Oscillation Stop Detection Interrupt is Detected deleted
		450	21.3.2 Notes on Timer RB; <ul style="list-style-type: none"> “• ... Timer RB starts counting at the first ... 1 (during count).” deleted “• When the TSTOP bit in the TRBCR register ... immediately stops. • If the TOSST bit or the TOSSP bit ... also be set to 0 or 1.” added
		451	21.3.3.1 TRDSTR Register (i = 0 or 1) revised
452	21.3.3.6 Reset Synchronous PWM Mode; Change procedure (2) revised 21.3.3.7 Complementary PWM Mode; <ul style="list-style-type: none"> •Change bits CMD1 to CMD0 in the TRDFCR register in the ...; Change procedure: When setting to complementary ... (2) , Change procedure: When stopping complementary ... (1) and (2) revised •Do not write to ...; “However, set to the TRDGRD0, ... BFD1.” added 		
456	21.3.3.8 PWM3 Mode deleted		
462	21.6 Notes on Hardware LIN; “Sync Break” → “Synch Break” revised		
463	21.7 Notes on A/D Converter revised		
466	21.8.1.7 Reset Flash Memory deleted		

REVISION HISTORY

R8C/24 Group, R8C/25 Group Hardware Manual

Rev.	Date	Description	
		Page	Summary
1.00	May 31, 2006	468	22. Notes on On-Chip Debugger; (2) revised
		469	Appendix 1. Package Dimensions "The latest package ... Renesas Technology website." added
2.00	Nov 01, 2006	all pages	"PTLG0064JA-A (64F0G)" package added Y version added Factory programming product added
		1	1. Overview; "... or a 64-pin molded-plastic FLGA." added
		2, 3	Table 1.1 Functions and Specifications for R8C/24 Group, Table 1.2 Functions and Specifications for R8C/25 Group; Package: "64-pin molded-plastic FLGA" added
		9	Figure 1.4 PLQP0052JA-A Package Pin Assignments (Top View); NOTE3 revised
		10	Figure 1.5 PTLG0064JA-A Package Pin Assignments added
		18	Table 4.1 revised
		36	Figure 6.5 NOTE6 revised
		61	Table 7.17 revised
		62	Table 7.19 revised
		66	Table 7.33, Table 7.35 revised
		67	Table 7.36 revised
		78	Figure 10.5 NOTE2 added
		80	Figure 10.8 NOTE6 revised
		81	Figure 10.9 revised
		82	10.2.2 "Adjust the FRA1 register so that 40 MHz or less." added
		90	Figure 10.11 revised
		91	Figure 10.12 revised
		93	Figure 10.13 revised
		98	10.7.1 revised, 10.7.2 added
		123	12.6.3 "and Table 20.18 (VCC = 5V), ... TRAI0 Input, INT1 Input." deleted
127	Figure 13.2; Watchdog Timer Control Register: After Reset "When read, the content is undefined." added		
140	Table 14.4; TRAO pin function: Specification "or pulse output" added		
198	Figure 14.49 NOTE2 added		
215	Figure 14.65 Timer RD Output Control Register NOTE2 added		
220	Figure 14.71 revised		
252	Figure 14.100 NOTE2 added		
262	14.3.12.7 "Do not use the TRDGRC0 register in complementary PWM mode." deleted		
291	Table 15.1 NOTE2 revised		
296	Table 15.4 NOTE1 revised		

REVISION HISTORY

R8C/24 Group, R8C/25 Group Hardware Manual

Rev.	Date	Description	
		Page	Summary
2.00	Nov 01, 2006	298	Figure 15.10 revised
		306	Figure 16.3 NOTE2 revised
		337	Figure 16.26 NOTE3 revised
		344 to 349	Figure 16.32, Figure 16.33, Figure 16.34, Figure 16.35, Figure 16.36 revised
		370	Figure 17.5 revised
		374	Figure 17.9 revised
		375	Figure 17.10 revised
		377	17.4.4 added
		378	Table 17.2 Cause of Interrupt "8" → "6"
		384	Table 18.2; Stop condition: Specification "when the ADCAP (software trigger)" added, Input pin: Specification "AN8" → "AN0"
		395	Figure 19.1 revised
		396	Figure 19.2 revised
		411	Figure 19.13 NOTE3 added
		413	Figure 19.15 NOTE3 added
		416	Figure 19.16 revised
		425	Table 20.1 Absolute Maximum Ratings; NOTE1 added
		432	Table 20.10; "Vcc = 4.5 V to 5.5 V -20°C ≤ Topr ≤ 85°C", "Vcc = 4.5 V to 5.5 V -40°C ≤ Topr ≤ 85°C" added Oscillation stability time: Condition "Vcc = 5.0 V, Topr = 25°C" deleted Table 5.11; Oscillation stability time: Condition "Vcc = 5.0 V, Topr = 25°C" deleted
		438	Table 20.15; I _{IH} , I _I L, R _{PULLUP} Condition: "Vcc = 5V" added
		439	Table 20.16; Condition: High-speed on-chip oscillator mode revised
		440	Table 20.17 added
		441	Figure 20.8 revised
		443	Table 20.22; I _{IH} , I _I L, R _{PULLUP} Condition: "Vcc = 3V" added
		444	Table 20.23; Condition "Increase during A/D converter operation" added
445	Figure 20.12 revised		
448	Table 20.29; Condition "Increase during A/D converter operation" added		
449	Figure 20.16 revised		
475	Package Dimensions; "PTLG0064JA-A (64F0G)" added		

R8C/24 Group, R8C/25 Group Hardware Manual

Publication Data: Rev.0.10 Jul 27, 2005
Rev.2.00 Nov 01, 2006

Published by: Sales Strategic Planning Div.
Renesas Technology Corp.

© 2006. Renesas Technology Corp., All rights reserved. Printed in Japan

R8C/24 Group, R8C/25 Group Hardware Manual



Renesas Technology Corp.
2-6-2, Ote-machi, Chiyoda-ku, Tokyo, 100-0004, Japan