

LCD Application Board V2

User's Manual

RENESAS STARTER KIT

All information contained in these materials, including products and product specifications, represents information on the product at the time of publication and is subject to change by Renesas Electronics Corporation without notice. Please review the latest information published by Renesas Electronics Corporation through various means, including the Renesas Electronics Corporation website (<http://www.renesas.com>).

Notice

1. Descriptions of circuits, software and other related information in this document are provided only to illustrate the operation of semiconductor products and application examples. You are fully responsible for the incorporation of these circuits, software, and information in the design of your equipment. Renesas Electronics assumes no responsibility for any losses incurred by you or third parties arising from the use of these circuits, software, or information.
2. Renesas Electronics has used reasonable care in preparing the information included in this document, but Renesas Electronics does not warrant that such information is error free. Renesas Electronics assumes no liability whatsoever for any damages incurred by you resulting from errors in or omissions from the information included herein.
3. Renesas Electronics does not assume any liability for infringement of patents, copyrights, or other intellectual property rights of third parties by or arising from the use of Renesas Electronics products or technical information described in this document. No license, express, implied or otherwise, is granted hereby under any patents, copyrights or other intellectual property rights of Renesas Electronics or others.
4. You should not alter, modify, copy, or otherwise misappropriate any Renesas Electronics product, whether in whole or in part. Renesas Electronics assumes no responsibility for any losses incurred by you or third parties arising from such alteration, modification, copy or otherwise misappropriation of Renesas Electronics product.
5. Renesas Electronics products are classified according to the following two quality grades: "Standard" and "High Quality". The recommended applications for each Renesas Electronics product depends on the product's quality grade, as indicated below.

"Standard": Computers; office equipment; communications equipment; test and measurement equipment; audio and visual equipment; home electronic appliances; machine tools; personal electronic equipment; and industrial robots etc.

"High Quality": Transportation equipment (automobiles, trains, ships, etc.); traffic control systems; anti-disaster systems; anticrime systems; and safety equipment etc.

Renesas Electronics products are neither intended nor authorized for use in products or systems that may pose a direct threat to human life or bodily injury (artificial life support devices or systems, surgical implantations etc.), or may cause serious property damages (nuclear reactor control systems, military equipment etc.). You must check the quality grade of each Renesas Electronics product before using it in a particular application. You may not use any Renesas Electronics product for any application for which it is not intended. Renesas Electronics shall not be in any way liable for any damages or losses incurred by you or third parties arising from the use of any Renesas Electronics product for which the product is not intended by Renesas Electronics.

6. You should use the Renesas Electronics products described in this document within the range specified by Renesas Electronics, especially with respect to the maximum rating, operating supply voltage range, movement power voltage range, heat radiation characteristics, installation and other product characteristics. Renesas Electronics shall have no liability for malfunctions or damages arising out of the use of Renesas Electronics products beyond such specified ranges.
7. Although Renesas Electronics endeavors to improve the quality and reliability of its products, semiconductor products have specific characteristics such as the occurrence of failure at a certain rate and malfunctions under certain use conditions. Further, Renesas Electronics products are not subject to radiation resistance design. Please be sure to implement safety measures to guard them against the possibility of physical injury, and injury or damage caused by fire in the event of the failure of a Renesas Electronics product, such as safety design for hardware and software including but not limited to redundancy, fire control and malfunction prevention, appropriate treatment for aging degradation or any other appropriate measures. Because the evaluation of microcomputer software alone is very difficult, please evaluate the safety of the final products or systems manufactured by you.
8. Please contact a Renesas Electronics sales office for details as to environmental matters such as the environmental compatibility of each Renesas Electronics product. Please use Renesas Electronics products in compliance with all applicable laws and regulations that regulate the inclusion or use of controlled substances, including without limitation, the EU RoHS Directive. Renesas Electronics assumes no liability for damages or losses occurring as a result of your noncompliance with applicable laws and regulations.
9. Renesas Electronics products and technology may not be used for or incorporated into any products or systems whose manufacture, use, or sale is prohibited under any applicable domestic or foreign laws or regulations. You should not use Renesas Electronics products or technology described in this document for any purpose relating to military applications or use by the military, including but not limited to the development of weapons of mass destruction. When exporting the Renesas Electronics products or technology described in this document, you should comply with the applicable export control laws and regulations and follow the procedures required by such laws and regulations.
10. It is the responsibility of the buyer or distributor of Renesas Electronics products, who distributes, disposes of, or otherwise places the product with a third party, to notify such third party in advance of the contents and conditions set forth in this document, Renesas Electronics assumes no responsibility for any losses incurred by you or third parties as a result of unauthorized use of Renesas Electronics products.
11. This document may not be reproduced or duplicated in any form, in whole or in part, without prior written consent of Renesas Electronics.
12. Please contact a Renesas Electronics sales office if you have any questions regarding the information contained in this document or Renesas Electronics products, or if you have any other inquiries.

(Note 1) "Renesas Electronics" as used in this document means Renesas Electronics Corporation and also includes its majority owned subsidiaries.

(Note 2) "Renesas Electronics product(s)" means any product developed or manufactured by or for Renesas Electronics.

Disclaimer

By using this RSK Application Board, the user accepts the following terms:

The board is not guaranteed to be error free, and the entire risk as to the results and performance of the board is assumed by the User. The board is provided by Renesas on an "as is" basis without warranty of any kind whether express or implied, including but not limited to the implied warranties of satisfactory quality, fitness for a particular purpose, title and non-infringement of intellectual property rights with regard to the board. Renesas expressly disclaims all such warranties. Renesas or its affiliates shall in no event be liable for any loss of profit, loss of data, loss of contract, loss of business, damage to reputation or goodwill, any economic loss, any reprogramming or recall costs (whether the foregoing losses are direct or indirect) nor shall Renesas or its affiliates be liable for any other direct or indirect special, incidental or consequential damages arising out of or in relation to the use of this board, even if Renesas or its affiliates have been advised of the possibility of such damages.

Precautions

The following precautions should be observed when operating any RSK Application Board:

This RSK Application Board is only intended for use in a laboratory environment under ambient temperature and humidity conditions. A safe separation distance should be used between this and any sensitive equipment. Its use outside the laboratory, classroom, study area or similar such area invalidates conformity with the protection requirements of the Electromagnetic Compatibility Directive and could lead to prosecution.

The product generates, uses, and can radiate radio frequency energy and may cause harmful interference to radio communications. However, there is no guarantee that interference will not occur in a particular installation. If this equipment causes harmful interference to radio or television reception, which can be determined by turning the equipment off or on, you are encouraged to try to correct the interference by one or more of the following measures;

- ensure attached cables do not lie across the equipment
- reorient the receiving antenna
- increase the distance between the equipment and the receiver
- connect the equipment into an outlet on a circuit different from that which the receiver is connected
- power down the equipment when not in use
- consult the dealer or an experienced radio/TV technician for help NOTE: It is recommended that wherever possible shielded interface cables are used.

The product is potentially susceptible to certain EMC phenomena. To mitigate against them it is recommended that the following measures be undertaken;

- The user is advised that mobile phones should not be used within 10m of the product when in use.
- The user is advised to take ESD precautions when handling the equipment.

The RSK Application Board does not represent an ideal reference design for an end product and does not fulfil the regulatory standards for an end product.

How to Use This Manual

1. Purpose and Target Readers

This manual is designed to provide the user with an understanding of the RSK Application Board hardware functionality, and electrical characteristics. It is intended for users designing sample code on the RSK platform, using the many different incorporated peripheral devices.

The manual comprises of an overview of the capabilities of the RSK Application Board product, but does not intend to be a guide to embedded programming or hardware design. Further details regarding setting up an RSK for use with this Application Board may be found in the RSK's Tutorial Manual.

Particular attention should be paid to the precautionary notes when using the manual. These notes occur within the body of the text, at the end of each section, and in the Usage Notes section.

The revision history summarizes the locations of revisions and additions. It does not list all revisions. Refer to the text of the manual for details.

The following documents apply to the LCD Application Board. Make sure to refer to the latest versions of these documents. The newest versions of the documents listed may be obtained from the Renesas Electronics Web site.

| Document Type | Description | Document Title | Document No. |
|-------------------|---|--|--------------|
| User's Manual | Describes the technical details of the RSK Application Board hardware. | LCD Application Board V2 User's Manual | R20UT2518EG |
| Quick Start Guide | Provides simple instructions to setup the RSK and run the first sample, on a single A4 sheet. | LCD Application Board V2 Quick Start Guide | R20UT2519EG |
| Schematics | Full detail circuit schematics of the Application Board | LCD Application Board V2 Schematics | REG99J0041 |

2. List of Abbreviations and Acronyms

| Abbreviation | Full Form |
|--------------|-------------------------|
| CPU | Central Processing Unit |
| E1 | On-chip Debugger |
| LCD | Liquid Crystal Display |
| LED | Light Emitting Diode |
| MCU | Micro-controller Unit |
| RSK | Renesas Starter Kit |

Table of Contents

| | |
|---|----|
| 1. Overview..... | 7 |
| 1.1 Purpose..... | 7 |
| 1.2 Features..... | 7 |
| 2. Board Layout..... | 8 |
| 2.1 Component Layout..... | 8 |
| 2.2 Board Dimensions..... | 9 |
| 2.1 Component Reference..... | 10 |
| 3. Installation & Specifications..... | 11 |
| 3.1 Assembly and Interfacing..... | 11 |
| 3.2 LCD Module Specifications..... | 12 |
| 4. Headers..... | 13 |
| 4.1 LCD Application Header..... | 13 |
| 5. Modifications..... | 14 |
| 5.1 Using the Unconnected Segments..... | 14 |
| 5.2 Capacitors..... | 14 |
| 6. Additional Information..... | 15 |

1. Overview

1.1 Purpose

This RSK Application Board is an evaluation tool for Renesas microcontrollers with an LCD driver interface. It is used in conjunction with the RSK for the microcontroller to be evaluated.

1.2 Features

This RSK Application Board provides the following features:

- Simple mounting connections for LCD to fit on top of RSK.
- Interface to standard RSK LCD expansion connector and RSK expansion connections.
- LCD is powered straight from the MCU, requiring no extra connections
- 176 segment display, consisting of:
 - Large 3 digit numerical display, with decimal point
 - 5 digit numerical display, with decimal point & clock colon
 - 6 digit alphanumerical display
 - 4 bar battery gauge, and 6 bar graph
 - Day of the week indicators
 - 17 miscellaneous symbols

2. Board Layout

2.1 Component Layout

Figure 2-1 below shows the functions of the components on the board.

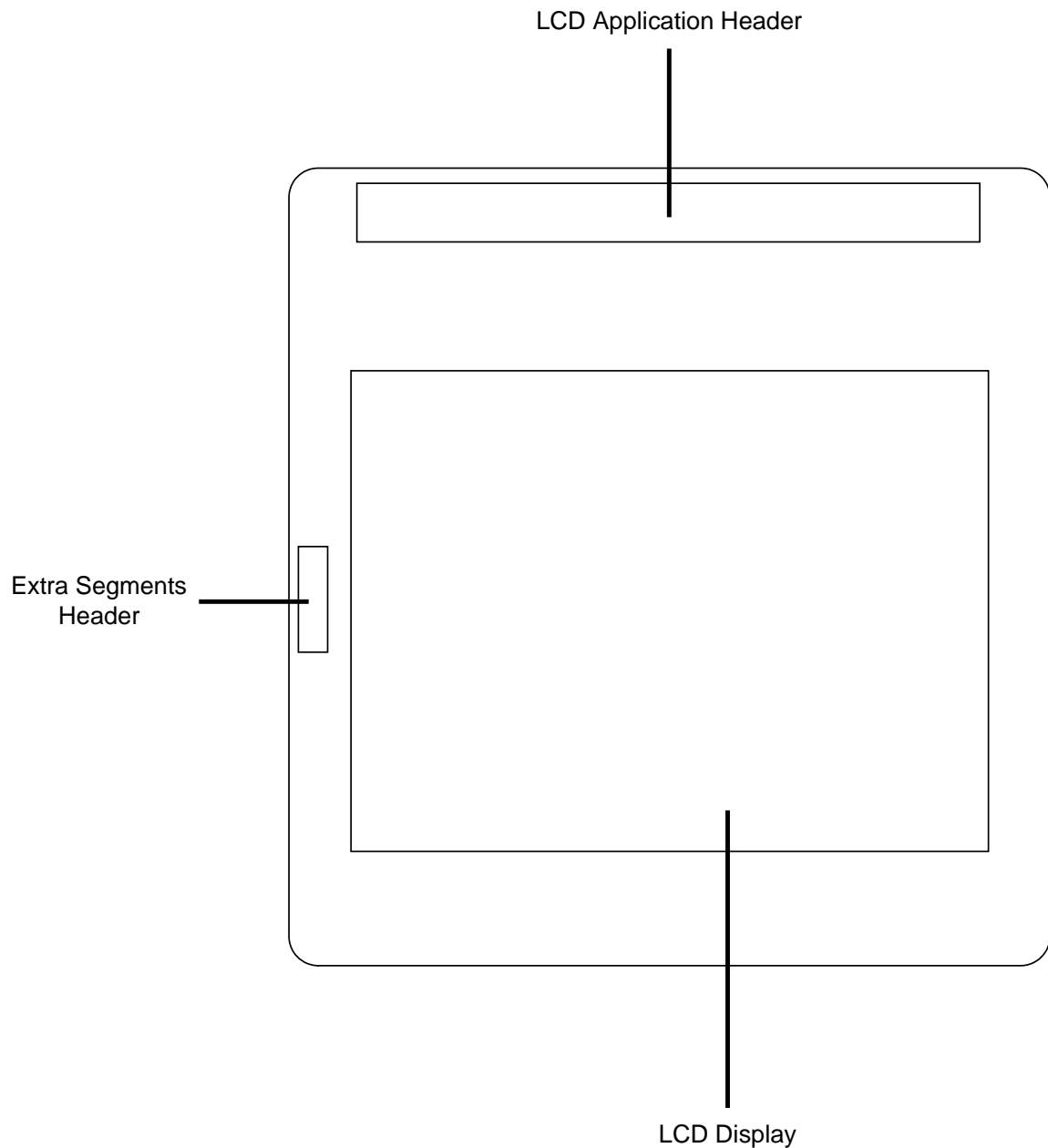

Figure 2-1: Board Dimensions

2.2 Board Dimensions

Figure 2-2 below gives the board dimensions and connector positions. All through hole connectors are on a common 0.1" grid for easy interfacing.

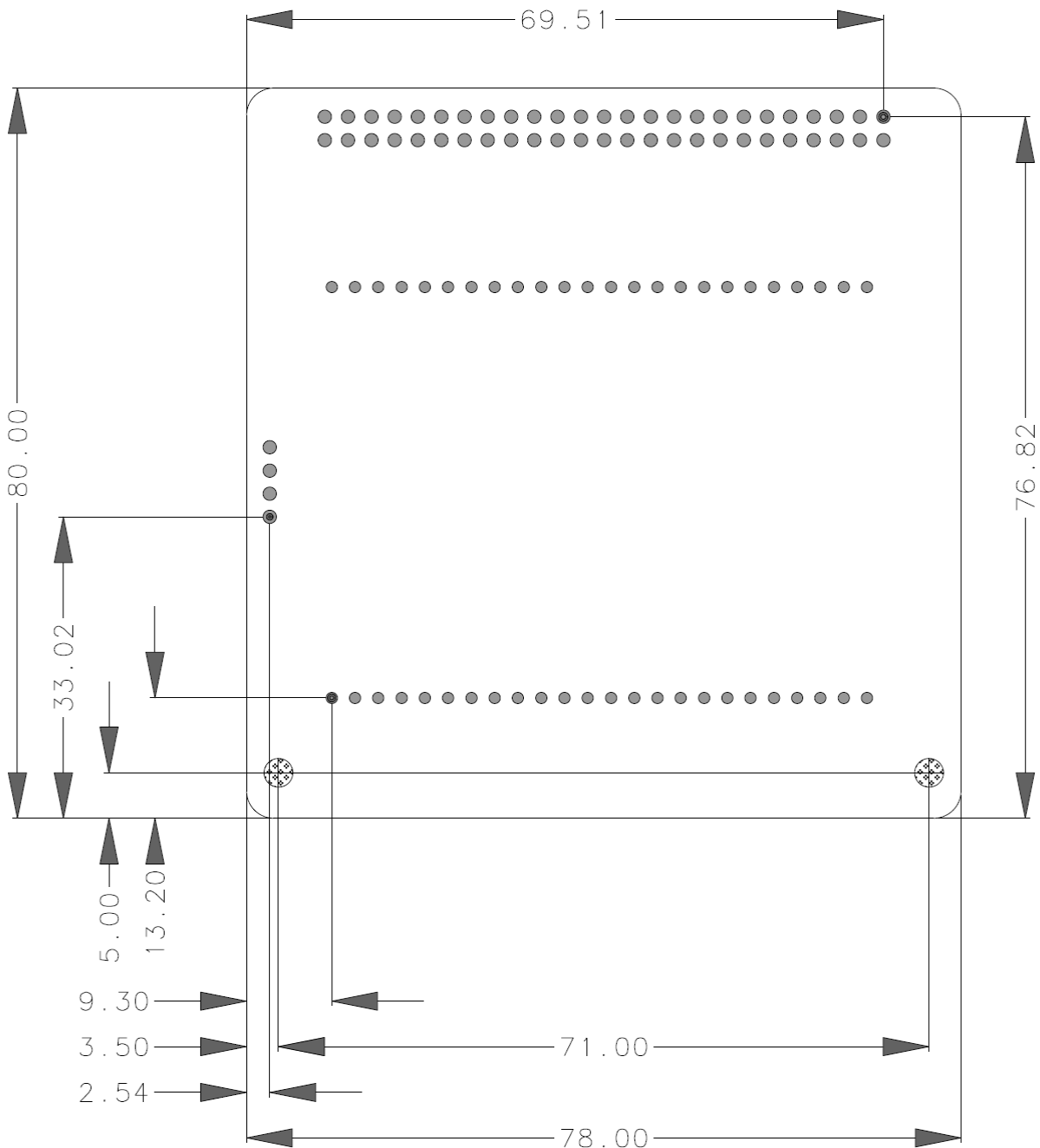

Figure 2-2: Board Dimensions

2.3 Component Reference

Figure 2-3 below shows the component references for the board.

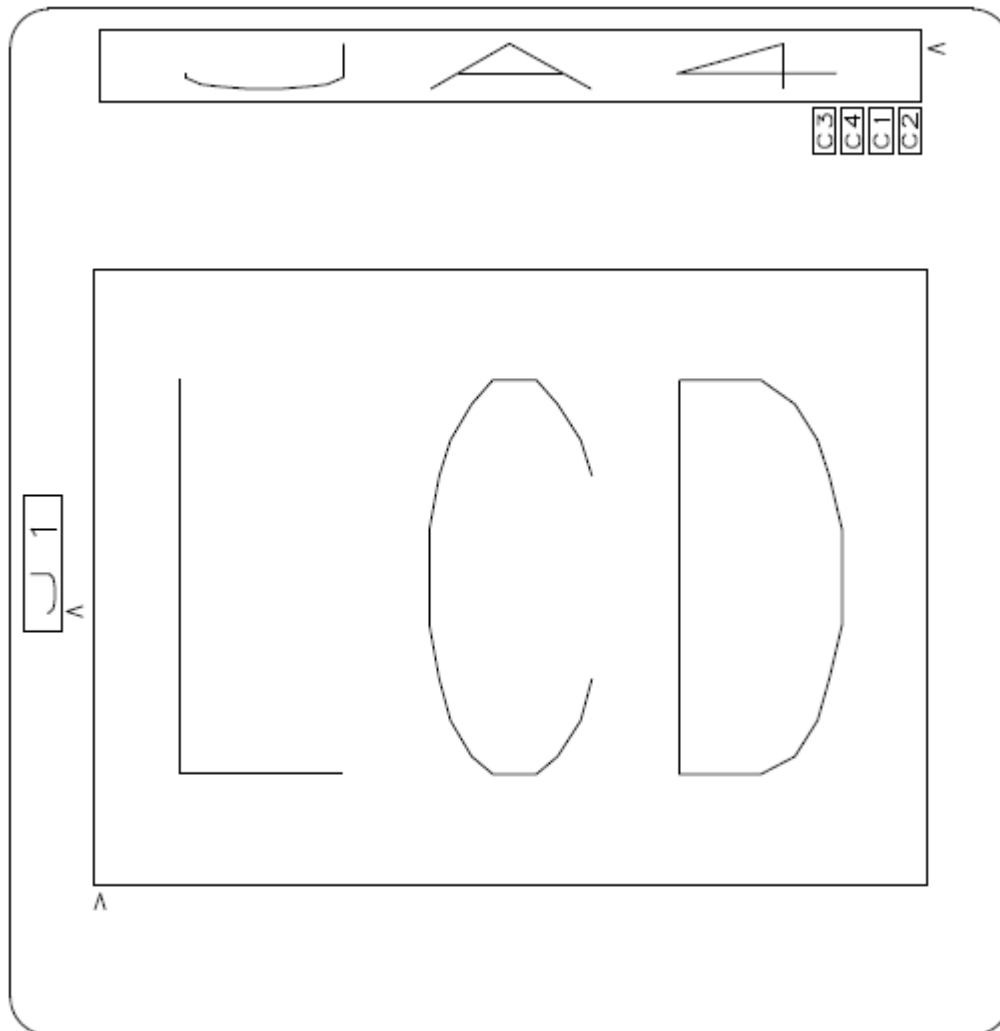

Figure 2-3: Component References

3. Installation & Specifications

3.1 Assembly and Interfacing

The LCD Application Board is fitted with a 50 way header marked as 'JA4' and RSK board is fitted with a 50 way socket marked as 'JA4'. The nylon pillars should be screwed onto the LCDAPPV2 board via the two holes located at the bottom of the PCB. The LCD Application Board should plug into the fitted socket on the top side of the RSK. Please refer to figure 3-1 for further details regarding assembly, and 3-2 for fitting details.

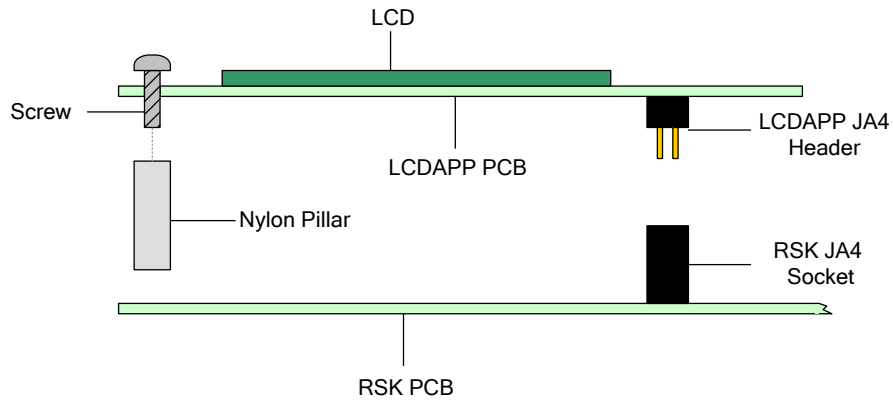

Figure 3-1: Assembly Diagram

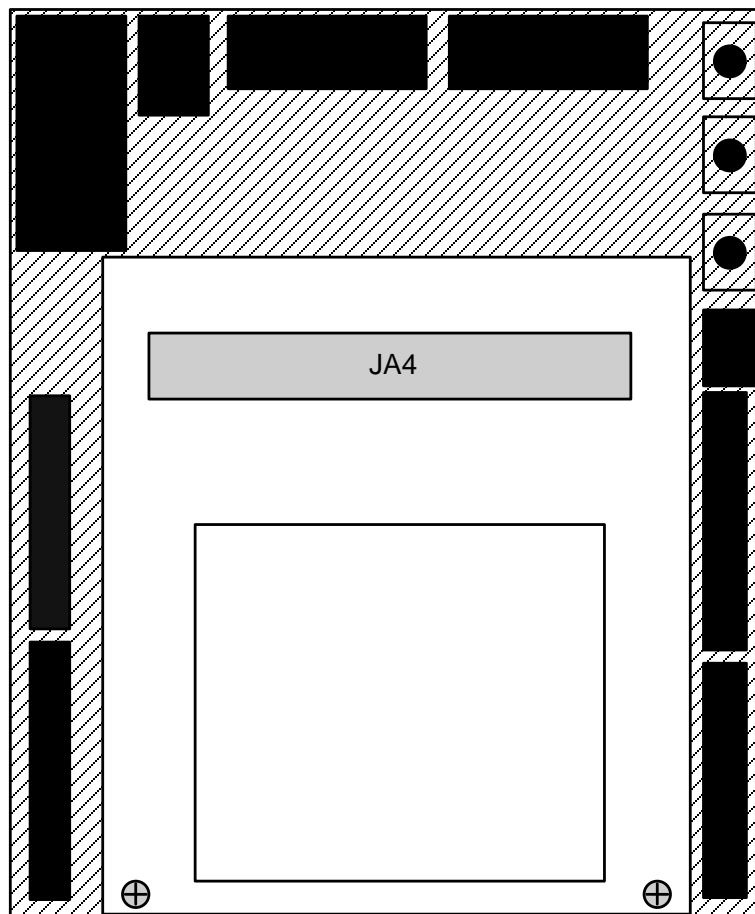

Figure 3-2: Board Fitting Diagram

3.2 LCD Module Specifications

The LCD module fitted to the LCDAPPV2 board is a custom glass, twisted nematic device.

Specifications:

- 176 Segments, 48 Pins
- 1/4 Duty Cycle, Using 4 Common Pins
- 4.2V Operating Voltage, 1/3 Voltage Bias
- 6 O'clock Viewing Direction, Reflective Positive

Please refer the LCD Glass datasheet for further details

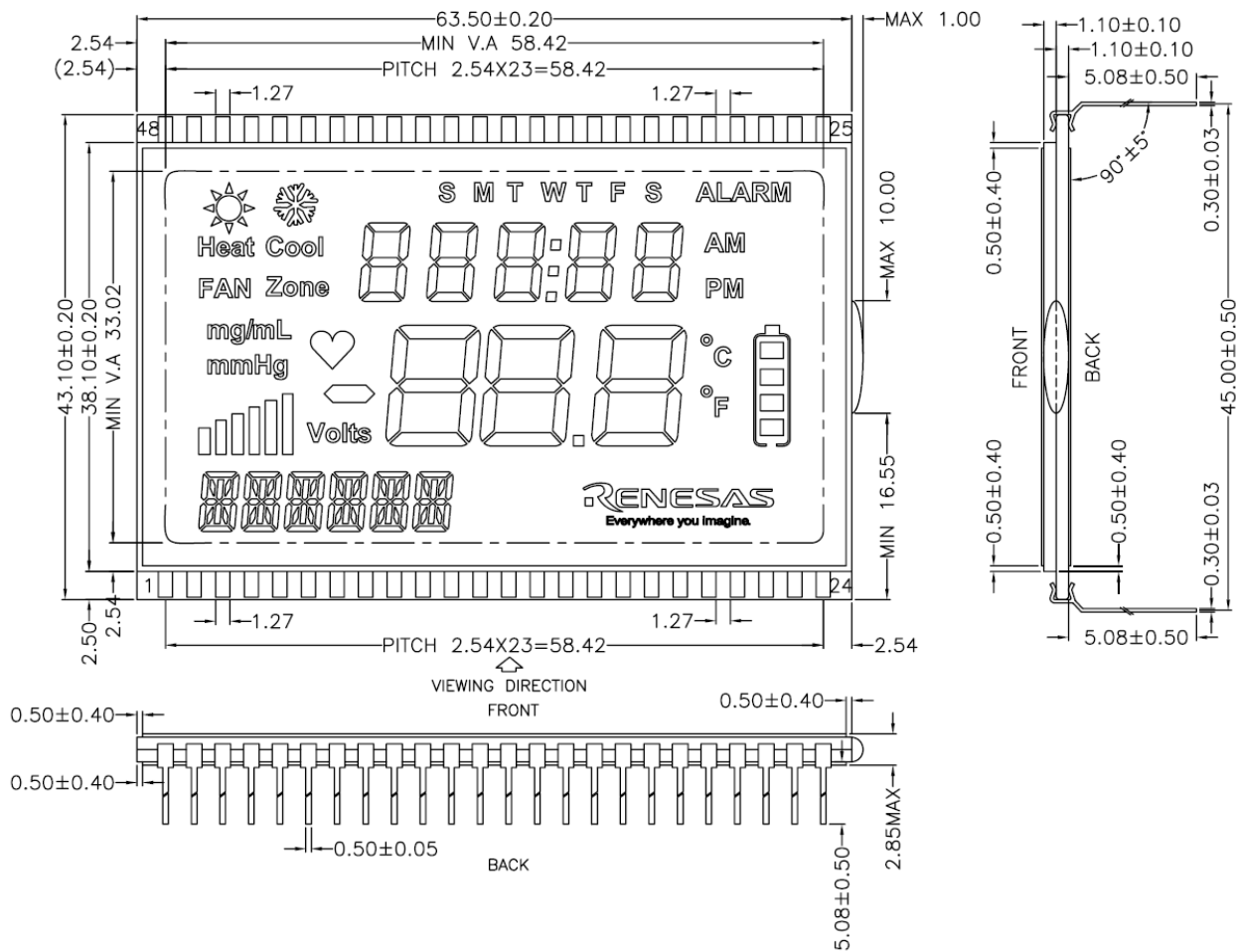

4. Headers

4.1 LCD Application Header

Due to technical limitations, the connection between the LCDAPPV2 and RSK devices does not preserve net names. The header details are listed here, and should be used as a lookup table when attempting to access specific segments on the LCDAPPV2 board manually.

| JA4 | | | | | |
|-----|---------------------|----------|-----|---------------------|----------|
| Pin | Generic Header Name | LCDAPPV2 | Pin | Generic Header Name | LCDAPPV2 |
| 1 | V1 | V1 | 2 | V2 | V2 |
| 3 | V3 | V3 | 4 | V4 | V4 |
| 5 | GROUND | GND | 6 | GROUND | GND |
| 7 | COM1 | COM1 | 8 | COM2 | COM2 |
| 9 | COM3 | COM3 | 10 | COM4 | COM4 |
| 11 | SEG1 | SEG3 | 12 | SEG2 | SEG4 |
| 13 | SEG3 | SEG5 | 14 | SEG4 | SEG6 |
| 15 | SEG5 | SEG7 | 16 | SEG6 | SEG8 |
| 17 | SEG7 | SEG9 | 18 | SEG8 | SEG10 |
| 19 | SEG9 | SEG11 | 20 | SEG10 | SEG12 |
| 21 | SEG11 | SEG13 | 22 | SEG12 | SEG14 |
| 23 | SEG13 | SEG15 | 24 | SEG14 | SEG16 |
| 25 | SEG15 | SEG17 | 26 | SEG16 | SEG18 |
| 27 | SEG17 | SEG19 | 28 | SEG18 | SEG20 |
| 29 | SEG19 | SEG21 | 30 | SEG20 | SEG22 |
| 31 | SEG21 | SEG23 | 32 | SEG22 | SEG24 |
| 33 | SEG23 | SEG25 | 34 | SEG24 | SEG26 |
| 35 | SEG25 | SEG27 | 36 | SEG26 | SEG28 |
| 37 | SEG27 | SEG29 | 38 | SEG28 | SEG30 |
| 39 | SEG29 | SEG31 | 40 | SEG30 | SEG32 |
| 41 | SEG31 | SEG33 | 42 | SEG32 | SEG34 |
| 43 | SEG33 | SEG35 | 44 | SEG34 | SEG36 |
| 45 | SEG35 | SEG37 | 46 | SEG36 | SEG38 |
| 47 | SEG37 | SEG39 | 48 | SEG38 | SEG40 |
| 49 | SEG39 | SEG41 | 50 | SEG40 | SEG42 |

Table 4-1 JA4 LCD Expansion Connector

5. Modifications

5.1 Using the Unconnected Segments

Due to limitations in the LCD Application Header (JA4), 4 of the LCD segment pins have been disconnected. The pins unconnected are 5, 6, 47 & 48. They can however be accessed via J1 on the LCDAPPV2 board. By connecting the pins to unused LCD segment pins on the RSK, unsupported segments can be used.

5.2 Capacitors

Pads are supplied to allow 0603 capacitors to be placed on the LCD drive voltages V1 – V4 (Components C1, C2, C3, C4 marked DNF).

6. Additional Information

Technical Support

For details on how to use the RSK or development tools, refer to the manuals available on the CD/DVD or from the web site.

Technical Contact Details

Please refer to the contact details listed in section 3 of the “Quick Start Guide”

General information on Renesas microcontrollers can be found on the Renesas website at:

<http://www.renesas.com/>

Trademarks

All brand or product names used in this manual are trademarks or registered trademarks of their respective companies or organisations.

Copyright

This document may be, wholly or partially, subject to change without notice. All rights reserved. Duplication of this document, either in whole or part is prohibited without the written permission of Renesas Electronics Europe Limited.

© 2013 Renesas Electronics Europe Limited. All rights reserved.

© 2013 Renesas Electronics Corporation. All rights reserved.

© 2013 Renesas Solutions Corp. All rights reserved.

| | |
|-------------------------|---|
| REVISION HISTORY | RSK LCD Application Board V2 User's Manual |
|-------------------------|---|

| Rev. | Date | Description | |
|-------------|--------------|--------------------|----------------------|
| | | Page | Summary |
| 1.00 | Feb 26, 2013 | — | First Edition issued |

RSK Application Board: User's Manual

Publication Date: Rev. 1.00 Feb 26, 2013

Published by: Renesas Electronics Corporation



Renesas Electronics Corporation

<http://www.renesas.com>

SALES OFFICES

Refer to "<http://www.renesas.com/>" for the latest and detailed information.

Renesas Electronics America Inc.

2880 Scott Boulevard Santa Clara, CA 95050-2554, U.S.A.
Tel: +1-408-588-6000, Fax: +1-408-588-6130

Renesas Electronics Canada Limited

1101 Nicholson Road, Newmarket, Ontario L3Y 9C3, Canada
Tel: +1-905-898-5441, Fax: +1-905-898-3220

Renesas Electronics Europe Limited

Dukes Meadow, Millboard Road, Bourne End, Buckinghamshire, SL8 5FH, U.K
Tel: +44-1628-651-700, Fax: +44-1628-651-804

Renesas Electronics Europe GmbH

Arcadiastrasse 10, 40472 Düsseldorf, Germany
Tel: +49-211-65030, Fax: +49-211-6503-1327

Renesas Electronics (China) Co., Ltd.

7th Floor, Quantum Plaza, No.27 ZhiChunLu Haidian District, Beijing 100083, P.R.China
Tel: +86-10-8235-1155, Fax: +86-10-8235-7679

Renesas Electronics (Shanghai) Co., Ltd.

Unit 204, 205, AZIA Center, No.1233 Lujiazui Ring Rd., Pudong District, Shanghai 200120, China
Tel: +86-21-5877-1818, Fax: +86-21-6887-7858 / -7898

Renesas Electronics Hong Kong Limited

Unit 1601-1613, 16/F., Tower 2, Grand Century Place, 193 Prince Edward Road West, Mongkok, Kowloon, Hong Kong
Tel: +852-2886-9318, Fax: +852 2886-9022/9044

Renesas Electronics Taiwan Co., Ltd.

13F, No. 363, Fu Shing North Road, Taipei, Taiwan
Tel: +886-2-8175-9600, Fax: +886 2-8175-9670

Renesas Electronics Singapore Pte. Ltd.

80 Bendemeer Road, Unit #06-02 Hyflux Innovation Centre Singapore 339949
Tel: +65-6213-0200, Fax: +65-6213-0300

Renesas Electronics Malaysia Sdn.Bhd.

Unit 906, Block B, Menara Amcorp, Amcorp Trade Centre, No. 18, Jln Persiaran Barat, 46050 Petaling Jaya, Selangor Darul Ehsan, Malaysia
Tel: +60-3-7955-9390, Fax: +60-3-7955-9510

Renesas Electronics Korea Co., Ltd.

11F., Samik Lavied' or Bldg., 720-2 Yeoksam-Dong, Kangnam-Ku, Seoul 135-080, Korea
Tel: +82-2-558-3737, Fax: +82-2-558-5141

LCD Application Board V2