

M62342P/FP, M62343P/FP

R03DS0040EJ0500

Rev.5.00

Jun 03, 2011

8-Bit D/A Converter (Buffered)

Description

The M62342 and M62343 are CMOS-structure semiconductor integrated circuits incorporating two or three 8-bit D/A converter channels with output buffer op-amps.

Serial data transfer type input can easily be used through a combination of three lines: DI, CLK, and LD.

Outputs incorporate buffer op-amps that have a drive capacity of 1 mA or above for both sink and source, and can operate over the entire voltage range from almost ground to V_{CC} (0 to 5 V), making peripheral elements unnecessary and enabling configuration of a system with few component parts.

Features

- Data transfer format
10-bit serial data input type
- Output buffer op-amps
Operable over entire voltage range from almost ground to V_{CC} (0 to 5 V)
- High output current capacity
 ± 1 mA or higher

Application

Signal gain setting and automatic adjustment in CTV, and display monitors, conversion from digital data to analog data in consumer and industrial products

Block Diagram

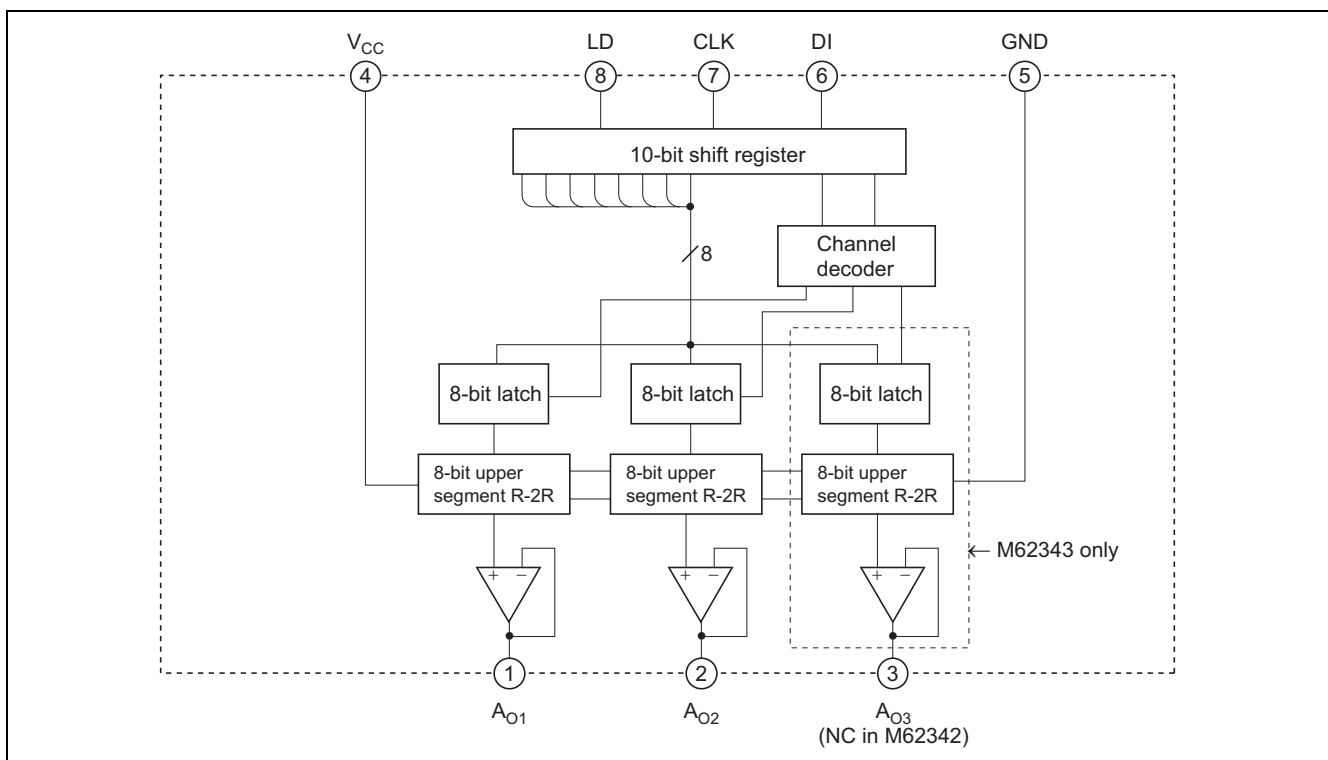

Pin Arrangement

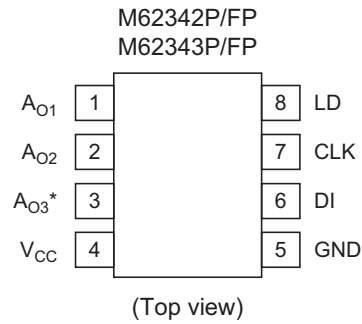

Outline: PRDP0008AA-A (8P4) [P] (not recommend for new design)
 PRSP0008DE-C [FP] (recommend)
 PRSP0008DA-A (8P2S-A) [FP] (not recommend for new design)

Note: Pin 3 of the M62342 is a NC pin.

Pin Description

Pin No.	Symbol	Function
6	DI	Serial data input pin. Inputs serial data with a 10-bit data length.
7	CLK	Serial clock input pin. Input signal from DI pin is input to 10-bit shift register at rise of shift clock.
8	LD	Load pin. When "H" level is input to LD pin, value in 10-bit shift register is loaded into decoder and D/A output register.
1	A _{O1}	8-bit resolution D/A converter output pins (After power-on, all channels are reset and DAC data 00h is output.)
2	A _{O2}	
3	A _{O3} (M62343 only)	
4	V _{CC}	Power supply voltage pin
5	GND	GND pin

Absolute Maximum Ratings

Item	Symbol	Rated Value	Unit
Power supply voltage	V_{CC}	-0.3 to 7.0	V
Input voltage	V_{in}	-0.3 to $V_{CC}+0.3 \leq 7.0$	V
Output voltage	V_O	-0.3 to $V_{CC}+0.3 \leq 7.0$	V
Internal power consumption	P_d	417 (P) / 272 (FP)	mW
Operating ambient temperature	T_{opr}	-20 to +85	°C
Storage temperature	T_{stg}	-40 to +125	°C

Electrical Characteristics

(Unless specified otherwise, $V_{CC} = +5\text{ V} \pm 10\%$, $GND = 0\text{ V}$, $T_a = -20^\circ\text{C}$ to 85°C)

Item	Symbol	Specification Values			Unit	Test Conditions
		Min	Typ	Max		
Power supply voltage	V_{CC}	2.7	5.0	5.5	V	
Power supply current	I_{CC}	0	0.7 (M62342) 0.8 (M62343)	2.5 (M62342) 2.7 (M62343)	mA	At CLK = 1 MHz operation, $I_{AO} = 0\ \mu\text{A}$ D/A data: 6 Ah (at maximum current)
		0	0.5 (M62342) 0.6 (M62343)	1.6 (M62342) 1.8 (M62343)		DI = CLK = LD = GND, $I_{AO} = 0\ \mu\text{A}$
Input leakage current	I_{ILK}	-10	—	10	μA	$V_{IN} = 0$ to V_{CC}
Input voltage "L"	V_{IL}	0	—	$0.2V_{CC}$	V	
Input voltage "H"	V_{IH}	$0.5V_{CC}$	—	V_{CC}	V	
Buffer amp output voltage range	V_{AO}	0.1	—	$V_{CC}-0.1$	V	$I_{AO} = \pm 100\ \mu\text{A}$
		0.2	—	$V_{CC}-0.2$		$I_{AO} = \pm 500\ \mu\text{A}$
Buffer amp output drive range	I_{AO}	-1.0	—	1.0	mA	Upper saturation voltage = 0.3 V Lower saturation voltage = 0.2 V
Differential nonlinearity error	S_{DL}	-1.0	—	1.0	LSB	$V_{CC} = 5.12\text{ V}$ (20 mV/LSB) No load ($I_{AO} = 0$)
Nonlinearity error	S_L	-1.5	—	1.5	LSB	
Zero point error	S_{ZERO}	-2.0	—	2.0	LSB	
Full-scale error	S_{FULL}	-2.0	—	2.0	LSB	
Oscillation limit output capacitance	C_O	—	—	0.1	μF	
Buffer amp output impedance	R_O	—	5.0	—	Ω	

AC Characteristics

(Unless specified otherwise, $V_{CC} = +5\text{ V} \pm 10\%$, $GND = 0\text{ V}$, $T_a = -20^\circ\text{C}$ to 85°C)

Item	Symbol	Specification Values			Unit	Test Conditions
		Min	Typ	Max		
Clock "L" pulse width	t_{CKL}	200	—		ns	
Clock "H" pulse width	t_{CKH}	200	—		ns	
Clock rise time	t_{CR}	—	—	200	ns	
Clock fall time	t_{CF}	—	—	200	ns	
Data setup time	t_{DCH}	30	—	—	ns	
Data hold time	t_{CHD}	60	—	—	ns	
Load setup time	t_{CHL}	200	—	—	ns	
Load hold time	t_{LDC}	100	—	—	ns	
Load "H" pulse width	t_{LDH}	100	—	—	ns	
D-A output settling time	t_{LDD}	—	—	300	μs	Until output reaches last 1/2 LSB

Timing Chart

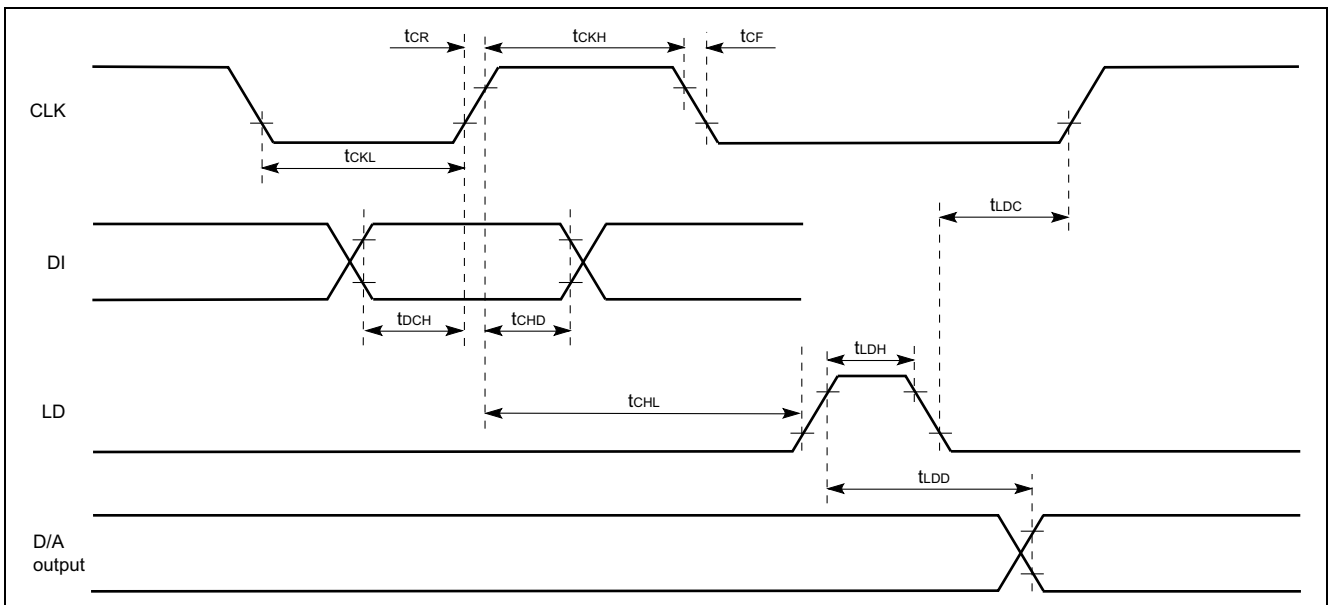

Digital Data Format

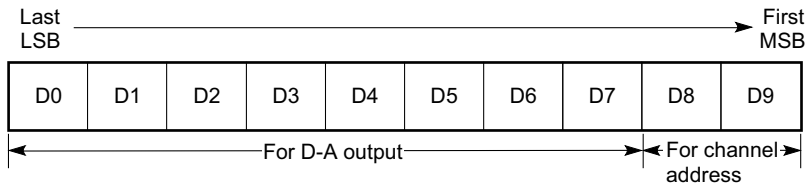

Channel Select Data

D8	D9	Channel Selection
0	0	AO1 selected
1	0	AO2 selected
0	1	M62343 : AO3 selected M62343 Don't care
1	1	Don't care

DAC Data

D0	D1	D2	D3	D4	D5	D6	D7	DAC output
0	0	0	0	0	0	0	0	$V_{CC}/256 \times 1$
1	0	0	0	0	0	0	0	$V_{CC}/256 \times 2$
0	1	0	0	0	0	0	0	$V_{CC}/256 \times 3$
1	1	0	0	0	0	0	0	$V_{CC}/256 \times 4$
⋮	⋮	⋮	⋮	⋮	⋮	⋮	⋮	⋮
0	1	1	1	1	1	1	1	$V_{CC}/256 \times 255$
1	1	1	1	1	1	1	1	$V_{CC}/256 \times 256$

Data Timing Chart (Model)

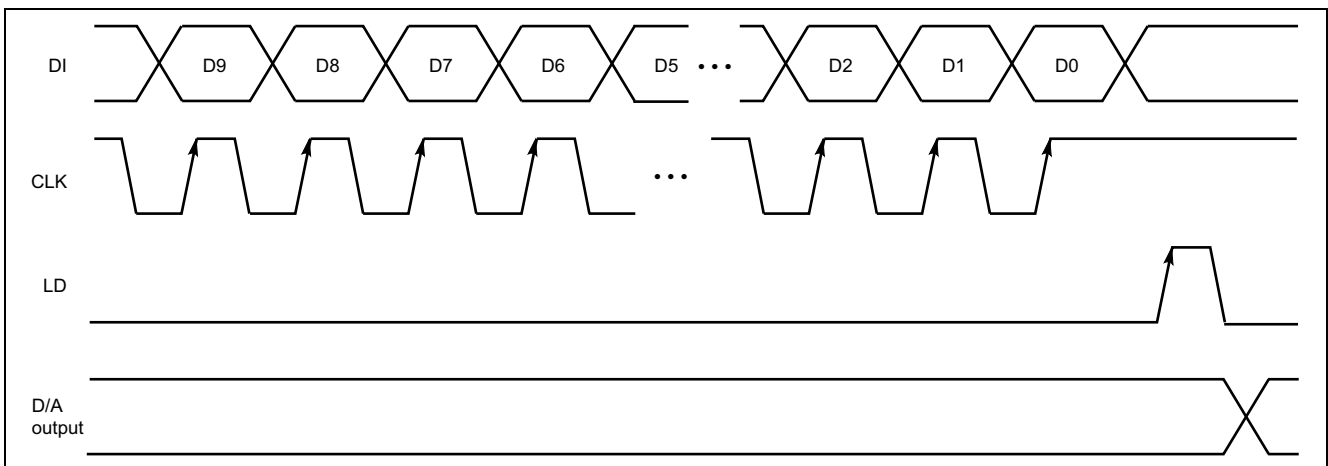

Usage Notes

1. With this IC, D/A converter upper reference voltage setting is performed by means of the power supply voltage. If ripples or spikes are imposed on this pin, conversion accuracy may fall. When using this IC, a capacitor must be inserted between the power supply pin and GND in order to ensure stable D/A conversion.
2. The output buffer amps of this IC are highly tolerant of capacitive loads. Therefore, connecting capacitors (0.1 μF max.) between the output pins and ground in order to eliminate jitter or noise due to output line wiring presents no problems whatever in terms of operation.

Sample Standard Application Circuit

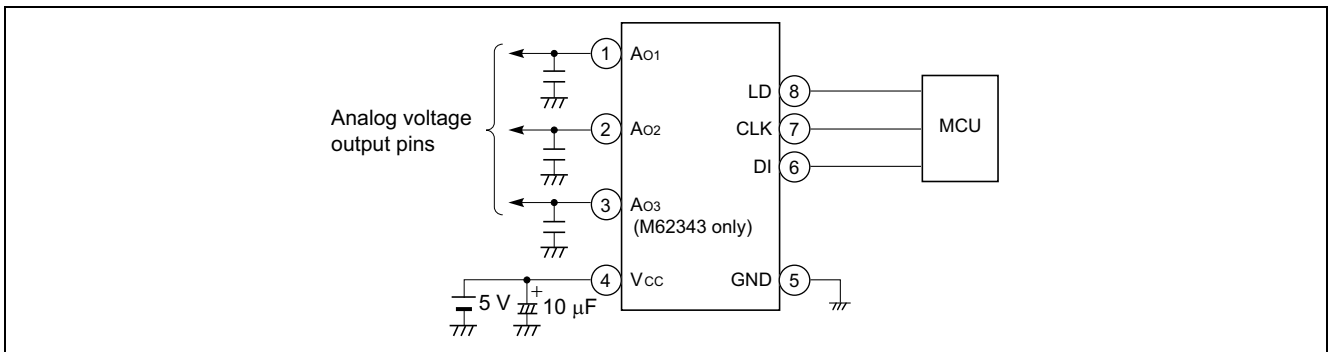

Package Dimensions

JEITA Package Code	RENESAS Code	Previous Code	MASS[Typ.]
P-DIP8-6.3x8.84-2.54	PRDP0008AA-A	8P4	0.5g

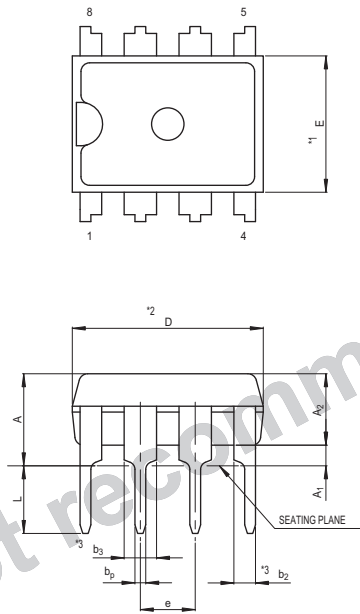

NOTE)
 1. DIMENSIONS "1" AND "2"
 DO NOT INCLUDE MOLD FLASH.
 2. DIMENSION "3" DOES NOT
 INCLUDE TRIM OFFSET.

Reference Symbol	Dimension in Millimeters		
	Min	Nom	Max
e1	7.32	7.62	7.92
D	8.7	8.9	9.1
E	6.15	6.3	6.45
A	—	—	4.5
A1	0.51	—	—
A2	—	3.3	—
bp	0.4	0.5	0.6
b2	0.9	1.0	1.3
b3	1.4	1.5	1.8
c	0.22	0.27	0.34
θ	0°	—	15°
e	2.29	2.54	2.79
L	3.0	—	—

JEITA Package Code	RENESAS Code	Previous Code	MASS[Typ.]
P-SOP8-4.4x4.85-1.27	PRSP0008DE-C	—	0.1g

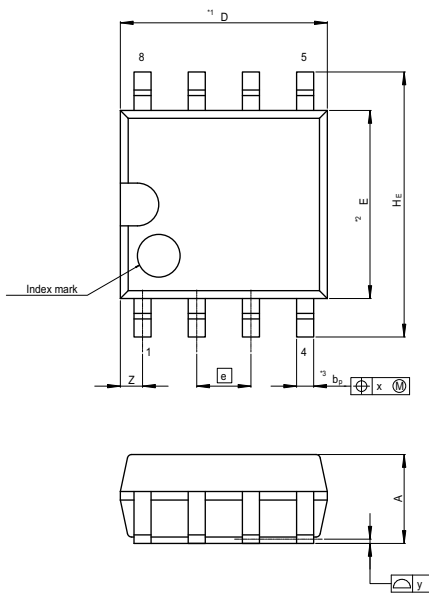

NOTE)
 1. DIMENSIONS "1" (Nom) AND "2"
 DO NOT INCLUDE MOLD FLASH.
 2. DIMENSION "3" DOES NOT
 INCLUDE TRIM OFFSET.

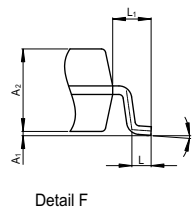
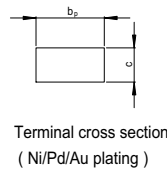

Reference Symbol	Dimension in Millimeters		
	Min	Nom	Max
D	4.65	4.85	5.05
E	4.2	4.4	4.6
A2	—	1.85	—
A1	0.00	0.1	0.20
A	—	—	2.03
bp	0.34	0.4	0.46
b1	—	—	—
c	0.15	0.20	0.25
c1	—	—	—
θ	0°	—	8°
HE	5.7	6.2	6.5
a	1.12	1.27	1.42
x	—	—	0.12
y	—	—	0.10
z	—	—	0.75
L	0.25	0.45	0.65
L1	—	0.90	—

M62342P/FP, M62343P/FP

JEITA Package Code	RENESAS Code	Previous Code	MASS[Typ.]
P-SOP8-4.4x5-1.27	PRSP0008DA-A	8P2S-A	0.07g

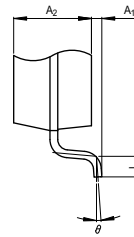
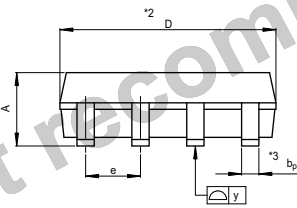
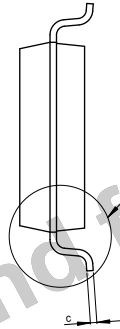
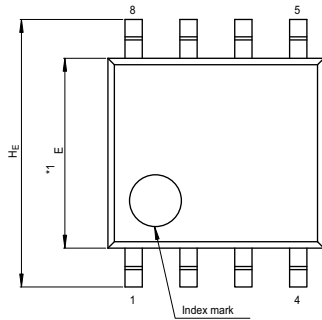

NOTE)
 1. DIMENSIONS **1* AND **2* DO NOT INCLUDE MOLD FLASH.
 2. DIMENSION **3* DOES NOT INCLUDE TRIM OFFSET.

Reference Symbol	Dimension in Millimeters		
	Min	Nom	Max
D	4.8	5.0	5.2
E	4.2	4.4	4.6
A ₂	—	1.5	—
A ₁	0.05	—	—
A	—	—	1.9
b _p	0.35	0.4	0.5
c	0.13	0.15	0.2
θ	0°	—	10°
H _E	5.9	6.2	6.5
e	1.12	1.27	1.42
y	—	—	0.1
L	0.2	0.4	0.6

Notice

- All information included in this document is current as of the date this document is issued. Such information, however, is subject to change without any prior notice. Before purchasing or using any Renesas Electronics products listed herein, please confirm the latest product information with a Renesas Electronics sales office. Also, please pay regular and careful attention to additional and different information to be disclosed by Renesas Electronics such as that disclosed through our website.
 - Renesas Electronics does not assume any liability for infringement of patents, copyrights, or other intellectual property rights of third parties by or arising from the use of Renesas Electronics products or technical information described in this document. No license, express, implied or otherwise, is granted hereby under any patents, copyrights or other intellectual property rights of Renesas Electronics or others.
 - You should not alter, modify, copy, or otherwise misappropriate any Renesas Electronics product, whether in whole or in part.
 - Descriptions of circuits, software and other related information in this document are provided only to illustrate the operation of semiconductor products and application examples. You are fully responsible for the incorporation of these circuits, software, and information in the design of your equipment. Renesas Electronics assumes no responsibility for any losses incurred by you or third parties arising from the use of these circuits, software, or information.
 - When exporting the products or technology described in this document, you should comply with the applicable export control laws and regulations and follow the procedures required by such laws and regulations. You should not use Renesas Electronics products or the technology described in this document for any purpose relating to military applications or use by the military, including but not limited to the development of weapons of mass destruction. Renesas Electronics products and technology may not be used for or incorporated into any products or systems whose manufacture, use, or sale is prohibited under any applicable domestic or foreign laws or regulations.
 - Renesas Electronics has used reasonable care in preparing the information included in this document, but Renesas Electronics does not warrant that such information is error free. Renesas Electronics assumes no liability whatsoever for any damages incurred by you resulting from errors in or omissions from the information included herein.
 - Renesas Electronics products are classified according to the following three quality grades: "Standard", "High Quality", and "Specific". The recommended applications for each Renesas Electronics product depends on the product's quality grade, as indicated below. You must check the quality grade of each Renesas Electronics product before using it in a particular application. You may not use any Renesas Electronics product for any application categorized as "Specific" without the prior written consent of Renesas Electronics. Further, you may not use any Renesas Electronics product for any application for which it is not intended without the prior written consent of Renesas Electronics. Renesas Electronics shall not be in any way liable for any damages or losses incurred by you or third parties arising from the use of any Renesas Electronics product for an application categorized as "Specific" or for which the product is not intended where you have failed to obtain the prior written consent of Renesas Electronics. The quality grade of each Renesas Electronics product is "Standard" unless otherwise expressly specified in a Renesas Electronics data sheets or data books, etc.
"Standard": Computers; office equipment; communications equipment; test and measurement equipment; audio and visual equipment; home electronic appliances; machine tools; personal electronic equipment; and industrial robots.
"High Quality": Transportation equipment (automobiles, trains, ships, etc.); traffic control systems; anti-disaster systems; anti-crime systems; safety equipment; and medical equipment not specifically designed for life support.
"Specific": Aircraft; aerospace equipment; submersible repeaters; nuclear reactor control systems; medical equipment or systems for life support (e.g. artificial life support devices or systems), surgical implantations, or healthcare intervention (e.g. excision, etc.), and any other applications or purposes that pose a direct threat to human life.
 - You should use the Renesas Electronics products described in this document within the range specified by Renesas Electronics, especially with respect to the maximum rating, operating supply voltage range, movement power voltage range, heat radiation characteristics, installation and other product characteristics. Renesas Electronics shall have no liability for malfunctions or damages arising out of the use of Renesas Electronics products beyond such specified ranges.
 - Although Renesas Electronics endeavors to improve the quality and reliability of its products, semiconductor products have specific characteristics such as the occurrence of failure at a certain rate and malfunctions under certain use conditions. Further, Renesas Electronics products are not subject to radiation resistance design. Please be sure to implement safety measures to guard them against the possibility of physical injury, and injury or damage caused by fire in the event of the failure of a Renesas Electronics product, such as safety design for hardware and software including but not limited to redundancy, fire control and malfunction prevention, appropriate treatment for aging degradation or any other appropriate measures. Because the evaluation of microcomputer software alone is very difficult, please evaluate the safety of the final products or system manufactured by you.
 - Please contact a Renesas Electronics sales office for details as to environmental matters such as the environmental compatibility of each Renesas Electronics product. Please use Renesas Electronics products in compliance with all applicable laws and regulations that regulate the inclusion or use of controlled substances, including without limitation, the EU RoHS Directive. Renesas Electronics assumes no liability for damages or losses occurring as a result of your noncompliance with applicable laws and regulations.
 - This document may not be reproduced or duplicated, in any form, in whole or in part, without prior written consent of Renesas Electronics.
 - Please contact a Renesas Electronics sales office if you have any questions regarding the information contained in this document or Renesas Electronics products, or if you have any other inquiries.
- (Note 1) "Renesas Electronics" as used in this document means Renesas Electronics Corporation and also includes its majority-owned subsidiaries.
- (Note 2) "Renesas Electronics product(s)" means any product developed or manufactured by or for Renesas Electronics.



SALES OFFICES

Renesas Electronics Corporation

<http://www.renesas.com>

Refer to "<http://www.renesas.com/>" for the latest and detailed information.

Renesas Electronics America Inc.
2880 Scott Boulevard Santa Clara, CA 95050-2554, U.S.A.
Tel: +1-408-586-6000, Fax: +1-408-588-6130

Renesas Electronics Canada Limited
1101 Nicholson Road, Newmarket, Ontario L3Y 9C3, Canada
Tel: +1-905-898-5441, Fax: +1-905-898-3220

Renesas Electronics Europe Limited
Dukes Meadow, Millboard Road, Bourne End, Buckinghamshire, SL8 5FH, U.K
Tel: +44-1628-585-100, Fax: +44-1628-585-900

Renesas Electronics Europe GmbH
Arcadiastrasse 10, 40472 Düsseldorf, Germany
Tel: +49-211-65030, Fax: +49-211-6503-1327

Renesas Electronics (China) Co., Ltd.
7th Floor, Quantum Plaza, No.27 ZhiChunLu Haidian District, Beijing 100083, P.R.China
Tel: +86-10-8235-1155, Fax: +86-10-8235-7679

Renesas Electronics (Shanghai) Co., Ltd.
Unit 204, 205, AZIA Center, No.1233 Lujiazui Ring Rd., Pudong District, Shanghai 200120, China
Tel: +86-21-5877-1818, Fax: +86-21-6887-7858 / -7898

Renesas Electronics Hong Kong Limited
Unit 1601-1613, 16/F., Tower 2, Grand Century Place, 193 Prince Edward Road West, Mongkok, Kowloon, Hong Kong
Tel: +852-2886-9318, Fax: +852 2886-9022/9044

Renesas Electronics Taiwan Co., Ltd.
13F, No. 363, Fu Shing North Road, Taipei, Taiwan
Tel: +886-2-8175-9600, Fax: +886 2-8175-9670

Renesas Electronics Singapore Pte. Ltd.
1 HarbourFront Avenue, #06-10, Keppel Bay Tower, Singapore 098632
Tel: +65-6213-0200, Fax: +65-6276-8001

Renesas Electronics Malaysia Sdn.Bhd.
Unit 906, Block B, Menara Amcorp, Amcorp Trade Centre, No. 18, Jin Persiaran Barat, 46050 Petaling Jaya, Selangor Darul Ehsan, Malaysia
Tel: +60-3-7955-9390, Fax: +60-3-7955-9510

Renesas Electronics Korea Co., Ltd.
11F., Samik Lavied' or Bldg., 720-2 Yeoksam-Dong, Kangnam-Ku, Seoul 135-080, Korea
Tel: +82-2-558-3737, Fax: +82-2-558-5141