

To our customers,

Old Company Name in Catalogs and Other Documents

On April 1st, 2010, NEC Electronics Corporation merged with Renesas Technology Corporation, and Renesas Electronics Corporation took over all the business of both companies. Therefore, although the old company name remains in this document, it is a valid Renesas Electronics document. We appreciate your understanding.

Renesas Electronics website: <http://www.renesas.com>

April 1st, 2010
Renesas Electronics Corporation

Issued by: Renesas Electronics Corporation (<http://www.renesas.com>)

Send any inquiries to <http://www.renesas.com/inquiry>.

The Renesas logo, featuring the word "RENESAS" in a bold, sans-serif font with a stylized square symbol to the left.

Notice

1. All information included in this document is current as of the date this document is issued. Such information, however, is subject to change without any prior notice. Before purchasing or using any Renesas Electronics products listed herein, please confirm the latest product information with a Renesas Electronics sales office. Also, please pay regular and careful attention to additional and different information to be disclosed by Renesas Electronics such as that disclosed through our website.
2. Renesas Electronics does not assume any liability for infringement of patents, copyrights, or other intellectual property rights of third parties by or arising from the use of Renesas Electronics products or technical information described in this document. No license, express, implied or otherwise, is granted hereby under any patents, copyrights or other intellectual property rights of Renesas Electronics or others.
3. You should not alter, modify, copy, or otherwise misappropriate any Renesas Electronics product, whether in whole or in part.
4. Descriptions of circuits, software and other related information in this document are provided only to illustrate the operation of semiconductor products and application examples. You are fully responsible for the incorporation of these circuits, software, and information in the design of your equipment. Renesas Electronics assumes no responsibility for any losses incurred by you or third parties arising from the use of these circuits, software, or information.
5. When exporting the products or technology described in this document, you should comply with the applicable export control laws and regulations and follow the procedures required by such laws and regulations. You should not use Renesas Electronics products or the technology described in this document for any purpose relating to military applications or use by the military, including but not limited to the development of weapons of mass destruction. Renesas Electronics products and technology may not be used for or incorporated into any products or systems whose manufacture, use, or sale is prohibited under any applicable domestic or foreign laws or regulations.
6. Renesas Electronics has used reasonable care in preparing the information included in this document, but Renesas Electronics does not warrant that such information is error free. Renesas Electronics assumes no liability whatsoever for any damages incurred by you resulting from errors in or omissions from the information included herein.
7. Renesas Electronics products are classified according to the following three quality grades: “Standard”, “High Quality”, and “Specific”. The recommended applications for each Renesas Electronics product depends on the product’s quality grade, as indicated below. You must check the quality grade of each Renesas Electronics product before using it in a particular application. You may not use any Renesas Electronics product for any application categorized as “Specific” without the prior written consent of Renesas Electronics. Further, you may not use any Renesas Electronics product for any application for which it is not intended without the prior written consent of Renesas Electronics. Renesas Electronics shall not be in any way liable for any damages or losses incurred by you or third parties arising from the use of any Renesas Electronics product for an application categorized as “Specific” or for which the product is not intended where you have failed to obtain the prior written consent of Renesas Electronics. The quality grade of each Renesas Electronics product is “Standard” unless otherwise expressly specified in a Renesas Electronics data sheets or data books, etc.
 - “Standard”: Computers; office equipment; communications equipment; test and measurement equipment; audio and visual equipment; home electronic appliances; machine tools; personal electronic equipment; and industrial robots.
 - “High Quality”: Transportation equipment (automobiles, trains, ships, etc.); traffic control systems; anti-disaster systems; anti-crime systems; safety equipment; and medical equipment not specifically designed for life support.
 - “Specific”: Aircraft; aerospace equipment; submersible repeaters; nuclear reactor control systems; medical equipment or systems for life support (e.g. artificial life support devices or systems), surgical implantations, or healthcare intervention (e.g. excision, etc.), and any other applications or purposes that pose a direct threat to human life.
8. You should use the Renesas Electronics products described in this document within the range specified by Renesas Electronics, especially with respect to the maximum rating, operating supply voltage range, movement power voltage range, heat radiation characteristics, installation and other product characteristics. Renesas Electronics shall have no liability for malfunctions or damages arising out of the use of Renesas Electronics products beyond such specified ranges.
9. Although Renesas Electronics endeavors to improve the quality and reliability of its products, semiconductor products have specific characteristics such as the occurrence of failure at a certain rate and malfunctions under certain use conditions. Further, Renesas Electronics products are not subject to radiation resistance design. Please be sure to implement safety measures to guard them against the possibility of physical injury, and injury or damage caused by fire in the event of the failure of a Renesas Electronics product, such as safety design for hardware and software including but not limited to redundancy, fire control and malfunction prevention, appropriate treatment for aging degradation or any other appropriate measures. Because the evaluation of microcomputer software alone is very difficult, please evaluate the safety of the final products or system manufactured by you.
10. Please contact a Renesas Electronics sales office for details as to environmental matters such as the environmental compatibility of each Renesas Electronics product. Please use Renesas Electronics products in compliance with all applicable laws and regulations that regulate the inclusion or use of controlled substances, including without limitation, the EU RoHS Directive. Renesas Electronics assumes no liability for damages or losses occurring as a result of your noncompliance with applicable laws and regulations.
11. This document may not be reproduced or duplicated, in any form, in whole or in part, without prior written consent of Renesas Electronics.
12. Please contact a Renesas Electronics sales office if you have any questions regarding the information contained in this document or Renesas Electronics products, or if you have any other inquiries.

(Note 1) “Renesas Electronics” as used in this document means Renesas Electronics Corporation and also includes its majority-owned subsidiaries.

(Note 2) “Renesas Electronics product(s)” means any product developed or manufactured by or for Renesas Electronics.

M62354AGP

8-bit 6ch D/A Converter with Buffer Amplifiers

REJ03D0871-0201
Rev.2.01
Dec 27, 2007

Description

M62354A is a CMOS structured semiconductor integrated circuit integrating 6 channels of built-in D/A converters with high performance buffer operational amplifier for each channel output.

3-wire serial interface (DI, CLK, LD) method is used for the transfer format of digital data to allow connection with microcomputer with minimum wiring DO terminal is provided to allow cascading serial use.

Built-in buffer operational amplifiers are designed to operate or full swing in the whole voltage range from V_{CC} to GND for each input/output. And their higher stability for capacitive load perfectly fits in to the use for electronic volume (VCA) or the replacement for semi-variable resistor for tuning.

Features

- 12-bit serial data input (3 wire serial data transfer method, DI, CLK, LD)
- Corresponds to TTL input for digital input ($V_{INH} \geq 2\text{ V}$, $V_{INL} \leq 0.8\text{ V}$)
- R-2R + segment method high performance 6ch 8-bit D/A converters
- 6ch buffer operational amplifiers operating in the whole voltage range from V_{CC} to GND
- Buffer operational amplifiers with high oscillation stability for capacitive load

Application

Adjustment or control of industrial or home-use electronic equipments such as VTR camera, VTR set, TV, and CRT display.

Block Diagram

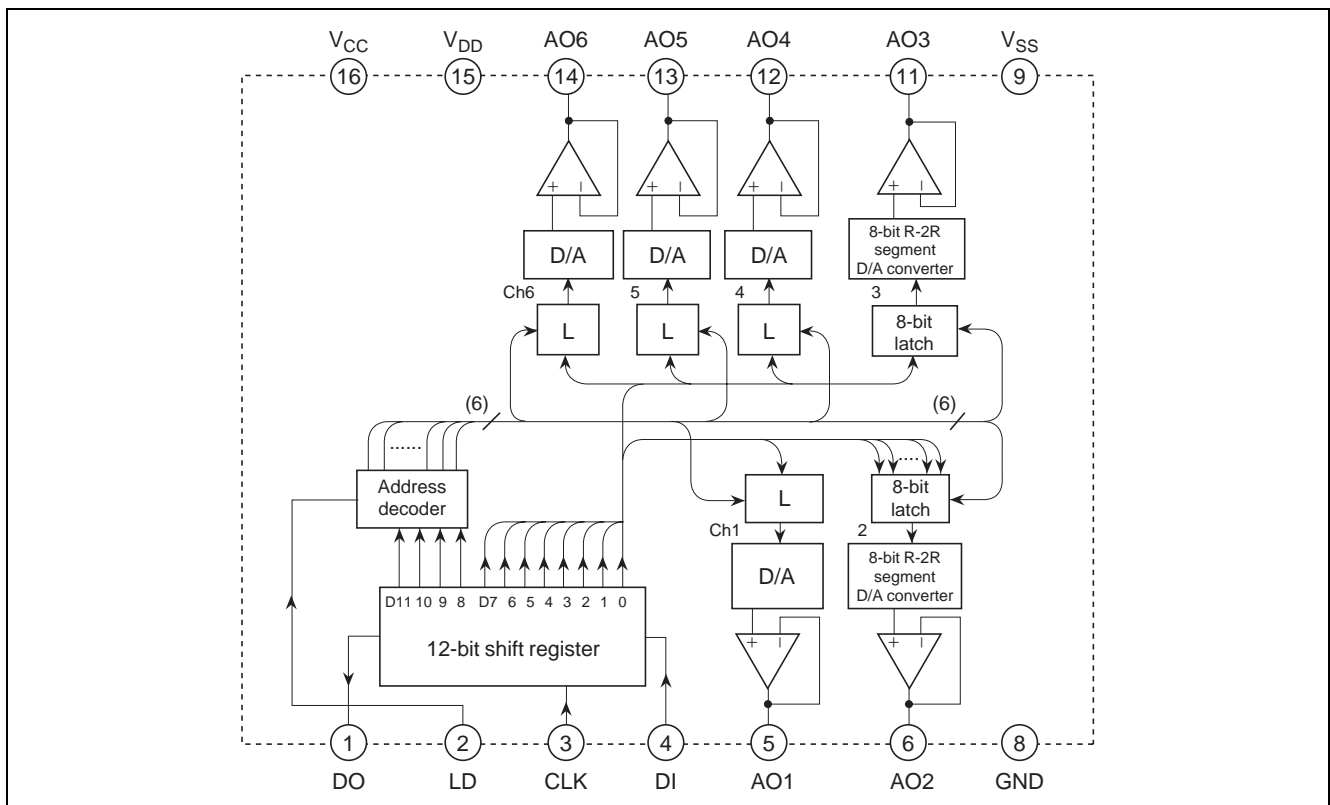

Pin Arrangement

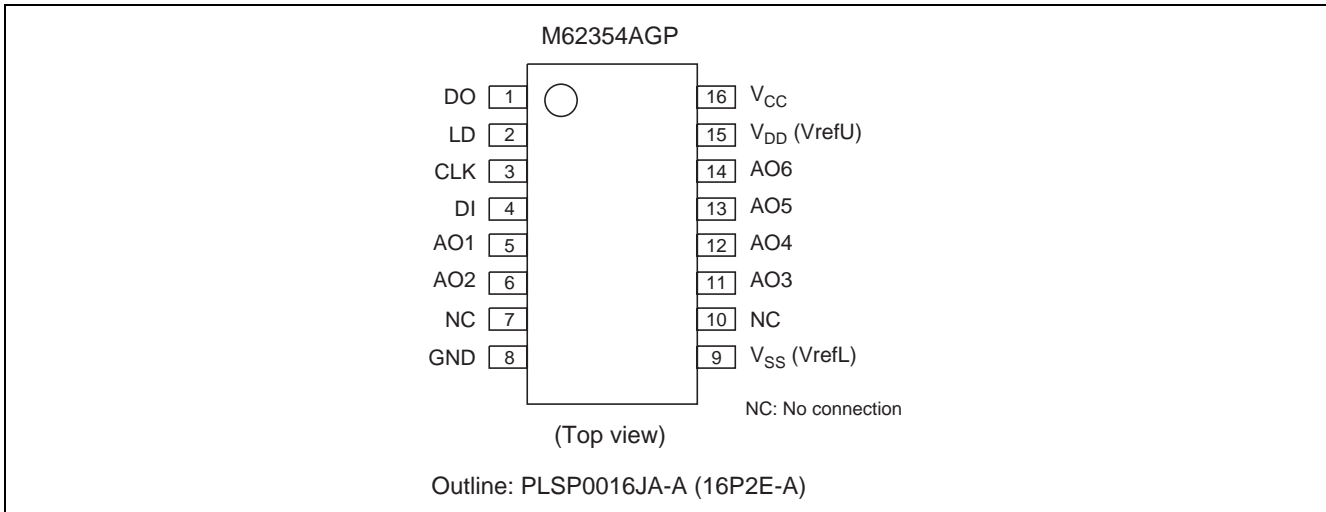

Pin Description

Pin No.	Pin Name	Function
4	DI	Serial data input terminal. 12-bit serial data is input to this terminal.
1	DO	Serial data output terminal. Serial data of 12-bit shift register is output from this terminal.
3	CLK	Serial clock input terminal. Input signal from DI terminal is input to 12-bit shift register upon the rise of shift clock.
2	LD	Data is loaded to register when "H" is input to LD terminal.
5	AO1	8-bit D/A converter output terminal. Built-in buffer amp. is connected to V_{CC} . D/A converted voltage between V_{DD} and V_{SS} is output to each terminal.
6	AO2	
11	AO3	
12	AO4	
13	AO5	
14	AO6	
16	V_{CC}	Power supply terminal.
8	GND	Digital and analog common GND
15	V_{DD}	D/A converter High level reference voltage input terminal.
9	V_{SS}	D/A converter Low level reference voltage input terminal.

Block Diagram for Explanation of Terminals

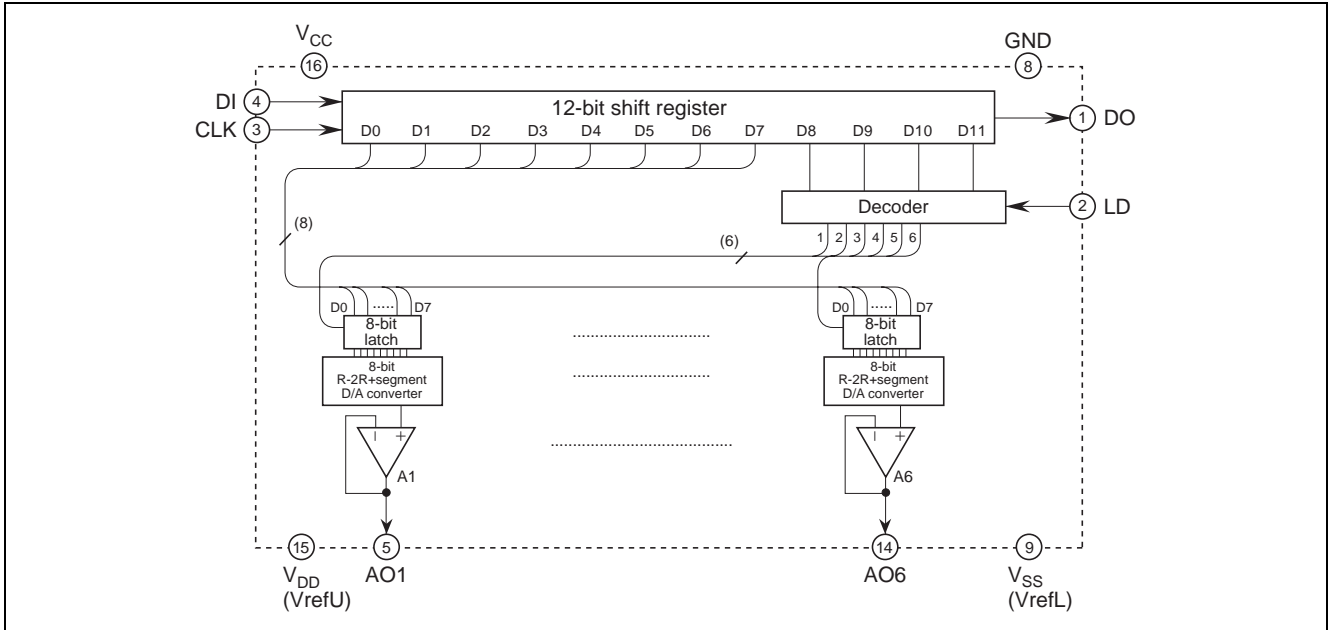

Absolute Maximum Ratings

Item	Symbol	Ratings	Unit
Supply voltage	V _{CC}	-0.3 to +7.0	V
D/A converter High level reference voltage	V _{DD}	-0.3 to +7.0	V
Digital input voltage	V _{IN}	-0.3 to V _{CC} + 0.3	V
Output voltage	V _{out}	-0.3 to V _{CC} + 0.3	V
Power dissipation	P _d	150	mW
Operating temperature	T _{opr}	-20 to +85	°C
Storage temperature	T _{stg}	-40 to +125	°C

Electrical Characteristics

<Digital Part>

(V_{CC} , $V_{refU} = 5\text{ V} \pm 10\%$, $V_{CC} \geq V_{refU}$, GND, $V_{refL} = 0.0\text{ V}$, $T_a = -20$ to $+85^\circ\text{C}$ unless otherwise specified.)

Item	Symbol	Limits			Unit	Conditions
		Min	Typ	Max		
Supply voltage	V_{CC}	4.5	5.0	5.5	V	
Supply current	I_{CC}	—	0.7	2.5	mA	CLK = 1 MHz operation $V_{CC} = 5\text{ V}$, $I_{AO} = 0\text{ }\mu\text{A}$
Input leak current	I_{ILK}	-10	—	10	μA	$V_{IN} = 0$ to V_{CC}
Digital input Low voltage	V_{IL}	—	—	0.8	V	
Digital input High voltage	V_{IH}	2.0	—	—	V	
Digital output Low voltage	V_{OL}	—	—	0.4	V	$I_{OL} = 2.5\text{ mA}$
Digital output High voltage	V_{OH}	$V_{CC} - 0.4$	—	—	V	$I_{OH} = -400\text{ }\mu\text{A}$

Note: Typical value is for $T_a = 25^\circ\text{C}$

Changes from M62354GP: Digital input voltage corresponds to TTL spec.

<Analog Part>

(V_{CC} , $V_{refU} = 5\text{ V} \pm 10\%$, $V_{CC} \geq V_{refU}$, GND, $V_{refL} = 0.0\text{ V}$, $T_a = -20$ to $+85^\circ\text{C}$ unless otherwise specified.)

Item	Symbol	Limits			Unit	Conditions
		Min	Typ	Max		
Reference voltage pin current	I_{refU}	—	0.7	1.3	mA	$V_{refU} = 5\text{ V}$, $V_{refL} = 0\text{ V}$, $I_{AO} = 0\text{ }\mu\text{A}$ Data condition: at maximum current
D/A converter High level reference voltage range	V_{DD} (V_{refU})	3.5	—	V_{CC}	V	The output does not necessarily be the Values within the reference voltage setting range. The output value is determined by the buffer amplifier output voltage range (V_{AO}).
D/A converter Low level reference voltage range	V_{SS} (V_{refL})	GND	—	$V_{CC} - 3.5$	V	
Buffer amplifier output drive range	V_{AO}	0.1	—	$V_{CC} - 0.1$	V	$I_{AO} = \pm 100\text{ }\mu\text{A}$
		0.2	—	$V_{CC} - 0.2$		$I_{AO} = \pm 500\text{ }\mu\text{A}$
Buffer amplifier output drive range	I_{AO}	-1	—	1	mA	Upper side saturation voltage = 0.3 V Lower side saturation voltage = 0.2 V
Differential nonlinearity	S_{DL}	-1.0	—	1.0	LSB	$V_{refU} = 4.79\text{ V}$
Nonlinearity	S_L	-1.5	—	1.5	LSB	$V_{refL} = 0.95\text{ V}$ (15 mV/LSB)
Zero code error	S_{ZERO}	-2.0	—	2.0	LSB	$V_{CC} = 5.5\text{ V}$
Full scale error	S_{FULL}	-2.0	—	2.0	LSB	Without load ($I_{AO} = +0\text{ }\mu\text{A}$)
Output capacitive load	C_O	—	—	0.1	μF	
Buffer Amp. output impedance	R_O	—	5	—	Ω	

AC Characteristics

(V_{CC} , $V_{refU} = 5\text{ V} \pm 10\%$, $V_{CC} \geq V_{refU}$, GND , $V_{refL} = 0.0\text{ V}$, $T_a = -20\text{ to }+85^\circ\text{C}$ unless otherwise specified.)

Item	Symbol	Limits			Unit	Conditions
		Min	Typ	Max		
Clock "L" pulse width	t_{CKL}	200	—	—	ns	
Clock "H" pulse width	t_{CKH}	200	—	—	ns	
Clock rise time	t_{CR}	—	—	200	ns	
Clock fall time	t_{CF}					
Data setup time	t_{DCH}	30	—	—	ns	
Data hold time	t_{CHD}	60	—	—	ns	
LD setup time	t_{CHL}	200	—	—	ns	
LD hold time	t_{LDC}	100	—	—	ns	
LD "H" hold time	t_{LDH}	100	—	—	ns	
Data output delay time	t_{DO}	70	—	350	ns	$C_L \leq 100\text{ pF}$
D/A output setting time	t_{LDD}	—	—	300	μs	$C_L \leq 100\text{ pF}$, $V_{AO}: 0.5 \leftrightarrow 4.5\text{ V}$ The time until the output becomes the final value of 1/2 LSB

Measurement Circuit

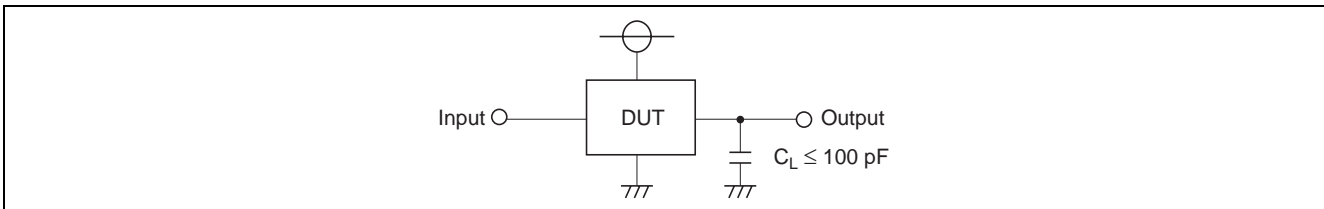

Timing Chart

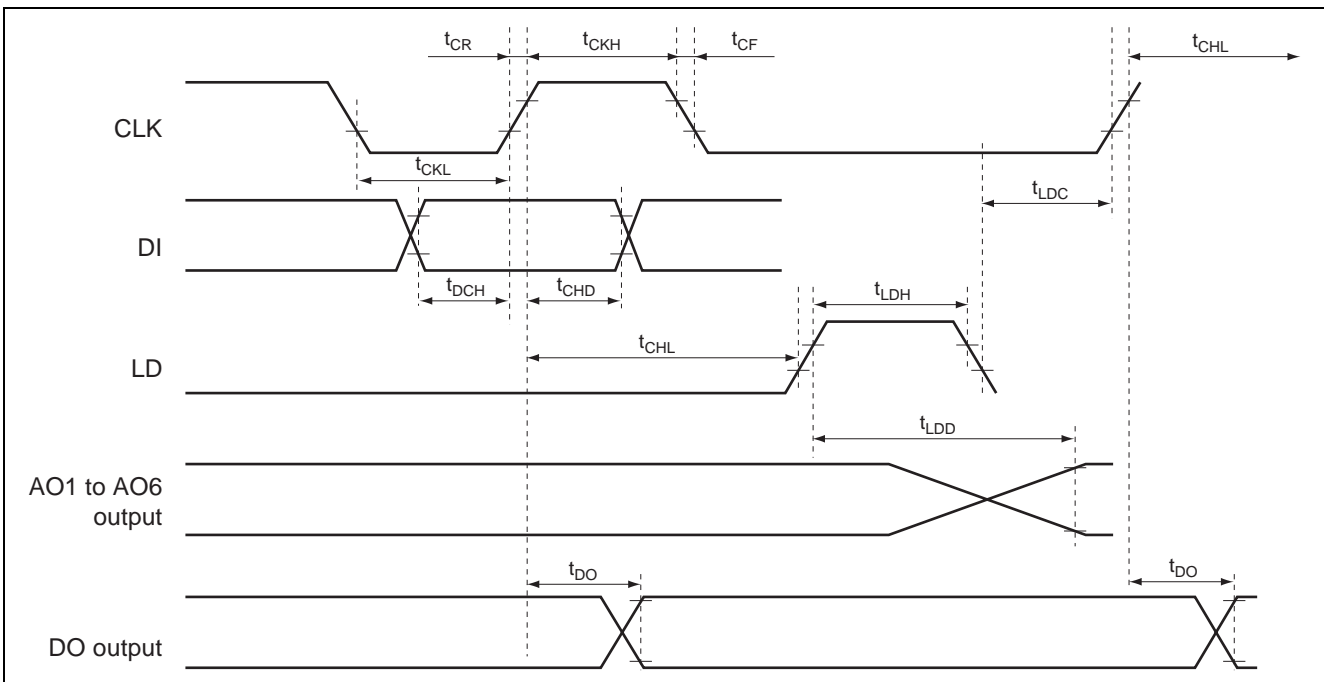

Digital Data Format

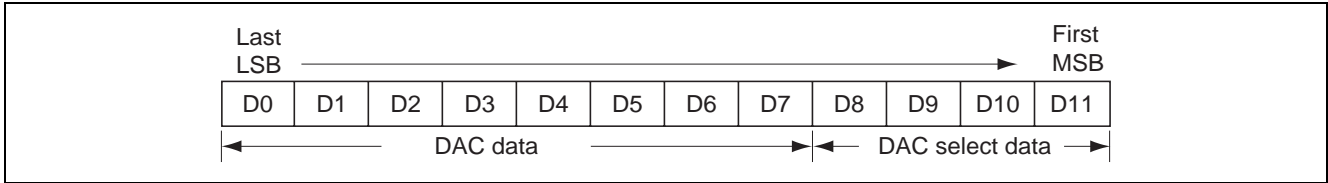

DAC Data

D0	D1	D2	D3	D4	D5	D6	D7	D/A Output	
0	0	0	0	0	0	0	0	$(V_{refU} - V_{refL}) / 256 \times 1 + V_{refL}$ [V]	(1 LSB)
1	0	0	0	0	0	0	0	$(V_{refU} - V_{refL}) / 256 \times 2 + V_{refL}$ [V]	(2 LSB)
0	1	0	0	0	0	0	0	$(V_{refU} - V_{refL}) / 256 \times 3 + V_{refL}$ [V]	(3 LSB)
1	1	0	0	0	0	0	0	$(V_{refU} - V_{refL}) / 256 \times 4 + V_{refL}$ [V]	(4 LSB)
:	:	:	:	:	:	:	:	:	:
0	1	1	1	1	1	1	1	$(V_{refU} - V_{refL}) / 256 \times 255 + V_{refL}$ [V]	(255 LSB)
1	1	1	1	1	1	1	1	V_{refU} [V]	(256 LSB)

Note: $V_{refU} = V_{DD}$, $V_{refL} = V_{SS}$

DAC Select Data

D8	D9	D10	D11	DAC Selection
0	0	0	0	Don't care
0	0	0	1	AO1 select
0	0	1	0	AO2 select
0	0	1	1	AO3 select
0	1	0	0	AO4 select
0	1	0	1	AO5 select
0	1	1	0	AO6 select
0	1	1	1	Don't care
1	0	0	0	Don't care
1	0	0	1	Don't care
1	0	1	0	Don't care
1	0	1	1	Don't care
1	1	0	0	Don't care
1	1	0	1	Don't care
1	1	1	0	Don't care
1	1	1	1	Don't care

Timing Chart (Model)

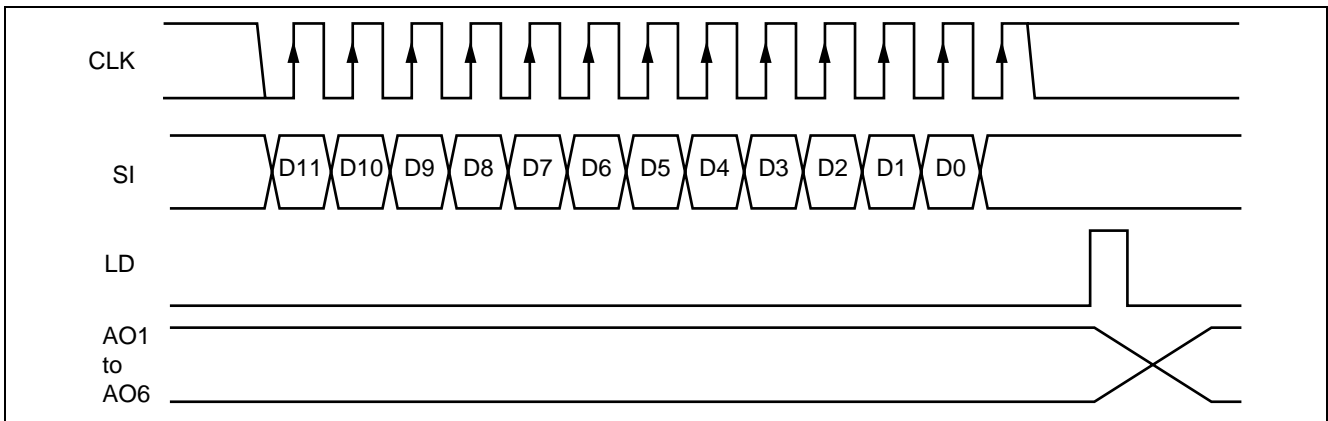

Typical Application

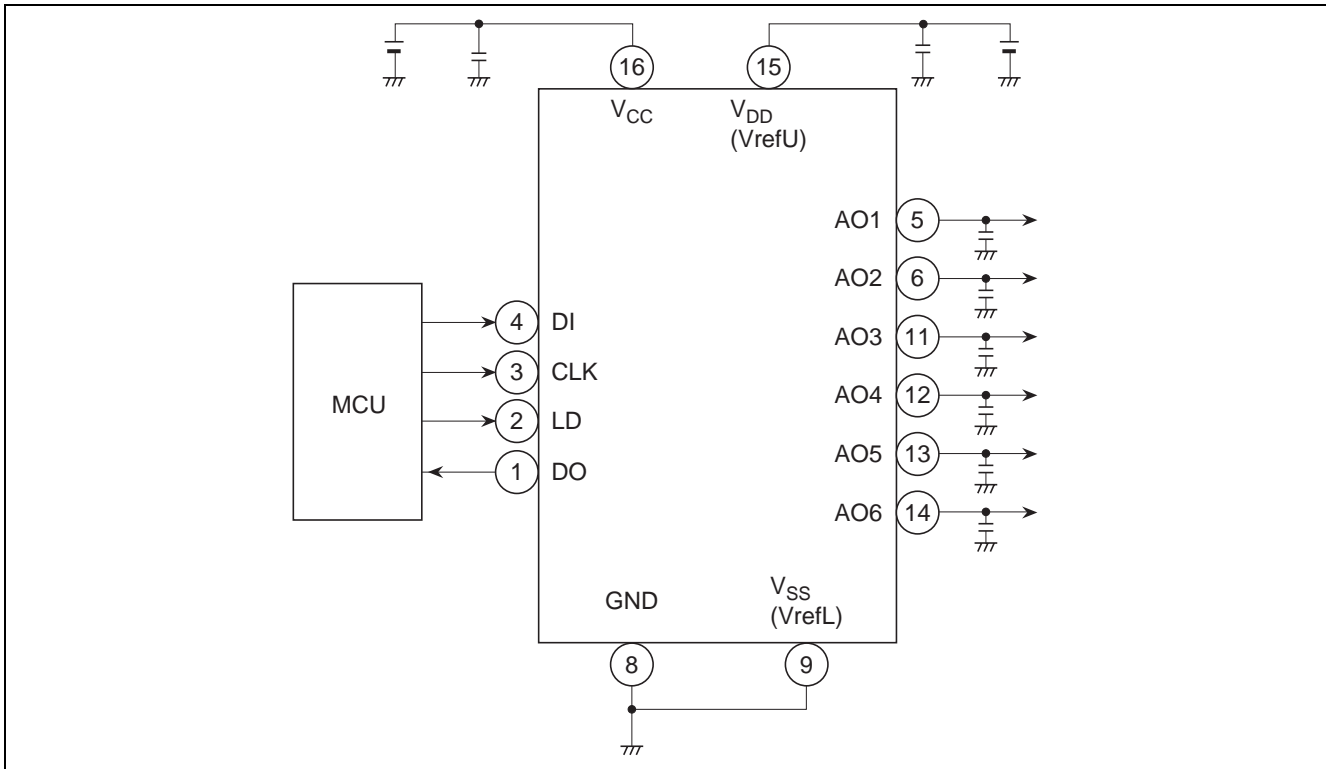

Precaution for Use

M62354AGP has 3 terminals (V_{DD} , V_{CC} , and V_{SS}) to which constant voltage is to be applied. Ripple voltage or spike noise to these terminals may worsen converting precision or cause erroneous operations. So be sure to use this device by putting capacitor between each terminal and GND to get D/A conversion operation stabilized.

Output buffer amplifiers have high oscillation stability against capacitive load. This means that jitters by wirings around output terminals or capacitor between output and GND (0.1 μF Max) do not cause any problems with DAC operations.

Connect capacitor (0.1 μF or around) between output and GND for protection from spark discharge when this device is used under such high electric field as that for instance of instruments with cathode ray tube.

Package Dimensions

JEITA Package Code	RENESAS Code	Previous Code	MASS[Typ.]
P-LSSOP16-4.4x5-0.65	PLSP0016JA-A	16P2E-A	0.06g

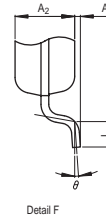
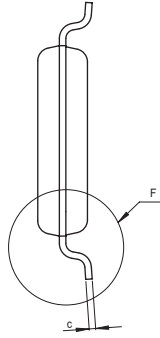
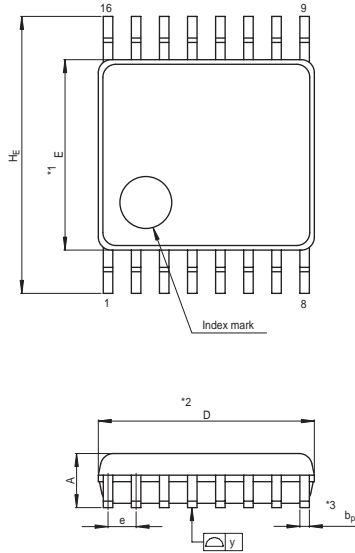

NOTE)
 1. DIMENSIONS **1* AND **2* DO NOT INCLUDE MOLD FLASH.
 2. DIMENSION **3* DOES NOT INCLUDE TRIM OFFSET.

Reference Symbol	Dimension in Millimeters		
	Min	Nom	Max
D	4.9	5.0	5.1
E	4.3	4.4	4.5
A ₂	—	1.15	—
A	—	—	1.45
A ₁	0	0.1	0.2
b _p	0.17	0.22	0.32
c	0.13	0.15	0.2
θ	0°	—	10°
H _E	6.2	6.4	6.6
e	0.53	0.65	0.77
y	—	—	0.10
L	0.3	0.5	0.7

Notes:

1. This document is provided for reference purposes only so that Renesas customers may select the appropriate Renesas products for their use. Renesas neither makes warranties or representations with respect to the accuracy or completeness of the information contained in this document nor grants any license to any intellectual property rights or any other rights of Renesas or any third party with respect to the information in this document.
2. Renesas shall have no liability for damages or infringement of any intellectual property or other rights arising out of the use of any information in this document, including, but not limited to, product data, diagrams, charts, programs, algorithms, and application circuit examples.
3. You should not use the products or the technology described in this document for the purpose of military applications such as the development of weapons of mass destruction or for the purpose of any other military use. When exporting the products or technology described herein, you should follow the applicable export control laws and regulations, and procedures required by such laws and regulations.
4. All information included in this document such as product data, diagrams, charts, programs, algorithms, and application circuit examples, is current as of the date this document is issued. Such information, however, is subject to change without any prior notice. Before purchasing or using any Renesas products listed in this document, please confirm the latest product information with a Renesas sales office. Also, please pay regular and careful attention to additional and different information to be disclosed by Renesas such as that disclosed through our website. (<http://www.renesas.com>)
5. Renesas has used reasonable care in compiling the information included in this document, but Renesas assumes no liability whatsoever for any damages incurred as a result of errors or omissions in the information included in this document.
6. When using or otherwise relying on the information in this document, you should evaluate the information in light of the total system before deciding about the applicability of such information to the intended application. Renesas makes no representations, warranties or guaranties regarding the suitability of its products for any particular application and specifically disclaims any liability arising out of the application and use of the information in this document or Renesas products.
7. With the exception of products specified by Renesas as suitable for automobile applications, Renesas products are not designed, manufactured or tested for applications or otherwise in systems the failure or malfunction of which may cause a direct threat to human life or create a risk of human injury or which require especially high quality and reliability such as safety systems, or equipment or systems for transportation and traffic, healthcare, combustion control, aerospace and aeronautics, nuclear power, or undersea communication transmission. If you are considering the use of our products for such purposes, please contact a Renesas sales office beforehand. Renesas shall have no liability for damages arising out of the uses set forth above.
8. Notwithstanding the preceding paragraph, you should not use Renesas products for the purposes listed below:
 - (1) artificial life support devices or systems
 - (2) surgical implantations
 - (3) healthcare intervention (e.g., excision, administration of medication, etc.)
 - (4) any other purposes that pose a direct threat to human lifeRenesas shall have no liability for damages arising out of the uses set forth in the above and purchasers who elect to use Renesas products in any of the foregoing applications shall indemnify and hold harmless Renesas Technology Corp., its affiliated companies and their officers, directors, and employees against any and all damages arising out of such applications.
9. You should use the products described herein within the range specified by Renesas, especially with respect to the maximum rating, operating supply voltage range, movement power voltage range, heat radiation characteristics, installation and other product characteristics. Renesas shall have no liability for malfunctions or damages arising out of the use of Renesas products beyond such specified ranges.
10. Although Renesas endeavors to improve the quality and reliability of its products, IC products have specific characteristics such as the occurrence of failure at a certain rate and malfunctions under certain use conditions. Please be sure to implement safety measures to guard against the possibility of physical injury, and injury or damage caused by fire in the event of the failure of a Renesas product, such as safety design for hardware and software including but not limited to redundancy, fire control and malfunction prevention, appropriate treatment for aging degradation or any other applicable measures. Among others, since the evaluation of microcomputer software alone is very difficult, please evaluate the safety of the final products or system manufactured by you.
11. In case Renesas products listed in this document are detached from the products to which the Renesas products are attached or affixed, the risk of accident such as swallowing by infants and small children is very high. You should implement safety measures so that Renesas products may not be easily detached from your products. Renesas shall have no liability for damages arising out of such detachment.
12. This document may not be reproduced or duplicated, in any form, in whole or in part, without prior written approval from Renesas.
13. Please contact a Renesas sales office if you have any questions regarding the information contained in this document, Renesas semiconductor products, or if you have any other inquiries.



RENESAS SALES OFFICES

<http://www.renesas.com>

Refer to "<http://www.renesas.com/en/network>" for the latest and detailed information.

Renesas Technology America, Inc.
450 Holger Way, San Jose, CA 95134-1368, U.S.A
Tel: <1> (408) 382-7500, Fax: <1> (408) 382-7501

Renesas Technology Europe Limited
Dukes Meadow, Millboard Road, Bourne End, Buckinghamshire, SL8 5FH, U.K.
Tel: <44> (1628) 585-100, Fax: <44> (1628) 585-900

Renesas Technology (Shanghai) Co., Ltd.
Unit 204, 205, AZIA Center, No.1233 Lujiazui Ring Rd, Pudong District, Shanghai, China 200120
Tel: <86> (21) 5877-1818, Fax: <86> (21) 6887-7858/7898

Renesas Technology Hong Kong Ltd.
7th Floor, North Tower, World Finance Centre, Harbour City, Canton Road, Tsimshatsui, Kowloon, Hong Kong
Tel: <852> 2265-6688, Fax: <852> 2377-3473

Renesas Technology Taiwan Co., Ltd.
10th Floor, No.99, Fushing North Road, Taipei, Taiwan
Tel: <886> (2) 2715-2888, Fax: <886> (2) 3518-3399

Renesas Technology Singapore Pte. Ltd.
1 Harbour Front Avenue, #06-10, Keppel Bay Tower, Singapore 098632
Tel: <65> 6213-0200, Fax: <65> 6278-8001

Renesas Technology Korea Co., Ltd.
Kukje Center Bldg. 18th Fl., 191, 2-ka, Hangang-ro, Yongsan-ku, Seoul 140-702, Korea
Tel: <82> (2) 796-3115, Fax: <82> (2) 796-2145

Renesas Technology Malaysia Sdn. Bhd
Unit 906, Block B, Menara Amcorp, Amcorp Trade Centre, No.18, Jln Persiaran Barat, 46050 Petaling Jaya, Selangor Darul Ehsan, Malaysia
Tel: <603> 7955-9390, Fax: <603> 7955-9510