

To our customers,

Old Company Name in Catalogs and Other Documents

On April 1st, 2010, NEC Electronics Corporation merged with Renesas Technology Corporation, and Renesas Electronics Corporation took over all the business of both companies. Therefore, although the old company name remains in this document, it is a valid Renesas Electronics document. We appreciate your understanding.

Renesas Electronics website: <http://www.renesas.com>

April 1st, 2010
Renesas Electronics Corporation

Issued by: Renesas Electronics Corporation (<http://www.renesas.com>)

Send any inquiries to <http://www.renesas.com/inquiry>.

Not recommended
for new design



Notice

1. All information included in this document is current as of the date this document is issued. Such information, however, is subject to change without any prior notice. Before purchasing or using any Renesas Electronics products listed herein, please confirm the latest product information with a Renesas Electronics sales office. Also, please pay regular and careful attention to additional and different information to be disclosed by Renesas Electronics such as that disclosed through our website.
2. Renesas Electronics does not assume any liability for infringement of patents, copyrights, or other intellectual property rights of third parties by or arising from the use of Renesas Electronics products or technical information described in this document. No license, express, implied or otherwise, is granted hereby under any patents, copyrights or other intellectual property rights of Renesas Electronics or others.
3. You should not alter, modify, copy, or otherwise misappropriate any Renesas Electronics product, whether in whole or in part.
4. Descriptions of circuits, software and other related information in this document are provided only to illustrate the operation of semiconductor products and application examples. You are fully responsible for the incorporation of these circuits, software, and information in the design of your equipment. Renesas Electronics assumes no responsibility for any losses incurred by you or third parties arising from the use of these circuits, software, or information.
5. When exporting the products or technology described in this document, you should comply with the applicable export control laws and regulations and follow the procedures required by such laws and regulations. You should not use Renesas Electronics products or the technology described in this document for any purpose relating to military applications or use by the military, including but not limited to the development of weapons of mass destruction. Renesas Electronics products and technology may not be used for or incorporated into any products or systems whose manufacture, use, or sale is prohibited under any applicable domestic or foreign laws or regulations.
6. Renesas Electronics has used reasonable care in preparing the information included in this document, but Renesas Electronics does not warrant that such information is error free. Renesas Electronics assumes no liability whatsoever for any damages incurred by you resulting from errors in or omissions from the information included herein.
7. Renesas Electronics products are classified according to the following three quality grades: “Standard”, “High Quality”, and “Specific”. The recommended applications for each Renesas Electronics product depends on the product’s quality grade, as indicated below. You must check the quality grade of each Renesas Electronics product before using it in a particular application. You may not use any Renesas Electronics product for any application categorized as “Specific” without the prior written consent of Renesas Electronics. Further, you may not use any Renesas Electronics product for any application for which it is not intended without the prior written consent of Renesas Electronics. Renesas Electronics shall not be in any way liable for any damages or losses incurred by you or third parties arising from the use of any Renesas Electronics product for an application categorized as “Specific” or for which the product is not intended where you have failed to obtain the prior written consent of Renesas Electronics. The quality grade of each Renesas Electronics product is “Standard” unless otherwise expressly specified in a Renesas Electronics data sheets or data books, etc.
 - “Standard”: Computers; office equipment; communications equipment; test and measurement equipment; audio and visual equipment; home electronic appliances; machine tools; personal electronic equipment; and industrial robots.
 - “High Quality”: Transportation equipment (automobiles, trains, ships, etc.); traffic control systems; anti-disaster systems; anti-crime systems; safety equipment; and medical equipment not specifically designed for life support.
 - “Specific”: Aircraft; aerospace equipment; submersible repeaters; nuclear reactor control systems; medical equipment or systems for life support (e.g. artificial life support devices or systems), surgical implantations, or healthcare intervention (e.g. excision, etc.), and any other applications or purposes that pose a direct threat to human life.
8. You should use the Renesas Electronics products described in this document within the range specified by Renesas Electronics, especially with respect to the maximum rating, operating supply voltage range, movement power voltage range, heat radiation characteristics, installation and other product characteristics. Renesas Electronics shall have no liability for malfunctions or damages arising out of the use of Renesas Electronics products beyond such specified ranges.
9. Although Renesas Electronics endeavors to improve the quality and reliability of its products, semiconductor products have specific characteristics such as the occurrence of failure at a certain rate and malfunctions under certain use conditions. Further, Renesas Electronics products are not subject to radiation resistance design. Please be sure to implement safety measures to guard them against the possibility of physical injury, and injury or damage caused by fire in the event of the failure of a Renesas Electronics product, such as safety design for hardware and software including but not limited to redundancy, fire control and malfunction prevention, appropriate treatment for aging degradation or any other appropriate measures. Because the evaluation of microcomputer software alone is very difficult, please evaluate the safety of the final products or system manufactured by you.
10. Please contact a Renesas Electronics sales office for details as to environmental matters such as the environmental compatibility of each Renesas Electronics product. Please use Renesas Electronics products in compliance with all applicable laws and regulations that regulate the inclusion or use of controlled substances, including without limitation, the EU RoHS Directive. Renesas Electronics assumes no liability for damages or losses occurring as a result of your noncompliance with applicable laws and regulations.
11. This document may not be reproduced or duplicated, in any form, in whole or in part, without prior written consent of Renesas Electronics.
12. Please contact a Renesas Electronics sales office if you have any questions regarding the information contained in this document or Renesas Electronics products, or if you have any other inquiries.

(Note 1) “Renesas Electronics” as used in this document means Renesas Electronics Corporation and also includes its majority-owned subsidiaries.

(Note 2) “Renesas Electronics product(s)” means any product developed or manufactured by or for Renesas Electronics.

DATA SHEET

RENESAS

MOS INTEGRATED CIRCUIT μ PD4721

RS-232 LINE DRIVER/RECEIVER AT 3.3 V/5 V

The μ PD4721 is a high-breakdown voltage silicon gate CMOS line driver/receiver based on the EIA/TIA-232-E standard. The internal DC/DC converter can switch between multiple voltages, realizing the allowing it to operate with a single +3.3 V or +5 V power supply. It also provides standby function.

This IC incorporates 2 driver circuits and 2 receiver circuits. An RS-232 interface circuit can be easily configured by connecting 5 capacitors externally.

FEATURES

- Conforms to EIA/TIA-232-E (former name, RS-232C) standards
- Selectable +3.3 V/+5 V single power supply (selected by V_{CHA} pin)
- By setting the standby pin to a low level (standby mode), circuit current can be reduced. At such times, the driver output is in a high-impedance state.

ORDERING INFORMATION

Part number	Package
μ PD4721GS-GJG	20-pin plastic SSOP (300 mil)

BLOCK DIAGRAM/PIN CONFIGURATION (Top View)

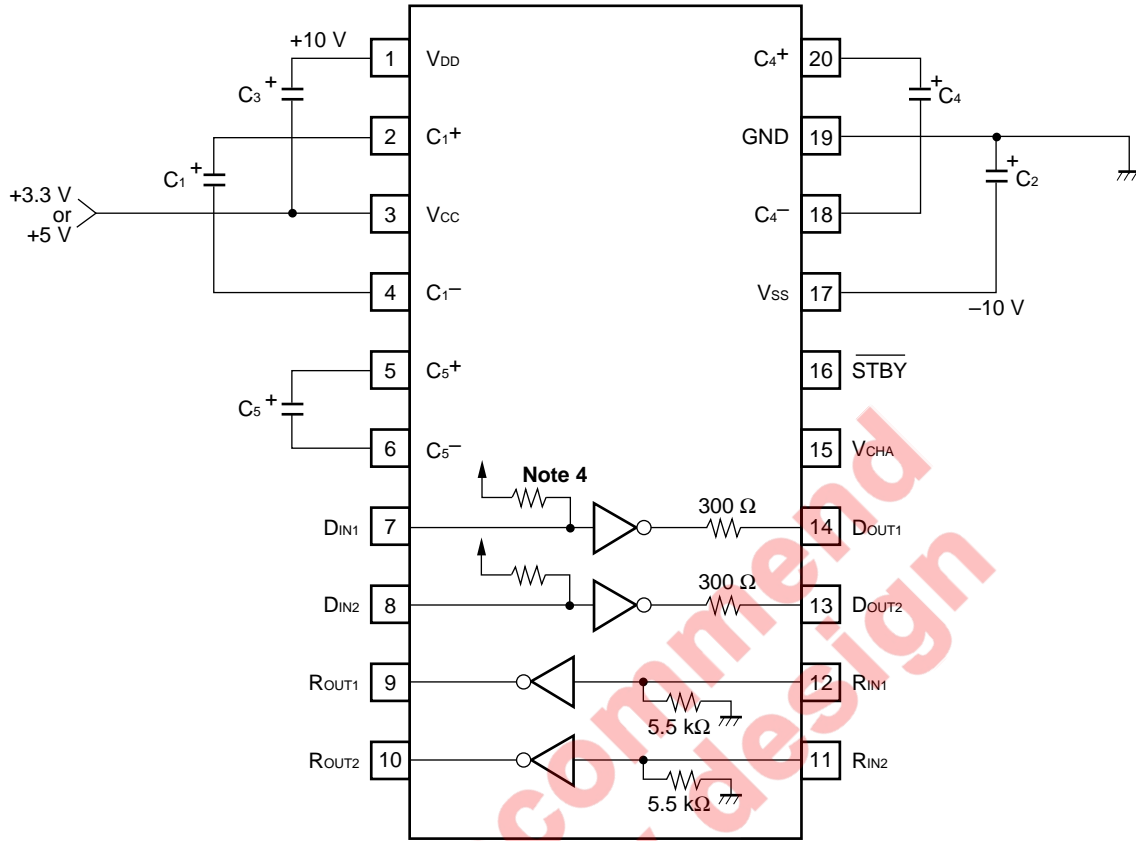

- Note 1.** V_{DD} and V_{SS} are output pins stepped up internally. These pins should not be loaded directly.
- 2.** Capacitors C₁ to C₅ with a breakdown voltage of 20 V or higher are recommended. And it is recommended to insert the capacitor that is 0.1 μF to 1 μF between V_{CC} and GND.
- 3.** If V_{CHA} is kept low level (in 5 V mode), capacitor C₅ is not necessary.
- 4.** The pull-up resistors at driver input are active resistors.

Truth Table

Driver

$\overline{\text{STBY}}$	D _{IN}	D _{OUT}	Remarks
L	×	Z	Standby mode (DC/DC converter is stopped)
H	L	H	Space level output
H	H	L	Mark level output

Receiver

$\overline{\text{STBY}}$	R _{IN}	R _{OUT}	Remarks
L	×	H	Standby mode (DC/DC converter is stopped)
H	L	H	Mark level input
H	H	L	Space level input

3 V ↔ 5 V switching Note 5

V _{CHA}	Operating mode
L	5 V mode (double step-up)
H	3 V mode (3 times step-up)

H: high-level, L: low-level, Z: high-impedance, x: H or L

Note 5. When switching V_{CHA}, standby mode must be selected ($\overline{\text{STBY}} = \text{L}$).

Not recommended for new design

ABSOLUTE MAXIMUM RATINGS (T_A = 25 °C)

Parameter	Symbol	Ratings	Unit
Supply Voltage (V _{CHA} = L)	V _{CC}	-0.5 to +7.0	V
Supply Voltage (V _{CHA} = H)	V _{CC}	-0.5 to +4.5	V
Driver Input Voltage	D _{IN}	-0.5 to V _{CC} +0.5	V
Receiver Input Voltage	R _{IN}	-30.0 to +30.0	V
Control Input Voltage ($\overline{\text{STBY}}$, V _{CHA})	V _{IN}	-0.5 to V _{CC} +0.5	V
Driver Output Voltage	D _{OUT}	-25.0 to +25.0 ^{Note 6}	V
Receiver Output Voltage	R _{OUT}	-0.5 to V _{CC} +0.5	V
Input Current (D _{IN} , $\overline{\text{STBY}}$, V _{CHA})	I _{IN}	±20.0	mA
Operating Ambient Temperature	T _A	-40 to +85	°C
Storage Temperature	T _{stg}	-55 to +150	°C
Total Power Dissipation	P _T	0.5	W

Note 6. Pulse width = 1 ms, duty = 10 % MAX.

RECOMMENDED OPERATING CONDITIONS

Parameter	Symbol	MIN.	TYP.	MAX.	Unit
Supply Voltage (V _{CHA} = L, 5 V mode)	V _{CC}	4.5	5.0	5.5	V
Supply Voltage (V _{CHA} = H, 3 V mode)	V _{CC}	3.0	3.3	3.6	V
High-Level Input Voltage (D _{IN})	V _{IH}	2.0		V _{CC}	V
Low-Level Input Voltage (D _{IN})	V _{IL}	0		0.8	V
High-Level Input Voltage ($\overline{\text{STBY}}$, V _{CHA})	V _{IH}	2.4		V _{CC}	V
Low-Level Input Voltage ($\overline{\text{STBY}}$, V _{CHA})	V _{IL}	0		0.6	V
Receiver Input Voltage	R _{IN}	-30		+30	V
Operating Ambient Temperature	T _A	-40		+85	°C
Capacitance of External Capacitor	^{Note 7}	0.33		4.7	μF

Note 7. In low temperature (below 0 °C), the capacitance of electrolytic capacitor becomes lower. Therefore, set higher values when using in low temperature.

Concerning the wiring length between the capacitor and the IC, the shorter the better.

Capacitors with good frequency characteristics such as tantalum capacitors, laminated ceramic capacitors, and aluminum electrolytic capacitors for switching power supply are recommended for the external capacitors.

ELECTRICAL SPECIFICATIONS (TOTAL)

(Unless otherwise specified, $T_A = -40$ to $+85$ °C, C_1 to $C_5 = 1$ μF)

Parameter	Symbol	Conditions	MIN.	TYP.	MAX.	Unit
Circuit Current	I _{CC1}	V _{CC} = +3.3 V, No load, R _{IN} pin OPEN, $\overline{STBY} = H$		6.5	13	mA
		V _{CC} = +5.0 V, No load, R _{IN} pin OPEN, $\overline{STBY} = H$		4.5	9	mA
Circuit Current	I _{CC2}	V _{CC} = +3.3 V, R _L = 3 kΩ (D _{OUT}), D _{IN} = GND, R _{IN} , R _{OUT} pin OPEN, $\overline{STBY} = H$		19	24	mA
		V _{CC} = +5.0 V, R _L = 3 kΩ (D _{OUT}), D _{IN} = GND, R _{IN} , R _{OUT} pin OPEN, $\overline{STBY} = H$		14	18	mA
Circuit Current at Standby	I _{CC3}	V _{CC} = +3.3 V, No load, D _{IN} and R _{IN} pins are OPEN, $\overline{STBY} = L$, T _A = 25 °C		1	3	μA
		V _{CC} = +3.3 V, No load, D _{IN} and R _{IN} pins are OPEN, $\overline{STBY} = L$		5		μA
		V _{CC} = +5.0 V, No load, D _{IN} and R _{IN} pins are OPEN, $\overline{STBY} = L$, T _A = 25 °C		2	5	μA
		V _{CC} = +5.0 V, No load, D _{IN} and R _{IN} pins are OPEN, $\overline{STBY} = L$		10		μA
High-Level Input Voltage	V _{IH}	V _{CC} = +3.0 to +5.5 V, \overline{STBY} , V _{CHA} pin	2.4			V
Low-Level Input Voltage	V _{IL}	V _{CC} = +3.0 to +5.5 V, \overline{STBY} , V _{CHA} pin			0.6	V
High-Level Input Current	I _{IH}	V _{CC} = +5.5 V, V _I = +5.5 V, \overline{STBY} , V _{CHA} pin			1	μA
Low-Level Input Current	I _{IL}	V _{CC} = +5.5 V, V _I = 0 V, \overline{STBY} , V _{CHA} pin			-1	μA
Input Capacitance	C _{IN}	Driver input and receiver input V _{CC} = +3.3 V, for GND, f = 1 MHz			10	pF
		Driver input and receiver input V _{CC} = +5.0 V, for GND, f = 1 MHz			10	pF
$\overline{STBY} - V_{CHA}$ Time	t _{SCH}	V _{CC} = +3.0 to +5.5 V, $\overline{STBY} \downarrow \rightarrow V_{CHA}$, Note 8	1			μs
V _{CHA} - \overline{STBY} Time	t _{CHS}	V _{CC} = +3.0 to +5.5 V, V _{CHA} $\rightarrow \overline{STBY} \uparrow$, Note 8	1			μs
$\overline{STBY} - V_{CC}$ Time	t _{SC}	V _{CC} = +3.0 to +5.5 V, $\overline{STBY} \downarrow \rightarrow V_{CC}$, Note 8	1			μs
V _{CC} - \overline{STBY} Time	t _{CS}	V _{CC} = +3.0 to +5.5 V, V _{CC} $\rightarrow \overline{STBY} \uparrow$, Note 8	1			μs

* The TYP. values are for reference at T_A = 25 °C.

Note 8. Measuring point

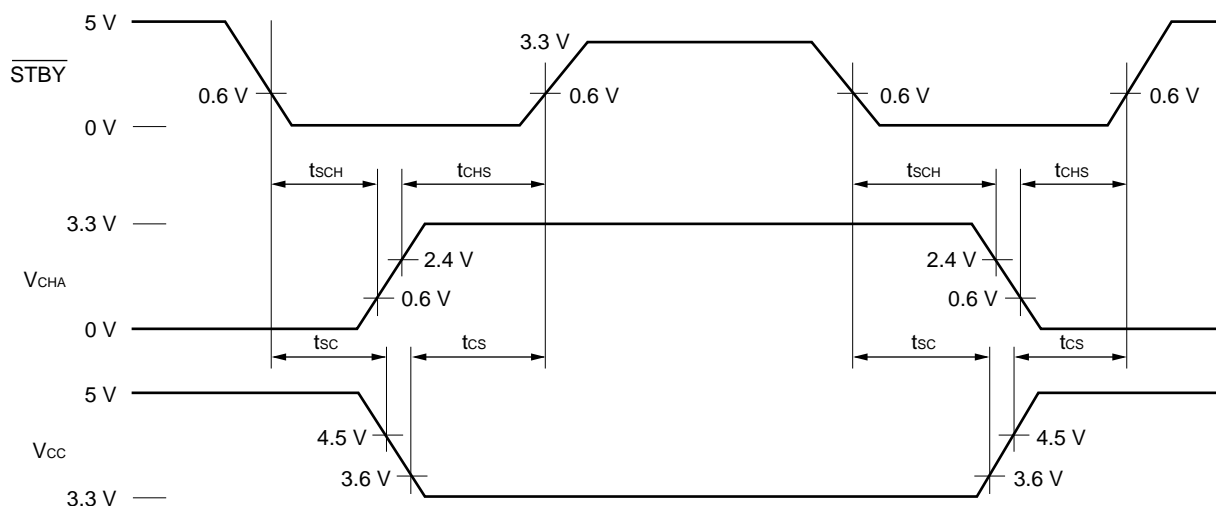

ELECTRICAL SPECIFICATIONS (DRIVER)

(Unless otherwise specified, $T_A = -40$ to $+85$ °C, C_1 to $C_5 = 1$ μF)

3 V mode (unless otherwise specified, $V_{CHA} = H$, $V_{CC} = 3.0$ to 3.6 V)

Parameter	Symbol	Conditions	MIN.	TYP.	MAX.	Unit
Low-Level Input Voltage	V_{IL}				0.8	V
High-Level Input Voltage	V_{IH}		2.0			V
Low-Level Input Current	I_{IL}	$V_{CC} = +3.6$ V, $V_I = 0$ V			-25	μA
High-Level Input Current	I_{IH}	$V_{CC} = +3.6$ V, $V_I = 3.6$ V			1.0	μA
Output Voltage	V_{DO}	$V_{CC} = +3.3$ V, $R_L = \infty$, $T_A = 25$ °C		±9.5		V
		$V_{CC} = +3.3$ V, $R_L = 3$ kΩ, $T_A = T_{opt}$	±5.0	±6.0		V
		$V_{CC} = +3.0$ V, $R_L = 3$ kΩ, $T_A = +25$ °C	±5.0			V
Output Short-Circuit Current	I_{SC}	$V_{CC} = +3.3$ V, for GND			±40	mA
Slew-Rate ^{Note 9}	SR	$C_L = 10$ pF, $R_L = 3$ to 7 kΩ	3.0		30	V/μs
		$C_L = 2\ 500$ pF, $R_L = 3$ to 7 kΩ	3.0		30	V/μs
Propagation Delay Time ^{Note 9}	t_{PHL}	$R_L = 3$ kΩ, $C_L = 2\ 500$ pF		2.5		μs
	t_{PLH}					
Output Resistor	R_O	$V_{CC} = V_{DD} = V_{SS} = 0$ V $V_{OUT} = \pm 2$ V	300			Ω
Standby Output Transfer Time	t_{DAZ}	$R_L = 3$ kΩ, $C_L = 2\ 500$ pF, ^{Note 10}		4	10	μs
Standby Output Transfer Time	t_{DZA}	$R_L = 3$ kΩ, $C_L = 2\ 500$ pF, ^{Note 10}		1	3	ms
Power-On Output Transfer Time	t_{PRA}	$R_L = 3$ kΩ, $C_L = 2\ 500$ pF, ^{Note 11}		1	3	ms

* The TYP. values are for reference at $T_A = 25$ °C.

5 V mode (Unless otherwise specified, $V_{CHA} = L$, $V_{CC} = +5.0\text{ V} \pm 10\%$)

Parameter	Symbol	Conditions	MIN.	TYP.	MAX.	Unit
Low-Level Input Voltage	V_{IL}				0.8	V
High-Level Input Voltage	V_{IH}		2.0			V
Low-Level Input Current	I_{IL}	$V_{CC} = +5.5\text{ V}$, $V_I = 0\text{ V}$			-40	μA
High-Level Input Current	I_{IH}	$V_{CC} = +5.5\text{ V}$, $V_I = 5.5\text{ V}$			1.0	μA
Output Voltage	V_{DO}	$V_{CC} = +5.0\text{ V}$, $R_L = \infty$, $T_A = 25\text{ }^\circ\text{C}$		±9.7		V
		$V_{CC} = +5.0\text{ V}$, $R_L = 3\text{ k}\Omega$, $T_A = T_{opt}$	±6.0			V
		$V_{CC} = +4.5\text{ V}$, $R_L = 3\text{ k}\Omega$, $T_A = T_{opt}$	±5.0			V
Output Short-Circuit Current	I_{SC}	$V_{CC} = +5.0\text{ V}$, for GND			±40	mA
Slew-Rate ^{Note 9}	SR	$C_L = 10\text{ pF}$, $R_L = 3\text{ to }7\text{ k}\Omega$	4.0		30	V/μs
		$C_L = 2\ 500\text{ pF}$, $R_L = 3\text{ to }7\text{ k}\Omega$	4.0		30	V/μs
Propagation Delay Time ^{Note 9}	t_{PHL} t_{PLH}	$R_L = 3\text{ k}\Omega$, $C_L = 2\ 500\text{ pF}$		2		μs
Output Resistor	R_O	$V_{CC} = V_{DD} = V_{SS} = 0\text{ V}$ $V_{OUT} = \pm 2\text{ V}$	300			Ω
Standby Output Transfer Time	t_{DAZ}	$R_L = 3\text{ k}\Omega$, $C_L = 2\ 500\text{ pF}$, ^{Note 10}		4	10	μs
Standby Output Transfer Time	t_{DZA}	$R_L = 3\text{ k}\Omega$, $C_L = 2\ 500\text{ pF}$, ^{Note 10}		0.5	1	ms
Power-On Output Transfer Time	t_{PRA}	$R_L = 3\text{ k}\Omega$, $C_L = 2\ 500\text{ pF}$, ^{Note 12}		0.5	1	ms

* The TYP. values are for reference at $T_A = 25\text{ }^\circ\text{C}$.

Note 9. Measuring point

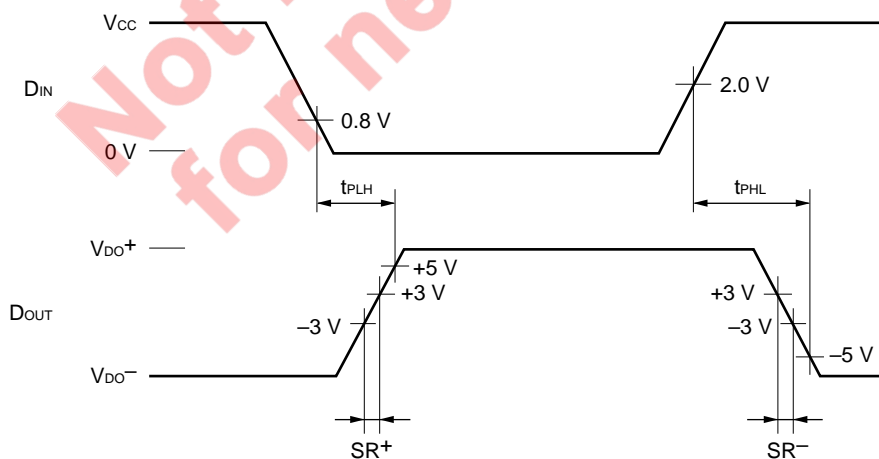

Note 10. Measuring point

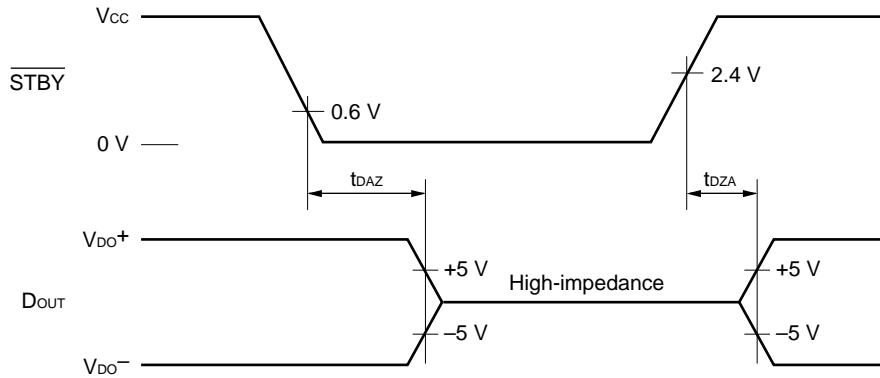

Driver outputs are indefinite during transition time (t_{DZA}).

Note 11. Measuring point

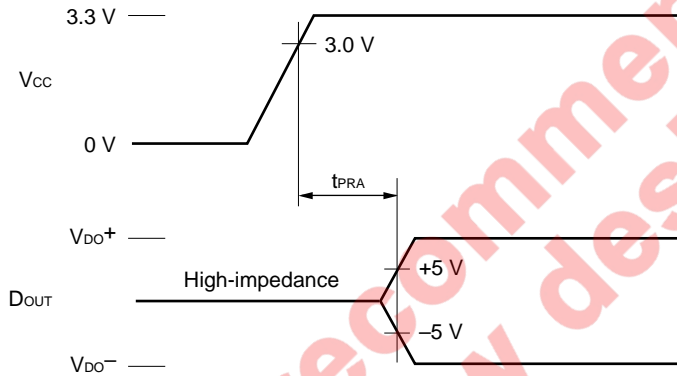

Driver outputs are indefinite during transition time (t_{PRA}).

Note 12. Measuring point

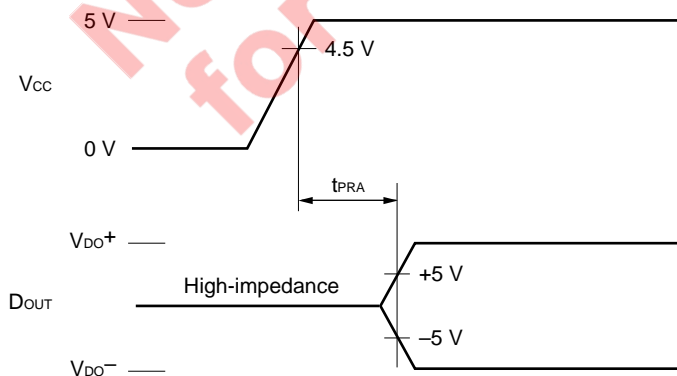

Driver outputs are indefinite during transition time (t_{PRA}).

ELECTRICAL SPECIFICATIONS (RECEIVER)

(Unless otherwise specified, $V_{CC} = 3.0$ to 5.5 V, $T_A = -40$ to $+85$ °C, C_1 to $C_5 = 1$ μF)

Parameter	Symbol	Conditions	MIN.	TYP.	MAX.	Unit
Low-Level Output Voltage	V_{OL1}	$I_{OUT} = 4$ mA, $\overline{STBY} = H$			0.4	V
High-Level Output Voltage	V_{OH1}	$I_{OUT} = -4$ mA, $\overline{STBY} = H$	$V_{CC} - 0.4$			V
Low-Level Output Voltage	V_{OL2}	$I_{OUT} = 4$ mA, $\overline{STBY} = L$			0.5	V
High-Level Output Voltage	V_{OH2}	$I_{OUT} = -4$ mA, $\overline{STBY} = L$	$V_{CC} - 0.5$			V
Propagation Delay Time ($\overline{STBY} = H$)	t_{PHL} t_{PLH}	$R_{IN} \rightarrow R_{OUT}$, $C_L = 150$ pF $V_{CC} = +3.0$ V, Note 13		0.2		μs
Input Resistor	R_I		3	5.5	7	kΩ
Input Pin Open Voltage	V_{IO}				0.5	V
Input Threshold ($\overline{STBY} = H$)	V_{IH}	$V_{CC} = +3.0$ to $+5.5$ V	1.7	2.3	2.7	V
	V_{IL}	$V_{CC} = +3.0$ to $+5.5$ V	0.7	1.1	1.7	V
	V_H	$V_{CC} = +3.0$ to $+5.5$ V (Hysteresis width)	0.5	1.2	1.8	V
Standby Output Transfer Time	t_{DAH}	Note 15		0.2	3	μs
Standby Output Transfer Time	t_{DHA}	$V_{CHA} = H$ (3 V mode) Note 15		0.6	3	ms
		$V_{CHA} = L$ (5 V mode) Note 15		0.3	1	ms
Power-On Reset Release Time	t_{PRA}	$V_{CHA} = H$ (3 V mode) Note 16		1	3	ms
		$V_{CHA} = L$ (5 V mode) Note 17		0.5	1	ms

* The TYP. values are for reference at $T_A = 25$ °C.

Not recommended for new design

Note 13. Measuring point

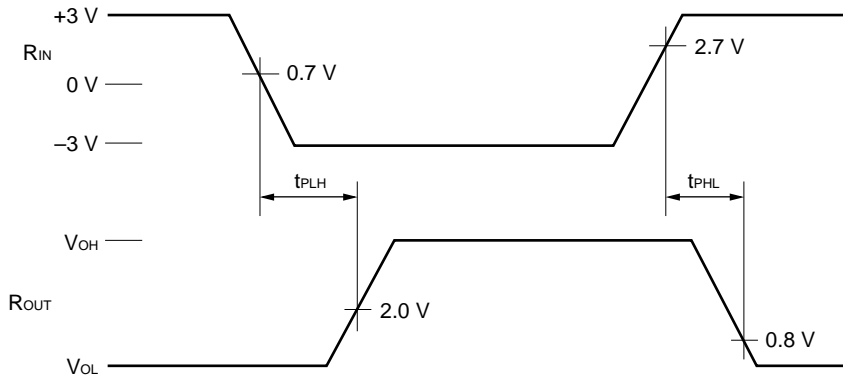

Note 14. Measuring point

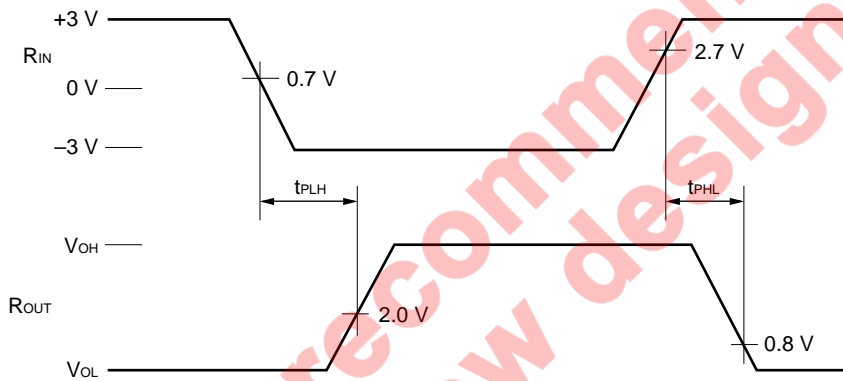

Note 15. Measuring point

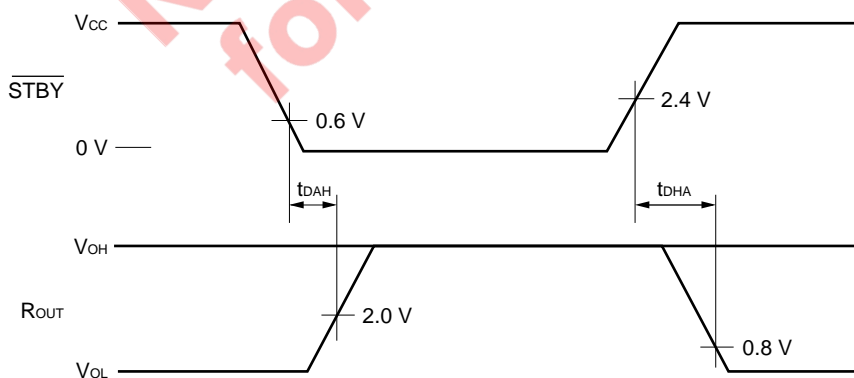

Receiver outputs are indefinite during transition time (t_{DHA}).

Note 16. Measuring point

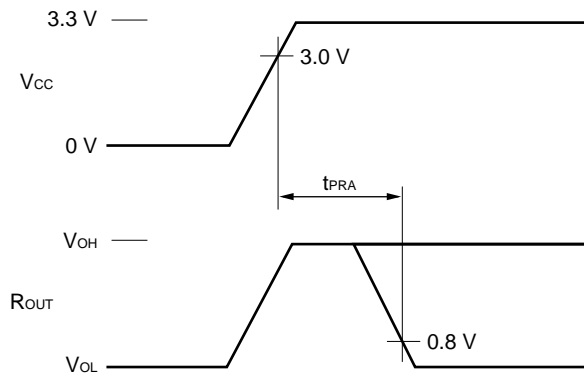

Receiver outputs are indefinite during reset release time (t_{PRA}).

Note 17. Measuring point

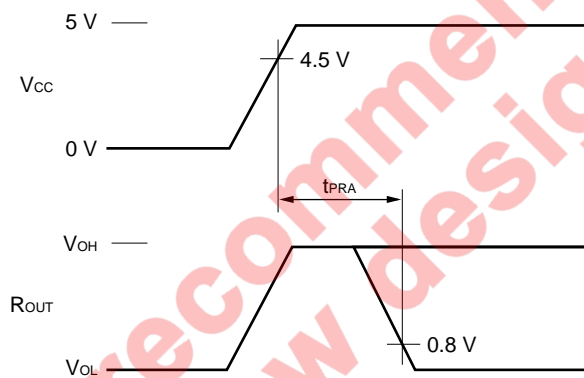

Receiver outputs are indefinite during reset release time (t_{PRA}).

REFERENCE MATERIAL

- IC PACKAGE MANUAL (C10943X)
- NEC SEMICONDUCTOR DEVICE RELIABILITY/QUALITY (IEI-1212)

RECOMMENDED SOLDERING CONDITIONS

The following conditions (See table below) must be met when soldering this product.

Please consult with our sales offices in case other soldering process is used, or in case soldering is done under different conditions.

TYPES OF SURFACE MOUNT DEVICE

For more details, refer to our document “SMT MANUAL” (C10535E).

μPD4721 GS-GJG

Soldering process	Soldering conditions	Symbol
Infrared ray reflow	Peak package’s surface temperature: 230 °C or below, Reflow time: 30 seconds or below (210 °C or higher), Number of reflow process: 2, Exposure limit*: None	IR30-00-2
VPS	Peak package’s surface temperature: 215 °C or below, Reflow time: 40 seconds or below (200 °C or higher), Number of reflow process: 2, Exposure limit*: None	VP15-00-2
Wave soldering	Solder Temperature: 260 °C or lower, Reflow time: Within 10 sec, Number of reflowprocess: 1, Exposure limit*: None	WS60-00-1
Partial heating method	Terminal temperature: 300 °C or below, Flow time: 10 seconds or below, Exposure limit*: None	○

* Exposure limit before soldering after dry-pack package is opened.
Storage conditions: 25 °C and relative humidity at 65 % or less.

Note Do not apply more than a single process at once, except for “Partial heating method”

PACKAGE DRAWINGS

20 PIN PLASTIC SHRINK SOP (300 mil)

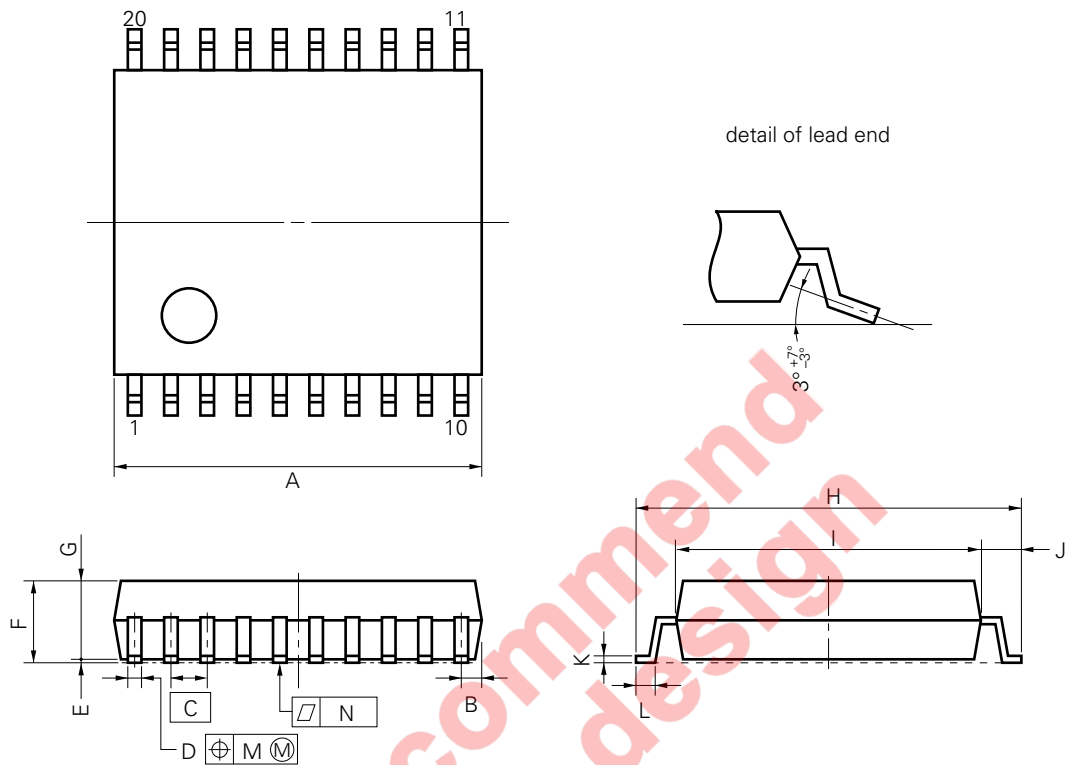

P20GM-65-300B-2

NOTE

Each lead centerline is located within 0.12 mm (0.005 inch) of its true position (T.P.) at maximum material condition.

ITEM	MILLIMETERS	INCHES
A	7.00 MAX.	0.276 MAX.
B	0.575 MAX.	0.023 MAX.
C	0.65 (T.P.)	0.026 (T.P.)
D	0.30±0.10	0.012 ^{+0.004} _{-0.005}
E	0.125±0.075	0.005±0.003
F	2.0 MAX.	0.079 MAX.
G	1.7	0.067
H	8.1±0.3	0.319±0.012
I	6.1±0.2	0.240±0.008
J	1.0±0.2	0.039 ^{+0.009} _{-0.008}
K	0.15 ^{+0.10} _{-0.05}	0.006 ^{+0.004} _{-0.002}
L	0.5±0.2	0.020 ^{+0.008} _{-0.009}
M	0.12	0.005
N	0.10	0.004

[MEMO]

Not recommend
for new design

[MEMO]

**Not recommend
for new design**

No part of this document may be copied or reproduced in any form or by any means without the prior written consent of NEC Corporation. NEC Corporation assumes no responsibility for any errors which may appear in this document.

NEC Corporation does not assume any liability for infringement of patents, copyrights or other intellectual property rights of third parties by or arising from use of a device described herein or any other liability arising from use of such device. No license, either express, implied or otherwise, is granted under any patents, copyrights or other intellectual property rights of NEC Corporation or others.

While NEC Corporation has been making continuous effort to enhance the reliability of its semiconductor devices, the possibility of defects cannot be eliminated entirely. To minimize risks of damage or injury to persons or property arising from a defect in an NEC semiconductor device, customers must incorporate sufficient safety measures in its design, such as redundancy, fire-containment, and anti-failure features.

NEC devices are classified into the following three quality grades:

"Standard", "Special", and "Specific". The Specific quality grade applies only to devices developed based on a customer designated "quality assurance program" for a specific application. The recommended applications of a device depend on its quality grade, as indicated below. Customers must check the quality grade of each device before using it in a particular application.

Standard: Computers, office equipment, communications equipment, test and measurement equipment, audio and visual equipment, home electronic appliances, machine tools, personal electronic equipment and industrial robots

Special: Transportation equipment (automobiles, trains, ships, etc.), traffic control systems, anti-disaster systems, anti-crime systems, safety equipment and medical equipment (not specifically designed for life support)

Specific: Aircrafts, aerospace equipment, submersible repeaters, nuclear reactor control systems, life support systems or medical equipment for life support, etc.

The quality grade of NEC devices is "Standard" unless otherwise specified in NEC's Data Sheets or Data Books. If customers intend to use NEC devices for applications other than those specified for Standard quality grade, they should contact an NEC sales representative in advance.

Anti-radioactive design is not implemented in this product.