

# MOTOR SOLUTIONS

Catalog



# RENESAS MOTOR SOLUTIONS FOR A GREENER SOCIETY

Renesas offers semiconductor products with low environmental impact throughout their life cycle in the interest of coexistence with the planet and harmony between humankind and the environment.



As the scope of motor applications has broadened in recent years, Renesas semiconductor devices for motors have come to be used in a wide variety of fields. Renesas provides customers with optimal motor solutions to help realize a greener society.

Visit the Renesas motor control website.

<https://www.renesas.com/solutions/proposal/motor-control.html>



POWERFUL SUPPORT FOR CUSTOMERS' DEVELOPMENT EFFORTS

## MOTOR SOLUTIONS

Offering a Wide Variety of Solutions

### Basic Motor Control Configuration

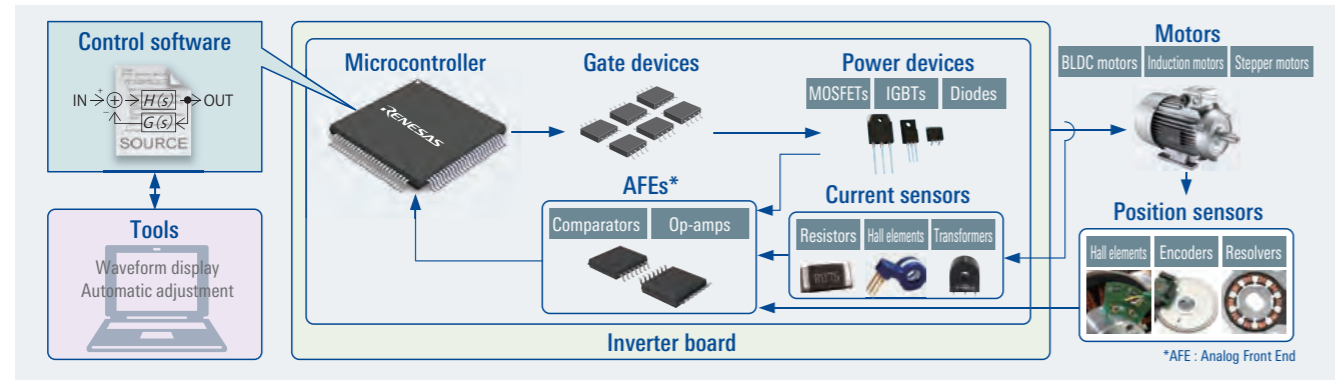

### Renesas Motor Solutions

• Renesas motor solutions comprise devices, hardware, software, and tools.

<b>Devices</b> <ul style="list-style-type: none"> <li>• Microcontrollers</li> <li>• MOSFETs</li> <li>• Op-amps</li> <li>• Diodes, etc.</li> </ul>	<b>Hardware</b> <ul style="list-style-type: none"> <li>• Inverter boards</li> <li>- High-voltage</li> <li>- Low-voltage</li> <li>• CPU cards</li> </ul>
<b>Software</b> <ul style="list-style-type: none"> <li>• Vector control</li> <li>- High-speed control, position control</li> <li>• 120-degree continuity control</li> </ul>	<b>Tools</b> <ul style="list-style-type: none"> <li>• Integrated development environments</li> <li>• Motor control development support tools</li> </ul>

### Support for Many Fields

• Renesas provides solutions for a variety of fields.

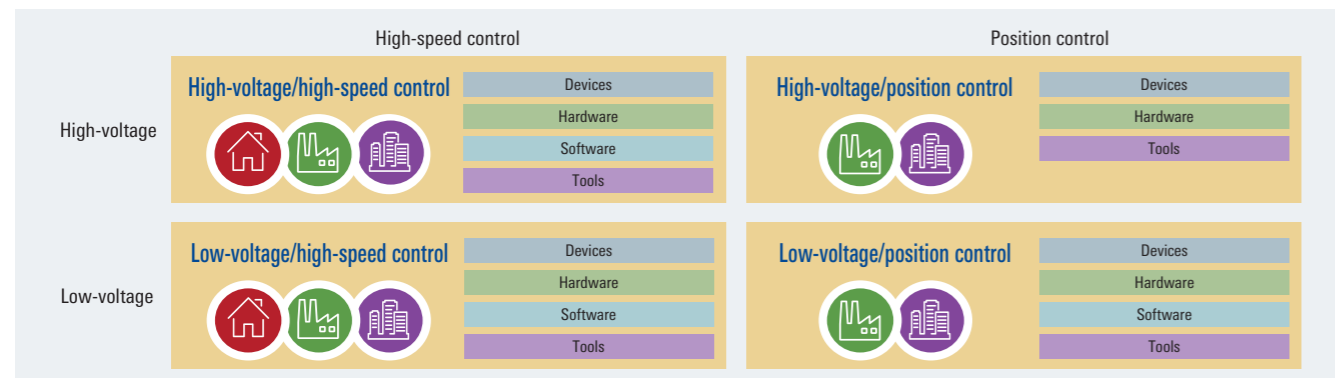

### Contributing to Development

• Renesas motor solutions help customers solve a variety of problems.

#### Development Sequence

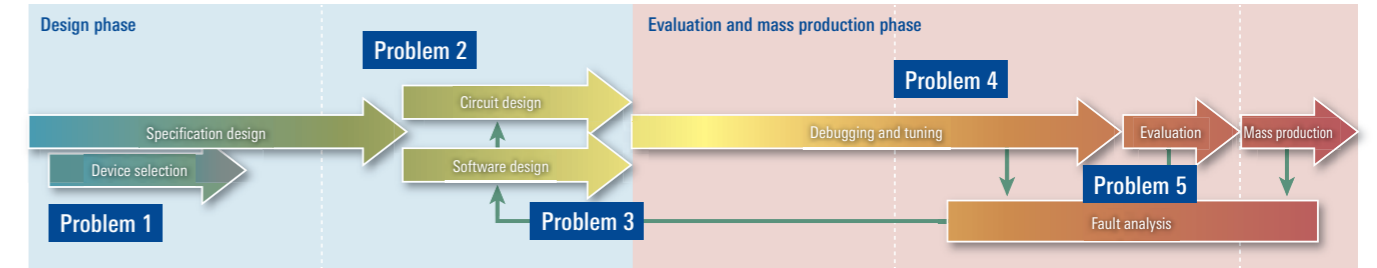

<b>Problem 1</b> Which devices should we use? You can find device recommendations for many applications on our website.	<b>Problem 2</b> We need reference data for circuit boards. Parts lists, circuit diagrams, and pattern diagrams of solution boards are available. These can be used as reference designs.	<b>Problem 3</b> Microcontroller settings are complicated. A variety of motor control software programs are available for use as reference. They are freely available for download on the web.
<b>Problem 4</b> We can't implement motor drive. Renesas tools include automatic adjustment functions to support motor drive applications. They make it simple to implement sensor-less vector control. No previous expertise required!	<b>Problem 5</b> Debugging is a chore. Renesas tools provide waveform display functions for safe debugging. The ability to display waveforms in real time boosts debugging efficiency.	

Refer to "http://www.renesas.com/" for information on the latest and detailed sales offices.

EASY-TO-USE REFERENCE DESIGNS FOR BOARD DEVELOPMENT

## MOTOR CONTROL HARDWARE AND KITS

Getting Started on Motor Control Right Away

### Solution Map

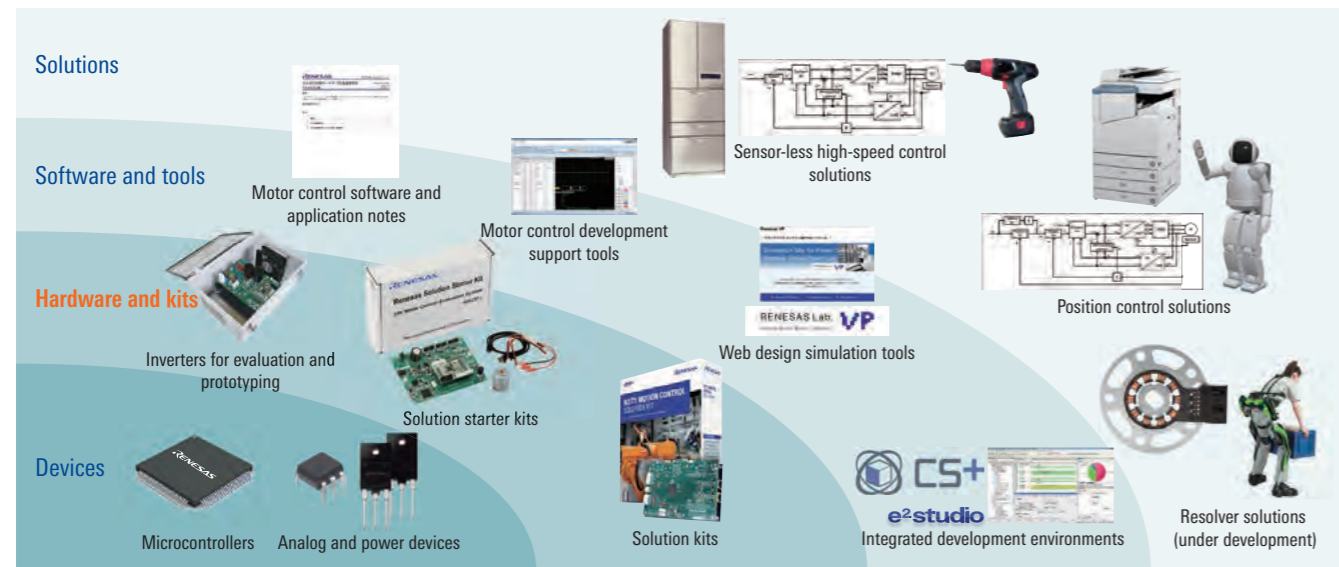

### Hardware and Kits

#### 24V Motor Control Evaluation System for RX23T

##### <Features>

- Get started with motor control immediately after purchase.
- Motor control software and application notes are available for a variety of control methods.
- Optional CPU cards provide support for many different microcontrollers.

##### <Options>

- RX23T CPU card
  - RX24T CPU card
  - RX24U CPU card
  - RL78/G1F CPU card
  - RL78/G14 CPU card
  - RL78/G1G CPU card
- Some options are products of Renesas partners.

##### <Permanent-Magnet Synchronous Motor>

- Rated voltage: 24V
- Rated current: 0.42A

##### <Inverter Control Block Specifications>

- Operating input voltage: 24V
- Rated output capacity: 60VA
- Switching frequency: 2 to 20kHz
- Dead time: 2.0 μsec. (recommended value)

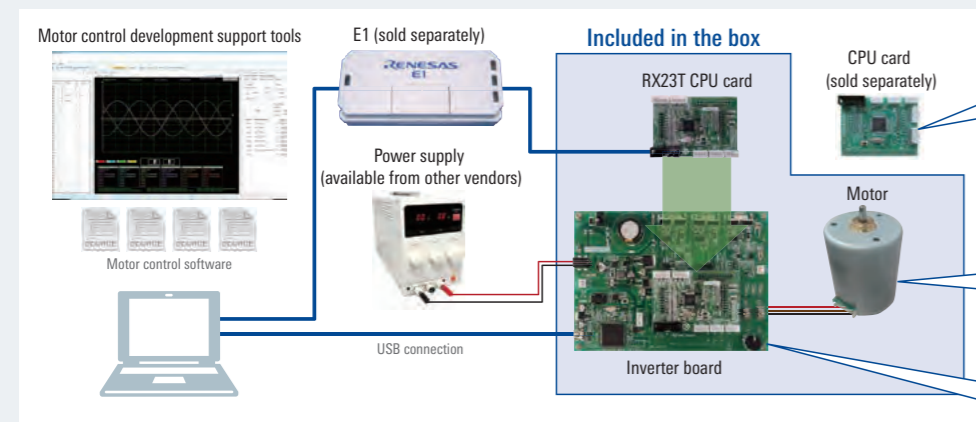

Ideal if you're getting started with motor control for the first time, if you're selecting a microcontroller for your application, or if you're examining motor control methods.

#### RX62T Low-Voltage Motor Control Evaluation System RL78/G14 Low-Voltage Motor Control Evaluation System

##### <Features>

- Enables use of the RX62T or RL78/G14 for permanent-magnet synchronous motor control.
- Package includes motor with Hall sensor and encoder, and E1 emulator.
- Motor control software and application notes are available for a variety of control methods.



#### RZ/T1 Motion Control Solution Kit

##### <Features>

- Package includes all parts needed for motor control evaluation.
- Supports safe design and can be used for reference.
- Includes multifunction utility tool.
- Servo control software is planned.

##### <Kit Contents>

- RZ/T1 CPU board and low-voltage 2-axis drive inverter board
- Motion utility tool
- AC servo motor
- Simple probe for debugging (I-jet Lite from IAR Systems)

Illustration of kit



##### <Motion Utility Tool>

Includes motor parameter setting and tuning functions. Supports multiple motor control methods, including trapezoidal control and S-curve acceleration and deceleration control.

Tool screenshots

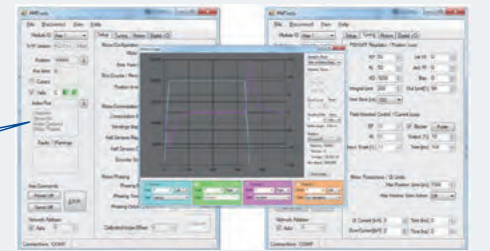

#### Compact Motor Module (Brushed DC Motor Module, Stepper Motor Control Board, Brushless DC Motor Control Board)

##### <Features>

- Allows you to implement various types of motor control without specialized knowledge. Simplifies development of low-cost and compact prototypes and demo units.
- Communication interfaces are available for Arduino and Raspberry Pi. Easily control motors using command APIs.
- Information on hardware and software is publicly available as a reference for development.



##### <Configuration>

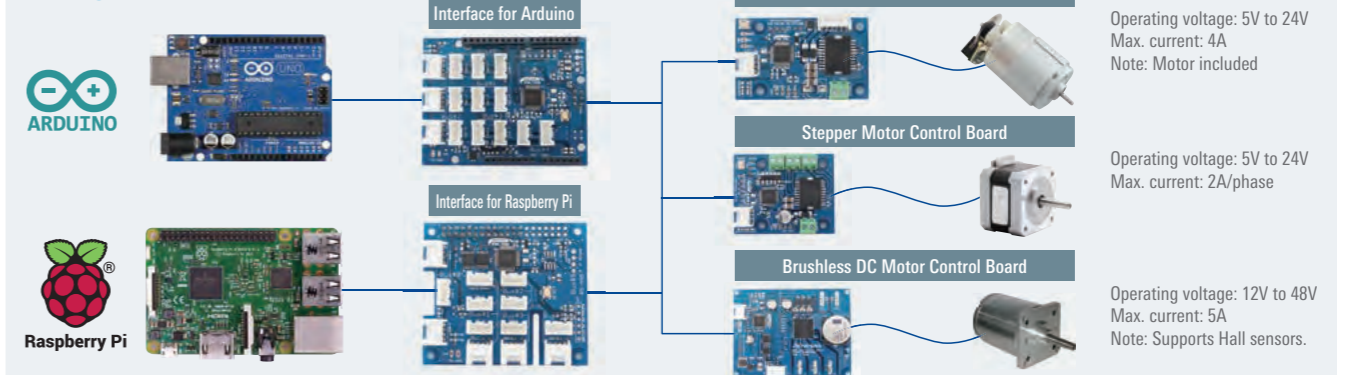

All trademarks or registered trademarks are the property of their respective owners.

Refer to "http://www.renesas.com/" for information on the latest and detailed sales offices.

SOFTWARE AND SUPPORT TOOLS FOR A VARIETY OF CONTROL METHODS

## MOTOR CONTROL SOFTWARE AND TOOLS

A Variety of Applications Ranging from Study through Development

### Solution Map

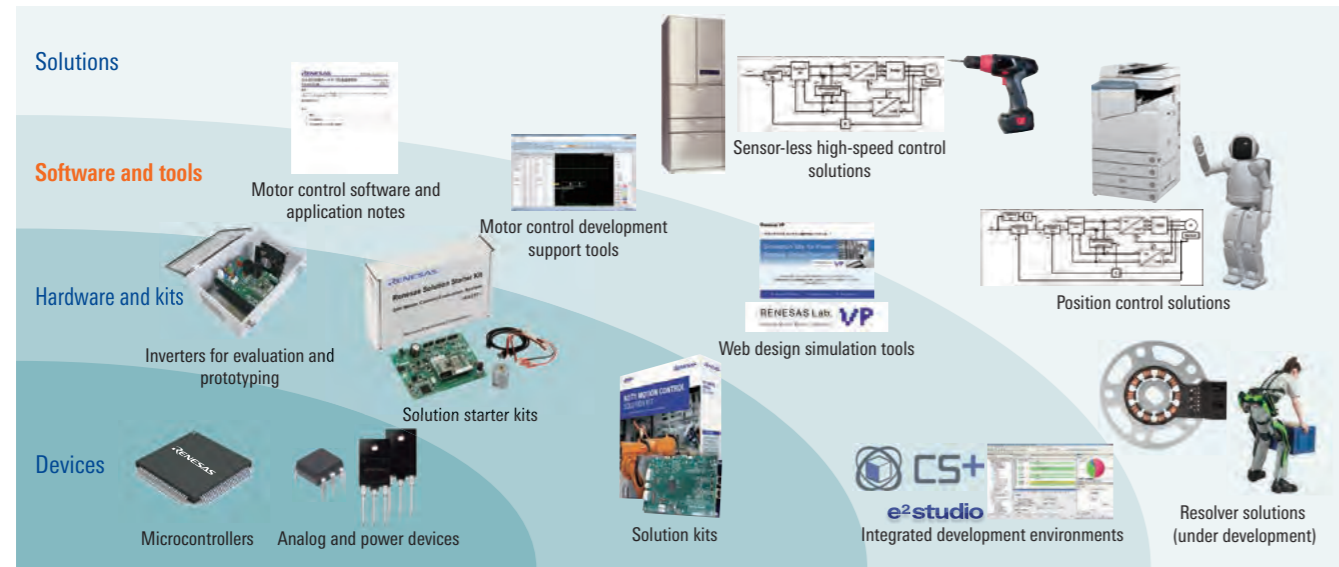

### Software

#### Motor Control Software and Application Notes

##### <Features>

- Sample programs are available for a variety of control methods, including vector control and 120-degree continuity control. These can serve as a valuable reference when writing your own programs.
- Available for immediate download from the Renesas website.

##### Motor Control Software

###### Practical software for more precise motor control

- Extended high-rpm range through use of weak magnetic flux
- Phase error correction for improved torque accuracy
- Vibration suppression at startup for enhanced safety

##### Application Notes

Algorithms: Explanation of algorithms for various control methods

Implementations: Explanation of motor control motor control program implementation on specific microcontrollers

Application notes covering initial microcontroller settings and the use of peripheral functions are also available.

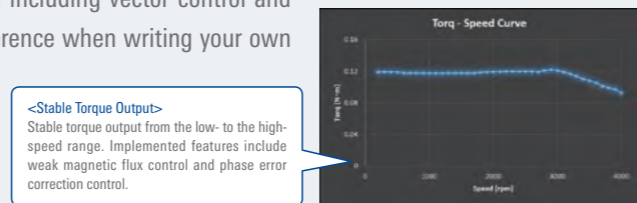

Example torque and speed characteristics

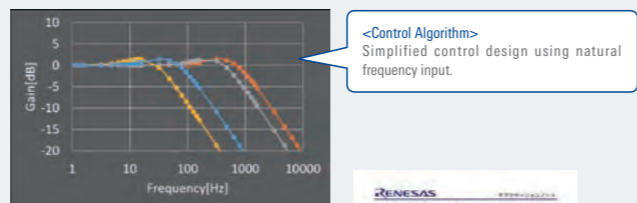

Example frequency characteristics



### Tools

#### Motor Control Development Support Tool (Renesas Motor Workbench)

##### <Features>

- Waveform display function and automatic adjustment function
- The only resources of the target microcontroller needed are the UART and DTC.
- Fully isolated for safety.
- An essential tool for motor control debugging.

##### Configuration of Motor Control Development Support Tool



Note: A communication board is required to use the tool. Renesas solution starter kits include board circuits for communication.

##### Analyzer

##### <Features>

- Dynamic writing of microcontroller internal variables
- Real-time waveform display of variables
- Trigger and zoom functions for simplified analysis

Analysis and manipulation are possible without stopping the CPU. Instruction values can be manipulated. Evaluation is simplified.

##### Analyzer Screenshots

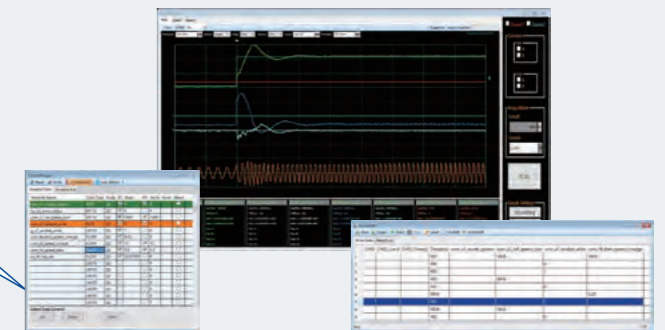

##### Tuner

##### <Features>

- Automatically adjust parameters needed for vector control with no specialized knowledge (measurement of motor parameters, identification of control parameters).
- Adjustment results can be output to a file (PDF file or program header file).
- The manual adjustment function lets you easily make fine adjustments.

##### <Tuner Usage Example>

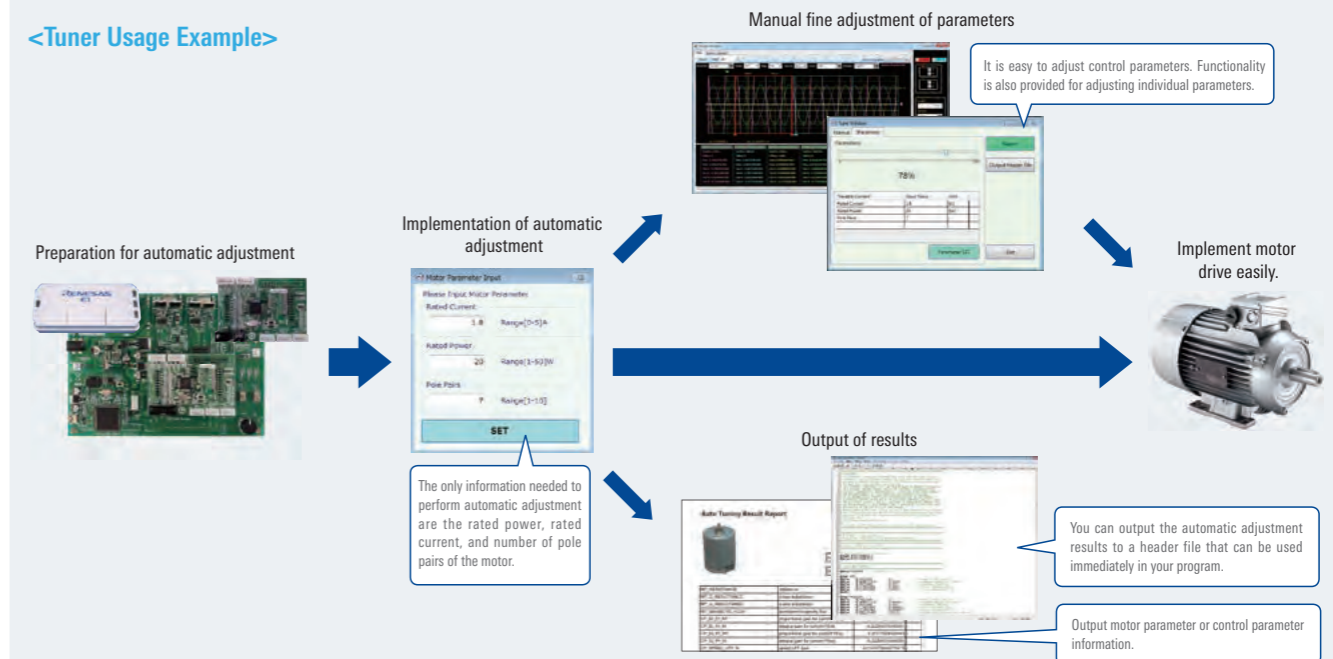

Note: Automatic adjustment requires the 24V Motor Control Evaluation System for RX23T.

## GENERAL-PURPOSE MICROCONTROLLERS FOR INVERTER CONTROL

# RL78/G14, RL78/G1F, RL78/G1G

Excellent Cost-to-Performance Ratio, Low Power Consumption

### Product Features

#### RL78 Family

- 16-bit microcontrollers combining low power consumption and high performance
- Microcontrollers that retain the advantages of the 78K Family and R8C Family while delivering an excellent cost-to-performance ratio

#### G14 A multifunction microcontroller standard that is ideal for motor control

On-chip motor control timer with support for three-phase complementary PWM output and two-phase encoder timer. CPU core with support for multiply-and-divide and multiply-and-accumulate instructions for enhanced arithmetic performance. Extensive lineup with 10 memory configurations and 17 package options.

#### G1F A microcontroller that delivers plenty of flexibility in terms of multifunctionality, sophisticated control capabilities, and fewer external components

Extends and enhances the motor control functions of the RL78/G14. Enables sophisticated sensor-less motor control and requires fewer external components to help reduce system cost! Lineup includes compact 4mm-square package that requires less space!

#### G1G A microcontroller that helps keep the system cost down

Numerous on-chip functions for motor control combined with additional functions and performance at an affordable cost! Lineup includes packages with 0.65mm or 0.8mm lead pitch for ease of assembly.

#### RL78 Family Products with Support for BLDC Motor Control

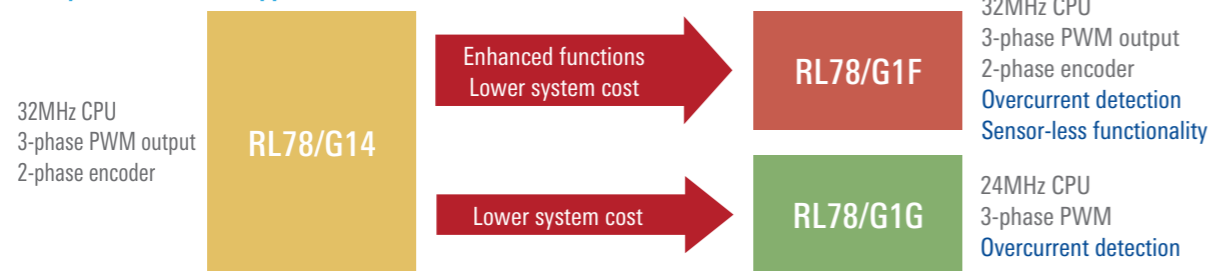

### Functions for Motor Control

#### Example of Sensor-Less BLDC Motor Control Using RL78

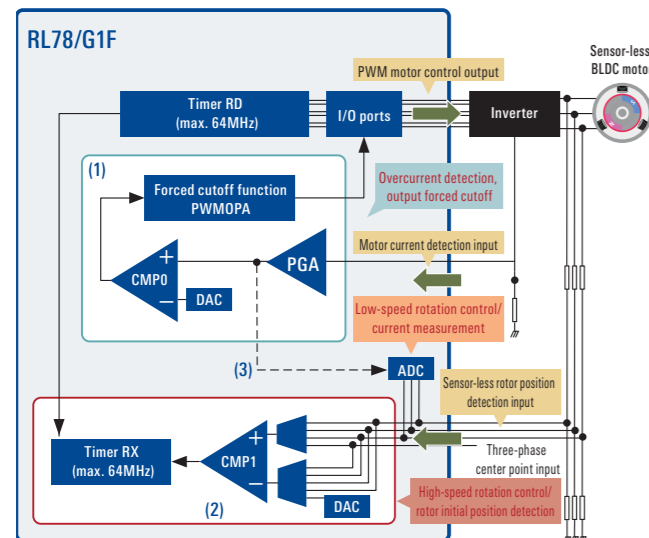

#### (1) Overcurrent detection and output forced cutoff functions **G1F G1G**

High-speed PGA and high-speed comparator (CMP0) for overcurrent detection, plus linked PWM control output forced cutoff function (PWMOPA) are integrated on-chip.

> Fast overcurrent detection with fewer external parts needed, allowing immediate forced cutoff of PWM output, bypassing the CPU.

#### (2) Sensor-less control functions **G1F**

Four-input-selectable high-speed comparator (CMP1) and timer RX for sensor-less rotor position detection are integrated on-chip.

> Enables zero-crossing detection at high rotation speeds and motor position detection when the motor is stopped. Expands the possible applications for sensor-less BLDC motors and facilitates operational improvements.

#### (3) Current measurement using on-chip high-speed PGA **G1F**

On-chip PGA delivers high slew rate of min. 3.5V/ $\mu$  sec. for effective current measurement in single-shunt vector control applications.

> Enables vector control with fewer external parts.

### Lineup

ROM	Pin Count	Package													
		24	30	32	36	40	44	48	52	64	80	100			
512KB								48/8	48/8		48/8	48/8		48/8	48/8
384KB								32/8	32/8		32/8	32/8		32/8	32/8
256KB							24/8	24/8	24/8		24/8	24/8	24/8	24/8	24/8
192KB						20/8	20/8	20/8	20/8		20/8	20/8	20/8	20/8	20/8
128KB		16/8	16/8	16/8	16/8	16/8	16/8	16/8	16/8	16/8	16/8	16/8	16/8	16/8	16/8
96KB		12/8	12/8	12/8	12/8	12/8	12/8	12/8	12/8	12/8	12/8	12/8	12/8	12/8	12/8
64KB		5.5/4	5.5/4	5.5/4	5.5/4	5.5/4	5.5/4	5.5/4	5.5/4	5.5/4	5.5/4	5.5/4	5.5/4	5.5/4	5.5/4
48KB		5.5/4	5.5/4	5.5/4	5.5/4	5.5/4	5.5/4	5.5/4	5.5/4	5.5/4	5.5/4	5.5/4	5.5/4	5.5/4	5.5/4
32KB		5.5/4	4/4	4/4	4/4	4/4	4/4	4/4	4/4	4/4	4/4	4/4	4/4	4/4	4/4
16KB		2.5/4	2.5/4	2.5/4	2.5/4	2.5/4	2.5/4	2.5/4	2.5/4	2.5/4	2.5/4	2.5/4	2.5/4	2.5/4	2.5/4
8KB		1.5/-	1.5/-	1.5/-	1.5/-	1.5/-	1.5/-	1.5/-	1.5/-	1.5/-	1.5/-	1.5/-	1.5/-	1.5/-	1.5/-
Package	Pin pitch unit: mm	HWFN 4x4mm 0.5 pitch	SSOP 7.62mm 0.65 pitch	HWFN 5x5mm 0.5 pitch	LQFP 7x7mm 0.8 pitch	WFLGA 4x4mm 0.5 pitch	HWFN 6x6mm 0.5 pitch	LQFP 10x10mm 0.8 pitch	HWFN 7x7mm 0.5 pitch	LQFP 10x10mm 0.65 pitch	WFLGA 5x5mm 0.5 pitch	LQFP 10x10mm 0.5 pitch	LQFP 14x14mm 0.8 pitch	LQFP 12x12mm 0.5 pitch	LQFP 14x14mm 0.65 pitch

Specifications are available for consumer applications (A): TA = -40 to +85°C, and industrial applications (G): TA = -40 to +105°C. (The RL78/G1G is not available in a specification for industrial applications.)

### Specifications

Product Group	RL78/G14				RL78/G1F		RL78/G1G		
	30 to 64 pins		80 to 100 pins		24 to 64 pins		30 to 44 pins		
Pin count	30 to 64 pins		80 to 100 pins		24 to 64 pins		30 to 44 pins		
Main CPU	RL78 CPU-S3 core								
Memory	Flash ROM [bytes]	16K to 64K		96K to 512K		32K/64K		8K/16K	
	Data flash [bytes]	4K		8K		4K		-	
	RAM [bytes]	2.5K to 5.5K		12K to 48K		5.5K		1.5K	
Operating clocks <sup>1</sup>	Max. operating frequency	On-chip oscillator clock	32MHz						24MHz
		External resonator	20MHz						-
		Timer RD/RX clock	64MHz						48MHz
Oscillation circuit	Crystal/ceramic <sup>2</sup>	1 to 20MHz						-	
	High-speed on-chip oscillator <sup>3</sup>	1 to 64MHz						1M to 48MHz	
	Low-speed on-chip oscillator	15kHz						-	
I/O	I/O ports	Subclock	32.768kHz (40 pins and over)						32.768kHz (36 pins and over)
		Nch open drain (6V voltage tolerance)	26 to 58		74 to 92		20 to 58		26 to 40
		Nch open drain (VDD/EVDD voltage tolerance)	2 to 4		4		0 to 4		-
Timers	16-bit timer TAU [channels]	4, PWM output × 3		8, PWM output × 6		4, PWM output × 3		-	
	16-bit timer RJ [channels]	1						-	
	16-bit timer RD [channels]	2, PWM output × 6						-	
	16-bit timer RG [channels]	1, PWM output × 1						-	
	16-bit timer RX [channels]	-						1	
	Real-time clock [channels]	1 <sup>2</sup>						-	
	Watchdog timer (WDT) [channels]	1						-	
	Interval timer [channels]	12-bit × 1						-	
Serial interface	Serial array unit (max. channel count)	CSI × 3/UART × 3/simple I <sup>2</sup> C × 3 to CSI × 6/UART × 3/		CSI × 8/UART × 4/simple I <sup>2</sup> C × 8		CSI × 3/UART × 3/simple I <sup>2</sup> C × 3 to CSI × 6/UART × 3/simple I <sup>2</sup> C × 6		CSI × 1/UART × 2/simple I <sup>2</sup> C × 1	
	LIN-bus/IrDA support	1/1		1/-		1/1		-/-	
Data transfer controller (DTC)	On-chip								
Event link controller (ELC)	On-chip								
External interrupt pins	6 to 15 (19) <sup>3</sup>		15 (19) to 16 (20) <sup>3</sup>		9 to 20		6 to 7		
On-chip debugging (OCD)	Supported		Supported		Supported (supported by trace function)		Supported		
Peripheral functions	8-/10-bit A/D converter [channels]	8 to 12		17 to 20		8 to 17		8 to 12	
	8-bit D/A converter [channels]	-		2 (1 on 30-pin products)		2		-	
	Multiply-and-divide, multiply-and-accumulate	Multiply-and-divide and multiply-and-accumulate instruction support (included in CPU instruction set), multiply: 16-bit × 16-bit = 32-bit (signed/unsigned), divide: 32-bit ÷ 32-bit = 32-bit (unsigned), multiply-and-accumulate: 16-bit × 16-bit ÷ 32-bit = 32-bit (signed/unsigned)							
	Comparator [channels]	-		2		2 (high-speed, with reference voltage D/A converter)		2 (high-speed, with reference voltage D/A converter)	
	Programmable-gain amplifier (PGA) [channels]	-		-		1 (high slew rate)		1	
	PWM option unit	-		-		PWMOPA		PWMOP	
Other functions	Power-on reset (POR), voltage detection circuit (LVD), clock/buzzer outputs: 0 to 2 channels								
Safety functions	Flash memory CRC calculation function (high-speed), CRC calculation function (general-purpose), RAM parity error detection function, RAM card function, SFR card function, illegal memory access detection function, frequency detection function, A/D converter test function, I/O port output signal level detection function								
Other	Power supply voltage	V <sub>DD</sub> = 1.6 to 5.5V (Additional power supply voltage (EVDD) supported on products with 64 pins and over (also supported on 36-pin versions of RL78/G1F))						V <sub>DD</sub> = 2.7 to 5.5V	
	Operating ambient temperature range [°C]	T <sub>A</sub> = -40 to +85°C (A: consumer applications), T <sub>A</sub> = -40 to +105°C (G: industrial applications)						T <sub>A</sub> = -40 to +85°C (A: consumer applications)	

\* A dedicated library is required to use the data flash.  
<sup>1</sup> The maximum frequency at which operation is possible differs depending on the voltage range. Listed values assume VDD = 2.7 to 5.5V.  
<sup>2</sup> On products without subclock oscillation support, only the fixed-cycle interrupt function using the low-speed on-chip oscillator clock (15KHz) can be used.  
<sup>3</sup> Items in parentheses ( ) are maximum values when using the PIOR function.  
 With some exceptions, products listed in this catalog incorporate SuperFlash™ technology licensed from Silicon Storage Technology, Inc. SuperFlash™ is a registered trademark, in Japan and other countries, of Silicon Storage Technology, Inc. of the United States.

Refer to "http://www.renesas.com/" for information on the latest and detailed sales offices.

NEW 32-BIT MICROCONTROLLERS FOR INVERTER CONTROL: ENTRY MODELS RETAINING THE ADVANCED FUNCTIONS OF THE RX62T

# RX23T, RX24T

Easy and Smooth Migration from Earlier RX Products

## Product Features

### RX Family

These 32-bit microcontrollers built around Renesas' exclusive RXv1 and RXv2 cores offer powerful arithmetic performance alongside excellent power efficiency.

**RX23T: 40MHz, 5V, FPU, 12-bit ADC × 1, 3-channel simultaneous sample-and-hold, on-chip high-precision resonator**

**RX24T: 80MHz, 5V, FPU, 12-bit ADC × 3, programmable-gain amplifier, 3-channel simultaneous sample-and-hold**

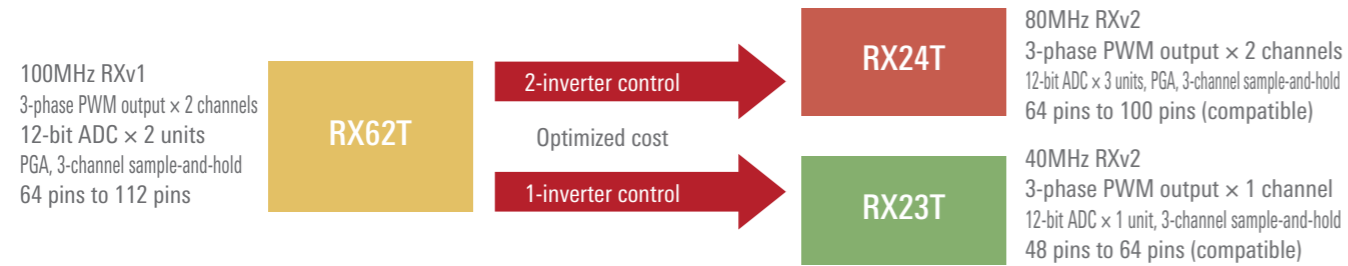

## Motor Control Functions and Product Details

### High-performance 12-bit A/D converter with PGA

High-performance ADCs enabling simultaneous control of two motors!  
 • Sample-and-hold circuit that supports simultaneous operation on three channels  
 • PGA for current detection using shunt resistors

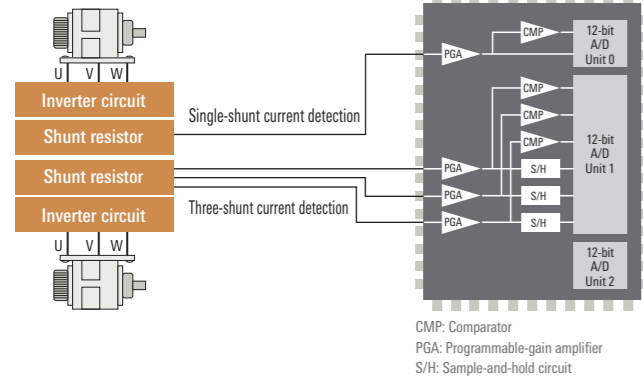

### Migration from Existing Products

**Pin-compatible and function-compatible with the RX62T!**

High degree of compatibility in pin assignments and function set simplifies migration!

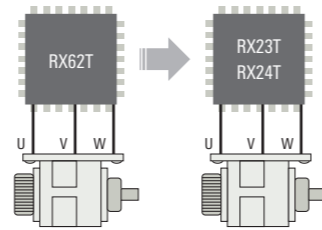

### Comparison of Execution Cycle Performance and Code Size Using FPU

Note: Comparison by Renesas (comparison of results with and without FPU using Renesas motor control software)

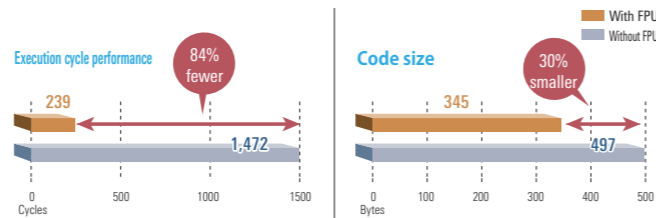

### Effects of FPU Eliminating the Need for Scaling

```

Without FPU
int mtr_L = 0.0009447 * 1099511627778;
int Iq;
int Omega;
int Vd;
int temp0;
/*Vd=Vd - (Omega * mtr_L * Iq)*/
temp0 = (mtr_L * Iq) >> 31;
temp0 = (Omega * temp0) >> 29;
Vd = Vd - temp0;

Processing is complex and difficult to understand.

With FPU
/*mtr_L = 0.0009447*/
float Iq;
float Omega;
float Vd;
/*Vd=Vd - (Omega * mtr_L * Iq)*/
/*Vd=Vd - (Omega * 0.0009447 * Iq);

Simple and easy to understand.
    
```

### Valuable Functions to Support Safe and Secure Products

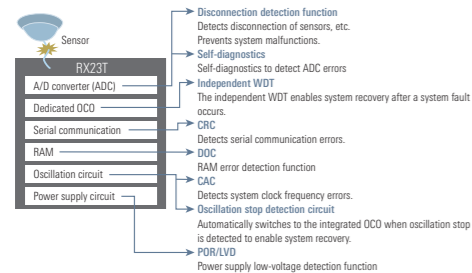

## Lineup

■:RX23T ■:RX24T

Pin Count	48	52	64	80		100
Flash/ RAM/ E2 Data Flash						
256KB/16KB/8KB			AADF	AADF	AADF	AADF
128KB/16KB/8KB			8ADF	8ADF	8ADF	8ADF
128KB/12KB/-	5AyFL	5AyFD	5AyFM			
64KB/12KB/-	3AyFL	3AyFD	3AyFM			
Package	LFQFP	LQFP	LFQFP	LFQFP	LQFP	LFQFP
Pitch (mm)	0.5	0.65	0.5	0.5	0.65	0.5
Dimensions (mm × mm)						
	7 × 7	10 × 10	10 × 10	12 × 12	14 × 14	14 × 14

Part numbers: R5F523TxxDxx (-40 to 85°C), R5F523TxxGxx (-40 to 105°C), R5F524TxxDxx (-40 to 85°C)  
 See the table above for the portion corresponding to xxxxx. y represents D or G.

## Specifications

Product Group	RX62T 64-Pin	RX23T 64-Pin	RX62T 100-Pin	RX24T 100-Pin
Main CPU	RXv1 w/ FPU	RXv2 w/ FPU	RXv1 w/ FPU	RXv2 w/ FPU
Max. operating frequency	100MHz	40MHz	100MHz	80MHz
Power supply voltage	3.3 or 5.0V	2.7-5.5V	3.3 or 5.0V	2.7-5.5V
On-chip high-speed oscillator	-	32MHz	-	32/64MHz
ROM	256KB	128KB	256KB	256KB
RAM	16KB	12KB	16KB	16KB
Data flash	32KB	-	32KB	8KB
MTU3	16-bit × 8 channels	16-bit × 6 channels	16-bit × 8 channels	16-bit × 9 channels
GPT	16-bit × 4 channels	-	16-bit × 4 channels	16-bit × 4 channels
12-bit ADC	2 units (8 channels)	1 unit (10 channels)	2 units (8 channels)	3 units (22 channels)
3-channel sample-and-hold	2 units	1 unit	2 units	1 unit
PGA	3 channels + 3 channels	-	3 channels + 3 channels	1 channel + 3 channels
Comparator	3 channels + 3 channels	3 channels	3 channels + 3 channels	4 channels
10-bit ADC	-	-	1 unit (12 channels)	-
SCI/RSPI/IIC	3 channels/1 channel/1 channel	2 channels/1 channel/1 channel	3 channels/1 channel/1 channel	3 channels/1 channel/1 channel
CAN/LIN/USB	1 channel/1 channel / -	- / - / -	1 channel/1 channel / -	- / - / -
Functional safety	✓	✓	✓	✓
Supported inverter control count and port count	1-inverter control I/O: 37, I: 9	1-inverter control I/O: 50, I: 1	2-inverter control I/O: 55, I: 21	2-inverter control I/O: 80, I: 1

Refer to "http://www.renesas.com/" for information on the latest and detailed sales offices.

## HIGH-END CONTROLLERS FOR AC SERVO MOTORS

# RZ/T1

### Single-Chip Solution for AC Servo Applications

#### Product Features

- Built around ARM® Cortex®-R4 processor with FPU with maximum operating frequency of 600MHz.
- Tightly-coupled memory enables high-speed, real-time operation.
- R-IN Engine accelerator for industrial Ethernet communication supports a variety of industrial Ethernet standards.
- Encoder interface supports protocols such as EnDat, BiSS® C, and A-format™.

#### Tightly-Coupled Memory for Excellent Real-Time Performance

The high-speed CPU core and tightly-coupled memory deliver high-speed, real-time operation.

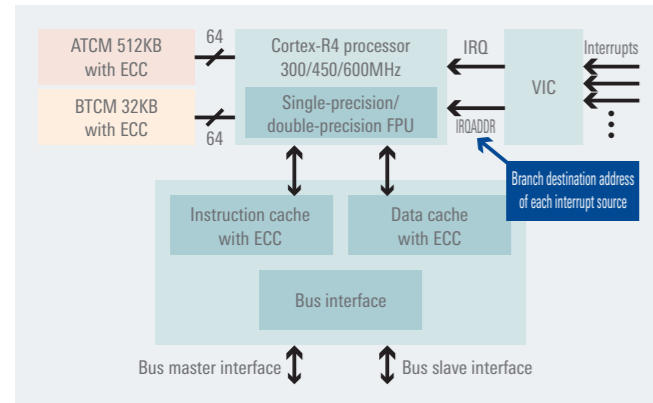

#### Industrial Ethernet Communication Accelerator

R-IN Engine for high-speed Internet communication

- Supports multiple industrial Ethernet protocols.
- Performs standard Internet processing in hardware.
- Performs high-speed network processing four times faster than earlier products.

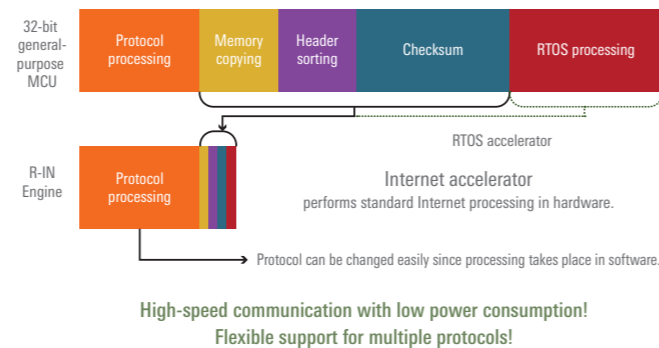

#### On-Chip Integration of Functions Required by AC Servo Systems

- Features such as absolute encoder interface, industrial Ethernet communication functions, and delta-sigma A/D interface, which previously required external devices when using a conventional FPGA, are integrated on-chip.
- Makes it possible to design AC servo systems with fewer components and reduced cost.

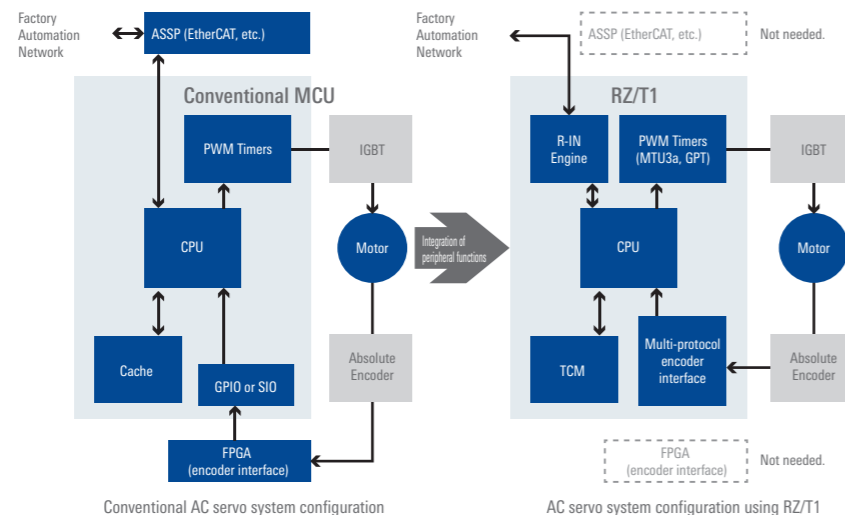

## Product Specifications

Item	Products without R-IN Engine							Products with R-IN Engine		
	Product No.	R7S910001	R7S910002 R7S910011	R7S910006	R7S910007 R7S910013	R7S910025 R7S910026	R7S910027 R7S910028	R7S910035 R7S910036	R7S910015 R7S910016	R7S910017 R7S910018
Package	176HLQFP 0.4mm pitch 20mm × 20mm	320FPBGA 0.8mm pitch 17mm × 17mm								
Main CPU	ARM® Cortex®-R4 Processor with FPU									
Max. operating frequency	450MHz			600MHz	450MHz	600MHz	300MHz	450MHz	600MHz	
FPU	Support for single-precision and double-precision add, subtract, multiply, divide, multiply-and-accumulate, and square root calculation									
Tightly-coupled memory	ATCM: 512KB (ECC) BTCM: 32KB (ECC)									
Cache memory	Instruction cache: 8KB (ECC) Data cache: 8KB (ECC)									
Communication accelerator	-							Industrial Ethernet Communication accelerator R-IN Engine		
EtherCAT® slave controller	-							Supported		
Extended on-chip SRAM	-			1MB (ECC)				-		1MB (ECC) <i>Note: Also used to store protocol stack.</i>
Clocks	External clock/resonator input frequency: 25MHz CPU clock frequency: Up to 300/450/600MHz Low-speed on-chip oscillator (LOCO): 240KHz									
Timer functions	Max. 33 extended timer functions 16-bit TPUa (12 channels), MTU3a (9 channels), GPTa (4 channels), 16-bit CMT (6 channels), 32-bit CMTW (2 channels) <i>Note: Number of channels differs on 176-pin products.</i>									
Communication functions	Ether-MAC: 1 port (switchable) USB 2.0 high-Speed Host/Function: 1 channel CAN (ISO 11898-1 compliant): Max. 2 channels SCIFA with 16-byte transmit/receive FIFO: 5 channels I²C bus interface: Max. 400Kbps transfer on 2 channels RSPIa: 4 channels SPIBSC: Ability to connect serial flash memory multi-I/O support on 1 channel <i>Note: Number of channels and number of ports differ on 176-pin products.</i>									
Memory interface	SPI: 4 channels QSPI (flash interface) with direct access from CPU SRAM interface (32-bit bus) SDRAM interface (32-bit bus) Burst ROM interface (32-bit bus)									
Encoder interface	-	Supported on R7S910011 only	-	Supported on R7S910013 only	Supported on R7S910026 only	Supported on R7S910028 only	Supported on R7S910036 only	Supported on R7S910016 only	Supported on R7S910018 only	
A/D converter	12-bit A/D converter × 2 units (unit 0: 8 channels, unit 1: 16 channels) <i>Note: Unit 0 only on 176-pin products.</i>									
DMA	16 channels × 2 units									
Other functions	On-chip temperature sensor for measuring internal temperature of chip Safety functions (register write protection, input clock oscillation stop detection, CRC, IWDtA, A/D self-diagnostics, error control module, etc.) Security functions (optional): Secure boot, JTAG lock, etc.									
Power supply voltage	3.3V (I/O block), 1.2V (internal)									
Operating temperature range	Tj = -40°C to +125°C									

All trademarks or registered trademarks are the property of their respective owners.  
ARM® and Cortex® are registered trademarks of ARM Limited (or its subsidiaries) in the EU and other countries.  
EtherCAT® is a patented technology and a registered trademark licensed from Beckhoff Automation GmbH of Germany.  
BiSS® is a registered trademark of iC-Haus GmbH.  
A-format™ is a registered trademark of Nikon Corporation.

Refer to "http://www.renesas.com/" for information on the latest and detailed sales offices.

## MOTOR CONTROLLERS FOR THREE-PHASE BLDC MOTOR CONTROL

# RAJ306000 SERIES

All-in-One Controllers Combining RL78 MCU, AFE, and Pre-Driver

### Product Features

- Support for motor drive voltages from 6V to 30V!
- On-chip 5V regulator is ideal for battery drive systems!
- Support for 500mA gate drive current, enabling industry's fastest switching control of low-RDS(on), high-Ciss MOSFETs!
- 2x voltage-boost function and dead off time adjustment function help suppress MOSFET heat generation!
- An all-in-one device in a compact 7mm-square TQFP package.
- Contributes to smaller mounting area and reduced BOM cost.
- Evaluation boards and sample software are available for enhanced ease of use.

#### 1. 500mA (max.) gate drive current for MOSFET drive.

- Supports use of low-RDS(on) MOSFETs for reduced loss, without needing external circuits.
- Supports dynamic motor control in response to load, making it possible to fully utilize the higher peak current capacity of lithium-ion batteries.

#### 2. 2x voltage-boost function and dead off time adjustment function improve drive efficiency. [35% better than previous Renesas products]

- Supports building of optimum conditions for high-side and low-side MOSFET control.
- Maintains gate voltage to provide stable MOSFET drive even in case of a momentary drop in the motor voltage or a reduction in the LIB voltage.

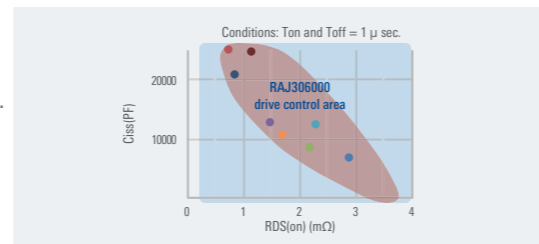

Figure 1. MOSFET Drive Control Area

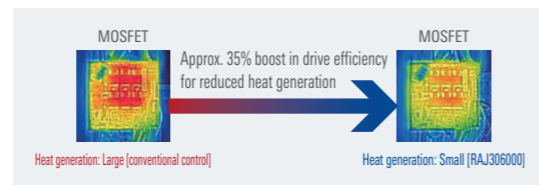
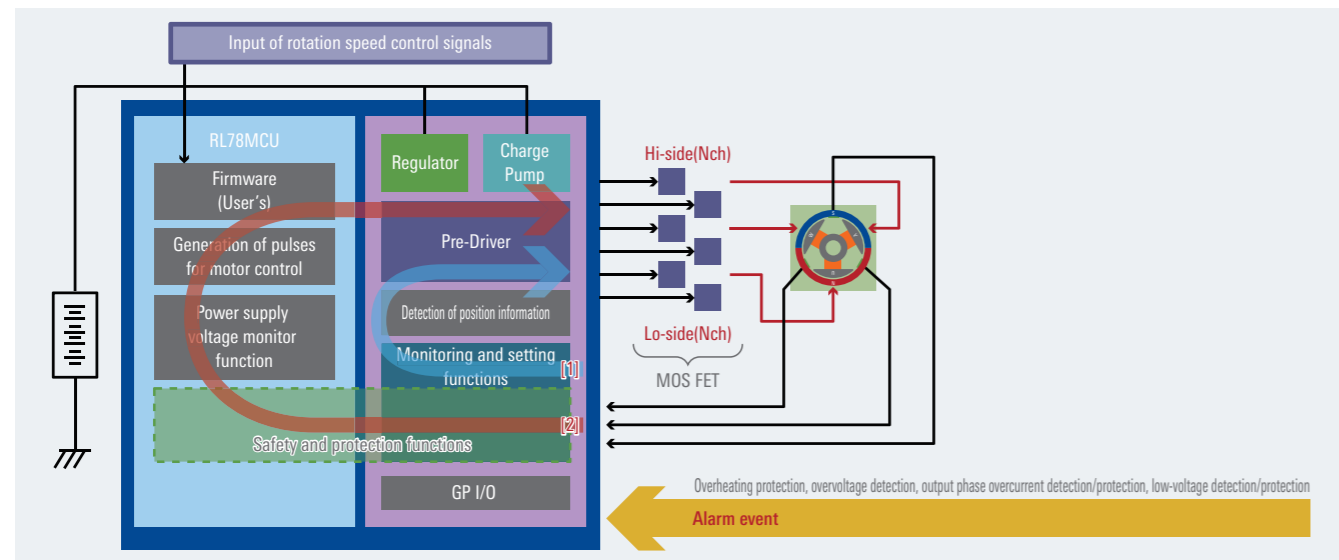

Figure 2. Thermo-Camera Images Showing MOSFET Heat Generation (Comparison With Earlier Renesas Product)

### Motor Control Safety Functions

- Malfunctions that could damage the system are shut off immediately by the AFE and pre-driver hardware. → [1]  
(Values can be specified by AFE and pre-driver register settings.)
- An on-chip circuit generates AFE and pre-driver alarm signals. This enables faster response compared with sampling by software. → [2]



### RAJ306000 Development Environment

Development tools for the RL78/G1F, including integrated development environments, compilers, and libraries, can be used without modification with the RAJ306000.

### RAJ306000 Evaluation Board

1. Includes 120-degree continuity control sample software.
2. Motor control development support tools feature a GUI and waveform display functionality.
3. The compact board (45mm-square) is populated with MOSFETs for motor drive and can be used for embedded evaluation in the actual system.
4. The power on-chip supply circuit operates as a single power supply for motor drive.

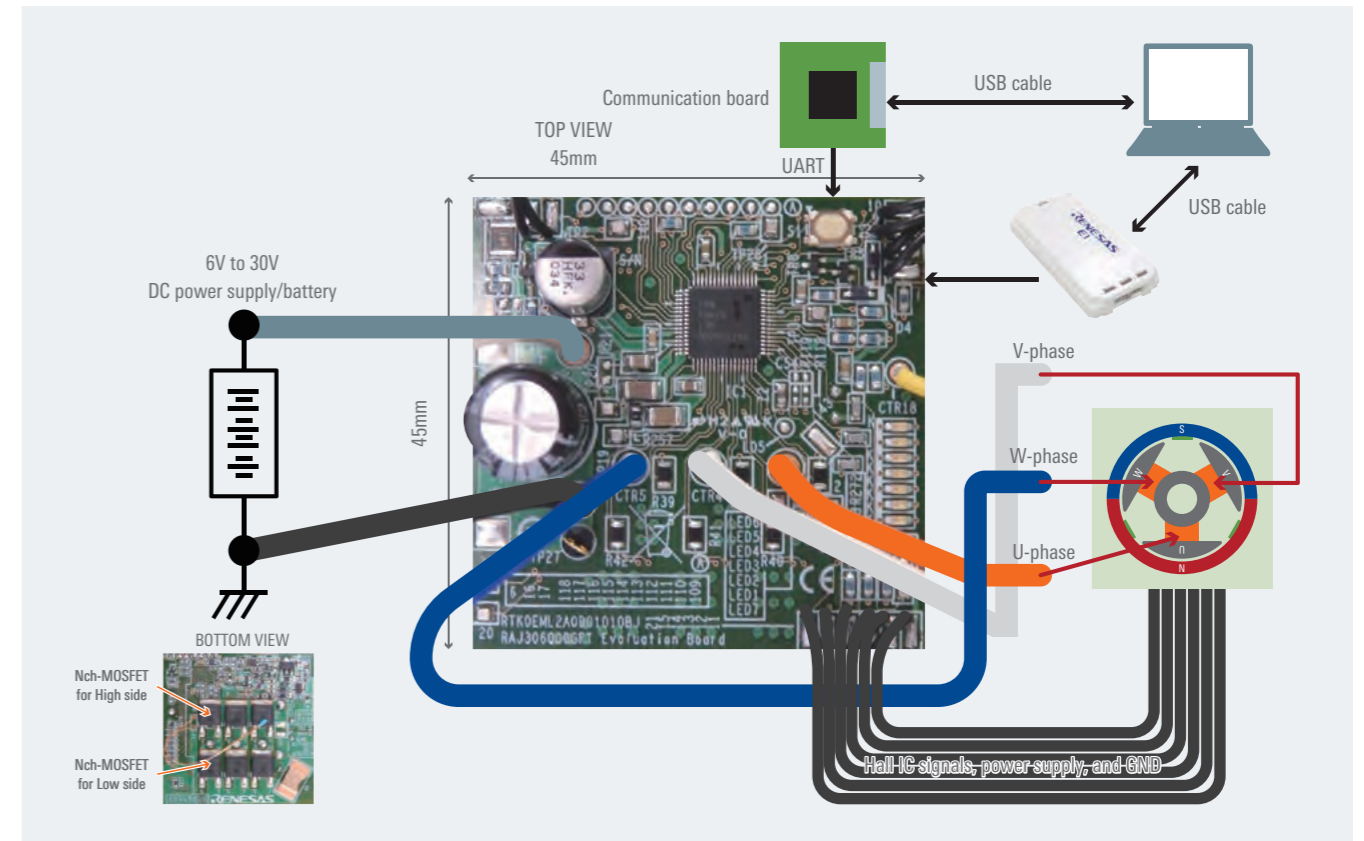

### Specifications (Under Development)

Item	RAJ306000	
Motor drive voltage	6V to 30V	
MCU	RL78G1F (Flash ROM: 64KB, RAM: 5.5KB)	
Communication interface	3 units (SPI: 2 channels, IIC: 2 channels, UART: 1 channel)	
Timers	16-bit timer: 8 channels	
5V regulator precision	5V ± 1% (Ta=25°C)	
A/D converter	9 channels (resolution: 10-bit)	
Pre-driver block	Gate drive peak current	500mA
	Voltage-boost function	2x voltage-boost/single voltage-boost, switchable
	PWM waveform modes	2 modes (PWM mode/commutation mode)
Safety functions	Overheating protection, overvoltage detection, output phase overcurrent detection/protection, low-voltage detection/protection	
Package	P-HTQFP64[JEITA] (7mm × 7mm)	

Refer to "http://www.renesas.com/" for information on the latest and detailed sales offices.

SUPPORT FOR HIGH-EFFICIENCY DRIVE AND LOW-HEAT-DISPERSION DESIGNS

# POWER MOSFETS

## Product Features

- Large-current support ( $I_d = 100A$  [ $T_a = 25^\circ C$ ])
- Low on-resistance ( $2.3m\Omega$  to  $2.75m\Omega$  (typ.)/40V voltage tolerance product)
  - > Higher system efficiency allows extended operating time and more compact heatsink and system design thanks to low heat dispersion.
- Low gate charge ( $Q_g$ ) ( $68nC$  (typ.)/40V voltage tolerance product)
  - > Reduced load on drive circuit makes for high drive efficiency, and optimization of gate devices contributes to greater compactness.
- Low- $Q_g$  products with 55V and 60V voltage tolerance are under development.

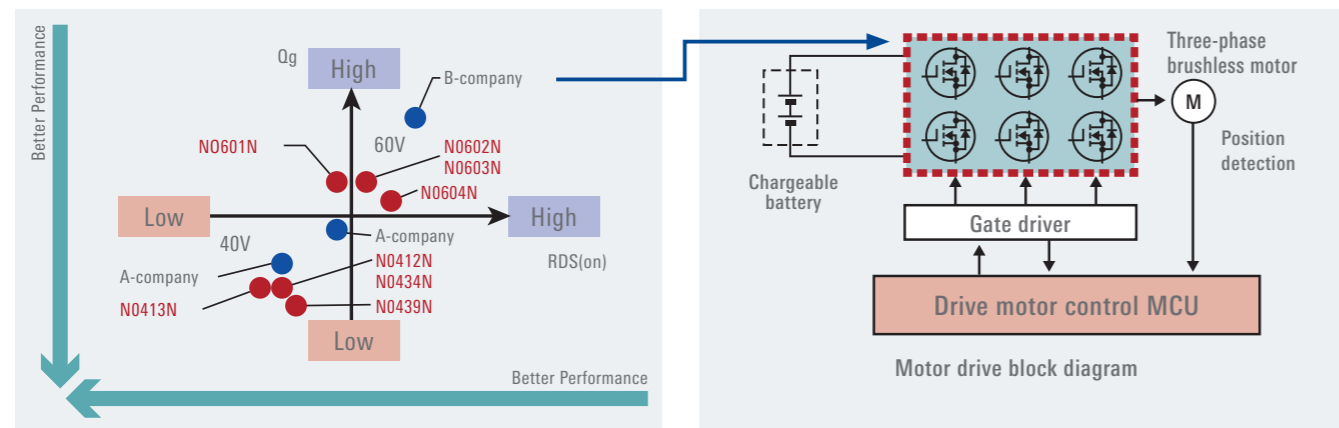

## Product Lineup

Nch MOSFET (VDSS=40 to 60V)

Note: Product numbers in parentheses ( ) are under development.

Product No.	Package	VDSS (V)	VGSS (V)	ID (A)	RDS (on) [mΩ]@10V		Qg[nC]	Ciss[pF]	WS	MP			
					Typ.	Max.							
N0413N	TO-263	40	+20/-20	100	2.3	3.3	100	5550	OK	OK			
N0412N	TO-220AB				2.7	3.7							
N0434N	TO-262				2.75	3.3							
N0439N	TO-220AB				2.75	3.3							
(N0531N)	TO-247	55	+20/-20	180	1.5	1.9	220	13000		CY4Q/2017			
(N0609N)	TO-220AB	60	+20/-20	120	2.5	3	210	11300	OK	CY4Q/2017			
N0601N	TO-263				3.3	4.2							
N0602N	TO-220AB				3.7	4.6							
N0603N	TO-262				3.7	4.6							
N0604N	TO-220AB				82	5.1					6.5	75	4150
(N0605N)	TO-220AB				80	6.8					8.5	57	3300
(N0607N)	TO-252				56	6.9					8.4	57	3280
(N0606N)	TO-220AB				60	10.7					12.9	43	2170
(N0608N)	TO-252				52	12.3					14.0	35	1910

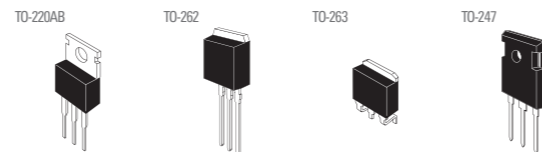

ULTRALOW-LOSS DEVICES THAT CONTRIBUTE TO REDUCED HEAT GENERATION AND GREATER COMPACTNESS

# IGBTs

## Product Features

- Advanced process technology delivers performance at the top of the industry and supports more compact designs with reduced heat generation for many product categories.
- Low loss (up to 10% less than competing products)
- High-speed switching
  - 650V voltage tolerance products: Switching frequency = 10kHz to 100kHz
  - 1250V voltage tolerance products: Switching frequency = 10kHz to 50kHz

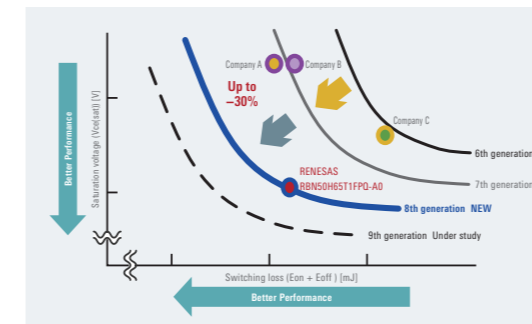

- **Ultrafine processing technology**
  - Uses the latest technology: Trench-/Field-Stop-IGBT\* configuration.
  - > Low loss combined with high speed
- **Thin-wafer processing technology**
  - Wafers only 65μm thick
  - > Reduced conduction loss

\* An IGBT configuration in which gates are buried in trenches formed on the wafer surface to weaken the electric field on the back side of the thin wafer.

## Product Roadmap

- An extensive lineup to meet the demands of many applications and fields (voltage tolerance × switching performance × load short-circuit tolerance)

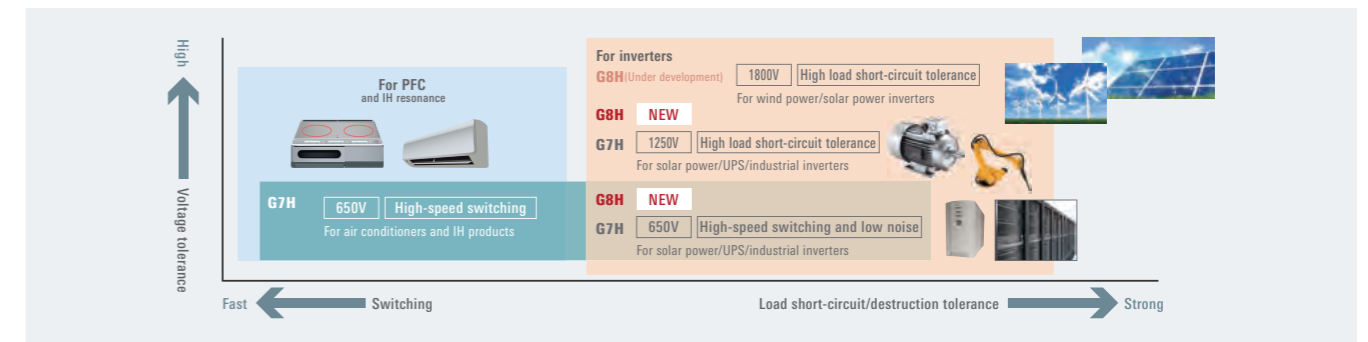

## Product Lineup

Note: Product numbers in parentheses ( ) are under development. G7H generations are listed on the Renesas website (<https://www.renesas.com/ja-jp/products/insulated-gate-bipolar-transistors/lineup.html>).

VCES (V)	IC 100C (A)	tsc (μs)	Gen	Product Category and Product No.			Package				
				IGBT+Diode	IGBT		TO-220F	TO-220ABS	TO-247	TO-3P	TO-3PF
650	40	-	G8H	(RBN40H65T1GPQ)	-	-	-	-	WS:OK MP: '17/2Q	-	-
	50	-	G8H	(RBN50H65T1GPQ)	-	-	-	-	WS:OK MP: '17/2Q	-	-
	75	-	G8H	(RBN75H65T1GPQ)	-	-	-	-	WS:OK MP: '17/2Q	-	-
1250	25	-	G8H	(RBN25H125S1GPQ)	-	-	-	-	WS:OK MP: '17/3Q	-	-
	40	10	G8H	(RBN40H125S1GPQ)	-	-	-	-	WS:OK MP: '17/3Q	-	-
	75	10	G8H	(RBN75H125S1GP4)	-	-	-	-	WS:OK MP: '17/3Q	-	*TO-247Plus

Specifications and schedules of products that are under development are subject to change without notice.

## Notice

1. Descriptions of circuits, software and other related information in this document are provided only to illustrate the operation of semiconductor products and application examples. You are fully responsible for the incorporation or any other use of the circuits, software, and information in the design of your product or system. Renesas Electronics disclaims any and all liability for any losses and damages incurred by you or third parties arising from the use of these circuits, software, or information.
  2. Renesas Electronics hereby expressly disclaims any warranties against and liability for infringement or any other disputes involving patents, copyrights, or other intellectual property rights of third parties, by or arising from the use of Renesas Electronics products or technical information described in this document, including but not limited to, the product data, drawing, chart, program, algorithm, application examples.
  3. No license, express, implied or otherwise, is granted hereby under any patents, copyrights or other intellectual property rights of Renesas Electronics or others.
  4. You shall not alter, modify, copy, or otherwise misappropriate any Renesas Electronics product, whether in whole or in part. Renesas Electronics disclaims any and all liability for any losses or damages incurred by you or third parties arising from such alteration, modification, copy or otherwise misappropriation of Renesas Electronics products.
  5. Renesas Electronics products are classified according to the following two quality grades: "Standard" and "High Quality". The intended applications for each Renesas Electronics product depends on the product's quality grade, as indicated below.  
 "Standard": Computers; office equipment; communications equipment; test and measurement equipment; audio and visual equipment; home electronic appliances; machine tools; personal electronic equipment; and industrial robots etc.  
 "High Quality": Transportation equipment (automobiles, trains, ships, etc.); traffic control (traffic lights); large-scale communication equipment; key financial terminal systems; safety control equipment; etc.  
 Renesas Electronics products are neither intended nor authorized for use in products or systems that may pose a direct threat to human life or bodily injury (artificial life support devices or systems, surgical implantations etc.), or may cause serious property damages (space and undersea repeaters; nuclear power control systems; aircraft control systems; key plant systems; military equipment, etc.). Renesas Electronics disclaims any and all liability for any damages or losses incurred by you or third parties arising from the use of any Renesas Electronics product for which the product is not intended by Renesas Electronics.
  6. When using the Renesas Electronics products, refer to the latest product information (data sheets, user's manuals, application notes, "General Notes for Handling and Using Semiconductor Devices" in the reliability handbook, etc.), and ensure that usage conditions are within the ranges specified by Renesas Electronics with respect to maximum ratings, operating power supply voltage range, heat radiation characteristics, installation, etc. Renesas Electronics disclaims any and all liability for any malfunctions or failure or accident arising out of the use of Renesas Electronics products beyond such specified ranges.
  7. Although Renesas Electronics endeavors to improve the quality and reliability of Renesas Electronics products, semiconductor products have specific characteristics such as the occurrence of failure at a certain rate and malfunctions under certain use conditions. Further, Renesas Electronics products are not subject to radiation resistance design. Please ensure to implement safety measures to guard them against the possibility of bodily injury, injury or damage caused by fire, and social damage in the event of failure or malfunction of Renesas Electronics products, such as safety design for hardware and software including but not limited to redundancy, fire control and malfunction prevention, appropriate treatment for aging degradation or any other appropriate measures by your own responsibility as warranty for your products/system. Because the evaluation of microcomputer software alone is very difficult and not practical, please evaluate the safety of the final products or systems manufactured by you.
  8. Please contact a Renesas Electronics sales office for details as to environmental matters such as the environmental compatibility of each Renesas Electronics product. Please investigate applicable laws and regulations that regulate the inclusion or use of controlled substances, including without limitation, the EU RoHS Directive carefully and sufficiently and use Renesas Electronics products in compliance with all these applicable laws and regulations. Renesas Electronics disclaims any and all liability for damages or losses occurring as a result of your noncompliance with applicable laws and regulations.
  9. Renesas Electronics products and technologies shall not be used for or incorporated into any products or systems whose manufacture, use, or sale is prohibited under any applicable domestic or foreign laws or regulations. You shall not use Renesas Electronics products or technologies for (1) any purpose relating to the development, design, manufacture, use, stockpiling, etc., of weapons of mass destruction, such as nuclear weapons, chemical weapons, or biological weapons, or missiles (including unmanned aerial vehicles (UAVs)) for delivering such weapons, (2) any purpose relating to the development, design, manufacture, or use of conventional weapons, or (3) any other purpose of disturbing international peace and security, and you shall not sell, export, lease, transfer, or release Renesas Electronics products or technologies to any third party whether directly or indirectly with knowledge or reason to know that the third party or any other party will engage in the activities described above. When exporting, selling, transferring, etc., Renesas Electronics products or technologies, you shall comply with any applicable export control laws and regulations promulgated and administered by the governments of the countries asserting jurisdiction over the parties or transactions.
  10. Please acknowledge and agree that you shall bear all the losses and damages which are incurred from the misuse or violation of the terms and conditions described in this document, including this notice, and hold Renesas Electronics harmless, if such misuse or violation results from your resale or making Renesas Electronics products available any third party.
  11. This document shall not be reprinted, reproduced or duplicated in any form, in whole or in part, without prior written consent of Renesas Electronics.
  12. Please contact a Renesas Electronics sales office if you have any questions regarding the information contained in this document or Renesas Electronics products.
- (Note 1) "Renesas Electronics" as used in this document means Renesas Electronics Corporation and also includes its majority-owned subsidiaries.  
 (Note 2) "Renesas Electronics product(s)" means any product developed or manufactured by or for Renesas Electronics.

(Rev.3.0-1 November 2016)

## SALES OFFICES

Refer to "<http://www.renesas.com/>" for the latest and detailed information.

### Renesas Electronics America Inc.

2801 Scott Boulevard Santa Clara, CA 95050-2549, U.S.A.  
 Tel: +1-408-588-6000, Fax: +1-408-588-6130

### Renesas Electronics Canada Limited

9251 Yonge Street, Suite 8309 Richmond Hill, Ontario Canada L4C 9T3  
 Tel: +1-905-237-2004

### Renesas Electronics Europe Limited

Dukes Meadow, Millboard Road, Bourne End, Buckinghamshire, SL8 5FH, U.K  
 Tel: +44-1628-585-100, Fax: +44-1628-585-900

### Renesas Electronics Europe GmbH

Arcadiastrasse 10, 40472 Düsseldorf, Germany  
 Tel: +49-211-6503-0, Fax: +49-211-6503-1327

### Renesas Electronics (China) Co., Ltd.

Room 1709, Quantum Plaza, No.27 ZhiChunLu Haidian District, Beijing 100191, P.R.China  
 Tel: +86-10-8235-1155, Fax: +86-10-8235-7679

### Renesas Electronics (Shanghai) Co., Ltd.

Unit 301, Tower A, Central Towers, 555 Langao Road, Putuo District, Shanghai, P. R. China 200333  
 Tel: +86-21-2226-0888, Fax: +86-21-2226-0999

### Renesas Electronics Hong Kong Limited

Unit 1601-1611, 16/F., Tower 2, Grand Century Place, 193 Prince Edward Road West, Mongkok, Kowloon, Hong Kong  
 Tel: +852-2265-6688, Fax: +852-2886-9022

### Renesas Electronics Taiwan Co., Ltd.

13F, No. 363, Fu Shing North Road, Taipei 10543, Taiwan  
 Tel: +886-2-8175-9600, Fax: +886-2-8175-9670

### Renesas Electronics Singapore Pte. Ltd.

80 Bondemeer Road, Unit #06-02 Hyflux Innovation Centre, Singapore 339949  
 Tel: +65-6213-0200, Fax: +65-6213-0300

### Renesas Electronics Malaysia Sdn.Bhd.

Unit 1207, Block B, Menara Amcorp, Amcorp Trade Centre, No. 18, Jln Persiaran Barat, 46050 Petaling Jaya, Selangor Darul Ehsan, Malaysia  
 Tel: +60-3-7955-9390, Fax: +60-3-7955-9510

### Renesas Electronics India Pvt. Ltd.

No.777C, 100 Feet Road, HAL II Stage, Indiranagar, Bangalore, India  
 Tel: +91-80-67208700, Fax: +91-80-67208777

### Renesas Electronics Korea Co., Ltd.

12F., 234 Teheran-ro, Gangnam-Gu, Seoul, 135-080, Korea  
 Tel: +82-2-558-3737, Fax: +82-2-558-5141