

### FEATURES

250 MHz Operation  
Driver/Comparator Included  
52-Lead LQFP Package with Built-in Heat Sink

### APPLICATIONS

Automatic Test Equipment  
Semiconductor Test Systems  
Board Test Systems  
Instrumentation and Characterization Equipment

### PRODUCT DESCRIPTION

The AD53033 is a single chip that performs the pin electronics functions of driver and comparator (D-C) in ATE VLSI and memory testers.

The driver is a proprietary design that features three active states: Data High Mode, Data Low Mode and Term Mode as well as an Inhibit State. This facilitates the implementation of high speed active termination. The output voltage range is  $-3$  V to  $+8$  V to accommodate a wide variety of test devices. The output leakage is typically less than 250 nA over the entire signal range.

The dual comparator, with an input range equal to the driver output range, features built-in latches and ECL-compatible outputs. The outputs are capable of driving  $50 \Omega$  signal lines terminated to  $-2$  V. Signal tracking capability is upwards of 5 V/ns.

Also included on the chip is an onboard temperature sensor whose purpose is to give an indication of the surface temperature of the D-C. This information can be used to measure  $\theta_{JC}$  and  $\theta_{JA}$  or flag an alarm if proper cooling is lost. Output from the

### FUNCTIONAL BLOCK DIAGRAM

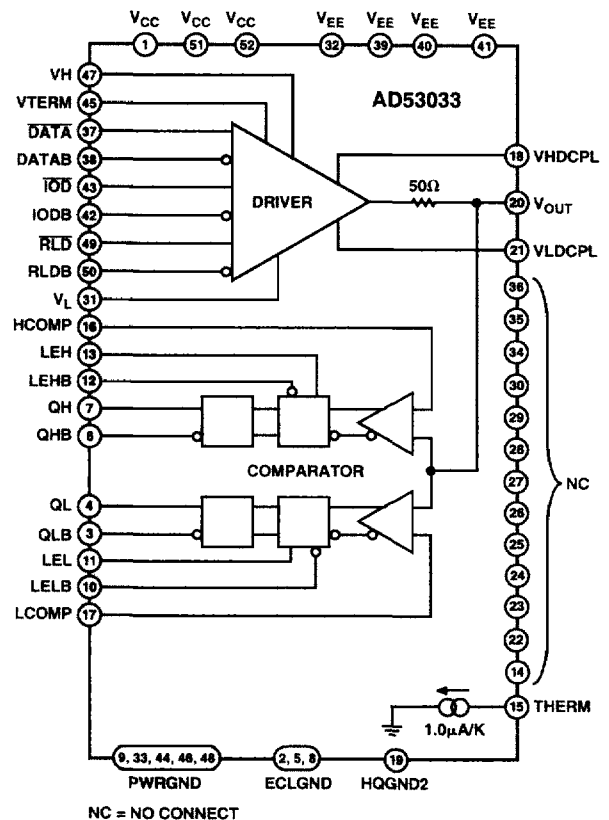

sensor is a current sink that is proportional to absolute temperature. The gain is trimmed to a nominal value of  $1.0 \mu\text{A/K}$ . As an example, the output current can be sensed by using a  $10 \text{ k}\Omega$  resistor connected from  $+10$  V to the THERM (IOUT) pin. A voltage drop across the resistor will be developed that equals:  $10\text{K} \times 1 \mu\text{A/K} = 10 \text{ mV/K} = 2.98 \text{ V}$  at room temperature.

REV. 0

Information furnished by Analog Devices is believed to be accurate and reliable. However, no responsibility is assumed by Analog Devices for its use, nor for any infringements of patents or other rights of third parties which may result from its use. No license is granted by implication or otherwise under any patent or patent rights of Analog Devices.

One Technology Way, P.O. Box 9106, Norwood, MA 02062-9106, U.S.A.  
Tel: 781/329-4700 World Wide Web Site: <http://www.analog.com>  
Fax: 781/326-8703 © Analog Devices, Inc., 1999

# AD53033—SPECIFICATIONS

## DRIVER SPECIFICATIONS

(All specifications are at  $T_1 = +85^\circ\text{C} \pm 5^\circ\text{C}$ ,  $+V_S = +12\text{ V} \pm 3\%$ ,  $-V_S = -7\text{ V} \pm 3\%$  unless otherwise noted. All temperature coefficients are measured at  $T_1 = +75^\circ\text{C}$  to  $+95^\circ\text{C}$ ). CHDCPL = CLDCPL = 39 nF.

Parameter	Min	Typ	Max	Units	Test Conditions
<b>DIFFERENTIAL INPUT CHARACTERISTICS</b> (DATA to $\overline{\text{DATA}}$ , IOD to $\overline{\text{IOD}}$ , RLD to $\overline{\text{RLD}}$ )					
Input Voltage	-2		0	V	
Differential Input Range		ECL			
Bias Current	-250		+250	$\mu\text{A}$	$V_{\text{IN}} = -2\text{ V}, 0.0\text{ V}$
<b>REFERENCE INPUTS</b>					
Bias Currents	-50		+50	$\mu\text{A}$	$V_L, V_H, V_T = 5\text{ V}$
<b>OUTPUT CHARACTERISTICS</b>					
Logic High Range	-2		8	V	DATA = H, $V_H = -2\text{ V}$ to $+8\text{ V}$ $V_L = -3\text{ V}$ ( $V_H = -2\text{ V}$ to $+6\text{ V}$ ) $V_L = -1\text{ V}$ ( $V_H = +6\text{ V}$ to $+8\text{ V}$ )
Logic Low Range	-3		5	V	DATA = L, $V_L = -3\text{ V}$ to $+5\text{ V}$ , $V_H = +6\text{ V}$
Amplitude ( $V_H$ and $V_L$ )	0.1		9	V	$V_L = 0.0\text{ V}$ , $V_H = +0.1\text{ V}$ , $V_T = 0\text{ V}$
Absolute Accuracy					$V_L = -2\text{ V}$ , $V_H = +7\text{ V}$ , $V_T = 0\text{ V}$
$V_H$ Offset	-50		+50	mV	DATA = H, $V_H = 0\text{ V}$ , $V_L = -3\text{ V}$ , $V_T = +3\text{ V}$
$V_H$ Gain + Linearity Error	0.3 - 5		+0.3 + 5	% of $V_H$ + mV	DATA = H, $V_H = -2\text{ V}$ to $+8\text{ V}$ , $V_L = -3\text{ V}$ , $V_T = +3\text{ V}$
$V_L$ Offset	-50		+50	mV	DATA = L, $V_L = -3\text{ V}$ , $V_H = +6\text{ V}$ , $V_T = +7.5\text{ V}$
$V_L$ Gain + Linearity Error	-0.3 - 5		+0.3 + 5	% of $V_L$ + mV	DATA = L, $V_L = 0\text{ V}$ , $V_H = +6\text{ V}$ , $V_T = +7.5\text{ V}$
Offset TC		0.5		$\text{mV}/^\circ\text{C}$	$V_L = 0\text{ V}$ , $V_H = +5\text{ V}$ , $V_T = 0\text{ V}$
Output Resistance					
$V_H = -2\text{ V}$	44	46	48	$\Omega$	$V_L = -3\text{ V}$ , $V_T = 0\text{ V}$ , $I_{\text{OUT}} = 0, +1, +30\text{ mA}$
$V_H = +8\text{ V}$	44	46	48	$\Omega$	$V_L = -1\text{ V}$ , $V_T = 0\text{ V}$ , $I_{\text{OUT}} = 0, -1, -30\text{ mA}$
$V_L = -3\text{ V}$	44	46	48	$\Omega$	$V_H = +6\text{ V}$ , $V_T = 0\text{ V}$ , $I_{\text{OUT}} = 0, +1, +30\text{ mA}$
$V_L = +5\text{ V}$	44	46	48	$\Omega$	$V_H = +6\text{ V}$ , $V_T = 0\text{ V}$ , $I_{\text{OUT}} = 0, -1, -30\text{ mA}$
$V_H = +3\text{ V}$		46		$\Omega$	$V_L = 0\text{ V}$ , $V_T = 0\text{ V}$ , $I_{\text{OUT}} = -30\text{ mA}$ (Trim Point)
Dynamic Current Limit	100			mA	$C_{\text{BYP}} = 39\text{ nF}$ , $V_H = +7\text{ V}$ , $V_L = -2\text{ V}$ , $V_T = 0\text{ V}$
Static Current Limit	-85		+85	mA	Output to $-3\text{ V}$ , $V_H = +8\text{ V}$ , $V_L = -1\text{ V}$ , $V_T = 0\text{ V}$ DATA = H and Output to $+8\text{ V}$ , $V_H = +6\text{ V}$ , $V_L = -3\text{ V}$ , $V_T = 0\text{ V}$ , DATA = L
<b><math>V_{\text{TERM}}</math></b>					
Voltage Range	-3		8.0	V	TERM MODE, $V_T = -3\text{ V}$ to $+8\text{ V}$ , $V_L = 0\text{ V}$ , $V_H = 3\text{ V}$
$V_{\text{TERM}}$ Offset	-50		+50	mV	TERM MODE, $V_T = 0\text{ V}$ , $V_L = 0\text{ V}$ , $V_H = 3\text{ V}$
$V_{\text{TERM}}$ Gain + Linearity Error	-0.3 + 5		+0.3 + 5	% of $V_{\text{SET}}$ + mV	TERM MODE, $V_T = -3\text{ V}$ to $+8\text{ V}$ , $V_L = 0\text{ V}$ , $V_H = 3\text{ V}$
Offset TC		0.5		$\text{mV}/^\circ\text{C}$	$V_T = 0\text{ V}$ , $V_L = 0\text{ V}$ , $V_H = 3\text{ V}$
Output Resistance	44	46	49	$\Omega$	$I_{\text{OUT}} = +30\text{ mA}, +1.0\text{ mA}$ , $V_T = -3.0\text{ V}$ , $V_H = 3\text{ V}$ , $V_L = 0\text{ V}$ $I_{\text{OUT}} = -30\text{ mA}, -1.0\text{ mA}$ , $V_T = +8.0\text{ V}$ , $V_H = 3\text{ V}$ , $V_L = 0\text{ V}$ $I_{\text{OUT}} = \pm 30\text{ mA}, \pm 1.0\text{ mA}$ , $V_T = 0\text{ V}$ , $V_H = 3\text{ V}$ , $V_L = 0\text{ V}$
<b>DYNAMIC PERFORMANCE, (<math>V_H</math> AND <math>V_L</math>)</b>					
Propagation Delay Time	1.1	1.6	2.1	ns	Measured at 50%, $V_H = +400\text{ mV}$ , $V_L = -400\text{ mV}$
Propagation Delay TC		2		$\text{ps}/^\circ\text{C}$	Measured at 50%, $V_H = +400\text{ mV}$ , $V_L = -400\text{ mV}$
Delay Matching, Edge to Edge		<100		ps	Measured at 50%, $V_H = +400\text{ mV}$ , $V_L = -400\text{ mV}$
Rise and Fall Times					
1 V Swing		0.6		ns	Measured 20%–80%, $V_L = 0\text{ V}$ , $V_H = 1\text{ V}$
3 V Swing		1.0		ns	Measured 20%–80%, $V_L = 0\text{ V}$ , $V_H = 3\text{ V}$
5 V Swing		1.7		ns	Measured 10%–90%, $V_L = 0\text{ V}$ , $V_H = 5\text{ V}$
9 V Swing		3.0		ns	Measured 10%–90%, $V_L = -2\text{ V}$ , $V_H = 7\text{ V}$
Rise and Fall Time Temperature Coefficient					
1 V Swing		$\pm 1$		$\text{ps}/^\circ\text{C}$	Measured 20%–80%, $V_L = 0\text{ V}$ , $V_H = 1\text{ V}$
3 V Swing		$\pm 2$		$\text{ps}/^\circ\text{C}$	Measured 20%–80%, $V_L = 0\text{ V}$ , $V_H = 3\text{ V}$
5 V Swing		$\pm 4$		$\text{ps}/^\circ\text{C}$	Measured 10%–90%, $V_L = 0\text{ V}$ , $V_H = 5\text{ V}$
Overshoot and Preshoot	-3.0 - 50		+3.0 + 50	% of Step + mV	$V_L, V_H = -0.1\text{ V}, 0.1\text{ V}$ , $V_L, V_H = 0.0\text{ V}, 1.0\text{ V}$ $V_L, V_H = 0.0\text{ V}, 3.0\text{ V}$ , $V_L, V_H = 0.0\text{ V}, 5.0\text{ V}$ $V_L, V_H = -2.0\text{ V}, 7.0\text{ V}$
Settling Time					
to 15 mV		<50		ns	$V_L = 0\text{ V}$ , $V_H = 0.5\text{ V}$
to 4 mV		<10		$\mu\text{s}$	$V_L = 0\text{ V}$ , $V_H = 0.5\text{ V}$

Parameter	Min	Typ	Max	Units	Test Conditions
Delay Change vs. Pulsewidth		<50		ps	$V_L = 0\text{ V}, V_H = 2\text{ V}$
Minimum Pulsewidth					
3 V Swing		2		ns	$V_L = 0\text{ V}, V_H = 3\text{ V}, 90\% \text{ Reached, Measure @ } 50\%$
5 V Swing		3		ns	$V_L = 0\text{ V}, V_H = 5\text{ V}, 90\% \text{ Reached, Measure @ } 50\%$
Toggle Rate		250		MHz	$V_L = 0\text{ V}, V_H = 5\text{ V}, VDUT > 3.0\text{ V p-p}$
<b>DYNAMIC PERFORMANCE, INHIBIT</b>					
Delay Time, Active to Inhibit	1.5		4.0	ns	Measured at 50%, $V_H = +2\text{ V}, V_L = -2\text{ V}$
Delay Time, Inhibit to Active	1.5		3.5	ns	Measured at 50%, $V_H = +2\text{ V}, V_L = -2\text{ V}$
Delay Time Matching (Z)			$\pm 2.2$	ns	Z = Delay Time Active to Inhibit Test (Above) — Delay Time Inhibit to Active Test (Above) (Of Worst Two Edges)
I/O Spike		<200		mV, p-p	$V_H = 0\text{ V}, V_L = 0\text{ V}$
Rise, Fall Time, Active to Inhibit			3.5	ns	$V_H = +2\text{ V}, V_L = -2\text{ V}$ (Measured 20%/80% of 1 V Output)
Rise, Fall Time, Inhibit to Active			2.2	ns	$V_H = +2\text{ V}, V_L = -2\text{ V}$ (Measured 20%/80% of 1 V Output)
<b>DYNAMIC PERFORMANCE, <math>V_{TERM}</math></b>					
Delay Time, $V_H$ to $V_{TERM}$			3.0	ns	Measured at 50%, $V_L = V_H = +0.4\text{ V}, V_{TERM} = -0.4\text{ V}$
Delay Time, $V_L$ to $V_{TERM}$			5.0	ns	Measured at 50%, $V_L = V_H = +0.4\text{ V}, V_{TERM} = -0.4\text{ V}$
Delay Time, $V_{TERM}$ to $V_H$ and $V_{TERM}$ to $V_L$			4.0	ns	Measured at 50%, $V_L = V_H = +0.4\text{ V}, V_{TERM} = -0.4\text{ V}$
Overshoot and Preshoot	-3.0 + 75		+3.0 + 75	% of Step + mV	$V_H/V_L, V_{TERM} = (+0.4\text{ V}, -0.4\text{ V}), (0.0\text{ V}, -2.0\text{ V}), (0.0\text{ V}, +7.0\text{ V})$
$V_{TERM}$ Mode Rise Time			4.0	ns	$V_L, V_H = 0\text{ V}, V_{TERM} = -2\text{ V}, 20\% - 80\%$
$V_{TERM}$ Mode Fall Time			5.5	ns	$V_L, V_H = 0\text{ V}, V_{TERM} = -2\text{ V}, 20\% - 80\%$
PSRR, DRIVE or TERM Mode		35		dB	$V_S = V_S \pm 3\%$

Specifications subject to change without notice.

## COMPARATOR SPECIFICATIONS

(All specifications are at  $T_J = +85^\circ\text{C} \pm 5^\circ\text{C}$ ,  $+V_S = +12\text{ V} \pm 3\%$ ,  $-V_S = -7\text{ V} = \pm 3\%$  unless otherwise noted. All temperature coefficients are measured at  $T_J = +75^\circ\text{C}$  to  $+95^\circ\text{C}$ ).

Parameter	Min	Typ	Max	Units	Test Conditions
<b>DC INPUT CHARACTERISTICS</b>					
Offset Voltage ( $V_{OS}$ )	-25		25	mV	$CMV = 0\text{ V}$
Offset Voltage (Drift)		50		$\mu\text{V}/^\circ\text{C}$	$CMV = 0\text{ V}$
HCOMP, LCOMP Bias Current	-50		50	$\mu\text{A}$	$V_{IN} = 0\text{ V}$
Voltage Range ( $V_{CM}$ )	-3		8.0	V	
Differential Voltage ( $V_{DIFF}$ )			9.0	V	
Gain and Linearity	-0.05		0.05	% FSR	$V_{IN} = -3\text{ V to } +8\text{ V}$
<b>LATCH ENABLE INPUTS</b>					
Logic "1" Current ( $I_{IH}$ )			250	$\mu\text{A}$	$LE, \overline{LE} = -0.8\text{ V}$
Logic "0" Current ( $I_{IL}$ )	-250			$\mu\text{A}$	$LE, \overline{LE} = -1.8\text{ V}$
<b>DIGITAL OUTPUTS</b>					
Logic "1" Voltage ( $V_{OH}$ )	-0.98			V	Q or $\overline{Q}$ , 50 $\Omega$ to -2 V
Logic "0" Voltage ( $V_{OL}$ )			-1.5	V	Q or $\overline{Q}$ , 50 $\Omega$ to -2 V
Slew Rate		1		V/ns	
<b>SWITCHING PERFORMANCE</b>					
Propagation Delay					
Input to Output	0.9		2.5	ns	$V_{IN} = 2\text{ V p-p},$ $HCOMP = +1\text{ V}, LCOMP = +1\text{ V}$
Latch Enable to Output		2		ns	
Propagation Delay Temperature Coefficient		2		$\text{ps}/^\circ\text{C}$	
Propagation Delay Change with Respect to					
Slew Rate: 0.5 V, 1.0 V, 3.0 V/ns		< $\pm 100$		ps	$V_{IN} = 0\text{ V to } 5\text{ V}$
Slew Rate: 5.0 V/ns		< $\pm 350$		ps	$V_{IN} = 0\text{ V to } 5\text{ V}$
Amplitude: 1.0 V, 3.0 V, 5.0 V		< $\pm 200$		ps	$V_{IN} = 1.0\text{ V/ns}$
Equivalent Input Rise Time		450		ps	$V_{IN} = 0\text{ V to } 3\text{ V}, 3\text{ V/ns}$
Pulsewidth Linearity		< $\pm 200$		ps	$V_{IN} = 0\text{ V to } 3\text{ V}, 3\text{ V/ns}, PW = 3\text{ ns} - 8\text{ ns}$
Settling Time		<25		ns	Settling to $\pm 8\text{ mV}, V_{IN} = 1\text{ V to } 0\text{ V}$
Latch Timing					
Input Pulsewidth		<1.5		ns	
Setup Time		<1.0		ns	
Hold Time		<1.0		ns	

Specifications subject to change without notice.

# AD53033—SPECIFICATIONS

## TOTAL FUNCTION SPECIFICATIONS

(All specifications are at  $T_j = +85^\circ\text{C} \pm 5^\circ\text{C}$ ,  $+V_s = +12\text{ V} \pm 3\%$ ,  $-V_s = -7\text{ V} = \pm 3\%$  unless otherwise noted. All temperature coefficients are measured at  $T_j = +75^\circ\text{C}$  to  $+95^\circ\text{C}$ ).

Parameter	Min	Typ	Max	Units	Test Conditions
<b>OUTPUT CHARACTERISTICS</b>					
Output Leakage Current, $V_{\text{OUT}} = -2\text{ V}$ to $+7\text{ V}$	-500		+500	nA	Driver INHIBITED
Output Leakage Current, $V_{\text{OUT}} = -3\text{ V}$ to $+8\text{ V}$	-2		+2	$\mu\text{A}$	
Output Capacitance		6		pF	
<b>POWER SUPPLIES</b>					
Total Supply Range		19		V	Driver = Active Driver = Active Driver = Active $R_{\text{LOAD}} = 10\text{ k}\Omega$ , $V_{\text{SOURCE}} = +10\text{ V}$
Positive Supply		12		V	
Negative Supply		-7		V	
Positive Supply Current			178	mA	
Negative Supply Current			195	mA	
Total Power Dissipation			3.5	W	
Temperature Sensor Gain Factor	0.7	1	1.4	$\mu\text{A/K}$	

### NOTES

Connecting or shorting the decoupling pins to ground will result in the destruction of the device.

Specifications subject to change without notice.

**Table I. Driver Truth Table**

DATA	$\overline{\text{DATA}}$	IOD	$\overline{\text{IOD}}$	RLD	$\overline{\text{RLD}}$	OUTPUT STATE
0	1	1	0	X	X	VL
1	0	1	0	X	X	VH
X	X	0	1	0	1	INH
X	X	0	1	1	0	VTERM

**Table II. Comparator Truth Table**

$V_{\text{OUT}}$		LEH	$\overline{\text{LEH}}$	LEL	$\overline{\text{LEL}}$	OUTPUT STATES			
						QH	$\overline{\text{QH}}$	QL	$\overline{\text{QL}}$
>HCOMP	>LCOMP	1	0	1	0	1	0	1	0
>HCOMP	<LCOMP	1	0	1	0	1	0	0	1
<HCOMP	>LCOMP	1	0	1	0	0	1	1	0
<HCOMP	<LCOMP	1	0	1	0	0	1	0	1
X	X	0	1	0	1	QH (t-1)	$\overline{\text{QH}}$ (t-1)	QL (t-1)	$\overline{\text{QL}}$ (t-1)

## ABSOLUTE MAXIMUM RATINGS<sup>1</sup>

Power Supply Voltage	
+V <sub>S</sub> to GND	+13 V
-V <sub>S</sub> to GND	-8 V
+V <sub>S</sub> to -V <sub>S</sub>	+20 V
PWR GND to ECL GND or HQ GND	±0.4 V
Inputs	
DATA, $\overline{\text{DATA}}$ , IOD, $\overline{\text{IOD}}$ , RLD, $\overline{\text{RLD}}$	+5 V, -3 V
DATA to $\overline{\text{DATA}}$ , IOD to $\overline{\text{IOD}}$ , RLD to $\overline{\text{RLD}}$	±3 V
LEL, $\overline{\text{LEL}}$ , LEH, $\overline{\text{LEH}}$	+5 V, -3 V
LEL to $\overline{\text{LEL}}$ , LEH to $\overline{\text{LEH}}$	±3 V
VH, VL, VTERM to GND	+9 V, -4 V
VH to VL	±11 V
(VH - VTERM) and (VTERM - VL)	±11 V
HCOMP	+9 V, -4 V
LCOMP	+9 V, -4 V
HCOMP, LCOMP to V <sub>OUT</sub>	±11 V
Outputs	
V <sub>OUT</sub> Short Circuit Duration	Indefinite <sup>2</sup>
V <sub>OUT</sub> Inhibit Mode	+9 V, -4 V
VHDCPL	Do Not Connect Except for Cap to V <sub>CC</sub>
VLDCPL	Do Not Connect Except for Cap to V <sub>EE</sub>
QH, $\overline{\text{QH}}$ , QL, $\overline{\text{QL}}$ Maximum I <sub>OUT</sub>	
Continuous	50 mA
Surge	100 mA
THERM	+13 V, 0 V

## Environmental

Operating Temperature (Junction)	+175°C
Storage Temperature	-65°C to +150°C
Lead Temperature (Soldering, 10 sec) <sup>3</sup>	+260°C

## NOTES

<sup>1</sup>Stresses above those listed under Absolute Maximum Ratings may cause permanent damage to the device. This is a stress rating only; functional operation of the device at these or any other conditions above those indicated in the operational sections of this specification is not implied. Absolute maximum limits apply individually, not in combination. Exposure to absolute maximum rating conditions for extended periods may affect device reliability.

<sup>2</sup>Output short circuit protection to ground is guaranteed as long as proper heat sinking is employed to ensure compliance with the operating temperature limits.

<sup>3</sup>To ensure lead coplanarity (±0.002 inches) and solderability, handling with bare hands should be avoided and the device should be stored in environments at 24°C ±5°C (75°F ± 10°F) with relative humidity not to exceed 65%.

**Table III. Package Thermal Characteristics**

Air Flow, FM	θ <sub>JA</sub> , °C/W
0	33
200	25
400	22

## ORDERING GUIDE

Model	Package Description	Shipment Method Quantity per Shipping Container	Package Option
AD53033JSTP	52-Lead LQFP-EDQUAD	90	SQ-52

## CAUTION

ESD (electrostatic discharge) sensitive device. Electrostatic charges as high as 4000 V readily accumulate on the human body and test equipment and can discharge without detection. Although the AD53033 features proprietary ESD protection circuitry, permanent damage may occur on devices subjected to high energy electrostatic discharges. Therefore, proper ESD precautions are recommended to avoid performance degradation or loss of functionality.



# AD53033

## PIN CONFIGURATION

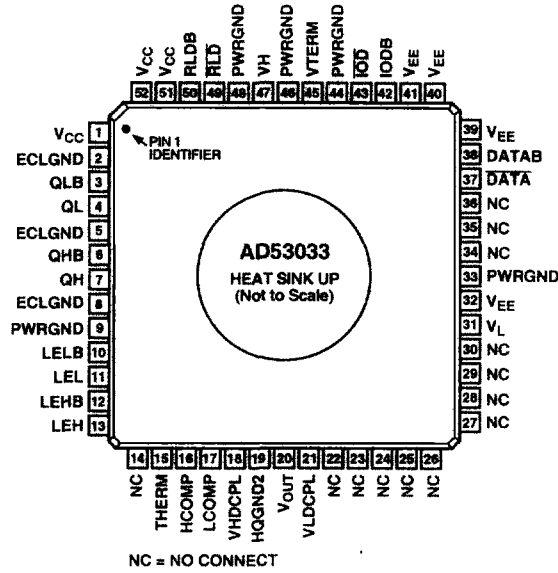

## OUTLINE DIMENSIONS

Dimensions shown in inches and (mm).

### 52-Lead LQFP-EDQUAD with Integral Heat Slug (SQ-52)

