



Serial Output 5.6 μ s 12-Bit A/D Converter

MAX170

General Description

The MAX170 is a complete CMOS 12-bit A/D converter that combines high speed and accurate performance with a cost and space saving serial interface in an 8-lead DIP or 16-lead surface mount SO package. It uses a high speed DAC and an accurate comparator in a successive approximation loop to achieve a 5.6 μ s conversion time. An on-chip buried-zener reference provides low-drift performance over the full temperature range.

External components are limited only to supply and reference decoupling capacitors. The CLOCK input can be driven from an external clock source such as a divided-down microprocessor clock. The MAX170 works with +5V and -12V to -15V supply voltages, typically dissipating 135mW.

The MAX170 is designed to work with general purpose serial-to-parallel converters, such as the 74HC595. It can also be used with digital-signal-processors such as the TMS32020, TMS320C25, NEC μ PD7720 or the DSP56000. The MAX170 has a three-wire interface that serially outputs a leading one, followed by 12 data bits (MSB first)

When the MAX170 is used with an external sample-and-hold amplifier, a maximum sampling rate of 125kHz is possible.

Applications

- Telecommunication
- Digital Signal Processing (DSP)
- Sonar/Radar Signal Processing
- Isolated Industrial Data Acquisition

Functional Diagram

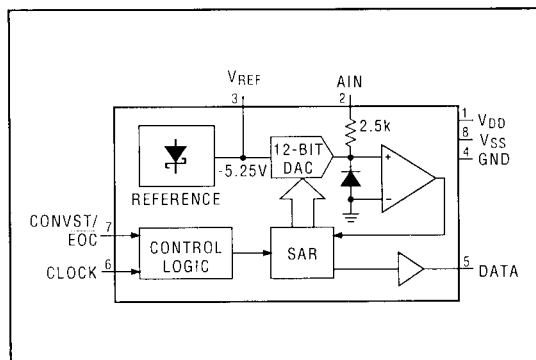

Features

- ◆ 12-Bit Resolution and Linearity
- ◆ 5.6 μ s Fast Conversion Time
- ◆ Serial Output
- ◆ Self-Start Mode
- ◆ Complete with On-Chip Reference
- ◆ Low Power (135mW)
- ◆ Easy to Opto- or Transformer-Isolate
- ◆ Small Footprint 8-Lead DIP, 16-Lead SO

Ordering Information

PART	TEMP. RANGE	PACKAGE	ERROR
MAX170CCPA	0°C to +70°C	Plastic DIP	$\pm 1/2$ LSB
MAX170DCPA	0°C to +70°C	Plastic DIP	± 1 LSB
MAX170CCWE	0°C to +70°C	Wide SO	$\pm 1/2$ LSB
MAX170DCWE	0°C to +70°C	Wide SO	± 1 LSB
MAX170DC/D	0°C to +70°C	Dice	± 1 LSB
MAX170CEPA	-40°C to +85°C	Plastic DIP	$\pm 1/2$ LSB
MAX170DEPA	-40°C to +85°C	Plastic DIP	± 1 LSB
MAX170CEWE	-40°C to +85°C	Wide SO	$\pm 1/2$ LSB
MAX170DEWE	-40°C to +85°C	Wide SO	± 1 LSB
MAX170CMJA	-55°C to +125°C	CERDIP	$\pm 1/2$ LSB
MAX170DMJA	-55°C to +125°C	CERDIP	± 1 LSB

All DIP packages are 8 leads; all SO packages are 16 leads.
Contact factory for "A" and "B" grades.

Pin Configurations

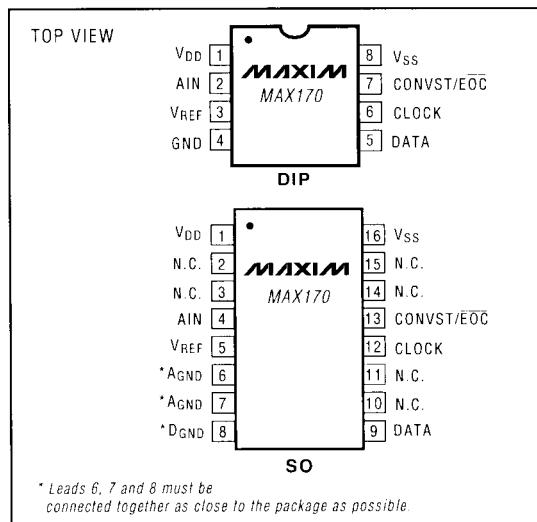

Maxim Integrated Products 1

Call toll free 1-800-998-8800 for free samples or literature.

Serial Output 5.6 μ s 12-Bit A/D Converter

ABSOLUTE MAXIMUM RATINGS

V _{DD} to GND	-0.3 to +7V
V _{SS} to GND	+0.3V to -17V
A _{IN} to AGND	±15V
Digital Input Voltage to GND (Pins 6, 7, DIP)	-0.3V, V _{DD} +0.3V
Digital Output Voltage to GND (Pin 5, DIP)	-0.3V, V _{DD} +0.3V

Operating Temperature Ranges

MAX170XC	0°C to +70°C
MAX170XE	-40°C to +85°C
MAX170XM	-55°C to +120°C
Storage Temperature Range	-65°C to +160°C
Power Dissipation (any package) to +70°C	500mW
Derates Above +75°C by	6.25mW/°C
Lead Temperature (Soldering 10 seconds)	+300°C

Stresses beyond those listed under "Absolute Maximum Ratings" may cause permanent damage to the device. These are stress ratings only, and functional operation of the device at these or any other conditions above those indicated in the operational sections of the specifications is not implied. Exposure to absolute maximum rating conditions for extended periods may affect device reliability.

ELECTRICAL CHARACTERISTICS

(V_{DD} = +5V ±5%, V_{SS} = -11.4V to -15.75V; f_{CLK} = 2.5MHz; T_A = T_{MIN} to T_{MAX}, unless otherwise noted.)

PARAMETER	SYMBOL	CONDITIONS	MIN	TYP	MAX	UNITS
ACCURACY						
Resolution			12			Bits
Integral Nonlinearity	INL	T _A = 25°C MAX170C MAX170CC/CE MAX170CM MAX170D			±1/2 ±1/2 ±3/4 ±1	LSB
Differential Nonlinearity	DNL	Guaranteed Monotonic Over Temperature			±1	LSB
Offset Error (Note 1)		MAX170C MAX170D			+4 ±5	LSB
Full Scale Error (Note 2)		T _A = 25°C			±10	LSB
Full Scale Tempco (Notes 3,4)		MAX170C MAX170D			±25 ±45	ppm/°C
Conversion Time	t _{CONV}	14 Clock Cycles			5.6	μs
ANALOG INPUT						
Input Voltage Range			0		+5	V
Input Current		A _{IN} = 0V to +5V			3.5	mA
INTERNAL REFERENCE						
V _{REF} Output Voltage		T _A = 25°C	-5.2	-5.25	-5.3	V
V _{REF} Output Tempco (Note 5)		MAX170C MAX170D			±20 ±40	ppm/°C
Output Current Sink Capability		(Note 6)			5	mA
POWER SUPPLY REJECTION						
Positive Supply Rejection	V _{DD}	FS Change, V _{SS} = -15V or -12V, V _{DD} = 4.75V to 5.25V			±1/2	LSB
Negative Supply Rejection	V _{SS}	FS Change, V _{SS} = -14.25V to -15.75V, V _{DD} = +5V, V _{SS} = -11.4V to -12.6V			±1/8 ±1/8	LSB
LOGIC INPUTS						
Input Low Voltage	V _{IL}				0.8	V
Input High Voltage	V _{IH}		2.4			V
Input Capacitance (Note 7)	C _{IN}				10	pF
Input Current	I _{IN}	A _{IN} = 0 to V _{DD} CLOCK, CONVST/EOC	+200		+10 ±500	μA

Serial Output 5.6μs 12-Bit A/D Converter

MAX170

ELECTRICAL CHARACTERISTICS (continued)

($V_{DD} = +5V \pm 5\%$, $V_{SS} = -11.4V$ to $-15.75V$; $f_{CLK} = 2.5MHz$; $T_A = T_{MIN}$ to T_{MAX} unless otherwise noted.)

PARAMETER	SYMBOL	CONDITIONS	MIN	TYP	MAX	UNITS
LOGIC OUTPUT						
Output Low Voltage	V_{OL}	DATA $I_{SINK} = 1.6mA$			0.4	V
		DATA $I_{SINK} = 6.0mA$		0.3	1.5	
Output High Voltage	V_{OH}	DATA $I_{SOURCE} = 200\mu A$	4			V
POWER REQUIREMENTS						
Positive Supply Voltage	V_{DD}	$\pm 5\%$ for Specified Performance		5		V
Negative Supply Voltage (Note 8)	V_{SS}	$\pm 5\%$ for Specified Performance		-15 to -12		V
Positive Supply Current	I_{DD}	CONVST/EOC = V_{DD} , AIN = 0V		5	8	mA
Negative Supply Current	I_{SS}	CONVST/EOC = V_{DD} , AIN = 0V		-6	-11	mA
Power Dissipation		$V_{DD} = +5V$, $V_{SS} = -15V$		115	205	mW
TIMING CHARACTERISTICS (Note 9)						
($V_{DD} = +5V$, $V_{SS} = -12V$ or $-15V$; $T_A = T_{MIN}$ to T_{MAX})						
CLOCK Pulse Width	t_{CH} t_{CL}	CLOCK HIGH	40			ns
		CLOCK LOW	60			
CONVST/EOC Pulse Width	t_{SH} t_{SL}	CONVST/EOC HIGH	40			ns
		CONVST/EOC LOW	60			
CONVST/EOC to CLOCK Skew	t_{SC0} t_{SC1}	Leading CLOCK Leading CLOCK + 1	275		50	ns
CLOCK to DATA Delay	t_{PD}		25		155	ns

Note 1: Typical change over temp is +1 LSB.

Note 2: FS = +5.000V. Ideal last code transition = FS - 3/2 LSB. Adjusted for offset error.

Note 3: Full Scale Tempco = $\Delta FS / \Delta T$, where ΔFS is full scale change from $T_A = 25^\circ C$ to T_{MIN} or T_{MAX} .

Note 4: Includes internal reference drift.

Note 5: V_{REF} Tempco = $\Delta V_{REF} / \Delta T$, where ΔV_{REF} is reference voltage change from $T_A = 25^\circ C$ to T_{MIN} or T_{MAX} .

Note 6: Output current should not change during conversion.

Note 7: Guaranteed by design, not subject to test.

Note 8: Specified performance with -12V supply is guaranteed by testing offset and full scale errors.

Note 9: Timing specifications are sample tested at $25^\circ C$ to ensure compliance. All input control signals are specified with $t_r = t_f = 5ns$ (10% to 90% of +5V) and timed from a voltage level of +1.6V.

Converter Operation

The MAX170 uses a successive approximation technique to convert an unknown analog input to a 12-bit digital output code. The digital interface requires only three digital lines. Most applications require only a few external passive components to perform the analog-to-digital function. Figure 1 shows the MAX170 in its simplest operational configuration.

Figure 2 shows the MAX170 analog equivalent circuit. The internal voltage output digital-to-analog converter (DAC) is controlled by a successive approximation register (SAR) and has an output impedance of 2.5kΩ. The analog input is connected to the DAC output with a 2.5kΩ resistor. The comparator is essentially a zero-crossing detector with its output feeding back to the SAR input.

Timing and Control

The MAX170 can be used in two different modes: Forced-Start Mode requires an external conversion start

signal to initiate the conversions. Self-Start Mode uses an internally generated conversion start signal and causes the MAX170 to convert continuously.

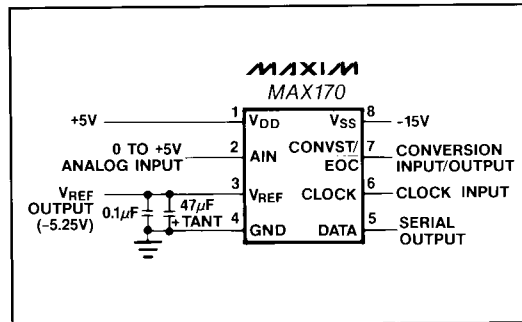

Figure 1. MAX170 Operational Diagram

Serial Output 5.6μs 12-Bit A/D Converter

Pin Description

PIN DIP	SO	NAME	FUNCTION
1	1	V _{DD}	Positive Supply, +5V
2	4	AIN	Analog Input, 0V to +5V Unipolar
3	5	V _{REF}	Reference Voltage Output, -5.25V
	6,7	AGND	Analog Ground. Must be tied to the GND pin.
4	8	GND	Ground
5	9	DATA	Serial Data Output
6	12	CLOCK	Clock Input, TTL/+5V CMOS compatible.
7	13	CONVST/EOC	Conversion Start Input for three-wire mode; End-of-Conversion output for two-wire mode.
8	16	V _{SS}	Negative Supply, -12V or -15V

Forced-Start Mode

A conversion cycle is initiated on the rising edge of the conversion start signal (CONVST/EOC) that is coincident with a falling edge of the CLOCK signal. Figure 3 shows a single conversion cycle with a continuous CLOCK. Once started, a conversion cannot be stopped and transitions at the CONVST/EOC input have no effect until the current conversion is completed (minimum of 14 clock cycles from the last rising edge of the conversion start signal).

The conversion start transition causes the SAR to set B11 (MSB) which drives the DAC output to half-scale. The analog input is compared to this value from the time of the conversion start transition until the second falling edge of CLOCK which latches the MSB result and sets the SAR to compare the next bit. The MSB result appears at the DATA output after a delay T_{PD} from the falling edge of CLOCK. Each subsequent bit conversion proceeds similarly until all 12 bits of the DAC have been tried. Conversion is completed at the falling edge of the 13th CLOCK cycle. The DATA output returns high at the falling edge of the 14th CLOCK cycle and remains so until the next conversion sends out its MSB result.

The next conversions can be started on the 14th CLOCK cycle of a previous conversion as shown in Figure 4. This results in the maximum throughput rate of one conversion per 14 CLOCK cycles.

Conversion start transitions must arrive within the setup limits t_{SC0} and t_{SC1} relative to the falling edges of the CLOCK signal to guarantee that the serial DATA output stream will start at the second CLOCK cycle, as shown in Figure 4. Limits t_{SC0} and t_{SC1} apply whether conversion is started directly after a previous cycle on the 14th CLOCK, or if idle CLOCK pulses exist between conversions. Note that bringing CONVST/EOC input high on the falling edge of CLOCK 14 allows the maximum time for the internal DAC to settle.

It is possible to operate the MAX170 at a higher or lower clock rate than specified. At higher than 2.5MHz clock rates, the INL will degrade as shown in Figure 5. But at lower speeds, there will be no degradation of the INL.

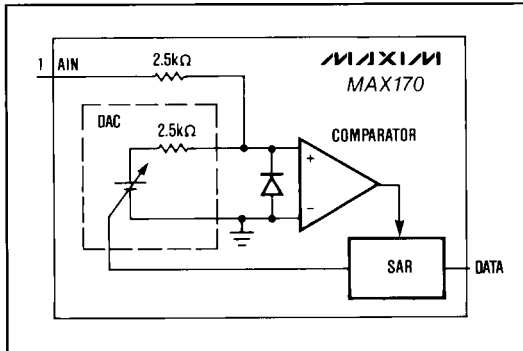

Figure 2. MAX170 Analog Equivalent Circuit

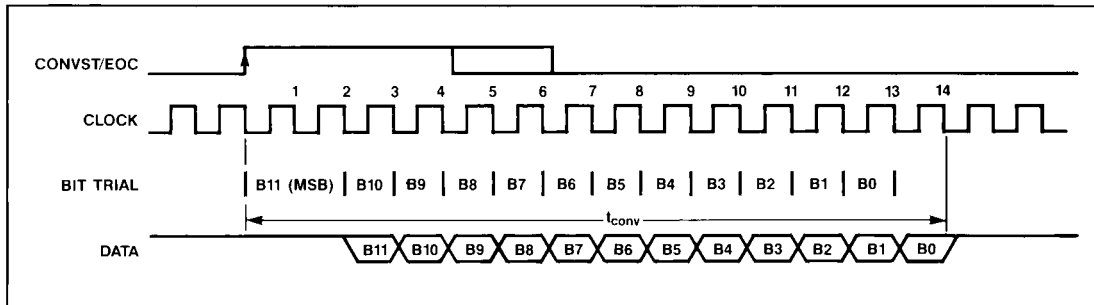

Figure 3. Forced-Start Mode Timing (14 Clocks Per Conversion Cycle)

Serial Output 5.6μs 12-Bit A/D Converter

MAX170

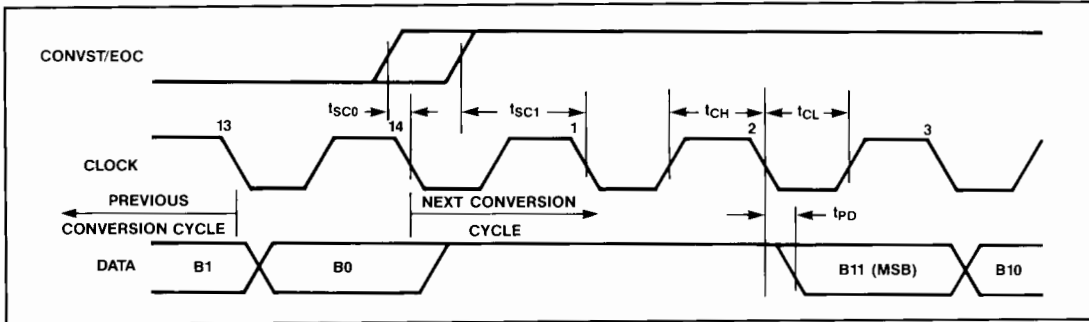

Figure 4. MAX170 Timing Diagram

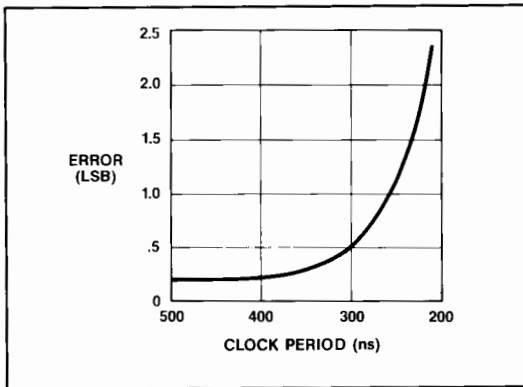

Figure 5. Typical INL vs Clock Rate for MAX170

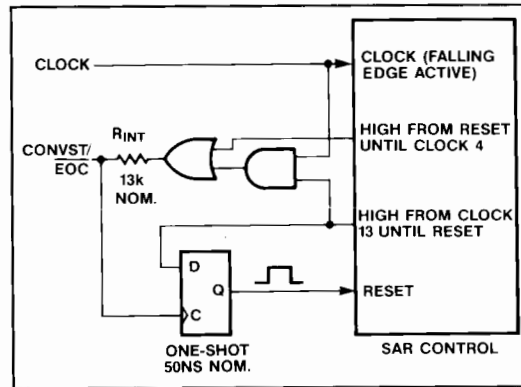

Figure 6. MAX170 Logic Equivalent for Start and Clock Inputs

Self-Start Mode

The CONVST/EOC pin is internally driven by a conversion complete signal through a 13kΩ (typical value) resistor, R_{INT} (Figure 6). By leaving this pin open-circuited, the MAX170 will generate its own conversion start input and run at a rate of one conversion for every 13 CLOCK cycles. The signal at the CONVST/EOC pin can be buffered and used as a framing signal to synchronize the serial data (Figure 7).

The CLOCK rate in the self-start mode will be limited by capacitive loading of the CONVST/EOC pin. Therefore, no more than one HCMOS logic input and a minimum of PC board capacitance should be connected to this pin when high speed conversions are desired. The maximum CLOCK rate for this mode will be limited by the requirement that the conversion start signal must cross the logic high threshold ($V_{IH} = 2.4V$) of this input at least 200ns before the falling edge of the first clock cycle (t_{SC1}).

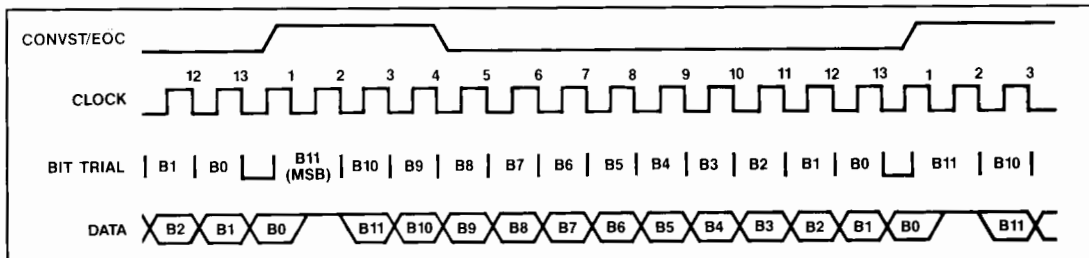

Figure 7. Self-Start Mode Timing (13 Clocks Per Conversion Cycle)

Serial Output 5.6μs 12-Bit A/D Converter

For instance, a minimal buffer circuit of one HCMOS gate input (10pF) connected to the CONVST/EOC pin and 15pF of PC board capacitance result in a total load of 25pF. Since the CONVST/EOC pin is internally driven high through the R_{INT} during the 13th clock period, an R-C charging delay results. (The value of R_{INT} depends on process variations, and can have a maximum value of 17kΩ.) The R-C delay plus the 200ns required setup time cannot exceed the half-period of the CLOCK signal. Assuming a 50% duty cycle, the maximum CLOCK frequency that can be used in the self-start mode would be:

$$f_{CLOCK} (MAX) = 1 / (2 (0.7 R_{INT} C_{LOAD} + 200ns)) = 1MHz$$

with $R_{INT} = 17k\Omega$, and $C_{LOAD} = 25pF$.

Output Coding

The data output from MAX170 is in the Straight Binary Code. Other common binary codes, such as 2's complement, offset binary or complementary codes, can be obtained by inverting either the serial data, or the proper bit(s) of the parallel data in software or hardware.

Applications

Unipolar Input Operation

Figure 8 shows the nominal input/output transfer function of the MAX170. Code transitions occur halfway between successive integer LSB values. The output coding is binary with $1LSB = 1.22mV$ ($5V/4096$).

Offset and Full Scale Adjustment

In applications where the offset and full scale range have to be adjusted for the ADC, use the circuit shown in Figure 9. Note that the amplifier shown could also have been a sample-and-hold. The offset should be adjusted first. Apply 1/2 LSB (0.61mV) at the analog input and adjust the offset of the amplifier until the digital output code changes between 0000 0000 0000 and 0000 0000 0001.

To adjust the full scale range, apply $FS - 3/2LSB$ (4.9817V) at the analog input and adjust R1 until the output code changes between 1111 1111 1110 and 1111 1111 1111.

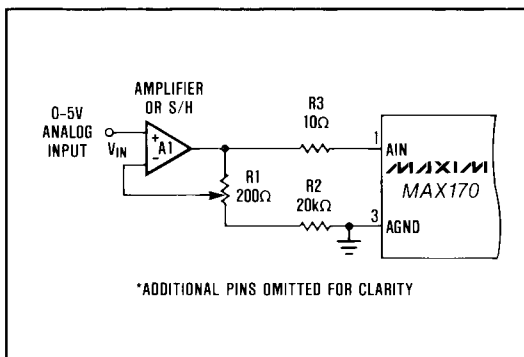

Figure 9. Full-Scale Adjustment

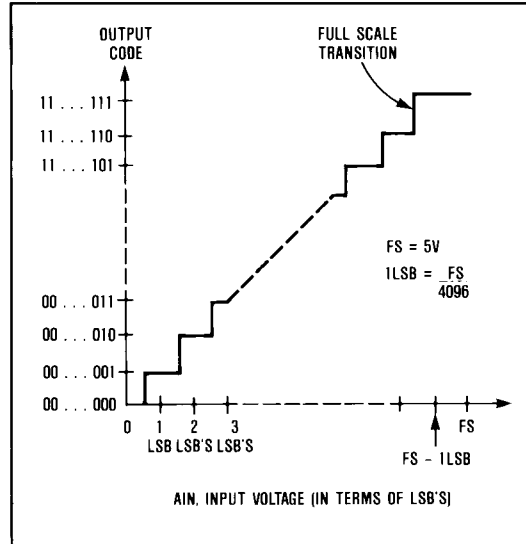

Figure 8. MAX170 Transfer Function

Bipolar Input Operation

Bipolar operation can be achieved in two modes: non-inverting and inverting. For both cases the amplifier shown in the circuits can be replaced by the AD585 or HA5320 sample-and-hold amplifiers. Several different input ranges are possible by selecting the values for the scaling resistors as shown in Tables 1 and 2.

Figure 10 shows the bipolar operation in the non-inverting mode, where the output coding is offset binary. Figure 11 shows the ideal transfer function for this mode.

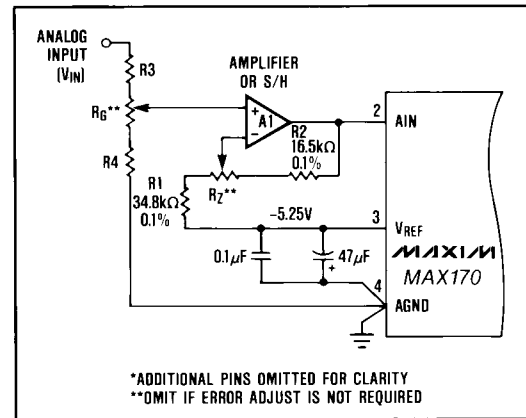

Figure 10. MAX170 Non-Inverting Bipolar Operation

Serial Output 5.6 μ s 12-Bit A/D Converter

Figure 13 shows the MAX170 to AD585 sample-and-hold interface circuit. In this example the analog input range is ± 2.5 V but other voltage ranges can also be configured.

The maximum sampling rate is 125kHz with a 2.5MHz clock and 64.5kHz with a 1MHz clock allowing for a 3 μ s sample-and-hold acquisition time. At the 2.5MHz clock rate a faster sample-and-hold amplifier, such as the HA-5320, is recommended (Figure 14).

MAX170 in Remote Applications

Figure 15 shows a MAX170 operating in the self-start mode with a three-wire digital interface to a 12-bit parallel output port. The analog input is referenced to signal ground at the GND pin of the MAX170. CMOS inverters isolate the CONVST/EOC pin from the capacitive load of the wire interface and the multiple register inputs. The parallel data outputs are updated at the rising edge of the DATA VALID signal.

MAX170 with Opto-Isolators

Serial interface simplifies opto-coupled or transformer-coupled A/D converter applications. For example, transducer outputs often require electrical isolation to separate the control electronics from hazardous electrical conditions, provide noise immunity or bridge large differences in ground potential. Isolation amplifiers that are typically used for accomplishing this cost up to \$100 per channel. The MAX170 provides a low cost alternative to isolation amplifiers, and it performs the A/D conversion as well (Figure 16A). The A/D converter results are transmitted across a 1500V isolation barrier provided by three 6N136 optical isolators. 74HC595 3-statable shift registers then reconstruct a 12-bit parallel data output. Figure 16B shows the timing diagram for this application. The conversion speed is limited by the speed of the opto-isolators, and with a 140kHz clock conversion time is 100 μ s. For those who prefer even greater space savings, Maxim's MAX171 that combines the MAX170, three opto-isolators and load resistors in a 16-lead DIP package, is recommended.

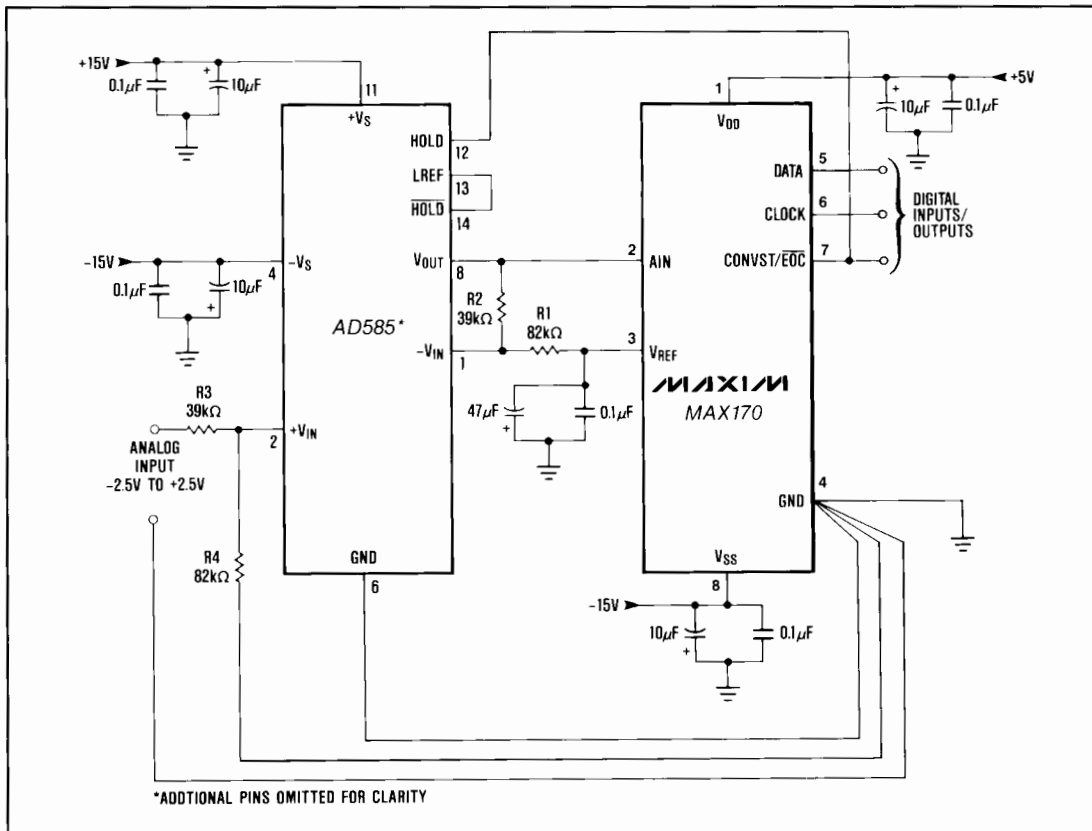

Figure 13. MAX170-AD585 Sample-and-Hold Interface

Serial Output 5.6 μ s 12-Bit A/D Converter

MAX170

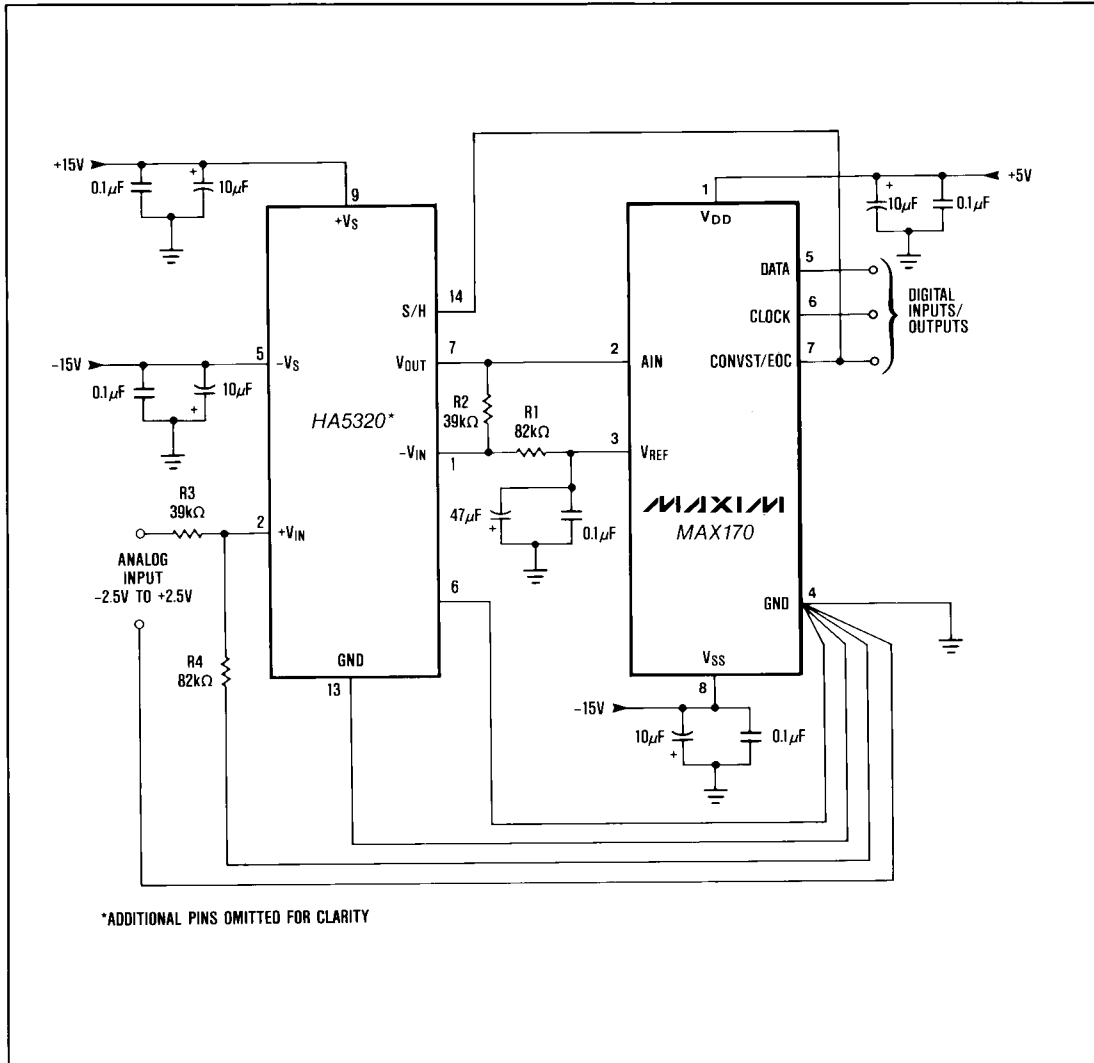

Figure 14. MAX170-HA5320 Sample-and-Hold Interface

Serial Output 5.6μs 12-Bit A/D Converter

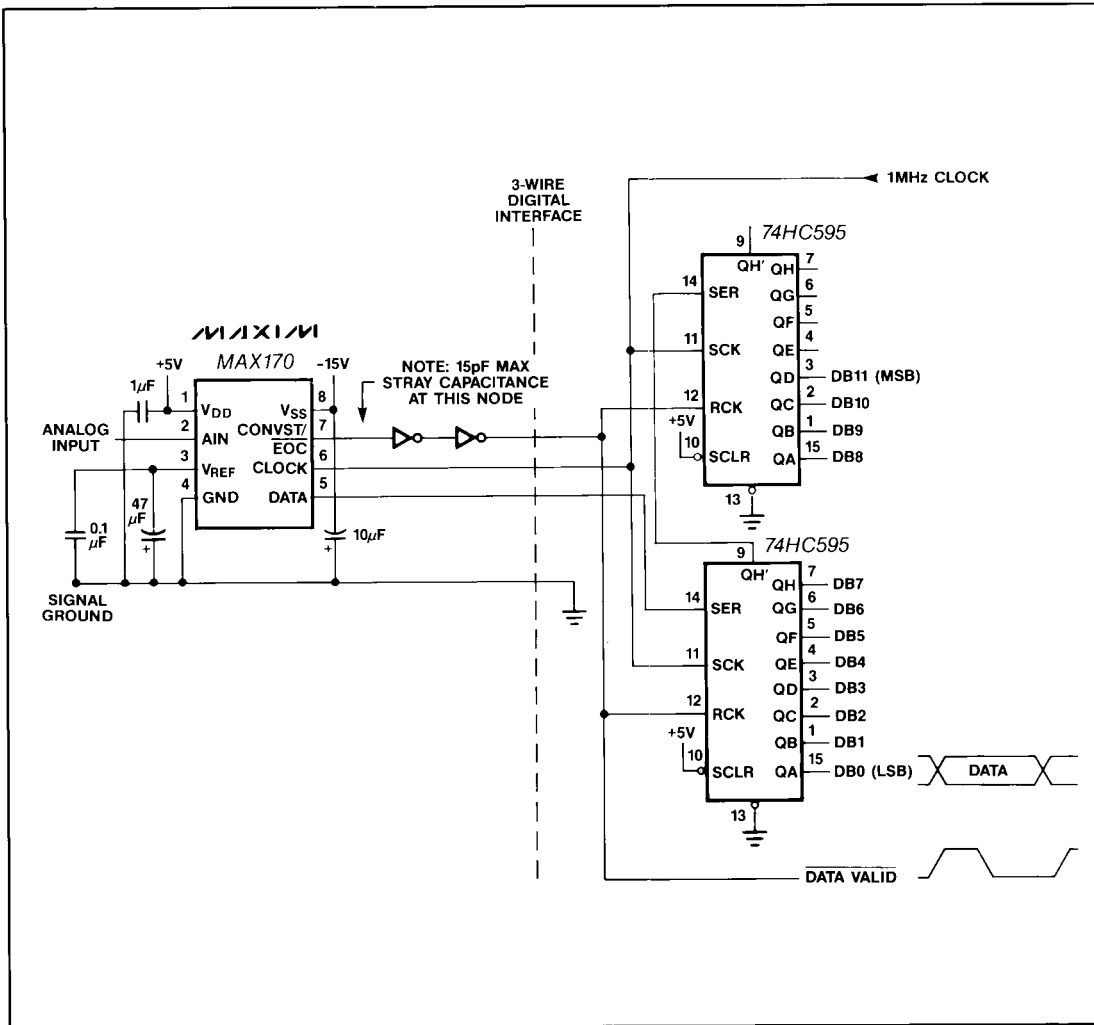

Figure 15. Self-Start Mode

Application Hints

Physical Layout

For best system performance printed circuit boards should be used for the MAX170. Wire wrap boards are not recommended. The layout of the board should ensure that digital and analog signal lines are kept separated from each other as much as possible. Care should be taken not to run analog and digital lines parallel to each other or digital lines underneath the MAX170 package.

Grounding

Figure 17 shows the recommended system ground connections. A single point analog STAR ground should be established at pin 4 (GND) of the MAX170. All grounds should be connected to this STAR ground. The ground return to the power supply from this STAR ground should be low impedance for noise-free operation of the MAX170.

Serial Output 5.6 μ s 12-Bit A/D Converter

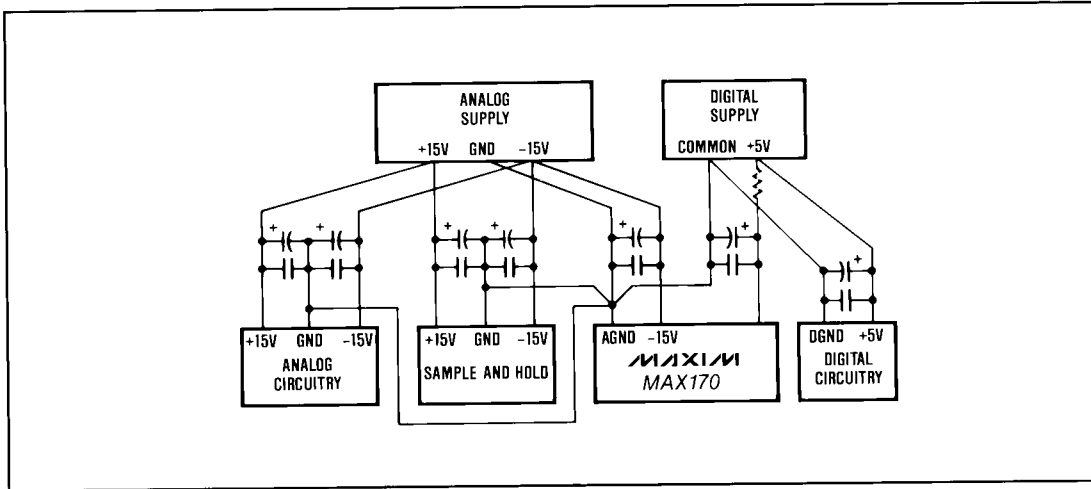

Figure 17. Power Supply Grounding

Power Supply Bypassing

The high speed comparator in the MAX170 is sensitive to high frequency noise in the V_{DD} and V_{SS} power supplies. These supplies should be by-passed to the analog STAR ground with 0.1 μ F and 10 μ F by-pass capacitors with minimum lead length for supply noise rejection. If the +5V power supply is very noisy, a small resistor (10-20 Ω) can be connected as shown in Figure 17 to filter external noise.

Internal Reference

The MAX170 has an on-chip reference that is built with a buffered and temperature compensated buried zener diode, laser-trimmed to -5.25V \pm 1%. Its output is connected to the V_{REF} pin and also drives the internal DAC. This output can be used as a reference voltage source for other components.

For minimal transition noise, the V_{REF} pin must be decoupled with a 47 μ F tantalum capacitor in parallel with a 0.1 μ F capacitor to filter out the wideband noise of the zener diode and to provide low impedance at high frequencies (Figure 1). This capacitor also creates the dominant pole of the reference buffer amplifier for stability. If this capacitor is not used, the reference will oscillate. Since the MAX170 buffer amplifier is designed to be stable with this capacitor, no series resistance should be used between the V_{REF} pin and the capacitor. This capacitor must not be less than 4.7 μ F.

Driving the Analog Input

The input signal leads to AIN and GND should be as short as possible to minimize noise pick-up. If the leads must be long, use shielded cables to minimize noise pick-up.

The input impedance at the AIN pin is typically 2.5k Ω . The amplifier driving AIN must have low enough DC output impedance for low gain error. Furthermore, low AC output impedance is also required since the analog input current is modulated at the clock rate during a conversion. The output impedance of the driving amplifier is reduced by the loop gain at the frequency of interest. With a maximum clock rate of 2.5MHz, it is possible to drive the MAX170 with amplifiers like the OP-42, AD711, or OP-27. At 1MHz clock rate a MAX400 or OP-07 can also be used.

Chip Topography

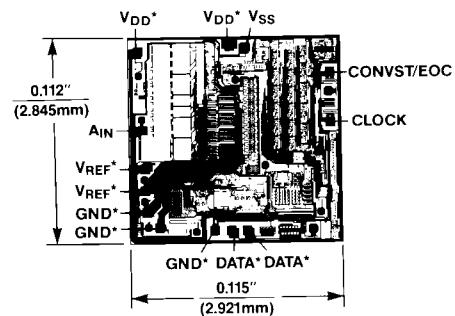

* Pads with the same name must be bonded together.

Maxim cannot assume responsibility for use of any circuitry other than circuitry entirely embodied in a Maxim product. No circuit patent licenses are implied. Maxim reserves the right to change the circuitry and specifications without notice at any time.

12 Maxim Integrated Products, 120 San Gabriel Drive, Sunnyvale, CA 94086 (408) 737-7600

©1989 Maxim Integrated Products Printed USA

MAXIM is a registered trademark of Maxim Integrated Products.



[WHAT'S NEW](#)
[PRODUCTS](#)
[SOLUTIONS](#)
[DESIGN](#)
[APPNOTES](#)
[SUPPORT](#)
[BUY](#)
[COMPANY](#)
[MEMBERS](#)

MAX170

Part Number Table

Notes:

1. See the [MAX170 QuickView Data Sheet](#) for further information on this product family or download the [MAX170 full data sheet](#) (PDF, 464kB).
2. Other options and links for purchasing parts are listed at: <http://www.maxim-ic.com/sales>.
3. [Didn't Find What You Need?](#) Ask our applications engineers. Expert assistance in finding parts, usually within one business day.
4. Part number suffixes: T or T&R = tape and reel; + = RoHS/lead-free; # = RoHS/lead-exempt. More: See [full data sheet](#) or [Part Naming Conventions](#).
5. * Some packages have variations, listed on the drawing. "PkgCode/Variation" tells which variation the product uses.

Part Number	Free Sample	Buy Direct	Package: TYPE PINS SIZE DRAWING CODE/VAR *	Temp	RoHS/Lead-Free? Materials Analysis
MAX170BCPA+	<input type="checkbox"/>	<input type="checkbox"/>		0C to +70C	RoHS/Lead-Free: Yes
MAX170DMJA	<input type="checkbox"/>	<input type="checkbox"/>	Ceramic DIP;8 pin;.300" Dwg: 21-0045A (PDF) Use pkgcode/variation: J8-2*	-55C to +125C	RoHS/Lead-Free: No Materials Analysis
MAX170DMJA/883B	<input type="checkbox"/>	<input type="checkbox"/>	Ceramic DIP;8 pin;.300" Dwg: 21-0045A (PDF) Use pkgcode/variation: J8-2*	-55C to +125C	RoHS/Lead-Free: No Materials Analysis
MAX170CMJA	<input type="checkbox"/>	<input type="checkbox"/>	Ceramic DIP;8 pin;.300" Dwg: 21-0045A (PDF) Use pkgcode/variation: J8-2*	-55C to +125C	RoHS/Lead-Free: No Materials Analysis
MAX170DC/D	<input type="checkbox"/>	<input type="checkbox"/>			RoHS/Lead-Free: No
MAX170ACPA+	<input type="checkbox"/>	<input type="checkbox"/>		0C to +70C	RoHS/Lead-Free: Yes
MAX170CCPA+	<input type="checkbox"/>	<input type="checkbox"/>	PDIP;8 pin;.300" Dwg: 21-0043D (PDF) Use pkgcode/variation: P8+3*	0C to +70C	RoHS/Lead-Free: Yes Materials Analysis

MAX170DCPA+			PDIP;8 pin;.300" Dwg: 21-0043D (PDF) Use pkgcode/variation: P8+3*	0C to +70C	RoHS/Lead-Free: Yes Materials Analysis
MAX170ACPA				0C to +70C	RoHS/Lead-Free: No
MAX170DCPA			PDIP;8 pin;.300" Dwg: 21-0043D (PDF) Use pkgcode/variation: P8-3*	0C to +70C	RoHS/Lead-Free: No Materials Analysis
MAX170CCPA			PDIP;8 pin;.300" Dwg: 21-0043D (PDF) Use pkgcode/variation: P8-3*	0C to +70C	RoHS/Lead-Free: No Materials Analysis
MAX170BCPA				0C to +70C	RoHS/Lead-Free: No
MAX170CEPA+			PDIP;8 pin;.300" Dwg: 21-0043D (PDF) Use pkgcode/variation: P8+3*	-40C to +85C	RoHS/Lead-Free: Yes Materials Analysis
MAX170DEPA+			PDIP;8 pin;.300" Dwg: 21-0043D (PDF) Use pkgcode/variation: P8+3*	-40C to +85C	RoHS/Lead-Free: Yes Materials Analysis
MAX170DEPA			PDIP;8 pin;.300" Dwg: 21-0043D (PDF) Use pkgcode/variation: P8-3*	-40C to +85C	RoHS/Lead-Free: No Materials Analysis
MAX170CEPA			PDIP;8 pin;.300" Dwg: 21-0043D (PDF) Use pkgcode/variation: P8-3*	-40C to +85C	RoHS/Lead-Free: No Materials Analysis
MAX170CCWE+T			SOIC;16 pin;.300" Dwg: 21-0042B (PDF) Use pkgcode/variation: W16+2*	0C to +70C	RoHS/Lead-Free: Yes Materials Analysis
MAX170ACWE-T				0C to +70C	RoHS/Lead-Free: No
MAX170CCWE+			SOIC;16 pin;.300" Dwg: 21-0042B (PDF) Use pkgcode/variation: W16+2*	0C to +70C	RoHS/Lead-Free: Yes Materials Analysis
MAX170ACWE+			SOIC;16 pin;.300" Dwg: 21-0042B (PDF) Use pkgcode/variation: W16+2*	0C to +70C	RoHS/Lead-Free: Yes Materials Analysis
MAX170DCWE+			SOIC;16 pin;.300" Dwg: 21-0042B (PDF) Use pkgcode/variation: W16+2*	0C to +70C	RoHS/Lead-Free: Yes Materials Analysis
MAX170DCWE+T			SOIC;16 pin;.300" Dwg: 21-0042B (PDF) Use pkgcode/variation: W16+2*	0C to +70C	RoHS/Lead-Free: Yes Materials Analysis
MAX170CCWE			SOIC;16 pin;.300" Dwg: 21-0042B (PDF) Use pkgcode/variation: W16-2*	0C to +70C	RoHS/Lead-Free: No Materials Analysis

MAX170CCWE-T			SOIC;16 pin;.300" Dwg: 21-0042B (PDF) Use pkgcode/variation: W16-2*	0C to +70C	RoHS/Lead-Free: No Materials Analysis
MAX170ACWE			SOIC;16 pin;.300" Dwg: 21-0042B (PDF) Use pkgcode/variation: W16-2*	0C to +70C	RoHS/Lead-Free: No Materials Analysis
MAX170DCWE-T			SOIC;16 pin;.300" Dwg: 21-0042B (PDF) Use pkgcode/variation: W16-2*	0C to +70C	RoHS/Lead-Free: No Materials Analysis
MAX170DCWE			SOIC;16 pin;.300" Dwg: 21-0042B (PDF) Use pkgcode/variation: W16-2*	0C to +70C	RoHS/Lead-Free: No Materials Analysis
MAX170ACWE+T				0C to +70C	RoHS/Lead-Free: Yes
MAX170DEWE+			SOIC;16 pin;.300" Dwg: 21-0042B (PDF) Use pkgcode/variation: W16+2*	-40C to +85C	RoHS/Lead-Free: Yes Materials Analysis
MAX170CEWE+T				-40C to +85C	RoHS/Lead-Free: Yes
MAX170CEWE+			SOIC;16 pin;.300" Dwg: 21-0042B (PDF) Use pkgcode/variation: W16+2*	-40C to +85C	RoHS/Lead-Free: Yes Materials Analysis
MAX170CEWE-T				-40C to +85C	RoHS/Lead-Free: No
MAX170DEWE-T				-40C to +85C	RoHS/Lead-Free: No
MAX170DEWE			SOIC;16 pin;.300" Dwg: 21-0042B (PDF) Use pkgcode/variation: W16-2*	-40C to +85C	RoHS/Lead-Free: No Materials Analysis
MAX170CEWE			SOIC;16 pin;.300" Dwg: 21-0042B (PDF) Use pkgcode/variation: W16-2*	-40C to +85C	RoHS/Lead-Free: No Materials Analysis
MAX170DEWE+T				-40C to +85C	RoHS/Lead-Free: Yes

[Didn't Find What You Need?](#)

[CONTACT US: SEND US AN EMAIL](#)