

# Standard Type Mini-molded chip LEDs

## SML-310 Series

Package Size (mm)	Pure Green	Green	Yellow	Orange	Red	
	GaP			GaAsP on Gap		GaAlAs on GaAs
	555nm	570nm	585nm	610nm	650nm	660nm
1608 (0603) 1.6x0.8 t=0.8						
	SML-310PT	SML-310MT	SML-310YT	SML-310DT	SML-310VT	SML-310LT

### Absolute Maximum Ratings (Ta=25°C)

Part No.	Emitting color	Power dissipation Pd (mW)	Forward current IF (mA)	Peak forward current * IFP (mA)	Reverse voltage VR (V)	Operating temperature Topr (°C)	Storage temperature Tstg (°C)
SML-310PT	Pure Green	55	20	60	4	-30 to +85	-40 to +85
SML-310MT	Green						
SML-310YT	Yellow						
SML-310DT	Orange	60	25	75			
SML-310VT	Red						
SML-310LT	Red						

\* IFP measured under duty ≤ 1/5, pulse width ≤ 1ms.

### External Dimensions (Unit : mm)

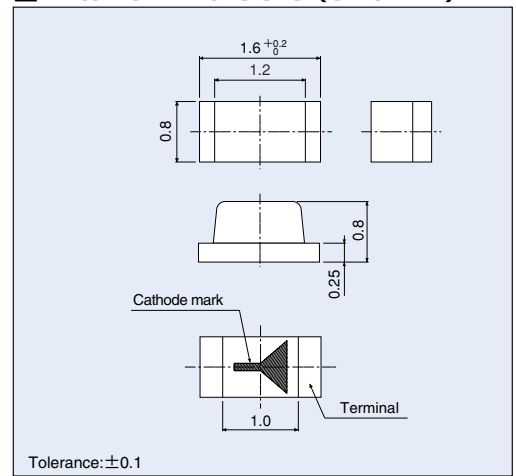

### Electrical Optical Characteristics (Ta=25°C)

Part No.	Resin Color	Forward voltage VF		Reverse current IR		Light wavelength			Brightness Iv		
		Typ. (V)	IF (mA)	Max. (μA)	VR (V)	Peak λp (nm)	Half-wave Δλ (nm)	IF (mA)	Min. (mcd)	Typ. (mcd)	IF (mA)
SML-310PT	Transparent	2.2	20	100	4	555	40	20	1.4	4	20
SML-310MT						570			3.6	16	
SML-310YT						585			2.2	6.3	
SML-310DT		Clear	2.0				610	1.4	4		
SML-310VT				650	3.6	16					
SML-310LT				1.75			660	25			

### Directivity

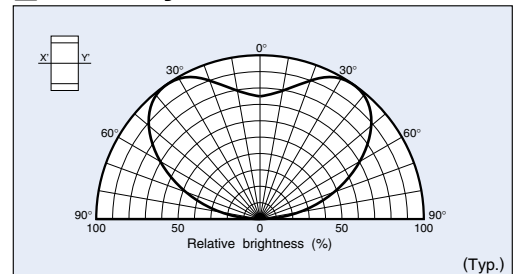

### Recommended Pad Layout

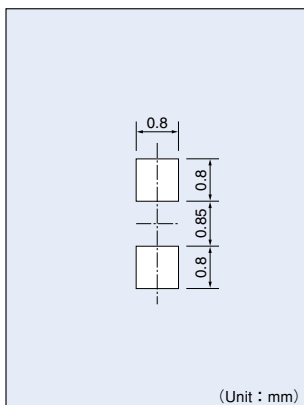

(Unit : mm)

The recommended thickness of the screen mask for soldering is between 100 and 200 μm. The hole size of the screen mask should be same as the recommended land pattern or smaller.

### Packaging Specifications (Unit : mm)

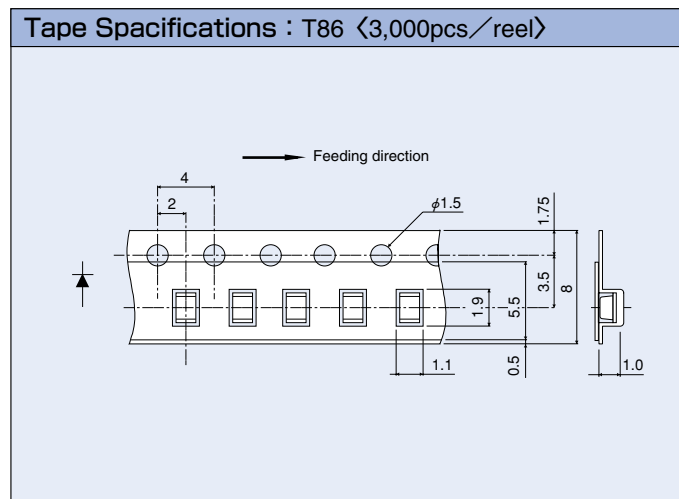

### Reel Specifications

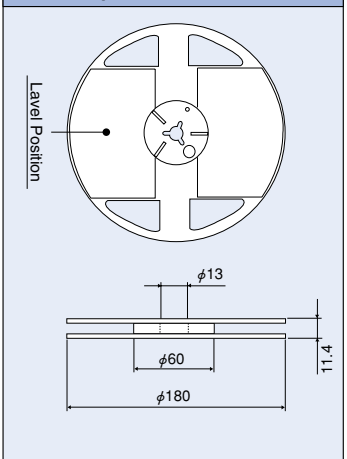

## Electrical Characteristic Curves

### Forward Current - Forward Voltage

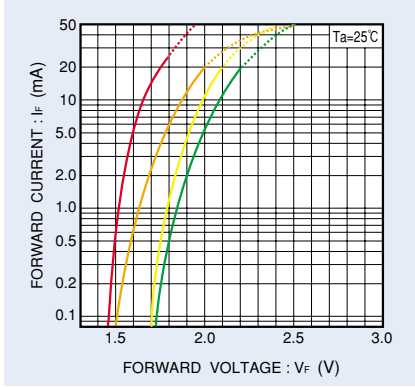

### Relative Luminous Intensity - Case Temperature

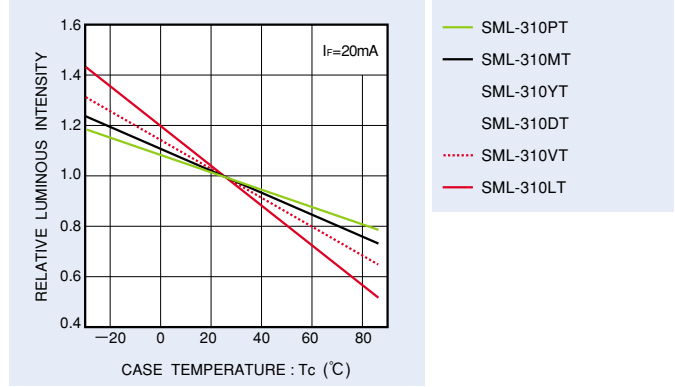

### Relative Luminous Intensity - Forward Current

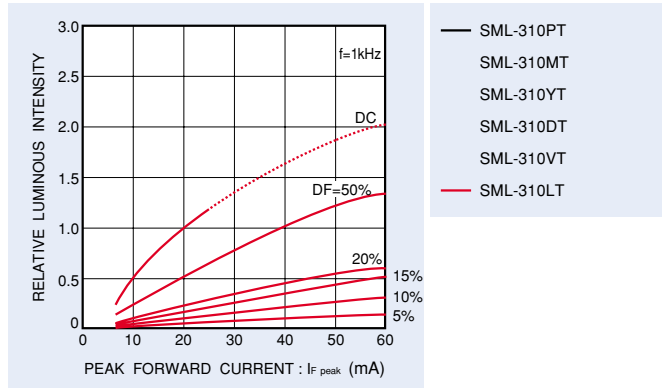
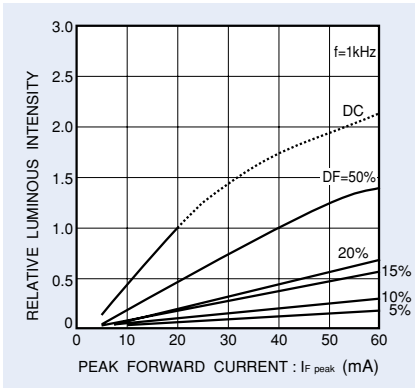

### Ratio of Maximum Tolerable Peak Current - Pulse Duration

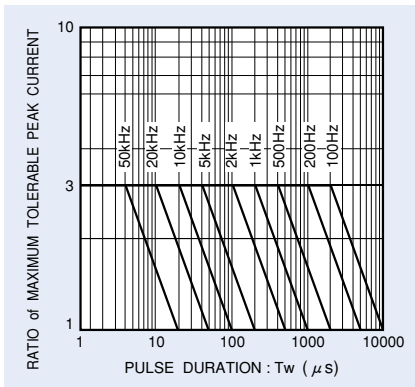

### Derating

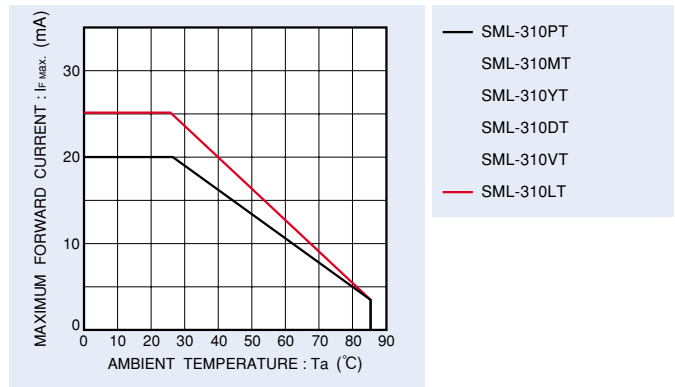

# Standard Type Mini-molded chip LEDs

## SML-510 Series

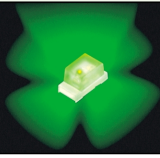
Package Size (mm)	Green
	GaP
	570nm
1608 (0603) 1.6×0.8 t=0.55	
SML-510MW	

### Absolute Maximum Ratings (Ta=25°C)

Part No.	Emitting color	Power dissipation P <sub>D</sub> (mW)	Forward current I <sub>F</sub> (mA)	Peak forward current * I <sub>FP</sub> (mA)	Reverse voltage V <sub>R</sub> (V)	Operating temperature T <sub>opr</sub> (°C)	Storage temperature T <sub>stg</sub> (°C)
SML-510MW	Green	55	20	60	4	-30 to +85	-40 to +85

\* I<sub>FP</sub> measured under duty ≤ 1/5, pulse width ≤ 1ms.

### Electrical Optical Characteristics (Ta=25°C)

Part No.	Resin Color	Forward voltage V <sub>F</sub>		Reverse current I <sub>R</sub>		Light wavelength			Brightness I <sub>v</sub>		
		Typ. (V)	I <sub>F</sub> (mA)	Max. (μA)	V <sub>R</sub> (V)	Peak λ <sub>p</sub> (nm)	Half-wave Δλ (nm)	I <sub>F</sub> (mA)	Min. (mcd)	Typ. (mcd)	I <sub>F</sub> (mA)
SML-510MW	Milky White	2.2	20	100	4	570	40	20	3.6	16	20

### External Dimensions (Unit : mm)

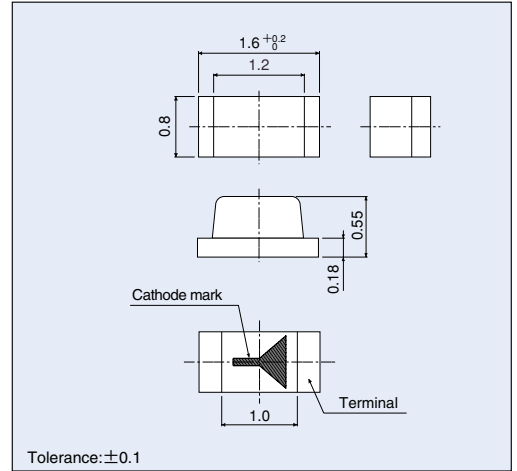

### Directivity

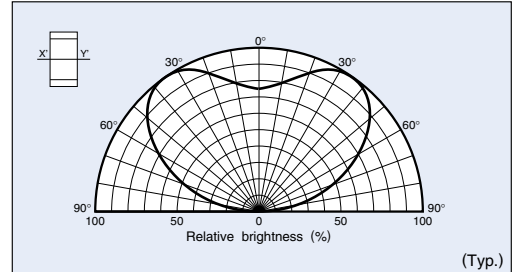

### Recommended Pad Layout

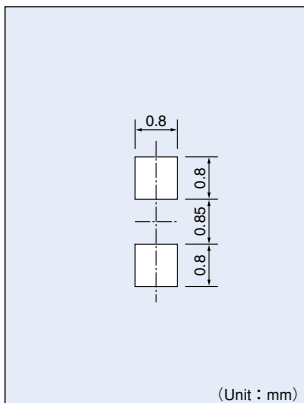

The recommended thickness of the screen mask for soldering is between 100 and 200 μm. The hole size of the screen mask should be the same as the recommended land pattern or smaller.

### Packaging Specifications (Unit : mm)

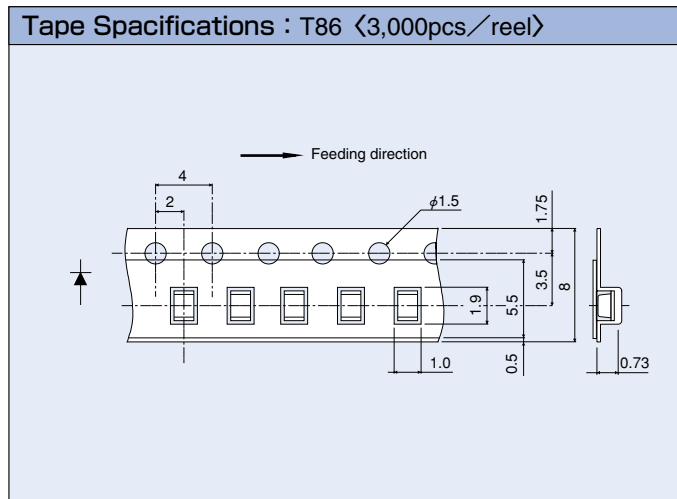

### Reel Specifications

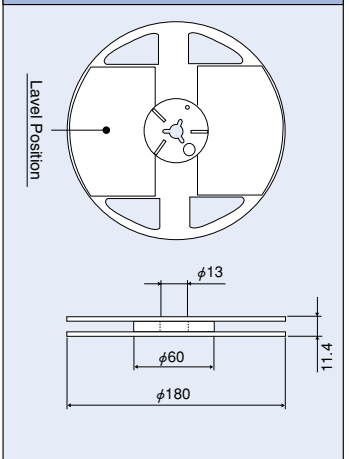

## Electrical Characteristic Curves

### Forward Current - Forward Voltage

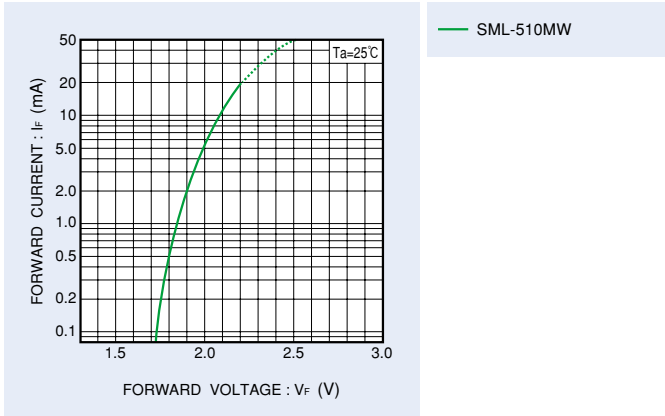

### Relative Luminous Intensity - Case Temperature

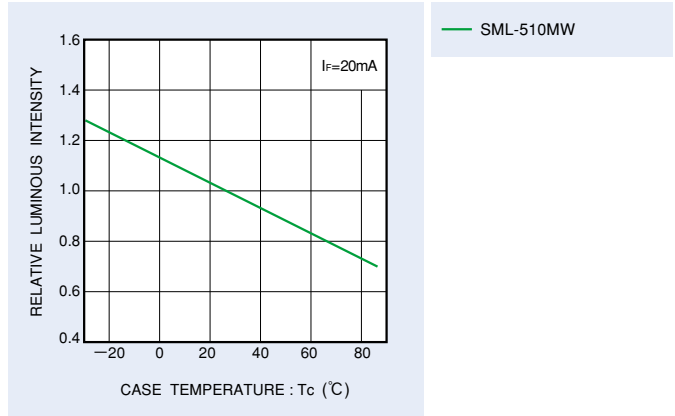

### Relative Luminous Intensity - Forward Current

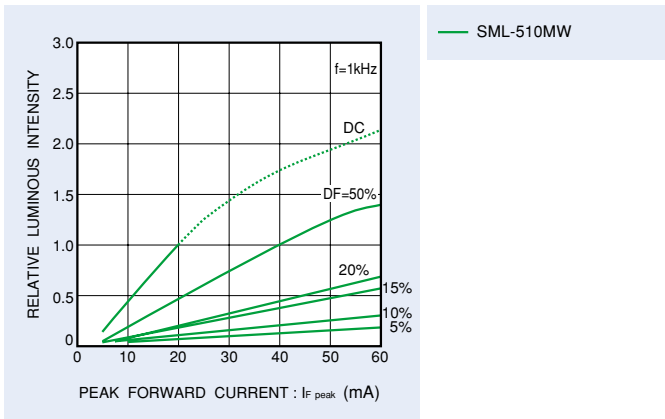

### Ratio of Maximum Tolerable Peak Current - Pulse Duration

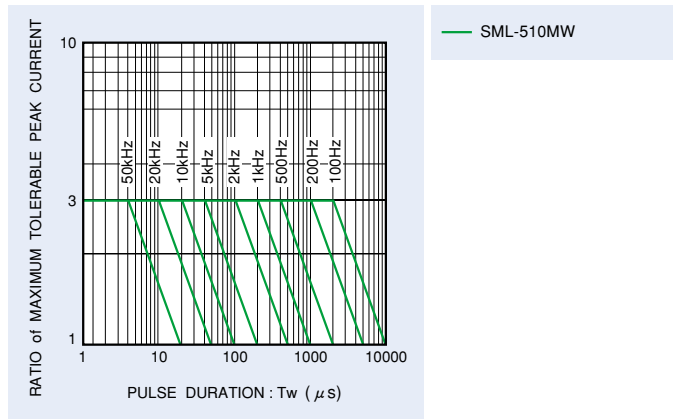

## Derating

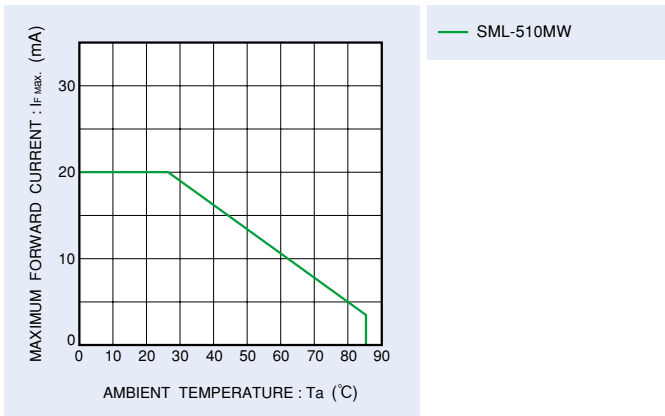

# Standard Type Mini-molded chip LEDs

## SML-410 Series

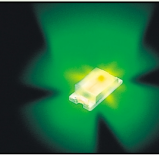
Package Size (mm)	Green
	GaP
	570nm
1608 (0603) 1.6x0.8 t=0.4	
SML-410MW	

### Absolute Maximum Ratings (Ta=25°C)

Part No.	Emitting color	Power dissipation P <sub>D</sub> (mW)	Forward current I <sub>F</sub> (mA)	Peak forward current * I <sub>FP</sub> (mA)	Reverse voltage V <sub>R</sub> (V)	Operating temperature T <sub>opr</sub> (°C)	Storage temperature T <sub>stg</sub> (°C)
SML-410MW	Green	65	25	60	4	-30 to +85	-40 to +85

\* I<sub>FP</sub> measured under duty ≤ 1/5, pulse width ≤ 1ms.

### Electrical Optical Characteristics (Ta=25°C)

Part No.	Resin Color	Forward voltage V <sub>F</sub>		Reverse current I <sub>R</sub>		Light wavelength			Brightness I <sub>v</sub>		
		Typ. (V)	I <sub>F</sub> (mA)	Max. (μA)	V <sub>R</sub> (V)	Peak λ <sub>p</sub> (nm)	Half-wave Δλ (nm)	I <sub>F</sub> (mA)	Min. (mcd)	Typ. (mcd)	I <sub>F</sub> (mA)
SML-410MW	Milky White	2.2	20	100	4	570	40	20	3.6	16	20

### External Dimensions (Unit : mm)

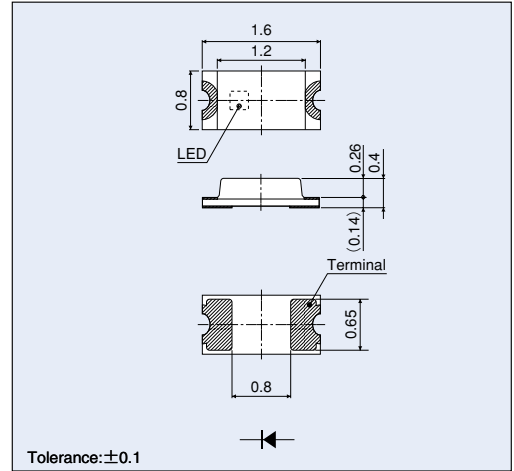

### Directivity

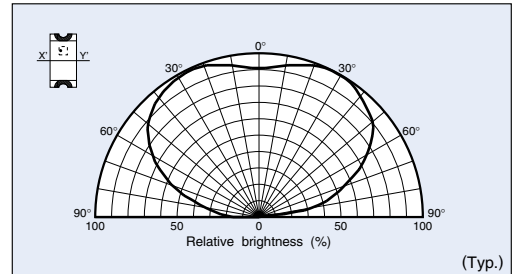

### Recommended Pad Layout

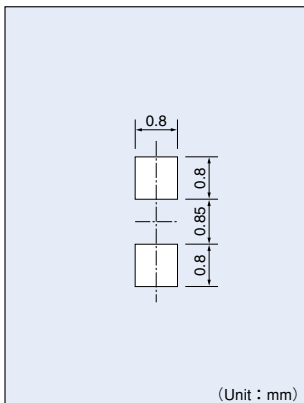

The recommended thickness of the screen mask for soldering is between 100 and 200 μm. The hole size of the screen mask should be the same as the recommended land pattern or smaller.

### Packaging Specifications (Unit : mm)

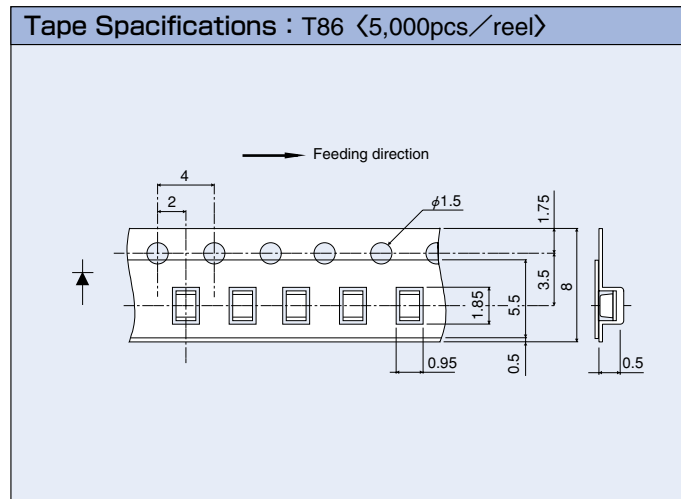

### Reel Specifications

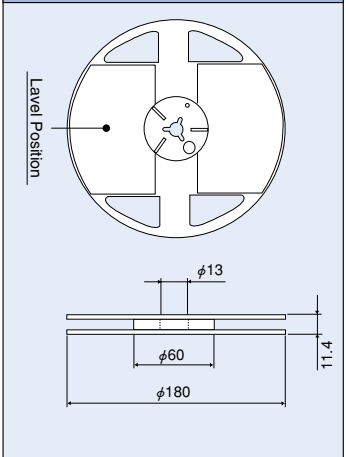

## Electrical Characteristic Curves

### Forward Current - Forward Voltage

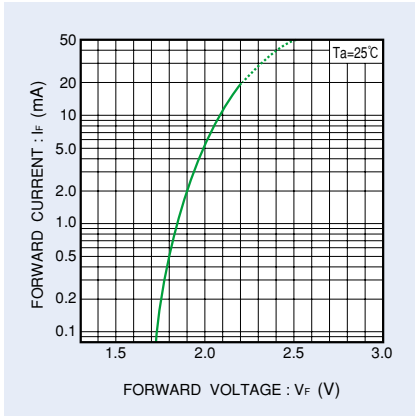

SML-410MW

### Relative Luminous Intensity - Case Temperature

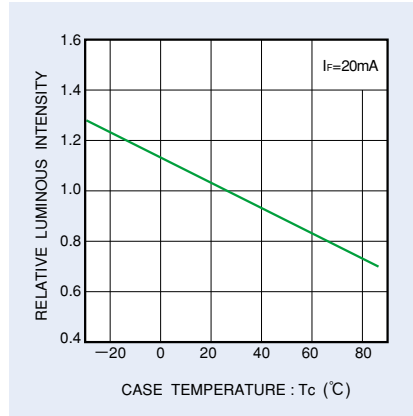

SML-410MW

### Relative Luminous Intensity - Forward Current

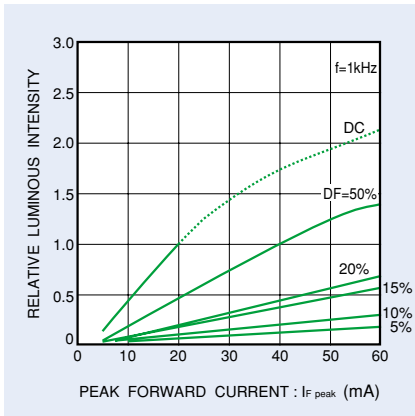

SML-410MW

### Ratio of Maximum Tolerable Peak Current - Pulse Duration

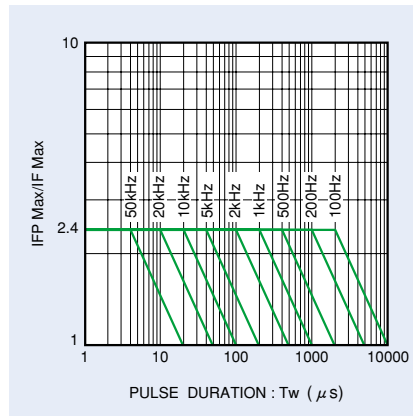

SML-410MW

## Derating

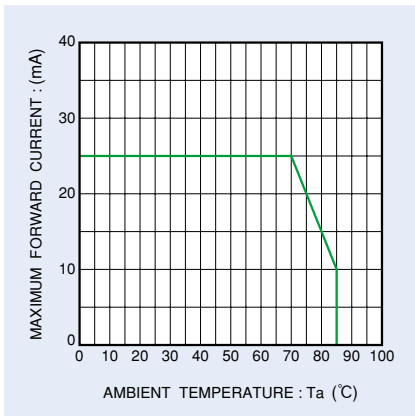

SML-410MW

# Standard Type Mini-molded chip LEDs

## SML-210 Series

Package Size (mm)	Pure Green	Green	Yellow	Orange	Red	
	GaP			GaAsP on GaP		GaAlAs on GaAs
	555nm	570nm	585nm	610nm	650nm	660nm
2012 (0805) 2.0x1.25 t=0.8						
	SML-210PT	SML-210MT	SML-210YT	SML-210DT	SML-210VT	SML-210LT

### Absolute Maximum Ratings (Ta=25°C)

Part No.	Emitting color	Power dissipation Pd (mW)	Forward current IF (mA)	Peak forward current * IFP (mA)	Reverse voltage VR (V)	Operating temperature Topr (°C)	Storage temperature Tstg (°C)
SML-210PT	Pure Green	70	25	60	4	-30 to +85	-40 to +85
SML-210MT	Green						
SML-210YT	Yellow						
SML-210DT	Orange						
SML-210VT	Red						
SML-210LT	Red	75	30	75			

\* IFP measured under duty ≤ 1/5, pulse width ≤ 1ms.

### External Dimensions (Unit : mm)

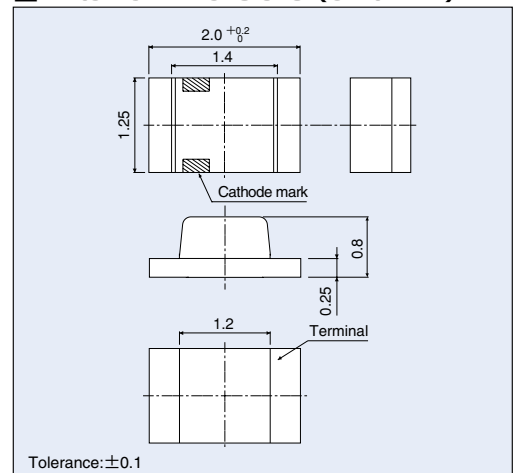

### Electrical Optical Characteristics (Ta=25°C)

Part No.	Resin Color	Forward voltage VF		Reverse current IR		Light wavelength			Brightness Iv		
		Typ. (V)	IF (mA)	Max. (μA)	VR (V)	Peak λp (nm)	Half-wave Δλ (nm)	IF (mA)	Min. (mcd)	Typ. (mcd)	IF (mA)
SML-210PT	Transparent	2.2	20	100	4	555	40	20	1.4	4	20
SML-210MT						570			3.6	16	
SML-210YT		2.1				585			2.2	6.3	
SML-210DT		2.0				610			1.4	4	
SML-210VT		1.75				650			3.6	10	
SML-210LT						660			25		

### Directivity

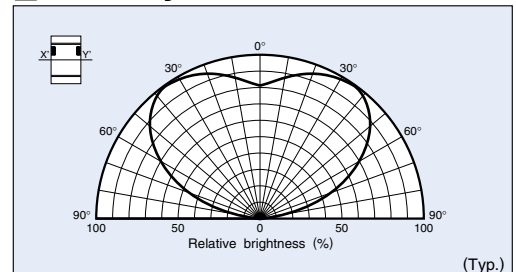

### Recommended Pad Layout

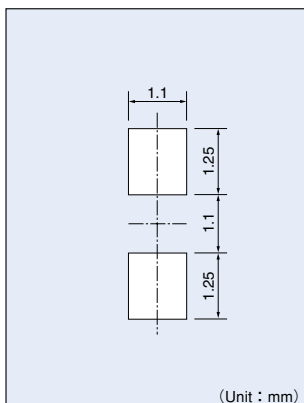

The recommended thickness of the screen mask for soldering is between 100 and 200 μm. The hole size of the screen mask should be same as the recommended land pattern or smaller.

### Packaging Specifications (Unit : mm)

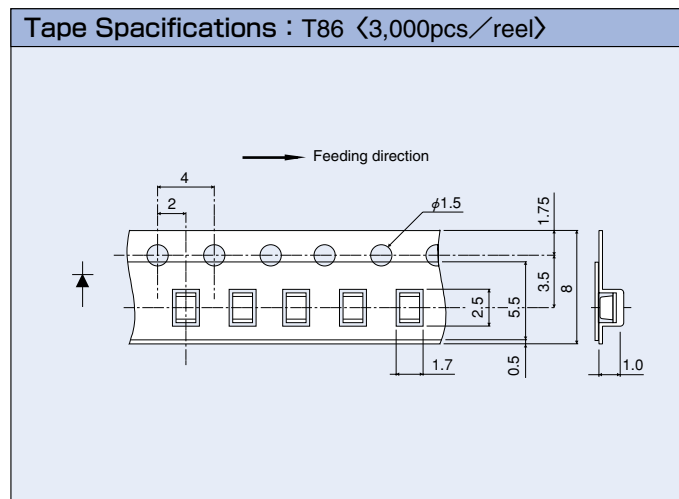

### Reel Specifications

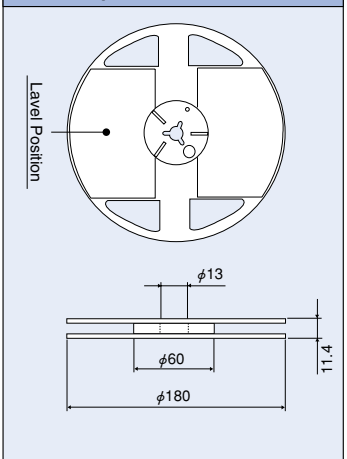

## Electrical Characteristic Curves

### Forward Current - Forward Voltage

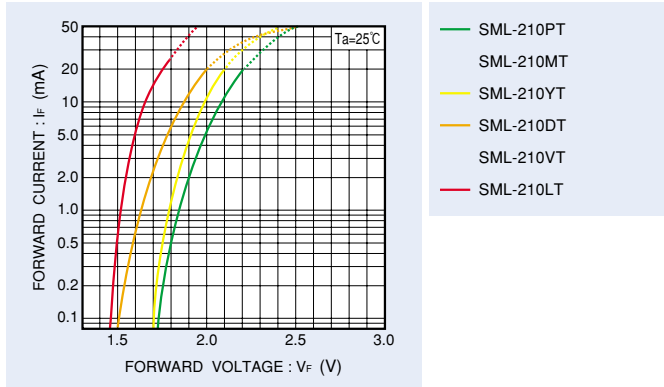

### Relative Luminous Intensity - Case Temperature

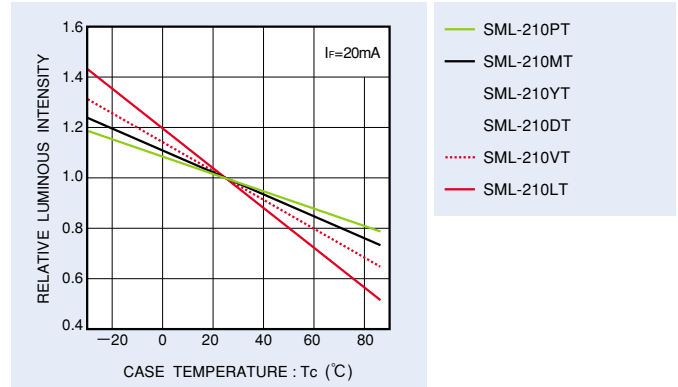

### Relative Luminous Intensity - Forward Current

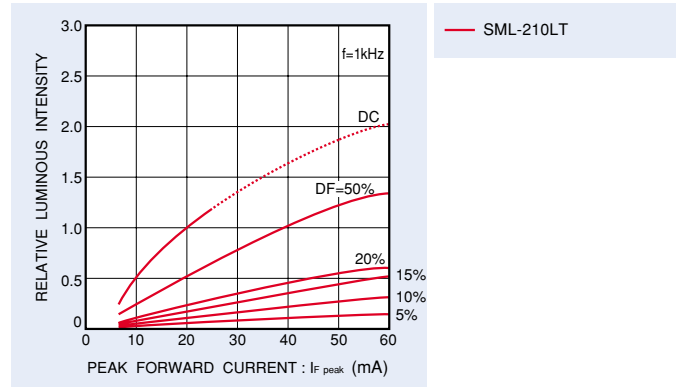
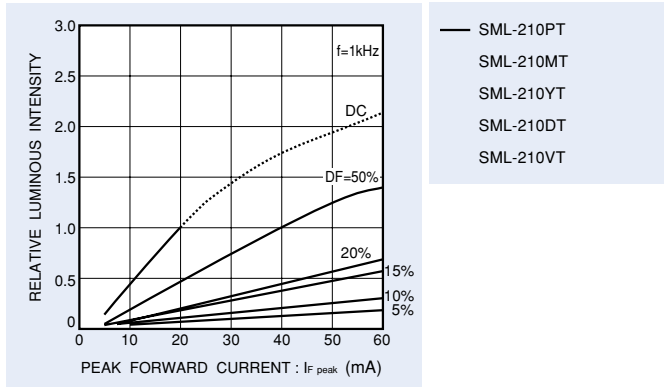

### Ratio of Maximum Tolerable Peak Current - Pulse Duration

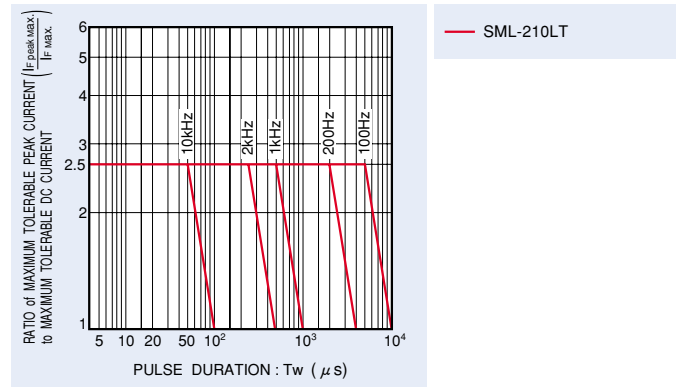
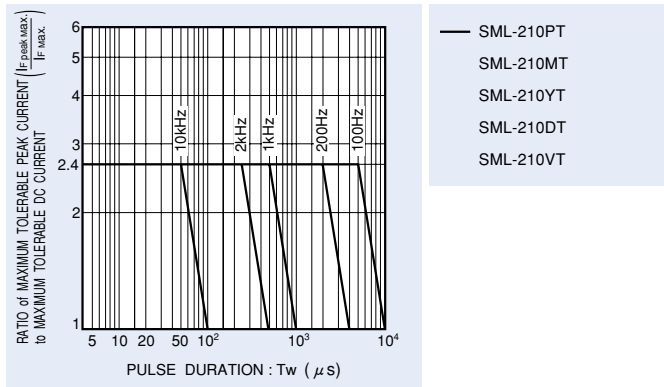

### Derating

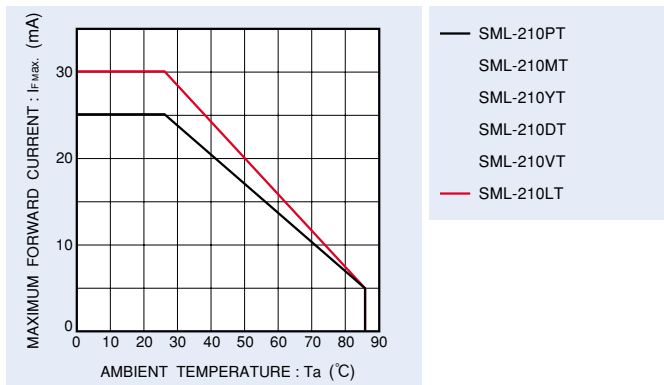

# Standard Type Chip LEDs with reflector

## SML-010 Series

Package Size (mm)	Pure Green	Green	Yellow	Orange	Red	
	GaP		GaAsP on GaP		GaAlAs on GaAs	
	555nm	570nm	585nm	610nm	650nm	660nm
3216 (1206) 3.0x2.0 t=1.3						
	SML-010PT	SML-010MT	SML-010YT	SML-010DT	SML-010VT	SML-010LT

### Absolute Maximum Ratings (Ta=25°C)

Part No.	Emitting color	Power dissipation Pd (mW)	Forward current IF (mA)	Peak forward current * I <sub>FP</sub> (mA)	Reverse voltage VR (V)	Operating temperature T <sub>opr</sub> (°C)	Storage temperature T <sub>stg</sub> (°C)
SML-010PT	Pure Green	70	25	60	4	-30 to +85	-40 to +85
SML-010MT	Green						
SML-010YT	Yellow						
SML-010DT	Orange						
SML-010VT	Red						
SML-010LT	Red	75	30	75			

\* I<sub>FP</sub> measured under duty ≤ 1/5, pulse width ≤ 1ms.

### External Dimensions (Unit : mm)

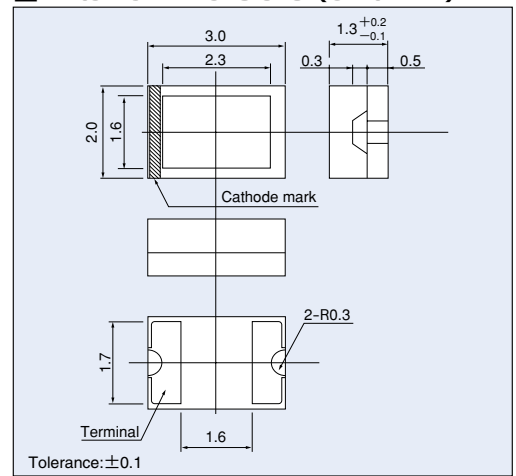

### Electrical Optical Characteristics (Ta=25°C)

Part No.	Resin Color	Forward voltage VF		Reverse current IR		Light wavelength			Brightness Iv		
		Typ. (V)	IF (mA)	Max. (μA)	VR (V)	Peak λp (nm)	Half-wave Δλ (nm)	IF (mA)	Min. (mcd)	Typ. (mcd)	IF (mA)
SML-010PT	Transparent Clear	2.2	20	100	4	555	40	20	2.2	6.3	20
SML-010MT						570				5.6	
SML-010YT		2.1			585		2.2	6.3			
SML-010DT		2.0			610		3.6	10			
SML-010VT					650		2.2	6.3			
SML-010LT		1.75			660	25	5.6	16			

### Directivity

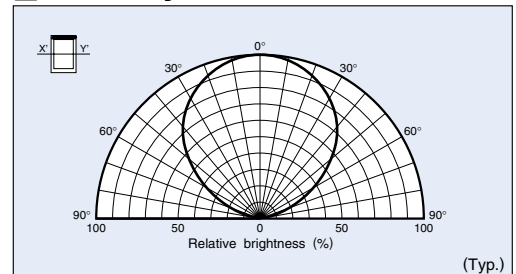

### Recommended Pad Layout

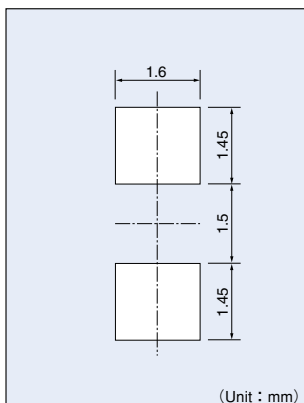

The recommended thickness of the screen mask for soldering is between 100 and 200μm. The hole size of the screen mask should be the same as the recommended land pattern or smaller.

### Packaging Specifications (Unit : mm)

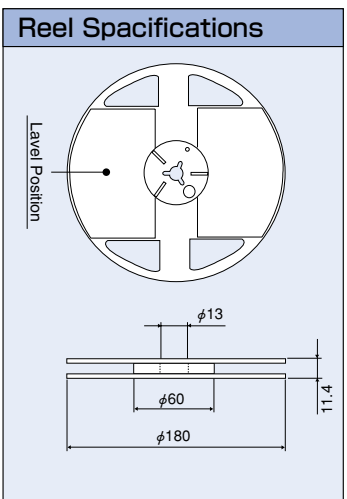
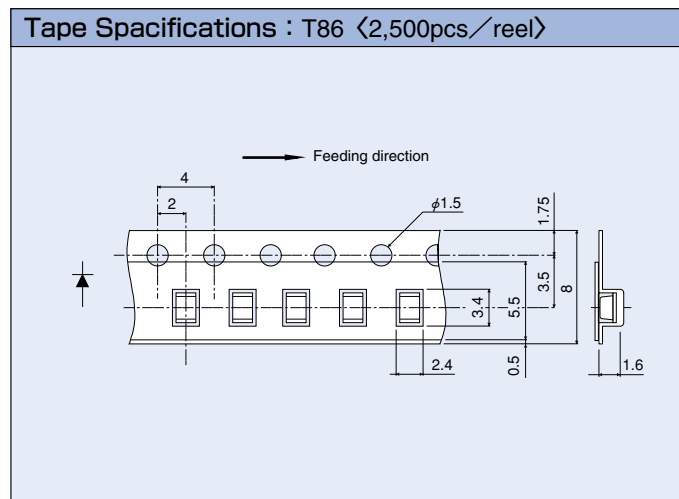

## Electrical Characteristic Curves

### Forward Current - Forward Voltage

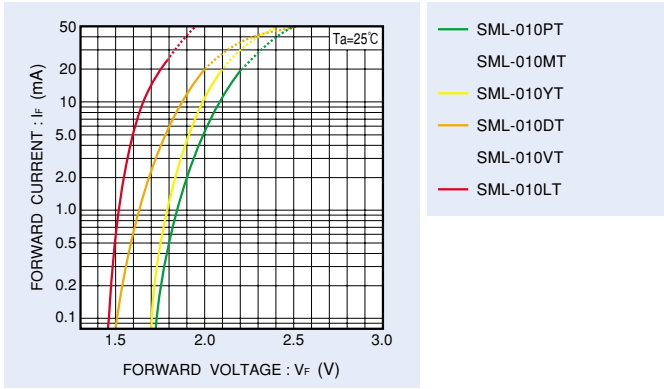

### Relative Luminous Intensity - Case Temperature

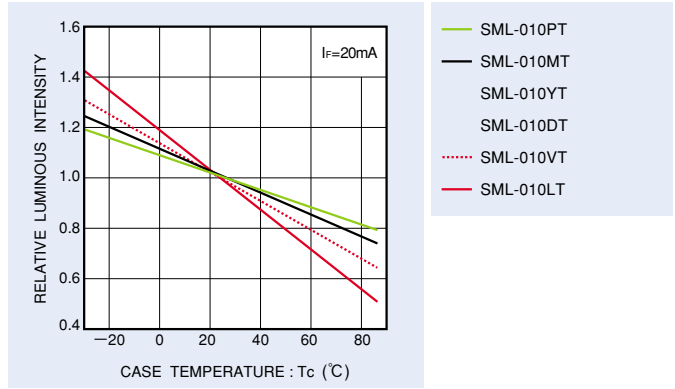

### Relative Luminous Intensity - Forward Current

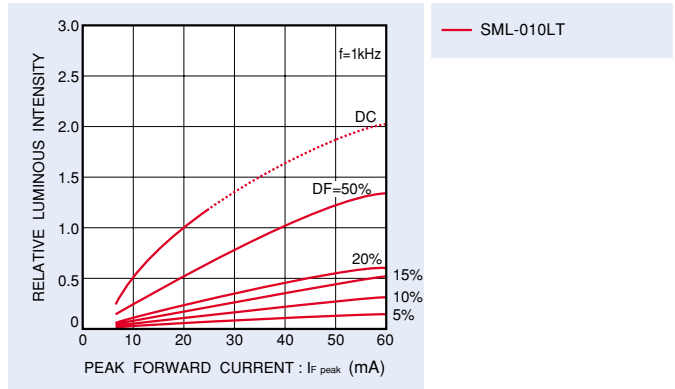
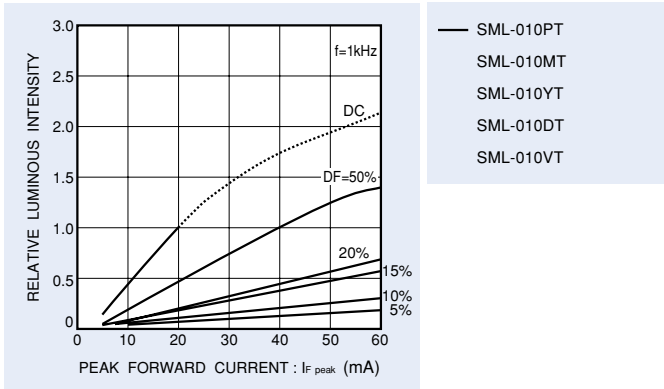

### Ratio of Maximum Tolerable Peak Current - Pulse Duration

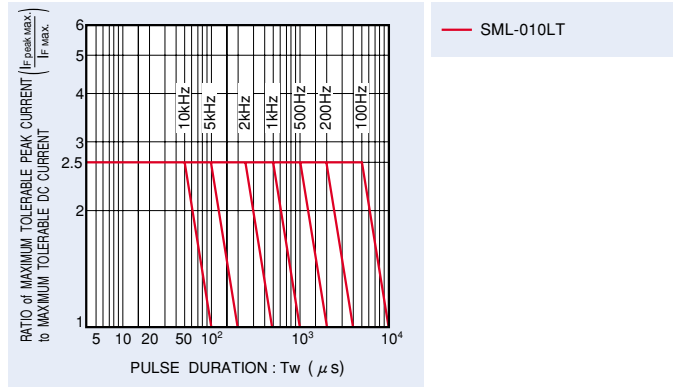
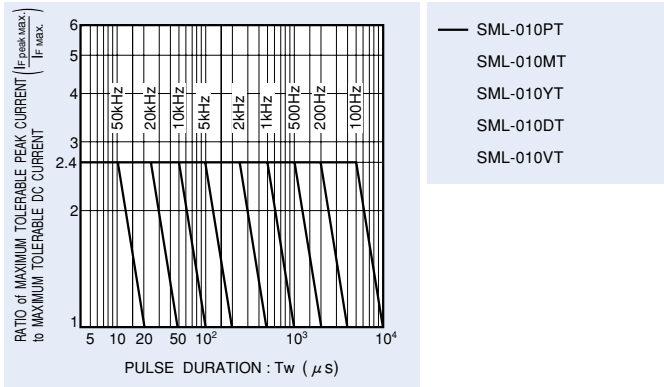

### Derating

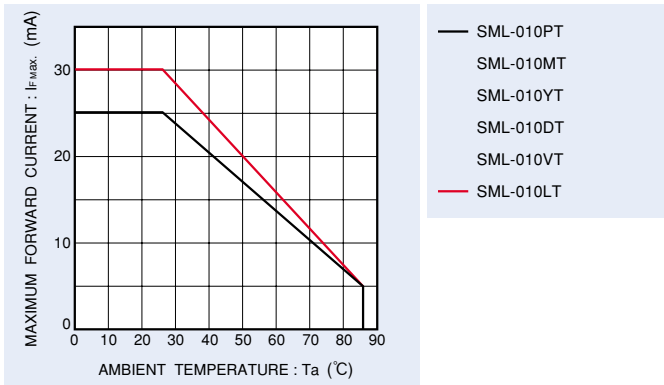

# Standard Type Side view chip LEDs

## SML-A10 Series

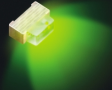
Package Size (mm)	Green
	GaP
	570nm
1611 (0605) 1.6×1.15 t=0.55	
SML-A10MT	

### Absolute Maximum Ratings (Ta=25°C)

Part No.	Emitting color	Power dissipation P <sub>D</sub> (mW)	Forward current I <sub>F</sub> (mA)	Peak forward current * I <sub>FP</sub> (mA)	Reverse voltage V <sub>R</sub> (V)	Operating temperature T <sub>opr</sub> (°C)	Storage temperature T <sub>stg</sub> (°C)
SML-A10MT	Green	55	20	60	4	-30 to +85	-40 to +85

\* I<sub>FP</sub> measured under duty ≤ 1/5, pulse width ≤ 1ms.

### Electrical Optical Characteristics (Ta=25°C)

Part No.	Resin Color	Forward voltage V <sub>F</sub>		Reverse current I <sub>R</sub>		Light wavelength			Brightness I <sub>v</sub>		
		Typ. (V)	I <sub>F</sub> (mA)	Max. (μA)	V <sub>R</sub> (V)	Peak λ <sub>p</sub> (nm)	Half-wave Δλ (nm)	I <sub>F</sub> (mA)	Min. (mcd)	Typ. (mcd)	I <sub>F</sub> (mA)
SML-A10MT	Transparent Clear	2.2	20	100	4	570	40	20	3.6	16	20

### External Dimensions (Unit : mm)

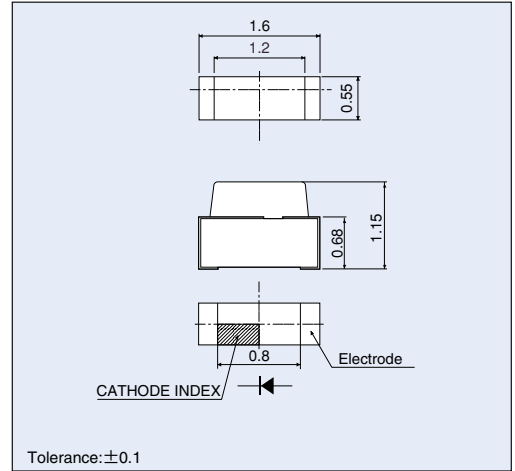

### Directivity

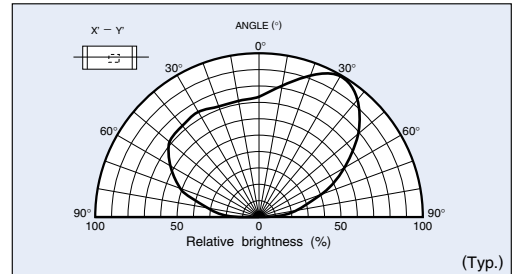

### Recommended Pad Layout

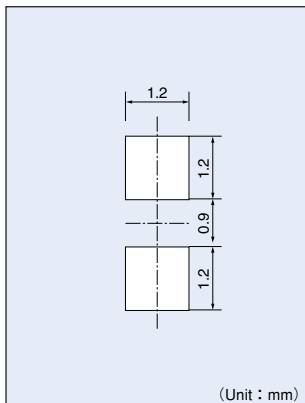

The recommended thickness of the screen mask for soldering is more than 150μm. The hole size of the screen mask should be same as the recommended land pattern or smaller.

### Packaging Specifications (Unit : mm)

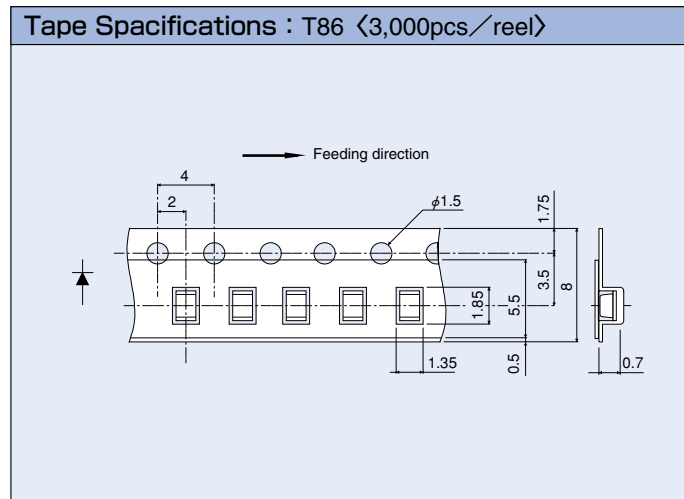

### Reel Specifications

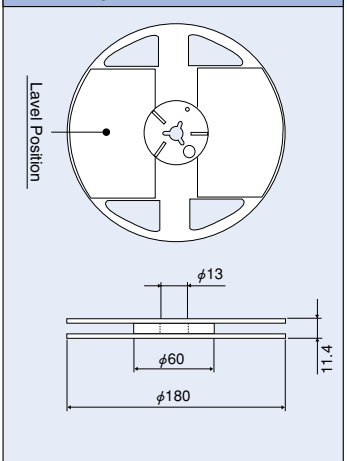

## Electrical Characteristic Curves

### Forward Current - Forward Voltage

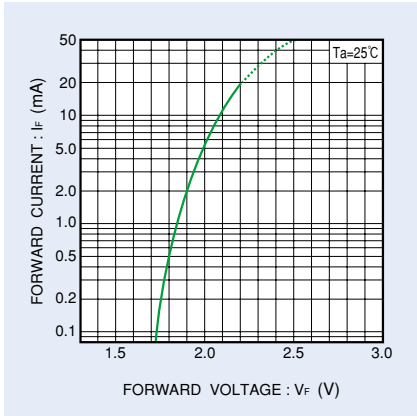

SML-A10MT

### Relative Luminous Intensity - Case Temperature

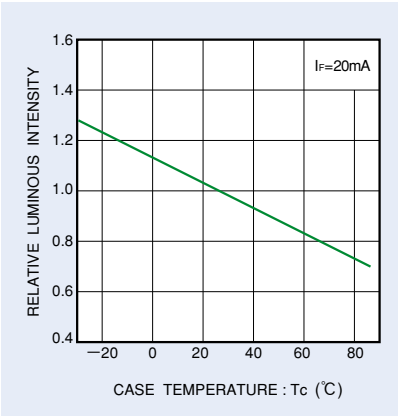

SML-A10MT

### Relative Luminous Intensity - Forward Current

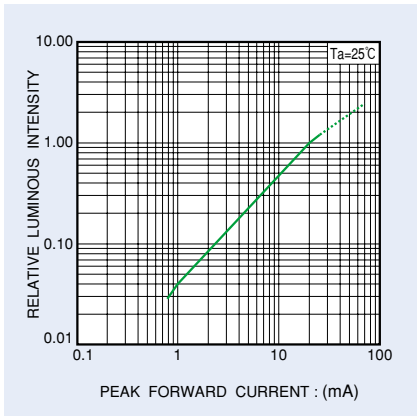

SML-A10MT

### Ratio of Maximum Tolerable Peak Current - Pulse Duration

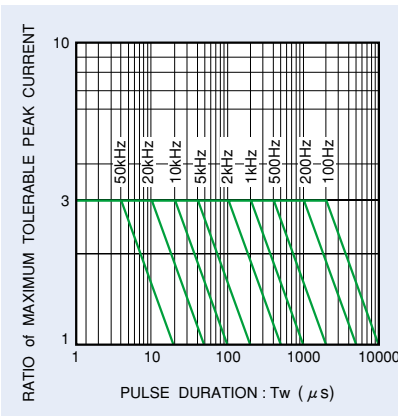

SML-A10MT

## Derating

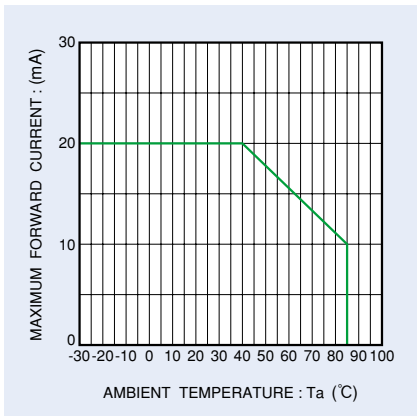

SML-A10MT

# Standard Type Back-fire chip LEDs (Reverse package)

## SML-810 Series

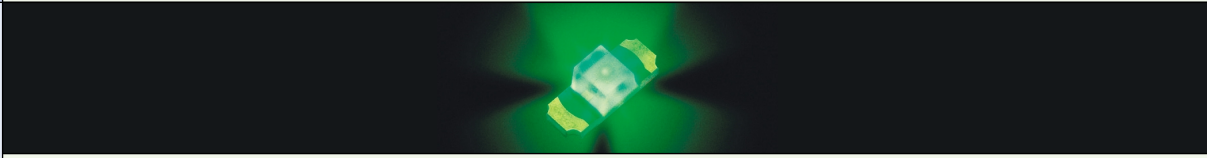
Package Size (mm)	Green
	GaP
	570nm
3412 (1305) 3.4×1.25 t=1.1	
SML-810MT	

### Absolute Maximum Ratings (Ta=25°C)

Part No.	Emitting color	Power dissipation Pd (mW)	Forward current IF (mA)	Peak forward current * IFP (mA)	Reverse voltage VR (V)	Operating temperature Topr (°C)	Storage temperature Tstg (°C)
SML-810MT	Green	65	25	60	4	-30 to +85	-40 to +85

\* IFP measured under duty ≤ 1/5, pulse width ≤ 1ms.

### Electrical Optical Characteristics (Ta=25°C)

Part No.	Resin Color	Forward voltage VF		Reverse current IR		Light wavelength			Brightness Iv		
		Typ. (V)	IF (mA)	Max. (μA)	VR (V)	Peak λp (nm)	Half-wave Δλ (nm)	IF (mA)	Min. (mcd)	Typ. (mcd)	IF (mA)
SML-810MT	Transparent Clear	2.2	20	100	4	570	40	20	5.6	16	20

### External Dimensions (Unit : mm)

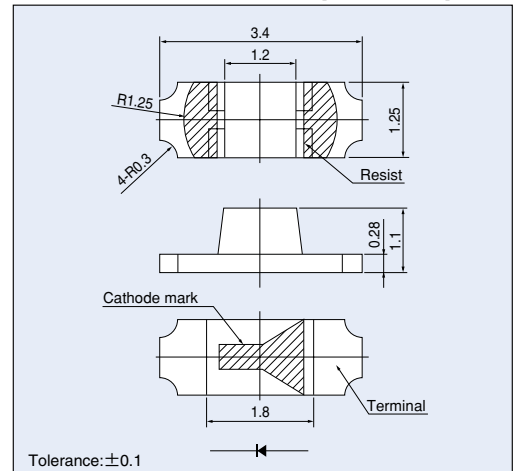

### Directivity

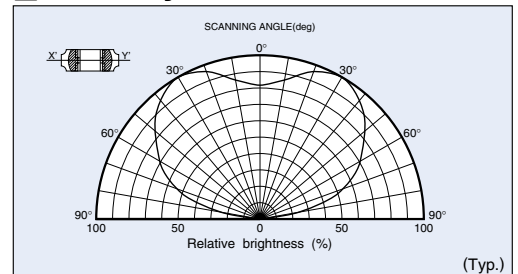

### Recommended Pad Layout

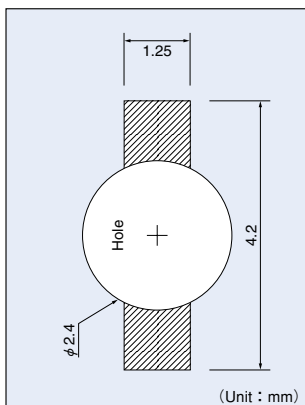

The recommended thickness of the screen mask for soldering is between 100 and 200μm. The hole size of the screen mask should be same as the recommended land pattern or smaller.

### Packaging Specifications (Unit : mm)

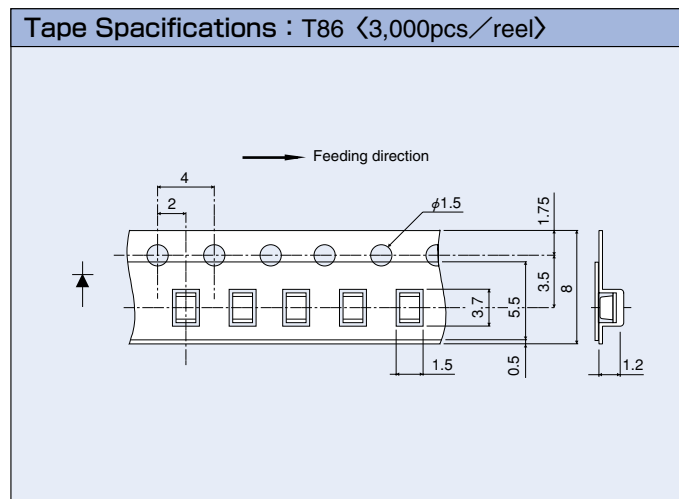

### Reel Specifications

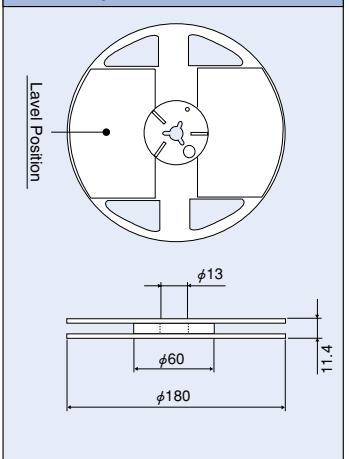

## Electrical Characteristic Curves

### Forward Current - Forward Voltage

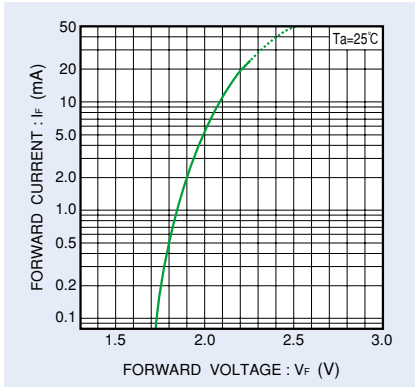

SML-810MT

### Relative Luminous Intensity - Case Temperature

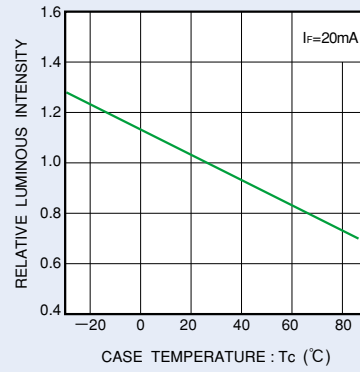

SML-810MT

### Relative Luminous Intensity - Forward Current

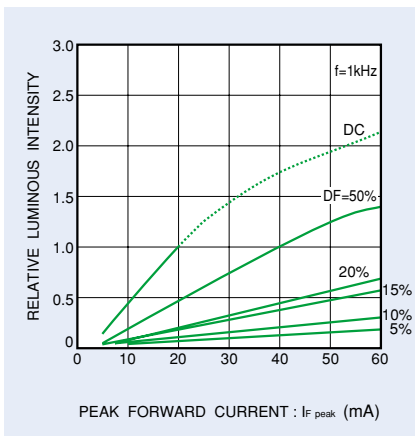

SML-810MT

### Ratio of Maximum Tolerable Peak Current - Pulse Duration

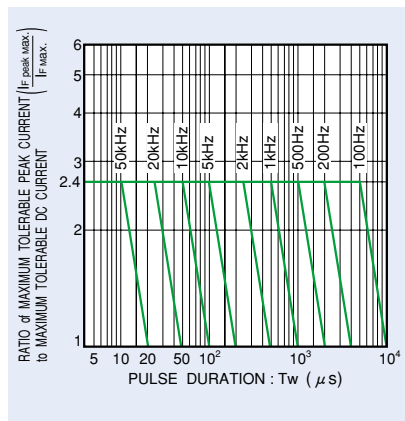

SML-810MT

## Derating

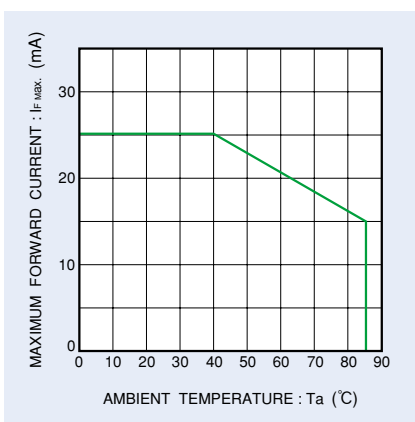

SML-810MT

### Notes

- No technical content pages of this document may be reproduced in any form or transmitted by any means without prior permission of ROHM CO.,LTD.
- The contents described herein are subject to change without notice. The specifications for the product described in this document are for reference only. Upon actual use, therefore, please request that specifications to be separately delivered.
- Application circuit diagrams and circuit constants contained herein are shown as examples of standard use and operation. Please pay careful attention to the peripheral conditions when designing circuits and deciding upon circuit constants in the set.
- Any data, including, but not limited to application circuit diagrams information, described herein are intended only as illustrations of such devices and not as the specifications for such devices. ROHM CO.,LTD. disclaims any warranty that any use of such devices shall be free from infringement of any third party's intellectual property rights or other proprietary rights, and further, assumes no liability of whatsoever nature in the event of any such infringement, or arising from or connected with or related to the use of such devices.
- Upon the sale of any such devices, other than for buyer's right to use such devices itself, resell or otherwise dispose of the same, no express or implied right or license to practice or commercially exploit any intellectual property rights or other proprietary rights owned or controlled by
- ROHM CO., LTD. is granted to any such buyer.
- Products listed in this document are no antiradiation design.

The products listed in this document are designed to be used with ordinary electronic equipment or devices (such as audio visual equipment, office-automation equipment, communications devices, electrical appliances and electronic toys).

Should you intend to use these products with equipment or devices which require an extremely high level of reliability and the malfunction of which would directly endanger human life (such as medical instruments, transportation equipment, aerospace machinery, nuclear-reactor controllers, fuel controllers and other safety devices), please be sure to consult with our sales representative in advance.

#### About Export Control Order in Japan

Products described herein are the objects of controlled goods in Annex 1 (Item 16) of Export Trade Control Order in Japan.

In case of export from Japan, please confirm if it applies to "objective" criteria or an "informed" (by MITI clause) on the basis of "catch all controls for Non-Proliferation of Weapons of Mass Destruction.