

Feature

- Low tolerance ($\pm 1\%$)
- Both flow and reflow soldering are applicable.
- Suitable size and packaging for surface mount assembly.
- Owing to the reduced lead inductance, the high frequency characteristic is excellent.

The product of lead-free terminal is RoHS compliant. PhO(lead oxide) is included in the glass of our product which is prescribed on RoHS appendix as an exception.

Application

- Circuit for high precision resistance and reliability.
- For signal control part
- For tuning circuit.

Structure and Dimensions

• Structure

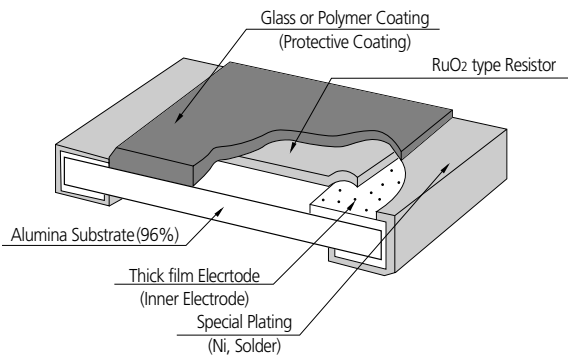

• Dimensions

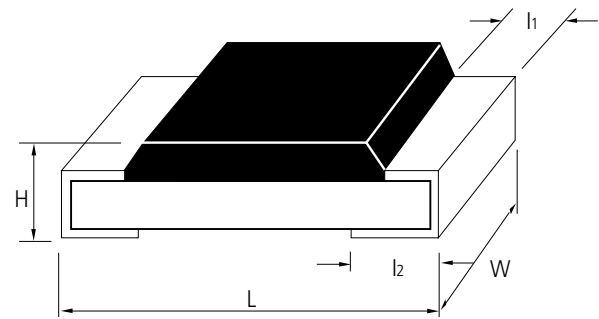

(UNIT: mm)

Type	Inch	Power(W)	L	W	H	l ₁	l ₂	Average Weight
RC 0603	0201	1/20	0.60 \pm 0.03	0.30 \pm 0.03	0.23 \pm 0.03	0.10 \pm 0.05	0.15 \pm 0.05	0.15mg
RC 1005	0402	1/16	1.00 \pm 0.05	0.50 \pm 0.05	0.35 \pm 0.05	0.20 \pm 0.10	0.25 \pm 0.10	0.6mg
RC 1608	0603	1/10	1.60 \pm 0.10	0.80 \pm 0.15	0.45 \pm 0.10	0.30 \pm 0.20	0.35 \pm 0.10	2.1mg
RC 2012	0805	1/8	2.00 \pm 0.20	1.25 \pm 0.15	0.50 \pm 0.10	0.40 \pm 0.20	0.35 \pm 0.20	4.9mg
RC 3216	1206	1/4	3.20 \pm 0.20	1.60 \pm 0.15	0.55 \pm 0.10	0.45 \pm 0.20	0.40 \pm 0.20	9.5mg
RC 3225	1210	1/3	3.20 \pm 0.20	2.55 \pm 0.20	0.55 \pm 0.10	0.45 \pm 0.20	0.40 \pm 0.20	16mg
RC 5025	2010	2/3	5.00 \pm 0.20	2.50 \pm 0.20	0.55 \pm 0.10	0.60 \pm 0.20	0.60 \pm 0.20	26mg
RC 6432	2512	1	6.30 \pm 0.20	3.20 \pm 0.20	0.55 \pm 0.10	0.60 \pm 0.20	0.60 \pm 0.20	41mg

Parts Numbering System

- The part number system shall be in the following format

RC	1005	F	2370	CS
Code Designation	Dimension & Size Code	Tolerance	Resistance Value	Packaging Code
RC: Chip Resistor	0603: 0.6 \times 0.3(mm) - 0201(inch) 1005: 1.0 \times 0.5(mm) - 0402(inch) 1608: 1.6 \times 0.8(mm) - 0603(inch) 2012: 2.0 \times 1.2(mm) - 0805(inch) 3216: 3.2 \times 1.6(mm) - 1206(inch) 3225: 3.2 \times 2.5(mm) - 1210(inch) 5025: 5.0 \times 2.5(mm) - 2010(inch) 6432: 6.4 \times 3.2(mm) - 2512(inch)	F: $\pm 1\%$	3 or 4 digits coding system (IEC coding system) 3digits (E-24 series) 4digits (E-96 series)	GS: Bulk Packaging CS: Tape Packaging 7" ES: Tape Packaging 10" FS: Tape Packaging 13" AS: Tape Packaging 13"

Specification

Type	Power Rating (W)	Working Voltage (MAX)	Overload Voltage (MAX)	TCR (ppm/°C)	Resistance Range (Ω)	Rated Ambient Temperature	Rated Working Temperature
					F(±1%) E-96, E-24		
RC0603	1/20	25(V)	50(V)	±250ppm	1 Ω~10MΩ	70°C	-55°C~+125°C
RC 1005	1/16	50(V)	100(V)	±100ppm			
RC 1608	1/10		200(V)				400(V)
RC 2012	1/8	-55°C~+155°C					
RC 3216	1/4						
RC 3225	1/3	-55°C~+125°C					
RC 5025	2/3						
RC 6432	1						

- Rated voltage (V) = $\sqrt{\text{Rated power(W)} \times \text{Normal resistance value (R)}}$
Rated voltage should be lower than (MAX) working voltage.

Power Derating Curve

The rated power is the maximum continuous loading power at 70°C ambient temperature.
For ambient temperature above 70°C, the loading power follows the below power derating curve.

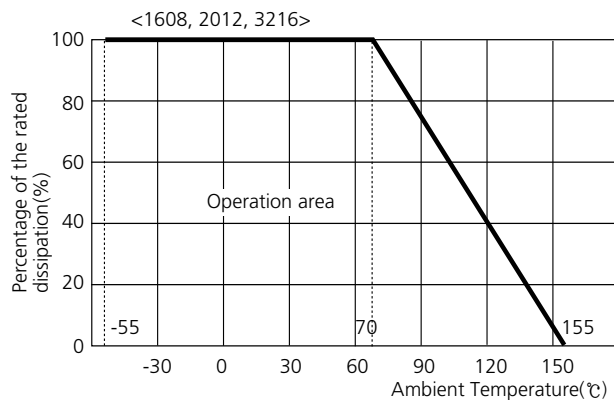
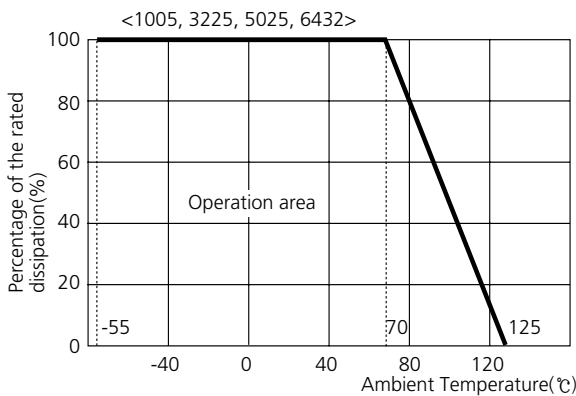

Marking

• 3 digits indication (E-24 series)	• 4 digits indication (E-96 series)
<ul style="list-style-type: none"> - Left 2 digits represent significant figures. - Last 1 digit represents exponential number of 10. - Example: 103 Left 2 digits: 10 Last 1 digit: 3 $103 = 10 \times 10^3 \Omega$ $= 10000 \Omega = 10k\Omega$ 	<ul style="list-style-type: none"> - Left 3 digits represent significant figures. - Last 1 digit represents exponential number of 10. - Example: 1002 Left 3 digits: 100 Last 1 digit: 2 $1002 = 100 \times 10^2 \Omega$ $= 10000 \Omega = 10k\Omega$
• 0603, 1005 type: No marking.	• 0603, 1005, 1608 type: No marking.

IEC Code System (E-96, E-24)

E-96	E-24	E-96	E-24	E-96	E-24	E-96	E-24
100	10	178		316		562	56
102		182	18	324	33	576	
105		187		332		590	
107		191		340		604	
110	11	196		348		619	
113		200	20	357	36	634	62
115		205		365		649	
118		210		374		665	
121	12	215		383	39	681	68
124		221	22	392		698	
127		226		402		715	
130	13	232		412		732	
133		237		422		750	75
137		243	24	432	43	768	
140		249		442		787	
143		255		453		806	
147		261		464		825	82
150	15	267		475	47	845	
154		274	27	487		866	
158		280		499		887	
162	16	287		511	51	909	
165		294		523		931	91
169		301	30	536		953	
174		309		549		976	

Operation Notes

Example of Land Pattern Design

Recommended Soldering Conditions

General Purpose

Precision

Low Ohms

Array

Attenuator

Characteristics Performance

Packaging

Standard Resistance Value