Multilayer Ceramic Capacitor

- High Voltage -



Multilayer Ceramic Capacitor - High Voltage

■ INTRODUCTION

SAMSUNG (Electro-Mechanics) mid/high voltage MLCC products with COG(NP0) and X7R temperature characteristics are designed for commercial and industrial applications up to DC 3 KV, including power supply and voltage multiplier circuits applications. The specially-designed internal and external structures are capable of enhancing high voltage performance of chips. Various sizes and voltage ratings are available for corresponding capacitance ranges. Please contact and consult the local offices/headquarter of SAMSUNG Electro-Mechanics.

■ FEATURE AND APPLICATION

● Feature

- Miniature Size
- Wide Capacitance and Voltage Range
- Highly Reliable Performance in High-voltage
- Tape & Reel for Surface Mount Assembly
- Low ESR

● Application

- Input Signal Filtering Circuit of Modem and LAN Interface
- General High Voltage Circuits
- Inverter Circuits with a Liquid Backlight

Multilayer Ceramic Capacitor - High Voltage

■ STRUCTURE

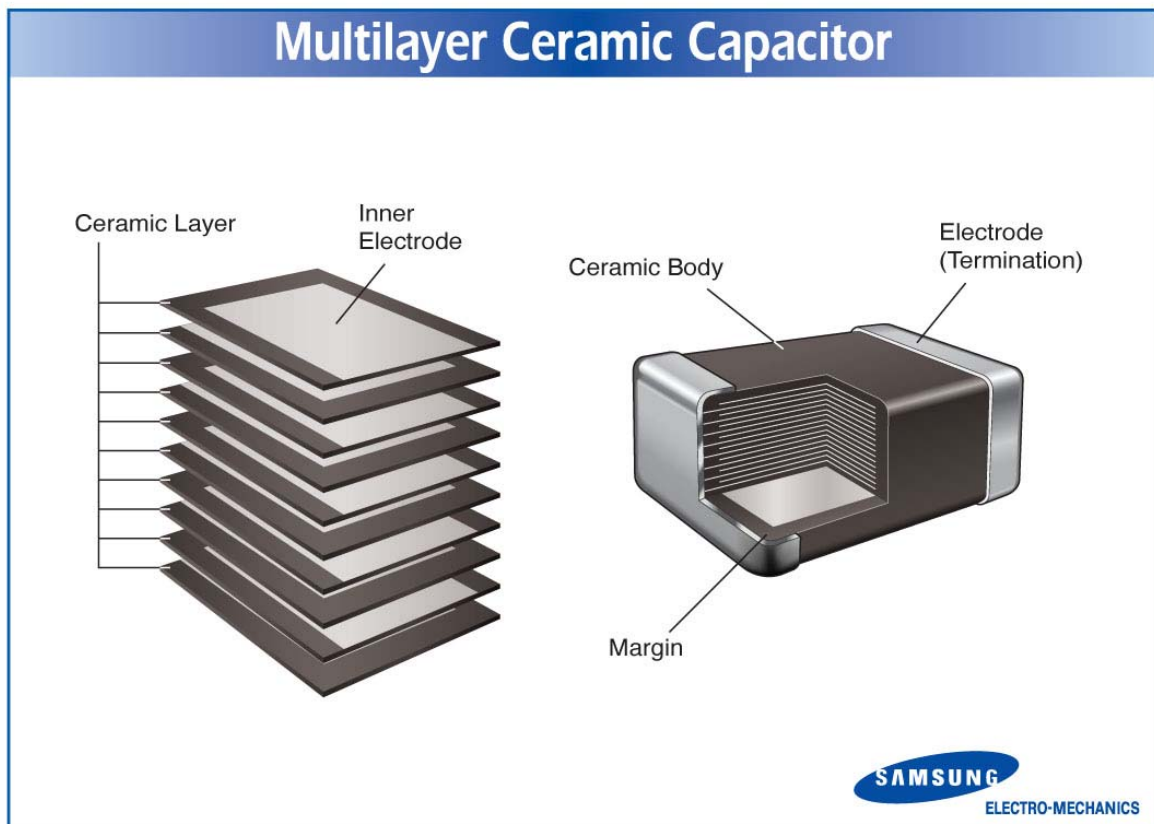

Multilayer Ceramic Capacitor - High Voltage

■ APPEARANCE AND DIMENSION

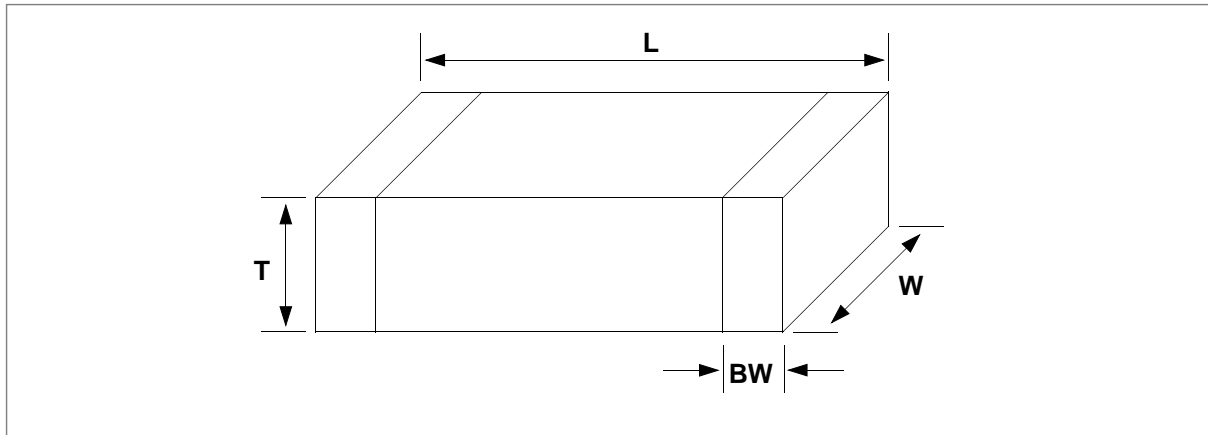

CODE	EIA CODE	DIMENSION (mm)			
		L	W	T (MAX)	BW
10	0603	1.6 ± 0.1	0.8 ± 0.1	0.8 ± 0.1	$0.3 + 0.2/-0.1$
21	0805	2.0 ± 0.1	1.25 ± 0.1	1.25 ± 0.1	$0.5 + 0.2/-0.3$
31	1206	3.2 ± 0.2	1.6 ± 0.2	1.6 ± 0.2	$0.5 + 0.2/-0.3$
32	1210	3.2 ± 0.3	2.5 ± 0.2	2.5 ± 0.2	$0.6 + 0.2/-0.1$
42	1810	4.5 ± 0.4	2.0 ± 0.2	2.0 ± 0.2	$0.8 + 0.2/-0.1$
43	1812	4.5 ± 0.4	3.2 ± 0.3	2.5 ± 0.2	$0.8 + 0.2/-0.1$
55	2220	5.7 ± 0.4	3.2 ± 0.4	2.5 ± 0.2	$0.8 + 0.2/-0.1$

Multilayer Ceramic Capacitor - High Voltage

PREVIOUS PART NUMBERING

<u>CL</u>	<u>42</u>	<u>C</u>	<u>270</u>	<u>J</u>	<u>K</u>	<u>N</u>	<u>E</u>
①	②	③	④	⑤	⑥	⑦	⑧

- ① SAMSUNG Multilayer Ceramic Capacitor
- ② Type(Size)
- ③ Capacitance Temperature Characteristics
- ④ Nominal Capacitance
- ⑤ Capacitance Tolerance
- ⑥ Rated Voltage
- ⑦ Thickness Option
- ⑧ Packaging Type

③ CAPACITANCE TEMPERATURE CHARACTERISTIC

▶ CLASS I (Temperature Compensation)

Symbol	EIA Code	Temperature Coefficient(PPM/°C)	※ Temperature Characteristics	Operation Temperature Range
C	C0G(CH)	0 ± 30	CΔ	-55 ~ +125°C

※ Temperature Characteristics

Temperature Characteristics	below 2.0pF	2.2 ~ 3.9pF	above 4.0pF	above 10pF
CΔ	C0G	C0G	C0G	C0G

▶ CLASS II (High Dielectric Constant)

Symbol	EIA Code	Capacitance Change (ΔC : %)	Operation Temperature Range
B	X7R	± 15	-55 ~ +125°C

Multilayer Ceramic Capacitor - High Voltage

④ NOMINAL CAPACITANCE

The nominal capacitance value is expressed in pico-Farad(pF) and identified by three-digit number, first two digits represent significant figures and last digit specifies the number of zeros to follow. For values below 1pF, the letter "R" is used as the decimal point and the last digit becomes significant.

example)

100	:	$10 \times 10^0 =$	10pF
102	:	$10 \times 10^2 =$	1000pF
020	:	$2 \times 10^0 =$	2pF
1R5	:		1.5pF

⑤ CAPACITANCE TOLERANCE

Temperature Characteristics	Symbol	Tolerance	Applicable Capacitance & Range
C (C0G)	C	$\pm 0.25\text{pF}$	0.5 ~ 10pF
	D	$\pm 0.5\text{pF}$	
	J	$\pm 5\%$	E-24 Series for over 10pF
	K	$\pm 10\%$	
	M	$\pm 20\%$	
B(X7R)	J	$\pm 5\%$	E-12 Series
	K	$\pm 10\%$	
	M	$\pm 20\%$	

※ Please Consult us for special tolerances.

* : Option

⑥ RATED VOLTAGE

Symbol	Rated Voltage(Vdc)	Symbol	Rated Voltage(Vdc)
C	100Vdc	H	630Vdc
D	200Vdc	I	1000Vdc
E	250Vdc	J	2000Vdc
G	500Vdc	K	3000Vdc

Multilayer Ceramic Capacitor - High Voltage

⑦ THICKNESS OPTION

Symbol	Description of the Code
N	Standard thickness (please refer to standard thickness table on next page)
A	Thinner than standard thickness
B	Thicker than standard thickness

※ Please consult us for other termination type.

⑧ PACKAGING TYPE

Symbol	Packaging	Symbol	Packaging
B	Bulk	D	Paper Tape, 13" Reel
P	Cassette	E	Embossed Tape, 7" Reel
C	Paper Tape, 7" Reel	F	Embossed Tape, 13" Reel

▶ STANDARD CAPACITANCE STEP

Series	Capacitance Step											
E- 3	1.0				2.2				4.7			
E- 6	1.0	1.5		2.2	3.3		4.7	6.8				
E-12	1.0	1.2	1.5	1.8	2.2	2.7	3.3	3.9	4.7	5.6	6.8	8.2
E-24	1.0	1.2	1.5	1.8	2.2	2.7	3.3	3.9	4.7	5.6	6.8	8.2
	1.1	1.3	1.6	2.0	2.4	3.0	3.6	4.3	5.1	6.2	7.5	9.1

※ Standard Capacitance is " Each step $\times 10^n$ "

Multilayer Ceramic Capacitor - High Voltage

■ NEW PART NUMBERING

CL	42	C	270	J	K	F	N	N	N	C
①	②	③	④	⑤	⑥	⑦	⑧	⑨	⑩	⑪

- ① SAMSUNG Multilayer Ceramic Capacitor
- ② Size(mm)
- ③ Capacitance Temperature Characteristic
- ④ Nominal Capacitance
- ⑤ Capacitance Tolerance
- ⑥ Rated Voltage
- ⑦ Thickness Option
- ⑧ Product & Plating Method
- ⑨ Samsung Control Code
- ⑩ Reserved For Future Use
- ⑪ Packaging Type

① PRODUCT ABBREVIATION

Symbol	Product Abbreviation
CL	SAMSUNG Multilayer Ceramic Capacitor

② SIZE(mm)

Symbol	Size(mm)	
	Length	Width
10	1.6	0.8
21	2.0	1.2
31	3.2	1.6
32	3.2	2.5
42	4.5	2.0
43	4.5	3.2
55	5.7	5.0

Multilayer Ceramic Capacitor - High Voltage

③ CAPACITANCE TEMPERATURE CHARACTERISTIC

Symbol	Temperature Characteristics				Temperature Range
C	Class I	COG	C Δ	0 \pm 30(ppm/ $^{\circ}$ C)	-55 ~ +125 $^{\circ}$ C
B	Class II	X7R	X7R	\pm 15%	-55 ~ +125 $^{\circ}$ C

※ Temperature Characteristic

Temperature Characteristics	Below 2.0pF	2.2 ~ 3.9pF	Above 4.0pF	Above 10pF
C Δ	COG	COG	COG	COG

④ NOMINAL CAPACITANCE

Nominal capacitance is identified by 3 digits.

The first and second digits identify the first and second significant figures of the capacitance.

The third digit identifies the multiplier. 'R' identifies a decimal point.

● Example

Symbol	Nominal Capacitance
1R5	1.5pF
103	10,000pF, 10nF, 0.01 μ F
104	100,000pF, 100nF, 0.1 μ F

⑤ CAPACITANCE TOLERANCE

Symbol	Tolerance	Nominal Capacitance
C	\pm 0.25pF	Less than 10pF (Including 10pF)
D	\pm 0.5pF	
J	\pm 5%	More than 10pF
K	\pm 10%	
M	\pm 20%	

Multilayer Ceramic Capacitor - High Voltage

⑥ RATED VOLTAGE

Symbol	Rated Voltage	Symbol	Rated Voltage
C	100V	H	630V
D	200V	I	1,000V
E	250V	J	2,000V
G	500V	K	3,000V

⑦ THICKNESS OPTION

Type	Symbol	Thickness(T)	Spec
1608	8	0.80	±0.10
2012	A	0.65	±0.10
	C	0.85	
	F	1.25	±0.10
3216	C	0.85	±0.15
	F	1.25	±0.15
	H	1.6	±0.20
3225	F	1.25	±0.20
	H	1.6	
	I	2.0	
	J	2.5	
4520	F	1.25	±0.20
	H	1.6	
4532	F	1.25	±0.20
	H	1.6	
	I	2.0	
	J	2.5	
5750	F	1.25	±0.20
	H	1.6	
	I	2.0	
	J	2.5	

Multilayer Ceramic Capacitor - High Voltage

⑧ PRODUCT & PLATING METHOD

Symbol	Electrode	Termination	Plating Type
A	Pd	Ag	Sn_100%
N	Ni	Cu	Sn_100%
G	Cu	Cu	Sn_100%

⑨ SAMSUNG CONTROL CODE

Symbol	Description of the code	Symbol	Description of the code
A	Array (2-element)	N	Normal
B	Array (4-element)	P	Automotive
C	High - Q	W	3 Terminal EMI Filter
L	LICC		

⑩ RESERVED FOR FUTURE USE

Symbol	Description of the code
N	Reserved for future use

⑪ PACKAGING TYPE

Symbol	Packaging Type	Symbol	Packaging Type
B	Bulk	F	Embossing 13" (10,000EA)
P	Bulk Case	L	Paper 13" (15,000EA)
C	Paper 7"	O	Paper 10"
D	Paper 13" (10,000EA)	S	Embossing 10"
E	Embossing 7"		

Multilayer Ceramic Capacitor - High Voltage

► CAPACITANCE vs CHIP THICKNESS STANDARD

Description		1608 (0603)	2012 Type (0805)				3216 Type (1206)			3225 Type (1210)				4520 Type (1808)		4532 Type (1812)				5750 Type (2220)		
Dimension (mm)	L	1.6 ±0.1	2.0±0.1				3.2±0.15			3.2±0.3				4.5±0.4		4.5±0.4				5.7±0.4		
	W	0.8 ±0.1	1.25±0.1				1.6±0.15			2.5±0.2				2.0±0.2		3.2±0.3				5.0±0.4		
	T	0.8 ±0.1	0.65 ±0.1	0.85 ±0.1	1.25 ±0.1	0.85 ±0.15	1.25 ±0.15	1.6 ±0.2	1.25 ±0.2	1.6 ±0.2	2.0 ±0.2	2.5 ±0.2	1.25 ±0.2	1.6 ±0.2	1.25 ±0.2	1.6 ±0.2	2.0 ±0.2	2.5 ±0.2	1.6 ±0.2	2.0 ±0.2	2.5 ±0.2	
CAPACITANCE RANGE (pF)	SL	100V	0.5- 680	0.5- 560	620- 910	1000	0.5- 1500	1600- 3300	3600- 3900	-	-	-	-	-	-	-	-	-	-	-	-	-
	C, TC (Except SL,UJ)	100V	0.5- 390	0.5- 390	470- 820	1000	0.5- 2200	2700- 3300	3900- 6800	4700- 6800	8200- 10000	12000	15000- 18000	-	-	10000- 15000	18000	22000	27000- 33000	-	-	-
		200V	-	-	33- 470	560- 1000	220- 680	820- 1200	1500- 2700	3300	3900	4700	5600- 8200	-	-	-	-	-	10000- 18000	-	-	-
		250V	-	-	-	680	-	-	2200	-	-	-	6800	-	-	-	-	-	12000	-	-	22000
		500V	-	-	-	-	-	10- 560	680- 1000	470- 1000	1200- 1500	-	-	-	-	470- 1500	1800- 2200	2700	3300- 5600	-	6800	8200- 10000
		630V	-	-	-	-	-	-	820	-	-	-	2200	-	-	-	-	-	4700	-	-	10000
		1kV	-	-	-	-	-	10- 150	180- 270	-	470- 560	680	820	-	-	470- 680	820- 1000	1200	1500- 1800	-	-	2200- 3600
		2kV	-	-	-	-	-	-	10-47	47- 180	220	270- 330	470	10- 150	180- 220	47- 120	150- 180	220	270- 390	-	-	-
		3kV	-	-	-	-	-	-	-	-	-	-	-	10- 100	-	-	100- 180	220	270- 390	-	-	470- 820
CAPACITANCE RANGE (nF)	(X7R)	100V	0.47- 10	0.22- 10	15	22- 68	1- 47	68- 100	150	2.2- 150	220	-	-	-	-	100- 330	470	-	-	680- 1000	1500	-
		200V	-	-	0.22-1 0	-	0.47- 22	33- 47	68- 100	-	-	-	-	-	-	47- 100	-	-	-	-	-	-
		250V	-	-	1- 3.3	4.7-1 5	-	22	33- 47	-	-	68	100	-	-	-	-	150- 220	-	-	330- 470	
		500V	-	-	-	-	-	0.47- 15	22- 33	10- 33	470	-	-	-	-	10- 47	68	100	-	150	220	-
		630V	-	-	-	-	-	-	-	-	-	-	-	-	-	-	-	-	-	-	-	-
		1kV	-	-	-	-	-	0.47- 3.3	-	3.3- 6.8	-	-	-	-	-	1.5- 10	15- 22	-	33	-	47	68
		2kV	-	-	-	-	-	-	0.47- 1	0.47- 1	-	-	-	-	1	-	1- 3.3	-	-	-	3.3- 10	-

Multilayer Ceramic Capacitor - High Voltage

PACKAGING

CARDBOARD PAPER TAPE

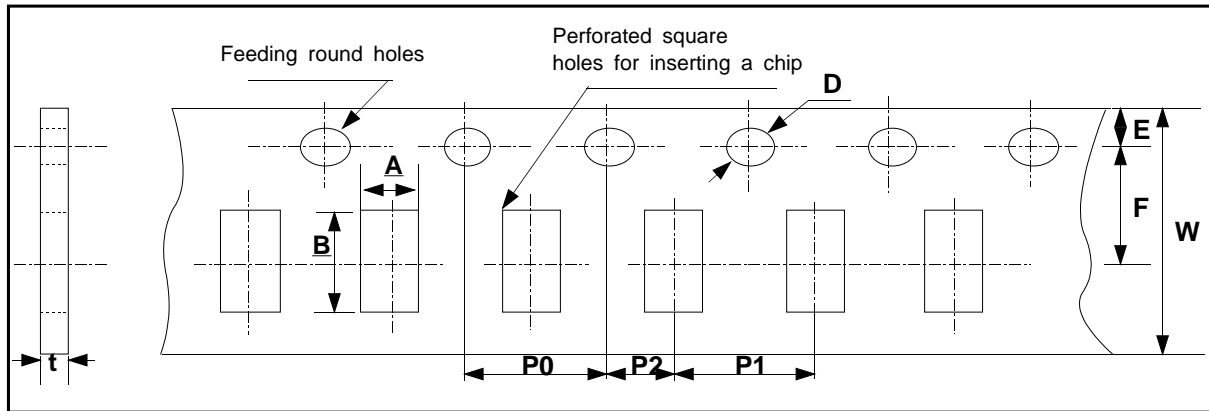

unit : mm

Symbol		W	F	E	P1	P2	P0	D	t	A	B
Type											
D i m e n s i o n	10									1.1 ±0.2	1.9 ±0.2
	21	8.0 ±0.3	3.5 ±0.05	1.75 ±0.1	4.0 ±0.1	2.0 ±0.05	4.0 ±0.1	φ1.5 +0.1/-0	1.1 Max	1.6 ±0.2	2.4 ±0.2
	31									2.0 ±0.2	3.6 ±0.2

EMBOSED PLASTIC TAPE

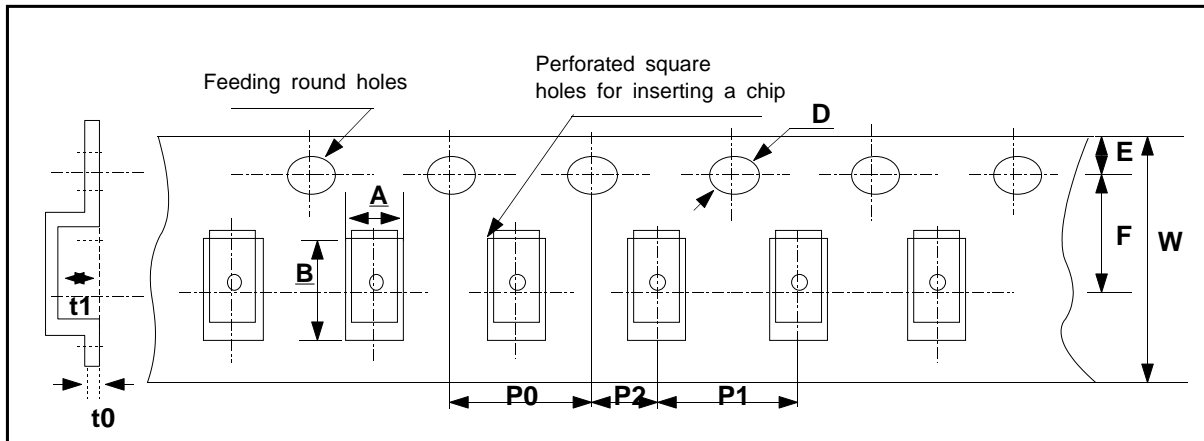

unit : mm

Symbol		W	F	E	P1	P2	P0	D	t0	t1	A	B
Type												
D i m e n s i o n	21										1.45 ±0.2	2.3 ±0.2
	31	8.0 ±0.3	3.5 ±0.05	1.75 ±0.1	4.0 ±0.1	2.0 ±0.05	4.0 ±0.1	φ1.5 +0.1/-0	0.6 Max	2.5 max	2.0 ±0.2	3.6 ±0.2
	32										2.9 ±0.2	3.6 ±0.2
	43 (42)	12 ±0.3	5.6 ±0.05		8.0 ±0.1						3.8 max	2.5(3.6) ±0.2

Multilayer Ceramic Capacitor - High Voltage

● TAPING SIZE

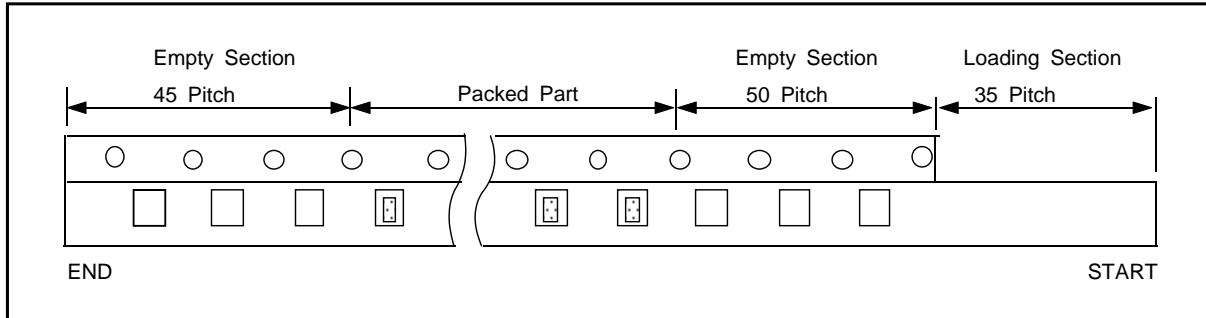

unit : pcs

Symbol	Cardboard Paper Tape	Embossed Plastic Tape
7" Reel	4000	2000
13" Reel	15000	-

● REEL DIMENSION

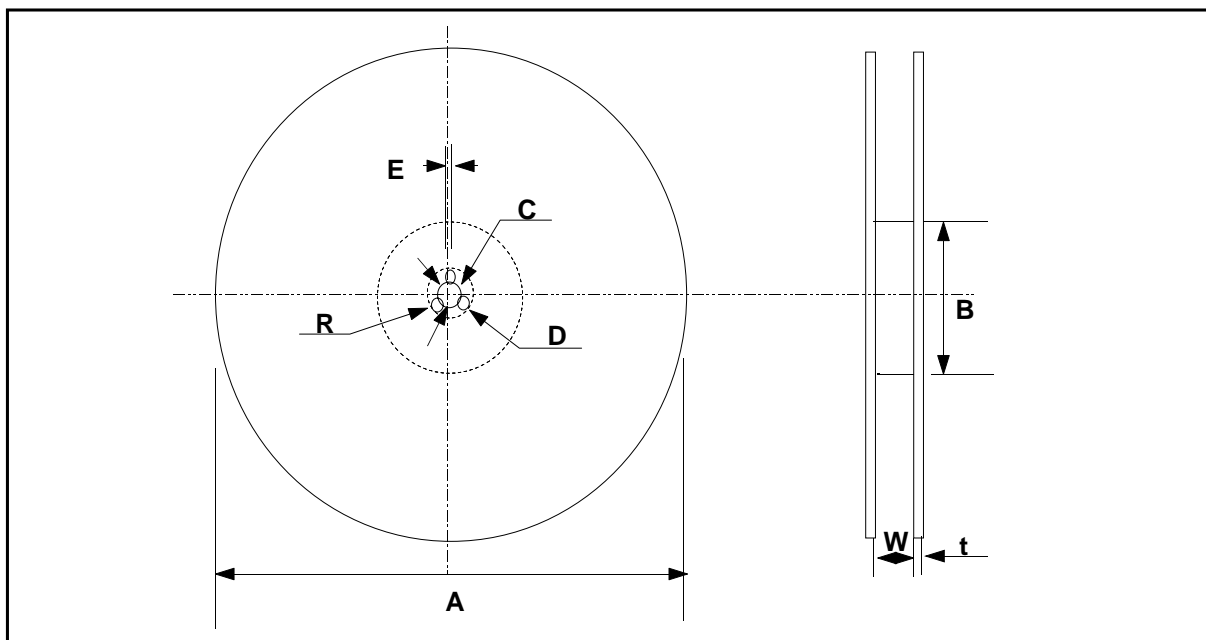

unit : mm

Symbol	A	B	C	D	E	W	t	R
7" Reel	$\phi 178 \pm 2.0$	min. $\phi 50$	$\phi 13 \pm 0.5$	21 ± 0.8	2.0 ± 0.5	10 ± 1.5	0.8 ± 0.2	1.0
13" Reel	$\phi 330 \pm 2.0$	min. $\phi 70$						

Multilayer Ceramic Capacitor - High Voltage

● BULK CASE PACKAGING

- Bulk case packaging can reduce the stock space and transportation costs.
- The bulk feeding system can increase the productivity.
- It can eliminate the components loss.

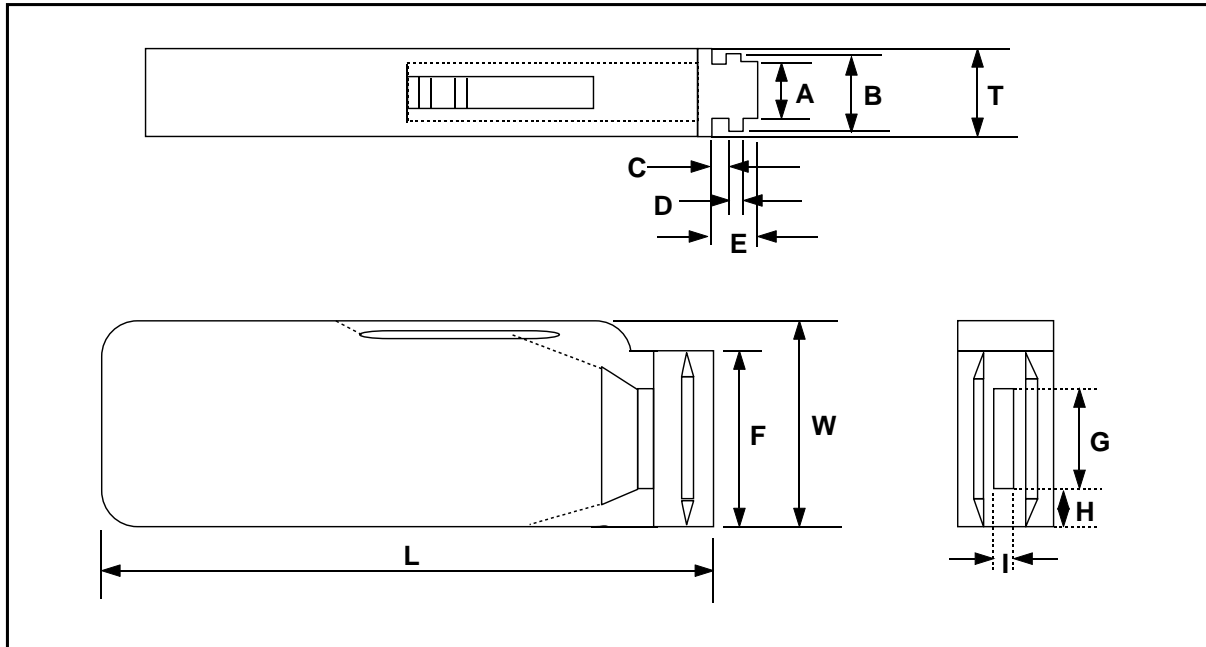

Symbol	A	B	T	C	D	E
Dimension	6.8 ± 0.1	8.8 ± 0.1	12 ± 0.1	$1.5 + 0.1 / - 0$	$2 + 0 / - 0.1$	4.7 ± 0.1

Symbol	F	W	G	H	L	I
Dimension	$31.5 + 0.2 / - 0$	$36 + 0 / - 0.2$	19 ± 0.35	7 ± 0.35	110 ± 0.7	5 ± 0.35

● QUANTITY

Size	05(0402)	10(0603)	21(0805)	
			$T \leq 0.85\text{mm}$	$T \geq 1.0\text{mm}$
Quantity	80,000	10,000~15,000	10,000	5,000

Multilayer Ceramic Capacitor - High Voltage

● CLASS II , B(X7R)

Temperature Characteristics	Size	Voltage	Capacitance Range (pF)										
			10	100	1000	10000	100000	1000000	10000000	100000000			
B(X7R)	10 (0603)	100V			470			10000					
	21 (0805)	100V			220			68000					
		200V			220			10000					
		250V				1000		15000					
	31 (1206)	100V				1000		150000					
		200V				470		100000					
		250V					22000	47000					
		500V				470		33000					
		1000V				470		3300					
		2000V				470		1000					
	32 (1210)	100V				2200		220000					
		250V					68000	100000					
		500V					10000	470000					
		1000V					3300	6800					
		2000V				470		1000					
	42(1808)	2000V					1000						
	43 (1812)	100V						100000	330000				
		200V						47000	100000				
		250V						150000	220000				
		500V					10000	100000					
		1000V					1500	33000					
		2000V					1000	3300					
	55 (2220)	100V						680000	1500000				
		250V						330000	470000				
		500V						150000	220000				
		1000V						47000	68000				
		2000V						3300	10000				

Multilayer Ceramic Capacitor - High Voltage

RELIABILITY TEST DATA

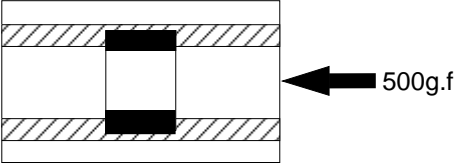
NO	ITEM	PERFORMANCE	TEST CONDITION														
1	APPEARANCE	NO ABNORMAL EXTERIOR APPEARANCE	THROUGH MICROSCOPE(×10)														
2	INSULATION RESISTANCE	10,000MΩ OR 500MΩ·μF PRODUCT WHICHEVER IS SMALLER (RATED VOLTAGE IS BELOW 16V : 10,000MΩ OR 100MΩ·μF)	RATED VOLTAGE SHALL BE APPLIED. MEASUREMENT TIME IS 60 ~ 120sec RATED VOLTAGE TIME 60 SEC.														
3	WITHSTANDING VOLTAGE	NO DIELECTRIC BREAKDOWN OR MECHANICAL BREAKDOWN	<table border="1"> <tr> <td>Rated voltage</td> <td>Applied voltage</td> </tr> <tr> <td>Vr<500Vdc</td> <td>200% of Vr</td> </tr> <tr> <td>500Vdc≤Vr<1000Vdc</td> <td>150% of Vr</td> </tr> <tr> <td>1000Vdc≤Vr</td> <td>120% of Vr</td> </tr> </table> <p>VOLTAGE APPLIED in 1~5 sec CURRENT APPLIED : 50mA BELOW</p>	Rated voltage	Applied voltage	Vr<500Vdc	200% of Vr	500Vdc≤Vr<1000Vdc	150% of Vr	1000Vdc≤Vr	120% of Vr						
Rated voltage	Applied voltage																
Vr<500Vdc	200% of Vr																
500Vdc≤Vr<1000Vdc	150% of Vr																
1000Vdc≤Vr	120% of Vr																
4	CAPACITANCE	CLASS I WITHIN THE SPECIFIED TOLERANCE	CAPACITANCE	FREQUENCY	VOLTAGE												
			1,000pF AND BELOW	1Mhz±10%	0.5 ~ 5 Vrms												
		CLASS II WITHIN THE SPECIFIED TOLERANCE	FREQUENCY		VOLTAGE												
			MORE THAN 1,000pF	1kHz±10%	1.0±0.2Vrms												
5	Q	CLASS I OVER 30pF : Q ≥1,000 LESS THAN 30pF: Q ≥400 +20C (C : CAPACITANCE)	CAPACITANCE	FREQUENCY	VOLTAGE												
			1,000pF AND BELOW	1Mhz±10%	0.5 ~ 5 Vrms												
			MORE THAN 1,000pF	1kHz±10%													
			FREQUENCY		VOLTAGE												
6	Tanδ (DF)	CLASS II B : 2.5% Max (0.025 Max) C : 0.1% MAX (0.001Max)	FREQUENCY		VOLTAGE												
			1kHz±10%		1.0±0.2Vrms												
7	TEMPERATURE COEFFICIENT CHARACTERISTICS	C	TEMP. COEFFICIENT	0±30(ppm/°C)	<p>THE TEMPERATURE COEFFICIENT IS CALCULATED IN ppm/°C FOR GIVEN TEMPERATURE(T1=25°C ,T1=85°C)</p> <p>TEST STEP</p> <table border="1"> <tr> <th>Step</th> <th>TEMPERATURE(°C)</th> </tr> <tr> <td>1</td> <td>25±2</td> </tr> <tr> <td>2</td> <td>MIN. OPERATING TEMP.±2</td> </tr> <tr> <td>3</td> <td>25±2</td> </tr> <tr> <td>4</td> <td>MAX. OPERATING TEMP.±2</td> </tr> <tr> <td>5</td> <td>25±2</td> </tr> </table> <p>* MEASURE THE CAPACITANCE IN EACH STEP AT THERMAL EQUILIBRIUM</p>	Step	TEMPERATURE(°C)	1	25±2	2	MIN. OPERATING TEMP.±2	3	25±2	4	MAX. OPERATING TEMP.±2	5	25±2
		Step	TEMPERATURE(°C)														
1	25±2																
2	MIN. OPERATING TEMP.±2																
3	25±2																
4	MAX. OPERATING TEMP.±2																
5	25±2																
B	CAPACITANCE CHANGE	±15%															
8	ADHESIVE STRENGTH OF TERMINATION	NO INDICATION OF PEELING OCCUR ON THE TERMINAL ELECTRODE.	<p>A 500g.f PRESSURE SHALL BE APPLIED FOR 10±1 SECONDS.</p> 														

Multilayer Ceramic Capacitor - High Voltage

NO	ITEM	PERFORMANCE	TEST CONDITION									
9	BENDING STRENGTH	APPEARANCE	NO MECHANICAL DAMAGE SHALL OCCUR.									
		CAPACITANCE	CHARACTER	CHANGE OF CAPACITANCE								
	C(C0G)		WITHIN $\pm 5\%$ OR ± 0.5 pF WHICHEVER IS LARGER									
			B(X7R)	WITHIN $\pm 12.5\%$								
			<p>BENDING SHALL BE APPLIED TO THE LIMIT(1mm) WITH 0.3mm/SEC.</p>									
10	SOLDERABILITY	<p>MORE THAN 75% OF THE TERMINAL SURFACE IS TO BE SOLDERED NEWLY. THERE MAY BE PINHOLES, SPOTS. BUT THESE MUST NOT BE AT ONE POINT</p> <p>IN PB--FREE PART, MORE THAN 95% OF THE TERMINAL SURFACE IS TO BE SOLDERED NEWLY</p>	<p>SOLDER TEMPERATURE : $230\pm 5^\circ\text{C}$ IMMERSED DEPTH : 10 ~15 mm SOLDER : H63A FLUX : ROSIN *PB-FREE SOLDER TEMPERATURE : $260\pm 5^\circ\text{C}$ SOLDER : Sn96.5-3Ag-0.5Cu Flux : RMA TYPE DIP TIME : 3 ± 0.1Sec PRE-HEATING : AT $80\sim 120^\circ\text{C}$ FOR 10~30SEC.</p>									
11	RESISTANCE TO SOLDERING HEAT	APPEARANCE	NO MECHANICAL DAMAGE SHALL OCCUR									
		CAPACITANCE	CHARACTERISTIC	CAP. CHANGE								
			CLASS I	WITHIN $\pm 2.5\%$ OR ± 0.25 pF WHICHEVER IS LARGER								
				CLASS II	B WITHIN $\pm 7.5\%$							
			F WITHIN $\pm 20\%$									
		Q	30 pF AND OVER : $Q \geq 1000$ LESS THAN 30 pF : $Q \geq 400+20 \times C$									
		Tan δ	TO SATISFY THE SPECIFIED INITIAL VALUE									
		INSULATION RESISTANCE	TO SATISFY THE SPECIFIED INITIAL VALUE									
WITHSTANDING VOLTAGE	TO SATISFY THE SPECIFIED INITIAL VALUE											
			<p>DIP : SOLDER TEMPERATURE OF $270\pm 5^\circ\text{C}$ DIP TIME : 10 ± 1 SEC. EACH TERMINATION SHALL BE FULLY IMMERSSED AND PREHEATED AS FOLLOWING:</p> <table border="1"> <thead> <tr> <th>STEP</th> <th>TEMP.($^\circ\text{C}$)</th> <th>TIME (SEC.)</th> </tr> </thead> <tbody> <tr> <td>1</td> <td>80~100</td> <td>60</td> </tr> <tr> <td>2</td> <td>150~180</td> <td>60</td> </tr> </tbody> </table> <p>MEASURE AT ROOM TEMP. AFTER COOLING FOR CLASS I : 24 ± 2 HOURS CLASS II : 48 ± 4 HOURS</p>	STEP	TEMP.($^\circ\text{C}$)	TIME (SEC.)	1	80~100	60	2	150~180	60
STEP	TEMP.($^\circ\text{C}$)	TIME (SEC.)										
1	80~100	60										
2	150~180	60										

Multilayer Ceramic Capacitor - High Voltage

NO	ITEM	PERFORMANCE	TEST CONDITION	
12	VIBRATION TEST	APPEARANCE	NO MECHANICAL DAMAGE SHALL OCCUR.	
		CAPACITANCE	CHARACTERISTIC	CAP. CHANGE
			CLASS I	WITHIN $\pm 2.5\%$ OR $\pm 0.25\text{pF}$ WHICHEVER IS LARGER
			CLASS II	WITHIN $\pm 5\%$
		Q CLASS I	30pF AND OVER : $Q \geq 1000$ LESS THAN 30pF : $Q \geq 400+20 \times C$	THE CAPACITOR SHALL BE SUBJECTED TO A HARMONIC MOTION HAVING A TOTAL AMPLITUDE OF 1.5mm. THE ENTIRE FREQUENCY RANGE, FROM 10 TO 55Hz AND RETURN TO 10Hz, SHALL BE TRAVERSED IN 1 MINUTE. THIS CYCLE SHALL BE PERFORMED 2 HOURS IN EACH THERE MUTUALLY PERPENDICULAR DIRECTION, FOR TOTAL PERIOD OF 6 HOURS.
		Tan δ CLASS II	TO SATISFY THE SPECIFIED INITIAL VALUE	
INSULATION RESISTANCE	TO SATISFY THE SPECIFIED INITIAL VALUE			
13	HUMIDITY (STEADY STATE)	APPEARANCE	NO MECHANICAL DAMAGE SHALL OCCUR	
		CAPACITANCE	CHARACTERISTIC	CAPACITANCE CHANGE
			CLASS I	WITHIN $\pm 5\%$ OR $\pm 0.5\text{pF}$ WHICHEVER IS LARGER
			CLASS II	WITHIN $\pm 12.5\%$
		Q CLASS I	30pF AND OVER : $Q \geq 350$ 10 ~30pF : $Q \geq 275 + 2.5 \times C$ LESS THAN 10pF : $Q \geq 200 + 10 \times C$	TEMPERATURE : $40 \pm 2 \text{ }^\circ\text{C}$ RELATIVE HUMIDITY : 90~95 %RH TEST TIME : 500 +12/-0 Hr. MEASURE AT ROOM TEMPERATURE AFTER COOLING FOR CLASS I : 24 \pm 2 Hr. CLASS II : 48 \pm 4 Hr.
		Tan δ CLASS II	B : 5% MAX (0.05 MAX) C : 0.1 MAX (0.001 MAX)	
INSULATION RESISTANCE	MINIMUM INSULATION RESISTANCE: 1,000 M Ω OR 50M $\Omega \cdot \mu\text{F}$ PRODUCT WHICHEVER IS SMALLER			

* THE INITIAL VALUE OF HIGH DIELECTRIC CONSTANT SERIES SHALL BE MEASURED AFTER THE HEAT TREATMENT OF 150 +0/-10 $^\circ\text{C}$, 1hr AND SITTING OF 48 \pm 4hr AT ROOM TEMPERATURE & ROOM HUMIDITY.

Multilayer Ceramic Capacitor - High Voltage

NO	ITEM	PERFORMANCE	TEST CONDITION		
14	MOISTURE RESISTANCE	APPEARANCE	NO MECHANICAL DAMAGE SHALL OCCUR	1KV TO 3KV PRODUCTS ARE NOT APPLIED TO THIS TEST WITHOUT COATING THE TESTED SAMPLES WITH EPOXY FOR INSULATION APPLIED VOLTAGE : RATED VOLTAGE TEMPERATURE : 40±2 °C RELATIVE HUMIDITY:90~95%RH TEST TIME : 500 +12/-0 Hr. CURRENT APPLIED : 50mA MAX.	
		CAPACITANCE	CHARACTERIST IC		CAPACITANCE CHANGE
			CLASS I		WITHIN ±7.5% OR ±0.75pF WHICHEVER IS LARGER
			CLASS II		WITHIN ±12.5%
		Q CLASS I	30pF AND OVER : Q ≥ 200 30pF AND BELOW : Q ≥ 100 + 10/3×C		
		Tanδ CLASS II	B : 5% MAX (0.05 MAX) C : 0.1 MAX (0.001 MAX)		
		INSULATION RESISTANCE	MINIMUM INSULATION RESISTANCE: 500 MΩ OR 25MΩ·μF PRODUCT, WHICHEVER IS SMALLER.		<INITIAL MEASUREMENT> CLASS II SHOULD BE MEASURED INITIAL VALUE AFTER BE HEAT-TREATED FOR 1 HR IN 150°C +0/-10°C AND BE LEFT FOR 48±4HR AT ROOM TEMPERATURE. <LATTER MEASUREMENT> CLASS I SHOULD BE MEASURED AFTER LEFT FOR 24±2 HRS IN ROOM TEMPERATURE AND HUMIDITY. CLASS II SHOULD BE MEASURED LATTER VALUE AFTER BE HEAT-TREATED FOR 1 HR IN 150°C +0/-10°C AND BE LEFT FOR 48±4HR AT ROOM TEMPERATURE.
15	HIGH TEMPERATURE RESISTANCE	APPEARANCE	NO MECHANICAL DAMAGE SHALL OCCUR	APPLIED VOLTAGE : for Vr<500Vdc,200% OF Vr for 500Vdc≤Vr<1000Vdc,120% OF Vr for 1000Vdc≤Vr, Vr TEST TIME : 1000 +48/-0 Hr. CURRENT APPLIED : 50mA MAX. TEMP: MAX OPERATING TEMP±2°C <INITIAL MEASUREMENT> CLASS II SHOULD BE MEASURED INITIAL VALUE AFTER BE HEAT-TREATED FOR 1 HR IN 150°C +0/-10°C AND BE LEFT FOR 48±4HR AT ROOM TEMPERATURE. <LATTER MEASUREMENT> CLASS I SHOULD BE MEASURED AFTER LEFT FOR 24±2 HRS IN ROOM TEMPERATURE AND HUMIDITY. CLASS II SHOULD BE MEASURED LATTER VALUE AFTER BE HEAT-TREATED FOR 1 HR IN 150°C +0/-10°C AND BE LEFT FOR 48±4HR AT ROOM TEMPERATURE.	
		CAPACITANCE	CHARACTERIST IC		CAP. CHANGE
			CLASS I		WITHIN ±3% OR ±0.3pF, WHICHEVER IS LARGER
			CLASS II		WITHIN ±12.5%
		Q CLASS I	30pF AND OVER : Q ≥ 350 10 ~ 30 pF : Q ≥ 275 + 2.5×C LESS THAN 10pF :Q ≥200 + 10×C		
		Tanδ CLASS II	B : 5% MAX (0.05 MAX) C : 0.1% MAX (0.001 MAX)		
		INSULATION RESISTANCE	MINIMUM INSULATION RESISTANCE: 1,000 MΩ OR 50MΩ·μF PRODUCT WHICHEVER IS SMALLER		

Multilayer Ceramic Capacitor - High Voltage

NO	ITEM	PERFORMANCE	TEST CONDITION															
16	APPEARANCE	NO MECHANICAL DAMAGE SHALL OCCUR	CAPACITORS SHALL BE SUBJECTED TO FIVE CYCLES OF THE TEMPERATURE CYCLE AS FOLLOWING <table border="1" style="margin-top: 10px;"> <thead> <tr> <th>STEP</th> <th>TEMP.(°C)</th> <th>TIME (MIN)</th> </tr> </thead> <tbody> <tr> <td>1</td> <td>MIN. RATED TEMP. +0/-3</td> <td>30</td> </tr> <tr> <td>2</td> <td>25</td> <td>2~3</td> </tr> <tr> <td>3</td> <td>MAX. RATED TEMP. +3/-0</td> <td>30</td> </tr> <tr> <td>4</td> <td>25</td> <td>2~3</td> </tr> </tbody> </table>	STEP	TEMP.(°C)	TIME (MIN)	1	MIN. RATED TEMP. +0/-3	30	2	25	2~3	3	MAX. RATED TEMP. +3/-0	30	4	25	2~3
	STEP	TEMP.(°C)		TIME (MIN)														
	1	MIN. RATED TEMP. +0/-3		30														
	2	25		2~3														
	3	MAX. RATED TEMP. +3/-0		30														
	4	25		2~3														
	CAPACITANCE	CHARACTERISTIC		CAP. CHANGE														
CLASS I		WITHIN $\pm 2.5\%$ OR $\pm 0.25 \mu\text{F}$ WHICHEVER IS LARGER																
CLASS II		WITHIN $\pm 7.5\%$																
Q CLASS I	30 μF AND OVER : $Q \geq 1000$ LESS THAN 30 μF : $Q \geq 400 + 20 \times C$																	
Tan δ CLASS II	TO SATISFY THE SPECIFIED INITIAL VALUE																	
INSULATION RESISTANCE	TO SATISFY THE SPECIFIED INITIAL VALUE	MEASURE AT ROOM TEMPERATURE AFTER COOLING FOR CLASS I : 24 \pm 2 Hr. CLASS II : 48 \pm 4 Hr.																

Multilayer Ceramic Capacitor - High Voltage

CHARACTERISTIC GRAPH

ELECTRICAL CHARACTERISTICS

CAPACITANCE - TEMPERATURE CHARACTERISTICS

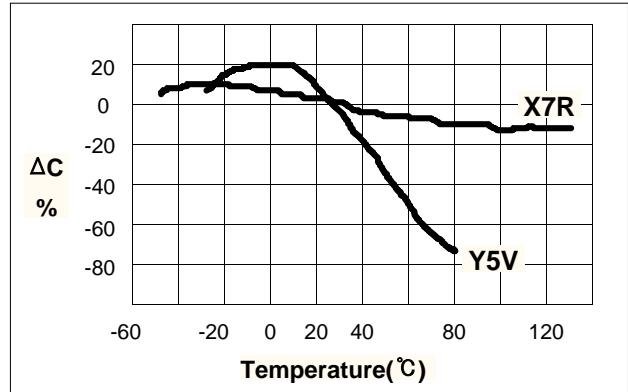
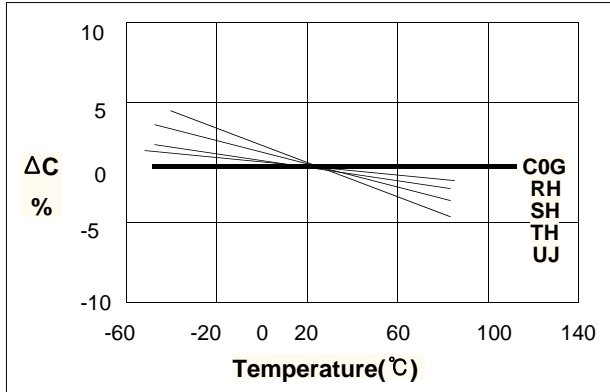

CAPACITANCE - DC VOLTAGE CHARACTERISTICS

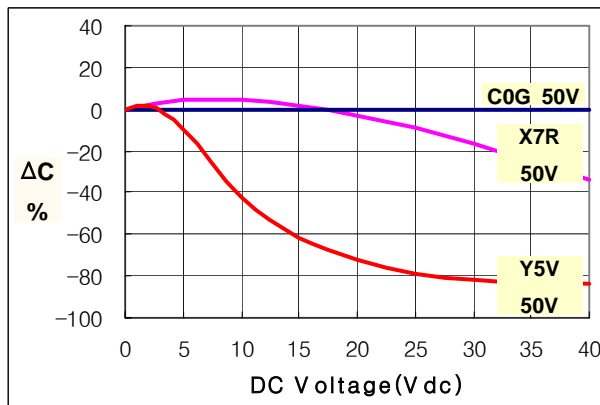

CAPACITANCE CHANGE - AGING

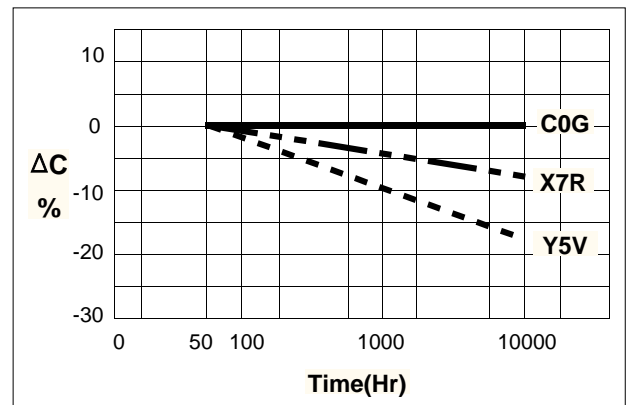

IMPEDANCE - FREQUENCY CHARACTERISTICS

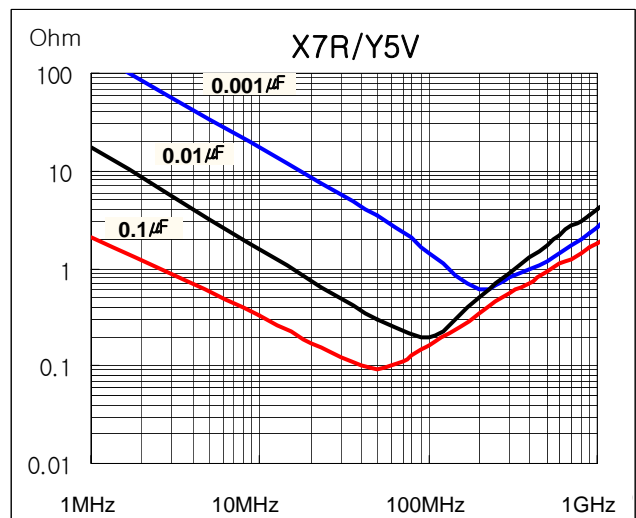
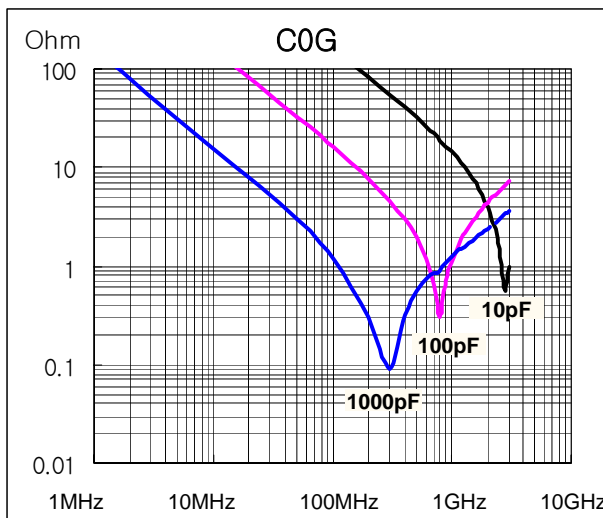

Multilayer Ceramic Capacitor - High Voltage

■ APPLICATION MANUAL

● Storage Condition

▶ Storage Environment

The electrical characteristics of MLCCs were degraded by the environment of high temperature or humidity. Therefore, the MLCCs shall be stored in the ambient temperature and the relative humidity of less than 40°C and 70%, respectively. Guaranteed storage period is within 6 months from the outgoing date of delivery.

▶ Corrosive Gases

Since the solderability of the end termination in MLCC was degraded by a chemical atmosphere such as chlorine, acid or sulfide gases, MLCCs must be avoid from these gases.

▶ Temperature Fluctuations

Since dew condensation may occur by the differences in temperature when the MLCCs are taken out of storage, it is important to maintain the temperature-controlled environment.

● Design of Land Pattern

When designing printed circuit boards, the shape and size of the lands must allow for the proper amount of solder on the capacitor. The amount of solder at the end terminations has a direct effect on the crack. The crack in MLCC will be easily occurred by the tensile stress which was due to too much amount of solder. In contrast, if too little solder is applied, the termination strength will be insufficiently. Use the following illustrations as guidelines for proper land design.

Recommendation of Land Shape and Size

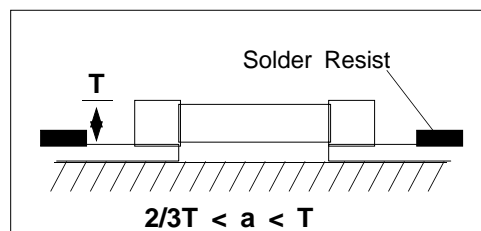
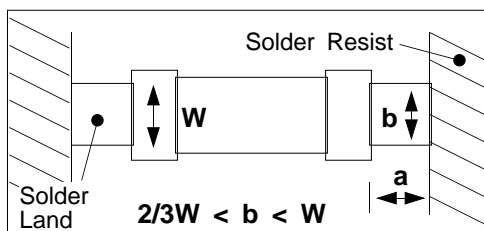

● Adhesives

When flow soldering the MLCCs, apply the adhesive in accordance with the following conditions.

▶ Requirements for Adhesives

They must have enough adhesion, so that, the chips will not fall off or move during the handling of the circuit board.

They must maintain their adhesive strength when exposed to soldering temperature.

They should not spread or run when applied to the circuit board.

They should harden quickly.

They should not corrode the circuit board or chip material.

Multilayer Ceramic Capacitor - High Voltage

They should be a good insulator.

They should be non-toxic, and not produce harmful gases, nor be harmful when touched.

▶ Application Method

It is important to use the proper amount of adhesive. Too little and much adhesive will cause poor adhesion and overflow into the land, respectively.

▶ Adhesive hardening Characteristics

To prevent oxidation of the terminations, the adhesive must harden at 160°C or less, within 2 minutes or less.

● Mounting

▶ Mounting Head Pressure

Excessive pressure will cause crack to MLCCs. The pressure of nozzle will be 300g maximum during mounting.

▶ Bending Stress

When double-sided circuit boards are used, MLCCs first are mounted and soldered onto one side of the board. When the MLCCs are mounted onto the other side, it is important to support the board as shown in the illustration. If the circuit board is not supported, the crack occur to the ready-installed MLCCs by the bending stress.

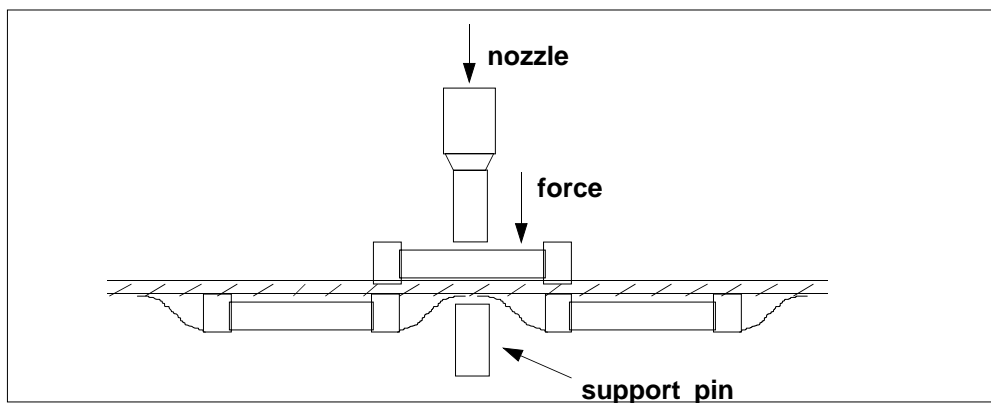

● Flux

Although the solderability increased by the highly-activated flux, increase of activity in flux may also degrade the insulation of the chip capacitors. To avoid such degradation, it is recommended that a mildly activated rosin flux (less than 0.2% chlorine) be used.

Multilayer Ceramic Capacitor - High Voltage

● Soldering

Since a multilayer ceramic chip capacitor comes into direct contact with melted solder during soldering, it is exposed to potentially mechanical stress caused by the sudden temperature change. The capacitor may also be subject to silver migration, and to contamination by the flux. Because of these factors, soldering technique is critical.

► Soldering Methods

Method	Classification	
Reflow soldering	- Overall heating	- Infrared rays - Hot plate - VPS(vapor phase)
	- Local heating	- Air heater - Laser - Light beam
Flow soldering	- Single wave - Double wave	-

* We recommend the reflow soldering method.

► Soldering Profile

To avoid crack problem by sudden temperature change, follow the temperature profile in the adjacent graph.

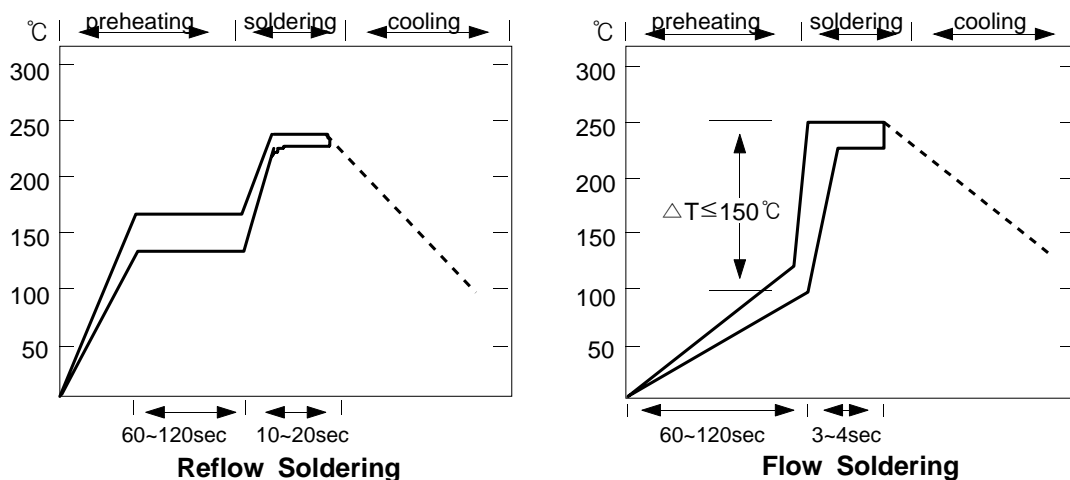

► Manual Soldering

Manual soldering can pose a great risk of creating thermal cracks in chip capacitors. The hot soldering iron tip comes into direct contact with the end terminations, and operator's carelessness may cause the tip of the soldering iron to come into direct contact with the ceramic body of the capacitor. Therefore the soldering iron must be handled carefully, and close attention must be paid to the selection of the soldering iron tip and to temperature control of the tip.

Multilayer Ceramic Capacitor - High Voltage

► Amount of Solder

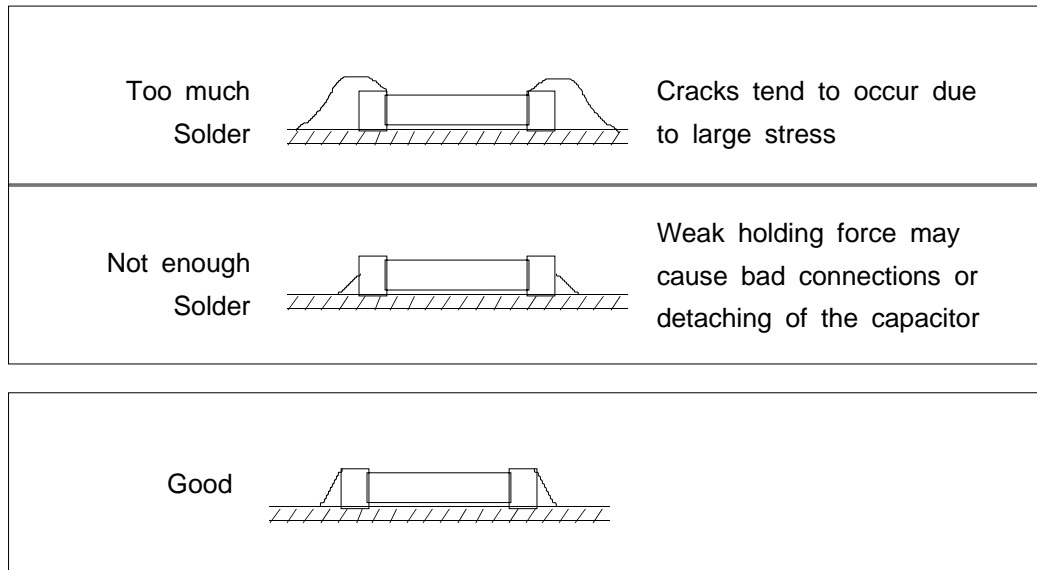

► Cooling

Natural cooling using air is recommended. If the chips are dipped into solvent for cleaning, the temperature difference (ΔT) must be less than 100°C

6-6. Cleaning

If rosin flux is used, cleaning usually is unnecessary. When strongly activated flux is used, chlorine in the flux may dissolve into some types of cleaning fluids, thereby affecting the chip capacitors. This means that the cleaning fluid must be carefully selected, and should always be new.

► Notes for Separating Multiple, Shared PC Boards.

A multi-PC board is separated into many individual circuit boards after soldering has been completed. If the board is bent or distorted at the time of separation, cracks may occur in the chip capacitors. Carefully choose a separation method that minimizes the bending of the circuit board.

Multilayer Ceramic Capacitor - High Voltage

CROSS REFERENCE

P/N	COMPANY	SAMSUNG	AVX	JOHANSON	KEMET	KYOCERA	MURATA	NOVACAP	PANASONIC	ROHM	TAIYO - YUDEN	TDK	VITRAMON
① COMPANY	MODEL(MLCC)	CL	-	-	C	CM	GRM	-	ECJ	MCH	MK	C	VJ
② SIZE (EIA/JIS)	0201(0603)	03	-	-	-	03	33	-	Z	-	063	0603	-
	0402(1005)	05	0402	R07	0402	05	36	0402	0	15	105	1005	0402
	0603(1608)	10	0603	R14	0603	105	39	0603	1	18	107	1608	0603
	0805(2012)	21	0805	R15	0805	21	40	0805	2	21	212	2012	0805
	1206(3216)	31	1206	R18	1206	316	42-6	1206	3	31	316	3216	1206
	1210(3225)	32	1210	S41	1210	32	42-2	1210	4	32	325	3225	1210
	1808(4520)	42	1808	R29	1808	42	-	1808	-	-	-	4520	1808
	1812(4532)	43	1812	S43	1812	43	43-2	1812	-	43	432	4532	1812
	2220(5750)	55	-	-	2220	55	44-1	2221	-	-	550	5650	-
③ TEMPERATURE CHARACTERISTIC	COG(NPO)	C	A	N	G	CG	COG/CH	N	C	A	C	COG/CH	A
	P2H(N150)	P	S	-	-	P	P2H	-	P	-	P	PH	-
	R2H(N220)	R	1	-	-	R	R2H	-	R	-	R	RH	-
	S2H(N330)	S	3	-	-	S	S2H	-	S	-	S	SH	-
	T2H(N470)	T	O	-	-	T	T2H	-	T	-	T	TH	-
	U2J(N750)	U	Z	-	-	U	U2J	-	U	UJ	U	UJ	-
	S2L	L	Y	-	-	SL	SL	-	G	SL	SL	SL	-
	X7R	B	C	W	R(X)	X7R	X7R	B	B	C	BJ	X7R(B)	Y(X)
	Z5U	E	E	Z	U	-	Z5U	Z	-	E	-	Z5U	U
Y5V	F	G	Y	V	Y5V	Y5V	Y	F	F	F	Y5V	-	
④ NOMINAL CAPACITANCE		EX) 103=10,000pF 221=220pF 225=2,200,000pF=2.2μF 1R5=1.5pF 010=1pF											
⑤ CAPACITANCE TOLERANCE		B:±0.1pF C:±0.25pF D:±0.5pF F:±1% G:±2% J:±5% K:±10% M:±20% Z:-20~+80%											
⑥ RATED VOLTAGE	6.3V	Q	6	-	9	06	6.3	-	0J	-	J	0J	-
	10 V	P	Z	100	8	10	10	-	1A	4	L	1A	-
	16 V	O	Y	160	4	16	16	160	1C	3	E	1C	J
	25 V	A	3	250	3	25	25	250	1E	2	T	1E	X
	50 V	B	5	500	5	50	50	500	1H	5	U	1H	A
	100 V	C	1	101	1	100	100	101	2A	1	-	2A	B
	200V	D	2	201	2	200	200	201	2D	-	-	-	C
	250V	E	V	-	-	250	250	251	-	-	-	2E	-
	500V	G	7	501	-	500	500	501	-	-	-	-	E
	630V	H	-	-	-	630	630	-	-	-	-	2J	-
	1000V	I	A	102	-	1000	1K	102	-	-	-	3A	G
	2000V	J	G	202	-	2000	2K	202	-	-	-	3D	-
3000V	K	H	302	-	3000	3K	302	-	-	-	3F	H	
4000V	-	J	-	-	4000	-	402	-	-	-	-	-	
⑦ TERMINATION	NICKEL BARRIER	N	T	V	C	A	(GRM)	N	-	(MCH)	-	-	X
	Ag/Pd	P	1	-	-	B	(GR)	P	-	(MC)	-	-	F
⑧ PACKAGE	BULK(VINYL)	B	9	(NONE)	-	B	PB	*	X	-	B	B	B
	PAPER TAPING	C	2, 4	T, R	-	T, L	PT	T	E, V, W	K, L	T	T	C, P
	PLASTIC TAPING	E	1, 3	E, U	-	H, N	PT	-	F, Y	P, Q	T	-	T, R
	BULK CASE	P	7	-	-	C	PC	-	C	C	-	-	G

Multilayer Ceramic Capacitor - High Voltage

► SAMSUNG : CL10B104KA8NNC

CL	10	B	104	K	A	8	N	N	N	C
Series	Size	Dielectric	Capacitance	Tolerance	Voltage	Thickness	Electrode/ Termination/ Plating	Products	Special	Packaging
03 = 0201 05 = 0402 10 = 0603 21 = 0805 31 = 1206 32 = 1210 43 = 1812 55 = 2220	C = C0G P = P2H R = R2H S = S2H T = T2H U = U2H L = S2L B = X7R A = X5R F = Y5V	2 significant figures + number of zeros Use "R" for decimal point	A = ±0.05pF B = ±0.1pF C = ±0.25pF D = ±0.5pF F = ±1% G = ±2% J = ±5% K = ±10% M = ±20% Z = +80,-20%	Q = 6.3V P = 10V O = 16V A = 25V B = 50V C = 100V D = 200V E = 250V G = 500V H = 630V I = 1000V	3 = 0.30 5 = 0.50 8 = 0.80 A = 0.65 C = 0.85 H = 1.60 I = 2.00 J = 2.50 L = 3.20	A = Pd/Ag/ Sn 100% N = Ni/Cu/ Sn 100% G = Cu/Cu/ Sn 100%	A = Array (2-element) B = Array (4-element) C = High - Q L = LICC N = Normal P = Automotive W = 3 terminal chip	Various	B = Bulk P = Cassette C = Paper 7" D = Paper 13" (10,000EA) E = Embossing 7" F = Embossing 13" L = Paper 13" (15,000EA) O = Paper 10" S = Embossing 10"	

► AVX : 06033C104KAT2A

0603	3	C	104	K	A	T	2	A
Size	Voltage	Dielectric	Capacitance	Tolerance	Failure Rate	Termination	Packaging	Special
0201 0402 0603 0805 1206 1210 1812 2220 2225	4 = 4V 6 = 6.3V Z = 10V Y = 16V 3 = 25V B = 50V C = 100V D = 200V E = 250V G = 500V I = 1000V	A = C0G C = X7R D = X5R E = Z5U G = Y5V	2 significant figures + number of zeros Use "R" for decimal point	B = ±0.1pF C = ±0.25pF D = ±0.5pF F = ±1% G = ±2% J = ±5% K = ±10% M = ±20% Z = +80, -20% P = GMV,+100,-0%	A = N/A	T = Sn 100% 7 = Gold Plated 1 = Pd/Ag	2 = 7" Reel 4 = 13" Reel 7 = Cassette 9 = Bulk	A = Standard T = 0.66mm S = 0.56mm R = 0.46mm

► JOHANSON : 250R14W104KV6T

250	R14	W	104	K	V	6	T
Voltage	Size	Dielectric	Capacitance	Tolerance	Termination	Marking	Packaging
2 significant figures + number of zeros	R07 = 0402 R14 = 0603 R15 = 0805 R18 = 1206 S41 = 1210 S43 = 1812 S47 = 2220 S48 = 2225 S49 = 1825 S54 = 3640	N = C0G W = X7R X = X5R Z = Z5U Y = Y5V	2 significant figures + number of zeros Use "R" for decimal point	B = ±0.1pF C = ±0.25pF D = ±0.5pF F = ±1% G = ±2% J = ±5% K = ±10% M = ±20% Z = +80, -20% P = GMV,+100,-0%	V = Ni Barrier	4 = No Mark 6 = Marking	E = 7" Reel Plastic T = 7" Reel Paper R = 13" Reel Paper U = 13" Reel Plastic None = Bulk

► KEMET : C0603C104K3RAC

C	0603	C	104	K	3	R	A	C
Series	Size	Specification	Capacitance	Tolerance	Voltage	Dielectric	Failure Rate	Termination
0402 0603 0805 1206 1210 1812 2220 2225	C = Standard A = GR900 P = Mil-C-55681 CDR01-CDR06 N = Mil-C-55681 CDR31-CDR35 Z = Mil-C-123 E = Mil Equivalent (Group A Only)	2 significant figures + number of zeros Use "R" for decimal point	B = ±0.1pF C = ±0.25pF D = ±0.5pF F = ±1% G = ±2% J = ±5% K = ±10% M = ±20% Z = +80, -20% P = +100, 0%	9 = 6.3V 8 = 10V 4 = 16V 3 = 25V 5 = 50V 1 = 100V 2 = 200V	G = C0G R = X7R P = X5R U = Z5U X = BX(Mil) V = Y5V	A = Standard M = 1.0 (Mil) P = 0.1 (Mil) R = 0.01 (Mil) S = 0.001 (Mil)	C = Ni w/Tin Plate H = Ni w/Solder T = Silver G = Gold Plated	

Multilayer Ceramic Capacitor - High Voltage

► KYOCERA : CM105X7R104K25AT

CM	105	X7R	104	K	25	A	T
Series	Size	Dielectric	Capacitance	Tolerance	Voltage	Termination	Packaging
	03 = 0201 05 = 0402 105 = 0603 21 = 0805 316 = 1206 32 = 1210 42 = 1808 43 = 1812 55 = 2220	CG X8R X7R X5R Z5U Y5V Y5U	2 significant figures + number of zeros Use "R" for decimal point	B = $\pm 0.1\text{pF}$ C = $\pm 0.25\text{pF}$ D = $\pm 0.5\text{pF}$ F = $\pm 1\%$ G = $\pm 2\%$ J = $\pm 5\%$ K = $\pm 10\%$ M = $\pm 20\%$ Z = +80, -20% P = +100, 0%	04 = 4V 06 = 6.3V 10 = 10V 16 = 16V 25 = 25V 50 = 50V 100 = 100V 250 = 250V 500 = 500V 1000 = 1000V	A = Ni Barrier	T = 7" Reel (4mm Pitch) L = 13" Reel (4mm Pitch) H = 7" Reel (2mm Pitch) N = 13" Reel (2mm Pitch) B = Bulk (Vinyl Bags) C = Bulk Cassette

► MURATA : GRM188R71E104KA01D

GRM	18	8	R7	1E	104	K	A01	D
Series	Size	Thickness	Dielectric	Voltage	Capacitance	Tolerance	Individual Specification Code	Packaging
Ni Barrier	03 = 0201 15 = 0402 18 = 0603 21 = 0805 31 = 1206 32 = 1210 42 = 1808 43 = 1812 55 = 2220	3 = 0.3mm 5 = 0.5mm 8 = 0.8mm A = 1.0mm B = 1.25mm C = 1.6mm D = 2.0mm E = 2.5mm F = 3.2mm	5C = C0G R7 = X7R R6 = X5R E4 = Z5U F5 = Y5V	0J = 6.3V 1A = 10V 1C = 16V 1E = 25V 1H = 50V 2A = 100V 2E = 250V 2H = 500V 3A = 1000V	2 significant figures + number of zeros Use "R" for decimal point	B = $\pm 0.1\text{pF}$ C = $\pm 0.25\text{pF}$ D = $\pm 0.5\text{pF}$ F = $\pm 1\%$ G = $\pm 2\%$ J = $\pm 5\%$ K = $\pm 10\%$ M = $\pm 20\%$ Z = +80,-20% P = +100, 0%		D = 7" Reel Paper L = 7" Reel Plastic J = 13" Reel Paper K = 13" Reel Plastic B = Bulk C = Bulk Cassette T = Bulk Tray

► NOVACAP : 0603B104K250N_TM

1206	B	104	K	250	N	-	T	M
Size	Dielectric	Capacitance	Tolerance	Voltage	Termination	Thickness	Packaging	Marking
0402 0603 0805 1005 1206 1210 1808 1812 2220	N = C0G B = X7R X = BX Z = Z5U Y = Y5V	2 significant figures + number of zeros Use "R" for decimal point	B = $\pm 0.1\text{pF}$ C = $\pm 0.25\text{pF}$ D = $\pm 0.5\text{pF}$ F = $\pm 1\%$ G = $\pm 2\%$ J = $\pm 5\%$ K = $\pm 10\%$ M = $\pm 20\%$ Z = +80,-20% P = +100, 0%	2 significant figures + number of zeros	P = Pd/Ag N = Ni Barrier (Sn 100%) Y = Ni Barrier (Sn/Pb)	Per Specified	T = Reel None = Bulk W = Waffle Pack	

► PANASONIC : ECJ1EB1E104K

ECJ	1	E	B	1E	104	K
Series	Size	Packaging	Dielectric	Voltage	Capacitance	Tolerance
	Z = 0201 0 = 0402 1 = 0603 2 = 0805 3 = 1206 4 = 1210	X = Bulk E = Paper 2mm V = Paper 4mm F, Y = Plastic 4mm W = Large Reels 2mm Z = Large Reels 4mm C = Bulk Cassette	C = C0G B = X7R, X5R F = Y5V	0J = 6.3V 1A = 10V 1C = 16V 1E = 25V 1H = 50V 2A = 100V 2D = 200V	2 significant figures + number of zeros Use "R" for decimal point	C = $\pm 0.25\text{pF}$ D = $\pm 0.5\text{pF}$ F = $\pm 1\%$ J = $\pm 5\%$ K = $\pm 10\%$ M = $\pm 20\%$ Z = +80, -20%

Multilayer Ceramic Capacitor - High Voltage

▶ ROHM : MCH182C104KKN

MCH	18	2	C	104	K	K	N
Series	Size	Voltage e	Dielectric	Capacitance	Tolerance	Packaging	Marking/Thickness
	15 = 0402 18 = 0603 21 = 0805 31 = 1206 32 = 1210 43 = 1812	4 = 10V 3 = 16V 2 = 25V 5 = 50V	A = C0G C = X7R F = Y5V	2 significant figures + number of zeros Use "R" for decimal point	B = ±0.1pF C = ±0.25pF D = ±0.5pF F = ±1% G = ±2% J = ±5% K = ±10% M = ±20% Z = +80,-20% P = +100, 0%	K = 7" Reel Paper P = 7" Reel Plastic L = 13" Reel Paper Q = 13" Reel Plastic B = Bulk C = Bulk Cassette	N = Marked Special Thickness

▶ TAIYO-YUDEN : TMK107BJ104K_T

T	M	K	107	BJ	104	K	-	T
Voltage	Type	Termination	Size	Dielectric	Capacitance	Tolerance	Special	Packaging
A = 4V J = 6.3V L = 10V E = 16V T = 25V U = 50V	M = Multilayer V = Hi Q	K = Ni Barrier	105 = 0402 107 = 0603 212 = 0805 316 = 1206 325 = 1210 432 = 1812 550 = 2220	CG = C0G CH = C0H CJ = C0J CK = C0K BJ = X5R, X7R F = Y5V	2 significant figures + number of zeros Use "R" for decimal point	C = ±0.25pF D = ±0.5pF F = ±1% G = ±2% J = ±5% K = ±10% M = ±20% Z = +80,-20%	Various	T = Reel B = Bulk

▶ TDK : C1608X7R1E104KT

C	1608	X7R	1E	104	K	T
Series	Size	Dielectric	Voltage	Capacitance	Tolerance	Packaging
	0603 = 0201 1005 = 0402 1608 = 0603 2012 = 0805 3216 = 1206 3225 = 1210 4532 = 1812 5650 = 2220	CG X7R Z5U Y5V	0J = 6.3V 1A = 10V 1C = 16V 1E = 25V 1H = 50V	2 significant figures + number of zeros Use "R" for decimal point	C = ±0.25pF D = ±0.5pF F = ±1% G = ±2% J = ±5% K = ±10% M = ±20% Z = +80, -20%	T = Reel B = Bulk

▶ VITRAMON : VJ0603Y104KXXMC

VJ	0603	Y	104	K	X	X	M	C
Series	Size	Dielectric	Capacitance	Tolerance	Termination	Voltage	Marking	Packaging
	0402 0603 0805 1206 1210 1812 2225	X = BX A,N = C0G Y = X7R U = Z5U H = X8R	2 significant figures + number of zeros Use "R" for decimal point	B = ±0.1pF C = ±0.25pF D = ±0.5pF F = ±1% G = ±2% J = ±5% K = ±10% M = ±20% Z = +80, -20% P = +100, 0%	X = Silver, Ni Barrier Tin Plated	J = 16V X = 25V A = 50V B = 100V C = 200V	M = Marking A = No Marking	C = 7" Reel Paper T = 7" Reel Plastic P = 13" Reel Paper R = 13" Reel Plastic B = Bulk