

AC Filter 2-Stage, Very High Symmetrical Attenuation



**Description**

- Chassis:  
Screw-on mounting, from top
- Line-filter in standard version, 2 positions, very high attenuation, broad-band
- Especially effective against symmetrical interferences in the frequency range from 10kHz up to 30MHz

**Approvals**

- VDE Certificate Number: 40004673
- UL File Number: E72928

**Characteristics**

- Designed for increased requirements
- 2-stage line filter with increased attenuation  
Protection against interference voltage from the mains  
Possible interferences generated in the equipment are strongly attenuated
- Especially suitable for use in switching power supplies  
e.g. in electronic designs with high repetitive switching frequency
- Suitable for use in equipment according to IEC/UL 60950

**References**

Alternative: Standard version

**Weblinks**

[pdf-datasheet](#), [html-datasheet](#), [General Product Information](#), [Approvals](#), [CE declaration of conformity](#), [RoHS](#), [CHINA-RoHS](#), [e-Shop](#), [SCHURTER-Stock-Check](#), [Distributor-Stock-Check](#), [Detailed request for product](#)

**Technical Data**

Ratings IEC	1 - 16A @ Ta 40 °C / 250 VAC; 50Hz
Ratings UL/CSA	1 - 16A @ Ta 40 °C / 125 VAC; 60Hz
Leakage Current	industrial < 1.4 mA (250V / 60Hz)
Dielectric Strength	> 1.7 kVDC between L-N > 2.7 kVDC between L/N-PE Test voltage (2 sec)
Allowable Operation Temp.	-25 °C to 100 °C
Climatic Category	25/100/21 acc. to IEC 60068-1
Protection Class	Suitable for appliances with protection class I acc. to IEC 61140
Terminal	Quick connect terminals 6.3 x 0.8 mm or screw terminals
Material: Housing	Aluminum

Line Filter	Standard and Industrial Version, IEC 60939, UL 1283, CSA C22.2 no. 8 <a href="#">Technical Details</a>
MTBF	> 200'000h acc. to MIL-HB-217 F

**Dimension**

Case 10

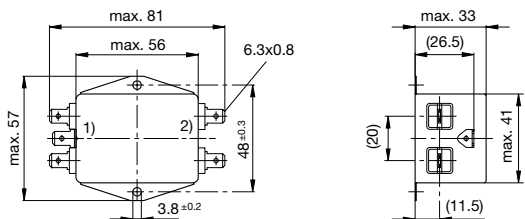

Case 19

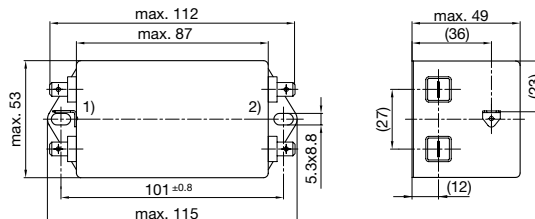

1) Line  
2) Load

1) Line  
2) Load

Case 27

Case 48

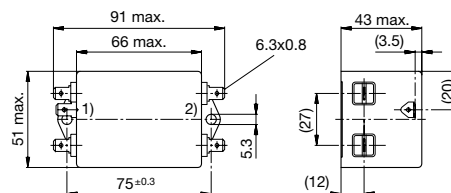
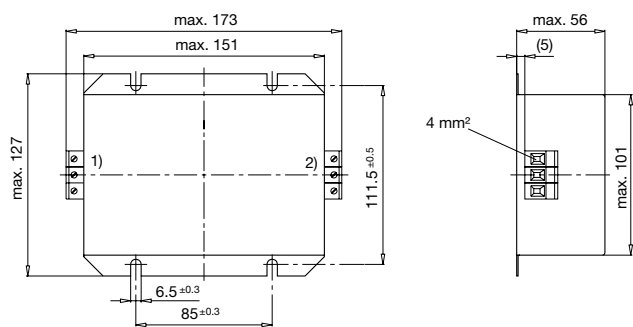

1) Line  
2) Load

1) Line  
2) Load

**Diagrams**

Standard version

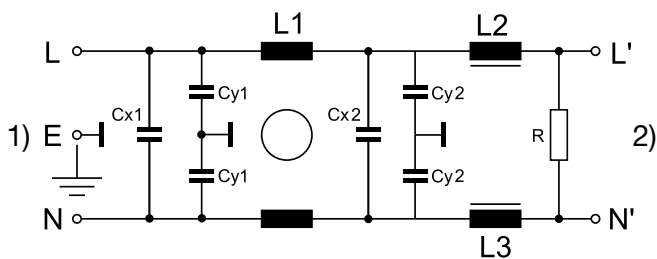

1) Line  
2) Load

**Attenuation Loss**

---- differential mode    \_\_\_\_ common mode

Standard version

1 A

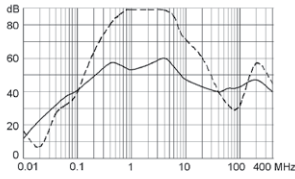

2 A

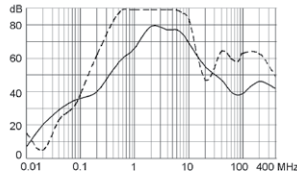

3 A

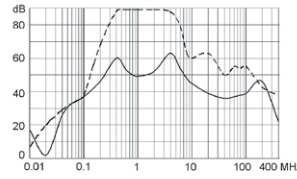

Industrial version

4 A

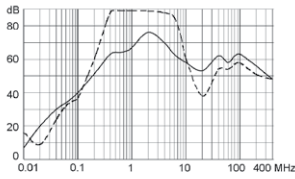

6 A

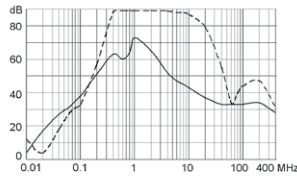

10 A

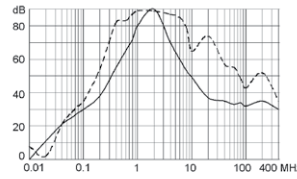

16 A

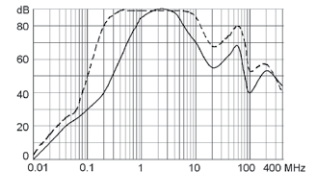

Rated Current [A]	Filter-Type	Leakage Current [mA]	L1 [mH]	L2 [mH]	L3 [mH]	Cx1 [µF]	Cx2 [µF]	Cy1 [nF]	Cy2 [nF]	R [MΩ]	Weight [g]	Housing	Order Number
1	Standard Version	0.25	2 x 15	1	-	0.1	0.47	1.5	1	1	121 g	10	5500.2051
2	Standard Version	0.25	2 x 10	0.4	0.4	0.1	0.47	1.5	1	1	121 g	10	5500.2052
3	Standard Version	0.25	2 x 12	1	-	0.1	0.68	1.5	1	1	275 g	48	5500.2053
4	Industrial Version	1.4	2 x 10	0.8	-	0.1	0.68	10	4.7	1	275 g	48	5500.2054
6	Industrial Version	1.4	2 x 6	0.5	-	0.1	0.68	10	4.7	1	284 g	48	5500.2055
10	Industrial Version	1.4	2 x 5	0.2	0.2	0.1	1	10	4.7	1	529 g	19	5500.2056
16	Industrial Version	1.4	2 x 4	0.2	0.2	0.47	2.2	10	4.7	1	2000 g	27	5500.2057

Most Popular.

Availability for all products can be searched real-time: <http://www.schurter.com/en/Stock-Check/Stock-Check-SCHURTER>

**Packaging unit**    10 Pcs