

- **Precise Proportional Load Control**
- **Optically Isolated**
- **0-5 Vdc, 0-10 Vdc, 4-20mA Input Control Models**
- **Control Circuit Requires no Adjustment or Calibration**

The LPCV Linear Proportional Controllers control loads up to 110 Amps. Changes in the input signal linearly vary the firing angle of the thyristor load control device. Control circuitry and power switch are in the same package. The PS-120 (120V) and PS-240 (240V) power supplies are designed for use with the LPCV controller to provide the 20Vac required in addition to the control voltage.

MODEL NUMBERS	0-5 Vdc CONTROL	5LPCV2415	5LPCV2425	5LPCV2440	5LPCV2475	5LPCV24110
	0-10 Vdc CONTROL	10LPCV2415	10LPCV2425	10LPCV2440	10LPCV2475	10LPCV24110
	4-20 mA CONTROL	20LPCV2415	20LPCV2425	20LPCV2440	20LPCV2475	20LPCV24110

OUTPUT SPECIFICATIONS

	5LPCV2415	5LPCV2425	5LPCV2440	5LPCV2475	5LPCV24110
Operating Voltage (60 Hz) [Vrms]	20-300	20-300	20-300	20-300	20-300
Load Current Range [Arms]	.10-15	.10-25	.10-40	.15-75	.20-110
Transient Overvoltage [Vpk]	600	600	600	600	600
Max. Surge Current, (16.6ms) [Apk]	150	250	625	1000	1500
Max. Off-State Leakage Current @ Rated Voltage [mArms]	10	15	20	30	50
Thermal Resistance Junction to Case (R _{θJC}) [°C/W]	1.4	1.02	0.63	0.31	0.28
Maximum I ² t for Fusing, (8.3 msec.) [A ² sec]	94	260	1620	4150	9340
Maximum Voltage Drop (100% On) [Vpk]	1.6	1.6	1.6	1.6	1.6
Minimum Off-State dv/dt [V/μsec]	200	200	200	200	200
Power Factor (Min.) with Max. Load	0.5	0.5	0.5	0.5	0.5

INPUT SPECIFICATIONS

	0-5 Vdc	0-10 Vdc	4-20 mA
Control Range (Nominal)	0-5 Vdc	0-10 Vdc	4-20 mA
Control Range Limits (Min/Msx)	-0.5/10 Vdc	-1.0/20 Vdc	-0.5/25 mA
Turn-On Threshold	.25 Vdc	0.5 Vdc	4.5 mA
Min. Input Impedance	12.7K Ohms	25K Ohms	460 Ohms

GENERAL NOTES

© 2007 CRYDOM Inc., Specifications subject to change without notice.

- ① All parameters at 25°C unless otherwise specified.
- ② Linear taper potentiometer 1-10K Ohm, 1/2 Watt.
- ③ 50Hz models available.
- ④ 20Vac must be in phase with load.

TYPICAL APPLICATIONS

- Infrared and Quartz Heaters
- Resistive Heating Elements
- Transformers
- Rectified DC Motors
- Thermal Forming Equipment
- Blow Molding Equipment
- Industrial Temperature Controllers
- Conveyor Speed Control
- Printing Applications

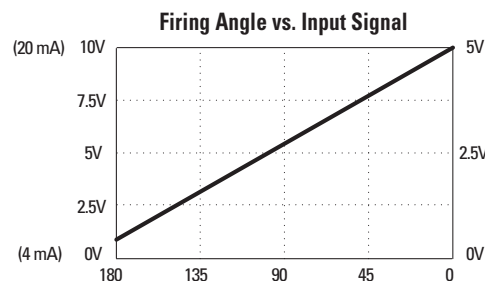

For recommended applications and more information contact:

USA: Sales Support (877) 502-5500 **Tech Support** (877) 702-7700 FAX (619) 710-8540

Crydom Inc., 2320 Paseo de las Americas, Ste. 201, San Diego, CA 92154

Email: sales@crydom.com **WEB SITE:** http://www.crydom.com

UK: +44 (0)1202 606030 • **FAX** +44 (0)1202 606035 Crydom SSR Ltd., Arena Business Centre, Holyrood Close, Poole, Dorset BH17 7FJ, Email: intsales@crydom.com.

GERMANY: +49 (0)180 3000 506

GENERAL SPECIFICATIONS

Dielectric Strength, Signal to Load	2500 Vrms
Dielectric Strength, Signal to Base	2500 Vrms
Ambient Operating Temperature Range	-30 to 80°C
Ambient Storage Temperature Range	-40 to 125°C

MECHANICAL SPECIFICATIONS

Weight: (typical)	6.0 oz. (175g)
Encapsulation:	Thermally Conductive Epoxy
Terminals:	8-32 Screws, .25 Inch Fastons

All dimensions are in inches (millimeters)

Screw Torque Requirements:
 6-32 Screws - 10 in./lbs. (1.1 Nm),
 8-32 and 10-32 Screws - 20in./lbs. (2.2 Nm)
 (Screws dry without grease.)

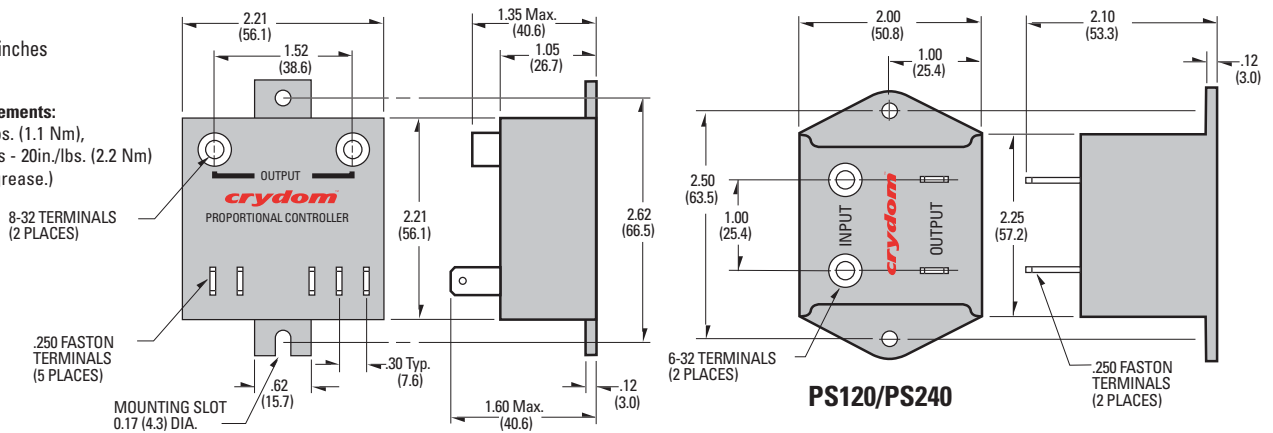

WIRING DIAGRAM

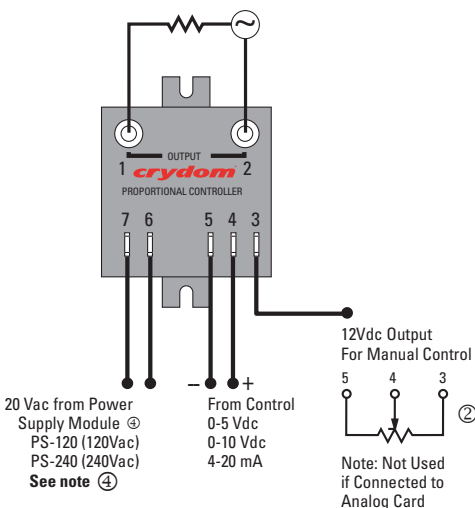

POWER SUPPLY SPECIFICATIONS ④

	PS120	PS240
Input Voltage 50/60Hz	120 Vac	240 Vac
Output Voltage 50/60Hz	20 Vac/100mA	20 Vac/100mA
Ambient Operating Temperature Range	-30 to 80°C	
Ambient Storage Temperature Range	-40 to 125°C	

MECHANICAL SPECIFICATIONS

Weight: (typical)	8.6 oz. (245g)
Encapsulation:	Thermally Conductive Epoxy
Terminals:	6-32 Screws, .25 Inch Fastons

© 2007 CRYDOM Inc., Specifications subject to change without notice.

NOTE: UNSUITABLE APPLICATIONS

The LPCV is not suitable for some load control applications including, but not limited to the following:

- AC Motor Control
- Three Phase Motors
- Transformers requiring pure sine wave input
- Applications which cannot withstand thyristor noise
- Zero Crossing Applications

Please contact Crydom's application engineering department for additional information and specific application questions.

For recommended applications and more information contact:

USA: Sales Support (877) 502-5500 Tech Support (877) 702-7700 FAX (619) 710-8540

Crydom Inc., 2320 Paseo de las Americas, Ste. 201, San Diego, CA 92154

Email: sales@crydom.com WEB SITE: <http://www.crydom.com>

UK: +44 (0)1202 606030 • FAX +44 (0)1202 606035 Crydom SSR Ltd., Arena Business Centre,

Holyrood Close, Poole, Dorset BH17 7FJ, Email: intsales@crydom.com.

GERMANY: +49 (0)180 3000 506

CURRENT DERATING CURVES

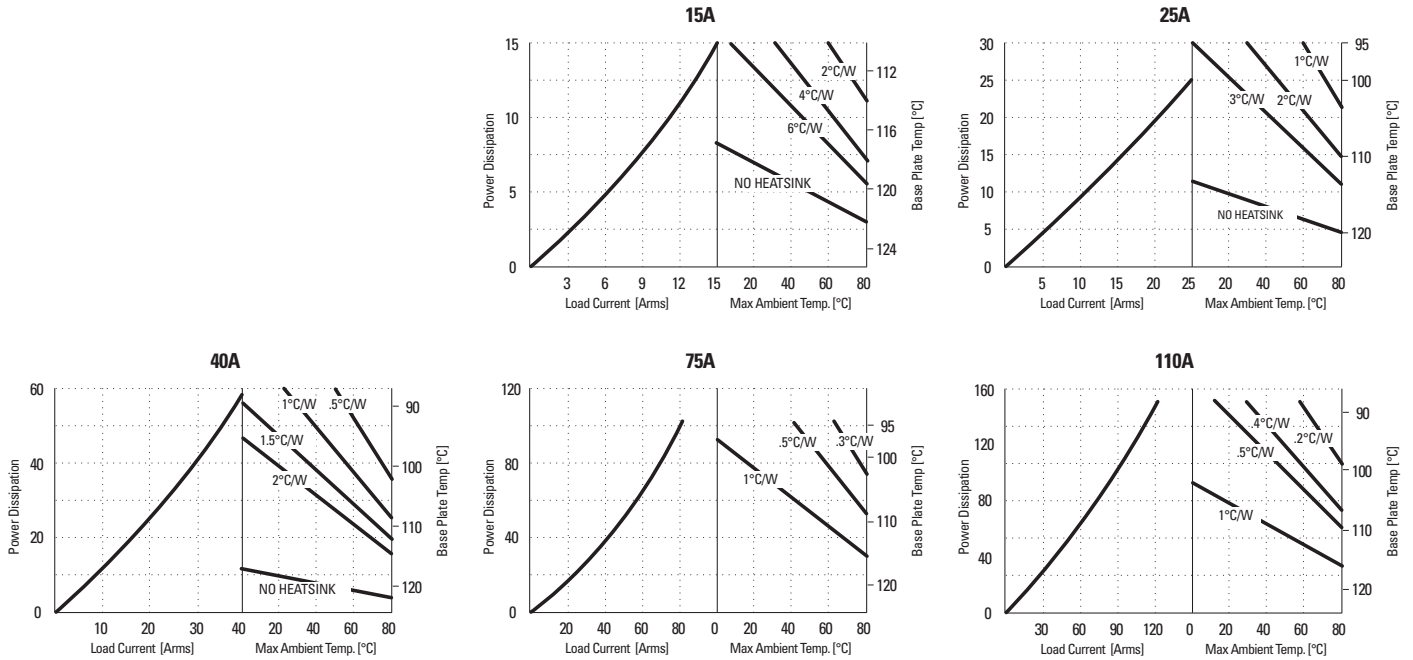

PERCENTAGE ON vs. INPUT VOLTAGE

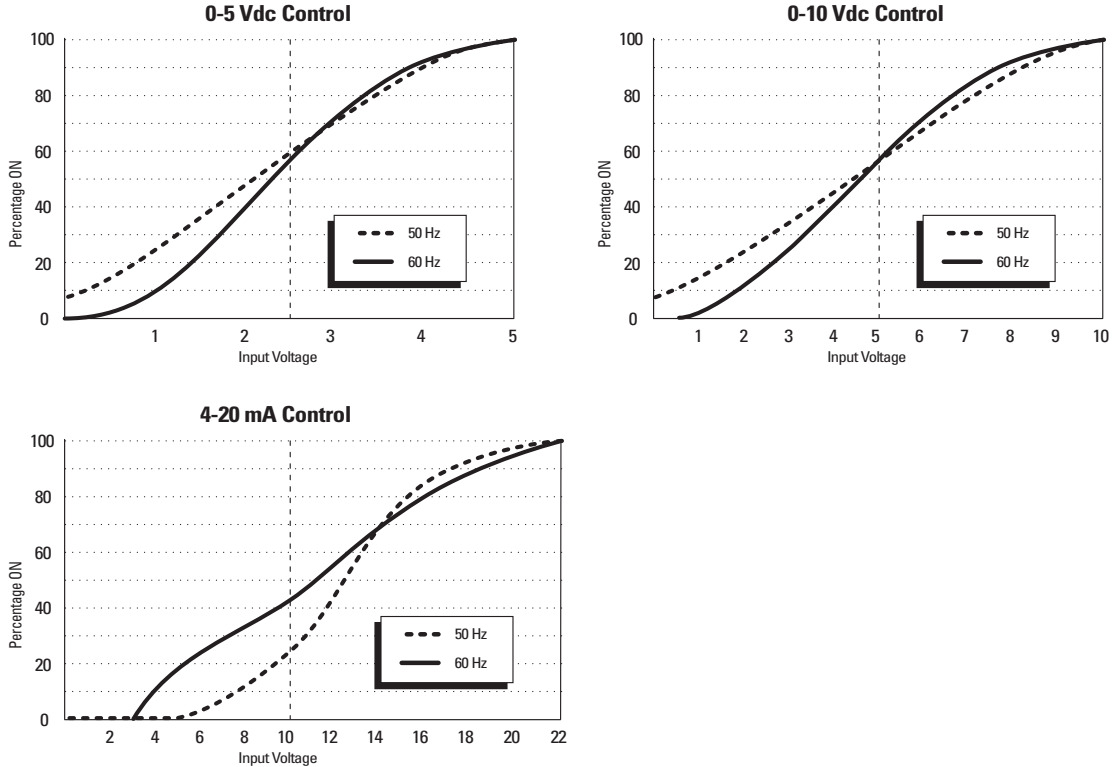

© 2007 CRYDOM Inc., Specifications subject to change without notice.

For recommended applications and more information contact:
USA: Sales Support (877) 502-5500 **Tech Support** (877) 702-7700 FAX (619) 710-8540
 Crydom Inc., 2320 Paseo de las Americas, Ste. 201, San Diego, CA 92154
Email: sales@crydom.com **WEB SITE:** http://www.crydom.com
UK: +44 (0)1202 606030 • **FAX** +44 (0)1202 606035 Crydom SSR Ltd., Arena Business Centre,
 Holyrood Close, Poole, Dorset BH17 7FJ, Email: intsales@crydom.com.
GERMANY: +49 (0)180 3000 506

**DANGER / PELIGRO / DANGER /GEFAHR / PERICOLO / PERIGO**

<p>HAZARD OF ELECTRIC SHOCK, EXPLOSION, OR ARC FLASH.</p> <ul style="list-style-type: none"> • Disconnect all power before installing or working with this equipment. • Verify all connections and replace all covers before turning on power. <p>Failure to follow these instructions will result in death or serious injury.</p>	<p>RIESGO DE DESCARGA ELECTRICA O EXPLOSION.</p> <ul style="list-style-type: none"> • Desconectar todos los suministros de energia a este equipo antes de trabajar con este equipo. • Verificar todas las conexiones y colocar todas las tapas antes de energizar el equipo. <p>El incumplimiento de estas instrucciones puede provocar la muerte o lesiones serias.</p>	<p>RISQUE DE DESCARGE ELECTRIQUE OU EXPLOSION</p> <ul style="list-style-type: none"> • Eteindre toutes les sources d'énergie de cet appareil avant de travailler dessus de cet appareil • Vérifier tous connections, et remettre tous couverts en place avant de mettre sous <p>De non-suivi de ces instructions provoquera la mort ou des lésions sérieuses.</p>	<p>GEFAHR EINES ELEKTRISCHE N SCHLAGES ODER EINER EXPLOSION.</p> <ul style="list-style-type: none"> • Stellen Sie jeglichen Strom ab, der dieses Gerät versorgt, bevor Sie an dem Gerät Arbeiten durchführen • Vor dem Drehen auf Energie alle Anschlüsse überprüfen und alle Abdeckungen ersetzen. <p>Unterlassung dieser Anweisungen können zum Tode oder zu schweren Verletzungen führen.</p>	<p>RISCHIO DI SCOSSA ELETTRICA O DELL'ESPLOSIONE.</p> <ul style="list-style-type: none"> • Spenga tutta l'alimentazione e che fornisce questa apparecchiatura prima del lavorare a questa apparecchiatura • Verificare tutti i collegamenti e sostituire tutte le coperture prima della rotazione sull'alimentazione <p>L'omissione di seguire queste istruzioni provocherà la morte o di lesioni serie</p>	<p>RISCO DE DESCARGA ELÉTRICA OU EXPLOÇÃO</p> <ul style="list-style-type: none"> • Desconectar o equipamento de toda a energia antes de instalar ou trabalhar com este equipamento • Verificar todas as conexões e recolocar todas as tampas antes de religar o equipamento <p>O não cumprimento destas instruções pode levar a morte ou lesões sérias.</p>
--	--	---	--	---	---

**WARNING / AVERTISSEMENT / WARNUNG /ADVERTENCIA / AVVERTENZA / AVISO**

<p>RISK OF MATERIAL DAMAGE AND HOT ENCLOSURE</p> <ul style="list-style-type: none"> • The product's side panels may be hot, allow time for product to cool before touching. • Follow proper mounting instructions including torque values. • Do not allow liquids or foreign objects to enter this product. <p>Failure to follow this instruction can result in serious injury, or equipment damage.</p>	<p>RISQUE DE DOMMAGE MATERIEL ET DE SURCHAUFFE DU BOITIER</p> <ul style="list-style-type: none"> • Les panneaux latéraux du produit peuvent être chauds. Laisser le produit refroidir avant de le toucher. • Respecter les consignes de montage, et notamment les couples de serrage. • Ne pas laisser pénétrer de liquide ni de corps étrangers à l'intérieur du produit. <p>Le non-respect de cette directive peut entraîner, des lésions corporelles graves ou des dommages matériels.</p>	<p>GEFAHR VON MATERIALSCHÄDEN UND GEHÄUSEERHITZUNG</p> <ul style="list-style-type: none"> • Die Seitenwände können heiß sein. Lassen Sie das Produkt abkühlen, bevor Sie es berühren. • Beachten Sie die Montageanweisungen, • Führen Sie keine Flüssigkeiten oder Fremdkörper in das Produkt ein. <p>Die Nichtbeachtung dieser Anweisung kann Körperverletzung oder Materialschäden zur Folge haben.</p>
<p>RIESGO DE DAÑOS MATERIALES Y DE SOBRECIENTAMIENTO DE LA UNIDAD</p> <ul style="list-style-type: none"> • Los paneles laterales del producto pueden estar calientes. Esperar que el producto se enfríe antes de tocarlo. • Respetar las instrucciones de montaje, y en particular los pares de apretado. • No dejar que penetren líquidos o cuerpos extraños en el producto. <p>Si no se respetan estas precauciones pueden producirse graves lesiones, daños materiales.</p>	<p>RISCHIO DI DANNI MATERIALI E D'INVOLUCRO CALDO</p> <ul style="list-style-type: none"> • I pannelli laterali dell'apparecchio possono scottare; lasciar quindi raffreddare il prodotto prima di toccarlo. • Seguire le istruzioni di montaggio corrette. • Non far entrare liquidi o oggetti estranei in questo apparecchio. <p>La mancata osservanza di questa precauzione può causare gravi rischi per l'incolumità personale o danni alle apparecchiature.</p>	<p>RISCO DE DANO MATERIAL E DE AQUECIMENTO</p> <ul style="list-style-type: none"> • Os painéis laterais do produto podem estar quentes; dê tempo ao produto para arrefecer antes de lhe tocar. • Siga devidamente as instruções de montagem. • Não permita a entrada de líquidos e de objectos estranhos no produto. <p>A não observância destas precauções pode provocar a morte, ferimentos graves ou danos materiais.</p>

