

Description

The BC107 and BC107B are silicon planar epitaxial NPN transistors in TO-18 metal case.

They are suitable for use in driver stages, low noise input stages and signal processing circuits of television receivers. The PNP complementary types are BC177 and BC177B respectively.

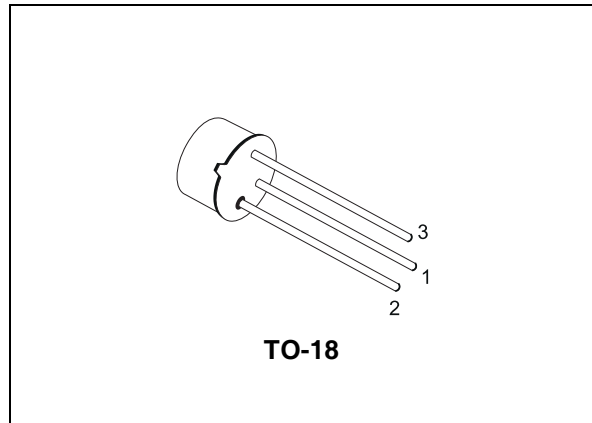

Internal schematic diagram

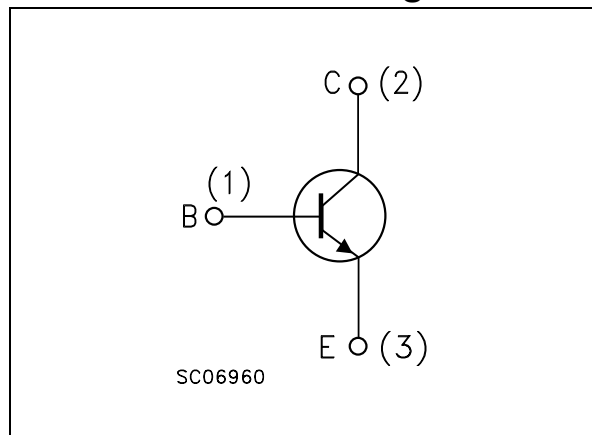

Order codes

Part Number	Marking	Package	Packing
BC107	BC107	TO-18	Bag
BC107A	BC107B	TO-18	Bag

1 Electrical ratings

Table 1. Absolute maximum rating

Symbol	Parameter	Value	Unit
V_{CBO}	Collector-emitter voltage ($I_E = 0$)	50	V
V_{CEO}	Collector-emitter voltage ($I_B = 0$)	45	V
V_{EBO}	Emitter-base voltage ($I_C = 0$)	6	V
I_C	Collector current	100	mA
P_{tot}	Total dissipation at $T_{amb} \leq 25^\circ\text{C}$	0.3	W
	at $T_{case} \leq 25^\circ\text{C}$	0.75	W
T_{stg}	Storage temperature	-55 to 175	$^\circ\text{C}$
T_J	Max. operating junction temperature	175	$^\circ\text{C}$

Table 2. Thermal data

Symbol	Parameter	Value	Unit
$R_{thj-case}$	Thermal resistance junction-case max	200	$^\circ\text{C}/\text{W}$
$R_{thj-amb}$	Thermal resistance junction-ambient max	500	$^\circ\text{C}/\text{W}$

2 Electrical characteristics

($T_{CASE} = 25^{\circ}C$; unless otherwise specified)

Table 3. Electrical characteristics

Symbol	Parameter	Test Conditions	Min.	Typ.	Max.	Unit
I_{CBO}	Collector cut-off current ($I_E = 0$)	$V_{CB} = 40V$			15	nA
		$V_{CB} = 40V$ $T_C = 150^{\circ}C$			15	μA
$V_{(BR)CBO}$	Collector-base breakdown voltage ($I_E = 0$)	$I_C = 10\mu A$	50			V
$V_{(BR)CEO}^{(1)}$	Collector-emitter breakdown voltage ($I_B = 0$)	$I_C = 10mA$	45			V
$V_{(BR)EBO}$	Emitter-base breakdown voltage ($I_C = 0$)	$I_E = 10\mu A$	6			V
$V_{CE(sat)}^{(1)}$	Collector-emitter saturation voltage	$I_C = 10mA$ $I_B = 0.5mA$		70	250	mV
		$I_C = 100mA$ $I_B = 5mA$		200	600	mV
$V_{BE(sat)}^{(1)}$	Base-emitter saturation voltage	$I_C = 10mA$ $I_B = 0.5mA$		750		mV
		$I_C = 100mA$ $I_B = 5mA$		950		mV
$V_{BE(on)}^{(1)}$	Base-emitter on voltage	$I_C = 2mA$ $V_{CE} = 5V$	550	650	700	mV
		$I_C = 10mA$ $V_{CE} = 5V$		700	770	mV
h_{FE}	DC current gain	$I_C = 2mA$ $V_{CE} = 5V$	110		450	
		for BC107	200		450	
		$I_C = 10\mu A$ $V_{CE} = 5V$		120		
		for BC107	40	150		
h_{fe}	Small signal current gain	$I_C = 2mA$ $V_{CE} = 5V$		250		
		$f = 1kHz$		300		
		for BC107		2		
		$I_C = 10mA$ $V_{CE} = 5V$				
		$f = 100MHz$				
C_{CBO}	Collector-base capacitance	$I_E = 0$ $V_{CB} = 10V$ $f = 1MHz$		4	6	pF
C_{EBO}	Emitter-base capacitance	$I_C = 0$ $V_{EB} = 0.5V$ $f = 1MHz$		12		pF
NF	Noise figure	$I_C = 0.2mA$ $V_{CE} = 5V$ $f = 1kHz$ $R_G = 2k\Omega$ $B = 200Hz$		2	10	dB
h_{ie}	Input impedance	$I_C = 2mA$ $V_{CE} = 5V$		4		k Ω
		$f = 1kHz$		4.8		k Ω
		for BC107				
		for BC107B				

Symbol	Parameter	Test Conditions	Min.	Typ.	Max.	Unit
h_{re}	Reverse voltage ratio	$I_C = 2\text{mA}$ $V_{CE} = 5\text{V}$ $f = 1\text{kHz}$ for BC107 for BC107B		2.2 2.7		10^{-4} 10^{-4}
h_{oe}	Output admittance	$I_C = 2\text{mA}$ $V_{CE} = 5\text{V}$ $f = 1\text{kHz}$ for BC107 for BC107B		30 26		μS μS

(1) Pulsed: Pulse duration = 300 μs , duty cycle $\leq 1\%$

2.1 Electrical characteristics (curves)

Figure 1. DC normalized current gain

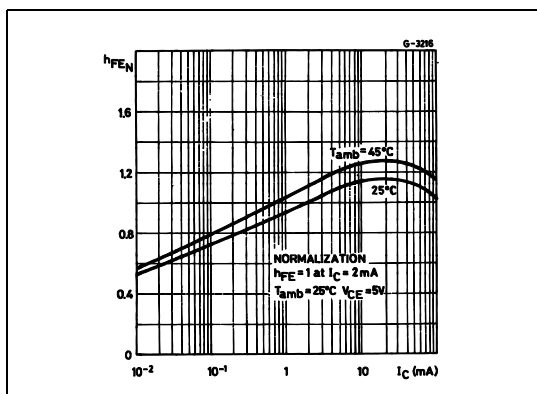

Figure 2. Collector-emitter saturation voltage

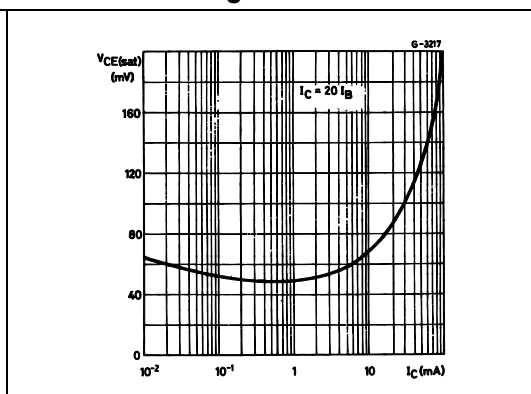

Figure 3. Collector-base capacitance

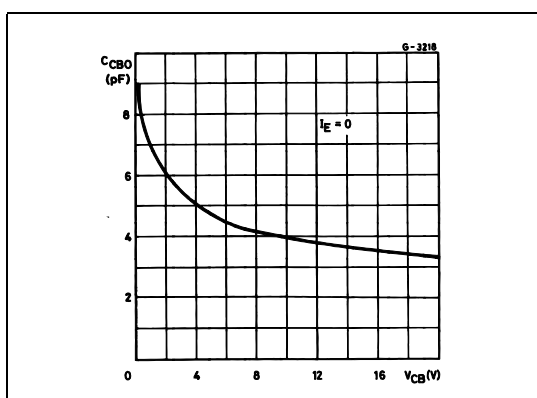

Figure 4. Transition frequency

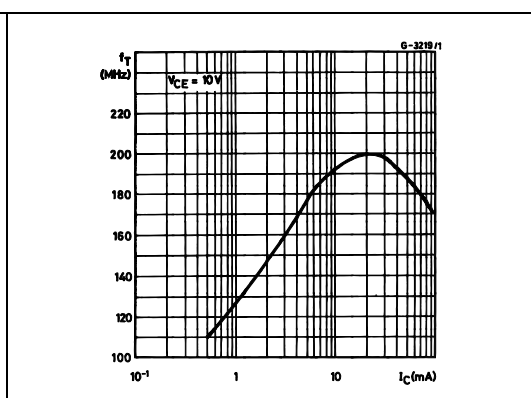
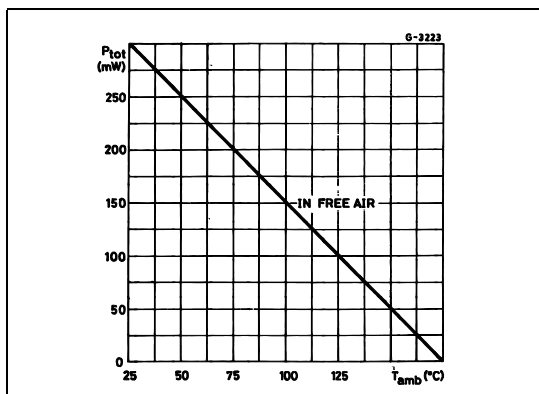

Figure 5. Power rating chart



3 Package mechanical data

In order to meet environmental requirements, ST offers these devices in ECOPACK® packages. These packages have a Lead-free second level interconnect . The category of second level interconnect is marked on the package and on the inner box label, in compliance with JEDEC Standard JESD97. The maximum ratings related to soldering conditions are also marked on the inner box label. ECOPACK is an ST trademark. ECOPACK specifications are available at: www.st.com

TO-18 MECHANICAL DATA

DIM.	mm			inch		
	MIN.	TYP.	MAX.	MIN.	TYP.	MAX.
A		12.7			0.500	
B			0.49			0.019
D			5.3			0.208
E			4.9			0.193
F			5.8			0.228
G	2.54			0.100		
H			1.2			0.047
I			1.16			0.045
L	45°			45°		

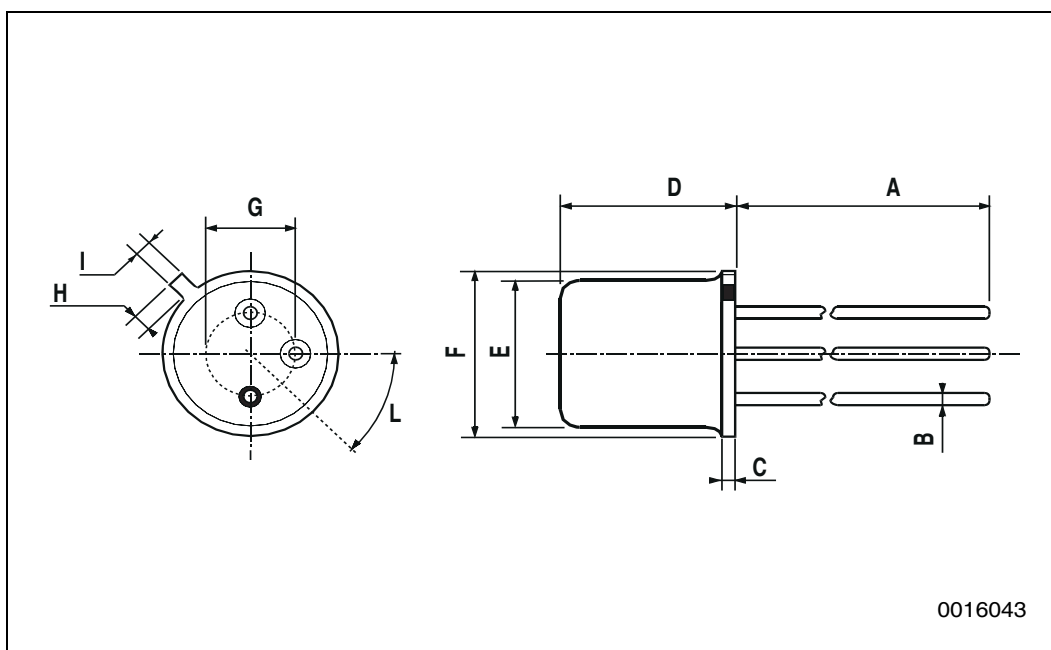

4 Revision history

Table 4. Revision history

Date	Revision	Changes
01-Dec-2002	1	First release
06-Nov-2006	2	The document has been reformatted

Please Read Carefully:

Information in this document is provided solely in connection with ST products. STMicroelectronics NV and its subsidiaries ("ST") reserve the right to make changes, corrections, modifications or improvements, to this document, and the products and services described herein at any time, without notice.

All ST products are sold pursuant to ST's terms and conditions of sale.

Purchasers are solely responsible for the choice, selection and use of the ST products and services described herein, and ST assumes no liability whatsoever relating to the choice, selection or use of the ST products and services described herein.

No license, express or implied, by estoppel or otherwise, to any intellectual property rights is granted under this document. If any part of this document refers to any third party products or services it shall not be deemed a license grant by ST for the use of such third party products or services, or any intellectual property contained therein or considered as a warranty covering the use in any manner whatsoever of such third party products or services or any intellectual property contained therein.

UNLESS OTHERWISE SET FORTH IN ST'S TERMS AND CONDITIONS OF SALE ST DISCLAIMS ANY EXPRESS OR IMPLIED WARRANTY WITH RESPECT TO THE USE AND/OR SALE OF ST PRODUCTS INCLUDING WITHOUT LIMITATION IMPLIED WARRANTIES OF MERCHANTABILITY, FITNESS FOR A PARTICULAR PURPOSE (AND THEIR EQUIVALENTS UNDER THE LAWS OF ANY JURISDICTION), OR INFRINGEMENT OF ANY PATENT, COPYRIGHT OR OTHER INTELLECTUAL PROPERTY RIGHT.

UNLESS EXPRESSLY APPROVED IN WRITING BY AN AUTHORIZED REPRESENTATIVE OF ST, ST PRODUCTS ARE NOT RECOMMENDED, AUTHORIZED OR WARRANTED FOR USE IN MILITARY, AIR CRAFT, SPACE, LIFE SAVING, OR LIFE SUSTAINING APPLICATIONS, NOR IN PRODUCTS OR SYSTEMS, WHERE FAILURE OR MALFUNCTION MAY RESULT IN PERSONAL INJURY, DEATH, OR SEVERE PROPERTY OR ENVIRONMENTAL DAMAGE. ST PRODUCTS WHICH ARE NOT SPECIFIED AS "AUTOMOTIVE GRADE" MAY ONLY BE USED IN AUTOMOTIVE APPLICATIONS AT USER'S OWN RISK.

Resale of ST products with provisions different from the statements and/or technical features set forth in this document shall immediately void any warranty granted by ST for the ST product or service described herein and shall not create or extend in any manner whatsoever, any liability of ST.

ST and the ST logo are trademarks or registered trademarks of ST in various countries.

Information in this document supersedes and replaces all information previously supplied.

The ST logo is a registered trademark of STMicroelectronics. All other names are the property of their respective owners.

© 2006 STMicroelectronics - All rights reserved

STMicroelectronics group of companies

Australia - Belgium - Brazil - Canada - China - Czech Republic - Finland - France - Germany - Hong Kong - India - Israel - Italy - Japan - Malaysia - Malta - Morocco - Singapore - Spain - Sweden - Switzerland - United Kingdom - United States of America

www.st.com

