



BU931 BU931P, BU931T

High voltage ignition coil driver
NPN power Darlington transistors

Features

- Very rugged Bipolar technology
- High operating junction temperature
- Wide range of packages

Applications

- High ruggedness electronic ignitions

Description

The devices are bipolar Darlington transistors manufactured using Multi-Epitaxial Planar technology. They have been properly designed to be used in automotive environment as electronic ignition power actuators.

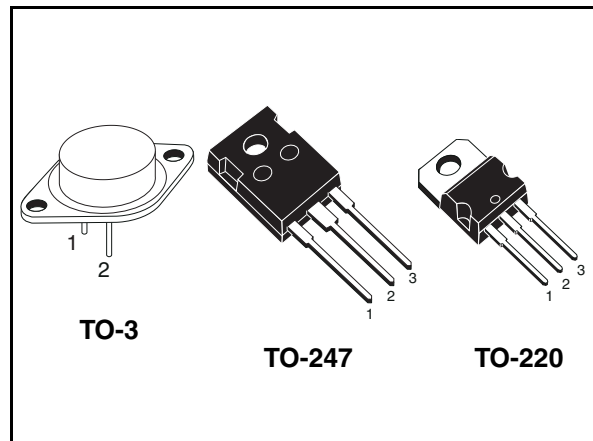

Figure 1. Internal schematic diagrams

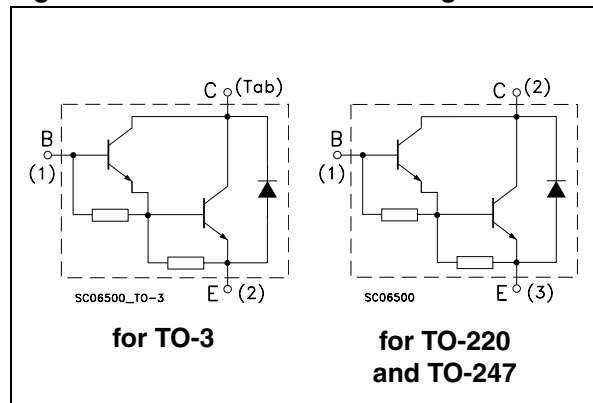

Table 1. Device summary

Order codes	Marking	Package	Packaging
BU931	BU931	TO-3	Tray
BU931P	BU931P	TO-247	Tube
BU931T	BU931T	TO-220	Tube

Content

1	Electrical ratings	3
2	Electrical characteristics	4
	2.1 Electrical characteristics (curves)	5
3	Test circuits	7
4	Package mechanical data	8
5	Revision history	12

1 Electrical ratings

Table 2. Absolute maximum ratings

Symbol	Parameter	Value			Unit
		BU931	BU931P	BU931T	
V_{CES}	Collector-emitter voltage ($V_{BE} = 0$)	500			V
V_{CEO}	Collector-emitter voltage ($I_B = 0$)	400			V
V_{EBO}	Emitter-base voltage ($I_C = 0$)	5			V
I_C	Collector current	15		10	A
I_{CM}	Collector peak current	30		20	A
I_B	Base current	1			A
I_{BM}	Base peak current	5			A
P_{TOT}	Total dissipation at $T_c = 25\text{ °C}$	175	135	125	W
T_{stg}	Storage temperature	-65 to 200	-65 to 175		°C
T_J	Max. operating junction temperature	200	175		

Table 3. Thermal data

Symbol	Parameter	Value			Unit
		BU931	BU931P	BU931T	
$R_{thj-case}$	Thermal resistance junction-case max.	1	1.1	1.2	°C/W

2 Electrical characteristics

($T_{\text{case}} = 25\text{ °C}$; unless otherwise specified)

Table 4. Electrical characteristics

Symbol	Parameter	Test conditions	Min.	Typ.	Max.	Unit
I_{CES}	Collector cut-off current ($V_{\text{BE}} = 0$)	$V_{\text{CE}} = 500\text{ V}$ $V_{\text{CE}} = 500\text{ V}$ $T_{\text{C}} = 125\text{ °C}$			100 0.5	μA mA
I_{CEO}	Collector cut-off current ($I_{\text{B}} = 0$)	$V_{\text{CE}} = 450\text{ V}$ $V_{\text{CE}} = 450\text{ V}$ $T_{\text{C}} = 125\text{ °C}$			100 0.5	μA mA
I_{EBO}	Emitter cut-off current ($I_{\text{C}} = 0$)	$V_{\text{EB}} = 5\text{ V}$			20	mA
$V_{\text{CEO(sus)}}^{(1)}$	Collector-emitter sustaining voltage ($I_{\text{B}} = 0$)	$I_{\text{C}} = 10\text{ mA}$ $L = 10\text{ mH}$ $V_{\text{clamp}} = 400\text{ V}$ see Figure 14	400			V
$V_{\text{CE(sat)}}^{(1)}$	Collector-emitter saturation voltage	$I_{\text{C}} = 7\text{ A}$ $I_{\text{B}} = 70\text{ mA}$ $I_{\text{C}} = 8\text{ A}$ $I_{\text{B}} = 100\text{ mA}$ $I_{\text{C}} = 10\text{ A}$ $I_{\text{B}} = 250\text{ mA}$			1.6 1.8 1.8	V V V
$V_{\text{BE(sat)}}^{(1)}$	Base-emitter saturation voltage	$I_{\text{C}} = 7\text{ A}$ $I_{\text{B}} = 70\text{ mA}$ $I_{\text{C}} = 8\text{ A}$ $I_{\text{B}} = 100\text{ mA}$ $I_{\text{C}} = 10\text{ A}$ $I_{\text{B}} = 250\text{ mA}$			2.2 2.4 2.5	V V V
$h_{\text{FE}}^{(1)}$	DC current gain	$I_{\text{C}} = 5\text{ A}$ $V_{\text{CE}} = 10\text{ V}$	300			
V_{F}	Diode forward voltage	$I_{\text{F}} = 10\text{ A}$			2.5	V
	Functional test	$V_{\text{CC}} = 24\text{ V}$ $L = 7\text{ mH}$ $V_{\text{clamp}} = 400\text{ V}$ see Figure 11	8			A
t_{s} t_{f}	Inductive Load Storage time Fall time	$I_{\text{C}} = 7\text{ A}$ $V_{\text{clamp}} = 300\text{ V}$ $I_{\text{B}} = 70\text{ mA}$ $L = 7\text{ mH}$ $V_{\text{BE}} = 0$ $R_{\text{BE}} = 47\text{ }\Omega$ $V_{\text{CC}} = 12\text{ V}$ see Figure 13		15 0.5		μs μs

1. Pulsed duration = 300 μs , duty cycle $\leq 1.5\%$

2.1 Electrical characteristics (curves)

Figure 2. Safe operating area for BU931 and BU931P Figure 3. Safe operating area for BU931T and BU931P

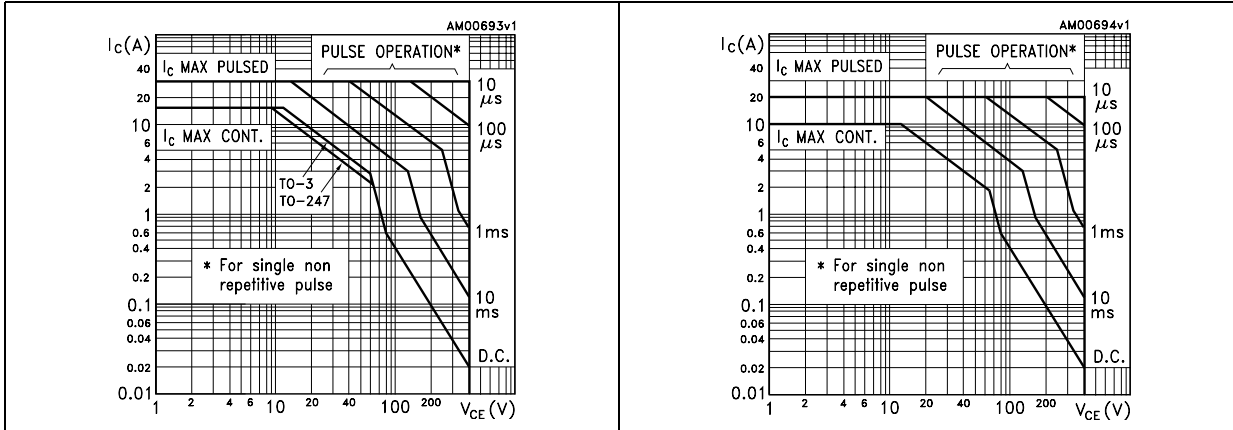

Figure 4. DC current gain

Figure 5. Switching time inductive load

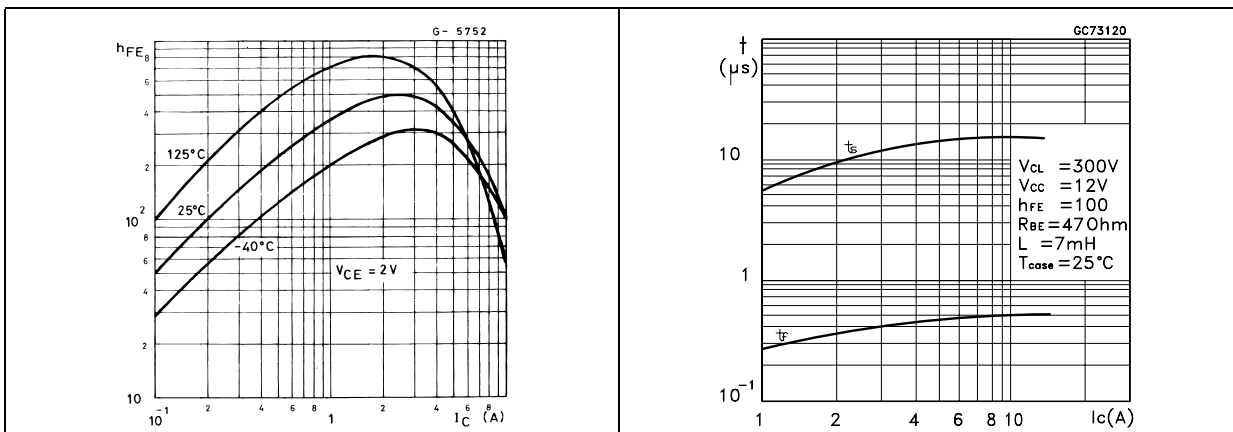

Figure 6. Collector-emitter saturation voltage @ $h_{FE} = 50$

Figure 7. Collector-emitter saturation voltage @ $h_{FE} = 100$

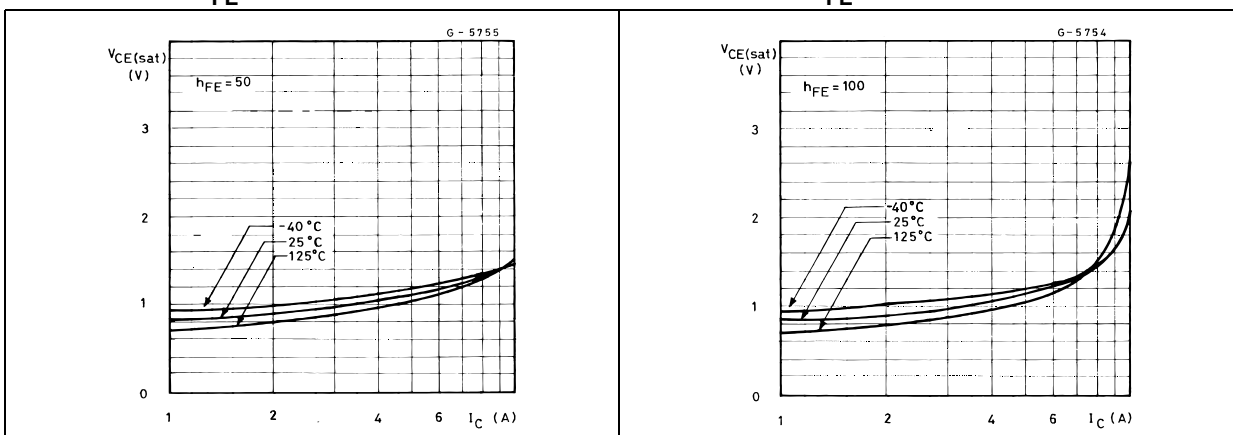

Figure 8. Collector-emitter saturation voltage Figure 9. Base-emitter saturation voltage @ $h_{FE} = 50$

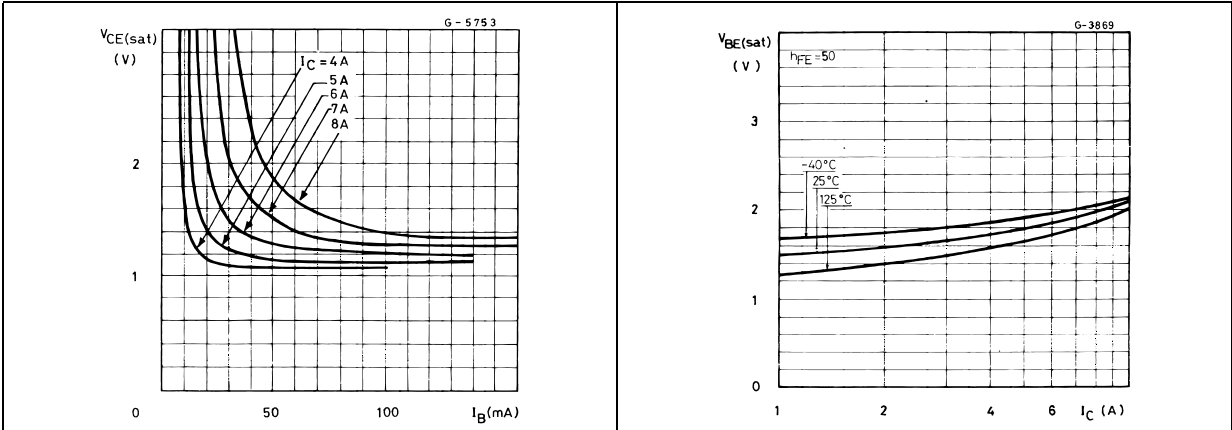
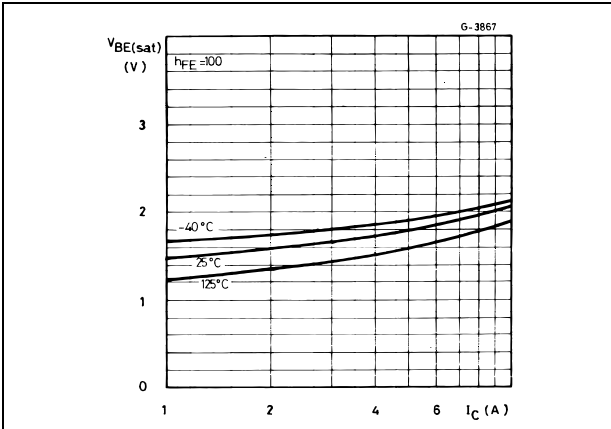

Figure 10. Base-emitter saturation voltage @ $h_{FE} = 100$



3 Test circuits

Figure 11. Functional test circuit

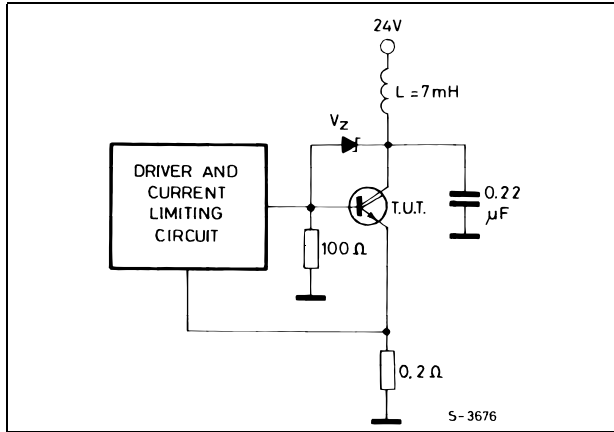

Figure 12. Functional test waveforms

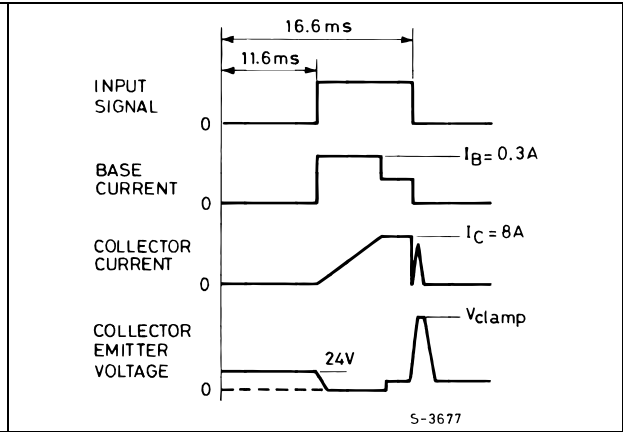

Figure 13. Switching time test circuit

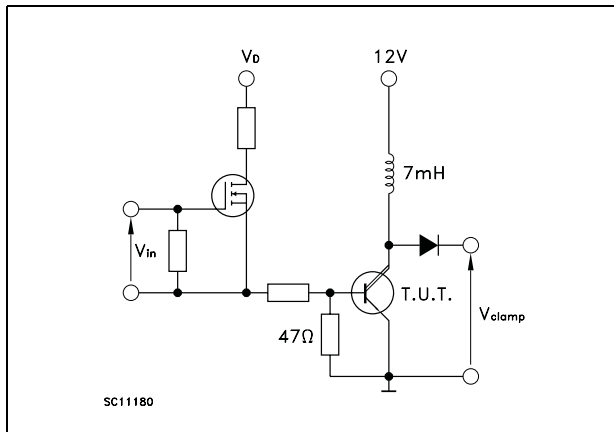
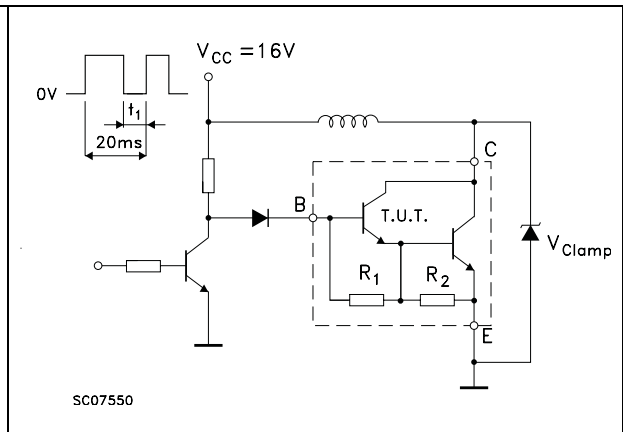

Figure 14. Sustaining voltage test circuit



4 Package mechanical data

In order to meet environmental requirements, ST offers these devices in ECOPACK® packages. These packages have a lead-free second level interconnect . The category of second level interconnect is marked on the package and on the inner box label, in compliance with JEDEC Standard JESD97. The maximum ratings related to soldering conditions are also marked on the inner box label. ECOPACK is an ST trademark. ECOPACK specifications are available at: www.st.com

TO-3 mechanical data

DIM.	mm.		
	min.	typ	max.
A	11.00		13.10
B	0.97		1.15
C	1.50		1.65
D	8.32		8.92
E	19.00		20.00
G	10.70		11.10
N	16.50		17.20
P	25.00		26.00
R	4.00		4.09
U	38.50		39.30
V	30.00		30.30

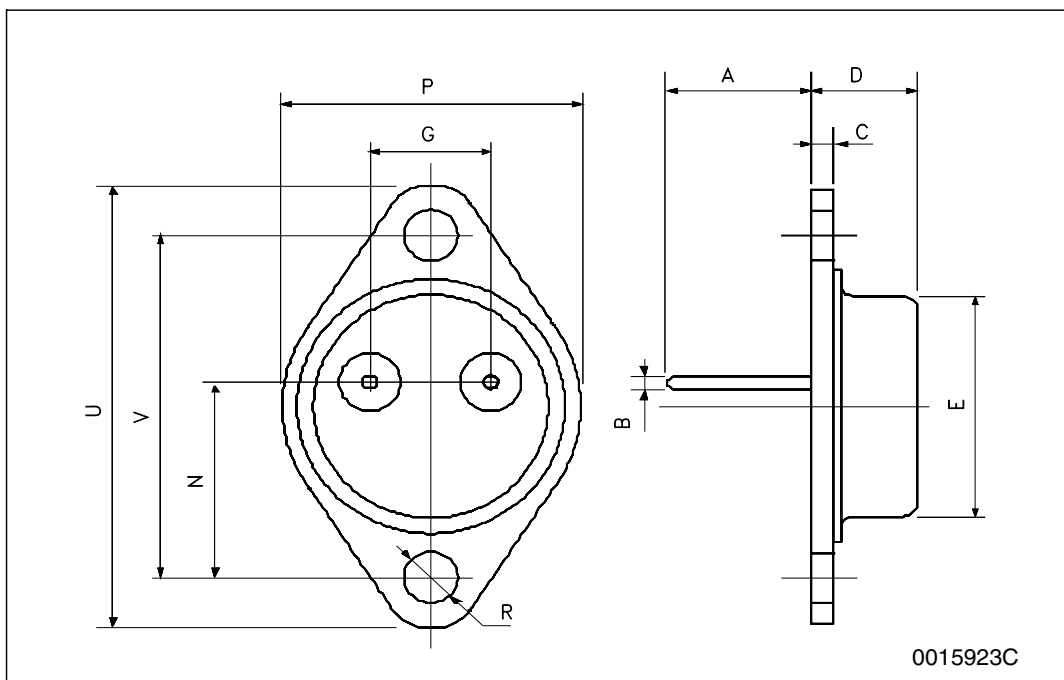

TO-247 Mechanical data

Dim.	mm.		
	Min.	Typ	Max.
A	4.85		5.15
A1	2.20		2.60
b	1.0		1.40
b1	2.0		2.40
b2	3.0		3.40
c	0.40		0.80
D	19.85		20.15
E	15.45		15.75
e		5.45	
L	14.20		14.80
L1	3.70		4.30
L2		18.50	
øP	3.55		3.65
øR	4.50		5.50
S		5.50	

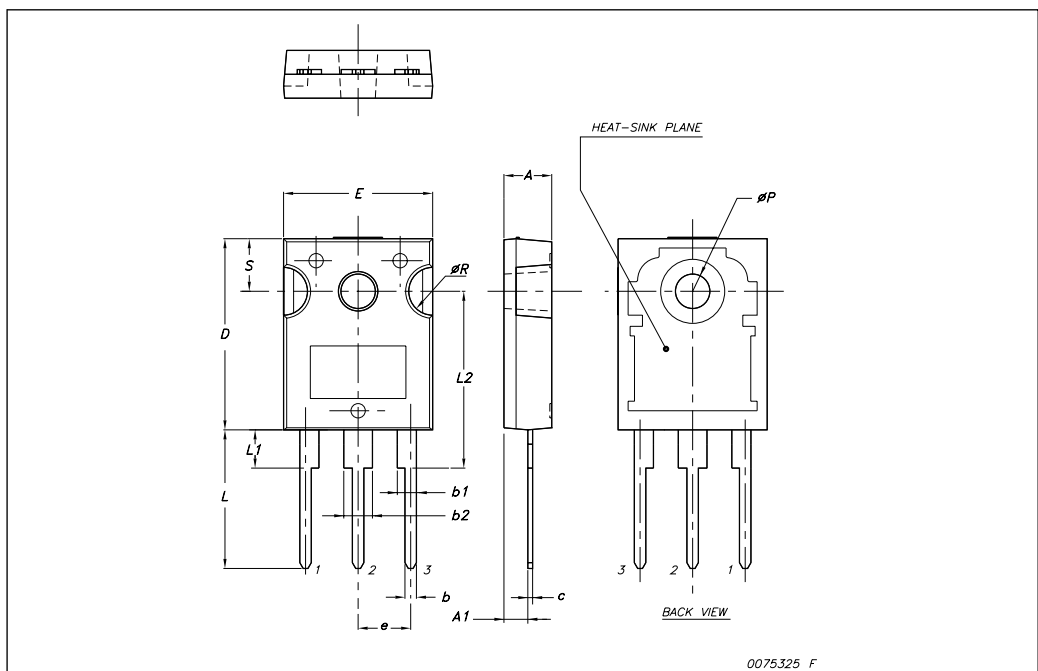

TO-220 mechanical data

Dim	mm			inch		
	Min	Typ	Max	Min	Typ	Max
A	4.40		4.60	0.173		0.181
b	0.61		0.88	0.024		0.034
b1	1.14		1.70	0.044		0.066
c	0.48		0.70	0.019		0.027
D	15.25		15.75	0.6		0.62
D1		1.27			0.050	
E	10		10.40	0.393		0.409
e	2.40		2.70	0.094		0.106
e1	4.95		5.15	0.194		0.202
F	1.23		1.32	0.048		0.051
H1	6.20		6.60	0.244		0.256
J1	2.40		2.72	0.094		0.107
L	13		14	0.511		0.551
L1	3.50		3.93	0.137		0.154
L20		16.40			0.645	
L30		28.90			1.137	
ØP	3.75		3.85	0.147		0.151
Q	2.65		2.95	0.104		0.116

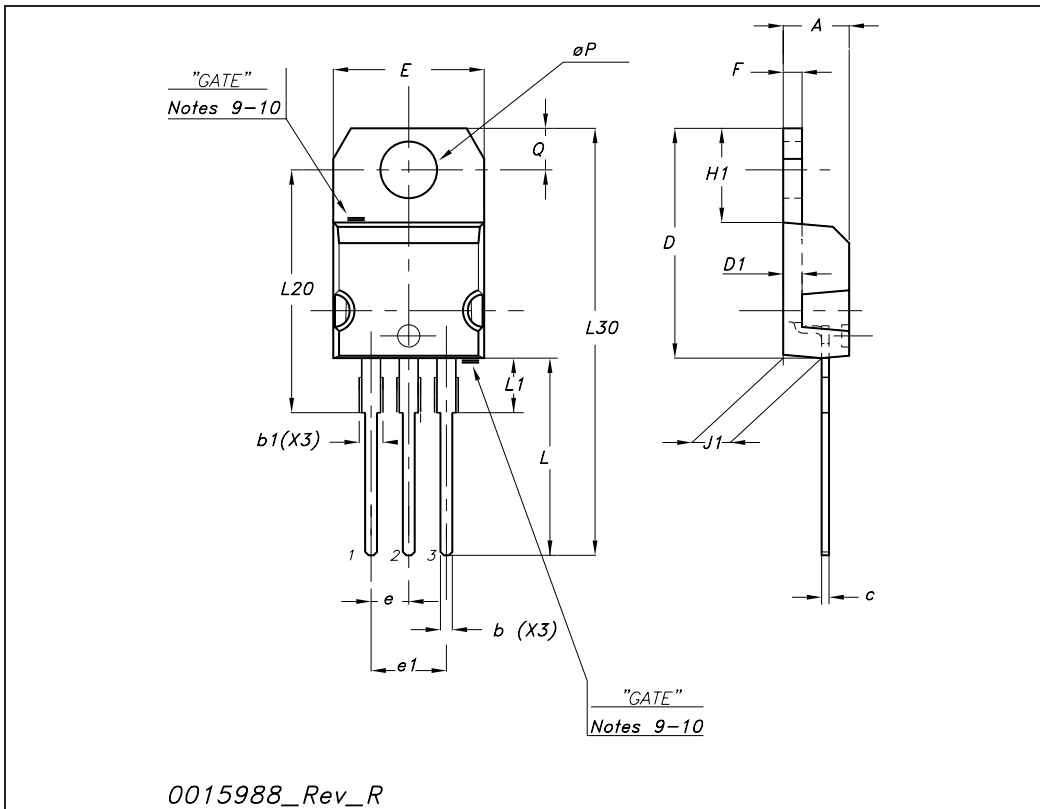

5 Revision history

Table 5. Document revision history

Date	Revision	Changes
21-Jun-2004	2	
18-Nov-2008	3	Package changed from TO-218 to TO-247 for BU931P. Inserted type in TO-220 (BU931T).

Please Read Carefully:

Information in this document is provided solely in connection with ST products. STMicroelectronics NV and its subsidiaries ("ST") reserve the right to make changes, corrections, modifications or improvements, to this document, and the products and services described herein at any time, without notice.

All ST products are sold pursuant to ST's terms and conditions of sale.

Purchasers are solely responsible for the choice, selection and use of the ST products and services described herein, and ST assumes no liability whatsoever relating to the choice, selection or use of the ST products and services described herein.

No license, express or implied, by estoppel or otherwise, to any intellectual property rights is granted under this document. If any part of this document refers to any third party products or services it shall not be deemed a license grant by ST for the use of such third party products or services, or any intellectual property contained therein or considered as a warranty covering the use in any manner whatsoever of such third party products or services or any intellectual property contained therein.

UNLESS OTHERWISE SET FORTH IN ST'S TERMS AND CONDITIONS OF SALE ST DISCLAIMS ANY EXPRESS OR IMPLIED WARRANTY WITH RESPECT TO THE USE AND/OR SALE OF ST PRODUCTS INCLUDING WITHOUT LIMITATION IMPLIED WARRANTIES OF MERCHANTABILITY, FITNESS FOR A PARTICULAR PURPOSE (AND THEIR EQUIVALENTS UNDER THE LAWS OF ANY JURISDICTION), OR INFRINGEMENT OF ANY PATENT, COPYRIGHT OR OTHER INTELLECTUAL PROPERTY RIGHT.

UNLESS EXPRESSLY APPROVED IN WRITING BY AN AUTHORIZED ST REPRESENTATIVE, ST PRODUCTS ARE NOT RECOMMENDED, AUTHORIZED OR WARRANTED FOR USE IN MILITARY, AIR CRAFT, SPACE, LIFE SAVING, OR LIFE SUSTAINING APPLICATIONS, NOR IN PRODUCTS OR SYSTEMS WHERE FAILURE OR MALFUNCTION MAY RESULT IN PERSONAL INJURY, DEATH, OR SEVERE PROPERTY OR ENVIRONMENTAL DAMAGE. ST PRODUCTS WHICH ARE NOT SPECIFIED AS "AUTOMOTIVE GRADE" MAY ONLY BE USED IN AUTOMOTIVE APPLICATIONS AT USER'S OWN RISK.

Resale of ST products with provisions different from the statements and/or technical features set forth in this document shall immediately void any warranty granted by ST for the ST product or service described herein and shall not create or extend in any manner whatsoever, any liability of ST.

ST and the ST logo are trademarks or registered trademarks of ST in various countries.

Information in this document supersedes and replaces all information previously supplied.

The ST logo is a registered trademark of STMicroelectronics. All other names are the property of their respective owners.

© 2008 STMicroelectronics - All rights reserved

STMicroelectronics group of companies

Australia - Belgium - Brazil - Canada - China - Czech Republic - Finland - France - Germany - Hong Kong - India - Israel - Italy - Japan - Malaysia - Malta - Morocco - Singapore - Spain - Sweden - Switzerland - United Kingdom - United States of America

www.st.com