

Distributed by:

JAMECO[®]
ELECTRONICS

www.Jameco.com ♦ 1-800-831-4242

The content and copyrights of the attached
material are the property of its owner.

Jameco Part Number 1979530



BU931 BU931P

HIGH VOLTAGE IGNITION COIL DRIVER NPN POWER DARLINGTON

- VERY RUGGED BIPOLAR TECHNOLOGY
- HIGH OPERATING JUNCTION TEMPERATURE
- WIDE RANGE OF PACKAGES

APPLICATIONS

- HIGH RUGGEDNESS ELECTRONIC IGNITIONS

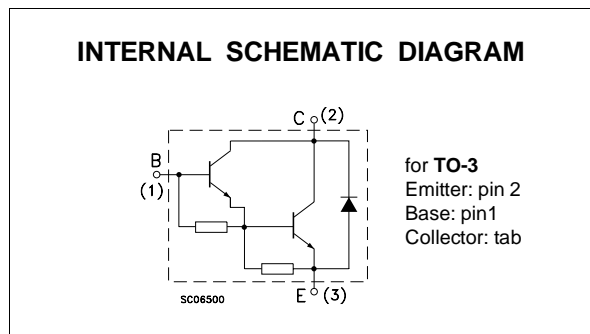
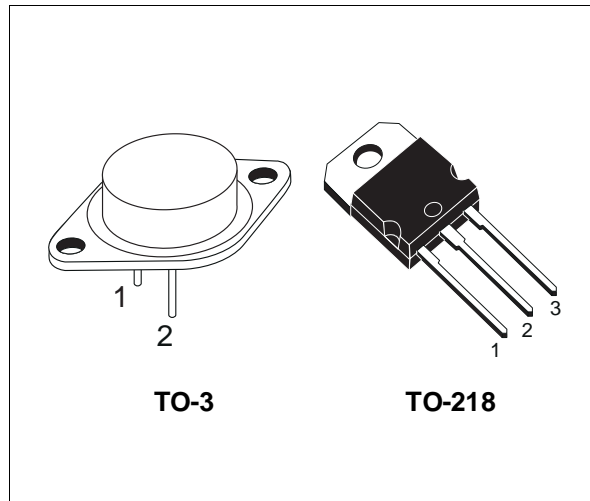

ABSOLUTE MAXIMUM RATINGS

Symbol	Parameter	Value		Unit
		BU931	BU931P	
V_{CES}	Collector-Emitter Voltage ($V_{BE} = 0$)	500		V
V_{CEO}	Collector-Emitter Voltage ($I_B = 0$)	400		V
V_{EBO}	Emitter-Base Voltage ($I_C = 0$)	5		V
I_C	Collector Current	15		A
I_{CM}	Collector Peak Current	30		A
I_B	Base Current	1		A
I_{BM}	Base Peak Current	5		A
P_{tot}	Total Dissipation at $T_c = 25^\circ\text{C}$	175	135	W
T_{stg}	Storage Temperature	-65 to 200	-65 to 175	$^\circ\text{C}$
T_j	Max. Operating Junction Temperature	200	175	$^\circ\text{C}$

BU931 / BU931P

THERMAL DATA

		TO-3	TO-218	
$R_{thj-case}$	Thermal Resistance Junction-case Max	1	1.1	°C/W

ELECTRICAL CHARACTERISTICS ($T_{case} = 25\text{ }^{\circ}\text{C}$ unless otherwise specified)

Symbol	Parameter	Test Conditions	Min.	Typ.	Max.	Unit
I_{CES}	Collector Cut-off Current ($V_{BE} = 0$)	$V_{CE} = 500\text{ V}$ $V_{CE} = 500\text{ V}$ $T_j = 125\text{ }^{\circ}\text{C}$			100 0.5	μA mA
I_{CEO}	Collector Cut-off Current ($I_B = 0$)	$V_{CE} = 450\text{ V}$ $V_{CE} = 450\text{ V}$ $T_j = 125\text{ }^{\circ}\text{C}$			100 0.5	μA mA
I_{EBO}	Emitter Cut-off Current ($I_C = 0$)	$V_{EB} = 5\text{ V}$			20	mA
$V_{CEO(sus)}^*$	Collector-Emitter Sustaining Voltage ($I_B = 0$)	$I_C = 100\text{ mA}$ $L = 10\text{ mH}$ $V_{Clamp} = 400\text{ V}$ (See Fig.4)	400			V
$V_{CE(sat)}^*$	Collector-Emitter Saturation Voltage	$I_C = 7\text{ A}$ $I_B = 70\text{ mA}$ $I_C = 8\text{ A}$ $I_B = 100\text{ mA}$ $I_C = 10\text{ A}$ $I_B = 250\text{ mA}$			1.6 1.8 1.8	V V V
$V_{BE(sat)}^*$	Base-Emitter Saturation Voltage	$I_C = 7\text{ A}$ $I_B = 70\text{ mA}$ $I_C = 8\text{ A}$ $I_B = 100\text{ mA}$ $I_C = 10\text{ A}$ $I_B = 250\text{ mA}$			2.2 2.4 2.5	V V V
h_{FE}^*	DC Current Gain	$I_C = 5\text{ A}$ $V_{CE} = 10\text{ V}$	300			
V_F	Diode Forward Voltage	$I_F = 10\text{ A}$			2.5	V
	Functional Test (see fig. 1)	$V_{CC} = 24\text{ V}$ $V_{clamp} = 400\text{ V}$ $L = 7\text{ mH}$	8			A
t_s	INDUCTIVE LOAD Storage Time	$V_{CC} = 12\text{ V}$ $V_{clamp} = 300\text{ V}$ $L = 7\text{ mH}$		15		μs
t_r	Fall Time (see fig. 3)	$I_C = 7\text{ A}$ $I_B = 70\text{ mA}$ $V_{BE} = 0$ $R_{BE} = 47\text{ }\Omega$		0.5		μs

* Pulsed: Pulse duration = 300 μs , duty cycle 1.5 %

Safe Operating Area

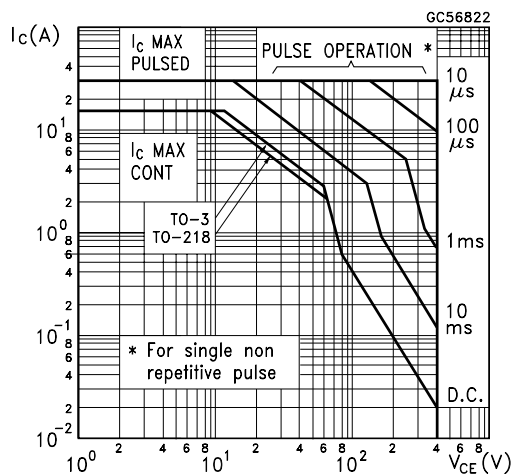

DC Current Gain

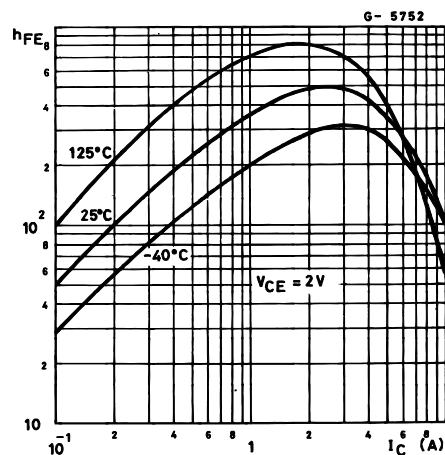

Collector Emitter Saturation Voltage

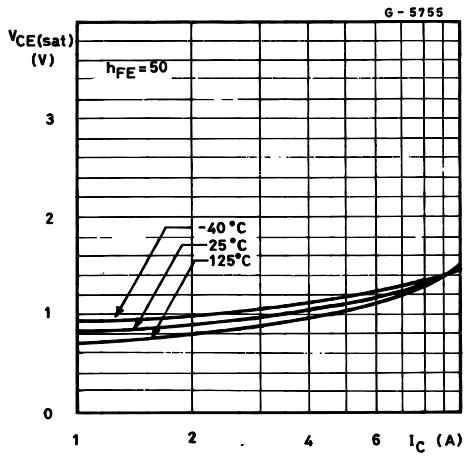

Collector Emitter Saturation Voltage

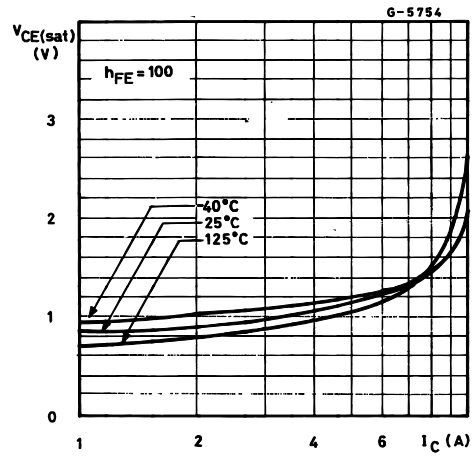

Collector Emitter Saturation Voltage

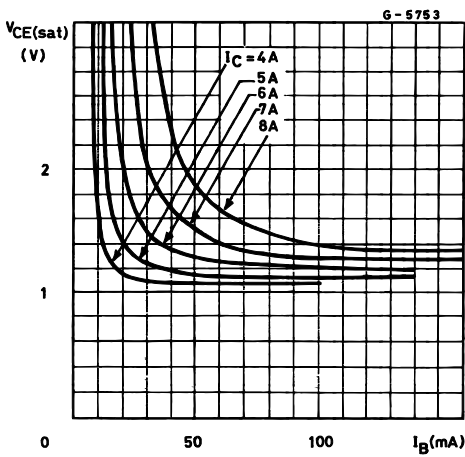

Base Emitter Saturation Voltage

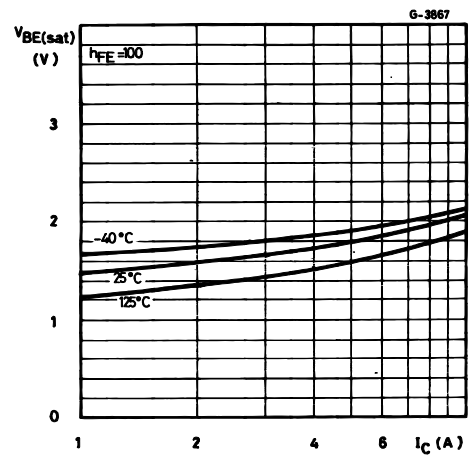

Base Emitter Saturation Voltage

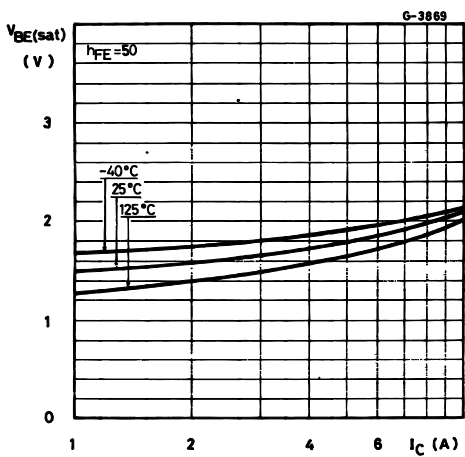

Switching Time Inductive Load

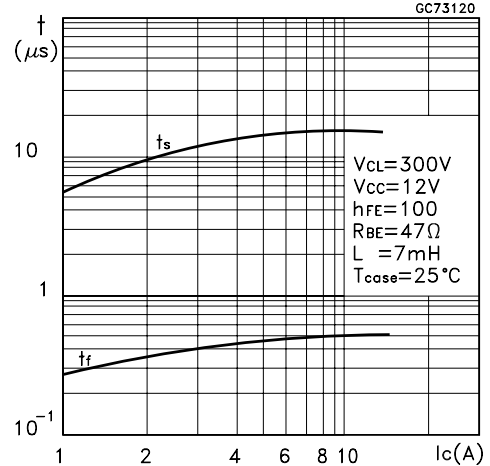

FIGURE 1: Functional Test Circuit

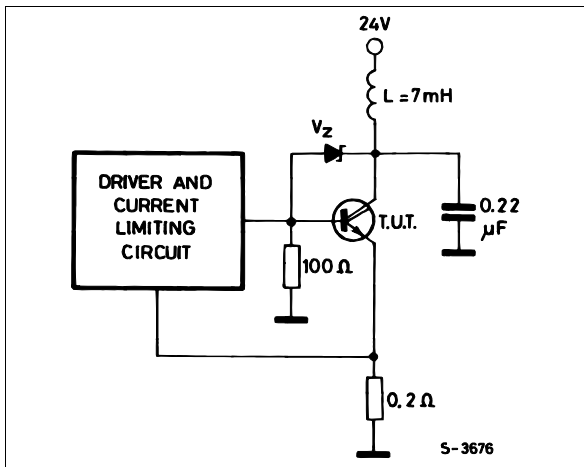

FIGURE 2: Functional Test Waveforms

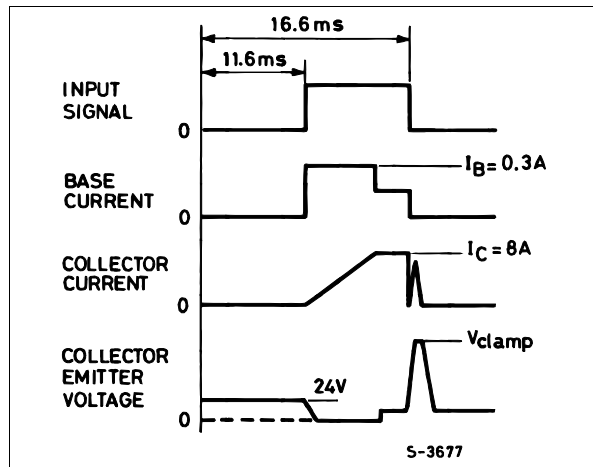

FIGURE 3: Switching Time Test Circuit

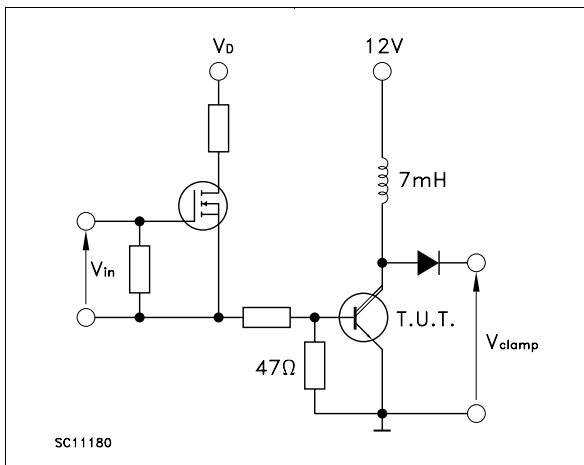
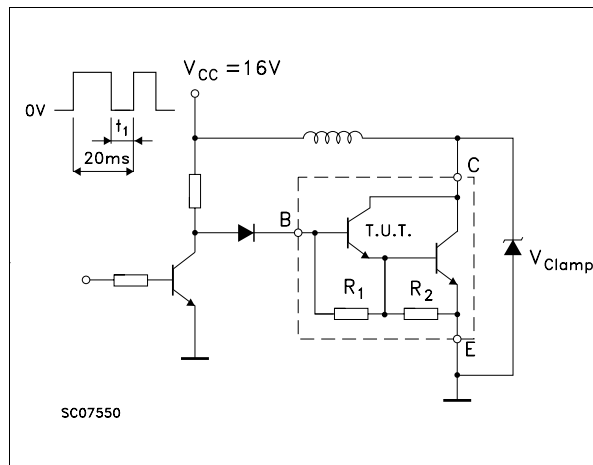
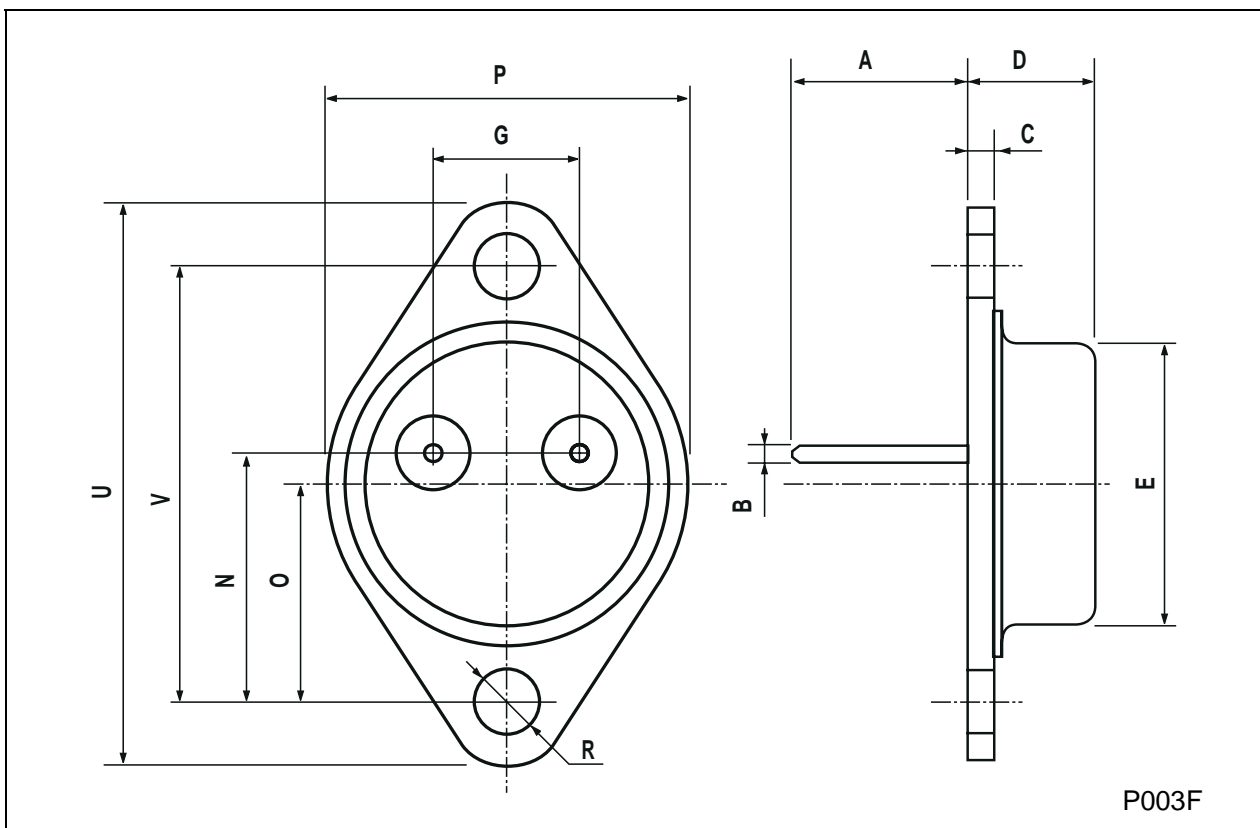

FIGURE 4: Sustaining Voltage Test Circuit



TO-3 MECHANICAL DATA

DIM.	mm			inch		
	MIN.	TYP.	MAX.	MIN.	TYP.	MAX.
A	11.00		13.10	0.433		0.516
B	0.97		1.15	0.038		0.045
C	1.50		1.65	0.059		0.065
D	8.32		8.92	0.327		0.351
E	19.00		20.00	0.748		0.787
G	10.70		11.10	0.421		0.437
N	16.50		17.20	0.649		0.677
P	25.00		26.00	0.984		1.023
R	4.00		4.09	0.157		0.161
U	38.50		39.30	1.515		1.547
V	30.00		30.30	1.187		1.193



P003F

TO-218 (SOT-93) MECHANICAL DATA

DIM.	mm			inch		
	MIN.	TYP.	MAX.	MIN.	TYP.	MAX.
A	4.7		4.9	0.185		0.193
C	1.17		1.37	0.046		0.054
D		2.5			0.098	
E	0.5		0.78	0.019		0.030
F	1.1		1.3	0.043		0.051
G	10.8		11.1	0.425		0.437
H	14.7		15.2	0.578		0.598
L2	-		16.2	-		0.637
L3		18			0.708	
L5	3.95		4.15	0.155		0.163
L6		31			1.220	
R	-		12.2	-		0.480
Ø	4		4.1	0.157		0.161

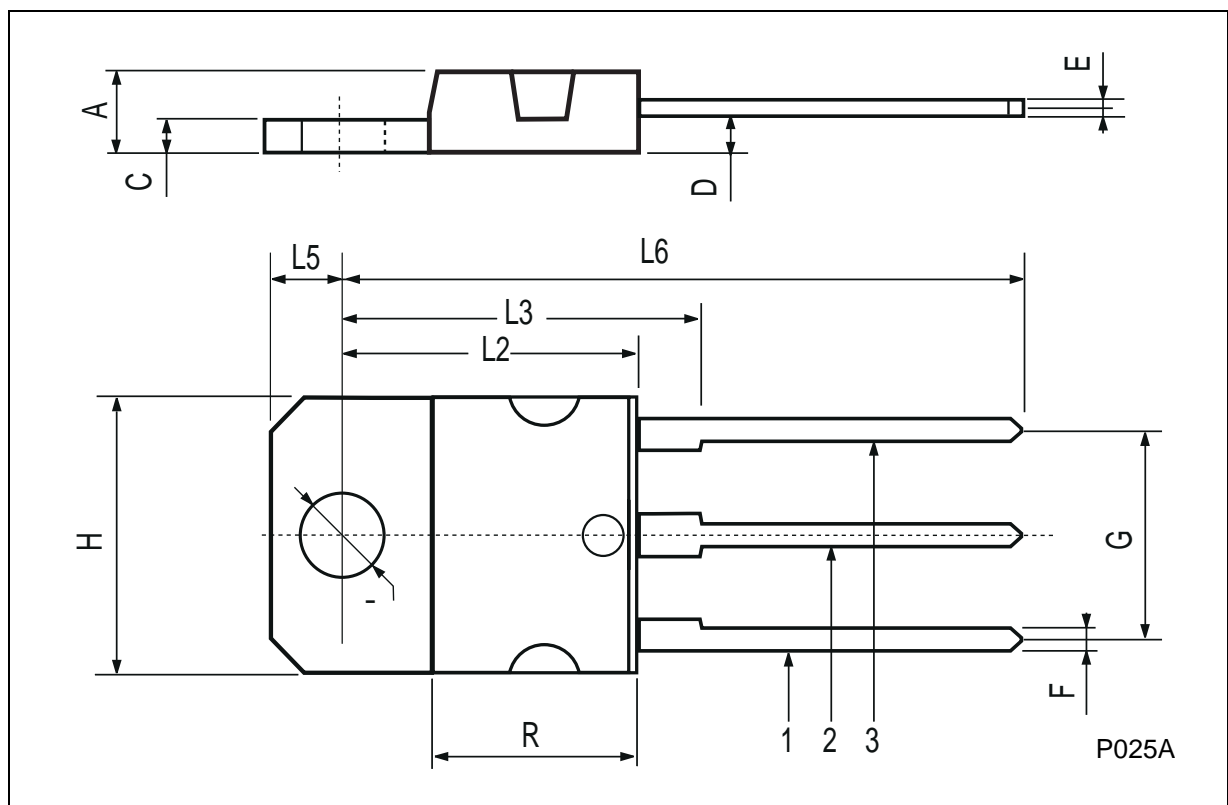

Information furnished is believed to be accurate and reliable. However, STMicroelectronics assumes no responsibility for the consequences of use of such information nor for any infringement of patents or other rights of third parties which may result from its use. No license is granted by implication or otherwise under any patent or patent rights of STMicroelectronics. Specification mentioned in this publication are subject to change without notice. This publication supersedes and replaces all information previously supplied. STMicroelectronics products are not authorized for use as critical components in life support devices or systems without express written approval of STMicroelectronics.

The ST logo is a trademark of STMicroelectronics

© 1999 STMicroelectronics – Printed in Italy – All Rights Reserved

STMicroelectronics GROUP OF COMPANIES

Australia - Brazil - China - Finland - France - Germany - Hong Kong - India - Italy - Japan - Malaysia - Malta - Morocco -
Singapore - Spain - Sweden - Switzerland - United Kingdom - U.S.A.

<http://www.st.com>