

Car radio signal processor

Features

- 3 Stereo inputs
- 3 Mono inputs
- Dynamic-compression-stage for cd
- Softstep-volume
- Bass, treble and loudness control
- Voice-band-filter
- Direct mute and softmute
- Internal beep
- Four independent speaker-outputs
- Stereo subwoofer output
- Independent second source-selector
- Full mixing capability
- Pause detector

Stereo decoder:

- RDS mute
- No external adjustments
- AM/FM noiseblanker with several trigger controls
- Programmable multipath detector
- Quality detector output

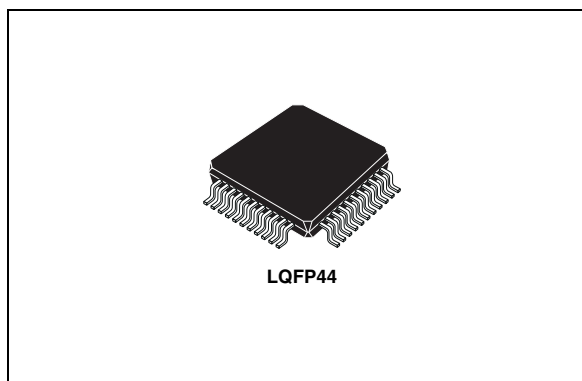

Digital control:

I²C bus interface

Description

The device includes a high performance audioprocessor and a stereo decoder-noise blanker combination, with the whole low frequency signal processing necessary for state of the art, as well as future car radios. The digital control allows a programming in a wide range of all the filter characteristics. The stereo decoder part also offers several possibilities of programming, especially for the adaptation to different IF devices.

Table 1. Device summary

| Part numbers | Package | Packing |
|--------------|------------------------|---------|
| TDA7402 | LQFP44 (10x 10x 1.4mm) | Tube |

Contents

- 1 Pin connections and block diagram 7**
- 2 Electrical specifications 9**
- 3 Audioprocessor part features: 15**
- 4 Audioprocessor part 17**
 - 4.1 Input stages 17
 - 4.1.1 Full-differential stereo Input 1 (FD1) 17
 - 4.1.2 Full-differential stereo Input 2 (FD2) 17
 - 4.1.3 Mono differential Input 1 (MD1) 18
 - 4.1.4 Mono differential Input 2 (MD2) 18
 - 4.1.5 Single ended stereo Input (SE1), single ended mono input (AM) and FM-MPX input 18
 - 4.2 AutoZero 18
 - 4.2.1 AutoZero for stereo decoder selection 18
 - 4.2.2 AutoZero remain 18
 - 4.3 Pause detector / MUX-output 19
 - 4.3.1 Loudness 19
 - 4.3.2 Attenuation 19
 - 4.3.3 Peak frequency 20
 - 4.3.4 Loudness order 20
 - 4.3.5 Flat mode 20
 - 4.4 SoftMute 21
 - 4.5 SoftStep volume 21
 - 4.6 Bass 22
 - 4.6.1 Attenuation 22
 - 4.6.2 Center frequency 22
 - 4.6.3 Quality factors 23
 - 4.6.4 DC mode 23
 - 4.7 Treble 24
 - 4.7.1 Attenuation 24
 - 4.7.2 Center frequency 24
 - 4.8 Subwoofer application 25

| | | |
|----------|---|-----------|
| 4.9 | Voice band application | 25 |
| 4.10 | Compander | 26 |
| 4.10.1 | Anti-clipping | 26 |
| 4.10.2 | Characteristic | 27 |
| 4.10.3 | I ² C bus timing | 27 |
| 4.11 | AC coupling | 28 |
| 4.12 | Output selector | 28 |
| 4.13 | Subwoofer | 29 |
| 4.14 | Speaker attenuator and mixing | 30 |
| 4.15 | Audioprocessor testing | 31 |
| 5 | Stereo decoder part | 32 |
| 5.1 | Features: | 32 |
| 5.2 | Electrical characteristics | 32 |
| 5.3 | Notes about the characteristics | 35 |
| 5.3.1 | Intermodulation suppression | 35 |
| 5.3.2 | Traffic radio (V.F.) suppression | 35 |
| 5.3.3 | SCA (subsidiary communications authorization) | 35 |
| 5.3.4 | ACI (adjacent channel interference) | 36 |
| 5.4 | Noise blanker part | 36 |
| 5.4.1 | Features: | 36 |
| 5.5 | Multipath detector | 39 |
| 5.5.1 | Features: | 39 |
| 6 | Functional description of stereo decoder | 40 |
| 6.1 | Stereo decoder mute | 40 |
| 6.2 | InGain + infilter | 41 |
| 6.3 | Demodulator | 41 |
| 6.4 | De-emphasis and highcut | 42 |
| 6.5 | PLL and pilot tone detector | 42 |
| 6.6 | Field strength control | 42 |
| 6.7 | EVEL input and gain | 42 |
| 6.8 | Stereo blend control | 43 |
| 6.9 | Highcut control | 43 |

| | | |
|-----------|---|-----------|
| 7 | Functional description of the noise blanker | 45 |
| 7.1 | Trigger path FM | 45 |
| 7.2 | Noise controlled threshold adjustment (NCT) | 45 |
| 7.3 | Additional threshold control mechanism | 46 |
| 7.3.1 | Automatic threshold control by the stereo blend voltage | 46 |
| 7.3.2 | Over deviation detector | 46 |
| 7.3.3 | Multipath level | 46 |
| 7.3.4 | AM mode of the noiseblanker | 46 |
| 8 | Functional description of the multipath detector | 47 |
| 8.1 | Quality detector | 47 |
| 8.2 | Testmode | 48 |
| 8.3 | Dual MPX usage | 48 |
| 8.3.1 | Feature description | 48 |
| 8.3.2 | Configuration | 48 |
| 9 | I²C bus interface | 49 |
| 9.1 | Interface protocol | 49 |
| 9.2 | Auto increment | 49 |
| 9.3 | Transmitted data (send mode) | 49 |
| 9.4 | Subaddress (receive mode) | 50 |
| 9.5 | Data byte specification | 51 |
| 10 | Application information | 68 |
| 11 | Package information | 69 |
| 12 | Revision history | 70 |

List of tables

| | | |
|-----------|--|----|
| Table 1. | Device summary | 1 |
| Table 2. | Electrical characteristics | 9 |
| Table 3. | Absolute maximum ratings | 14 |
| Table 4. | Thermal data | 14 |
| Table 5. | Supply | 14 |
| Table 6. | Attack times vs soft-step times | 27 |
| Table 7. | Electrical characteristics | 32 |
| Table 8. | Electrical characteristics | 36 |
| Table 9. | Electrical characteristics of multipath detector | 39 |
| Table 10. | Transmitted data (send mode) | 49 |
| Table 11. | Reset condition | 49 |
| Table 12. | Subaddress (receive mode) | 50 |
| Table 13. | Main selector (0) | 51 |
| Table 14. | Main loudness (1) | 51 |
| Table 15. | Volume (2) | 52 |
| Table 16. | Treble filter (3) | 52 |
| Table 17. | Bass filter (4) | 53 |
| Table 18. | Mixing programming (5) | 53 |
| Table 19. | Soft mute (6) | 54 |
| Table 20. | Voiceband (7) | 54 |
| Table 21. | Second source selector (8) | 55 |
| Table 22. | Second loudness (9) | 56 |
| Table 23. | Subwoofer Configuration / Bass (10) | 56 |
| Table 24. | Compander (11) | 57 |
| Table 25. | Configuration audioprocessor I (12) | 57 |
| Table 26. | Configuration audioprocessor II (13) | 58 |
| Table 27. | Speaker, subwoofer and mixer level-control (14-20) | 59 |
| Table 28. | Testing Audioprocessor (21) | 60 |
| Table 29. | Stereo decoder (22) | 60 |
| Table 30. | Noise blanker I (23) | 61 |
| Table 31. | Noiseblanker II (24) | 62 |
| Table 32. | AM / FM noiseblanker (25) | 62 |
| Table 33. | High cut (26) | 63 |
| Table 34. | Fieldstrength control (27) | 64 |
| Table 35. | Multipath detector (28) | 64 |
| Table 36. | Stereo decoder adjustment (29) | 65 |
| Table 37. | Stereo decoder configuration (30) | 66 |
| Table 38. | Testing stereo decoder (31) | 66 |
| Table 39. | Document revision history | 70 |

List of figures

| | | |
|------------|---|----|
| Figure 1. | PIN connection (top view) | 7 |
| Figure 2. | Block diagram | 8 |
| Figure 3. | Input-stages | 17 |
| Figure 4. | Loudness attenuation @ $f_P = 400\text{Hz}$ | 19 |
| Figure 5. | Loudness center frequencies @ Attn. = 15dB. | 20 |
| Figure 6. | 1st and 2nd order loudness @ Attn. = 15dB, $f_P=400\text{Hz}$ | 20 |
| Figure 7. | Softmute timing | 21 |
| Figure 8. | SoftStep timing | 21 |
| Figure 9. | Bass control @ $f_C = 80\text{Hz}$, $Q = 1$ | 22 |
| Figure 10. | Bass center frequencies @ gain = 14dB, $Q = 1$ | 22 |
| Figure 11. | Bass Quality factors @ Gain = 14dB, $f_C = 80\text{Hz}$ | 23 |
| Figure 12. | Bass normal and DC Mode @ Gain = 14dB, $f_C = 80\text{Hz}$ | 23 |
| Figure 13. | Treble Control @ $f_C = 17.5\text{kHz}$ | 24 |
| Figure 14. | Treble center frequencies @ gain = 14dB | 24 |
| Figure 15. | Subwoofer application with LPF 80/120/160Hz and HPF 90/135/180Hz | 25 |
| Figure 16. | Voiceband application with HPF 300/450/600/750Hz and LPF 3k/6kHz | 25 |
| Figure 17. | Compander block diagram | 26 |
| Figure 18. | Compander characteristic. | 27 |
| Figure 19. | Output selector | 28 |
| Figure 20. | Application 1 using internal highpass and mono low pass filter | 29 |
| Figure 21. | Application 2 using internal highpass and external stereo low pass filter | 30 |
| Figure 22. | Application 3 using pure external filtering (e.g. DSP) | 30 |
| Figure 23. | Output selector | 31 |
| Figure 24. | Vn timing diagram | 38 |
| Figure 25. | Trigger threshold vs. VPEAK | 38 |
| Figure 26. | Deviation controlled trigger adjustment | 38 |
| Figure 27. | Field strength controlled trigger adjustment | 38 |
| Figure 28. | Block diagram of stereo decoder | 40 |
| Figure 29. | Signals during stereo decoder's SoftMute | 41 |
| Figure 30. | Signal control via SoftMute pin | 41 |
| Figure 31. | Internal stereo blend characteristics | 43 |
| Figure 32. | Relation between internal and external LEVEL voltages for setup of stereo blend | 43 |
| Figure 33. | Highcut characteristics | 44 |
| Figure 34. | Block diagram of the noise blanker. | 45 |
| Figure 35. | Block diagram of the multipath detector | 47 |
| Figure 36. | Dual MPX input diagram. | 48 |
| Figure 37. | Application diagram (standard configuration) | 68 |
| Figure 38. | Application diagram (Dual MPX mode). | 68 |
| Figure 39. | LQFP44 (10x10) Mechanical data and package dimensions | 69 |

1 Pin connections and block diagram

Figure 1. PIN connection (top view)

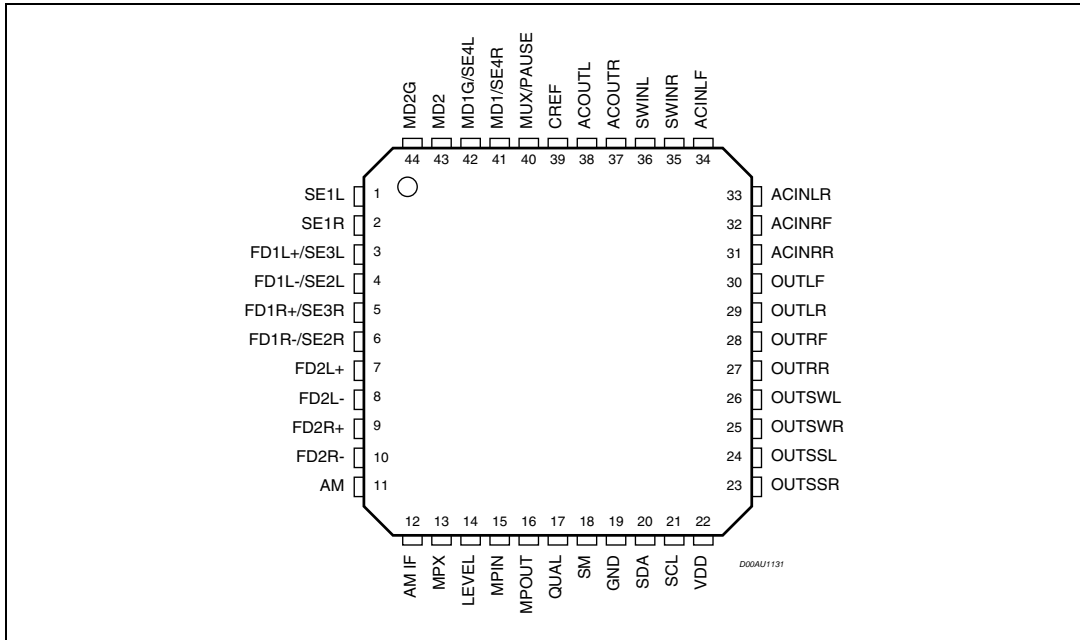
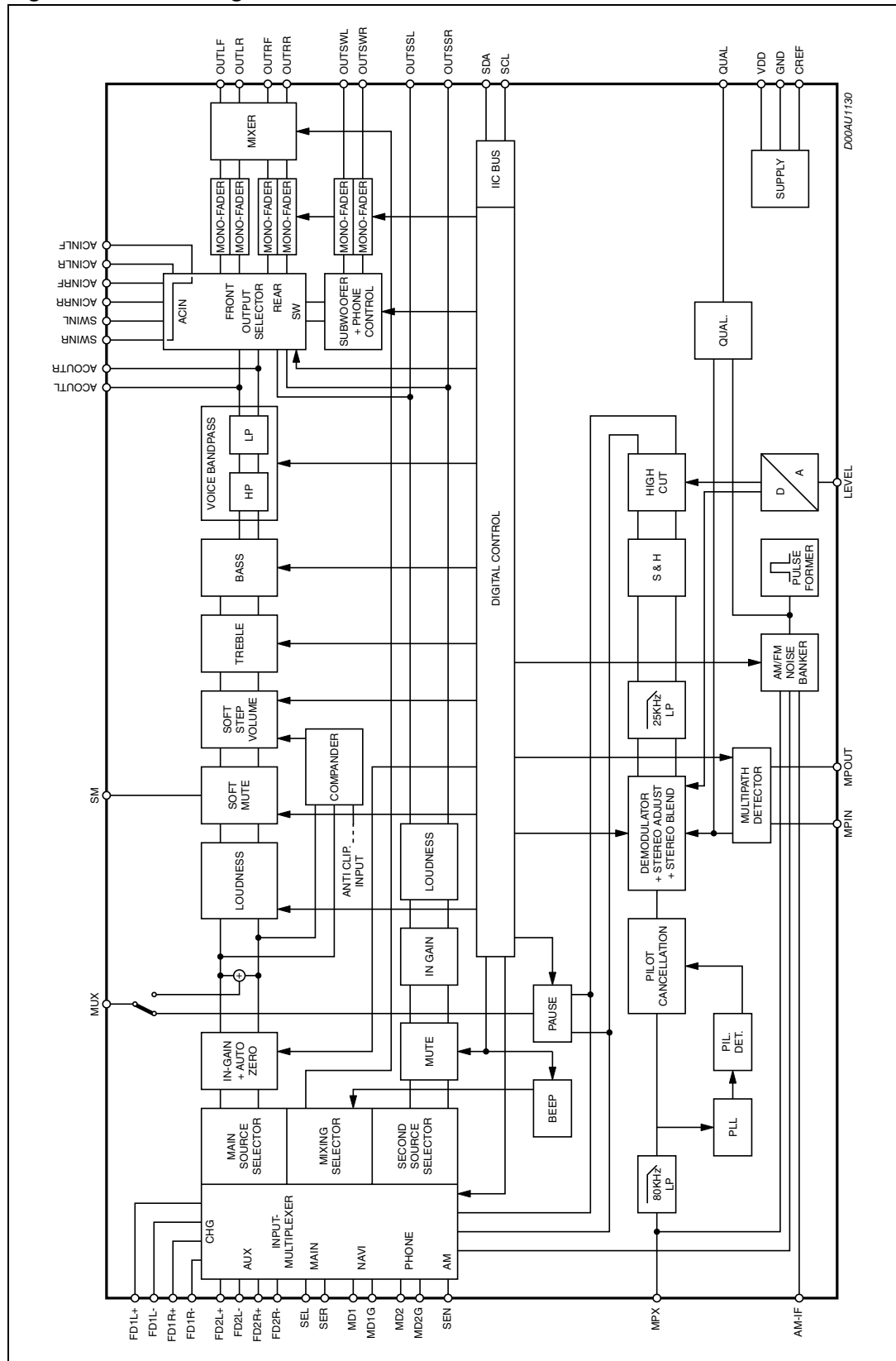

Figure 2. Block diagram



2 Electrical specifications

$V_S = 9V$; $T_{amb} = 25^\circ C$; $R_L = 10k\Omega$; all gains = 0dB; $f = 1kHz$; unless otherwise specified

Table 2. Electrical characteristics

| Symbol | Parameter | Test condition | Min. | Typ. | Max. | Unit |
|-----------------------------------|---|------------------------------------|------|------|------|-----------|
| Input selector | | | | | | |
| R_{in} | Input resistance | all single ended Inputs | 70 | 100 | 130 | $k\Omega$ |
| V_{CL} | Clipping level | | 2.2 | 2.6 | | V_{RMS} |
| S_{IN} | Input separation | | 80 | 100 | | dB |
| $G_{IN MIN}$ | Min. input gain | | -1 | 0 | +1 | dB |
| $G_{IN MAX}$ | Max. input gain | | 13 | 15 | 17 | dB |
| G_{STEP} | Step resolution | | 0.5 | 1 | 1.5 | dB |
| V_{DC} | DC steps | Adjacent gain steps | -5 | 1 | 5 | mV |
| | | G_{MIN} to G_{MAX} | -10 | 6 | 10 | mV |
| V_{offset} | Remaining offset with autozero | | | 0.5 | | mV |
| Differential stereo inputs | | | | | | |
| R_{in} | Input resistance (see Figure 3) | Differential | 70 | 100 | 130 | $k\Omega$ |
| G_{CD} | Gain | only at true differential input | -1 | 0 | 1 | dB |
| | | | -5 | -6 | 7 | dB |
| | | | -11 | -12 | -13 | dB |
| CMRR | Common mode rejection ratio | $V_{CM} = 1V_{RMS} @ 1kHz$ | 46 | 70 | | dB |
| | | $V_{CM} = 1V_{RMS} @ 10kHz$ | 46 | 60 | | dB |
| e_{NO} | Output-noise @ speaker outputs | 20Hz - 20kHz, flat; all stages 0dB | | 9 | 15 | μV |
| Differential mono inputs | | | | | | |
| R_{in} | Input impedance | Differential | 40 | 56 | 72 | $k\Omega$ |
| CMRR | Common mode rejection ratio | $V_{CM} = 1V_{RMS} @ 1kHz$ | 40 | 70 | | dB |
| | | $V_{CM} = 1V_{RMS} @ 10kHz$ | 40 | 60 | | dB |
| Beep control | | | | | | |
| V_{RMS} | Beep level | Mix-gain = 6dB | 250 | 350 | 500 | mV |
| f_{Beep} | Beep frequency | f_{Beep1} | 570 | 600 | 630 | Hz |
| | | f_{Beep2} | 740 | 780 | 820 | Hz |
| | | f_{Beep1} | 1.48 | 1.56 | 1.64 | kHz |
| | | f_{Beep1} | 2.28 | 2.4 | 2.52 | kHz |

Table 2. Electrical characteristics (continued)

| Symbol | Parameter | Test condition | Min. | Typ. | Max. | Unit |
|--|---|------------------------------|-------|-------|-------|------|
| Mixing control | | | | | | |
| M _{LEVEL} | Mixing ratio | Main / mix source | | -6/-6 | | dB |
| G _{MAX} | Max. gain | | 13 | 15 | 17 | dB |
| A _{MAX} | Max. attenuation | | -83 | -79 | -75 | dB |
| A _{STEP} | Attenuation step | | 0.5 | 1 | 1.5 | dB |
| Multiplexer output ⁽¹⁾ | | | | | | |
| R _{OUT} | Output impedance | | | 225 | 300 | W |
| R _L | Output load resistance | | 2 | | | kΩ |
| C _L | Output load capacitance | | | | 10 | nF |
| V _{DC} | DC voltage level | | 4.3 | 4.5 | 4.7 | V |
| Loudness control | | | | | | |
| A _{STEP} | Step resolution | | 0.5 | 1 | 1.5 | dB |
| A _{MAX} | Max. attenuation | | -21 | -19 | -17 | dB |
| f _{Peak} | Peak frequency | f _{P1} | 180 | 200 | 220 | Hz |
| | | f _{P2} | 360 | 400 | 440 | Hz |
| | | f _{P3} | 540 | 600 | 660 | Hz |
| | | f _{P4} | 720 | 800 | 880 | Hz |
| Volume control | | | | | | |
| G _{MAX} | Max. gain | | 30 | 32 | 34 | dB |
| A _{MAX} | Max. attenuation | | -83 | -79.5 | -75 | dB |
| A _{STEP} | Step resolution | | 0 | 0.5 | 1 | dB |
| E _A | Attenuation set error | G = -20 to +20dB | -0.75 | 0 | +0.75 | dB |
| | | G = -80 to -20dB | -4 | 0 | 3 | dB |
| E _T | Tracking error | | | | 2 | dB |
| V _{DC} | DC steps | Adjacent attenuation steps | | 0.1 | 3 | mV |
| | | From 0dB to G _{MIN} | | 0.5 | 5 | mV |
| Soft mute | | | | | | |
| A _{MUTE} | Mute attenuation | | 80 | 100 | | dB |
| T _D | Delay time | T1 | | 0.48 | 1 | ms |
| | | T2 | | 0.96 | 2 | ms |
| | | T3 | 70 | 123 | 170 | ms |
| | | T4 | 200 | 324 | 600 | ms |
| V _{TH low} | Low threshold for SM Pin ⁽²⁾ | | | | 1 | V |

Table 2. Electrical characteristics (continued)

| Symbol | Parameter | Test condition | Min. | Typ. | Max. | Unit |
|-------------------------------------|---------------------------|----------------|----------|----------|----------|-----------|
| $V_{TH\ high}$ | High threshold for SM Pin | | 2.5 | | | V |
| R_{PU} | Internal pull-up resistor | | 32 | 45 | 58 | $k\Omega$ |
| V_{PU} | Internal pull-up voltage | | | 3.3 | | V |
| Bass control | | | | | | |
| C_{RANGE} | Control range | | ± 14 | ± 15 | ± 16 | dB |
| A_{STEP} | Step resolution | | 0.5 | 1 | 1.5 | dB |
| f_C | Center frequency | f_{C1} | 54 | 60 | 66 | Hz |
| | | f_{C2} | 63 | 70 | 77 | Hz |
| | | f_{C3} | 72 | 80 | 88 | Hz |
| | | f_{C4} | 81 | 90 | 99 | Hz |
| | | f_{C5} | 90 | 100 | 110 | Hz |
| | | f_{C6} | 117 | 130 | 143 | Hz |
| | | f_{C7} | 135 | 150 | 165 | Hz |
| | | f_{C8} | 180 | 200 | 220 | Hz |
| Q_{BASS} | Quality factor | Q_1 | 0.9 | 1 | 1.1 | |
| | | Q_2 | 1.1 | 1.25 | 1.4 | |
| | | Q_3 | 1.3 | 1.5 | 1.7 | |
| | | Q_4 | 1.8 | 2 | 2.2 | |
| DC_{GAIN} | Bass-DC-gain | DC = off | -1 | 0 | +1 | dB |
| | | DC = on | 4 | 4.4 | 6 | dB |
| Treble control | | | | | | |
| C_{RANGE} | Control range | | ± 14 | ± 15 | ± 16 | dB |
| A_{STEP} | Step resolution | | 0.5 | 1 | 1.5 | dB |
| f_C | Center frequency | f_{C1} | 8 | 10 | 12 | kHz |
| | | f_{C2} | 10 | 12.5 | 15 | kHz |
| | | f_{C3} | 12 | 15 | 18 | kHz |
| | | f_{C4} | 14 | 17.5 | 21 | kHz |
| Pause detector⁽³⁾ | | | | | | |
| V_{TH} | Zero crossing threshold | Window 1 | | 40 | | mV |
| | | Window 2 | | 80 | | mV |
| | | Window 3 | | 160 | | mV |
| I_{DELAY} | Pull-up current | | 15 | 25 | 35 | μA |
| V_{THP} | Pause threshold | | | 3.0 | | V |

Table 2. Electrical characteristics (continued)

| Symbol | Parameter | Test condition | Min. | Typ. | Max. | Unit |
|------------------------------|---------------------------|----------------------------|------|------|------|-----------|
| Speaker attenuators | | | | | | |
| R_{in} | Input impedance | | 35 | 50 | 65 | $k\Omega$ |
| G_{MAX} | Max. gain | | 14 | 15 | 16 | dB |
| A_{MAX} | Max. attenuation | | -83 | -79 | -75 | dB |
| A_{STEP} | Step resolution | | 0.5 | 1 | 1.5 | dB |
| A_{MUTE} | Output mute attenuation | | 80 | 90 | | dB |
| E_E | Attenuation set error | | | | 2 | dB |
| V_{DC} | DC steps | Adjacent attenuation steps | | 0.1 | 5 | mV |
| Audio outputs | | | | | | |
| V_{CLIP} | Clipping level | $d = 0.3\%$ | 2.2 | 2.6 | | V_{RMS} |
| R_L | Output load resistance | | 2 | | | $k\Omega$ |
| C_L | Output load capacitance | | | | 10 | nF |
| R_{OUT} | Output impedance | | | 30 | 100 | W |
| V_{DC} | DC voltage level | | 4.3 | 4.5 | 4.7 | V |
| Voice bandpass | | | | | | |
| f_{HP} | Highpass corner frequency | f_{HP1} | 81 | 90 | 99 | Hz |
| | | f_{HP2} | 122 | 135 | 148 | Hz |
| | | f_{HP3} | 162 | 180 | 198 | Hz |
| | | f_{HP4} | 194 | 215 | 236 | Hz |
| | | f_{HP5} | 270 | 300 | 330 | Hz |
| | | f_{HP6} | 405 | 450 | 495 | Hz |
| | | f_{HP7} | 540 | 600 | 660 | Hz |
| | | f_{HP8} | 675 | 750 | 825 | Hz |
| f_{LP} | Lowpass corner frequency | f_{LP1} | 2.7 | 3 | 3.3 | kHz |
| | | f_{LP2} | 5.4 | 6 | 6.6 | kHz |
| Subwoofer attenuators | | | | | | |
| R_{in} | Input impedance | | 35 | 50 | 65 | $k\Omega$ |
| G_{MAX} | Max. gain | | 14 | 15 | 16 | dB |
| A_{ATTN} | Max. attenuation | | -83 | -79 | -75 | dB |
| A_{STEP} | Step resolution | | 0.5 | 1 | 1.5 | dB |
| A_{MUTE} | Output mute attenuation | | 80 | 90 | | dB |
| E_E | Attenuation set error | | | | 2 | dB |
| V_{DC} | DC steps | Adjacent attenuation steps | | 1 | 5 | mV |

Table 2. Electrical characteristics (continued)

| Symbol | Parameter | Test condition | Min. | Typ. | Max. | Unit |
|---|--|--|------|------|------|------------------|
| Subwoofer lowpass | | | | | | |
| f_{LP} | Lowpass corner frequency | f_{LP1} | 72 | 80 | 88 | Hz |
| | | f_{LP2} | 108 | 120 | 132 | Hz |
| | | f_{LP3} | 144 | 160 | 176 | Hz |
| Differential outputs⁽⁴⁾ | | | | | | |
| R_L | load resistance at each output | 1V _{RMS} ; AC coupled; THD=1% | 1 | | | k Ω |
| | | 2V _{RMS} ; AC coupled; THD=1% | 2 | | | k Ω |
| R_{DL} | load resistance differential | 1V _{RMS} ; AC coupled; THD=1% | 2 | | | k Ω |
| | | 2V _{RMS} ; AC coupled; THD=1% | 4 | | | k Ω |
| C_{LMAX} | Capacitive load at each output | C_{Lmax} at each output to ground | | | 10 | nF |
| C_{DLMAX} | Capacitive load differential | C_{Lmax} between output terminals | | | 5 | nF |
| V_{Offset} | DC offset at pins | Output muted | -10 | | 10 | mV |
| R_{OUT} | Output impedance | | | 30 | 100 | W |
| V_{DC} | DC voltage level | | 4.3 | 4.5 | 4.7 | V |
| e_{NO} | Output noise | Output muted | | 6 | 15 | μ V |
| Compander | | | | | | |
| G_{MAX} | max. compander gain | $V_i < -46$ dB | | 19 | | dB |
| | | $V_i < -46$ dB, Anti-clip = on | | 29 | | dB |
| t_{Att} | Attack time | t_{Att1} | | 6 | | ms |
| | | t_{Att2} | | 12 | | ms |
| | | t_{Att3} | | 24 | | ms |
| | | t_{Att4} | | 49 | | ms |
| t_{Rel} | Release time | t_{Rel1} | | 390 | | ms |
| | | t_{Rel2} | | 780 | | ms |
| | | t_{Rel3} | | 1.17 | | s |
| | | t_{Rel4} | | 1.56 | | s |
| V_{REF} | Compander reference input-level (equals 0dB) | V_{REF1} | | 0.5 | | V _{RMS} |
| | | V_{REF2} | | 1.0 | | V _{RMS} |
| | | V_{REF3} | | 2.0 | | V _{RMS} |
| C_F | Compression factor | Output signal / input signal | | 0.5 | | |
| General | | | | | | |

Table 2. Electrical characteristics (continued)

| Symbol | Parameter | Test condition | Min. | Typ. | Max. | Unit |
|----------|-------------------------------|---|------|---------|----------|--------------------|
| e_{NO} | Output noise | BW = 20Hz - 20kHz output muted all gains = 0dB single ended inputs | | 3 10 | 15 20 | μV μV |
| S/N | Signal to noise ratio | all gains = 0dB flat; $V_O = 2V_{RMS}$ | | 106 | | dB |
| | | bass, treble at +12dB; a-weighted; $V_O = 2.6V_{RMS}$ | | 100 | | dB |
| d | distortion | $V_{IN} = 1V_{RMS}$; all stages 0dB | | 0.005 | 0.1 | % |
| | | $V_{OUT} = 1V_{RMS}$; bass & treble = 12dB | | 0.05 | 0.1 | % |
| S_C | Channel separation left/right | | 80 | 100 | | dB |
| E_T | Total tracking error | $A_V = 0$ to -20dB | -1 | 0 | 1 | dB |
| | | $A_V = -20$ to -60dB | -2 | 0 | 2 | dB |

1. If configured as multiplexer-output
2. The SM Pin is active low (mute = 0)
3. If configured as pause-output
4. If programmed as subwoofer diff. output

Table 3. Absolute maximum ratings

| Symbol | Parameter | Value | Unit |
|-----------|----------------------------------|-------------|-------------|
| V_S | Operating supply voltage | 10.5 | V |
| T_{amb} | Operating temperature range | -40 to 85 | $^{\circ}C$ |
| T_{stg} | Storage temperature range | -55 to +150 | $^{\circ}C$ |
| V_{ESD} | ESD protection (human body mode) | ± 2000 | V |
| V_{ESD} | ESD protection (machine mode) | ± 200 | V |

Table 4. Thermal data

| Symbol | Parameter | Value | Unit |
|------------------|--------------------------------------|-------|---------------|
| $R_{th\ j-pins}$ | Thermal resistance junction-pins max | 65 | $^{\circ}C/W$ |

Table 5. Supply

| Symbol | Parameter | Test condition | Min. | Typ. | Max. | Unit |
|--------|-------------------------|--------------------------------------|------|------|------|------|
| V_S | Supply voltage | | 7.5 | 9 | 10 | V |
| I_S | Supply current | $V_S = 9V$ | 35 | 50 | 65 | mA |
| SVRR | Ripple rejection @ 1kHz | Audioprocessor (all Filters flat) | | 60 | | dB |

3 Audioprocessor part features:

- Input multiplexer
 - 2 fully differential CD stereo inputs with programmable attenuation
 - 1 single ended stereo input
 - 2 differential mono input
 - 1 single ended mono input
 - In-gain 0..15dB, 1dB steps
 - internal offset cancellation (AutoZero)
 - separate second source selector
- Beep
 - internal beep with 4 frequencies
- Mixing stage
 - Beep, phone and navigation mixable to all speaker outputs
- Loudness
 - programmable center frequency and frequency response
 - 15 x 1dB steps
 - selectable flat-mode (constant attenuation)
- Volume
 - 0.5dB attenuator
 - 100dB range
 - soft-step control with programmable times
- Comander
 - dynamic range compression for use with CD
 - 2:1 compression rate
 - programmable max. gain
- Bass
 - 2nd order frequency response
 - center frequency programmable in 8 steps
 - DC gain programmable
 - ± 15 x 1dB steps
- Treble
 - 2nd order frequency response
 - center frequency programmable in 4 steps
 - ± 15 x 1dB steps
- Voice Bandpass
 - 2nd order butterworth highpass filter with programmable cut off frequency
 - 2nd order butterworth lowpass filter with programmable cut off frequency
 - selectable flat mode
 -

- Speaker
 - 4 independent speaker controls in 1dB steps
 - control range 95dB
 - separate Mute
- Subwoofer
 - single ended stereo output
 - independent stereo level controls in 1dB steps
 - control range 95dB
 - separate Mute
- Mute Functions
 - direct mute
 - digitally controlled SoftMute with 4 programmable mute-times
- Pause Detector
 - programmable threshold

4 Audioprocessor part

4.1 Input stages

In the basic configuration two full differential, two mono differential, one single ended stereo and one single ended mono input are available. In addition a dedicated input for the stereo decoder MPX signal is present.

Figure 3. Input-stages

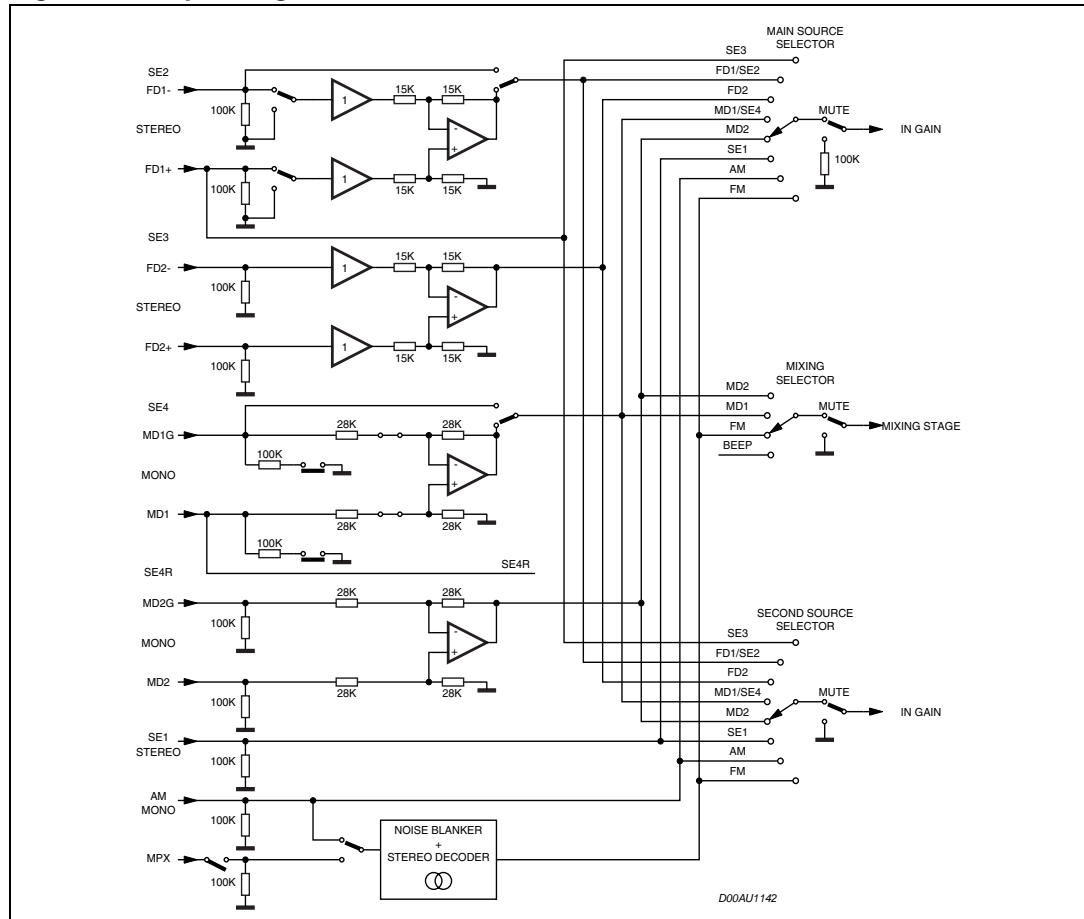

4.1.1 Full-differential stereo Input 1 (FD1)

The FD1 input is implemented as a buffered full-differential stereo stage with 100kΩ input impedance at each input. The attenuation is programmable in 3 steps from 0 to -12dB in order to adapt the incoming signal level. A 6dB attenuation is included in the differential stage, the additional 6dB are done by a following resistive divider. This input is also configurable as two single ended stereo inputs (see pin-out).

4.1.2 Full-differential stereo Input 2 (FD2)

The FD2 input has the same general structure as FD1, but with a programmable attenuation of 0 or 6dB embedded in the differential stage.

4.1.3 Mono differential Input 1 (MD1)

The MD1 input is designed as a basic differential stage with 56k Ω input impedance. This input is configurable as a single ended stereo input (see pin-out).

4.1.4 Mono differential Input 2 (MD2)

The MD2 input has the same topology as MD1, but without the possibility to configure it to single ended.

4.1.5 Single ended stereo Input (SE1), single ended mono input (AM) and FM-MPX input

All single ended inputs offer an input impedance of 100k Ω . The AM pin can be connected by software to the input of the stereo-decoder in order to use the AM noiseblanker and AM High Cut feature.

4.2 AutoZero

The AutoZero allows a reduction of the number of pins as well as external components by canceling any offset generated by or before the In-Gain-stage (Please notice that externally generated offsets, e.g. generated through the leakage current of the coupling capacitors, are not canceled).

The auto zeroing is started every time the DATA-BYTE 0 is selected and needs max. **0.3ms** for the alignment. To avoid audible clicks the Audioprocessor is muted before the loudness stage during this time. The AutoZero feature is only present in the main signal path.

4.2.1 AutoZero for stereo decoder selection

A special procedure is recommended for selecting the stereo decoder at the **main** input-selector to guarantee an optimum offset cancellation:

1. SoftMute or Mute the signal-path
2. Temporary deselect the stereo decoder at all input selectors
3. Configure the stereo decoder via IIC-Bus
4. Wait 1ms
5. Select the stereo decoder at the main input selector first

The root cause of this procedure is, that after muting the stereo decoder (Step 1), the internal stereo decoder filters have to settle in order to perform a proper offset cancellation.

4.2.2 AutoZero remain

In some cases, for example if the μ P is executing a refresh cycle of the I²C Bus programming, it is not useful to start a new AutoZero action because no new source is selected and an undesired mute would appear at the outputs. For such applications the A619 could be switched in the **AutoZero Remain Mode** (Bit 6 of the subaddress byte). If this bit is set to high, the DATABYTE 0 could be loaded without invoking the AutoZero and the old adjustment value remains.

4.3 Pause detector / MUX-output

The pin number 40 (Pause/MUX) is configurable for two different functions:

1. During pause detector OFF this pin is used as a mono output of the main input selector. This signal is often used to drive a level/equalizer display on the car radio front panel.
2. During pause detector ON the pin is used to define the time constant of the detector by an external capacitor. The pause detector is driven by the internal stereo decoder outputs in order to use pauses in the FM signal for alternate frequency jumps. If the signal level of both stereo decoder channels is outside the programmed voltage window, the external capacitor is abruptly discharged. Inside the pause condition the capacitor is slowly recharged by a constant current of $25\mu\text{A}$. The pause information is also available via I²C Bus (see I²C Bus programming).

4.3.1 Loudness

There are four parameters programmable in the loudness stage:

4.3.2 Attenuation

Figure 4 shows the attenuation as a function of frequency at $f_p = 400\text{Hz}$

Figure 4. Loudness attenuation @ $f_p = 400\text{Hz}$.

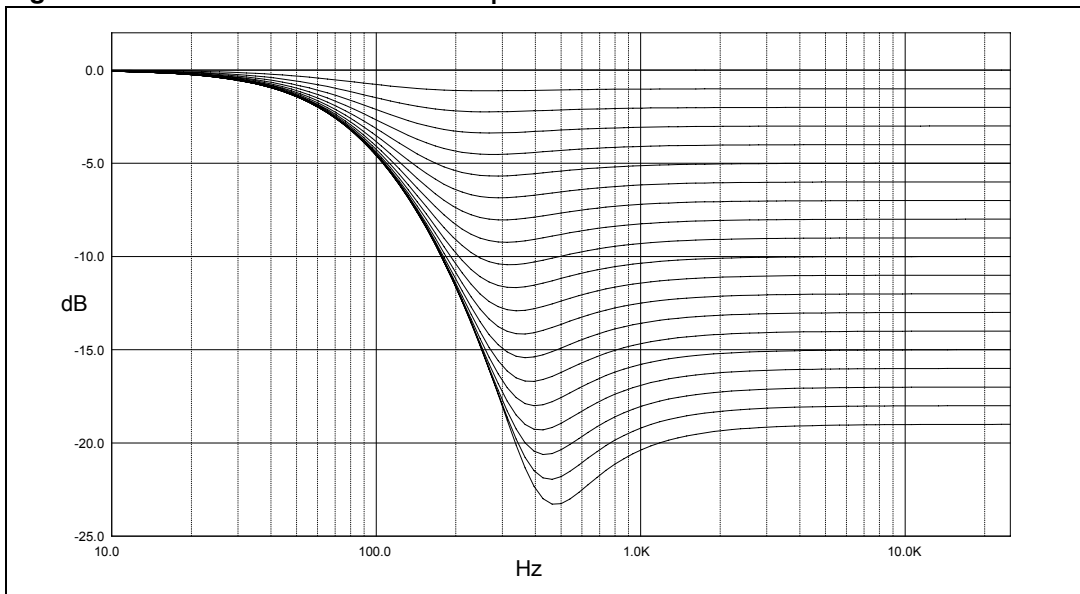

4.3.3 Peak frequency

Figure 5 shows the four possible peak-frequencies at 200, 400, 600 and 800Hz

Figure 5. Loudness center frequencies @ Attn. = 15dB.

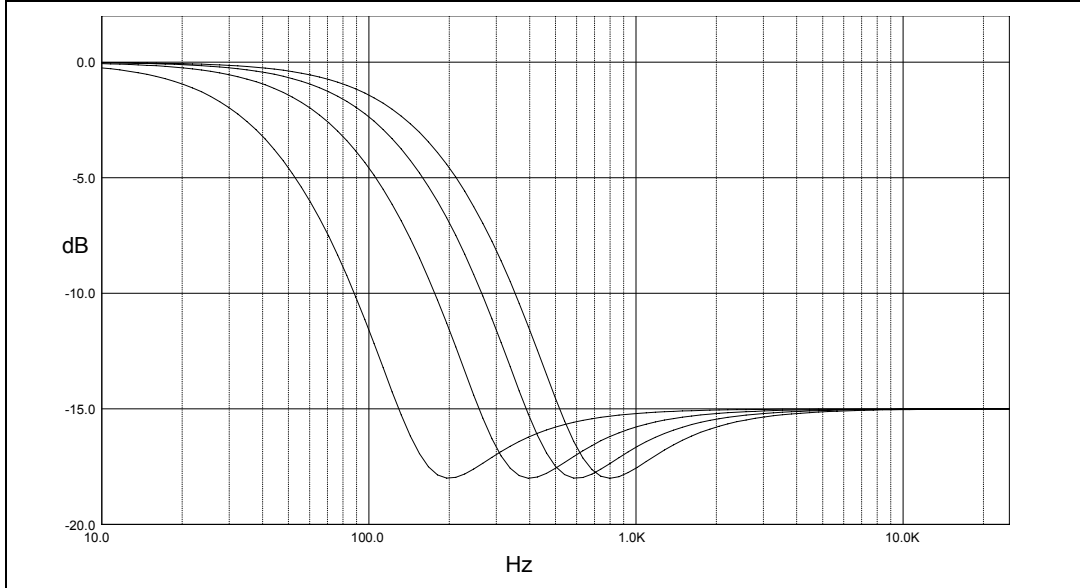

4.3.4 Loudness order

Different shapes of 1st and 2nd-order loudness

Figure 6. 1st and 2nd order loudness @ Attn. = 15dB, $f_p=400\text{Hz}$

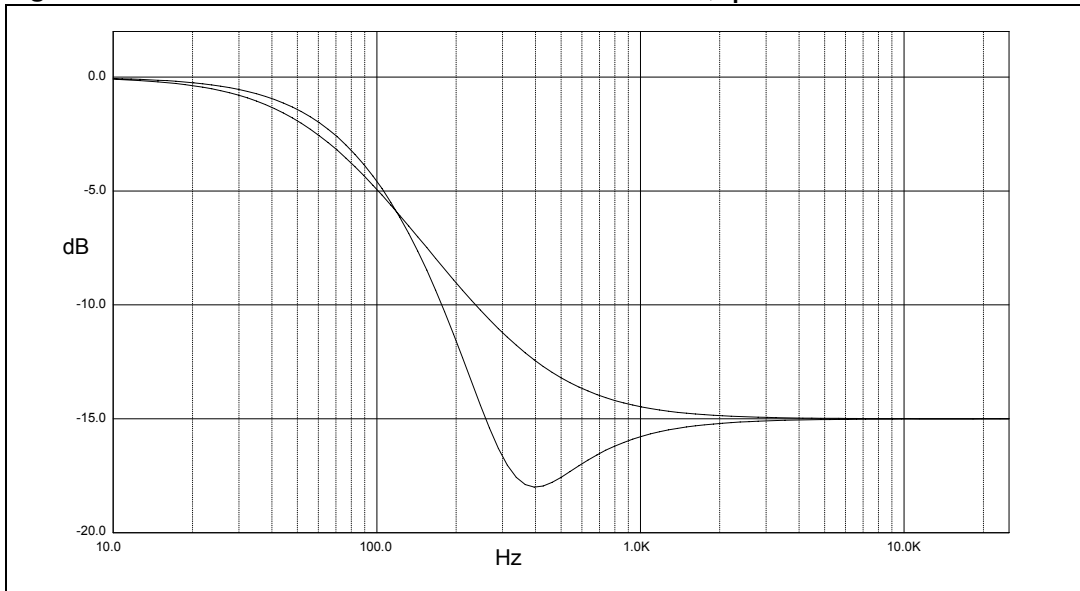

4.3.5 Flat mode

In flat mode the loudness stage works as a 0dB to -19dB attenuator.

4.4 SoftMute

The digitally controlled SoftMute stage allows muting/demuting the signal with a I²C bus programmable slope. The mute process can either be activated by the SoftMute pin or by the I²C-bus. This slope is realized in a special S-shaped curve to mute slow in the critical regions (see [Figure 7](#)).

For timing purposes the Bit0 of the I²C bus output register is set to 1 from the start of muting until the end of de-muting.

Figure 7. Softmute timing

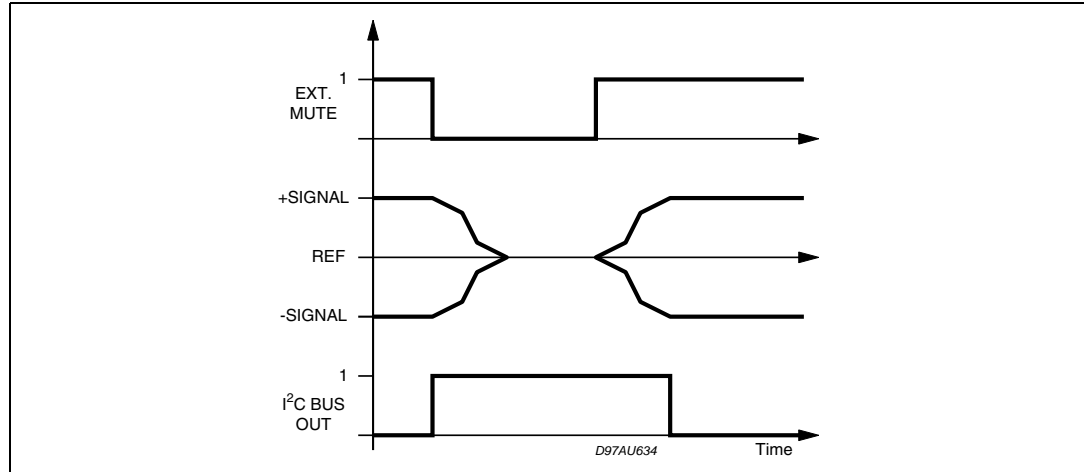

Note: Please notice that a started mute action is always terminated and could not be interrupted by a change of the mute -signal.

4.5 SoftStep volume

When the volume level is changed audible clicks could appear at the output. The root cause of those clicks could either be a DC offset before the volume stage or the sudden change of the envelope of the audiosignal. With the SoftStep feature both kinds of clicks could be reduced to a minimum and are no more audible. The blend time from one step to the next is programmable in four steps.

Figure 8. SoftStep timing

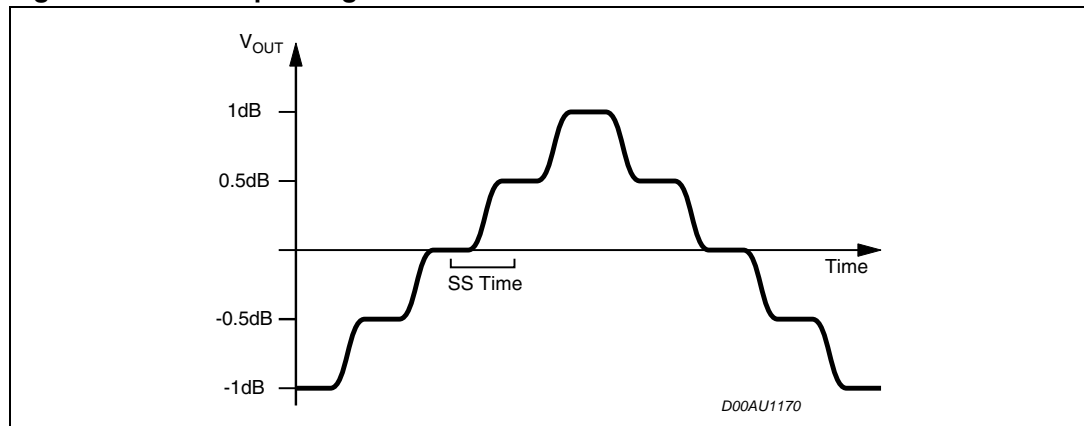

Note: For steps more than 0.5dB the SoftStep mode should be deactivated because it could generate a hard 1dB step during the blend time.

4.6 Bass

There are four parameters programmable in the bass stage:

4.6.1 Attenuation

Figure 9 shows the attenuation as a function of frequency at a center frequency of 80Hz.

Figure 9. Bass control @ $f_c = 80\text{Hz}$, $Q = 1$

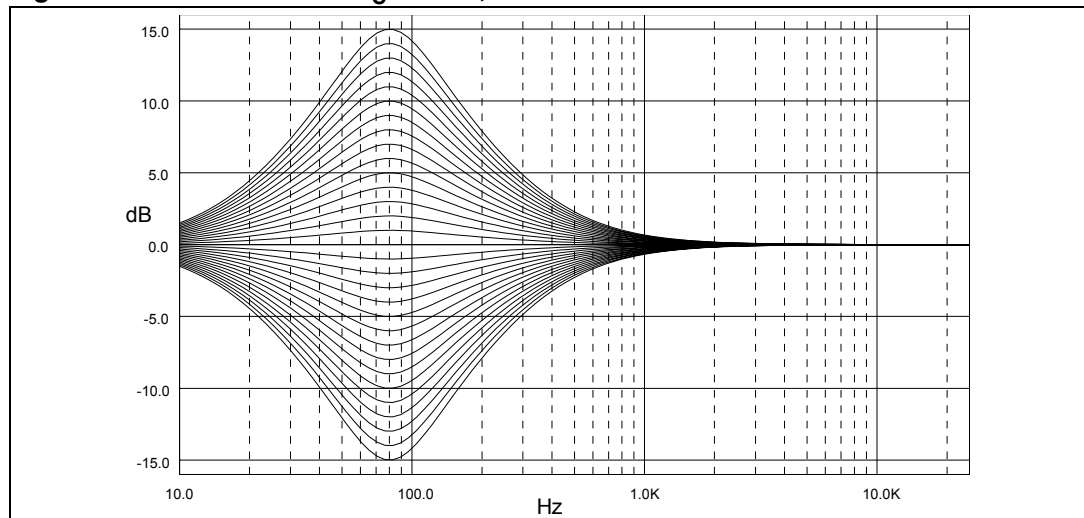

4.6.2 Center frequency

Figure 10 shows the eight possible center frequencies 60, 70, 80, 90, 100, 130, 150 and 200Hz.

Figure 10. Bass center frequencies @ gain = 14dB, $Q = 1$

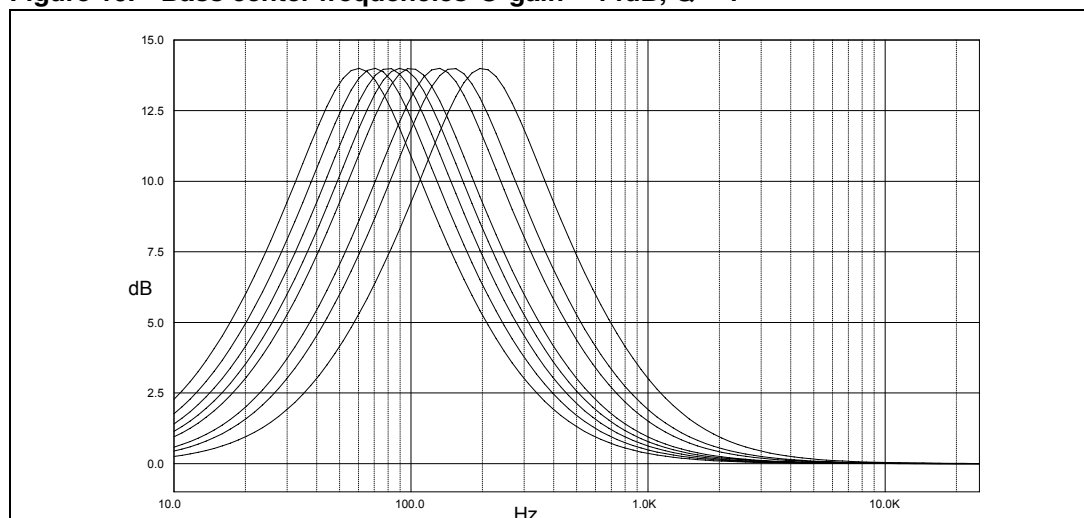

4.6.3 Quality factors

Figure 11 shows the four possible quality factors 1, 1.25, 1.5 and 2.

Figure 11. Bass Quality factors @ Gain = 14dB, $f_c = 80\text{Hz}$

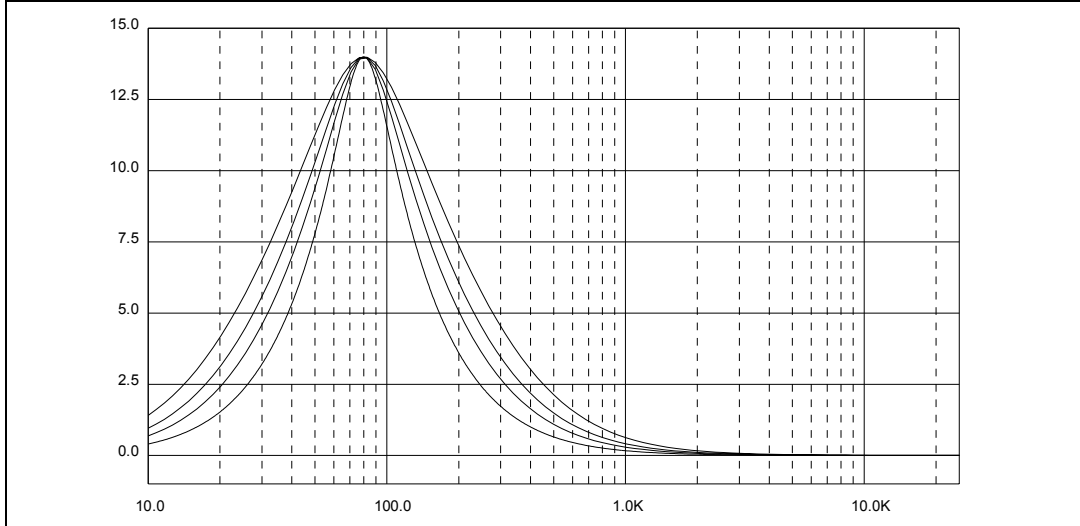

4.6.4 DC mode

In this mode the DC-gain is increased by 4.4dB. In addition the programmed center frequency and quality factor is decreased by 25% which can be used to reach alternative center frequencies or quality factors.

Figure 12. Bass normal and DC Mode @ Gain = 14dB, $f_c = 80\text{Hz}$

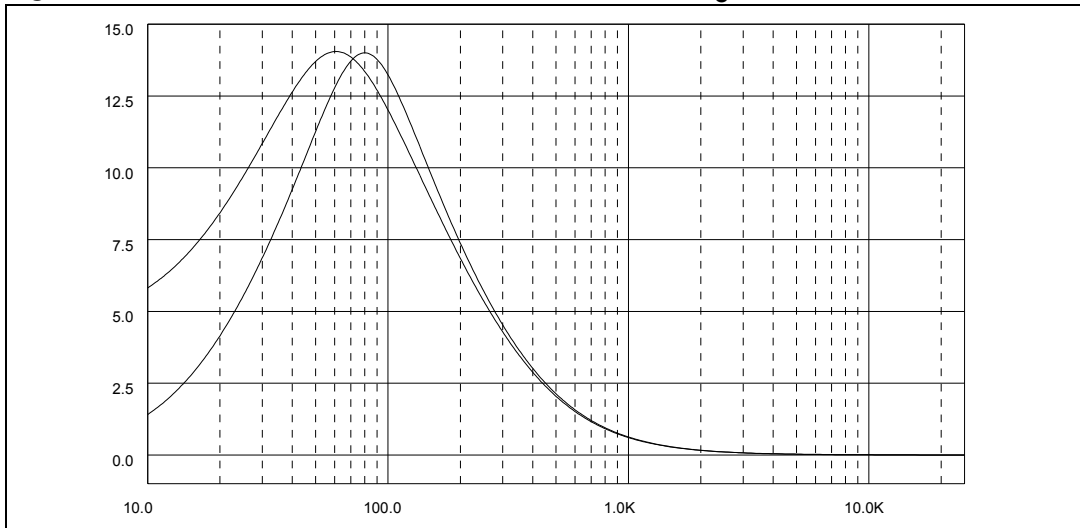

Note: The center frequency, Q and DC-mode can be set fully independently.

4.7 Treble

There are two parameters programmable in the treble stage:

4.7.1 Attenuation

Figure 13. shows the attenuation as a function of frequency at a center frequency of 17.5kHz.

Figure 13. Treble Control @ $f_c = 17.5\text{kHz}$

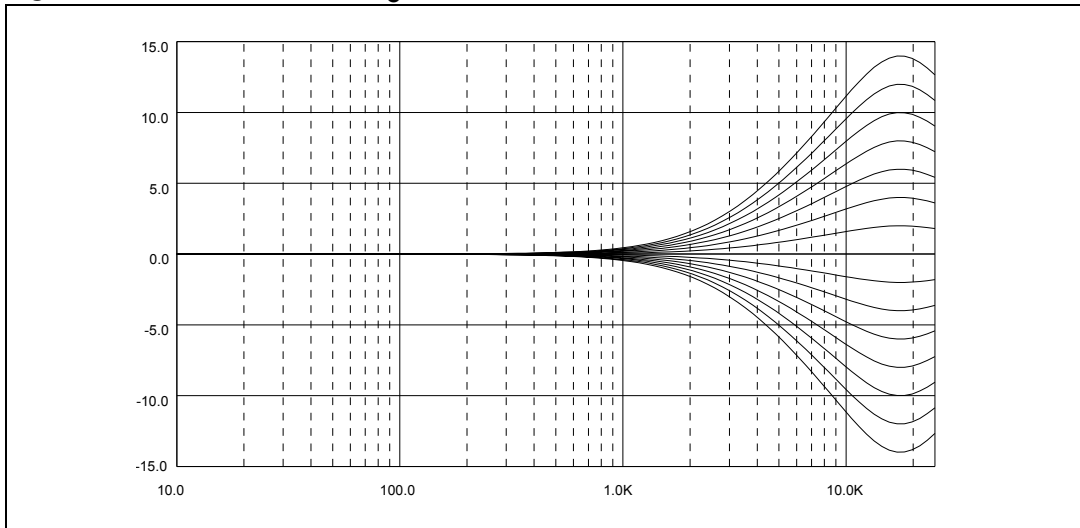

4.7.2 Center frequency

Figure 14. shows the four possible center frequencies 10k, 12.5k, 15k and 17.5kHz.

Figure 14. Treble center frequencies @ gain = 14dB

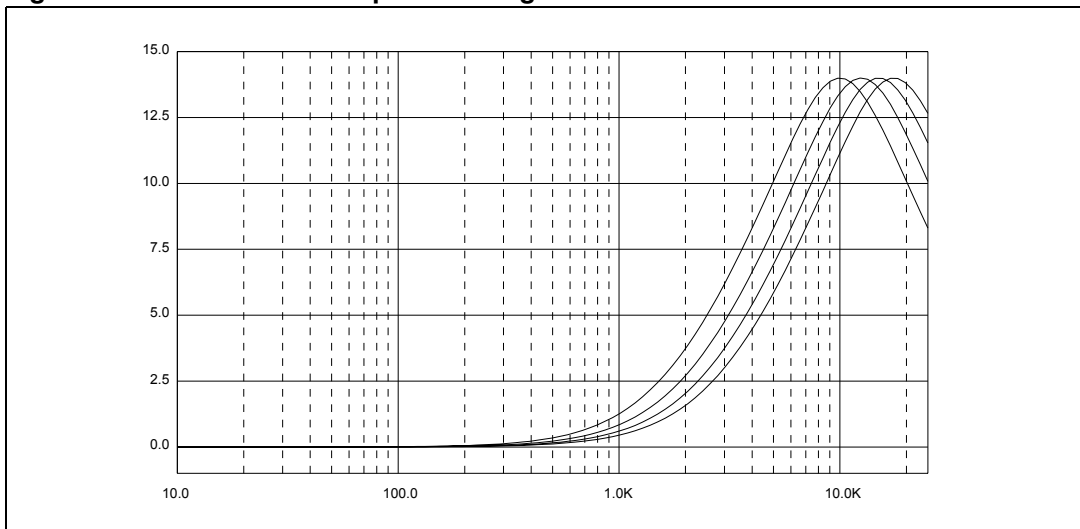

4.8 Subwoofer application

Figure 15. Subwoofer application with LPF 80/120/160Hz and HPF 90/135/180Hz

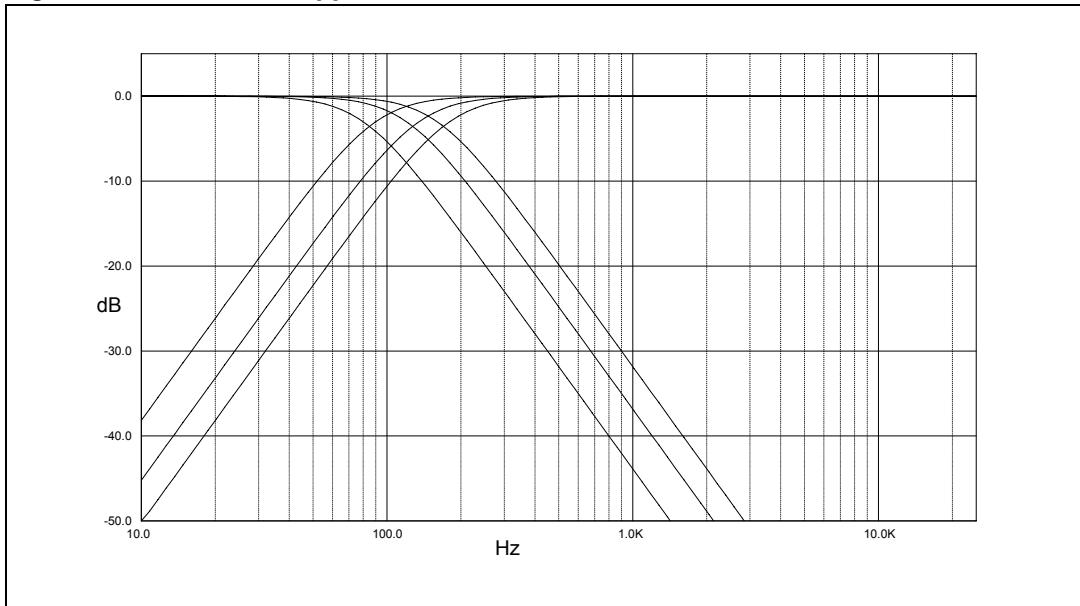

Both filters, the lowpass and the highpass-filter, have butterworth characteristics so that their cut off frequencies are not equal, but shifted by the factor 1.125 to get a flat frequency response.

4.9 Voice band application

Figure 16. Voiceband application with HPF 300/450/600/750Hz and LPF 3k/6kHz

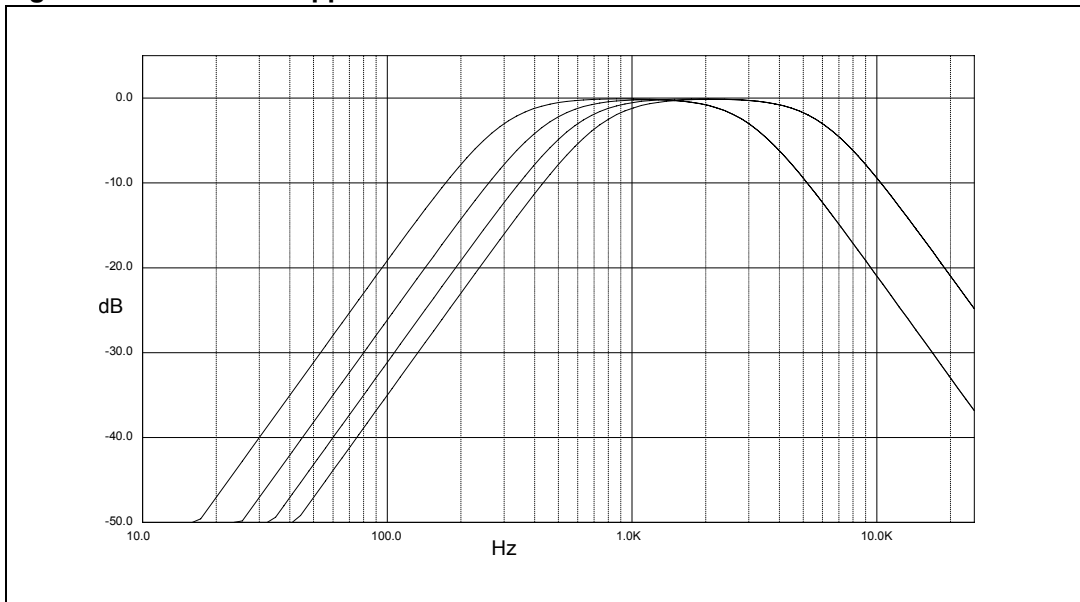

4.10 Componder

Signal compression

A fully integrated signal compressor with programmable attack and decay times is present in the A619 (see [Figure 17](#)).

The compander consists of a signal level detection, an A/D Converter plus adder and the normal softstep volume stage. First of all the left and the right InGain-signal is rectified, respectively, and the logarithm is build from the summed signal. The following low-pass smooth the output-signal of the logarithm amplifier and improves the low frequency suppression. The low pass output-voltage then is A/D converted an added to the current volume-word defined by the I²C bus. Assuming reference level or higher at the compander input, the output of the ADC is 0. At lower levels the voltage is increasing with 1Bit/dB. It is obvious that with this configuration and a 0.5dB-step volume stage the compression rate is fixed to 2:1 (1dB less at the input leads to 0.5dB less at the output).

The internal reference level of the compander is programmable in three steps from 0.5V_{RMS} to 2V_{RMS}. For a proper behavior of the compression circuit it is mandatory to have at a 0dB input signal exactly the programmed reference level after the InGain-stage. E.g. at a configured reference-level of 0.5V_{RMS} the output of the InGain stage has to have also 0.5V_{RMS} at 0dB source-signal (Usually the 0dB for CD is defined as the maximum possible signal-level). To adapt the external level to the internal reference level the programmable attenuation in the differential stages and the InGain can be used.

Figure 17. Componder block diagram

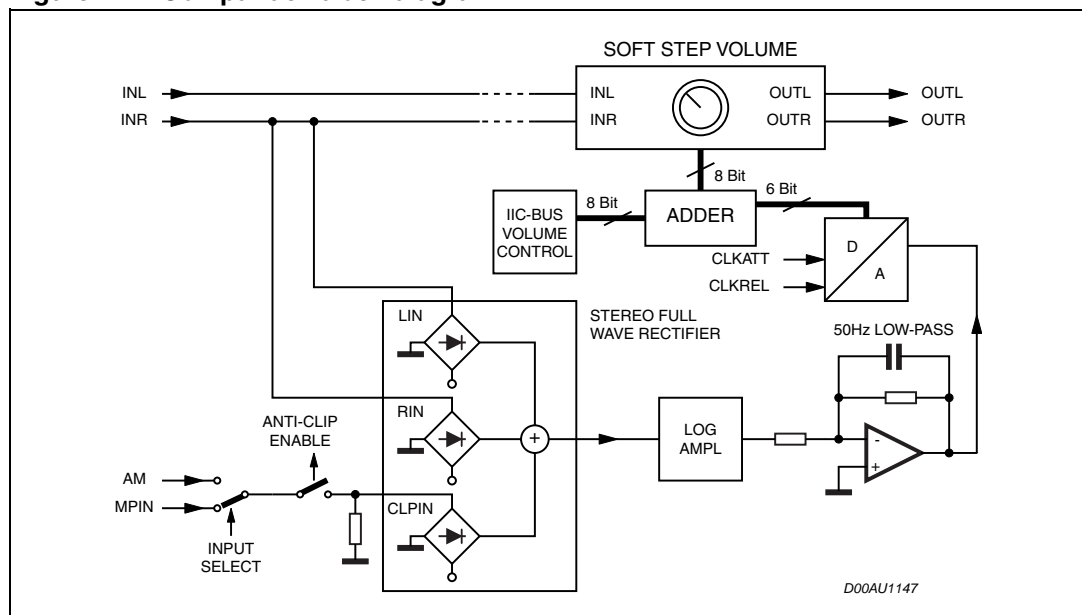

4.10.1 Anti-clipping

In a second application the compander-circuit can be used for a anti-clipping or limiting function. In this case one of the dedicated inputs (AM or MPin) is connected directly to the clip-detector of the power-amplifier. If no clipping is detected, the open-collector output of the power-amplifier is highohmic and the input-voltage of the rectifier is V_{REF}. The level detector interprets this as a very small signal and reacts with the maximum programmed compander gain. In the application this gain has to be compensated by decreasing the

volume with the same value in order to get the desired output-level. In clipping situation the open collector current generates a voltage drop at the rectifier input, which forces the compander to decrease the gain until the clipping disappears.

It is even possible to run the compression mode and the anti-clipping mode in parallel. In this case the maximum compander gain should be set to 29dB.

4.10.2 Characteristic

To achieve the desired compression characteristic like shown below the volume has to be decreased by 4dB.

Figure 18. Compander characteristic

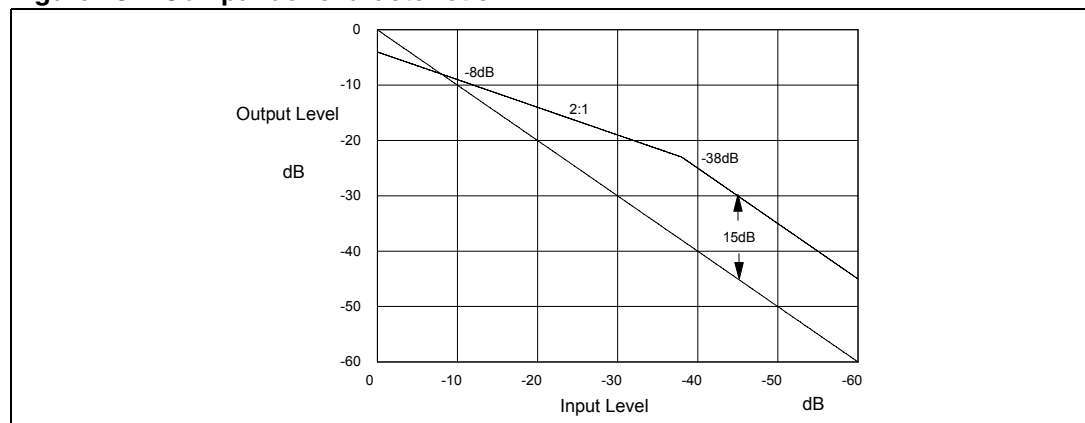

4.10.3 I²C bus timing

While the compander is working, a volume word coming from this stage is added to the I²C bus volume word, and the volume is changed with a soft slope between adjacent steps (softstep stage). As mentioned in the description of this stage, it is not recommended to change the volume during this slope. To avoid this while the compander is working and the volume has to be changed, the compander hold-bit is implemented (Bit 7 in the subaddress byte). The recommended timing for changing the volume during compander ON is the following:

1. Set the compander hold bit
2. Wait the actual softstep time
3. Change the volume
4. Reset the compander hold bit

The softstep-times are in compander ON condition automatically adapted to the attack time of the compander. In the following table the related SoftStep-times are shown:

Table 6. Attack times vs soft-step times

| Attack time | SoftStep time |
|-------------|---------------|
| 6ms | 0.16ms |
| 12ms | 0.32ms |
| 24ms | 0.64ms |
| 48ms | 1.28ms |

4.11 AC coupling

In some applications additional signal manipulations are desired, for example surround sound or more band equalizing. For this purpose an AC coupling is placed before the speaker attenuators, which can be activated or internally shorted by the I²C bus. In short condition the input signal of the speaker attenuator is available at the AC outputs. The input impedance of this AC Inputs is 50kΩ.

4.12 Output selector

The output-selector allows to connect the main- or the second-source to the front, rear and subwoofer speaker attenuator, respectively. As an example of this programming the device is able to connect via software the main source to the back (rear) and the second source to the front (see Figure 17). In addition to this stage allows to setup different applications by I²C bus programming. Three examples are given in Figure 18, 19, and 20.

Figure 19. Output selector

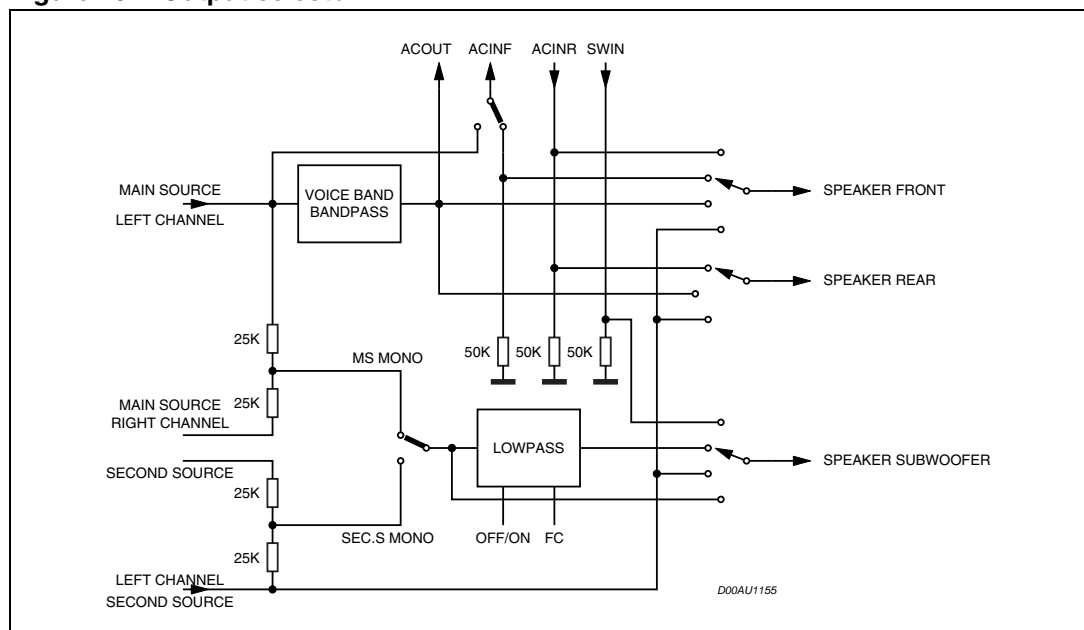

Figure 21. Application 2 using internal highpass and external stereo low pass filter

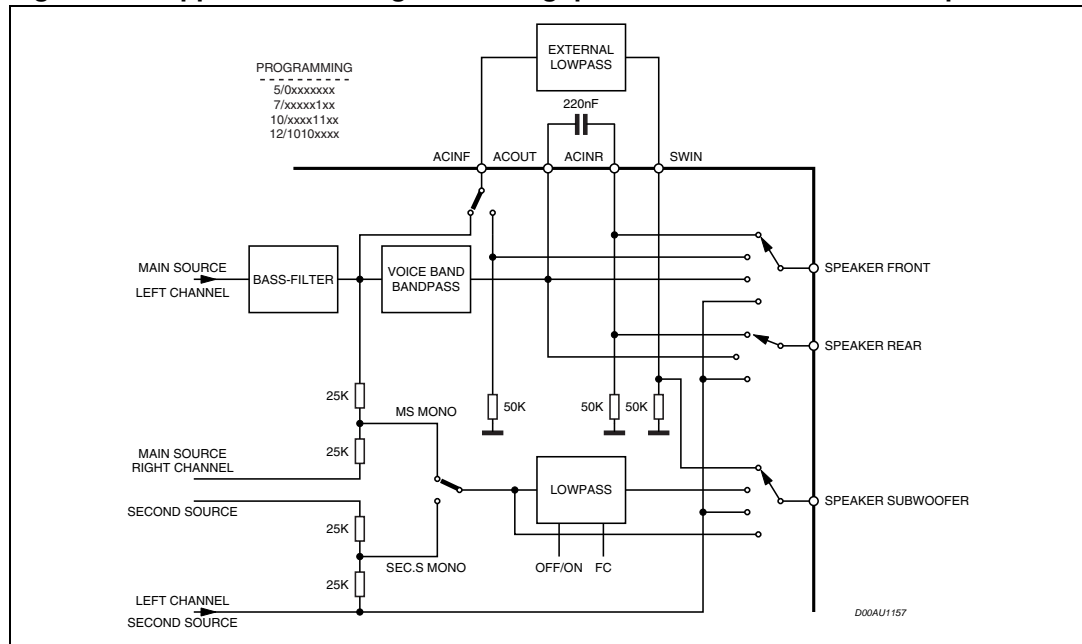
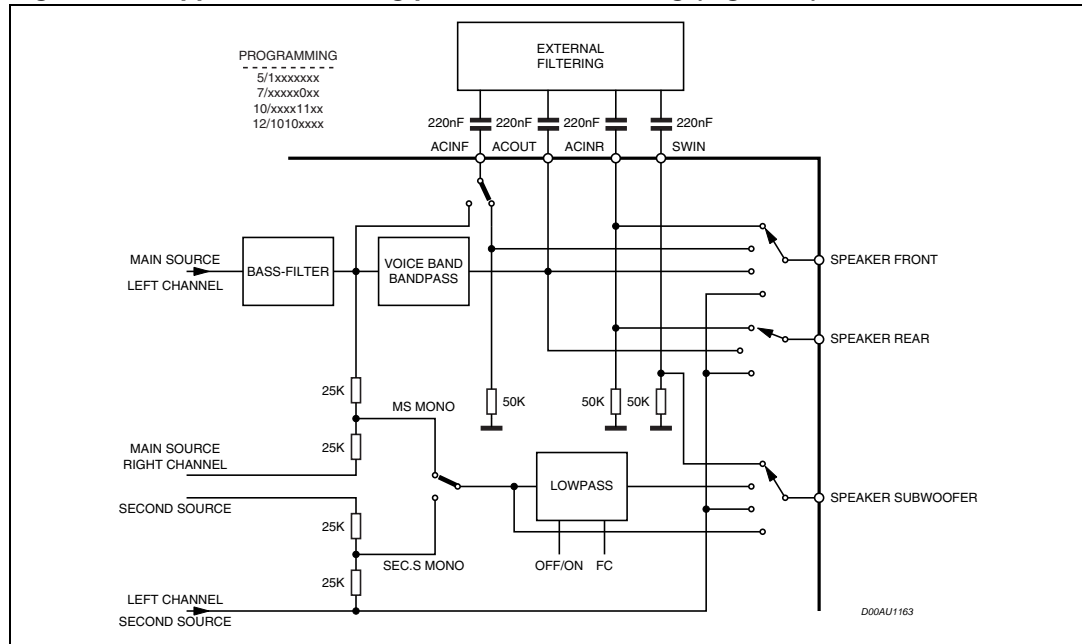

Figure 22. Application 3 using pure external filtering (e.g. DSP)



4.14 Speaker attenuator and mixing

A mixing-stage is placed after each speaker attenuator and can be set independently to mixing mode. Having a full volume for the mix signal the stage offers a wide flexibility to adapt the mixing levels.

Figure 23. Output selector

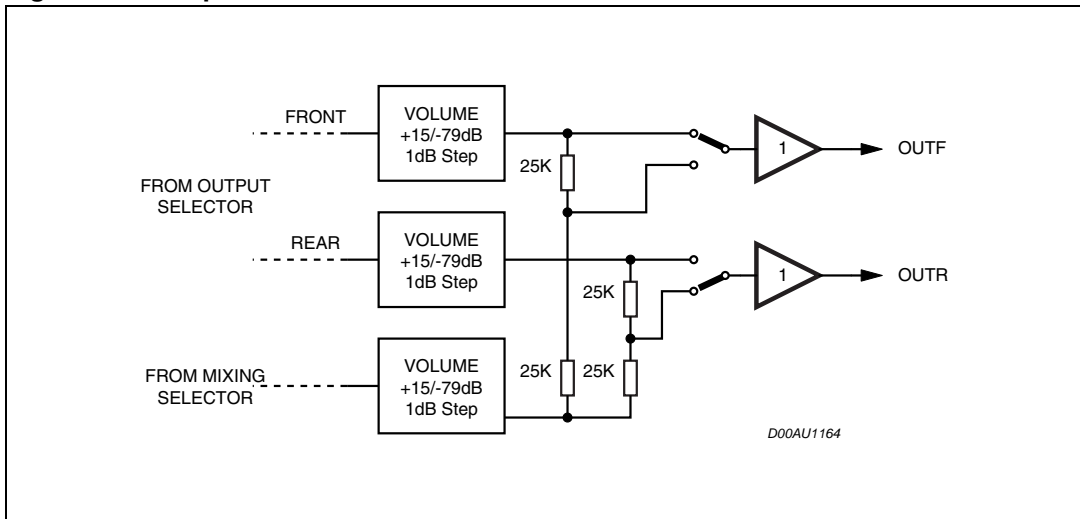

4.15 Audioprocessor testing

During the testmode, which can be activated by setting bit D_0 of the stereo decoder testing byte **and** the audioprocessor testing byte, several internal signals are available at the FD2R pin. During this mode the input resistance of 100kOhm is disconnected from the pin. The internal signals available are shown in the data byte specification.

5 Stereo decoder part

5.1 Features:

- No external components necessary
- PLL with adjustment free, fully integrated VCO
- Automatic pilot dependent MONO/STEREO switching
- Very high suppression of intermodulation and interference
- Programmable roll off compensation
- Dedicated RDS-softmute
- Highcut and stereo blend-characteristics programmable in a wide range
- FM/AM noiseblanker with several threshold controls
- Multipath-detector with programmable internal/external influence
- I²C-bus control of all necessary functions

5.2 Electrical characteristics

$V_S = 9V$, de-emphasis time constant = $50\mu s$, MPX input voltage $V_{MPX} = 500mV$ (75kHz deviation), modulation frequency = 1kHz, input gain = 6dB, $T_{amb} = 27^\circ C$, unless otherwise specified.

Table 7. Electrical characteristics

| Symbol | Parameter | Test condition | Min. | Typ. | Max. | Unit |
|---------------------------|----------------------------------|--------------------------------|------|------|------|-----------|
| V_{in} | MPX input level | Input gain = 3.5dB | | 0.5 | 1.25 | V_{rms} |
| R_{in} | Input resistance | | 70 | 100 | 130 | $k\Omega$ |
| G_{min} | Min. input gain | | 1.5 | 3.5 | 4.5 | dB |
| G_{max} | Max. input gain | | 8.5 | 11 | 12.5 | dB |
| G_{step} | Step resolution | | 1.75 | 2.5 | 3.25 | dB |
| SVRR | Supply voltage ripple rejection | $V_{ripple} = 100mV, f = 1kHz$ | | 55 | | dB |
| a | Max. channel separation | | 30 | 50 | | dB |
| THD | Total harmonic distortion | $f_{in}=1kHz, mono$ | | 0.02 | 0.3 | % |
| $\frac{S+N}{N}$ | Signal plus noise to noise ratio | A-weighted, $S = 2V_{rms}$ | 80 | 91 | | dB |
| Mono/Stereo-switch | | | | | | |
| V_{PTHST1} | Pilot threshold voltage | for stereo, PTH = 1 | 10 | 15 | 25 | mV |
| V_{PTHST0} | Pilot threshold voltage | for stereo, PTH = 0 | 15 | 25 | 35 | mV |
| V_{PTHMO1} | Pilot threshold voltage | for mono, PTH = 1 | 7 | 12 | 17 | mV |
| V_{PTHMO0} | Pilot threshold voltage | for mono, PTH = 0 | 10 | 19 | 25 | mV |
| PLL | | | | | | |
| $\Delta f/f$ | Capture range | | 0.5 | | | % |

Table 7. Electrical characteristics (continued)

| Symbol | Parameter | Test condition | Min. | Typ. | Max. | Unit |
|---|------------------------------------|-------------------------|------|------|------|---------|
| De-emphasis and highcut | | | | | | |
| $\tau_{DeempFM}$ | De-emphasis timeconstants FM | $V_{LEVEL} \gg V_{HCH}$ | 25 | 50 | 75 | μs |
| | | $V_{LEVEL} \gg V_{HCH}$ | 44 | 62.5 | 80 | μs |
| | | $V_{LEVEL} \gg V_{HCH}$ | 50 | 75 | 100 | μs |
| | | $V_{LEVEL} \gg V_{HCH}$ | 70 | 100 | 130 | μs |
| M_{FM} | Highcut timeconstant multiplier FM | $V_{LEVEL} \ll V_{HCL}$ | | 3 | | |
| $\tau_{DeempAM}$ | De-emphasis timeconstants AM | $V_{LEVEL} \gg V_{HCH}$ | | 37.5 | | μs |
| | | $V_{LEVEL} \gg V_{HCH}$ | | 47 | | μs |
| | | $V_{LEVEL} \gg V_{HCH}$ | | 56 | | μs |
| | | $V_{LEVEL} \gg V_{HCH}$ | | 75 | | μs |
| M_{AM} | Highcut timeconstant multiplier AM | $V_{LEVEL} \ll V_{HCL}$ | | 3.7 | | |
| REF5V | Internal reference voltage | | 4.7 | 5 | 5.3 | V |
| L_{min} | min. LEVEL gain | | -1 | 0 | 1 | dB |
| L_{maxs} | max. LEVEL gain | | 5 | 6 | 7 | dB |
| L_{Gstep} | LEVEL gain step resolution | see section 2.7 | 0.2 | 0.4 | 0.6 | dB |
| $VSBL_{min}$ | Min. voltage for mono | see section 2.8 | 17 | 20 | 23 | %REF 5V |
| $VSBL_{max}$ | Max. voltage for mono | see section 2.8 | 62 | 70 | 78 | %REF 5V |
| $VSBL_{step}$ | Step resolution | see section 2.8 | 1.6 | 3.3 | 5.0 | %REF 5V |
| $VHCH_{min}$ | Min. voltage for NO highcut | see section 2.9 | 37 | 42 | 47 | %REF 5V |
| $VHCH_{max}$ | Max. voltage for NO highcut | see section 2.9 | 58 | 66 | 74 | %REF 5V |
| $VHCH_{step}$ | Step resolution | see section 2.9 | 4.2 | 8.4 | 12.6 | %REF 5V |
| $VHCL_{min}$ | Min. voltage for FULL high cut | see section 2.9 | 15 | 17 | 19 | %VHCH |
| $VHCL_{max}$ | Max. voltage for FULL high cut | see section 2.9 | 29 | 33 | 37 | %VHCH |
| $VHCL_{step}$ | Step resolution | see section 2.9 | 2.1 | 4.2 | 6.3 | %REF 5V |
| Carrier and harmonic suppression at the output | | | | | | |
| α_{19} | Pilot signal f=19kHz | | 40 | 50 | | dB |
| α_{38} | Subcarrier f=38kHz | | | 75 | | dB |
| α_{57} | Subcarrier f=57kHz | | | 62 | | dB |
| α_{76} | Subcarrier f=76kHz | | | 90 | | dB |

Table 7. Electrical characteristics (continued)

| Symbol | Parameter | Test condition | Min. | Typ. | Max. | Unit |
|---|------------------------------------|-------------------------|------|------|------|---------|
| De-emphasis and highcut | | | | | | |
| $\tau_{DeempFM}$ | De-emphasis timeconstants FM | $V_{LEVEL} \gg V_{HCH}$ | 25 | 50 | 75 | μs |
| | | $V_{LEVEL} \gg V_{HCH}$ | 44 | 62.5 | 80 | μs |
| | | $V_{LEVEL} \gg V_{HCH}$ | 50 | 75 | 100 | μs |
| | | $V_{LEVEL} \gg V_{HCH}$ | 70 | 100 | 130 | μs |
| M_{FM} | Highcut timeconstant multiplier FM | $V_{LEVEL} \ll V_{HCL}$ | | 3 | | |
| $\tau_{DeempAM}$ | De-emphasis timeconstants AM | $V_{LEVEL} \gg V_{HCH}$ | | 37.5 | | μs |
| | | $V_{LEVEL} \gg V_{HCH}$ | | 47 | | μs |
| | | $V_{LEVEL} \gg V_{HCH}$ | | 56 | | μs |
| | | $V_{LEVEL} \gg V_{HCH}$ | | 75 | | μs |
| M_{AM} | Highcut timeconstant multiplier AM | $V_{LEVEL} \ll V_{HCL}$ | | 3.7 | | |
| REF5V | Internal reference voltage | | 4.7 | 5 | 5.3 | V |
| L_{min} | min. LEVEL gain | | -1 | 0 | 1 | dB |
| L_{maxs} | max. LEVEL gain | | 5 | 6 | 7 | dB |
| L_{Gstep} | LEVEL gain step resolution | see section 2.7 | 0.2 | 0.4 | 0.6 | dB |
| $VSBL_{min}$ | Min. voltage for mono | see section 2.8 | 17 | 20 | 23 | %REF 5V |
| $VSBL_{max}$ | Max. voltage for mono | see section 2.8 | 62 | 70 | 78 | %REF 5V |
| $VSBL_{step}$ | Step resolution | see section 2.8 | 1.6 | 3.3 | 5.0 | %REF 5V |
| $VHCH_{min}$ | Min. voltage for NO highcut | see section 2.9 | 37 | 42 | 47 | %REF 5V |
| $VHCH_{max}$ | Max. voltage for NO highcut | see section 2.9 | 58 | 66 | 74 | %REF 5V |
| $VHCH_{step}$ | Step resolution | see section 2.9 | 4.2 | 8.4 | 12.6 | %REF 5V |
| $VHCL_{min}$ | Min. voltage for FULL high cut | see section 2.9 | 15 | 17 | 19 | %VHCH |
| $VHCL_{max}$ | Max. voltage for FULL high cut | see section 2.9 | 29 | 33 | 37 | %VHCH |
| $VHCL_{step}$ | Step resolution | see section 2.9 | 2.1 | 4.2 | 6.3 | %REF 5V |
| Carrier and harmonic suppression at the output | | | | | | |
| α_{19} | Pilot signal f=19kHz | | 40 | 50 | | dB |
| α_{38} | Subcarrier f=38kHz | | | 75 | | dB |
| α_{57} | Subcarrier f=57kHz | | | 62 | | dB |
| α_{76} | Subcarrier f=76kHz | | | 90 | | dB |

Table 7. Electrical characteristics (continued)

| Symbol | Parameter | Test condition | Min. | Typ. | Max. | Unit |
|---|--|----------------|------|------|------|------|
| Intermodulation (Note 2.3.1) | | | | | | |
| α_2 | $f_{\text{mod}}=10\text{kHz}, f_{\text{spur}}=1\text{kHz}$ | | | 65 | | dB |
| α_3 | $f_{\text{mod}}=13\text{kHz}, f_{\text{spur}}=1\text{kHz}$ | | | 75 | | dB |
| Traffic Radio (Note 2.3.2) | | | | | | |
| α_{57} | Signal $f=57\text{kHz}$ | | | 70 | | dB |
| SCA - Subsidiary Communications Authorization (Note 2.3.3) | | | | | | |
| α_{67} | Signal $f = 67\text{kHz}$ | | | 75 | | dB |
| ACI - Adjacent Channel Interference (Note 2.3.4) | | | | | | |
| α_{114} | Signal $f=114\text{kHz}$ | | | 95 | | dB |
| α_{190} | Signal $f=190\text{kHz}$ | | | 84 | | dB |

5.3 Notes about the characteristics

5.3.1 Intermodulation suppression

$$\alpha_2 = \frac{V_O(\text{signal})(\text{at}1\text{kHz})}{V_O(\text{spurious})(\text{at}1\text{kHz})}; f_s = (2 \cdot 10\text{kHz}) - 19\text{kHz}$$

$$\alpha_3 = \frac{V_O(\text{signal})(\text{at}1\text{kHz})}{V_O(\text{spurious})(\text{at}1\text{kHz})}; f_s = (3 \cdot 13\text{kHz}) - 38\text{kHz}$$

measured with: 91% pilot signal; $f_m = 10\text{kHz}$ or 13kHz .

5.3.2 Traffic radio (V.F.) suppression

$$\alpha_{57}(\text{V.W.F.}) = \frac{V_O(\text{signal})(\text{at}1\text{kHz})}{V_O(\text{spurious})(\text{at}1\text{kHz} \pm 23\text{kHz})}$$

measured with: 91% stereo signal; 9% pilot signal; $f_m=1\text{kHz}$; 5% subcarrier ($f=57\text{kHz}$, $f_m=23\text{Hz}$ AM, $m=60\%$)

5.3.3 SCA (subsidiary communications authorization)

$$\alpha_{67} = \frac{V_O(\text{signal})(\text{at}1\text{kHz})}{V_O(\text{spurious})(\text{at}1\text{kHz})}; f_s = (2 \cdot 38\text{kHz}) - 67\text{kHz}$$

measured with: 81% mono signal; 9% pilot signal; $f_m=1\text{kHz}$; 10%SCA - subcarrier ($f_s = 67\text{kHz}$, unmodulated).

5.3.4 ACI (adjacent channel interference)

$$\alpha_{114} = \frac{V_{O(\text{signal})}(\text{at } 1\text{kHz})}{V_{O(\text{spurious})}(\text{at } 4\text{kHz})}; f_s = 110\text{kHz} - (3 \cdot 38\text{kHz})$$

$$\alpha_{190} = \frac{V_{O(\text{signal})}(\text{at } 1\text{kHz})}{V_{O(\text{spurious})}(\text{at } 4\text{kHz})}; f_s = 186\text{kHz} - (5 \cdot 38\text{kHz})$$

measured with: 90% mono signal; 9% pilot signal; fm=1kHz; 1% spurious signal (f_s = 110kHz or 186kHz, unmodulated).

5.4 Noise blanker part

5.4.1 Features:

- AM and FM mode
- internal 2nd order 140kHz high-pass filter for MPX path
- internal rectifier and filters for AM-IF path
- programmable trigger thresholds
- trigger threshold dependent on high frequency noise with programmable gain
- additional circuits for deviation and fieldstrength dependent trigger adjustment
- 4 selectable pulse suppression times for each mode
- programmable noise rectifier charge/discharge current

All parameters measured in FM mode if not otherwise specified.

Table 8. Electrical characteristics

| Symbol | Parameter | Test condition | Min. | Typ. | Max. | Unit |
|----------------------|---------------------------------------|--------------------------------------|------|------|------|------------------|
| V _{TR} | Trigger threshold ⁽¹⁾ | meas.with V _{PEAK} =0.9V | 111 | 30 | | mV _{OP} |
| | | | 110 | 35 | | mV _{OP} |
| | | | 101 | 40 | | mV _{OP} |
| | | | 100 | 45 | | mV _{OP} |
| | | | 011 | 50 | | mV _{OP} |
| | | | 010 | 55 | | mV _{OP} |
| | | | 001 | 60 | | mV _{OP} |
| | | | 000 | 65 | | mV _{OP} |
| V _{TRNOISE} | Noise controlled Trigger threshold | meas.with V _{PEAK} =1.5V | 00 | 260 | | mV _{OP} |
| | | | 01 | 220 | | mV _{OP} |
| | | | 10 | 180 | | mV _{OP} |
| | | | 11 | 140 | | mV _{OP} |

Table 8. Electrical characteristics

| Symbol | Parameter | Test condition | | Min. | Typ. | Max. | Unit |
|-------------------|--|--|----|------|----------|------|-------------|
| V_{RECT} | Rectifier voltage | $V_{MPX}=0mV$ | | 0.5 | 0.9 | 1.3 | V |
| | | $V_{MPX}=50mV, f=150kHz$ | | 1.5 | 1.7 | 2.1 | V |
| | | $V_{MPX}=200mV, f=150kHz$ | | 2 | 2.5 | 2.9 | V |
| V_{RECTDE} V | Deviation dependent rectifier voltage | meas.with $V_{MPX}=500mV$ (75kHz dev.) | 11 | 0.5 | 0.9(off) | 1.3 | V_{OP} |
| | | | 10 | 0.9 | 1.2 | 1.5 | V_{OP} |
| | | | 01 | 1.7 | 2.0 | 2.3 | V_{OP} |
| | | | 00 | 2.5 | 2.8 | 3.1 | V_{OP} |
| V_{RECTFS} | Fieldstrength controlled rectifier voltage | meas.with $V_{MPX}=0mV,$ $V_{LEVEL} \ll V_{SBL}$ (fully mono) | 11 | 0.5 | 0.9(off) | 1.3 | V |
| | | | 10 | 0.9 | 1.4 | 1.5 | V |
| | | | 01 | 1.7 | 1.9 | 2.3 | V |
| | | | 00 | 2.1 | 2.4 | 3.1 | V |
| T_{SFM} | Suppression pulse duration FM | Signal HOLDN in testmode | 00 | | 38 | | μs |
| | | | 01 | | 25.5 | | μs |
| | | | 10 | | 32 | | μs |
| | | | 11 | | 22 | | μs |
| T_{SAM} | Suppression pulse duration AM | Signal HOLDN in testmode | 00 | | 1.2 | | ms |
| | | | 01 | | 800 | | μs |
| | | | 10 | | 1.0 | | μs |
| | | | 11 | | 640 | | μs |
| V_{RECTAD} J | Noise rectifier discharge ⁽²⁾ adjustment | Signal PEAK in testmode | 00 | | 0.3 | | V/ms |
| | | | 01 | | 0.8 | | |
| | | | 10 | | 1.3 | | |
| | | | 11 | | 2.0 | | |
| SR_{PEAK} | Noise rectifier ⁽²⁾ charge | Signal PEAK in testmode | 0 | | 10 | | mV/ μs |
| | | | 1 | | 20 | | |
| V_{ADJMP} | Noise rectifier adjustment through multipath ⁽²⁾ | Signal PEAK in testmode | 00 | | 0.3 | | V/ms |
| | | | 01 | | 0.5 | | |
| | | | 10 | | 0.7 | | |
| | | | 11 | | 0.9 | | |
| R_{AMIF} | AM IF Input resistance | | | 35 | 50 | 65 | kOhm |
| $G_{AMIF,min}$ | min. gain AM IF | Signal AM-RECTIFIER in Testmode | | | 6 | | dB |
| $G_{AMIF,max}$ | max. gain AM IF | | | | 20 | | dB |
| $G_{AMIF,step}$ | step gain AM IF | | | | 2 | | dB |
| $f_{AMIF,min}$ | min. f_c AM IF | Signal AM-RECTIFIER in Testmode | | | 14 | | kHz |
| $f_{AMIF,max}$ | max. f_c AM IF | | | | 56 | | kHz |

1. All thresholds are measured using a pulse with $TR = 2 \mu s$, $THIGH = 2 \mu s$ and $TF = 10 \mu s$. The repetition rate must not increase the PEAK voltage.

2. By design/characterization functionally guaranteed through dedicated test mode structure

Figure 24. V_n timing diagram

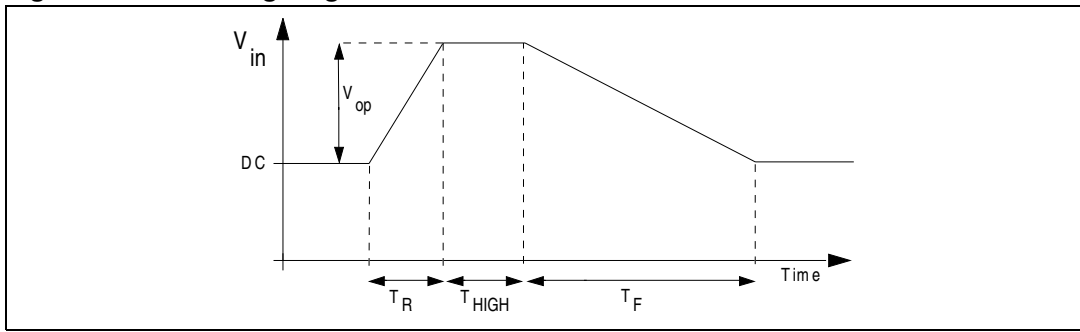

Figure 25. Trigger threshold vs. V_{PEAK}

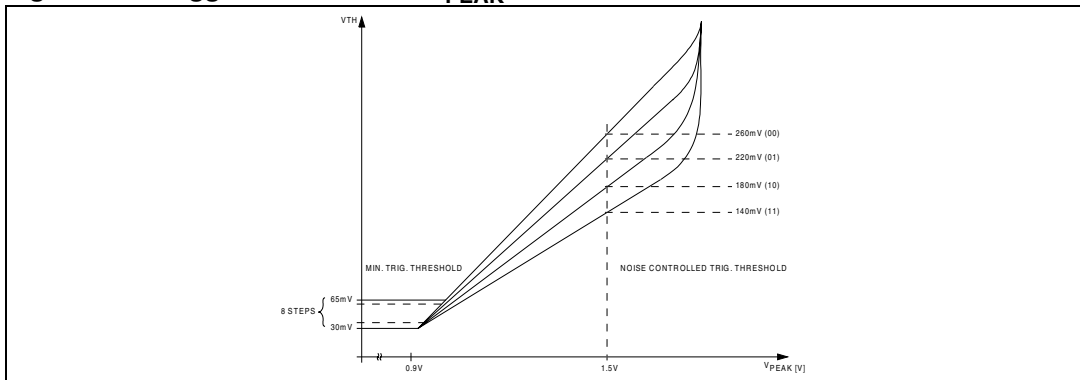

Figure 26. Deviation controlled trigger adjustment

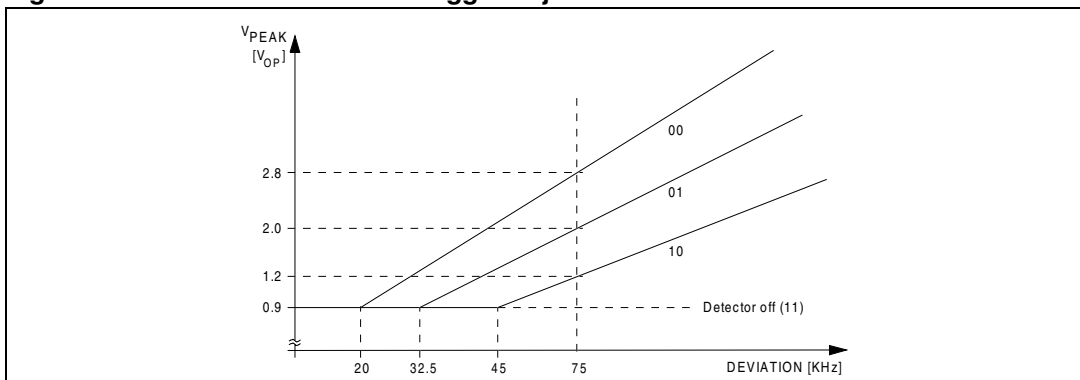
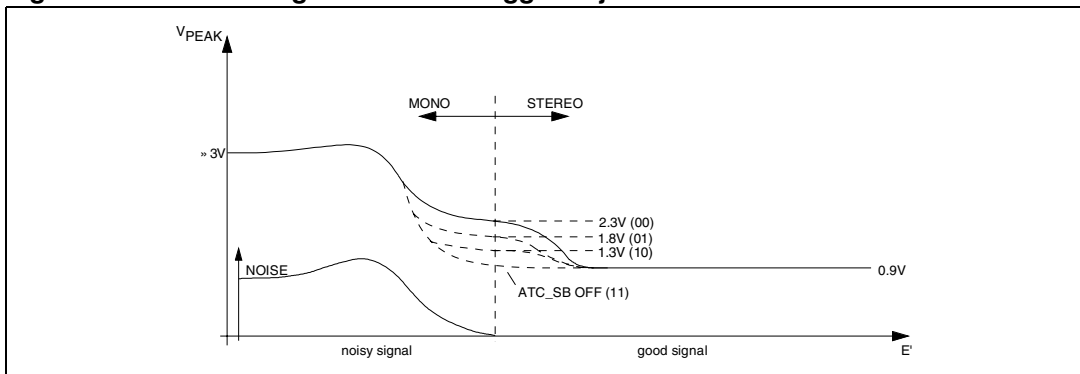

Figure 27. Field strength controlled trigger adjustment



5.5 Multipath detector

5.5.1 Features:

- internal 19kHz band pass filter
- programmable band pass and rectifier gain
- selectable internal influence on stereo blend and/or Highcut

Table 9. Electrical characteristics of multipath detector

| Symbol | Parameter | Test Condition | Min. | Typ. | Max. | Unit |
|-------------------------|--|-------------------------------------|------|-------------|------|---------------|
| f_{CMP} | Center frequency of multipath-bandpass | Stereo decoder locked on pilot tone | | 19 | | kHz |
| G_{BPMP} | Bandpass gain | G1 | | 6 | | dB |
| | | G2 | | 12 | | dB |
| | | G3 | | 16 | | dB |
| | | G4 | | 18 | | dB |
| $G_{\text{RECTM P}}$ | Rectifier gain | G1 | | 7.6 | | dB |
| | | G2 | | 4.6 | | dB |
| | | G3 | | 0 | | dB |
| I_{CHMP} | Rectifier charge current | | | 0.25 0.5 | | μA |
| I_{DISMP} | Rectifier discharge current | | | 4 | | mA |
| Quality detector | | | | | | |
| A | Multipath influence factor | 00 | | 0.70 | | |
| | | 01 | | 0.85 | | |
| | | 10 | | 1.00 | | |
| | | 11 | | 1.15 | | |

6 Functional description of stereo decoder

Figure 28. Block diagram of stereo decoder

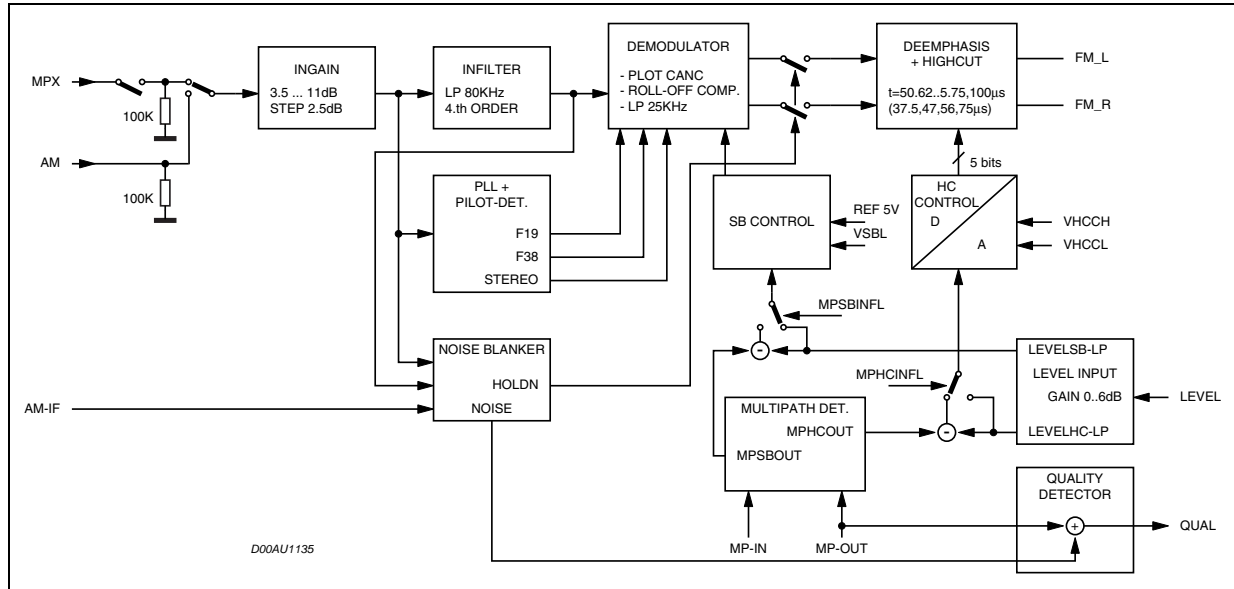

The stereo decoder-part of the A619 (see [Figure 28](#)) contains all functions necessary to demodulate the MPX-signal like pilot tone dependent Mono/Stereo switching as well as "stereo blend" and "highcut". Adaptations like programmable input gain, roll off compensation, selectable de-emphasis time constant and a programmable fieldstrength input allow to use different IF devices.

6.1 Stereo decoder mute

The A619 has a fast and easy to control RDS mute function which is a combination of the audioprocessor's SoftMute and the high ohmic mute of the stereo decoder. If the stereo decoder is selected and a SoftMute command is sent (or activated through the SM-pin) the stereo decoder will be set automatically to the high-ohmic mute condition after the audio-signal has been softmuted. Hence a checking of alternate frequencies could be performed. Additionally the PLL can be set to "Hold" mode, which disables the PLL input during the mute time. To release the system from the mute condition simply the unmute command must be sent: the stereo decoder is unmuted immediately and the audioprocessor is softly unmuted. Fig. 26 shows the output-signal V_O as well as the internal stereo decoder mute signal. This influence of SoftMute on the stereo decoder mute can be switched off by setting bit 3 of the SoftMute byte to "0". A stereo decoder mute command (bit 0, stereo decoder byte set to "1") will also set the stereo decoder independently to the high-ohmic mute state.

If any other source than the stereo decoder is selected the decoder remains muted and the MPX pin is connected to V_{ref} to avoid any discharge of the coupling capacitor through leakage currents. No further mute command should be applied.

Figure 29. Signals during stereo decoder's SoftMute

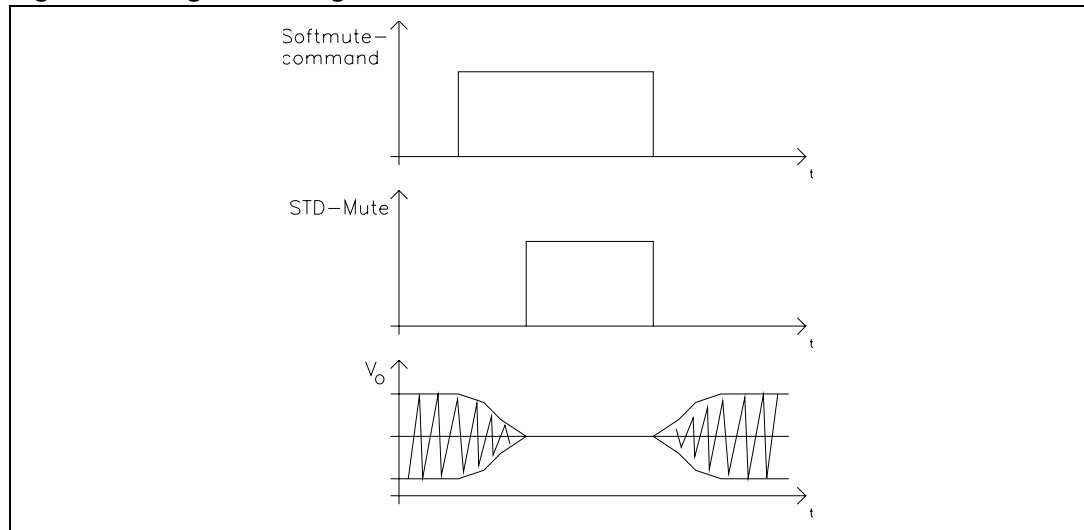
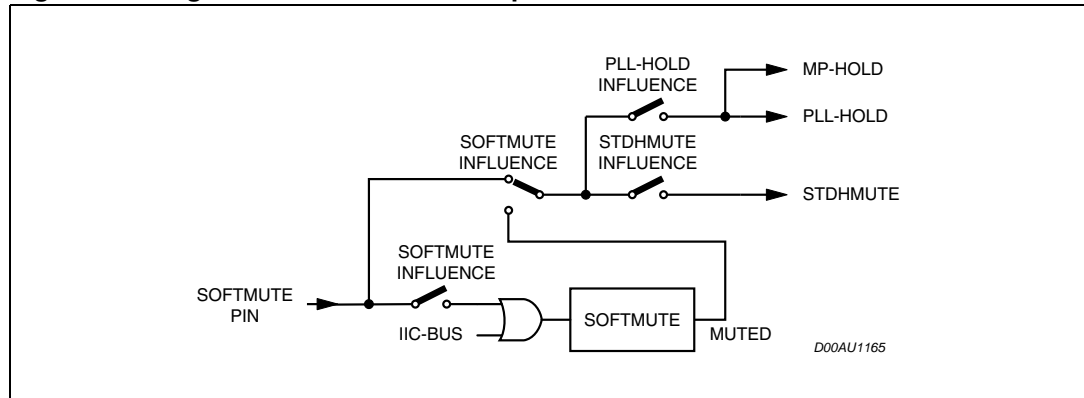

Figure 30. Signal control via SoftMute pin



6.2 InGain + infilter

The InGain stage allows adjustment of the MPX-signal to a magnitude of about $1V_{rms}$ internally, which is the recommended value. The 4th order input filter has a corner frequency of 80kHz and is used to attenuate spikes and noise, and acts as an anti-aliasing filter for the following switch capacitor filters.

6.3 Demodulator

In the demodulator block, the left and the right channels are separated from the MPX signal. In this stage the 19kHz pilot tone is cancelled. To reach a high channel separation the A619 offers an I²C bus programmable roll-off adjustment which is able to compensate for the lowpass behavior of the tuner section. If the tuner's attenuation at 38kHz is in a range from 7.2% to 31.0%, the A619 needs no external network in front of the MPX-pin. Within this range, an adjustment to obtain at least 40dB channel separation is possible. The bits for this adjustment are located together with the fieldstrength adjustment in one byte. This gives the possibility to perform an optimization step during the production of the car radio, where the

channel separation and the fieldstrength control are trimmed. The setup of the stereo blend characteristics which is programmable in a wide range is described in [Chapter 6.8](#).

6.4 De-emphasis and highcut

The de-emphasis lowpass allows to choose a time constant between 37.5 and 100 μ s. The highcut control range will be $2 \times \tau_{Deemp}$ or $2.7 \times \tau_{Deemp}$ dependent on the selected time constant (see programming section). The bit D7 of the highcut-byte will shift timeconstant and range.

Inside the highcut control range (between VHCH and VHCL) the LEVEL signal is converted into a 5 bit word which controls the lowpass time constant between $\tau_{Deemp} \dots 3 (3.7) \times \tau_{Deemp}$. Thereby the resolution will remain always 5 bits independently of the absolute voltage range between the VHCH and VHCL values. In addition the maximum attenuation can be fixed between 2 and 10dB.

The highcut function can be switched off by I²C bus (bit D₇, Highcut byte set to "0").

The setup of the highcut characteristics is described in [Chapter 6.9](#).

6.5 PLL and pilot tone detector

The PLL has the task to lock on the 19kHz pilot tone during a stereo transmission to allow a correct demodulation. The included pilot tone-detector enables the demodulation if the pilot tone reaches the selected pilot tone threshold V_{PTHST} . Two different thresholds are available. The detector output (signal STEREO, see the Block diagram) can be checked by reading the status byte of the A619 via I²C-bus. During a Softmute the PLL can be set into "Hold"-mode which freezes the PLL's state (bit D₄, Softmute byte). After releasing the Softmute the PLL will again follow the input signal only by correcting the phase error.

6.6 Field strength control

The fieldstrength input is used to control the highcut and the stereo blend function. In addition the signal can be also used to control the noiseblanker thresholds and as input for the multipath detector. These additional functions are described in sections [6.3](#) and [7](#).

6.7 EVEL input and gain

To suppress undesired high frequency modulation on the highcut- and stereo blend-control signal the LEVEL signal is lowpass filtered firstly. The filter is a combination of a 1st order RC lowpass at 53kHz (working as anti-aliasing filter) and a 1st-order switched capacitor lowpass at 2.2kHz. The second stage is a programmable gain stage to adapt the LEVEL signal internally to different IF devices (see Testmode section 5: LEVELHCC). The gain is widely programmable in 16 steps from 0dB to 6dB (step=0.4dB). These 4 bits are located together with the Roll-Off bits in the "Stereo decoder adjustment" byte to simplify a possible adjustment during the production of the car radio. This signal controls directly the Highcut stage whereas the signal is filtered again (fc=100Hz) before the stereo blend stage (see [Figure 35](#)).

6.8 Stereo blend control

The stereo blend control block converts the internal LEVEL voltage (LEVELSB) into an demodulator compatible analog signal which is used to control the channel separation between 0dB and the maximum separation. Internally this control has a fixed upper limit which is the internal reference voltage REF5V. The lower limit can be programmed between 20 and 70% of REF5V in 3.3% steps (see [Figure 31](#) and [32](#)).

To adjust the external LEVEL voltage to the internal range two values must be defined: the LEVEL gain L_G and VSBL (see [Figure 32](#)). At the point of full channel separation the external level signal has to be amplified that internally it becomes equal to REF5V. The second point (e.g. 10dB channel sep.) is then adjusted with the VSBL voltage.

Figure 31. Internal stereo blend characteristics

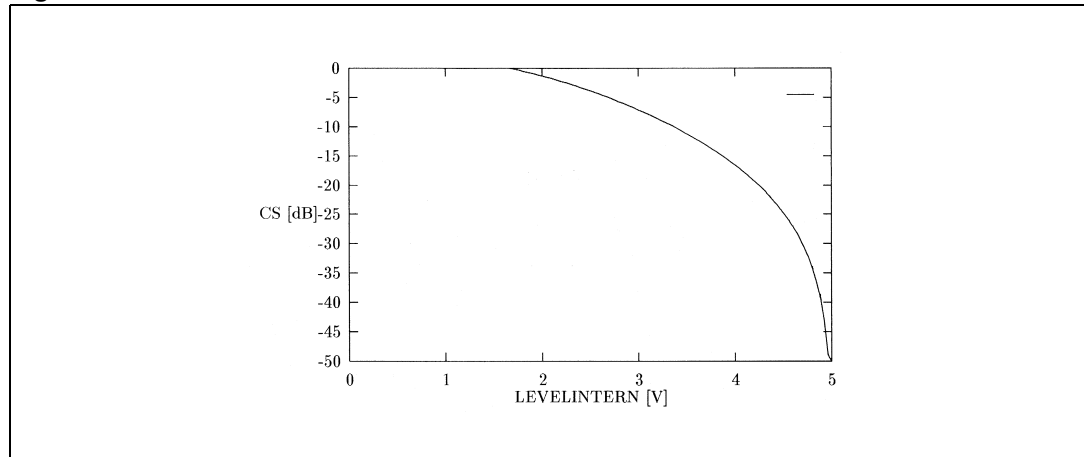

The gain can be programmed through 4 bits in the "Stereo decoder adjustment" byte. All necessary internal reference voltages like REF5V are derived from a bandgap circuit. Therefore they have a temperature co-efficient near zero.

Figure 32. Relation between internal and external LEVEL voltages for setup of stereo blend

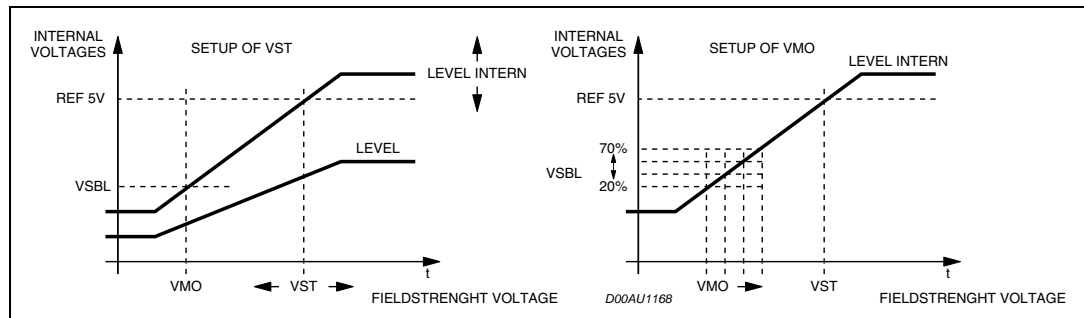

6.9 Highcut control

The highcut control set-up is similar to the stereo blend control set up : the starting point VHCH can be set with 2 bits to be 42, 50, 58 or 66% of REF5V whereas the range can be set to be 17, 22, 28 or 33% of VHCH (see [Figure 33](#)).

Figure 33. Highcut characteristics

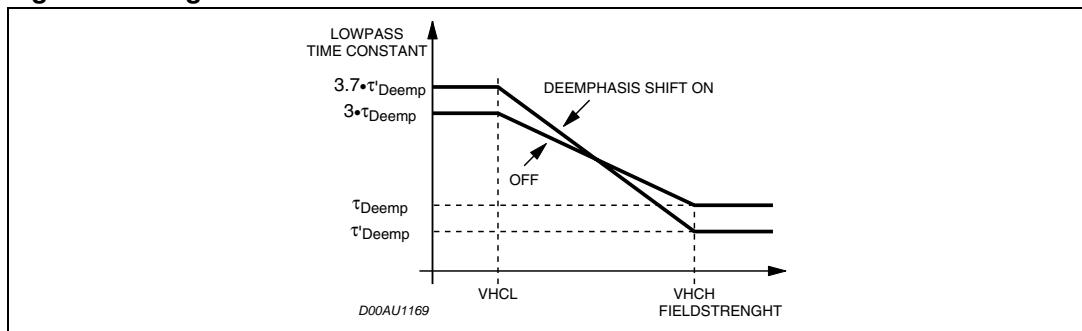

7 Functional description of the noise blanker

In the automotive environment the MPX-signal as well as the AM signal is disturbed by spikes produced by the ignition and other radiating sources like the wiper motor. The aim of the noiseblanker part is to cancel the audible influence of the spikes. Therefore the output of the stereo decoder is held at the actual voltage for a time between 22 and 38 μ s in FM (370 and 645 μ s in AM mode). The block diagram of the noise blanker is given in [Figure 34](#).

Figure 34. Block diagram of the noise blanker

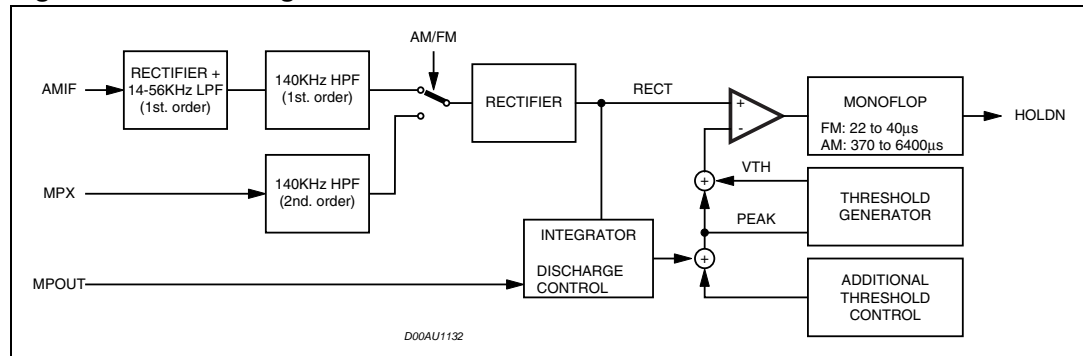

In a first stage the spikes must be detected but to avoid a wrong triggering on high frequency (white) noise a complex trigger control is implemented. Behind the trigger stage a pulse former generates the "blanking" pulse.

7.1 Trigger path FM

The incoming MPX signal is highpass-filtered, amplified and rectified. This second order highpass filter has a corner-frequency of 140kHz. The rectified signal, RECT, is integrated (lowpass filtered) to generate a signal called PEAK. The DC-charge/discharge behaviour can be adjusted as well as the transient behaviour (MP discharge control). Also noise with a frequency 140kHz increases the PEAK voltage. The PEAK voltage is fed to a threshold generator, which adds to the PEAK voltage a DC dependent threshold VTH. Both signals, RECT and PEAK+VTH are fed to a comparator which triggers a re-triggerable monoflop. The monoflop's output activates the sample and hold circuits in the signalpath for the selected duration.

7.2 Noise controlled threshold adjustment (NCT)

There are mainly two independent possibilities for programming the trigger threshold:

1. the low threshold in 8 steps (bits D_1 to D_3 of the noiseblanker byte I)
2. and the noise adjusted threshold in 4 steps (bits D_4 and D_5 of the noiseblanker byte I, see [Figure 21](#)).

The low threshold is active in combination with a good MPX signal without noise; the PEAK voltage is less than 1V. The sensitivity in this operation is high.

If the MPX signal is noisy (low fieldstrength) the PEAK voltage increases due to the higher noise, which is also rectified. With increasing of the PEAK voltage the trigger threshold increases, too. This gain is programmable in 4 steps (see [Figure 25](#)).

7.3 Additional threshold control mechanism

7.3.1 Automatic threshold control by the stereo blend voltage

Besides the noise controlled threshold adjustment there is an additional possibility for influencing the trigger threshold which depends on the stereo blend control.

The point where the MPX signal starts to become noisy is fixed by the RF part. Therefore also the starting point of the normal noise-controlled trigger adjustment is fixed ([Figure 27](#)). In some cases the behavior of the noiseblanker can be improved by increasing the threshold even in a region of higher fieldstrength. Sometimes a wrong triggering occurs for the MPX signal often shows distortion in this range which can be avoided even if using a low threshold. Because of the overlap of this range and the range of the stereo/mono transition it can be controlled by stereo blend. This increase of the threshold is programmable in 3 steps or switched off.

7.3.2 Over deviation detector

If the system is tuned to stations with a high deviation the noiseblanker can trigger on the higher frequencies of the modulation or distortion. To avoid this behavior, which causes audible noise in the output signal, the noiseblanker offers a deviation-dependent threshold adjustment. By rectifying the MPX signal a further signal representing the actual deviation is obtained. It is used to increase the PEAK voltage. Offset and gain of this circuit are programmable in 3 steps with the bits D_6 and D_7 of the noiseblanker byte I (bit combination '00' turns off the detector, see [Figure 26](#)).

7.3.3 Multipath level

To react on high repetitive spikes caused by a multipath-situation, the discharge time of the PEAK voltage can be decreased depending on the voltage-level at pin MPout. The A619 offers a linear as well as a threshold driven control. The linear influence of the multipath level on the PEAK-signal (D_7 of multipath control byte) gives a discharge slewrate of $1V/ms^{(1)}$. The second possibility is to activate the threshold driven discharge which switches on the 18kOhm discharge if the multipath level is below 2.5V (D_7 of noiseblanker byte II byte).

⁽¹⁾The slewrate is measured with $R_{Discharge}=\infty$ and $V_{MPout}=2.5V$

7.3.4 AM mode of the noiseblanker

The A619 noiseblanker is also suitable for AM noise cancelling. The detector uses in AM mode the 450kHz unfiltered IF output of the tuner for spike detection. A combination of programmable gain stage and lowpass filter forms an envelope detector which drives the noiseblanker's input via a 120kHz 1st order highpass. In order to blank the whole spike in AM mode the hold-times of the sample and hold circuit are much longer than in FM (640μs to 1.2ms). All threshold controls can be used like in FM mode.

8 Functional description of the multipath detector

Using the multipath detector the audible effects of a multipath condition can be minimized. A multipath condition is detected by rectifying the spectrum around 19kHz in the fieldstrength signal. An external capacitor is used to define the attack and decay times for the stereo blend (see block diagram, [Figure 34](#)). Due to the very small charge currents this capacitor should be a low leakage current type (e.g ceramic). Using this configuration an adaptation to the user's requirement is possible without effecting the "normal" fieldstrength input (level) for the stereo decoder. This application is given in [Figure 34](#). Another (internal) time constant is used to control the Highcut through the multipath detector

Selecting the "internal influence" in the configuration byte the stereo-blend and/or the highcut is automatically invoked during a multipath condition according to the voltage appearing at the MP_OUT pin.

Figure 35. Block diagram of the multipath detector

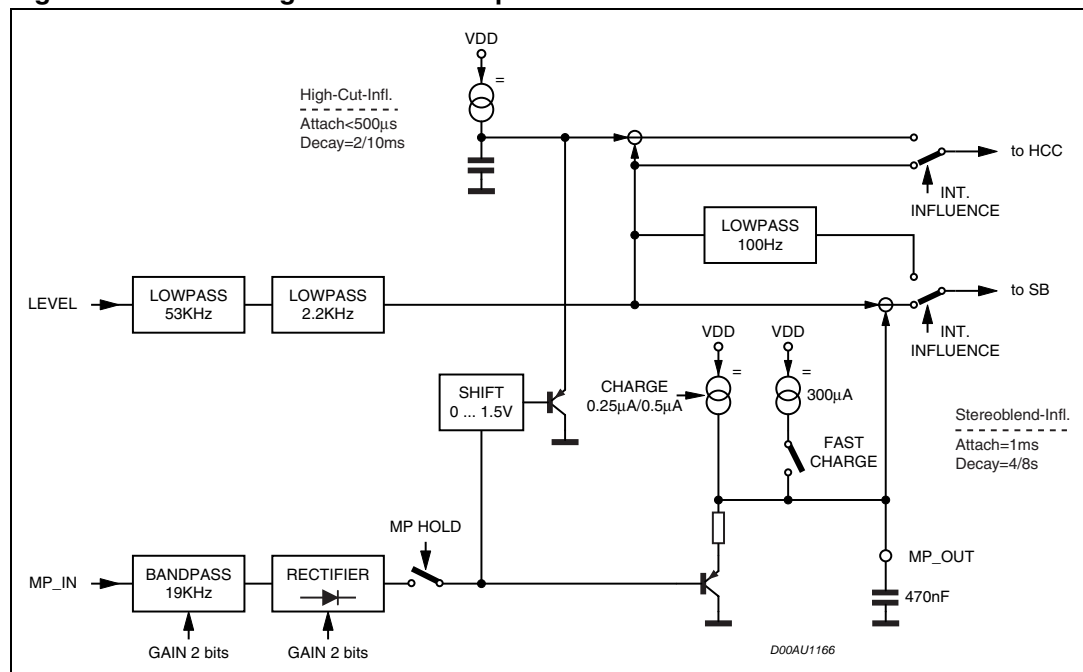

8.1 Quality detector

The A619 offers a quality detector output which gives a voltage representing the FM reception conditions. To calculate this voltage the MPX-noise and the multipath-detector output are summed according to the following formula :

$$V_{Qual} = 1.6 (V_{Noise} - 0.8 V) + a (REF5V - V_{Mput})$$

The noise-signal is the PEAK signal without additional influences (see the noiseblanker description). The factor 'a' can be programmed to 0.7 1.15. The output is a low impedance output able to drive external circuitry as well as simply fed to an AD converter for RDS applications.

8.2 Testmode

During the testmode, which can be activated by setting bit D_0 and bit D_1 of the stereo decoder testing byte, several internal signals are available at the FD2R+ pin. During this mode the input resistance of 100kOhm is disconnected from the pin. The internal signals available are shown in the Data byte specification.

8.3 Dual MPX usage

8.3.1 Feature description

The A619 is able to support a twin tuner concept via the Dual MPX Mode. In this configuration the MPX pin and the MD2G pin are acting as MPX1 and MPX2 inputs. The DC voltage at the MD2 pin controls whether one or both MPX signals are used to decode the stereo FM signal. It is designed as a window comparator with the characteristic shown in [Figure 3](#) (Please note that the thresholds have a hysteresis of 500mV).

In this mode the stereo decoder high ohmic-mute mutes both inputs in parallel.

Figure 36. Dual MPX input diagram

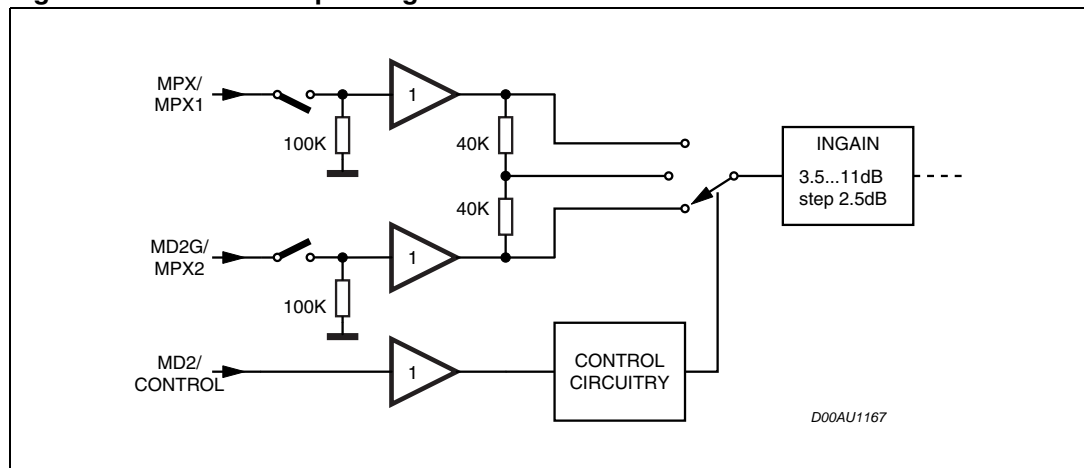

8.3.2 Configuration

The Dual MPX mode can be easily configured by setting bit 3 of subaddress 30 to LOW (see Byte 30 description and application diagram of [Figure 38](#)).

9.4 Subaddress (receive mode)

Table 12. Subaddress (receive mode)

| MSB | | | LSB | | | | | Function |
|----------------|----------------|----------------|----------------|----------------|----------------|----------------|----------------|---------------------------------|
| I ₂ | I ₁ | I ₀ | A ₄ | A ₃ | A ₂ | A ₁ | A ₀ | |
| 0 | | | | | | | | Compander hold |
| 1 | | | | | | | | off |
| | 0 | | | | | | | on |
| | 1 | | | | | | | AutoZero remain |
| | | | | | | | | off |
| | | | | | | | | on |
| | | 0 | | | | | | Auto Increment Mode |
| | | 1 | | | | | | off |
| | | | | | | | | on |
| | | | 0 | 0 | 0 | 0 | 0 | Subaddress |
| | | | 0 | 0 | 0 | 0 | 1 | Main Source Selector |
| | | | 0 | 0 | 0 | 1 | 0 | Main Loudness |
| | | | 0 | 0 | 0 | 1 | 1 | Volume |
| | | | 0 | 0 | 1 | 0 | 0 | Treble |
| | | | 0 | 0 | 1 | 0 | 1 | Bass |
| | | | 0 | 0 | 1 | 1 | 0 | Mixing Programming |
| | | | 0 | 0 | 1 | 1 | 1 | SoftMute |
| | | | 0 | 0 | 1 | 1 | 1 | Voice-Band |
| | | | 0 | 1 | 0 | 0 | 0 | Second Source Selector |
| | | | 0 | 1 | 0 | 0 | 1 | Second Source Loudness |
| | | | 0 | 1 | 0 | 1 | 0 | Subwoofer Config. / Bass |
| | | | 0 | 1 | 0 | 1 | 1 | Compander |
| | | | 0 | 1 | 1 | 0 | 0 | Configuration Audioprocessor I |
| | | | 0 | 1 | 1 | 0 | 1 | Configuration Audioprocessor II |
| | | | 0 | 1 | 1 | 1 | 0 | Subwoofer attenuator L |
| | | | 0 | 1 | 1 | 1 | 1 | Subwoofer attenuator R |
| | | | 1 | 0 | 0 | 0 | 0 | Speaker attenuator LF |
| | | | 1 | 0 | 0 | 0 | 1 | Speaker attenuator RF |
| | | | 1 | 0 | 0 | 1 | 0 | Speaker attenuator LR |
| | | | 1 | 0 | 0 | 1 | 1 | Speaker attenuator RR |
| | | | 1 | 0 | 1 | 0 | 0 | Mixing Level Control |
| | | | 1 | 0 | 1 | 0 | 1 | Testing Audioprocessor |
| | | | 1 | 0 | 1 | 1 | 0 | stereo decoder |
| | | | 1 | 0 | 1 | 1 | 1 | Noise-Blanker I |
| | | | 1 | 1 | 0 | 0 | 0 | Noise-Blanker II |
| | | | 1 | 1 | 0 | 0 | 1 | AM / AM-Noiseblanker |
| | | | 1 | 1 | 0 | 1 | 0 | High-Cut Control |
| | | | 1 | 1 | 0 | 1 | 1 | Fieldstr. & Quality |
| | | | 1 | 1 | 1 | 0 | 0 | Multipath-Detector |
| | | | 1 | 1 | 1 | 0 | 1 | stereo decoder Adjustment |
| | | | 1 | 1 | 1 | 1 | 0 | Configuration stereo decoder |
| | | | 1 | 1 | 1 | 1 | 1 | Testing Sterodecoder |

9.5 Data byte specification

The status after power on reset is marked bold face / underlined in the programming tables.

Table 13. Main selector (0)

| MSB | | | | | | | LSB | Function |
|----------------|----------------|----------------|----------------|----------------|----------------|----------------|----------------|------------------------------|
| D ₇ | D ₆ | D ₅ | D ₄ | D ₃ | D ₂ | D ₁ | D ₀ | |
| | | | | | 0 | 0 | 0 | Source selector FD1 / SE2 |
| | | | | | 0 | 0 | 1 | SE3 |
| | | | | | 0 | 1 | 0 | FD2 |
| | | | | | 0 | 1 | 1 | SE1 |
| | | | | | 1 | 0 | 0 | MD2 |
| | | | | | 1 | 0 | 1 | MD1 / SE4 |
| | | | | | 1 | 1 | 0 | stereo decoder |
| | | | | | 1 | 1 | 1 | AM |
| | 0 | 0 | 0 | 0 | | | | Input gain 0dB |
| | 0 | 0 | 0 | 1 | | | | 1dB |
| | : | : | : | : | | | | : |
| | 1 | 1 | 1 | 0 | | | | 14dB |
| | 1 | 1 | 1 | 1 | | | | 15dB |
| 0 | | | | | | | | Mute off |
| 1 | | | | | | | | on |

Table 14. Main loudness (1)

| MSB | | | | | | | LSB | Function |
|----------------|----------------|----------------|----------------|----------------|----------------|----------------|----------------|-------------------------------|
| D ₇ | D ₆ | D ₅ | D ₄ | D ₃ | D ₂ | D ₁ | D ₀ | |
| | | | 0 | 0 | 0 | 0 | 0 | Attenuation 0 dB |
| | | | 0 | 0 | 0 | 0 | 1 | -1 dB |
| | | | : | : | : | : | : | : |
| | | | 0 | 1 | 1 | 1 | 0 | -14 dB |
| | | | 0 | 1 | 1 | 1 | 1 | -15 dB |
| | | | : | : | : | : | : | : |
| | | | 1 | 0 | 0 | 1 | 1 | -19 dB |
| | | | : | : | : | : | : | not allowed |
| | 0 | 0 | | | | | | Center frequency 200Hz |
| | 0 | 1 | | | | | | 400Hz |
| | 1 | 0 | | | | | | 600Hz |
| | 1 | 1 | | | | | | 800Hz |
| 0 | | | | | | | | Loudness order First order |
| 1 | | | | | | | | Second order |

Table 15. Volume (2)

| MSB | | | | | | | LSB | | Attenuation |
|----------------|----------------|----------------|----------------|----------------|----------------|----------------|----------------|-------------------------------|-------------|
| D ₇ | D ₆ | D ₅ | D ₄ | D ₃ | D ₂ | D ₁ | D ₀ | | |
| 0 | 0 | 0 | 0 | 0 | 0 | 0 | 0 | Gain/attenuation (+32.0dB) | |
| 0 | 0 | 0 | 0 | 0 | 0 | 0 | 1 | (+31.5dB) | |
| : | : | : | : | : | : | : | : | : | |
| 0 | 0 | 0 | 1 | 1 | 0 | 0 | 0 | +20.0dB | |
| 0 | 0 | 0 | 1 | 1 | 0 | 0 | 1 | +19.5dB | |
| 0 | 0 | 0 | 1 | 1 | 0 | 1 | 0 | +19.0dB | |
| : | : | : | : | : | : | : | : | : | |
| 0 | 0 | 1 | 1 | 1 | 1 | 1 | 1 | +0.5dB | |
| 0 | 1 | 0 | 0 | 0 | 0 | 0 | 0 | 0.0dB | |
| 0 | 1 | 0 | 0 | 0 | 0 | 0 | 1 | -0.5dB | |
| : | : | : | : | : | : | : | : | : | |
| 1 | 1 | 0 | 1 | 1 | 1 | 1 | 0 | -79.0dB | |
| 1 | 1 | 0 | 1 | 1 | 1 | 1 | 1 | -79.5dB | |

Note: It is not recommended to use a gain more than 20dB for system performance reason. In general, the maximum gain should be limited by software to the maximum value, which is needed for the system.

Table 16. Treble filter (3)

| MSB | | | | | | | LSB | | Function |
|----------------|----------------|----------------|----------------|----------------|----------------|----------------|----------------|---------------------------------------|----------|
| D ₇ | D ₆ | D ₅ | D ₄ | D ₃ | D ₂ | D ₁ | D ₀ | | |
| | | | 0 | 0 | 0 | 0 | 0 | Treble steps -15dB | |
| | | | 0 | 0 | 0 | 0 | 1 | -14dB | |
| | | | : | : | : | : | : | : | |
| | | | 0 | 1 | 1 | 1 | 0 | -1 dB | |
| | | | 0 | 1 | 1 | 1 | 1 | 0 dB | |
| | | | 1 | 1 | 1 | 1 | 1 | 0 dB | |
| | | | 1 | 1 | 1 | 1 | 0 | +1 dB | |
| | | | : | : | : | : | : | : | |
| | | | 1 | 0 | 0 | 0 | 1 | +14 dB | |
| | | | 1 | 0 | 0 | 0 | 0 | +15dB | |
| | 0 | 0 | | | | | | Treble center frequency 10.0 kHz | |
| | 0 | 1 | | | | | | 12.5 kHz | |
| | 1 | 0 | | | | | | 15.0 kHz | |
| | 1 | 1 | | | | | | 17.5 kHz | |
| 0 | | | | | | | | Subwoofer + center speaker mode On | |
| 1 | | | | | | | | Off | |

Table 17. Bass filter (4)

| MSB | | | | | | | LSB | | Function |
|----------------|----------------|----------------|----------------|----------------|----------------|----------------|----------------|---------------|----------|
| D ₇ | D ₆ | D ₅ | D ₄ | D ₃ | D ₂ | D ₁ | D ₀ | | |
| | | | 0 | 0 | 0 | 0 | 0 | Bass steps | |
| | | | 0 | 0 | 0 | 0 | 1 | -15dB | |
| | | | : | : | : | : | : | -14dB | |
| | | | 0 | 1 | 1 | 1 | 0 | : | |
| | | | 0 | 1 | 1 | 1 | 1 | -1 dB | |
| | | | 1 | 1 | 1 | 1 | 1 | 0 dB | |
| | | | 1 | 1 | 1 | 1 | 0 | 0 dB | |
| | | | : | : | : | : | : | +1 dB | |
| | | | 1 | 0 | 0 | 0 | 1 | : | |
| | | | 1 | 0 | 0 | 0 | 0 | +14 dB | |
| | | | | | | | | +15dB | |
| | 0 | 0 | | | | | | Bass Q-factor | |
| | 0 | 1 | | | | | | 1.0 | |
| | 1 | 0 | | | | | | 1.25 | |
| | 1 | 1 | | | | | | 1.5 | |
| | | | | | | | | 2.0 | |
| 0 | | | | | | | | Bass DC-mode | |
| 1 | | | | | | | | Off | |
| | | | | | | | | On | |

Table 18. Mixing programming (5)

| MSB | | | | | | | LSB | | Function |
|----------------|----------------|----------------|----------------|----------------|----------------|----------------|----------------|---|----------|
| D ₇ | D ₆ | D ₅ | D ₄ | D ₃ | D ₂ | D ₁ | D ₀ | | |
| | | | | | | | 0 | Mixing | |
| | | | | | | | 1 | Mute enable | |
| | | | | | 0 | 0 | | Mixing source | |
| | | | | | 0 | 1 | | Beep | |
| | | | | | 1 | 0 | | MD1 | |
| | | | | | 1 | 1 | | MD2 | |
| | | | | 0 | | | | Mixing target | |
| | | | | 1 | | | | Speaker LF off | |
| | | | | | | | | Speaker LF on | |
| | | | | | | | | Speaker RF off | |
| | | | | | | | | Speaker RF on | |
| | | | 0 | | | | | Speaker LR off | |
| | | | 1 | | | | | Speaker LR on | |
| | 0 | 1 | | | | | | Speaker RR off | |
| | 1 | | | | | | | Speaker RR on | |
| 0 | | | | | | | | Stereo subw. using internal highpass filter | |
| 1 | | | | | | | | On | |
| | | | | | | | | Off | |

Table 19. Soft mute (6)

| MSB | | | | | | | LSB | | Function |
|------------------|------------------|----------------|----------------|----------------|----------------|----------------|----------------|---|----------|
| D ₇ | D ₆ | D ₅ | D ₄ | D ₃ | D ₂ | D ₁ | D ₀ | | |
| | | | | | | | | SoftMute On (Mute) Off Mutetime = 0.48ms Mutetime = 0.96ms Mutetime = 123ms Mutetime = 324 ms | |
| | | | | 0 1 | | | | Influence on stereo decoder highohmic mute on off | |
| | | | 0 1 | | | | | Influence on pilot detector hold and MP hold on off | |
| | | 0 1 | | | | | | Influence on SoftMute on off | |
| 0 0 1 1 | 0 1 0 1 | | | | | | | Beep frequencies 600 Hz 780 Hz 1.56 kHz 2.4 kHz | |

Table 20. Voiceband (7)

| MSB | | | | | | | LSB | | Function |
|----------------|----------------|----------------|----------------|----------------|----------------|----------------|----------------|--|----------|
| D ₇ | D ₆ | D ₅ | D ₄ | D ₃ | D ₂ | D ₁ | D ₀ | | |
| | | | | | | | 0 1 | Voice band low pass enable Filter off Filter on | |
| | | | | | | 0 1 | | Voice band low pass frequency 3 kHz 6 kHz | |
| | | | | | 0 1 | | | Voice band high pass enable Filter off Filter on | |

Table 20. Voiceband (7) (continued)

| MSB | | | | | | | LSB | Function |
|----------------|----------------|--------------------------------------|--------------------------------------|--------------------------------------|----------------|----------------|----------------|--|
| D ₇ | D ₆ | D ₅ | D ₄ | D ₃ | D ₂ | D ₁ | D ₀ | |
| | | 0 0 0 1 1 1 1 1 | 0 0 1 1 0 0 1 1 | 0 1 0 1 0 1 0 1 | | | | High pass cut off frequency 90Hz 135Hz 180Hz 215Hz 300Hz 450Hz 600Hz 750Hz |
| | 0 1 | | | | | | | Anti clipping enable on off |
| 0 1 | | | | | | | | Anti clipping input MP-In AM |

Table 21. Second source selector (8)

| MSB | | | | | | | LSB | Function |
|----------------|-----------------------|-----------------------|-----------------------|-----------------------|--------------------------------------|--------------------------------------|--------------------------------------|---|
| D ₇ | D ₆ | D ₅ | D ₄ | D ₃ | D ₂ | D ₁ | D ₀ | |
| | | | | | 0 0 0 0 1 1 1 1 | 0 0 1 1 0 0 1 1 | 0 1 0 1 0 1 0 1 | Source selector FD1 / SE2 SE3 FD2 SE1 MD2 MD1 / SE4 stereo decoder AM |
| | 0 0 : 1 1 | 0 0 : 1 1 | 0 0 : 1 1 | 0 1 : 0 1 | | | | Input gain 0dB 1dB : 14dB 15dB |
| 0 1 | | | | | | | | Mute off on |

Table 22. Second loudness (9)

| MSB | | | | LSB | | | | Function |
|----------------|----------------|----------------|----------------|----------------|----------------|----------------|----------------|-------------------------------|
| D ₇ | D ₆ | D ₅ | D ₄ | D ₃ | D ₂ | D ₁ | D ₀ | |
| | | | 0 | 0 | 0 | 0 | 0 | Attenuation 0 dB |
| | | | 0 | 0 | 0 | 0 | 1 | -1 dB |
| | | | : | : | : | : | : | : |
| | | | 0 | 1 | 1 | 1 | 0 | -14 dB |
| | | | 0 | 1 | 1 | 1 | 1 | -15 dB |
| | | | : | : | : | : | : | : |
| | | | 1 | 0 | 0 | 1 | 1 | -19 dB |
| | | | : | : | : | : | : | not allowed |
| | 0 | 0 | | | | | | Center frequency 200Hz |
| | 0 | 1 | | | | | | 400Hz |
| | 1 | 0 | | | | | | 600Hz |
| | 1 | 1 | | | | | | 800Hz |
| 0 | | | | | | | | Loudness order First order |
| 1 | | | | | | | | Second order |

Table 23. Subwoofer Configuration / Bass (10)

| MSB | | | | LSB | | | | Function |
|----------------|----------------|----------------|----------------|----------------|----------------|----------------|----------------|--|
| D ₇ | D ₆ | D ₅ | D ₄ | D ₃ | D ₂ | D ₁ | D ₀ | |
| | | | | | | 0 | 0 | Subwoofer filter off |
| | | | | | | 0 | 1 | 80Hz |
| | | | | | | 1 | 0 | 120Hz |
| | | | | | | 1 | 1 | 160Hz |
| | | | | | 0 | | | Subwoofer outputs differential (mono) |
| | | | | | 1 | | | single ended (stereo) |
| | | | | 0 | | | | Subwoofer source Second source |
| | | | | 1 | | | | Main source |
| | | | 0 | | | | | Subwoofer phase 180° |
| | | | 1 | | | | | 0° |
| 0 | 0 | 0 | | | | | | Bass center frequency 60Hz |
| 0 | 0 | 1 | | | | | | 80Hz |
| 0 | 1 | 0 | | | | | | 70Hz |
| 0 | 1 | 1 | | | | | | 90Hz |
| 1 | 0 | 0 | | | | | | 100Hz |
| 1 | 0 | 1 | | | | | | 130Hz |
| 1 | 1 | 0 | | | | | | 150Hz |
| 1 | 1 | 1 | | | | | | 200Hz |

Table 24. Comander (11)

| MSB | | | | | | | LSB | | Function |
|----------------|----------------|----------------|----------------|----------------|----------------|----------------|----------------|--|----------|
| D ₇ | D ₆ | D ₅ | D ₄ | D ₃ | D ₂ | D ₁ | D ₀ | | |
| | | | | | | 0 | 0 | Activity / reference level off | |
| | | | | | | 0 | 1 | 0.5V _{RMS} | |
| | | | | | | 1 | 0 | 1V _{RMS} | |
| | | | | | | 1 | 1 | 2V _{RMS} | |
| | | | | 0 | 0 | | | Attack-times 6ms | |
| | | | | 0 | 1 | | | 12ms | |
| | | | | 1 | 0 | | | 24ms | |
| | | | | 1 | 1 | | | 49ms | |
| | | 0 | 0 | | | | | Release-times 390ms | |
| | | 0 | 1 | | | | | 780ms | |
| | | 1 | 0 | | | | | 1.17s | |
| | | 1 | 1 | | | | | 1.56s | |
| | 0 | | | | | | | SoftStep-time¹⁾ 160μs | |
| | 0 | | | | | | | 320μs | |
| | 0 | | | 0 | 0 | | | 640μs | |
| | 0 | | | 0 | 1 | | | 1.28ms | |
| | 1 | 0 | 0 | 1 | 0 | | | 2.56ms | |
| | 1 | 0 | 1 | 1 | 1 | | | 5.12ms | |
| | 1 | 1 | 0 | | | | | 10.2ms | |
| | 1 | 1 | 1 | | | | | 20.4ms | |
| 0 | | | | | | | | Comander max. gain 29dB | |
| 1 | | | | | | | | 19dB | |

Note: The SoftStep times are only programmable while the comander is not in use.

Table 25. Configuration audioprocessor I (12)

| MSB | | | | | | | LSB | | Function |
|----------------|----------------|----------------|----------------|----------------|----------------|----------------|----------------|----------------------------------|----------|
| D ₇ | D ₆ | D ₅ | D ₄ | D ₃ | D ₂ | D ₁ | D ₀ | | |
| | | | | | | | 0 | Comander source Main selector | |
| | | | | | | | 1 | Second source selector | |
| | | | | | | 0 | | SoftStep off | |
| | | | | | | 1 | | on | |

Table 25. Configuration audioprocessor I (12) (continued)

| MSB | | | | LSB | | | | Function |
|------------------|------------------|------------------|------------------|----------------|----------------|----------------|----------------|--|
| D ₇ | D ₆ | D ₅ | D ₄ | D ₃ | D ₂ | D ₁ | D ₀ | |
| | | | | | 0 1 | | | Main loudness flat Filter ON |
| | | | | 0 1 | | | | Second loudness flat Filter ON |
| | | 0 0 1 1 | 0 1 0 1 | | | | | Front speaker not allowed Second source internal coupled Main source AC coupled Main source internal coupled |
| 0 0 1 1 | 0 1 0 1 | | | | | | | Rear speaker not allowed Second source internal coupled Main source AC coupled Main source internal coupled |

Table 26. Configuration audioprocessor II (13)

| MSB | | | | LSB | | | | Function |
|----------------|----------------|------------------|------------------|----------------|------------------|------------------|----------------|---|
| D ₇ | D ₆ | D ₅ | D ₄ | D ₃ | D ₂ | D ₁ | D ₀ | |
| | | | | | | | 0 1 | Pause detector off on |
| | | | | | 0 0 1 1 | 0 1 0 1 | | Pause ZC window 160mV 80mV 40mV not allowed |
| | | | | 0 1 | | | | FD1 mode single ended differential |
| | | 0 0 1 1 | 0 1 0 1 | | | | | FD1 attenuation -12dB -6dB -6dB <u>0dB</u> |

Table 26. Configuration audioprocessor II (13) (continued)

| MSB | | | | | | | LSB | Function |
|----------------|----------------|----------------|----------------|----------------|----------------|----------------|----------------|--|
| D ₇ | D ₆ | D ₅ | D ₄ | D ₃ | D ₂ | D ₁ | D ₀ | |
| | 0 1 | | | | | | | FD2 attenuation -6dB 0dB |
| 0 1 | | | | | | | | MD1 mode single ended differential |

Table 27. Speaker, subwoofer and mixer level-control (14-20)

| MSB | | | | | | | LSB | Function |
|----------------|----------------|----------------|----------------|----------------|----------------|----------------|----------------|----------|
| D ₇ | D ₆ | D ₅ | D ₄ | D ₃ | D ₂ | D ₁ | D ₀ | |
| 1 | 0 | 0 | 0 | 1 | 1 | 1 | 1 | +15 dB |
| : | : | : | : | : | : | : | : | : |
| 1 | 0 | 0 | 0 | 0 | 0 | 0 | 1 | +1 dB |
| 1 | 0 | 0 | 0 | 0 | 0 | 0 | 0 | 0 dB |
| 0 | 0 | 0 | 0 | 0 | 0 | 0 | 0 | 0 dB |
| 0 | 0 | 0 | 0 | 0 | 0 | 0 | 1 | -1 dB |
| : | : | : | : | : | : | : | : | : |
| 0 | 0 | 0 | 0 | 1 | 1 | 1 | 1 | -15 dB |
| 0 | 0 | 0 | 1 | 0 | 0 | 0 | 0 | -16 dB |
| : | : | : | : | : | : | : | : | : |
| 0 | 1 | 0 | 0 | 1 | 1 | 1 | 0 | -78 dB |
| 0 | 1 | 0 | 0 | 1 | 1 | 1 | 1 | -79 dB |
| x | 1 | 1 | x | x | x | x | x | Mute |

The programming of all speaker, subwoofer and mixing level controls are the same.

Table 28. Testing Audioprocessor (21)

| MSB | | | | | | | LSB | Function |
|----------------|----------------|----------------|----------------|--------------------------------------|--------------------------------------|--------------------------------------|----------------|--|
| D ₇ | D ₆ | D ₅ | D ₄ | D ₃ | D ₂ | D ₁ | D ₀ | |
| | | | | | | | 0 1 | Audioprocessor testmode off on |
| | | | | 0 0 0 0 1 1 1 1 | 0 0 1 1 0 0 1 1 | 0 1 0 1 0 1 0 1 | | Test-multiplexer Compander log amp. output Compander low pass output Compander DAC output 200kHz oscillator not allowed not allowed NB-hold internal reference |
| | | | 0 1 | | | | | Compander testmode off on |
| | | 0 1 | | | | | | Clock external internal |
| | 0 1 | | | | | | | AZ function off on |
| 0 1 | | | | | | | | SC-clock Fast mode Normal mode |

Note: This byte is used for testing or evaluation purposes only and must not set to other values than "11101110" in the application!

Table 29. Stereo decoder (22)

| MSB | | | | | | | LSB | Function |
|----------------|----------------|----------------|----------------|----------------|------------------|------------------|----------------|---|
| D ₇ | D ₆ | D ₅ | D ₄ | D ₃ | D ₂ | D ₁ | D ₀ | |
| | | | | | | | 0 1 | STD unmuted STD muted |
| | | | | | 0 0 1 1 | 0 1 0 1 | | IN-gain 11 dB IN-gain 8.5 dB IN-gain 6 dB IN-gain 3.5 dB |
| | | | | 0 1 | | | | Input AM pin Input MPX pin |

Table 29. Stereo decoder (22) (continued)

| MSB | | | | | | | LSB | Function |
|------------------|------------------|----------------|----------------|----------------|----------------|----------------|----------------|---|
| D ₇ | D ₆ | D ₅ | D ₄ | D ₃ | D ₂ | D ₁ | D ₀ | |
| | | | 0 1 | | | | | Forced MONO MONO/STEREO switch automatically |
| | | 0 1 | | | | | | Pilot threshold HIGH Pilot threshold LOW |
| 0 0 1 1 | 0 1 0 1 | | | | | | | De-emphasis 50µs (37.5µs ¹) De-emphasis 62.5µs (46.9µs ¹) De-emphasis 75µs (56.3µs ¹) De-emphasis 100µs (75µs ¹) |

Note: If De-emphasis-Shift enabled (Subaddr.26/Bit7 = 0)

Table 30. Noise blanker I (23)

| MSB | | | | | | | LSB | Function |
|------------------|------------------|------------------|------------------|--------------------------------------|--------------------------------------|--------------------------------------|----------------|--|
| D ₇ | D ₆ | D ₅ | D ₄ | D ₃ | D ₂ | D ₁ | D ₀ | |
| | | | | | | | 0 1 | Noise blanker off Noise blanker on |
| | | | | 0 0 0 0 1 1 1 1 | 0 0 1 1 0 0 1 1 | 0 1 1 0 1 0 1 1 | | Low threshold 65mV Low threshold 60mV Low threshold 55mV Low threshold 50mV Low threshold 45mV Low threshold 40mV Low threshold 35mV Low threshold 30mV |
| | | 0 0 1 1 | 0 1 0 1 | | | | | Noise controlled threshold 320mV Noise controlled threshold 260mV Noise controlled threshold 200mV Noise controlled threshold 140mV |
| 0 0 1 1 | 0 1 0 1 | | | | | | | Overdeviation adjust 2.8V Overdeviation adjust 2.0V Overdeviation adjust 1.2V Overdeviation detector OFF |

Table 31. Noiseblanker II (24)

| MSB | | | | | | | LSB | Function |
|----------------|----------------|----------------|----------------|----------------|----------------|----------------|----------------|--|
| D ₇ | D ₆ | D ₅ | D ₄ | D ₃ | D ₂ | D ₁ | D ₀ | |
| | | | | | | | 0 | PEAK charge current low |
| | | | | | | | 1 | high |
| | | | | | 0 | 0 | | Fieldstrength adjust 2.3V |
| | | | | | 0 | 1 | | 1.8V |
| | | | | | 1 | 0 | | 1.3V |
| | | | | | 1 | 1 | | OFF |
| | | | 0 | 0 | | | | Blank Time FM / AM 38µs / 1.2ms |
| | | | 0 | 1 | | | | 25.5µs / 800µs |
| | | | 1 | 0 | | | | 32µs / 1.0s |
| | | | 1 | 1 | | | | 22µs / 640µs |
| | 0 | 0 | | | | | | Noise rectifier discharge resistor R = infinite |
| | 0 | 1 | | | | | | R _{DC} = 56k |
| | 1 | 0 | | | | | | R _{DC} = 33k |
| | 1 | 1 | | | | | | R _{DC} = 18k |
| 0 | | | | | | | | Strong multipath influence on PEAK 18k off |
| 1 | | | | | | | | on (18k discharge if V _{MPout} < 2.5V) |

Table 32. AM / FM noiseblanker (25)

| MSB | | | | | | | LSB | Function |
|----------------|----------------|----------------|----------------|----------------|----------------|----------------|----------------|---------------------------|
| D ₇ | D ₆ | D ₅ | D ₄ | D ₃ | D ₂ | D ₁ | D ₀ | |
| | | | | | | | 0 | Stereo decoder mode FM |
| | | | | | | | 1 | AM |
| | | | | 0 | 0 | 0 | | AM rectifier gain 6dB |
| | | | | 0 | 0 | 1 | | 8dB |
| | | | | 0 | 1 | 0 | | 10dB |
| | | | | 0 | 1 | 1 | | 12dB |
| | | | | 1 | 0 | 0 | | 14dB |
| | | | | 1 | 0 | 1 | | 16dB |
| | | | | 1 | 1 | 0 | | 18dB |
| | | | | 1 | 1 | 1 | | 20dB |

Table 32. AM / FM noiseblanker (25) (continued)

| MSB | | | | | | | LSB | Function |
|----------------|----------------|----------------|----------------|----------------|----------------|----------------|----------------|-----------------------------|
| D ₇ | D ₆ | D ₅ | D ₄ | D ₃ | D ₂ | D ₁ | D ₀ | |
| | | 0 | 0 | | | | | Rectifier cut off frequency |
| | | 0 | 1 | | | | | 14.0kHz |
| | | 1 | 0 | | | | | 18.5kHz |
| | | 1 | 1 | | | | | 28.0kHz |
| | | | | | | | | 56.0kHz |
| 1 | 1 | | | | | | | must be "1" |

Table 33. High cut (26)

| MSB | | | | | | | LSB | Function |
|----------------|----------------|----------------|----------------|----------------|----------------|----------------|----------------|-------------------|
| D ₇ | D ₆ | D ₅ | D ₄ | D ₃ | D ₂ | D ₁ | D ₀ | |
| | | | | | | | 0 | High cut off |
| | | | | | | | 1 | on |
| | | | | | 0 | 0 | | max. high cut |
| | | | | | 0 | 1 | | 2dB |
| | | | | | 1 | 0 | | 5dB |
| | | | | | 1 | 1 | | 7dB |
| | | | | | | | | 10dB |
| | | | 0 | 0 | | | | VHCH to be at |
| | | | 0 | 1 | | | | 42% REF5V |
| | | | 1 | 0 | | | | 50% REF5V |
| | | | 1 | 1 | | | | 58% REF5V |
| | | | | | | | | 66% REF5V |
| | 0 | 0 | | | | | | VHCL to be at |
| | 0 | 1 | | | | | | 16.7% VHCH |
| | 1 | 0 | | | | | | 22.2% VHCH |
| | 1 | 1 | | | | | | 27.8% VHCH |
| | | | | | | | | 33.3% VHCH |
| 0 | | | | | | | | De-emphasis shift |
| 1 | | | | | | | | On |
| | | | | | | | | Off |

Table 34. Fieldstrength control (27)

| MSB | | | | LSB | | | | Function |
|----------------|----------------|----------------|----------------|----------------|----------------|----------------|----------------|--|
| D ₇ | D ₆ | D ₅ | D ₄ | D ₃ | D ₂ | D ₁ | D ₀ | |
| | | | | 0 | 0 | 0 | 0 | VSBL to be at 20.0% REF5V |
| | | | | 0 | 0 | 0 | 1 | 23.3% REF5V |
| | | | | 0 | 0 | 1 | 0 | 26.6% REF5V |
| | | | | 0 | 0 | 1 | 1 | 30.0% REF5V |
| | | | | 0 | 1 | 0 | 0 | 33.3% REF5V |
| | | | | 0 | 1 | 0 | 1 | 36.6% REF5V |
| | | | | 0 | 1 | 1 | 0 | 40.0% REF5V |
| | | | | 0 | 1 | 1 | 1 | 43.3% REF5V |
| | | | | 1 | 0 | 0 | 0 | 46.6% REF5V |
| | | | | 1 | 0 | 0 | 1 | 50.0% REF5V |
| | | | | 1 | 0 | 1 | 0 | 53.3% REF5V |
| | | | | 1 | 0 | 1 | 1 | 56.6% REF5V |
| | | | | 1 | 1 | 0 | 0 | 60.0% REF5V |
| | | | | 1 | 1 | 0 | 1 | 63.3% REF5V |
| | | | | 1 | 1 | 1 | 0 | 66.6% REF5V |
| | | | | 1 | 1 | 1 | 1 | 70.0% REF5V |
| | | 0 | 0 | | | | | Quality detector co-efficient a=0.7 |
| | | 0 | 1 | | | | | a=0.85 |
| | | 1 | 0 | | | | | a=1.0 |
| | | 1 | 1 | | | | | a=1.15 |
| 0 | 0 | | | | | | | HCC level shift (only level through MPD) 0.0V |
| 0 | 1 | | | | | | | 500mV |
| 1 | 0 | | | | | | | 1.0 V |
| 1 | 1 | | | | | | | 1.5 V |

Table 35. Multipath detector (28)

| MSB | | | | LSB | | | | Function |
|----------------|----------------|----------------|----------------|----------------|----------------|----------------|----------------|----------------------|
| D ₇ | D ₆ | D ₅ | D ₄ | D ₃ | D ₂ | D ₁ | D ₀ | |
| | | | | | | | 0 | Fast Load on |
| | | | | | | | 1 | off |
| | | | | | 0 | 0 | | Bandpass Gain 6dB |
| | | | | | 0 | 1 | | 12dB |
| | | | | | 1 | 0 | | 16dB |
| | | | | | 1 | 1 | | 18dB |

Table 35. Multipath detector (28) (continued)

| MSB | | | | LSB | | | | Function |
|----------------|----------------|----------------|------------------|------------------|----------------|----------------|----------------|--|
| D ₇ | D ₆ | D ₅ | D ₄ | D ₃ | D ₂ | D ₁ | D ₀ | |
| | | | 0 0 1 1 | 0 1 0 1 | | | | Rectifier gain Gain = 7.6dB Gain = 4.6dB Gain = 0dB disabled |
| | | 0 1 | | | | | | Charge current at MP out 0.25µA 0.50µA |
| | 0 1 | | | | | | | Multipath on high cut decay time 2ms 10ms |
| 0 1 | | | | | | | | Multipath influence on PEAK discharge off -1V/ms |

Table 36. Stereo decoder adjustment (29)

| MSB | | | | LSB | | | | Function |
|---------------------------------|-----------------------|-----------------------|-----------------------|-----------------------|---------------------------------|---------------------------------|---------------------------------|--|
| D ₇ | D ₆ | D ₅ | D ₄ | D ₃ | D ₂ | D ₁ | D ₀ | |
| 0 0 0 : 0 : 0 | | | | | 0 0 0 : 1 : 1 | 0 0 1 : 0 : 1 | 0 1 0 : 0 : 1 | Roll off compensation not allowed 7.2% 9.4% : 13.7% : 20.2% |
| 1 1 1 : 1 : 1 | | | | | 0 0 0 : 1 : 1 | 0 0 1 : 0 : 1 | 0 1 0 : 0 : 1 | not allowed 19.6% 21.5% : 25.3% : 31.0% |
| | 0 0 0 : 1 | 0 0 0 : 1 | 0 0 1 : 1 | 0 1 0 : 1 | | | | LEVEL gain 0dB 0.4dB 0.8dB : 6dB |

Table 37. Stereo decoder configuration (30)

| MSB | | | | | | | LSB | | Function |
|----------------|----------------|----------------|----------------|----------------|----------------|----------------|----------------|---|----------|
| D ₇ | D ₆ | D ₅ | D ₄ | D ₃ | D ₂ | D ₁ | D ₀ | | |
| | | | | | | | 0 1 | Multipath influence on high cut On Off | |
| | | | | | | 0 1 | | Multipath influence on stereo blend On Off | |
| | | | | | 0 1 | 1 x | 1 x | Level input over multipath detector¹ On Off | |
| | | | | 0 1 | | | | Dual MPX mode On Off | |
| 1 | 1 | 1 | 1 | 1 | | | | must be "1" | |

Note: Using the multipath time-constants for stereo bland and high cut

Table 38. Testing stereo decoder (31)

| MSB | | | | | | | LSB | | Function |
|----------------|----------------|----------------|----------------|----------------|----------------|----------------|----------------|--------------------------------------|----------|
| D ₇ | D ₆ | D ₅ | D ₄ | D ₃ | D ₂ | D ₁ | D ₀ | | |
| | | | | | | | 0 1 | Main testmode off on | |
| | | | | | | 0 1 | | stereo decoder testmode off on | |

Table 38. Testing stereo decoder (31) (continued)

| MSB | | | | | | | LS B | Function |
|----------------|----------------|----------------|----------------|----------------|----------------|----------------|----------------|-----------------------------|
| D ₇ | D ₆ | D ₅ | D ₄ | D ₃ | D ₂ | D ₁ | D ₀ | |
| | | 0 | 0 | 0 | 0 | | | Test signals |
| | | 0 | 0 | 0 | 1 | | | F228 |
| | | 0 | 0 | 1 | 0 | | | NB threshold |
| | | 0 | 0 | 1 | 1 | | | Level for stereo blend |
| | | 0 | 1 | 0 | 0 | | | Pilot magnitude |
| | | 0 | 1 | 0 | 1 | | | VHCCL |
| | | 0 | 1 | 1 | 0 | | | Pilot threshold |
| | | 0 | 1 | 1 | 1 | | | VHCCH |
| | | 1 | 0 | 0 | 0 | | | REF5V |
| | | 1 | 0 | 0 | 1 | | | HOLDN |
| | | 1 | 0 | 1 | 0 | | | NB peak |
| | | 1 | 0 | 1 | 1 | | | AM rectifier |
| | | 1 | 1 | 0 | 0 | | | VCOCON; VCO control voltage |
| | | 1 | 1 | 0 | 1 | | | VSBL |
| | | 1 | 1 | 1 | 0 | | | Pilot threshold |
| | | 1 | 1 | 1 | 1 | | | Level for high cut |
| | | 1 | 1 | 1 | 1 | | | REF5V |
| | 0 | | | | | | | Audioprocessor oscillator |
| | 1 | | | | | | | Off |
| | | | | | | | | On |
| 1 | | | | | | | | must be "1" |

Note: This byte is used for testing or evaluation purposes only and must not set to other values than "1111100" in the application!

10 Application information

Figure 37. Application diagram (standard configuration)

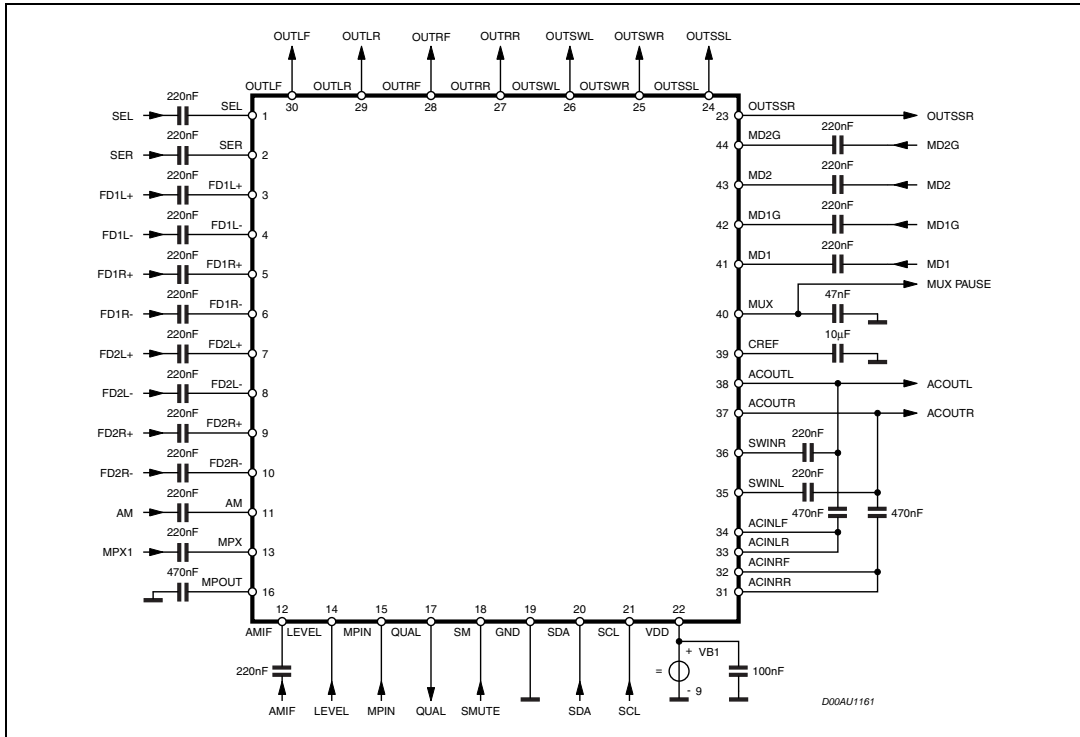
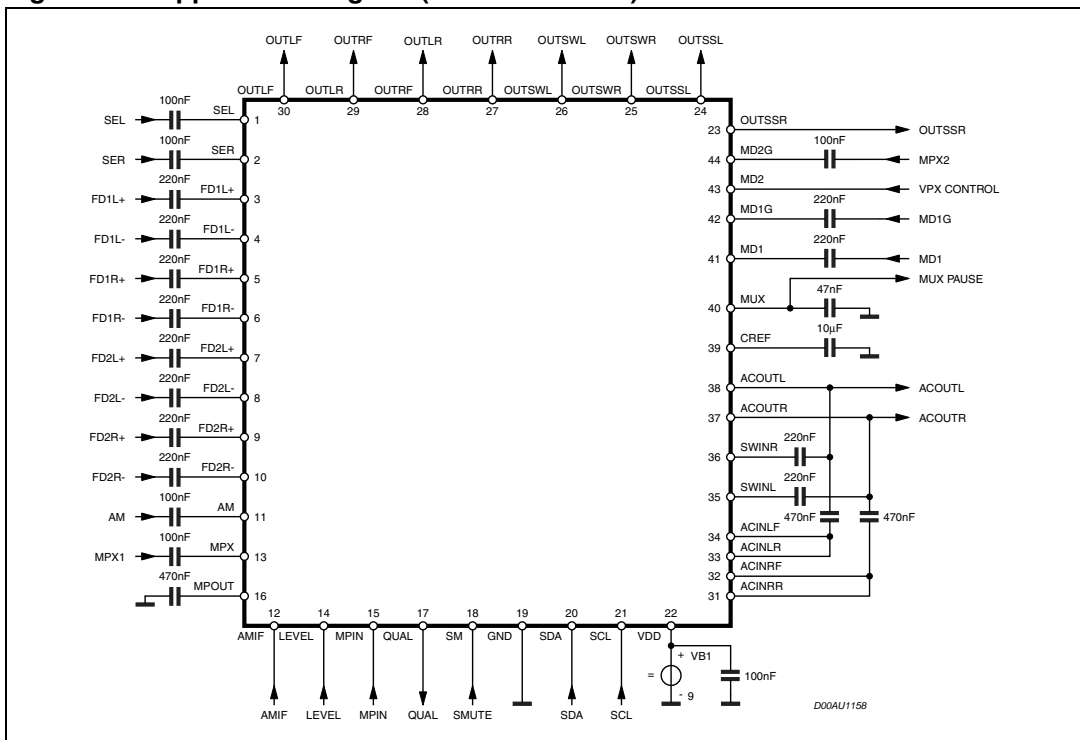

Figure 38. Application diagram (Dual MPX mode)



11 Package information

In order to meet environmental requirements, ST offers these devices in ECOPACK® packages. These packages have a lead-free second level interconnect. The category of second level interconnect is marked on the package and on the inner box label, in compliance with JEDEC standard JESD97. The maximum ratings related to soldering conditions are also marked on the inner box label. ECOPACK is an ST trademark. ECOPACK specifications are available at: www.st.com.

Figure 39. LQFP44 (10x10) Mechanical data and package dimensions

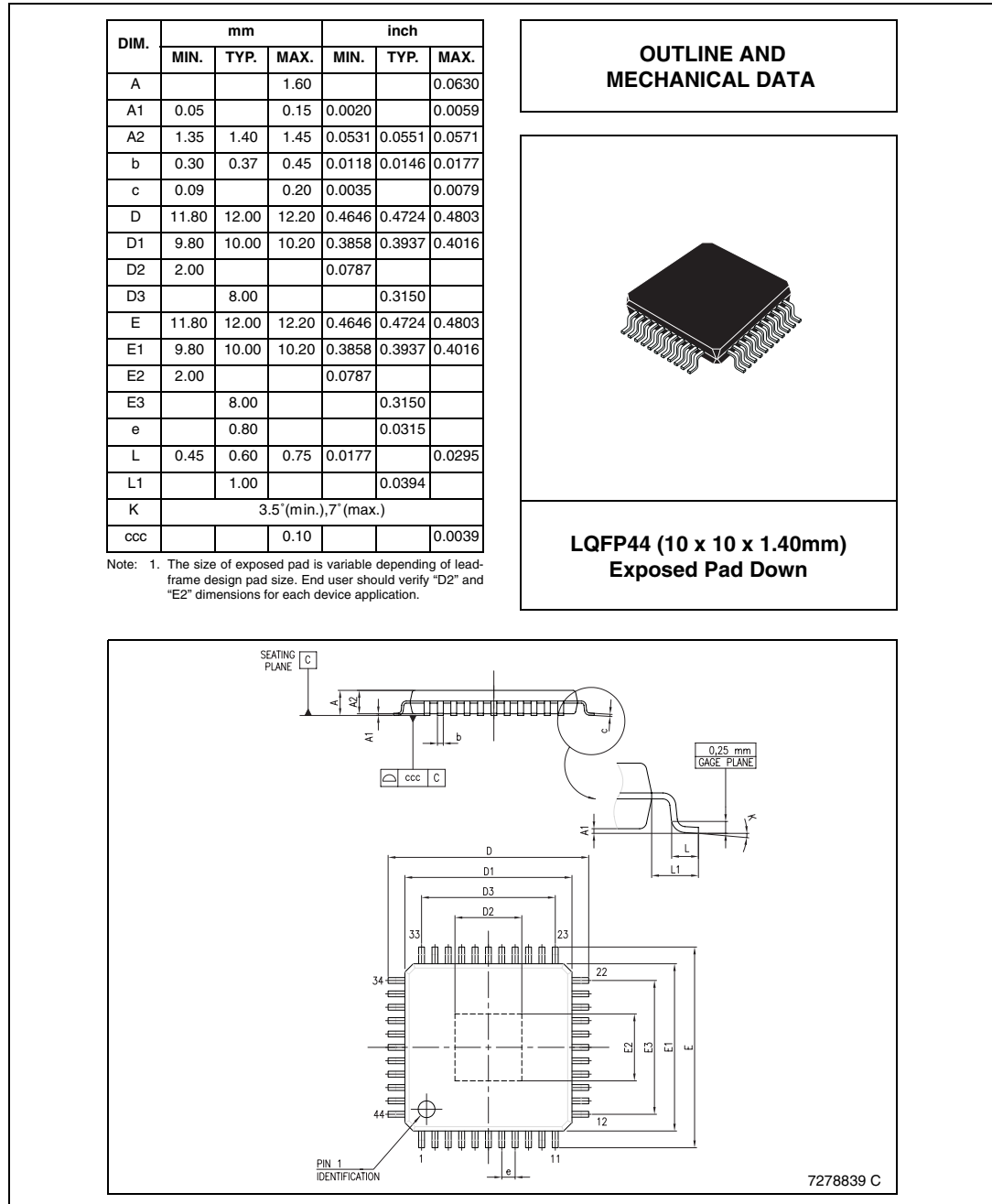

12 Revision history

Table 39. Document revision history

| Date | Revision | Changes |
|-------------|-----------------|--|
| 26-Apr-02 | 1 | Initial release |
| 21-Jun-04 | 2 | Technical migration from ST-PRESS to EDOCS |
| 26-Apr-04 | 3 | Revalidation |
| 26-Apr-06 | 4 | Repair document of typographical errors |
| 23-Mar-07 | 5 | Package change, layout change, text modifications. |

Please Read Carefully:

Information in this document is provided solely in connection with ST products. STMicroelectronics NV and its subsidiaries ("ST") reserve the right to make changes, corrections, modifications or improvements, to this document, and the products and services described herein at any time, without notice.

All ST products are sold pursuant to ST's terms and conditions of sale.

Purchasers are solely responsible for the choice, selection and use of the ST products and services described herein, and ST assumes no liability whatsoever relating to the choice, selection or use of the ST products and services described herein.

No license, express or implied, by estoppel or otherwise, to any intellectual property rights is granted under this document. If any part of this document refers to any third party products or services it shall not be deemed a license grant by ST for the use of such third party products or services, or any intellectual property contained therein or considered as a warranty covering the use in any manner whatsoever of such third party products or services or any intellectual property contained therein.

UNLESS OTHERWISE SET FORTH IN ST'S TERMS AND CONDITIONS OF SALE ST DISCLAIMS ANY EXPRESS OR IMPLIED WARRANTY WITH RESPECT TO THE USE AND/OR SALE OF ST PRODUCTS INCLUDING WITHOUT LIMITATION IMPLIED WARRANTIES OF MERCHANTABILITY, FITNESS FOR A PARTICULAR PURPOSE (AND THEIR EQUIVALENTS UNDER THE LAWS OF ANY JURISDICTION), OR INFRINGEMENT OF ANY PATENT, COPYRIGHT OR OTHER INTELLECTUAL PROPERTY RIGHT.

UNLESS EXPRESSLY APPROVED IN WRITING BY AN AUTHORIZED ST REPRESENTATIVE, ST PRODUCTS ARE NOT RECOMMENDED, AUTHORIZED OR WARRANTED FOR USE IN MILITARY, AIR CRAFT, SPACE, LIFE SAVING, OR LIFE SUSTAINING APPLICATIONS, NOR IN PRODUCTS OR SYSTEMS WHERE FAILURE OR MALFUNCTION MAY RESULT IN PERSONAL INJURY, DEATH, OR SEVERE PROPERTY OR ENVIRONMENTAL DAMAGE. ST PRODUCTS WHICH ARE NOT SPECIFIED AS "AUTOMOTIVE GRADE" MAY ONLY BE USED IN AUTOMOTIVE APPLICATIONS AT USER'S OWN RISK.

Resale of ST products with provisions different from the statements and/or technical features set forth in this document shall immediately void any warranty granted by ST for the ST product or service described herein and shall not create or extend in any manner whatsoever, any liability of ST.

ST and the ST logo are trademarks or registered trademarks of ST in various countries.

Information in this document supersedes and replaces all information previously supplied.

The ST logo is a registered trademark of STMicroelectronics. All other names are the property of their respective owners.

© 2007 STMicroelectronics - All rights reserved

STMicroelectronics group of companies

Australia - Belgium - Brazil - Canada - China - Czech Republic - Finland - France - Germany - Hong Kong - India - Israel - Italy - Japan - Malaysia - Malta - Morocco - Singapore - Spain - Sweden - Switzerland - United Kingdom - United States of America

www.st.com

