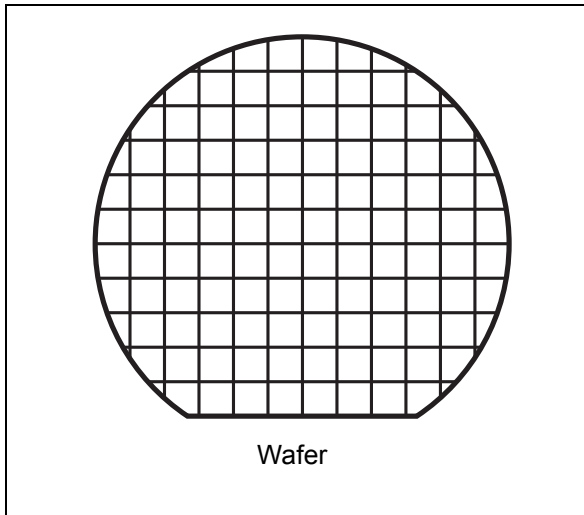

64 Kbit EEPROM tag IC at 13.56 MHz with 64-bit UID and password based on ISO/IEC 15693 and ISO/IEC 18000-3 Mode 1

Datasheet - production data

**Features**

- Based on ISO/IEC 15693 and ISO/IEC 18000-3 mode 1 standards
- 13.56 MHz \pm 7 kHz carrier frequency
- To tag: 10% or 100% ASK modulation using 1/4 (26 Kbit/s) or 1/256 (1.6 Kbit/s) pulse position coding
- From tag: load modulation using Manchester coding with 423 kHz and 484 kHz subcarriers in low (6.6 Kbit/s) or high (26 Kbit/s) data rate mode. Supports the 53 Kbit/s data rate with Fast commands
- Internal tuning capacitor (27.5 pF)
- More than 1 million write cycles
- More than 40-years data retention
- 64 Kbit EEPROM organized in 2048 blocks of 32 bits
- 64-bit unique identifier (UID)
- Multipassword protection
- Read Block & Write (32-bit blocks)
- Write time: 5.75 ms including the internal verify

Contents

1	Description	11
2	Signal description	11
2.1	Antenna coil (AC0, AC1)	11
3	User memory organization	12
4	System memory area	16
4.1	ST25TV64K RF block security	16
4.2	Example of the ST25TV64K security protection	18
5	Initial delivery state	19
6	Commands	20
6.1	Initial dialogue for vicinity cards	21
6.1.1	Power transfer	21
6.1.2	Frequency	21
6.1.3	Operating field	21
7	Communication signal from VCD to ST25TV64K	22
8	Data rate and data coding	24
8.1	Data coding mode: 1 out of 256	24
8.2	Data coding mode: 1 out of 4	25
8.3	VCD to ST25TV64K frames	27
8.4	Start of frame (SOF)	27
9	Communications signal from ST25TV64K to VCD	28
9.1	Load modulation	28
9.2	Subcarrier	28
9.3	Data rates	28
10	Bit representation and coding	29
10.1	Bit coding using one subcarrier	29

	10.1.1	High data rate	29
	10.1.2	Low data rate	30
	10.2	Bit coding using two subcarriers	31
	10.3	High data rate	31
	10.4	Low data rate	31
11		ST25TV64K to VCD frames	32
	11.1	SOF when using one subcarrier	32
	11.2	High data rate	32
	11.3	Low data rate	32
	11.4	SOF when using two subcarriers	33
	11.5	High data rate	33
	11.6	Low data rate	33
	11.7	EOF when using one subcarrier	34
	11.8	High data rate	34
	11.9	Low data rate	34
	11.10	EOF when using two subcarriers	35
	11.11	High data rate	35
	11.12	Low data rate	35
12		Unique identifier (UID)	36
13		Application family identifier (AFI)	37
14		Data storage format identifier (DSFID)	38
	14.1	CRC	38
15		ST25TV64K protocol description	39
16		ST25TV64K states	41
	16.1	Power-off state	41
	16.2	Ready state	41
	16.3	Quiet state	41
	16.4	Selected state	41

17	Modes	43
	17.1 Addressed mode	43
	17.2 Non-addressed mode (general request)	43
	17.3 Select mode	43
18	Request format	44
	18.1 Request flags	44
19	Response format	46
	19.1 Response flags	46
	19.2 Response error code	47
20	Anticollision	48
	20.1 Request parameters	48
21	Request processing by the ST25TV64K	50
22	Explanation of the possible cases	51
23	Inventory Initiated command	53
24	Timing definition	54
	24.1 t_1 : ST25TV64K response delay	54
	24.2 t_2 : VCD new request delay	54
	24.3 t_3 : VCD new request delay in the absence of a response from the ST25TV64K	54
25	Commands codes	55
	25.1 Inventory	56
	25.2 Stay Quiet	57
	25.3 Read Single Block	58
	25.4 Write Single Block	60
	25.5 Read Multiple Block	62
	25.6 Select	64
	25.7 Reset to Ready	65
	25.8 Write AFI	66

25.9	Lock AFI	68
25.10	Write DSFID	70
25.11	Lock DSFID	72
25.12	Get System Info	74
25.13	Get Multiple Block Security Status	76
25.14	Write-sector Password	78
25.15	Lock-Sector	80
25.16	Present-sector Password	82
25.17	Fast Read Single Block	84
25.18	Fast Inventory Initiated	86
25.19	Fast Initiate	87
25.20	Fast Read Multiple Block	88
25.21	Inventory Initiated	90
25.22	Initiate	91
26	Maximum ratings	92
27	RF electrical parameters	93
28	Part numbering	96
Appendix A	Anticollision algorithm	97
A.1	Algorithm for pulsed slots	97
Appendix B	CRC	98
B.1	CRC error detection method	98
B.2	CRC calculation example	98
Appendix C	Application family identifier (AFI)	101
	Revision history	102

List of tables

Table 1.	Signal names	11
Table 2.	Sector details	13
Table 3.	Sector security status byte area	16
Table 4.	Sector security status byte organization	16
Table 5.	Read / Write protection bit setting	17
Table 6.	Password Control bits	17
Table 7.	Password system area	17
Table 8.	Sector security protection after power-up	18
Table 9.	Sector security protection after a valid presentation of password 1	18
Table 10.	10% modulation parameters	22
Table 11.	Response data rates	28
Table 12.	UID format	36
Table 13.	CRC transmission rules	38
Table 14.	VCD request frame format	39
Table 15.	ST25TV64K Response frame format	39
Table 16.	ST25TV64K response depending on Request_flags	42
Table 17.	General request format	44
Table 18.	Definition of request flags 1 to 4	44
Table 19.	Request flags 5 to 8 when Bit 3 = 0	45
Table 20.	Request flags 5 to 8 when Bit 3 = 1	45
Table 21.	General response format	46
Table 22.	Definitions of response flags 1 to 8	46
Table 23.	Response error code definition	47
Table 24.	Inventory request format	48
Table 25.	Example of the addition of 0-bits to an 11-bit mask value	48
Table 26.	Timing values	54
Table 27.	Command codes	55
Table 28.	Inventory request format	56
Table 29.	Inventory response format	56
Table 30.	Stay Quiet request format	57
Table 31.	Read Single Block request format	58
Table 32.	Read Single Block response format when Error_flag is NOT set	58
Table 33.	Sector security status	58
Table 34.	Read Single Block response format when Error_flag is set	58
Table 35.	Write Single Block request format	60
Table 36.	Write Single Block response format when Error_flag is NOT set	60
Table 37.	Write Single Block response format when Error_flag is set	60
Table 38.	Read Multiple Block request format	62
Table 39.	Read Multiple Block response format when Error_flag is NOT set	62
Table 40.	Sector security status	62
Table 41.	Read Multiple Block response format when Error_flag is set	63
Table 42.	Select request format	64
Table 43.	Select Block response format when Error_flag is NOT set	64
Table 44.	Select response format when Error_flag is set	64
Table 45.	Reset to Ready request format	65
Table 46.	Reset to Ready response format when Error_flag is NOT set	65
Table 47.	Reset to ready response format when Error_flag is set	65
Table 48.	Write AFI request format	66

Table 49.	Write AFI response format when Error_flag is NOT set	66
Table 50.	Write AFI response format when Error_flag is set	66
Table 51.	Lock AFI request format	68
Table 52.	Lock AFI response format when Error_flag is NOT set	68
Table 53.	Lock AFI response format when Error_flag is set	68
Table 54.	Write DSFID request format	70
Table 55.	Write DSFID response format when Error_flag is NOT set	70
Table 56.	Write DSFID response format when Error_flag is set	70
Table 57.	Lock DSFID request format	72
Table 58.	Lock DSFID response format when Error_flag is NOT set	72
Table 59.	Lock DSFID response format when Error_flag is set	72
Table 60.	Get System Info request format	74
Table 61.	Get System Info response format when Protocol_extension_flag=0 and Error_flag is NOT set	74
Table 62.	Get System Info response format when Protocol_extension_flag=1 “and Error_flag is NOT set	74
Table 63.	Get System Info response format when Error_flag is set	75
Table 64.	Get Multiple Block Security Status request format	76
Table 65.	Get Multiple Block Security Status response format when Error_flag is NOT set	76
Table 66.	Sector security status	76
Table 67.	Get Multiple Block Security Status response format when Error_flag is set	77
Table 68.	Write-sector Password request format	78
Table 69.	Write-sector Password response format when Error_flag is NOT set	78
Table 70.	Write-sector Password response format when Error_flag is set	78
Table 71.	Lock-Sector request format	80
Table 72.	Sector security status	80
Table 73.	Lock-Sector response format when Error_flag is NOT set	80
Table 74.	Lock-Sector response format when Error_flag is set	80
Table 75.	Present-sector Password request format	82
Table 76.	Present-sector Password response format when Error_flag is NOT set	82
Table 77.	Present-sector Password response format when Error_flag is set	82
Table 78.	Fast Read Single Block request format	84
Table 79.	Fast Read Single Block response format when Error_flag is NOT set	84
Table 80.	Sector security status	84
Table 81.	Fast Read Single Block response format when Error_flag is set	84
Table 82.	Fast Inventory Initiated request format	86
Table 83.	Fast Inventory Initiated response format	86
Table 84.	Fast Initiate request format	87
Table 85.	Fast Initiate response format	87
Table 86.	Fast Read Multiple Block request format	88
Table 87.	Fast Read Multiple Block response format when Error_flag is NOT set	88
Table 88.	Sector security status if Option_flag is set	88
Table 89.	Fast Read Multiple Block response format when Error_flag is set	89
Table 90.	Inventory Initiated request format	90
Table 91.	Inventory Initiated response format	90
Table 92.	Initiate request format	91
Table 93.	Initiate Initiated response format	91
Table 94.	Absolute maximum ratings	92
Table 95.	RF characteristics	93
Table 96.	Operating conditions	94
Table 97.	Ordering information scheme	96
Table 98.	CRC definition	98

Table 99. AFI coding 101
Table 100. Document revision history 102

List of figures

Figure 1.	Pad connection	11
Figure 2.	Memory sector organization	12
Figure 3.	100% modulation waveform	22
Figure 4.	10% modulation waveform	23
Figure 5.	1 out of 256 coding mode	24
Figure 6.	Detail of a time period	25
Figure 7.	1 out of 4 coding mode	26
Figure 8.	1 out of 4 coding example.	26
Figure 9.	SOF to select 1 out of 256 data coding mode	27
Figure 10.	SOF to select 1 out of 4 data coding mode	27
Figure 11.	EOF for either data coding mode	27
Figure 12.	Logic 0, high data rate, one subcarrier	29
Figure 13.	Logic 0, high data rate, one subcarrier x2	29
Figure 14.	Logic 1, high data rate, one subcarrier	29
Figure 15.	Logic 1, high data rate, one subcarrier x2	29
Figure 16.	Logic 0, low data rate, one subcarrier.	30
Figure 17.	Logic 0, low data rate, one subcarrier x2	30
Figure 18.	Logic 1, low data rate, one subcarrier.	30
Figure 19.	Logic 1, low data rate, one subcarrier x2	30
Figure 20.	Logic 0, high data rate, two subcarriers	31
Figure 21.	Logic 1, high data rate, two subcarriers	31
Figure 22.	Logic 0, low data rate, two subcarriers	31
Figure 23.	Logic 1, low data rate, two subcarriers	31
Figure 24.	Start of frame, high data rate, one subcarrier	32
Figure 25.	Start of frame, high data rate, one subcarrier x2	32
Figure 26.	Start of frame, low data rate, one subcarrier	32
Figure 27.	Start of frame, low data rate, one subcarrier x2	33
Figure 28.	Start of frame, high data rate, two subcarriers	33
Figure 29.	Start of frame, low data rate, two subcarriers	33
Figure 30.	End of frame, high data rate, one subcarrier	34
Figure 31.	End of frame, high data rate, one subcarrier x2	34
Figure 32.	End of frame, low data rate, one subcarrier	34
Figure 33.	End of frame, low data rate, one subcarrier x2.	34
Figure 34.	End of frame, high data rate, two subcarriers.	35
Figure 35.	End of frame, low data rate, two subcarriers	35
Figure 36.	ST25TV64K decision tree for AFI	37
Figure 37.	ST25TV64K protocol timing	40
Figure 38.	ST25TV64K state transition diagram	42
Figure 39.	Principle of comparison between the mask, the slot number and the UID	49
Figure 40.	Description of a possible anticollision sequence	52
Figure 41.	Stay Quiet frame exchange between VCD and ST25TV64K	57
Figure 42.	Read Single Block frame exchange between VCD and ST25TV64K.	59
Figure 43.	Write Single Block frame exchange between VCD and ST25TV64K.	61
Figure 44.	Read Multiple Block frame exchange between VCD and ST25TV64K.	63
Figure 45.	Select frame exchange between VCD and ST25TV64K	64
Figure 46.	Reset to Ready frame exchange between VCD and ST25TV64K	65
Figure 47.	Write AFI frame exchange between VCD and ST25TV64K	67
Figure 48.	Lock AFI frame exchange between VCD and ST25TV64K	69

Figure 49.	Write DSFID frame exchange between VCD and ST25TV64K	71
Figure 50.	Lock DSFID frame exchange between VCD and ST25TV64K.....	73
Figure 51.	Get System Info frame exchange between VCD and ST25TV64K	75
Figure 52.	Get Multiple Block Security Status frame exchange between VCD and ST25TV64K	77
Figure 53.	Write-sector Password frame exchange between VCD and ST25TV64K	79
Figure 54.	Lock-Sector frame exchange between VCD and ST25TV64K.....	81
Figure 55.	Present-sector Password frame exchange between VCD and ST25TV64K	83
Figure 56.	Fast Read Single Block frame exchange between VCD and ST25TV64K.....	85
Figure 57.	Fast Initiate frame exchange between VCD and ST25TV64K	87
Figure 58.	Fast Read Multiple Block frame exchange between VCD and ST25TV64K.....	89
Figure 59.	Initiate frame exchange between VCD and ST25TV64K	91
Figure 60.	ASK modulated signal	95

1 Description

The ST25TV64K is a contactless memory powered by the received carrier electromagnetic wave, which follows the ISO/IEC 15693 and ISO/IEC 18000-3 mode 1 recommendation for radio-frequency power and signal interface. It is a 64 Kbit electrically erasable programmable memory (EEPROM). The memory is organized as 64 sectors divided into 32 blocks of 32 bits.

The ST25TV64K is accessed via the 13.56 MHz carrier electromagnetic wave, on which incoming data are demodulated from the received signal amplitude modulation (ASK: amplitude shift keying). The received ASK wave is 10% or 100% modulated with a data rate of 1.6 Kbit/s using the 1out of 256 pulse coding mode, or a data rate of 26 Kbit/s using the 1 out of 4 pulse coding mode. Outgoing data are generated by the ST25TV64K load variation using Manchester coding with one or two subcarrier frequencies at 423 kHz and 484 kHz. Data are transferred from the ST25TV64K at 6.6 Kbit/s in low data rate mode and 26 Kbit/s in high data rate mode. The ST25TV64K supports the 53 Kbit/s data rate in high data rate mode with a single subcarrier frequency of 423 kHz.

The ST25TV64K also features a unique 32-bits multi-password protection scheme.

Figure 1. Pad connection

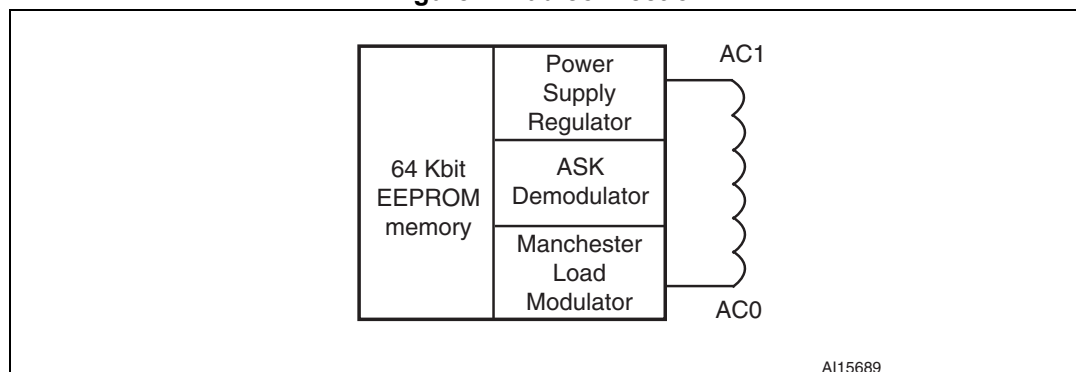

Table 1. Signal names

Signal name	Function	Direction
AC0	Antenna coil	I/O
AC1	Antenna coil	I/O

2 Signal description

2.1 Antenna coil (AC0, AC1)

These inputs are used to connect the device to an external coil exclusively. It is advised not to connect any other DC or AC signal to AC0 or AC1.

When correctly tuned, the coil is used to power and access the device using the ISO 15693 and ISO 18000-3 mode 1 protocols.

3 User memory organization

The ST25TV64K is divided into 64 sectors of 32 blocks of 32 bits as shown in [Table 2](#). [Figure 2](#) shows the memory sector organization. Each sector can be individually read-and/or write-protected using a specific password command. Read and write operations are possible if the addressed data are not in a protected sector.

The ST25TV64K also has a 64 bits block that is used to store the 64 bits unique identifier (UID). The UID is compliant with the ISO/IEC 15963 description, and its value is used during the anticollision sequence (Inventory). This block is not accessible by the user and its value is written by ST on the production line.

The ST25TV64K includes an AFI register that stores the application family identifier, and a DSFID register that stores the data storage family identifier used in the anticollision algorithm.

The ST25TV64K has three additional 32 bits blocks that store the RF password codes.

Figure 2. Memory sector organization

Sector	Area	Sector security status
0	1 kbit EEPROM sector	5 bits
1	1 kbit EEPROM sector	5 bits
2	1 kbit EEPROM sector	5 bits
3	1 kbit EEPROM sector	5 bits
⋮	⋮	⋮
60	1 kbit EEPROM sector	5 bits
61	1 kbit EEPROM sector	5 bits
62	1 kbit EEPROM sector	5 bits
63	1 kbit EEPROM sector	5 bits
	RF Password 1	System
	RF Password 2	System
	RF Password 3	System
	8 bits DSFID	System
	8 bits AFI	System
	64 bits UID	System

MS41421V1

Sector details

The ST25TV64K user memory is divided into 64 sectors. Each sector contains 1024 bits. The protection scheme is described in [Section 4: System memory area](#).

A sector provides 32 blocks of 32 bits. Each read and write access are done by block. Read and write block accesses are controlled by a Sector Security Status byte that defines the access rights to all the 32 blocks contained in the sector. If the sector is not protected, a Write command updates the complete 32 bits of the selected block.

Table 2. Sector details

Sector number	RF block address	Bits [31:24]	Bits [23:16]	Bits [15:8]	Bits [7:0]
0	0	user	user	user	user
	1	user	user	user	user
	2	user	user	user	user
	3	user	user	user	user
	4	user	user	user	user
	5	user	user	user	user
	6	user	user	user	user
	7	user	user	user	user
	8	user	user	user	user
	9	user	user	user	user
	10	user	user	user	user
	11	user	user	user	user
	12	user	user	user	user
	13	user	user	user	user
	14	user	user	user	user
	15	user	user	user	user
	16	user	user	user	user
	17	user	user	user	user
	18	user	user	user	user
	19	user	user	user	user
	20	user	user	user	user
	21	user	user	user	user
	22	user	user	user	user
	23	user	user	user	user
	24	user	user	user	user
	25	user	user	user	user
	26	user	user	user	user
	27	user	user	user	user
	28	user	user	user	user
	29	user	user	user	user
	30	user	user	user	user
	31	user	user	user	user

Table 2. Sector details (continued)

Sector number	RF block address	Bits [31:24]	Bits [23:16]	Bits [15:8]	Bits [7:0]
1	32	user	user	user	user
	33	user	user	user	user
	34	user	user	user	user
	35	user	user	user	user
	36	user	user	user	user
	37	user	user	user	user
	38	user	user	user	user
	39	user	user	user	user
...
...
63	2016	user	user	user	user
	2017	user	user	user	user
	2018	user	user	user	user
	2019	user	user	user	user
	2020	user	user	user	user
	2021	user	user	user	user
	2022	user	user	user	user
	2023	user	user	user	user
	2024	user	user	user	user
	2025	user	user	user	user
	2026	user	user	user	user
	2027	user	user	user	user
	2028	user	user	user	user
	2029	user	user	user	user
	2030	user	user	user	user
	2031	user	user	user	user
	2032	user	user	user	user
	2033	user	user	user	user
	2034	user	user	user	user
	2035	user	user	user	user
2036	user	user	user	user	
2037	user	user	user	user	
2038	user	user	user	user	
2039	user	user	user	user	



Table 2. Sector details (continued)

Sector number	RF block address	Bits [31:24]	Bits [23:16]	Bits [15:8]	Bits [7:0]
63 continued	2040	user	user	user	user
	2041	user	user	user	user
	2042	user	user	user	user
	2043	user	user	user	user
	2044	user	user	user	user
	2045	user	user	user	user
	2046	user	user	user	user
	2047	user	user	user	user

4 System memory area

4.1 ST25TV64K RF block security

The ST25TV64K provides a special protection mechanism based on passwords. Each memory sector of the ST25TV64K can be individually protected by one out of three available passwords, and each sector can also have Read/Write access conditions set.

Each memory sector of the ST25TV64K is assigned with a Sector security status byte including a Sector Lock bit, two Password Control bits and two Read/Write protection bits as shown in [Table 4](#). [Table 3](#) describes the organization of the Sector security status byte which can be read using the Read Single Block and Read Multiple Block commands with the Option_flag set to '1'.

On delivery, the default value of the SSS bytes is reset to 00h.

Table 3. Sector security status byte area

RF address	Bits [31:24]	Bits [23:16]	Bits [15:8]	Bits [7:0]
0	SSS 3	SSS 2	SSS 1	SSS 0
128	SSS 7	SSS 6	SSS 5	SSS 4
256	SSS 11	SSS 10	SSS 9	SSS 8
384	SSS 15	SSS 14	SSS 13	SSS 12
512	SSS 19	SSS 18	SSS 17	SSS 16
640	SSS 23	SSS 22	SSS 21	SSS 20
768	SSS 27	SSS 26	SSS 25	SSS 24
896	SSS 31	SSS 30	SSS 29	SSS 28
1024	SSS 35	SSS 34	SSS 33	SSS 32
1152	SSS 39	SSS 38	SSS 37	SSS 36
1280	SSS 43	SSS 42	SSS 41	SSS 40
1408	SSS 47	SSS 46	SSS 45	SSS 44
1536	SSS 51	SSS 50	SSS 49	SSS 48
1664	SSS 55	SSS 54	SSS 53	SSS 52
1792	SSS 59	SSS 58	SSS 57	SSS 56
1920	SSS 63	SSS 62	SSS 61	SSS 60

Table 4. Sector security status byte organization

b ₇	b ₆	b ₅	b ₄	b ₃	b ₂	b ₁	b ₀
0	0	0	Password Control bits		Read / Write protection bits		Sector Lock

When the Sector Lock bit is set to '1', for instance by issuing a Lock-Sector command, the 2 Read/Write protection bits (b₁, b₂) are used to set the Read/Write access of the sector as

described in [Table 5](#).

Table 5. Read / Write protection bit setting

Sector Lock	b ₂ , b ₁	Sector access when password presented		Sector access when password not presented	
		Read	Write	Read	Write
0	xx	Read	Write	Read	Write
1	00	Read	Write	Read	No Write
1	01	Read	Write	Read	Write
1	10	Read	Write	No Read	No Write
1	11	Read	No Write	No Read	No Write

The next 2 bits of the Sector security status byte (b₃, b₄) are the Password Control bits. The value these two bits is used to link a password to the sector as defined in [Table 6](#).

Table 6. Password Control bits

b ₄ , b ₃	Password
00	The sector is not protected by a Password
01	The sector is protected by the Password 1
10	The sector is protected by the Password 2
11	The sector is protected by the Password 3

The ST25TV64K password protection is organized around a dedicated set of commands plus a system area of three password blocks where the password values are stored. This system area is described in [Table 7](#).

Table 7. Password system area

Add	0	7	8	15	16	23	24	31
1	Password 1							
2	Password 2							
3	Password 3							

The dedicated password commands are:

- **Write-sector Password**

The Write-sector Password command is used to write a 32-bit block into the password system area. This command must be used to update password values. After the write cycle, the new password value is automatically activated. It is possible to modify a password value after issuing a valid Present-sector Password command. On delivery, the three default password values are set to 0000 0000h and are activated.

- **Lock-Sector**

The Lock-Sector command is used to set the Sector security status byte of the selected sector. Bits b₄ to b₁ of the Sector security status byte are affected by the Lock-Sector command. The Sector Lock bit, b₀, is set to '1' automatically. After issuing a Lock-

Sector command, the protection settings of the selected sector are activated. The protection of a locked block cannot be changed. A Lock-Sector command sent to a locked sector returns an error code.

- **Present-sector Password**

The Present-sector Password command is used to present one of the three passwords to the ST25TV64K in order to modify the access rights of all the memory sectors linked to that password (*Table 5*) including the password itself. If the presented password is correct, the access rights remain activated until the tag is powered off or until a new Present-sector Password command is issued. If the presented password value is not correct, all the access rights of all the memory sectors are deactivated.

4.2 Example of the ST25TV64K security protection

Table 8 and *Table 9* show the sector security protections before and after a valid Present-sector Password command. *Table 8* shows the sector access rights of an ST25TV64K after power-up. After a valid Present-sector Password command with password 1, the memory sector access is changed as shown in *Table 9*.

Table 8. Sector security protection after power-up

Sector address	Protection			Sector security status byte					
				b ₇ b ₆ b ₅	b ₄	b ₃	b ₂	b ₁	b ₀
0	Standard	Read	No Write	xxx	0	0	0	0	1
1	Pswd 1	Read	No Write	xxx	0	1	0	0	1
2	Pswd 1	Read	Write	xxx	0	1	0	1	1
3	Pswd 1	No Read	No Write	xxx	0	1	1	0	1
4	Pswd 1	No Read	No Write	xxx	0	1	1	1	1

Table 9. Sector security protection after a valid presentation of password 1

Sector address	Protection			Sector security status byte					
				b ₇ b ₆ b ₅	b ₄	b ₃	b ₂	b ₁	b ₀
0	Standard	Read	No Write	xxx	0	0	0	0	1
1	Pswd 1	Read	Write	xxx	0	1	0	0	1
2	Pswd 1	Read	Write	xxx	0	1	0	1	1
3	Pswd 1	Read	Write	xxx	0	1	1	0	1
4	Pswd 1	Read	No Write	xxx	0	1	1	1	1

5 Initial delivery state

The device is delivered with the following factory settings:

- All bits in the memory array are set to 1 (each byte contains FFh).
- The default value of the SSS bytes is reset to 00h.
- The three default password values are set to 0000 0000h and are activated.

System parameters are set to:

- (E0 02 xx xx xx xx xx xx)h for UID
- (03 07 FF)h for Memory Size
- 00h for AFI
- FFh for DSFID

6 Commands

The ST25TV64K supports the following commands:

- **Inventory**, used to perform the anticollision sequence.
- **Stay Quiet**, used to put the ST25TV64K in quiet mode, where it does not respond to any inventory command.
- **Select**, used to select the ST25TV64K. After this command, the ST25TV64K processes all Read/Write commands with Select_flag set.
- **Reset To Ready**, used to put the ST25TV64K in the ready state.
- **Read Block**, used to output the 32 bits of the selected block and its locking status.
- **Write Block**, used to write the 32-bit value in the selected block, provided that it is not locked.
- **Read Multiple Blocks**, used to read the selected blocks and send back their value.
- **Write AFI**, used to write the 8-bit value in the AFI register.
- **Lock AFI**, used to lock the AFI register.
- **Write DSFID**, used to write the 8-bit value in the DSFID register.
- **Lock DSFID**, used to lock the DSFID register.
- **Get System Info**, used to provide the system information value
- **Get Multiple Block Security Status**, used to send the security status of the selected block.
- **Initiate**, used to trigger the tag response to the Inventory Initiated sequence.
- **Inventory Initiated**, used to perform the anticollision sequence triggered by the Initiate command.
- **Write-sector Password**, used to write the 32 bits of the selected password.
- **Lock-Sector**, used to write the Sector security status bits of the selected sector.
- **Present-sector Password**, enables the user to present a password to unprotect the user blocks linked to this password.
- **Fast Initiate**, used to trigger the tag response to the Inventory Initiated sequence.
- **Fast Inventory Initiated**, used to perform the anticollision sequence triggered by the Initiate command.
- **Fast Read Single Block**, used to output the 32 bits of the selected block and its locking status.
- **Fast Read Multiple Blocks**, used to read the selected blocks and send back their value.

6.1 Initial dialogue for vicinity cards

The dialog between the vicinity coupling device (VCD) and the vicinity integrated circuit Card or VICC (ST25TV64K) takes place as follows:

- activation of the ST25TV64K by the RF operating field of the VCD.
- transmission of a command by the VCD.
- transmission of a response by the ST25TV64K.

These operations use the RF power transfer and communication signal interface described below (see [Power transfer](#), [Frequency](#) and [Operating field](#)). This technique is called RTF (Reader Talks First).

6.1.1 Power transfer

Power is transferred to the ST25TV64K by radio frequency at 13.56 MHz via coupling antennas in the ST25TV64K and the VCD. The RF operating field of the VCD is transformed on the ST25TV64K antenna to an AC Voltage which is rectified, filtered and internally regulated. The amplitude modulation (ASK) on this received signal is demodulated by the ASK demodulator.

6.1.2 Frequency

The ISO/IEC 15693 standard defines the carrier frequency (f_C) of the operating field as 13.56 MHz \pm 7 kHz.

6.1.3 Operating field

The ST25TV64K operates continuously between H_{min} and H_{max}

- the minimum operating field is H_{min} and has a value of 150 mA/m rms
- the maximum operating field is H_{max} and has a value of 5 A/m rms

A VCD shall generate a field comprised between the H_{min} and H_{max} values indicated in [Table 95: RF characteristics](#).

7 Communication signal from VCD to ST25TV64K

Communications between the VCD and the ST25TV64K takes place using the modulation principle of ASK (Amplitude Shift Keying). Two modulation indexes are used, 10% and 100%. The ST25TV64K decodes both. The VCD determines which index is used.

The modulation index is defined as $[a - b]/[a + b]$, where a is the peak signal amplitude and b the minimum signal amplitude of the carrier frequency.

Depending on the choice made by the VCD, a “pause” will be created as shown in [Figure 3](#) and [Figure 4](#).

The ST25TV64K is operational for any degree of modulation index from between 10% and 30%.

Figure 3. 100% modulation waveform

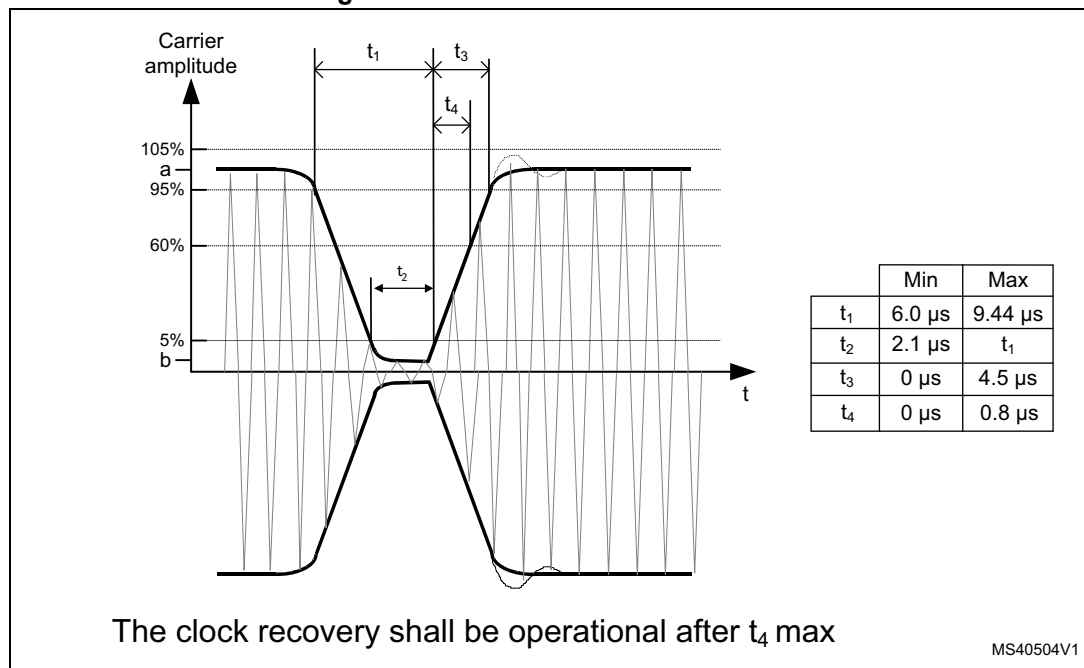
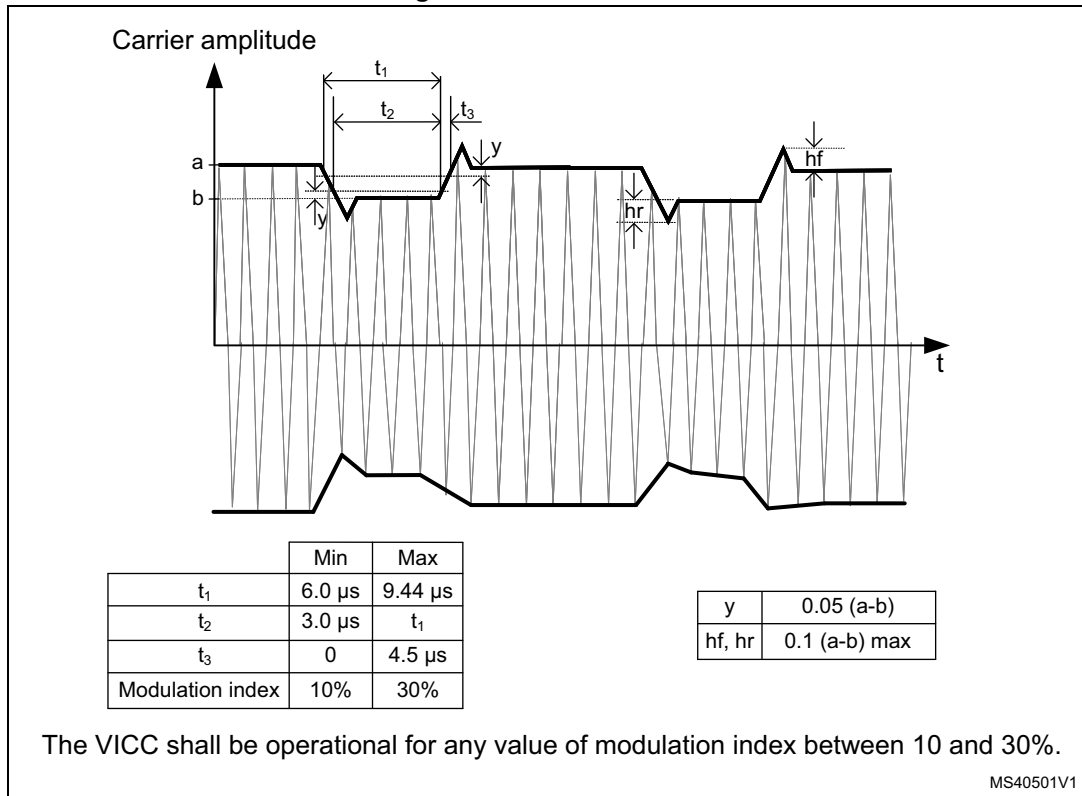

Table 10. 10% modulation parameters

Symbol	Parameter definition	Value
hr	$0.1 \times (a - b)$	Max
hf	$0.1 \times (a - b)$	Max

Figure 4. 10% modulation waveform



8 Data rate and data coding

The data coding implemented in the ST25TV64K uses pulse position modulation. Both data coding modes that are described in the ISO/IEC15693 are supported by the ST25TV64K. The selection is made by the VCD and indicated to the ST25TV64K within the start of frame (SOF).

8.1 Data coding mode: 1 out of 256

The value of one single byte is represented by the position of one pause. The position of the pause on one of 256 successive time periods of 18.88 μs ($256/f_C$), determines the value of the byte. In this case the transmission of one byte takes 4.833 ms and the resulting data rate is 1.65 kbits/s ($f_C/8192$).

Figure 5 illustrates this pulse position modulation technique. In this figure, data E1h (225 decimal) is sent by the VCD to the ST25TV64K.

The pause occurs during the second half of the position of the time period that determines the value, as shown in Figure 6.

A pause during the first period transmits the data value 00h. A pause during the last period transmit the data value FFh (255 decimal).

Figure 5. 1 out of 256 coding mode

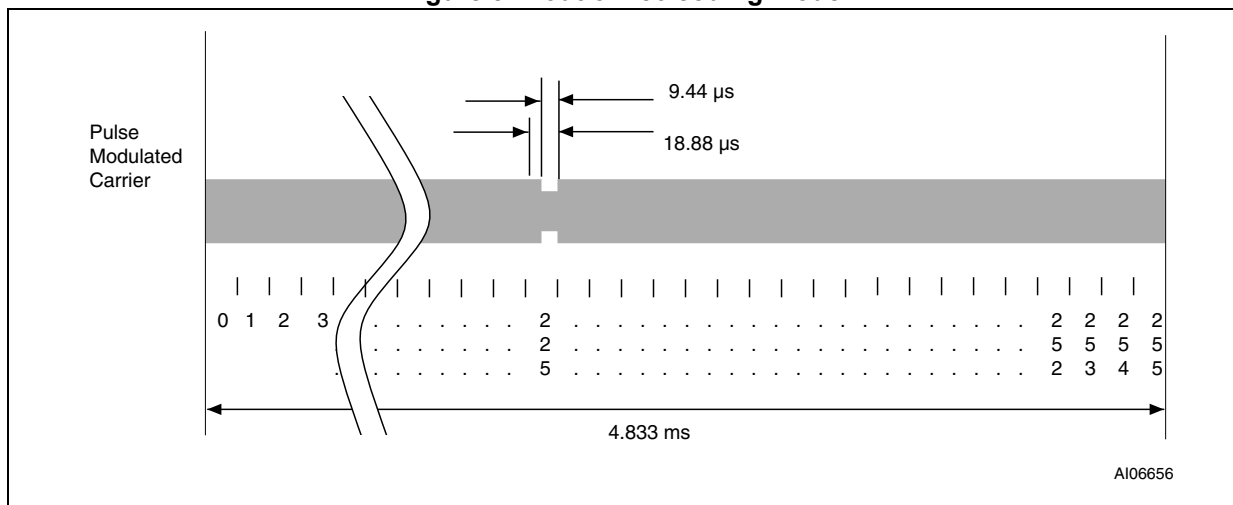
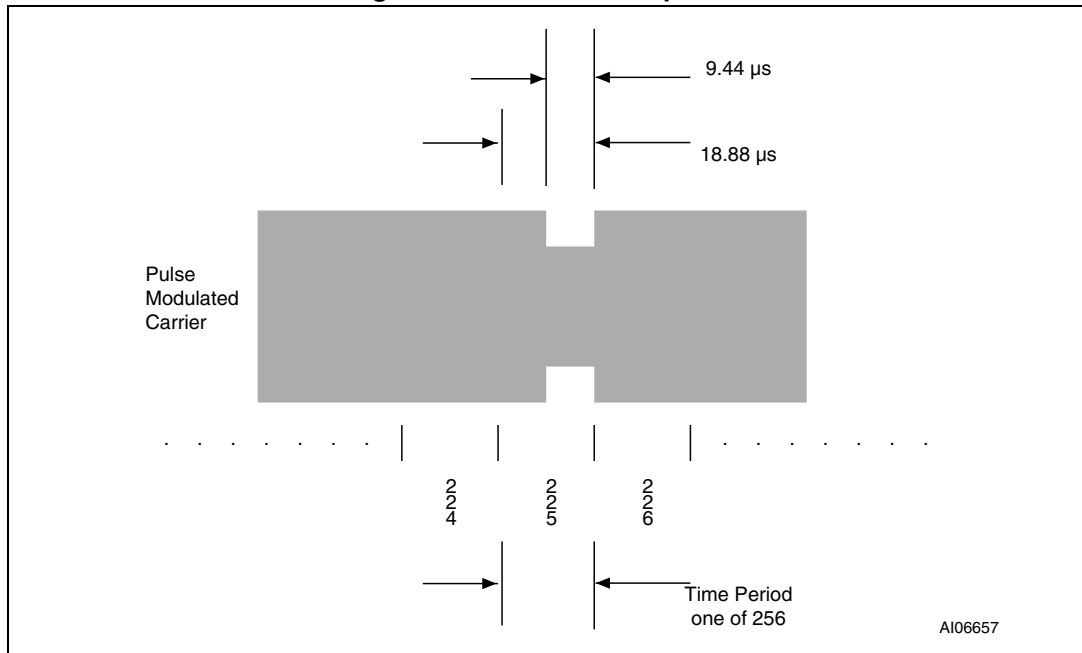

Figure 6. Detail of a time period



8.2 Data coding mode: 1 out of 4

The value of two bits is represented by the position of one pause. The position of the pause on one of 4 successive time periods of 18.88 μs ($256/f_C$), determines the value of the two bits. Four successive pairs of bits form a byte, where the least significant pair of bits is transmitted first.

In this case the transmission of one byte takes 302.08 μs and the resulting data rate is 26.48 Kbits/s ($f_C/512$). [Figure 7](#) illustrates the 1 out of 4 pulse position technique and coding. [Figure 8](#) shows the transmission of E1h (225d - 1110 0001b) by the VCD.

Figure 7. 1 out of 4 coding mode

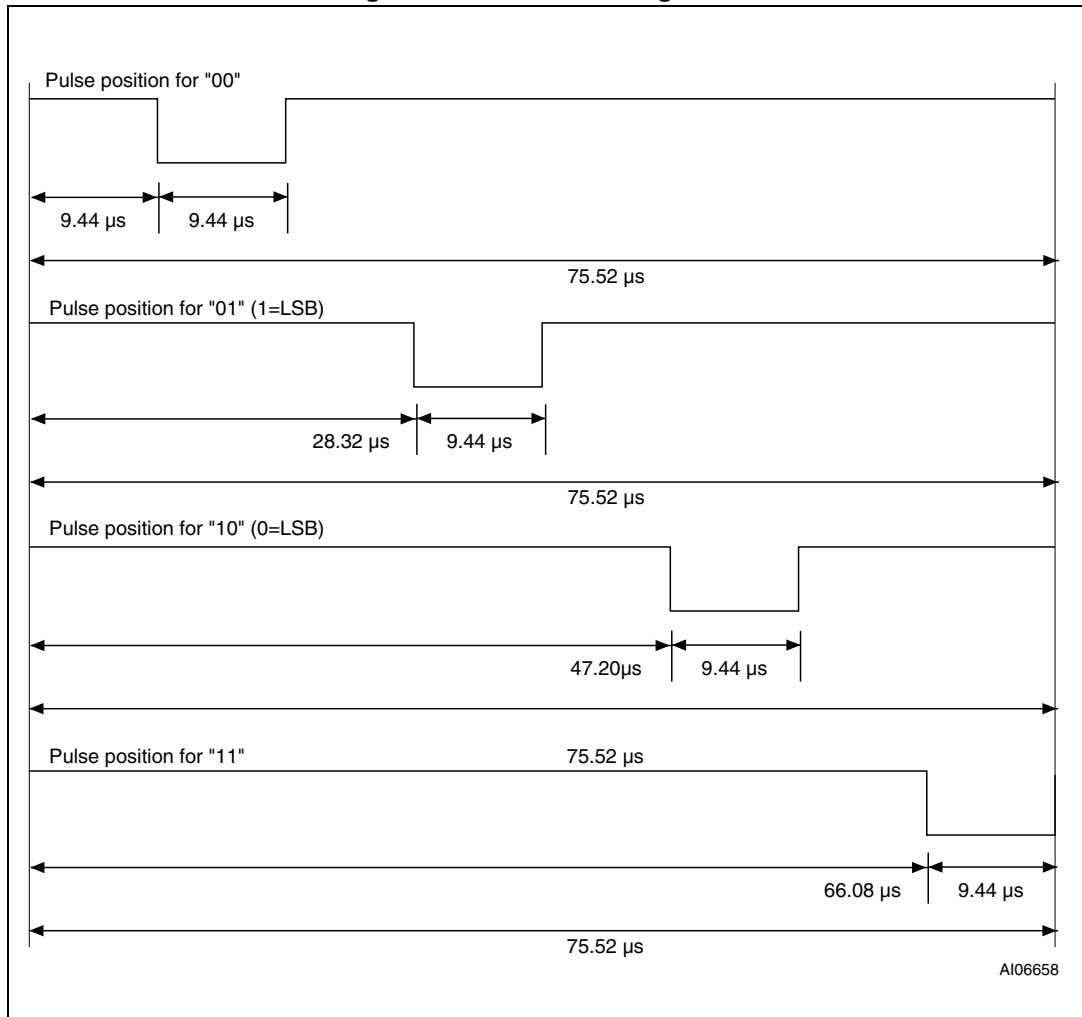
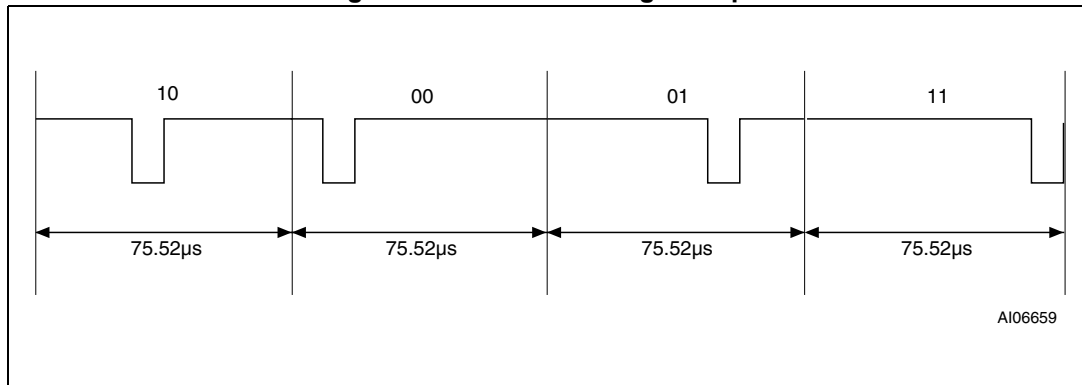

Figure 8. 1 out of 4 coding example



8.3 VCD to ST25TV64K frames

Frames are delimited by a start of frame (SOF) and an end of frame (EOF). They are implemented using code violation. Unused options are reserved for future use.

The ST25TV64K is ready to receive a new command frame from the VCD 311.5 μs (t_2) after sending a response frame to the VCD.

The ST25TV64K takes a power-up time of 0.1 ms after being activated by the powering field. After this delay, the ST25TV64K is ready to receive a command frame from the VCD.

8.4 Start of frame (SOF)

The SOF defines the data coding mode the VCD is to use for the following command frame. The SOF sequence described in [Figure 9](#) selects the 1 out of 256 data coding mode. The SOF sequence described in [Figure 10](#) selects the 1 out of 4 data coding mode. The EOF sequence for either coding mode is described in [Figure 11](#).

Figure 9. SOF to select 1 out of 256 data coding mode

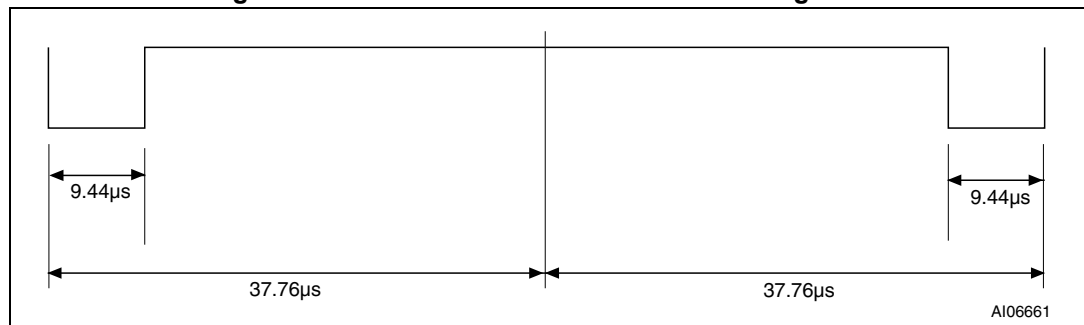

Figure 10. SOF to select 1 out of 4 data coding mode

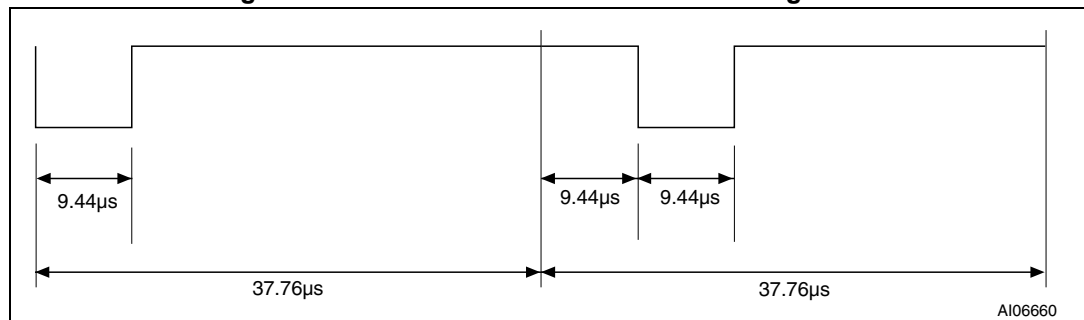
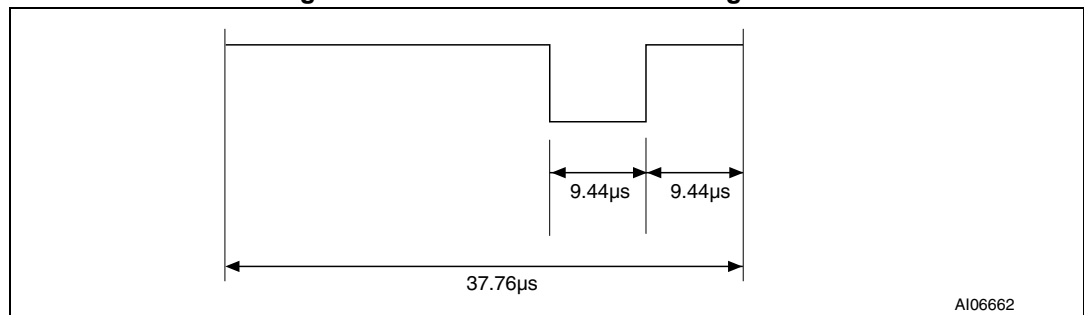

Figure 11. EOF for either data coding mode



9 Communications signal from ST25TV64K to VCD

The ST25TV64K has several modes defined for some parameters, owing to which it can operate in different noise environments and meet different application requirements.

9.1 Load modulation

The ST25TV64K is capable of communication to the VCD via an inductive coupling area whereby the carrier is loaded to generate a subcarrier with frequency f_S . The subcarrier is generated by switching a load in the ST25TV64K.

The load-modulated amplitude received on the VCD antenna must be of at least 10mV when measured as described in the test methods defined in International Standard ISO/IEC10373-7.

9.2 Subcarrier

The ST25TV64K supports the one-subcarrier and two-subcarriers response formats. These formats are selected by the VCD using the first bit in the protocol header. When one subcarrier is used, the frequency f_{S1} of the subcarrier load modulation is 423.75 kHz ($f_C/32$). When two subcarriers are used, the frequency f_{S1} is 423.75 kHz ($f_C/32$), and frequency f_{S2} is 484.28 kHz ($f_C/28$). When using the two-subcarriers mode, the ST25TV64K generates a continuous phase relationship between f_{S1} and f_{S2} .

9.3 Data rates

The ST25TV64K can respond using the low or the high data rate format. The selection of the data rate is made by the VCD using the second bit in the protocol header. It also supports the x2 mode available on all the Fast commands. [Table 11](#) shows the different data rates produced by the ST25TV64K using the different response format combinations.

Table 11. Response data rates

Data rate		One subcarrier	Two subcarriers
Low	Standard commands	6.62 Kbit/s ($f_C/2048$)	6.67 Kbit/s ($f_C/2032$)
	Fast commands	13.24 Kbit/s ($f_C/1024$)	not applicable
High	Standard commands	26.48 Kbit/s ($f_C/512$)	26.69 Kbit/s ($f_C/508$)
	Fast commands	52.97 Kbit/s ($f_C/256$)	not applicable

10 Bit representation and coding

Data bits are encoded using Manchester coding, according to the following schemes. For the low data rate, same subcarrier frequency or frequencies is/are used, in this case the number of pulses is multiplied by 4 and all times will increase by this factor. For the Fast commands using one subcarrier, all pulse numbers and times are divided by 2.

10.1 Bit coding using one subcarrier

10.1.1 High data rate

A logic 0 starts with eight pulses at 423.75 kHz ($f_C/32$) followed by an unmodulated time of 18.88 μs as shown in [Figure 12](#).

Figure 12. Logic 0, high data rate, one subcarrier

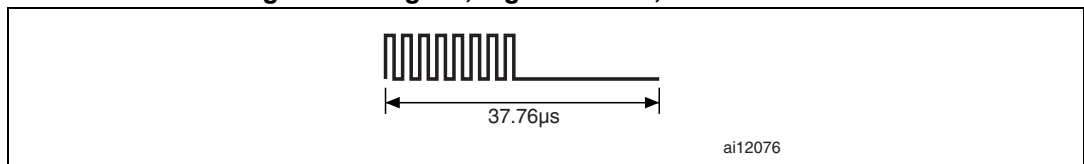

For the fast commands, a logic 0 starts with four pulses at 423.75 kHz ($f_C/32$) followed by an unmodulated time of 9.44 μs as shown in [Figure 13](#).

Figure 13. Logic 0, high data rate, one subcarrier x2

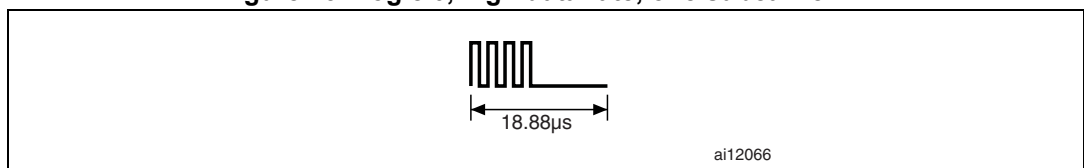

A logic 1 starts with an unmodulated time of 18.88 μs followed by eight pulses at 423.75 kHz ($f_C/32$) as shown in [Figure 14](#).

Figure 14. Logic 1, high data rate, one subcarrier

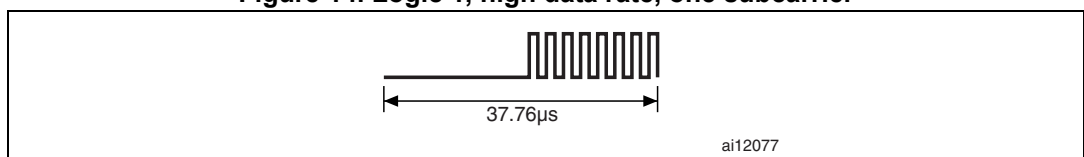

For the Fast commands, a logic 1 starts with an unmodulated time of 9.44 μs followed by four pulses of 423.75 kHz ($f_C/32$) as shown in [Figure 15](#).

Figure 15. Logic 1, high data rate, one subcarrier x2

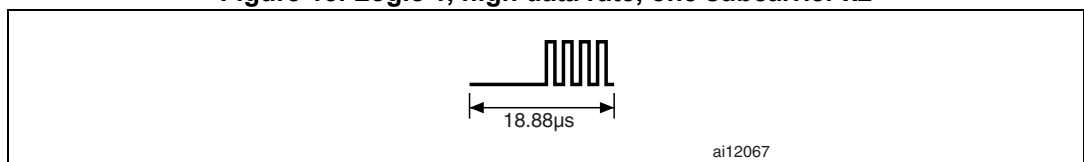

10.1.2 Low data rate

A logic 0 starts with 32 pulses at 423.75 kHz ($f_C/32$) followed by an unmodulated time of 75.52 μs as shown in [Figure 16](#).

Figure 16. Logic 0, low data rate, one subcarrier

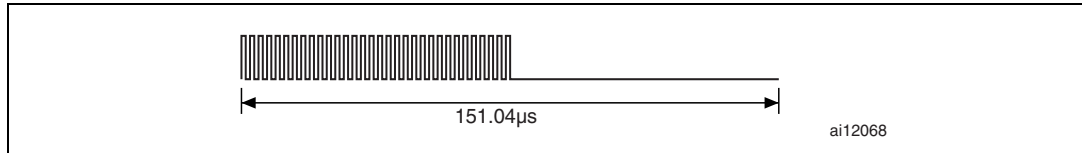

For the Fast commands, a logic 0 starts with 16 pulses at 423.75 kHz ($f_C/32$) followed by an unmodulated time of 37.76 μs as shown in [Figure 17](#).

Figure 17. Logic 0, low data rate, one subcarrier x2

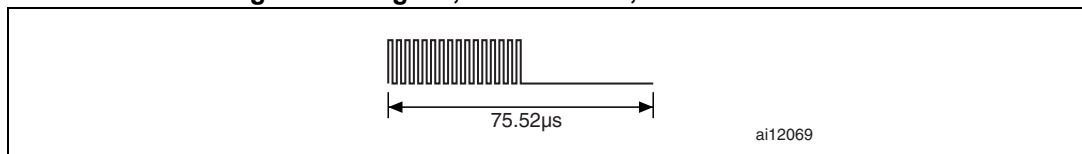

A logic 1 starts with an unmodulated time of 75.52 μs followed by 32 pulses at 423.75 kHz ($f_C/32$) as shown in [Figure 18](#).

Figure 18. Logic 1, low data rate, one subcarrier

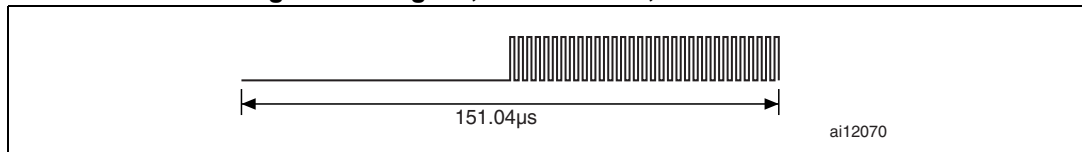

For the Fast commands, a logic 1 starts with an unmodulated time of 37.76 μs followed by 16 pulses at 423.75 kHz ($f_C/32$) as shown in [Figure 18](#).

Figure 19. Logic 1, low data rate, one subcarrier x2

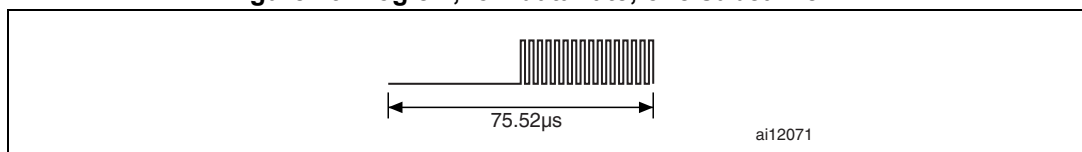

10.2 Bit coding using two subcarriers

10.3 High data rate

A logic 0 starts with eight pulses at 423.75 kHz ($f_C/32$) followed by nine pulses at 484.28 kHz ($f_C/28$), as shown in [Figure 20](#). For the Fast commands, the x2 mode is not available.

Figure 20. Logic 0, high data rate, two subcarriers



A logic 1 starts with nine pulses at 484.28 kHz ($f_C/28$) followed by eight pulses at 423.75 kHz ($f_C/32$) as shown in [Figure 21](#). For the Fast commands, the x2 mode is not available.

Figure 21. Logic 1, high data rate, two subcarriers

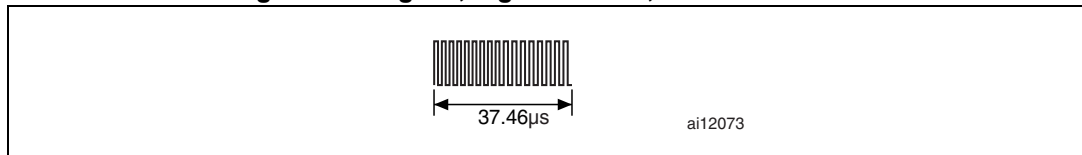

10.4 Low data rate

A logic 0 starts with 32 pulses at 423.75 kHz ($f_C/32$) followed by 36 pulses at 484.28 kHz ($f_C/28$) as shown in [Figure 22](#). For the Fast commands, the x2 mode is not available.

Figure 22. Logic 0, low data rate, two subcarriers

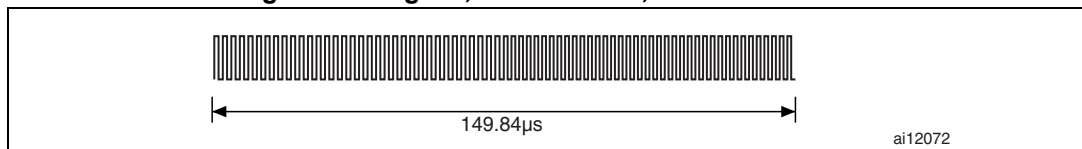

A logic 1 starts with 36 pulses at 484.28 kHz ($f_C/28$) followed by 32 pulses at 423.75 kHz ($f_C/32$) as shown in [Figure 23](#). For the Fast commands, the x2 mode is not available.

Figure 23. Logic 1, low data rate, two subcarriers

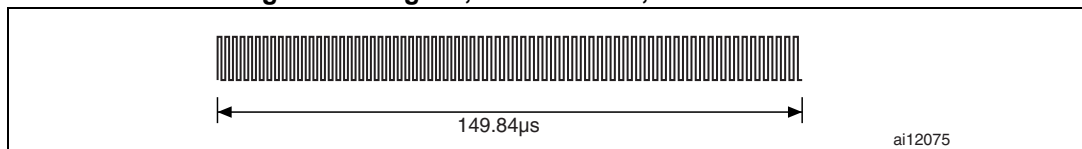

11 ST25TV64K to VCD frames

Frames are delimited by an SOF and an EOF. They are implemented using code violation. Unused options are reserved for future use. For the low data rate, the same subcarrier frequency or frequencies is/are used. In this case the number of pulses is multiplied by 4. For the Fast commands using one subcarrier, all pulse numbers and times are divided by 2.

11.1 SOF when using one subcarrier

11.2 High data rate

The SOF includes an unmodulated time of 56.64 μs , followed by 24 pulses at 423.75 kHz ($f_C/32$), and a logic 1 that consists of an unmodulated time of 18.88 μs followed by eight pulses at 423.75 kHz as shown in [Figure 24](#).

Figure 24. Start of frame, high data rate, one subcarrier

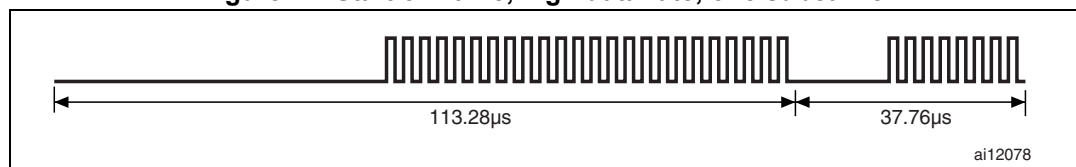

For the Fast commands, the SOF comprises an unmodulated time of 28.32 μs , followed by 12 pulses at 423.75 kHz ($f_C/32$), and a logic 1 that consists of an unmodulated time of 9.44 μs followed by 4 pulses at 423.75 kHz as shown in [Figure 25](#).

Figure 25. Start of frame, high data rate, one subcarrier x2

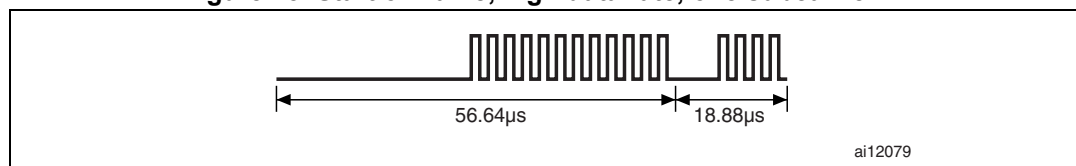

11.3 Low data rate

The SOF comprises an unmodulated time of 226.56 μs , followed by 96 pulses at 423.75 kHz ($f_C/32$), and a logic 1 that consists of an unmodulated time of 75.52 μs followed by 32 pulses at 423.75 kHz as shown in [Figure 26](#).

Figure 26. Start of frame, low data rate, one subcarrier

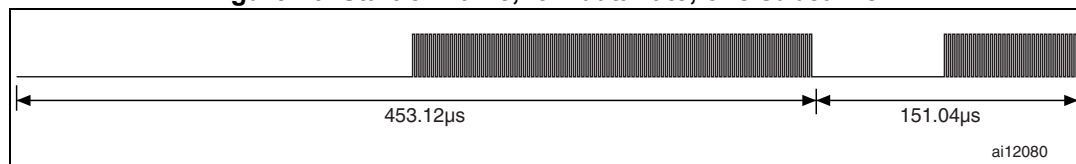

For the Fast commands, the SOF comprises an unmodulated time of 113.28 μs , followed by 48 pulses at 423.75 kHz ($f_C/32$), and a logic 1 that includes an unmodulated time of 37.76

μ s followed by 16 pulses at 423.75 kHz as shown in [Figure 27](#).

Figure 27. Start of frame, low data rate, one subcarrier x2

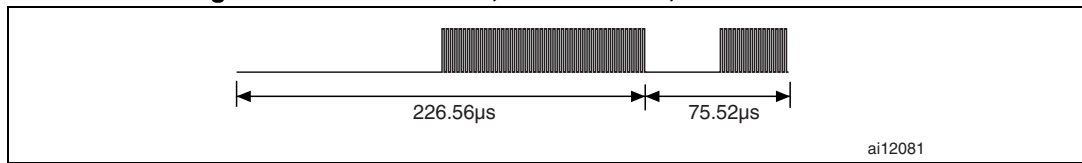

11.4 SOF when using two subcarriers

11.5 High data rate

The SOF comprises 27 pulses at 484.28 kHz ($f_C/28$), followed by 24 pulses at 423.75 kHz ($f_C/32$), and a logic 1 that includes 9 pulses at 484.28 kHz followed by eight pulses at 423.75 kHz as shown in [Figure 28](#).

For the Fast commands, the x2 mode is not available.

Figure 28. Start of frame, high data rate, two subcarriers

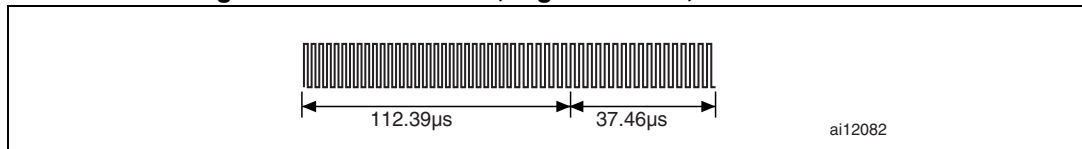

11.6 Low data rate

The SOF comprises 108 pulses at 484.28 kHz ($f_C/28$), followed by 96 pulses at 423.75 kHz ($f_C/32$), and a logic 1 that includes 36 pulses at 484.28 kHz followed by 32 pulses at 423.75 kHz as shown in [Figure 29](#).

For the Fast commands, the x2 mode is not available.

Figure 29. Start of frame, low data rate, two subcarriers

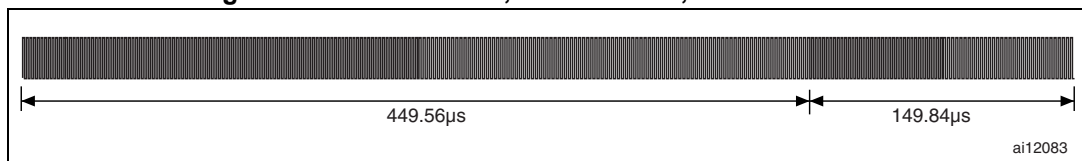

11.7 EOF when using one subcarrier

11.8 High data rate

The EOF comprises a logic 0 that includes eight pulses at 423.75 kHz and an unmodulated time of 18.88 μs , followed by 24 pulses at 423.75 kHz ($f_C/32$), and by an unmodulated time of 56.64 μs as shown in [Figure 30](#).

Figure 30. End of frame, high data rate, one subcarrier

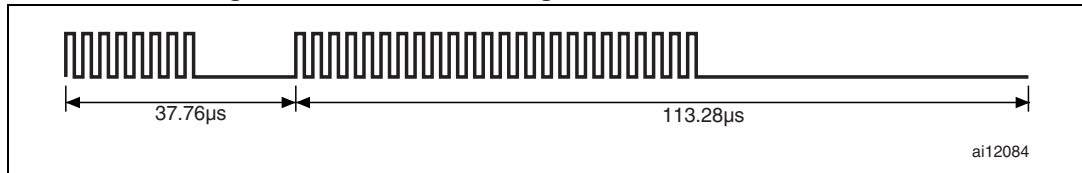

For the Fast commands, the EOF comprises a logic 0 that includes 4 pulses at 423.75 kHz and an unmodulated time of 9.44 μs , followed by 12 pulses at 423.75 kHz ($f_C/32$) and an unmodulated time of 37.76 μs as shown in [Figure 31](#).

Figure 31. End of frame, high data rate, one subcarrier x2

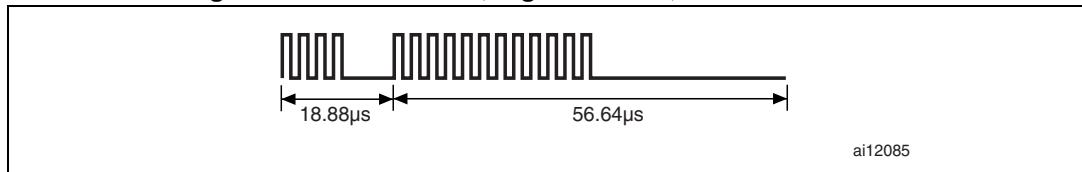

11.9 Low data rate

The EOF comprises a logic 0 that includes 32 pulses at 423.75 kHz and an unmodulated time of 75.52 μs , followed by 96 pulses at 423.75 kHz ($f_C/32$) and an unmodulated time of 226.56 μs as shown in [Figure 32](#).

Figure 32. End of frame, low data rate, one subcarrier

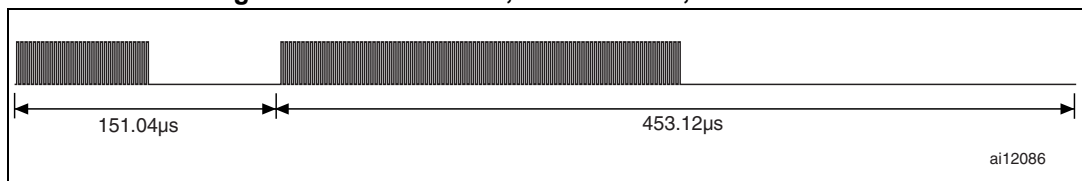

For the Fast commands, the EOF comprises a logic 0 that includes 16 pulses at 423.75 kHz and an unmodulated time of 37.76 μs , followed by 48 pulses at 423.75 kHz ($f_C/32$) and an unmodulated time of 113.28 μs as shown in [Figure 33](#).

Figure 33. End of frame, low data rate, one subcarrier x2

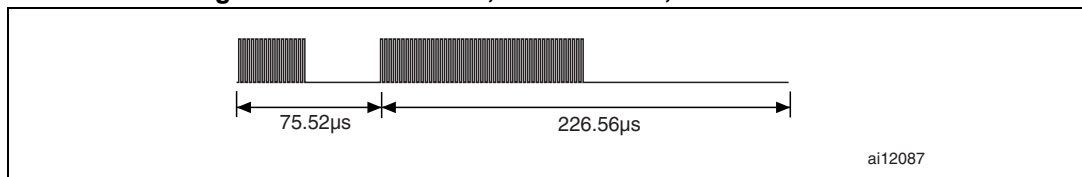

11.10 EOF when using two subcarriers

11.11 High data rate

The EOF comprises a logic 0 that includes eight pulses at 423.75 kHz and 9 pulses at 484.28 kHz, followed by 24 pulses at 423.75 kHz ($f_C/32$) and 27 pulses at 484.28 kHz ($f_C/28$) as shown in [Figure 34](#).

For the Fast commands, the x2 mode is not available.

Figure 34. End of frame, high data rate, two subcarriers

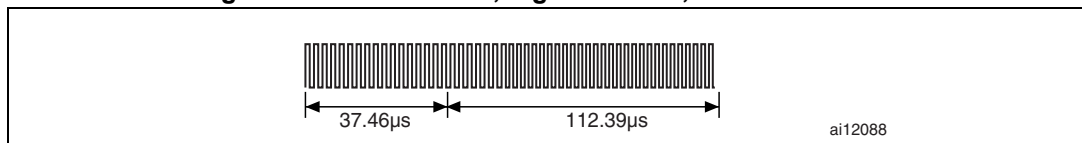

11.12 Low data rate

The EOF comprises a logic 0 that includes 32 pulses at 423.75 kHz and 36 pulses at 484.28 kHz, followed by 96 pulses at 423.75 kHz ($f_C/32$) and 108 pulses at 484.28 kHz ($f_C/28$) as shown in [Figure 35](#).

For the Fast commands, the x2 mode is not available.

Figure 35. End of frame, low data rate, two subcarriers

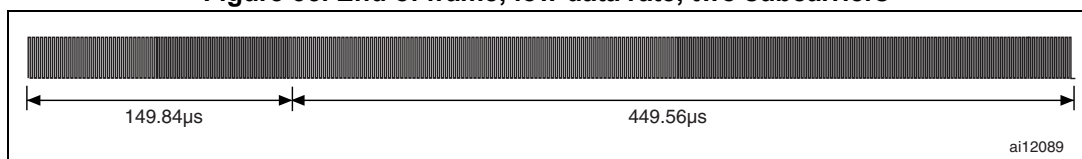

12 Unique identifier (UID)

The ST25TV64K is uniquely identified by a 64-bit Unique Identifier (UID). This UID complies with ISO/IEC 15963 and ISO/IEC 7816-6. The UID is a read-only code and comprises:

- 8 MSBs with a value of E0h
- The IC Manufacturer code of ST 02h, on 8 bits (ISO/IEC 7816-6/AM1)
- a Unique Serial Number on 48 bits

Table 12. UID format

MSB				LSB	
63	56	55	48	47	0
0xE0		0x02		Unique serial number	

With the UID each ST25TV64K can be addressed uniquely and individually during the anticollision loop and for one-to-one exchanges between a VCD and an ST25TV64K.

13 Application family identifier (AFI)

The AFI (application family identifier) represents the type of application targeted by the VCD and is used to identify, among all the ST25TV64Ks present, only the ST25TV64Ks that meet the required application criteria.

Figure 36. ST25TV64K decision tree for AFI

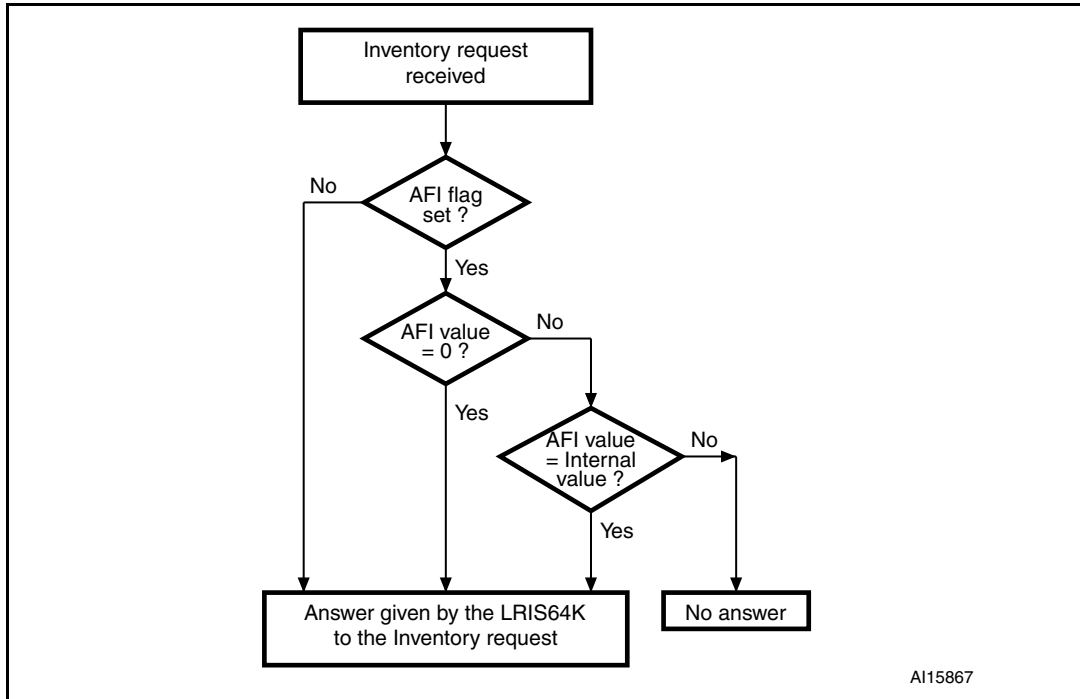

The AFI is programmed by the ST25TV64K issuer (or purchaser) in the AFI register. Once programmed and Locked, it can no longer be modified.

The most significant nibble of the AFI is used to code one specific or all application families.

The least significant nibble of the AFI is used to code one specific or all application subfamilies. Subfamily codes different from 0 are proprietary.

(See ISO/IEC 15693-3 documentation)

14 Data storage format identifier (DSFID)

The data storage format identifier indicates how the data is structured in the ST25TV64K memory. The logical organization of data can be known instantly using the DSFID. It can be programmed and locked using the Write DSFID and Lock DSFID commands.

14.1 CRC

The CRC used in the ST25TV64K is calculated as per the definition in ISO/IEC 13239. The initial register content is all "1"s: "FFFF".

The two-byte CRC are appended to each request and response, within each frame, before the EOF. The CRC is calculated on all the bytes after the SOF up to the CRC field.

Upon reception of a request from the VCD, the ST25TV64K verifies that the CRC value is valid. If it is invalid, the ST25TV64K discards the frame and does not answer to the VCD.

Upon reception of a Response from the ST25TV64K, it is recommended that the VCD verifies whether the CRC value is valid. If it is invalid, actions to be performed are left to the discretion of the VCD designer.

The CRC is transmitted least significant byte first. Each byte is transmitted least significant bit first.

Table 13. CRC transmission rules

LSByte		MSByte	
LSBit	MSBit	LSBit	MSBit
CRC 16 (8 bits)		CRC 16 (8 bits)	

15 ST25TV64K protocol description

The transmission protocol (or simply protocol) defines the mechanism used to exchange instructions and data between the VCD and the ST25TV64K, in both directions. It is based on the concept of “VCD talks first”.

This means that an ST25TV64K will not start transmitting unless it has received and properly decoded an instruction sent by the VCD. The protocol is based on an exchange of:

- a request from the VCD to the ST25TV64K
- a response from the ST25TV64K to the VCD

Each request and each response are contained in a frame. The frame delimiters (SOF, EOF) are described in [Section 11: ST25TV64K to VCD frames](#).

Each request consists of:

- a request SOF (see [Figure 9](#) and [Figure 10](#))
- flags
- a command code
- parameters, depending on the command
- application data
- a 2-byte CRC
- a request EOF (see [Figure 11](#))

Each response consists of:

- an answer SOF (see [Figure 24](#) to [Figure 29](#))
- flags
- parameters, depending on the command
- application data
- a 2-byte CRC
- an answer EOF (see [Figure 30](#) to [Figure 35](#))

The protocol is bit-oriented. The number of bits transmitted in a frame is a multiple of eight (8), that is an integer number of bytes.

A single-byte field is transmitted least significant bit (LSBit) first. A multiple-byte field is transmitted least significant byte (LSByte) first, each byte is transmitted least significant bit (LSBit) first.

The setting of the flags indicates the presence of the optional fields. When the flag is set (to one), the field is present. When the flag is reset (to zero), the field is absent.

Table 14. VCD request frame format

Request SOF	Request_flags	Command code	Parameters	Data	2-byte CRC	Request EOF
-------------	---------------	--------------	------------	------	------------	-------------

Table 15. ST25TV64K Response frame format

Response SOF	Response_flags	Parameters	Data	2-byte CRC	Response EOF
--------------	----------------	------------	------	------------	--------------

Figure 37. ST25TV64K protocol timing

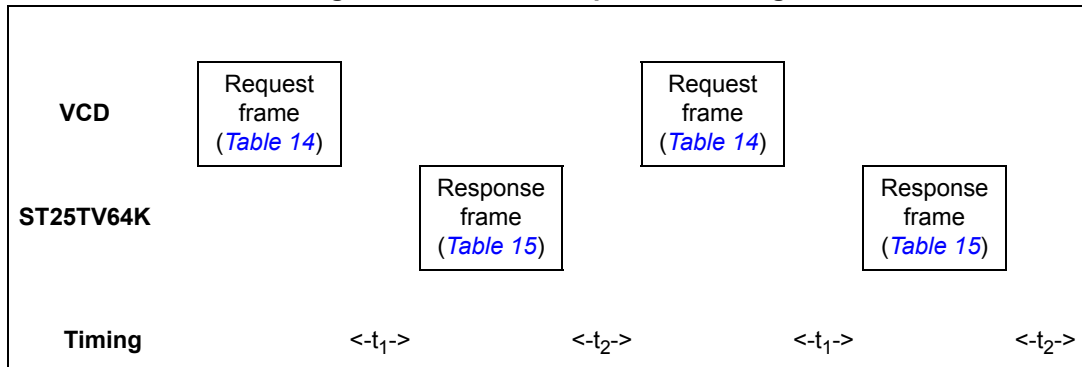

16 ST25TV64K states

An ST25TV64K can be in one of four states:

- Power-off
- Ready
- Quiet
- Selected

Transitions between these states are specified in [Figure 38](#) and [Table 16](#).

16.1 Power-off state

The ST25TV64K is in the Power-off state when it does not receive enough energy from the VCD.

16.2 Ready state

The ST25TV64K is in the Ready state when it receives enough energy from the VCD. When in the Ready state, the ST25TV64K answers any request where the Select_flag is not set.

16.3 Quiet state

When in the Quiet state, the ST25TV64K answers any request except for Inventory requests with the Address_flag set.

16.4 Selected state

In the Selected state, the ST25TV64K answers any request in all modes (see [Section 17: Modes](#)):

- Request in Select mode with the Select_flag set
- Request in Addressed mode if the UID matches
- Request in Non-Addressed mode as it is the mode for general requests

Table 16. ST25TV64K response depending on Request_flags

Flags	Address_flag		Select_flag	
	1 Addressed	0 Non addressed	1 Selected	0 Non selected
ST25TV64K in Ready or Selected state (Devices in Quiet state do not answer)	-	X	-	X
ST25TV64K in Selected state	-	X	X	-
ST25TV64K in Ready, Quiet or Selected state (the device that matches the UID)	X	-	-	X
Error (03h)	X	-	X	-

Figure 38. ST25TV64K state transition diagram

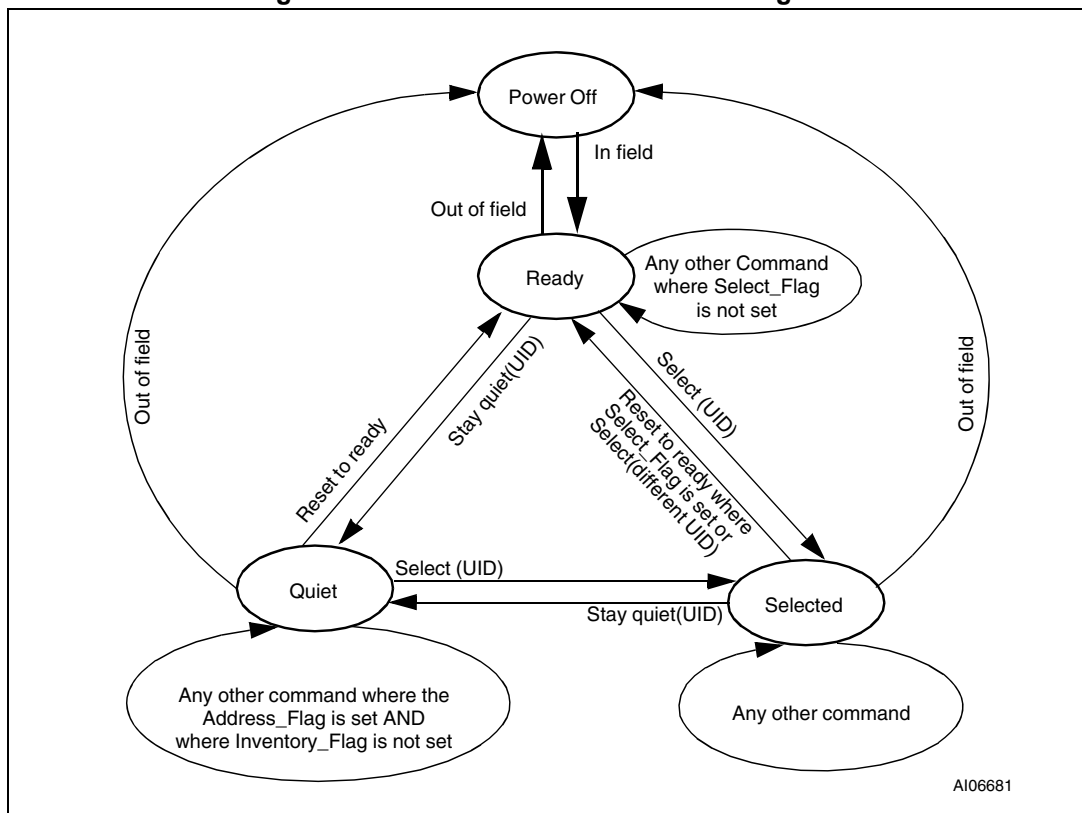

1. The intention of the state transition method is that only one ST25TV64K should be in the selected state at any time.

17 Modes

The term “mode” refers to the mechanism used in a request to specify the set of ST25TV64Ks that will answer the request.

17.1 Addressed mode

When the `Address_flag` is set to 1 (Addressed mode), the request contains the Unique ID (UID) of the addressed ST25TV64K.

Any ST25TV64K that receives a request with the `Address_flag` set to 1 compares the received Unique ID to its own. If it matches, then the ST25TV64K executes the request (if possible) and returns a response to the VCD as specified in the command description.

If the UID does not match, then it remains silent.

17.2 Non-addressed mode (general request)

When the `Address_flag` is cleared to 0 (Non-Addressed mode), the request does not contain a Unique ID. Any ST25TV64K receiving a request with the `Address_flag` cleared to 0 executes it and returns a response to the VCD as specified in the command description.

17.3 Select mode

When the `Select_flag` is set to 1 (Select mode), the request does not contain an ST25TV64K Unique ID. The ST25TV64K in the Selected state that receives a request with the `Select_flag` set to 1 executes it and returns a response to the VCD as specified in the command description.

Only ST25TV64Ks in the Selected state answer a request where the `Select_flag` set to 1.

The system design ensures in theory that only one ST25TV64K can be in the Select state at a time.

18 Request format

The request consists of:

- an SOF
- flags
- a command code
- parameters and data
- a CRC
- an EOF

Table 17. General request format

S O F	Request_flags	Command code	Parameters	Data	CRC	E O F
-------------	---------------	--------------	------------	------	-----	-------------

18.1 Request flags

In a request, the “flags” field specifies the actions to be performed by the ST25TV64K and whether corresponding fields are present or not.

The flags field consists of eight bits. The bit 3 (Inventory_flag) of the request flag defines the contents of the 4 MSBs (bits 5 to 8). When bit 3 is reset (0), bits 5 to 8 define the ST25TV64K selection criteria. When bit 3 is set (1), bits 5 to 8 define the ST25TV64K Inventory parameters.

Table 18. Definition of request flags 1 to 4

Bit No.	Flag	Level	Description
Bit 1	Subcarrier_flag ⁽¹⁾	0	A single subcarrier frequency is used by the ST25TV64K
		1	Two subcarriers are used by the ST25TV64K
Bit 2	Data_rate_flag ⁽²⁾	0	Low data rate is used
		1	High data rate is used
Bit 3	Inventory_flag	0	The meaning of flags 5 to 8 is described in Table 19
		1	The meaning of flags 5 to 8 is described in Table 20
Bit 4	Protocol_extension_flag	0	No Protocol format extension
		1	Protocol format extension

1. Subcarrier_flag refers to the ST25TV64K-to-VCD communication.

2. Data_rate_flag refers to the ST25TV64K-to-VCD communication

Table 19. Request flags 5 to 8 when Bit 3 = 0

Bit No.	Flag	Level	Description
Bit 5	Select flag ⁽¹⁾	0	Request is executed by any ST25TV64K according to the setting of Address_flag
		1	Request is executed only by the ST25TV64K in Selected state
Bit 6	Address flag ⁽¹⁾	0	Request is not addressed. UID field is not present. The request is executed by all ST25TV64Ks.
		1	Request is addressed. UID field is present. The request is executed only by the ST25TV64K whose UID matches the UID specified in the request.
Bit 7	Option flag	0	Option not activated.
		1	Option activated.
Bit 8	RFU	0	-

1. If the Select_flag is set to 1, the Address_flag is set to 0 and the UID field is not present in the request.

Table 20. Request flags 5 to 8 when Bit 3 = 1

Bit No.	Flag	Level	Description
Bit 5	AFI flag	0	AFI field is not present
		1	AFI field is present
Bit 6	Nb_slots flag	0	16 slots
		1	1 slot
Bit 7	Option flag	0	-
Bit 8	RFU	0	-

19 Response format

The response consists of:

- an SOF
- flags
- parameters and data
- a CRC
- an EOF

Table 21. General response format

S O F	Response_flags	Parameters	Data	CRC	E O F
-------------	----------------	------------	------	-----	-------------

19.1 Response flags

In a response, the flags indicate how actions have been performed by the ST25TV64K and whether corresponding fields are present or not. The response flags consist of eight bits.

Table 22. Definitions of response flags 1 to 8

Bit No	Flag	Level	Description
Bit 1	Error_flag	0	No error
		1	Error detected. Error code is in the "Error" field.
Bit 2	RFU	0	-
Bit 3	RFU	0	-
Bit 4	Extension flag	0	No extension
Bit 5	RFU	0	-
Bit 6	RFU	0	-
Bit 7	RFU	0	-
Bit 8	RFU	0	-

19.2 Response error code

If the Error_flag is set by the ST25TV64K in the response, the Error code field is present and provides information about the error that occurred.

Error codes not specified in [Table 23](#) are reserved for future use.

Table 23. Response error code definition

Error code	Meaning
02h	The command is not recognized, for example a format error occurred
03h	The option is not supported
0Fh	Error with no information given
10h	The specified block is not available
11h	The specified block is already locked and thus cannot be locked again
12h	The specified block is locked and its contents cannot be changed.
13h	The specified block was not successfully programmed
14h	The specified block was not successfully locked
15h	The specified block is read-protected

20 Anticollision

The purpose of the anticollision sequence is to inventory the ST25TV64Ks present in the VCD field using their unique ID (UID).

The VCD is the master of communications with one or several ST25TV64Ks. It initiates ST25TV64K communication by issuing the Inventory request.

The ST25TV64K sends its response in the determined slot or does not respond.

20.1 Request parameters

When issuing the Inventory Command, the VCD:

- sets the Nb_slots_flag as desired
- adds the mask length and the mask value after the command field
- The mask length is the number of significant bits of the mask value.
- The mask value is contained in an integer number of bytes. The mask length indicates the number of significant bits. LSB is transmitted first
- If the mask length is not a multiple of 8 (bits), as many 0-bits as required will be added to the mask value MSB so that the mask value is contained in an integer number of bytes
- The next field starts at the next byte boundary.

Table 24. Inventory request format

MSB SOF	Request _flags	Command	Optional AF _I (¹)	Mask length	Mask value	CRC	LSB EOF
-	8 bits	8 bits	8 bits	8 bits	0 to 8 bytes	16 bits	-

1. Gray means that the field is optional.

In the example of the [Table 25](#) and [Figure 39](#), the mask length is 11 bits. Five 0-bits are added to the mask value MSB. The 11-bit Mask and the current slot number are compared to the UID.

Table 25. Example of the addition of 0-bits to an 11-bit mask value

(b ₁₅) MSB	LSB (b ₀)
0000 0	100 1100 1111
0-bits added	11-bit mask value

Figure 39. Principle of comparison between the mask, the slot number and the UID

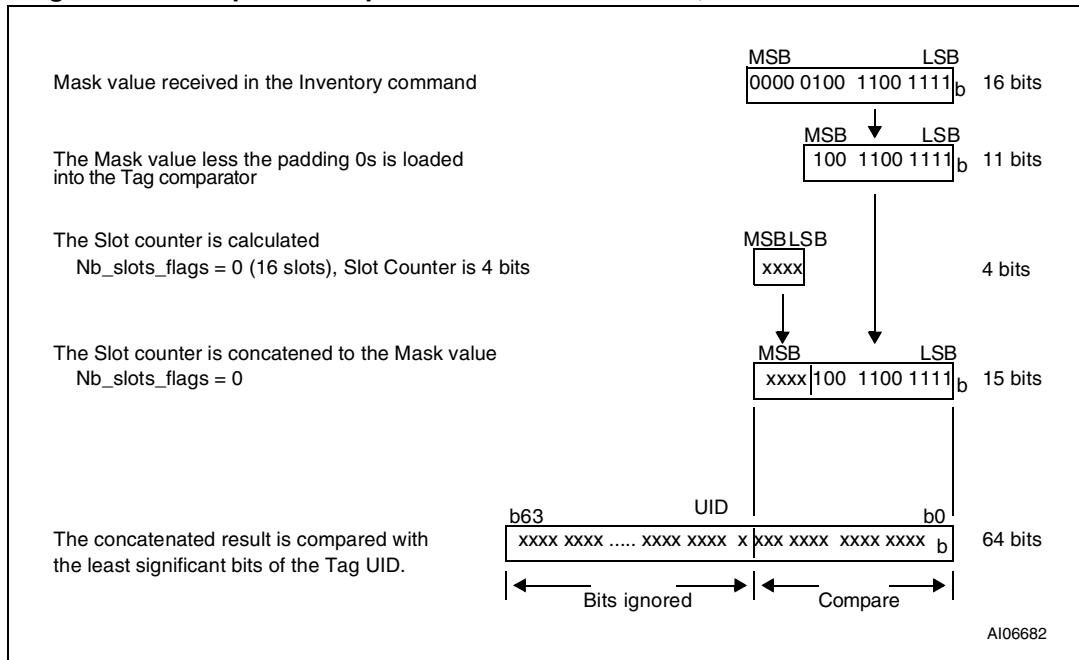

The AFI field is present if the AFI_flag is set.

The pulse is generated according to the definition of the EOF in ISO/IEC 15693-2.

The first slot starts immediately after the reception of the request EOF. To switch to the next slot, the VCD sends an EOF.

The following rules and restrictions apply:

- if no ST25TV64K answer is detected, the VCD may switch to the next slot by sending an EOF
- if one or more ST25TV64K answers are detected, the VCD waits until the complete frame has been received before sending an EOF for switching to the next slot.

21 Request processing by the ST25TV64K

Upon reception of a valid request, the ST25TV64K performs the following algorithm:

- NbS is the total number of slots (1 or 16)
- SN is the current slot number (0 to 15)
- LSB (value, n) function returns the n Less Significant Bits of value
- MSB (value, n) function returns the n Most Significant Bits of value
- “&” is the concatenation operator
- Slot_Frame is either an SOF or an EOF

```
SN = 0
if (Nb_slots_flag)
  then NbS = 1
       SN_length = 0
       endif
  else NbS = 16
       SN_length = 4
       endif

label1:
if LSB (UID, SN_length + Mask_length) =
  LSB (SN, SN_length) & LSB (Mask, Mask_length)
  then answer to inventory request
  endif

wait (Slot_Frame)

if Slot_Frame = SOF
  then Stop Anticollision
       decode/process request
       exit
  endif

if Slot_Frame = EOF
  if SN < NbS-1
    then SN = SN + 1
         goto label1
         exit
    endif
  endif
```

22 Explanation of the possible cases

Figure 40 summarizes the main possible cases that can occur during an anticollision sequence when the slot number is 16.

The different steps are:

- The VCD sends an Inventory request, in a frame terminated by an EOF. The number of slots is 16.
- ST25TV64K_1 transmits its response in Slot 0. It is the only one to do so, therefore no collision occurs and its UID is received and registered by the VCD.
- The VCD sends an EOF in order to switch to the next slot.
- In Slot 1, two ST25TV64Ks, ST25TV64K_2 and ST25TV64K_3 transmit a response, thus generating a collision. The VCD records the event and remembers that a collision was detected in Slot 1.
- The VCD sends an EOF in order to switch to the next slot.
- In Slot 2, no ST25TV64K transmits a response. Therefore the VCD does not detect any ST25TV64K SOF and decides to switch to the next slot by sending an EOF.
- In Slot 3, there is another collision caused by responses from ST25TV64K_4 and ST25TV64K_5.
- The VCD then decides to send a request (for instance a Read Block) to ST25TV64K_1, whose UID has already been correctly received.
- All ST25TV64Ks detect an SOF and exit the anticollision sequence. They process this request, and since the request is addressed to ST25TV64K_1, only ST25TV64K_1 transmits a response.
- All ST25TV64Ks are ready to receive another request. If it is an Inventory command, the slot numbering sequence restarts from 0.

Note: The decision to interrupt the anticollision sequence is made by the VCD. It could have continued to send EOFs until Slot 16 and only then sent the request to ST25TV64K_1.

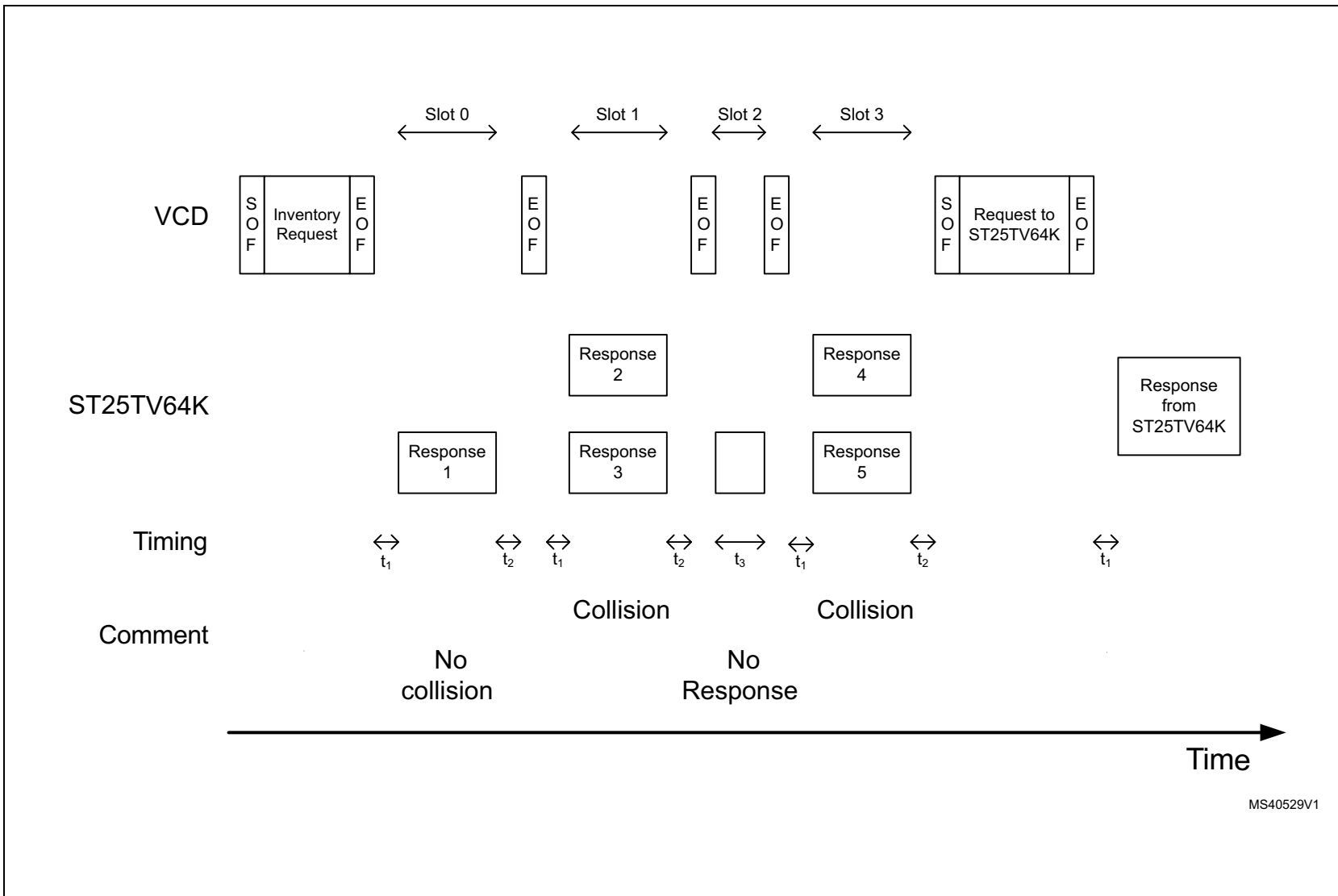
Figure 40. Description of a possible anticollision sequence

23 Inventory Initiated command

The ST25TV64K provides a special feature to improve the inventory time response of moving tags using the `Initiate_flag` value. This flag, controlled by the `Initiate` command, allows tags to answer to `Inventory Initiated` commands.

For applications in which multiple tags are moving in front of a reader, it is possible to miss tags using the standard inventory command. The reason is that the inventory sequence has to be performed on a global tree search. For example, a tag with a particular UID value may have to wait the run of a long tree search before being inventoried. If the delay is too long, the tag may be out of the field before it has been detected.

Using the `Initiate` command, the inventory sequence is optimized. When multiple tags are moving in front of a reader, the ones which are within the reader field will be initiated by the `Initiate` command. In this case, a small batch of tags will answer to the `Inventory Initiated` command which will optimize the time necessary to identify all the tags. When finished, the reader has to issue a new `Initiate` command in order to initiate a new small batch of tags which are new inside the reader field.

It is also possible to reduce the inventory sequence time using the `Fast Initiate` and `Fast Inventory Initiated` commands. These commands allow the ST25TV64Ks to increase their response data rate by a factor of 2, up to 53 Kbit/s.

24 Timing definition

24.1 t_1 : ST25TV64K response delay

Upon detection of the rising edge of the EOF received from the VCD, the ST25TV64K waits for a time t_{1nom} before transmitting its response to a VCD request or before switching to the next slot during an inventory process. Values of t_1 are given in [Table 26](#). The EOF is defined in [Figure 11 on page 27](#).

24.2 t_2 : VCD new request delay

t_2 is the time after which the VCD may send an EOF to switch to the next slot when one or more ST25TV64K responses have been received during an Inventory command. It starts from the reception of the EOF from the ST25TV64Ks.

The EOF sent by the VCD may be either 10% or 100% modulated regardless of the modulation index used for transmitting the VCD request to the ST25TV64K.

t_2 is also the time after which the VCD may send a new request to the ST25TV64K as described in [Table 37: ST25TV64K protocol timing](#).

Values of t_2 are given in [Table 26](#).

24.3 t_3 : VCD new request delay in the absence of a response from the ST25TV64K

t_3 is the time after which the VCD may send an EOF to switch to the next slot when no ST25TV64K response has been received.

The EOF sent by the VCD may be either 10% or 100% modulated regardless of the modulation index used for transmitting the VCD request to the ST25TV64K.

From the time the VCD has generated the rising edge of an EOF:

- If this EOF is 100% modulated, the VCD waits a time at least equal to t_{3min} before sending a new EOF.
- If this EOF is 10% modulated, the VCD waits a time at least equal to the sum of t_{3min} + the ST25TV64K nominal response time (which depends on the ST25TV64K data rate and subcarrier modulation mode) before sending a new EOF.

Table 26. Timing values⁽¹⁾

	Minimum (min) values	Nominal (nom) values	Maximum (max) values
t_1	318.6 μ s	320.9 μ s	323.3 μ s
t_2	309.2 μ s	No t_{nom}	No t_{max}
t_3	$t_{1max}^{(2)} + t_{SOF}^{(3)}$	No t_{nom}	No t_{max}

1. The tolerance of specific timings is $\pm 32/f_C$.

2. t_{1max} does not apply for write alike requests. Timing conditions for write alike requests are defined in the command description.

3. t_{SOF} is the time taken by the ST25TV64K to transmit an SOF to the VCD. t_{SOF} depends on the current data rate: High data rate or Low data rate.

25 Commands codes

The ST25TV64K supports the commands described in this section, their codes are listed in [Table 27](#).

Table 27. Command codes

Command code standard	Function	Command code custom	Function
01h	Inventory	2Ch	Get Multiple Block Security Status
02h	Stay Quiet	B1h	Write-sector Password
20h	Read Single Block	B2h	Lock-Sector
21h	Write Single Block	B3h	Present-sector Password
23h	Read Multiple Block	C0h	Fast Read Single Block
25h	Select	C1h	Fast Inventory Initiated
26h	Reset to Ready	C2h	Fast Initiate
27h	Write AFI	C3h	Fast Read Multiple Block
28h	Lock AFI	D1h	Inventory Initiated
29h	Write DSFID	D2h	Initiate
2Ah	Lock DSFID		
2Bh	Get System Info		

25.1 Inventory

When receiving the Inventory request, the ST25TV64K runs the anticollision sequence. The Inventory_flag is set to 1. The meaning of flags 5 to 8 is shown in [Table 20: Request flags 5 to 8 when Bit 3 = 1](#).

The request contains:

- the flags,
- the Inventory command code (see [Table 27: Command codes](#))
- the AFI if the AFI flag is set
- the mask length
- the mask value
- the CRC

The ST25TV64K does not generate any answer in case of error.

Table 28. Inventory request format

Request SOF	Request_flags	Inventory	Optional AFI ⁽¹⁾	Mask length	Mask value	CRC16	Request EOF
-	8 bits	01h	8 bits	8 bits	0 - 64 bits	16 bits	-

1. Gray means that the field is optional.

The response contains:

- the flags
- the Unique ID

Table 29. Inventory response format

Response SOF	Response_flags	DSFID	UID	CRC16	Response EOF
-	8 bits	8 bits	64 bits	16 bits	-

During an Inventory process, if the VCD does not receive an RF ST25TV64K response, it waits a time t_3 before sending an EOF to switch to the next slot. t_3 starts from the rising edge of the request EOF sent by the VCD.

- If the VCD sends a 100% modulated EOF, the minimum value of t_3 is:
 $t_{3min} = 4384/f_C (323.3\mu s) + t_{SOF}$
- If the VCD sends a 10% modulated EOF, the minimum value of t_3 is:
 $t_{3min} = 4384/f_C (323.3\mu s) + t_{NRT}$

where:

- t_{SOF} is the time required by the ST25TV64K to transmit an SOF to the VCD
- t_{NRT} is the nominal response time of the ST25TV64K

t_{NRT} and t_{SOF} are dependent on the ST25TV64K-to-VCD data rate and subcarrier modulation mode.

25.2 Stay Quiet

Command code = 0x02

On receiving the Stay Quiet command, the ST25TV64K enters the Quiet State if no error occurs, and does NOT send back a response. There is NO response to the Stay Quiet command even if an error occurs.

When in the Quiet state:

- the ST25TV64K does not process any request if the Inventory_flag is set,
- the ST25TV64K processes any Addressed request

The ST25TV64K exits the Quiet State when:

- it is reset (power off),
- receiving a Select request. It then goes to the Selected state,
- receiving a Reset to Ready request. It then goes to the Ready state.

Table 30. Stay Quiet request format

Request SOF	Request flags	Stay Quiet	UID	CRC16	Request EOF
-	8 bits	02h	64 bits	16 bits	-

The Stay Quiet command must always be executed in Addressed mode (Select_flag is reset to 0 and Address_flag is set to 1).

Figure 41. Stay Quiet frame exchange between VCD and ST25TV64K

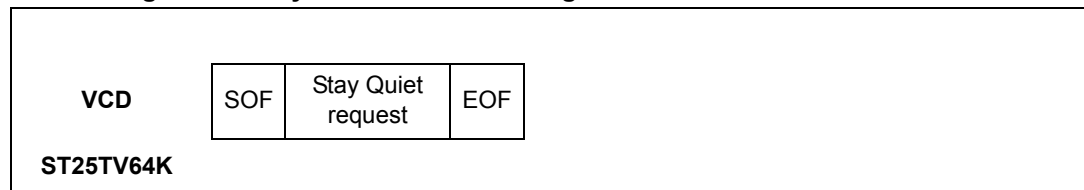

25.3 Read Single Block

On receiving the Read Single Block command, the ST25TV64K reads the requested block and sends back its 32-bit value in the response. The Protocol_extention_flag should be set to 1 for the ST25TV64K to operate correctly. If the Protocol_extention_flag is at 0, the ST25TV64K answers with an error code. The Option_flag is supported.

Table 31. Read Single Block request format

Request SOF	Request_flags	Read Single Block	UID ⁽¹⁾	Block number	CRC16	Request EOF
-	8 bits	20h	64 bits	16 bits	16 bits	-

1. Gray means that the field is optional.

Request parameters:

- Option_flag
- UID (optional)
- Block number

Table 32. Read Single Block response format when Error_flag is NOT set

Response SOF	Response_flags	Sector security status ⁽¹⁾	Data	CRC16	Response EOF
-	8 bits	8 bits	32 bits	16 bits	-

1. Gray means that the field is optional.

Response parameters:

- Sector security status if Option_flag is set (see [Table 33](#))
- 4 bytes of block data

Table 33. Sector security status

b ₇	b ₆	b ₅	b ₄	b ₃	b ₂	b ₁	b ₀
Reserved for future use. All at 0			password control bits		Read / Write protection bits		0: Current sector not locked 1: Current sector locked

Table 34. Read Single Block response format when Error_flag is set

Response SOF	Response_flags	Error code	CRC16	Response EOF
-	8 bits	8 bits	16 bits	-

Response parameter:

- Error code as Error_flag is set
 - 10h: the specified block is not available
 - 15h: the specified block is read-protected

Figure 42. Read Single Block frame exchange between VCD and ST25TV64K

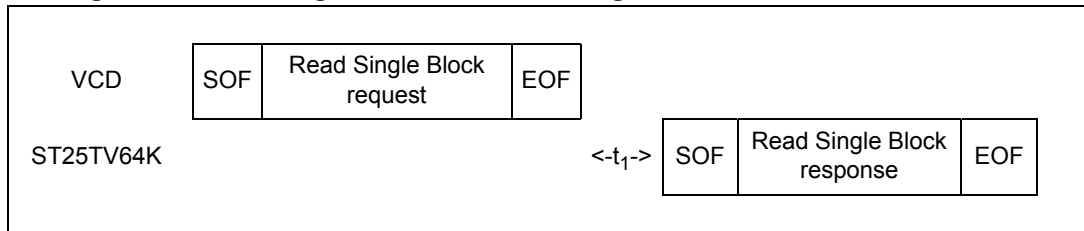

25.4 Write Single Block

On receiving the Write Single Block command, the ST25TV64K writes the data contained in the request to the requested block and reports whether the write operation was successful in the response. The Protocol_extention_flag should be set to 1 for the ST25TV64K to operate correctly. If the Protocol_extention_flag is at 0, the ST25TV64K answers with an error code. The Option_flag is supported.

During write cycle W_t , there should be no modulation (neither 100% nor 10%). Otherwise, the ST25TV64K may not program correctly the data into the memory. The W_t time is equal to $t_{1nom} + 18 \times 302 \mu s$.

Table 35. Write Single Block request format

Request SOF	Request_flags	Write Single Block	UID ⁽¹⁾	Block number	Data	CRC16	Request EOF
-	8 bits	21h	64 bits	16 bits	32 bits	16 bits	-

1. Gray means that the field is optional.

Request parameters:

- Request flags
- UID (optional)
- Block number
- Data

Table 36. Write Single Block response format when Error_flag is NOT set

Response SOF	Response_flags	CRC16	Response EOF
-	8 bits	16 bits	-

Response parameter:

- No parameter. The response is send back after the writing cycle.

Table 37. Write Single Block response format when Error_flag is set

Response SOF	Response_flags	Error code	CRC16	Response EOF
-	8 bits	8 bits	16 bits	-

Response parameter:

- Error code as Error_flag is set:
 - 0Fh: error with no information given
 - 10h: the specified block is not available
 - 12h: the specified block is locked and its contents cannot be changed.
 - 13h: the specified block was not successfully programmed

Figure 43. Write Single Block frame exchange between VCD and ST25TV64K

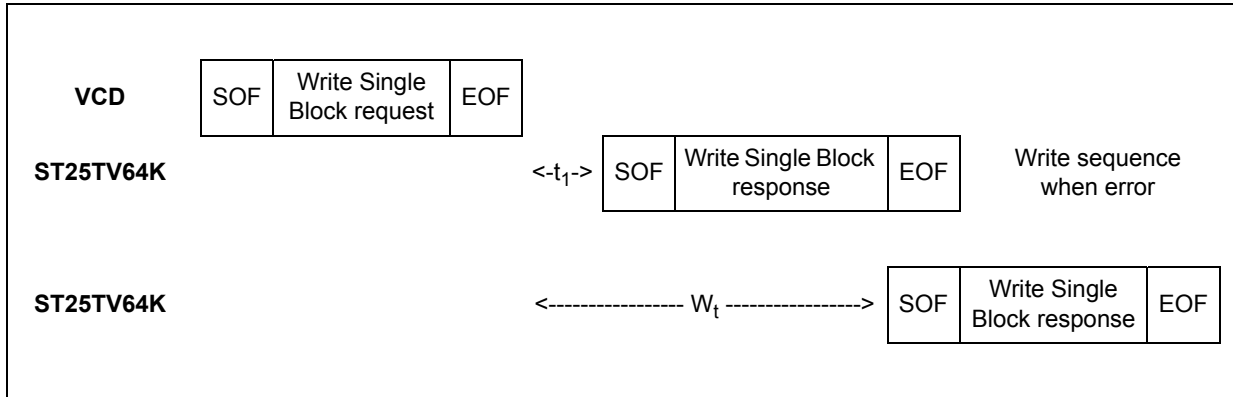

25.5 Read Multiple Block

When receiving the Read Multiple Block command, the ST25TV64K reads the selected blocks and sends back their value in multiples of 32 bits in the response. The blocks are numbered from '00h to '7FFh' in the request and the value is minus one (-1) in the field. For example, if the “number of blocks” field contains the value 06h, 7 blocks are read. The maximum number of blocks is fixed at 32 assuming that they are all located in the same sector. If the number of blocks overlaps sectors, the ST25TV64K returns an error code. The Protocol_extention_flag should be set to 1 for the ST25TV64K to operate correctly. If the Protocol_extention_flag is at 0, the ST25TV64K answers with an error code. The Option_flag is supported.

Table 38. Read Multiple Block request format

Request SOF	Request flags	Read Multiple Block	UID ⁽¹⁾	First block number	Number of blocks	CRC16	Request EOF
-	8 bits	23h	64 bits	16 bits	8 bits	16 bits	-

1. Gray means that the field is optional.

Request parameters:

- Request flags
- UID (optional)
- First block number
- Number of blocks

Table 39. Read Multiple Block response format when Error_flag is NOT set

Response SOF	Response flags	Sector security status ⁽¹⁾	Data	CRC16	Response EOF
-	8 bits	8 bits ⁽²⁾	32 bits ⁽²⁾	16 bits	-

1. Gray means that the field is optional.

2. Repeated as needed.

Response parameters:

- Sector security status if Option_flag is set (see [Table 40](#))
- N blocks of data

Table 40. Sector security status

b ₇	b ₆	b ₅	b ₄	b ₃	b ₂	b ₁	b ₀
Reserved for future use. All at 0			password control bits		Read / Write protection bits		0: Current sector not locked 1: Current sector locked

Table 41. Read Multiple Block response format when Error_flag is set

Response SOF	Response_flags	Error code	CRC16	Response EOF
-	8 bits	8 bits	16 bits	-

Response parameter:

- Error code as Error_flag is set:
 - 0Fh: error with no information given
 - 10h: the specified block is not available
 - 15h: the specified block is read-protected

Figure 44. Read Multiple Block frame exchange between VCD and ST25TV64K

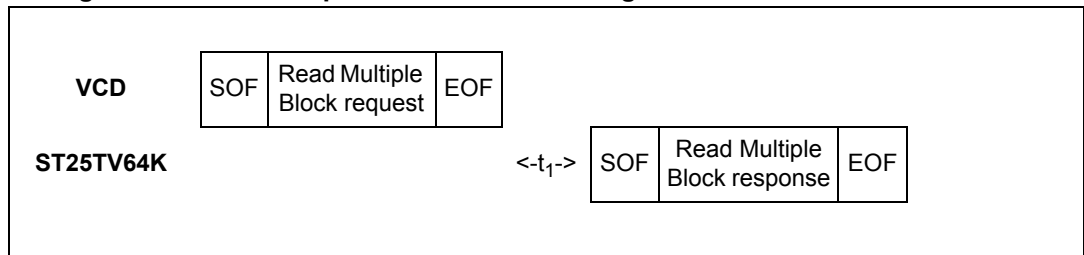

25.6 Select

When receiving the Select command:

- if the UID is equal to its own UID, the ST25TV64K enters or stays in the Selected state and sends a response.
- if the UID does not match its own, the selected ST25TV64K returns to the Ready state and does not send a response.

The ST25TV64K answers an error code only if the UID is equal to its own UID. If not, no response is generated. If an error occurs, the ST25TV64K remains in its current state.

Table 42. Select request format

Request SOF	Request_flags	Select	UID	CRC16	Request EOF
-	8 bits	25h	64 bits	16 bits	-

Request parameter:

- UID

Table 43. Select Block response format when Error_flag is NOT set

Response SOF	Response_flags	CRC16	Response EOF
-	8 bits	16 bits	-

Response parameter:

- No parameter.

Table 44. Select response format when Error_flag is set

Response SOF	Response_flags	Error code	CRC16	Response EOF
-	8 bits	8 bits	16 bits	-

Response parameter:

- Error code as Error_flag is set:
 - 03h: the option is not supported

Figure 45. Select frame exchange between VCD and ST25TV64K

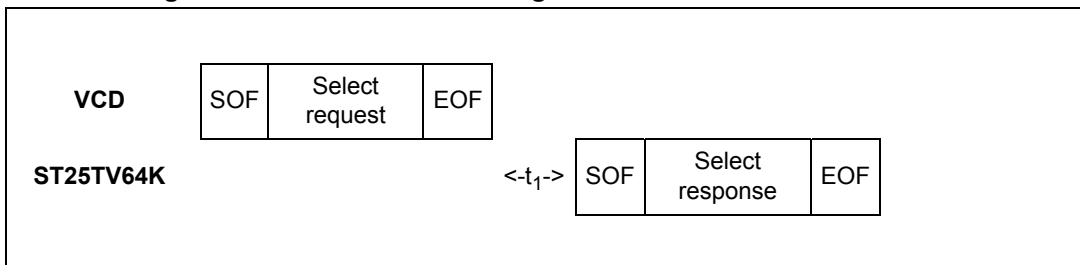

25.7 Reset to Ready

On receiving a Reset to Ready command, the ST25TV64K returns to the Ready state if no error occurs. In the Addressed mode, the ST25TV64K answers an error code only if the UID is equal to its own UID. If not, no response is generated.

Table 45. Reset to Ready request format

Request SOF	Request flags	Reset to Ready	UID ⁽¹⁾	CRC16	Request EOF
-	8 bits	26h	64 bits	16 bits	-

1. Gray means that the field is optional.

Request parameter:

- UID (optional)

Table 46. Reset to Ready response format when Error_flag is NOT set

Response SOF	Response flags	CRC16	Response EOF
-	8 bits	16 bits	-

Response parameter:

- No parameter

Table 47. Reset to ready response format when Error_flag is set

Response SOF	Response flags	Error code	CRC16	Response EOF
-	8 bits	8 bits	16 bits	-

Response parameter:

- Error code as Error_flag is set:
 - 03h: the option is not supported

Figure 46. Reset to Ready frame exchange between VCD and ST25TV64K

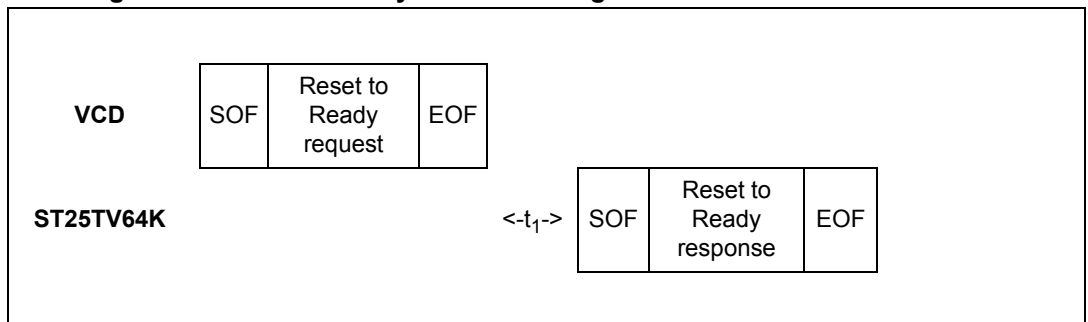

25.8 Write AFI

On receiving the Write AFI request, the ST25TV64K programs the 8-bit AFI value to its memory. The Option_flag is supported.

During write cycle W_t , there should be no modulation (neither 100% nor 10%). Otherwise, the ST25TV64K may not write correctly the AFI value into the memory. The W_t time is equal to $t_{1nom} + 18 \times 302 \mu s$.

Table 48. Write AFI request format

Request SOF	Request _flags	Write AFI	UID ⁽¹⁾	AFI	CRC16	Request EOF
-	8 bits	27h	64 bits	8 bits	16 bits	-

1. Gray means that the field is optional.

Request parameter:

- Request flags
- UID (optional)
- AFI

Table 49. Write AFI response format when Error_flag is NOT set

Response SOF	Response_flags	CRC16	Response EOF
-	8 bits	16 bits	-

Response parameter:

- No parameter.

Table 50. Write AFI response format when Error_flag is set

Response SOF	Response_flags	Error code	CRC16	Response EOF
-	8 bits	8 bits	16 bits	-

Response parameter:

- Error code as Error_flag is set
 - 12h: the specified block is locked and its contents cannot be changed.
 - 13h: the specified block was not successfully programmed

Figure 47. Write AFI frame exchange between VCD and ST25TV64K

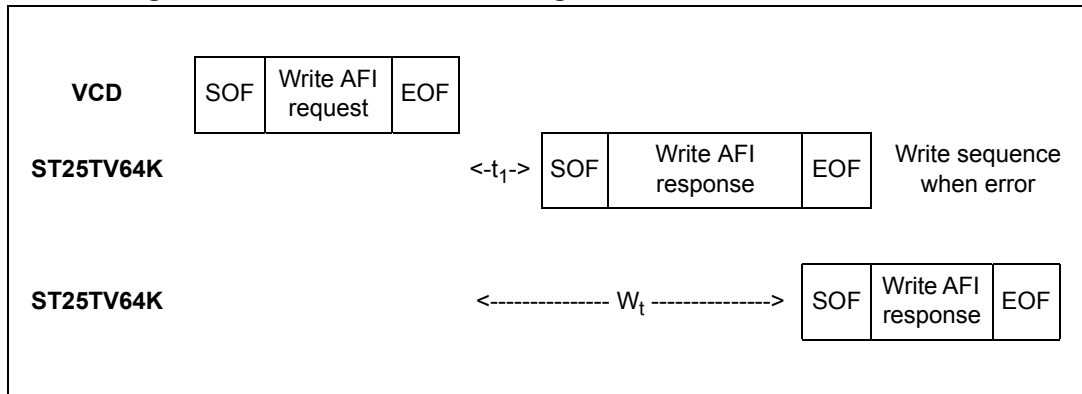

25.9 Lock AFI

On receiving the Lock AFI request, the ST25TV64K locks the AFI value permanently. The Option_flag is supported.

During write cycle W_t , there should be no modulation (neither 100% nor 10%). Otherwise, the ST25TV64K may not Lock correctly the AFI value in memory. The W_t time is equal to $t_{1nom} + 18 \times 302 \mu s$.

Table 51. Lock AFI request format

Request SOF	Request_flags	Lock AFI	UID ⁽¹⁾	CRC16	Request EOF
-	8 bits	28h	64 bits	16 bits	-

1. Gray means that the field is optional.

Request parameter:

- Request flags
- UID (optional)

Table 52. Lock AFI response format when Error_flag is NOT set

Response SOF	Response_flags	CRC16	Response EOF
-	8 bits	16 bits	-

Response parameter:

- No parameter

Table 53. Lock AFI response format when Error_flag is set

Response SOF	Response_flags	Error code	CRC16	Response EOF
-	8 bits	8 bits	16 bits	-

Response parameter:

- Error code as Error_flag is set
 - 11h: the specified block is already locked and thus cannot be locked again
 - 14h: the specified block was not successfully locked

Figure 48. Lock AFI frame exchange between VCD and ST25TV64K

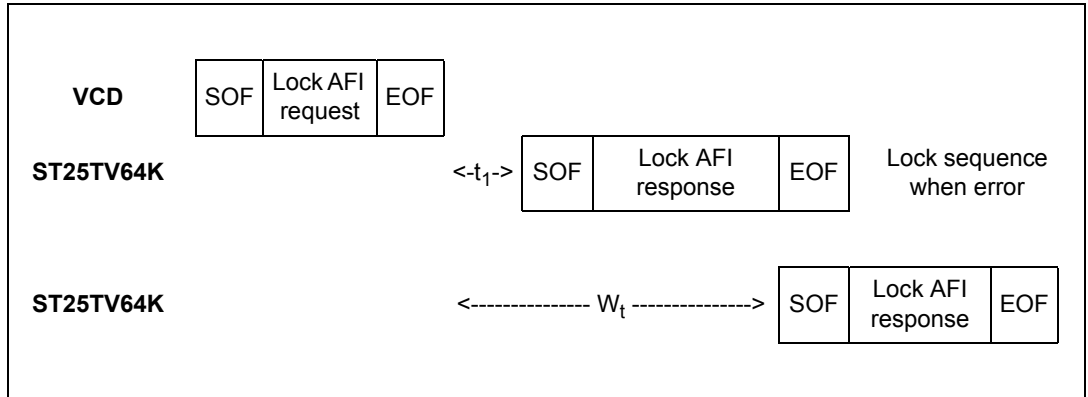

25.10 Write DSFID

On receiving the Write DSFID request, the ST25TV64K programs the 8-bit DSFID value to its memory. The Option_flag is supported.

During write cycle W_t , there should be no modulation (neither 100% nor 10%). Otherwise, the ST25TV64K may not write correctly the DSFID value in memory. The W_t time is equal to $t_{1nom} + 18 \times 302 \mu s$.

Table 54. Write DSFID request format

Request SOF	Request_flags	Write DSFID	UID ⁽¹⁾	DSFID	CRC16	Request EOF
-	8 bits	29h	64 bits	8 bits	16 bits	-

1. Gray means that the field is optional.

Request parameter:

- Request flags
- UID (optional)
- DSFID

Table 55. Write DSFID response format when Error_flag is NOT set

Response SOF	Response_flags	CRC16	Response EOF
-	8 bits	16 bits	-

Response parameter:

- No parameter

Table 56. Write DSFID response format when Error_flag is set

Response SOF	Response_flags	Error code	CRC16	Response EOF
-	8 bits	8 bits	16 bits	-

Response parameter:

- Error code as Error_flag is set
 - 12h: the specified block is locked and its contents cannot be changed.
 - 13h: the specified block was not successfully programmed

Figure 49. Write DSFID frame exchange between VCD and ST25TV64K

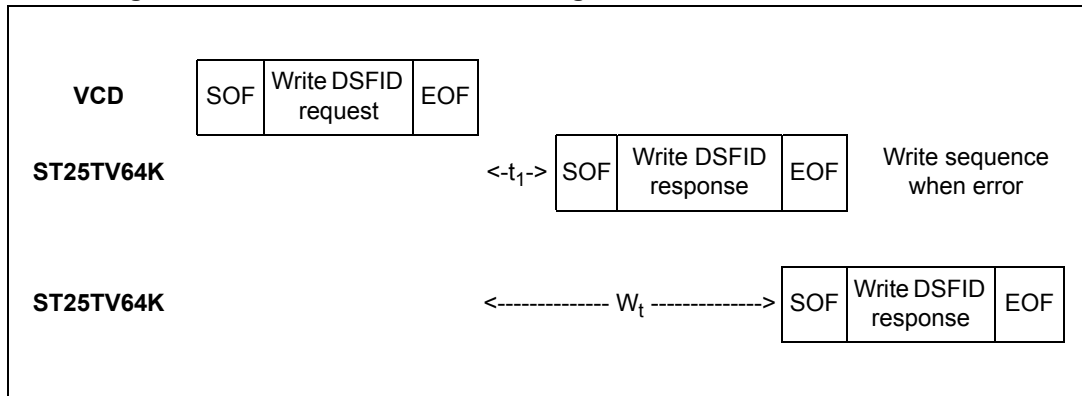

25.11 Lock DSFID

On receiving the Lock DSFID request, the ST25TV64K locks the DSFID value permanently. The Option_flag is supported.

During write cycle W_t , there should be no modulation (neither 100% nor 10%). Otherwise, the ST25TV64K may not lock correctly the DSFID value in memory. The W_t time is equal to $t_{1nom} + 18 \times 302 \mu s$.

Table 57. Lock DSFID request format

Request SOF	Request flags	Lock DSFID	UID ⁽¹⁾	CRC16	Request EOF
-	8 bits	2Ah	64 bits	16 bits	-

1. Gray means that the field is optional.

Request parameter:

- Request flags
- UID (optional)

Table 58. Lock DSFID response format when Error_flag is NOT set

Response SOF	Response flags	CRC16	Response EOF
-	8 bits	16 bits	-

Response parameter:

- No parameter.

Table 59. Lock DSFID response format when Error_flag is set

Response SOF	Response flags	Error code	CRC16	Response EOF
-	8 bits	8 bits	16 bits	-

Response parameter:

- Error code as Error_flag is set:
 - 11h: the specified block is already locked and thus cannot be locked again
 - 14h: the specified block was not successfully locked

Figure 50. Lock DSFID frame exchange between VCD and ST25TV64K

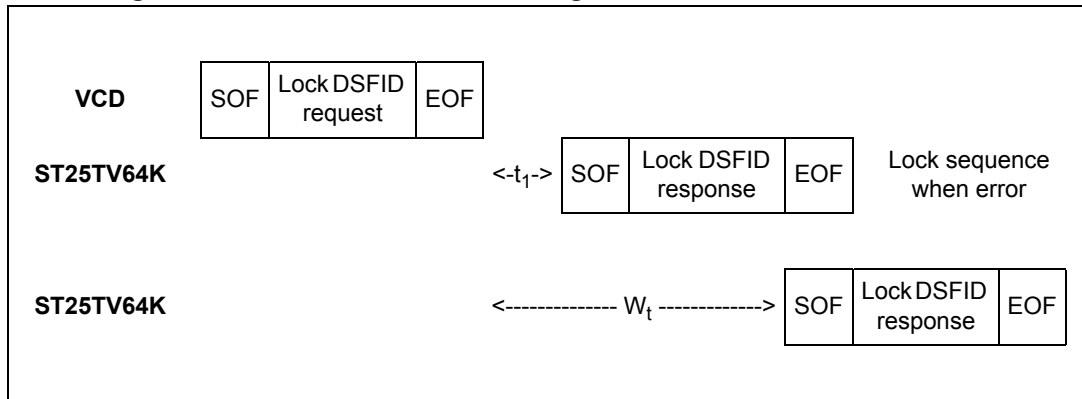

25.12 Get System Info

When receiving the Get System Info command, the ST25TV64K sends back its information data in the response. The Option_flag is supported and must be reset to 0. The Get System Info can be issued in both Addressed and Non Addressed modes.

The Protocol_extension_flag can be set to 0 or 1. [Table 61](#) and [Table 62](#) show ST25TV64K response to the Get System Info command depending on the value of the Protocol_extension_flag.

Table 60. Get System Info request format

Request SOF	Request _flags	Get System Info	UID ⁽¹⁾	CRC16	Request EOF
-	8 bits	2Bh	64 bits	16 bits	-

1. Gray means that the field is optional.

Request parameter:

- Request flags
- UID (optional)

Table 61. Get System Info response format when Protocol_extension_flag=0 and Error_flag is NOT set

Response SOF	Response _flags	Information flags	UID	DSFID	AFI	IC reference	CRC16	Response EOF
-	00h	08h	64 bits	8 bits	8 bits	5Eh	16 bits	-

Response parameters:

- Information flags set to 0Ch. DSFID, AFI and IC reference fields are present.
- UID code on 64 bits
- DSFID value
- AFI value
- ST25TV64K IC reference: the 8 bits are significant.

Table 62. Get System Info response format when Protocol_extension_flag=1 and Error_flag is NOT set

Response SOF	Response _flags	Information flags	UID	DSFID	AFI	Memory size	IC reference	CRC16	Response EOF
-	00h	0Fh	64 bits	8 bits	8 bits	0307FFh	5Eh	16 bits	-

Response parameters:

- Information flags set to 0Fh. DSFID, AFI, Memory Size and IC reference fields are present
- UID code on 64 bits
- DSFID value
- AFI value
- Memory size. The ST25TV64K provides 2048 blocks (07FFh) of 4 byte (03h)
- IC reference: the 8 bits are significant.

Table 63. Get System Info response format when Error_flag is set

Response SOF	Response_flags	Error code	CRC16	Response EOF
-	01h	8 bits	16 bits	-

Response parameter:

- Error code as Error_flag is set:
 - 03h: Option not supported

Figure 51. Get System Info frame exchange between VCD and ST25TV64K

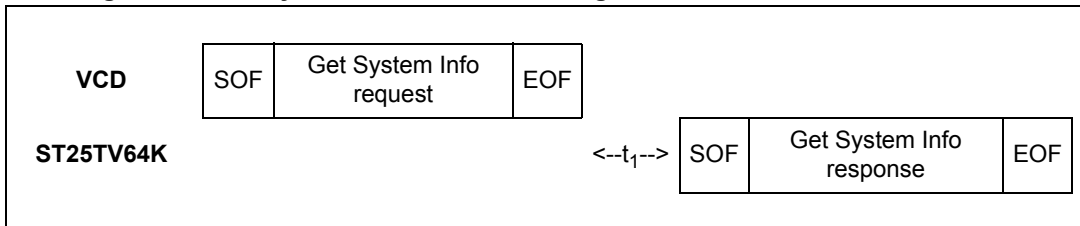

25.13 Get Multiple Block Security Status

When receiving the Get Multiple Block Security Status command, the ST25TV64K sends back the sector security status. The blocks are numbered from '00h to '07FFh' in the request and the value is minus one (-1) in the field. For example, a value of '06' in the "Number of blocks" field requests to return the security status of 7 blocks.

The Protocol_extention_flag should be set to 1 for the ST25TV64K to operate correctly. If the Protocol_extention_flag is at 0, the ST25TV64K answers with an error code.

During the ST25TV64K response, if the internal block address counter reaches 07FFh, it rolls over to 0000h and the Sector Security Status bytes for that location are sent back to the reader.

Table 64. Get Multiple Block Security Status request format

Request SOF	Request _flags	Get Multiple Block Security Status	UID ⁽¹⁾	First block number	Number of blocks	CRC16	Request EOF
-	8 bits	2Ch	64 bits	16 bits	16 bits	16 bits	-

1. Gray means that the field is optional.

Request parameter:

- Request flags
- UID (optional)
- First block number
- Number of blocks

Table 65. Get Multiple Block Security Status response format when Error_flag is NOT set

Response SOF	Response_flags	Sector security status	CRC16	Response EOF
-	8 bits	8 bits ⁽¹⁾	16 bits	-

1. Repeated as needed.

Response parameters:

- Sector security status (see [Table 66](#))

Table 66. Sector security status

b ₇	b ₆	b ₅	b ₄	b ₃	b ₂	b ₁	b ₀
Reserved for future use. All at 0			Password control bits		Read / Write protection bits		0: Current sector not locked 1: Current sector locked

Table 67. Get Multiple Block Security Status response format when Error_flag is set

Response SOF	Response_flags	Error code	CRC16	Response EOF
-	8 bits	8 bits	16 bits	-

Response parameter:

- Error code as Error_flag is set:
 - 03h: the option is not supported
 - 10h: the specified block is not available

Figure 52. Get Multiple Block Security Status frame exchange between VCD and ST25TV64K

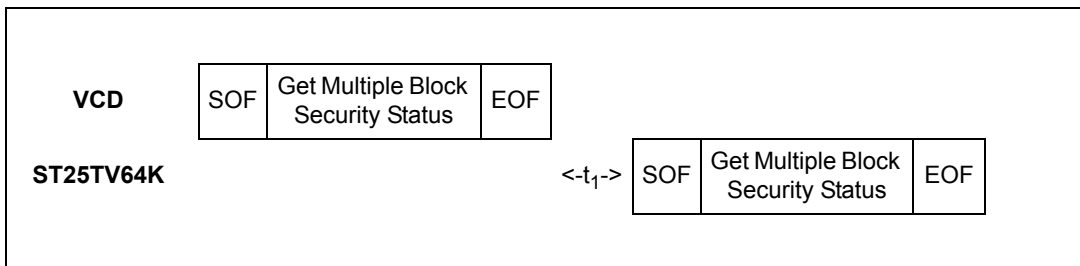

25.14 Write-sector Password

On receiving the Write-sector Password command, the ST25TV64K uses the data contained in the request to write the password and reports whether the operation was successful in the response. The Option_flag is supported.

During write cycle time W_t , there must be no modulation at all (neither 100% nor 10%). Otherwise, the ST25TV64K may not correctly program the data into the memory. The W_t time is equal to $t_{1nom} + 18 \times 302 \mu s$. After a successful write, the new value of the selected password is automatically activated. It is not required to present the new password value until the ST25TV64K powers-down.

Table 68. Write-sector Password request format

Request SOF	Request _flags	Write-sector Password	IC Mfg code	UID ⁽¹⁾	Password number	Data	CRC16	Request EOF
-	8 bits	B1h	02h	64 bits	8 bits	32 bits	16 bits	-

1. Gray means that the field is optional.

Request parameter:

- Request flags
- UID (optional)
- Password number (01h = Pswd1, 02h = Pswd2, 03h = Pswd3, other = Error)
- Data

Table 69. Write-sector Password response format when Error_flag is NOT set

Response SOF	Response_flags	CRC16	Response EOF
-	8 bits	16 bits	-

Response parameter:

- No parameter.

Table 70. Write-sector Password response format when Error_flag is set

Response SOF	Response_flags	Error code	CRC16	Response EOF
-	8 bits	8 bits	16 bits	-

Response parameter:

- Error code as Error_flag is set:
 - 10h: the password number is incorrect
 - 12h: the session was not opened before the password update
 - 13h: the specified block was not successfully programmed
 - 0Fh: the presented password is incorrect

Figure 53. Write-sector Password frame exchange between VCD and ST25TV64K

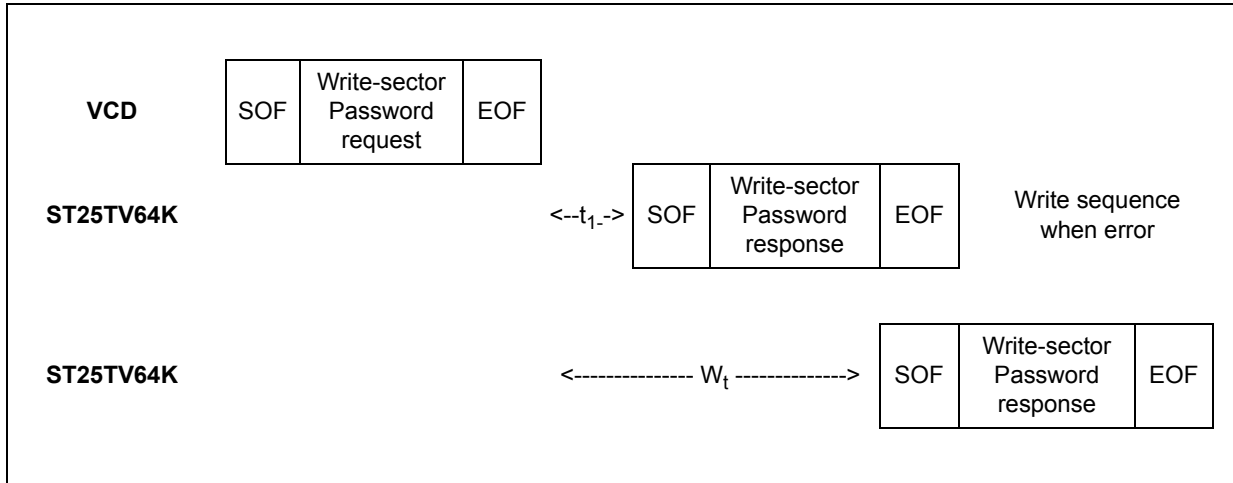

25.15 Lock-Sector

On receiving the Lock-Sector command, the ST25TV64K sets the access rights and permanently locks the selected sector. The Option_flag is supported.

A sector is selected by giving the address of one of its blocks in the Lock-Sector request (Sector number field). For example, addresses 0 to 31 are used to select sector 0 and addresses 32 to 63 are used to select sector 1. Care must be taken when issuing the Lock-Sector command as all the blocks belonging to the same sector are automatically locked by a single command.

The Protocol_extention_flag should be set to 1 for the ST25TV64K to operate correctly. If the Protocol_extention_flag is at 0, the ST25TV64K answers with an error code.

During write cycle W_t , there should be no modulation (neither 100% nor 10%) otherwise, the ST25TV64K may not correctly lock the memory block.

The W_t time is equal to $t_{1nom} + 18 \times 302 \mu s$.

Table 71. Lock-Sector request format

Request SOF	Request _flags	Lock-Sector	IC Mfg code	UID ⁽¹⁾	Sector number	Sector security status	CRC16	Request EOF
-	8 bits	B2h	02h	64 bits	16 bits	8 bits	16 bits	-

1. Gray means that the field is optional.

Request parameters:

- Request flags
- (optional) UID
- Sector number
- Sector security status (refer to [Table 72](#))

Table 72. Sector security status

b ₇	b ₆	b ₅	b ₄	b ₃	b ₂	b ₁	b ₀
0	0	0	Password control bits		Read / Write protection bits		1

Table 73. Lock-Sector response format when Error_flag is NOT set

Response SOF	Response_flags	CRC16	Response EOF
-	8 bits	16 bits	-

Response parameter:

- No parameter.

Table 74. Lock-Sector response format when Error_flag is set

Response SOF	Response_flags	Error code	CRC16	Response EOF
-	8 bits	8 bits	16 bits	-

Response parameter:

- Error code as Error_flag is set:
 - 10h: the specified block is not available
 - 11h: the specified block is already locked and thus cannot be locked again
 - 14h: the specified block was not successfully locked

Figure 54. Lock-Sector frame exchange between VCD and ST25TV64K

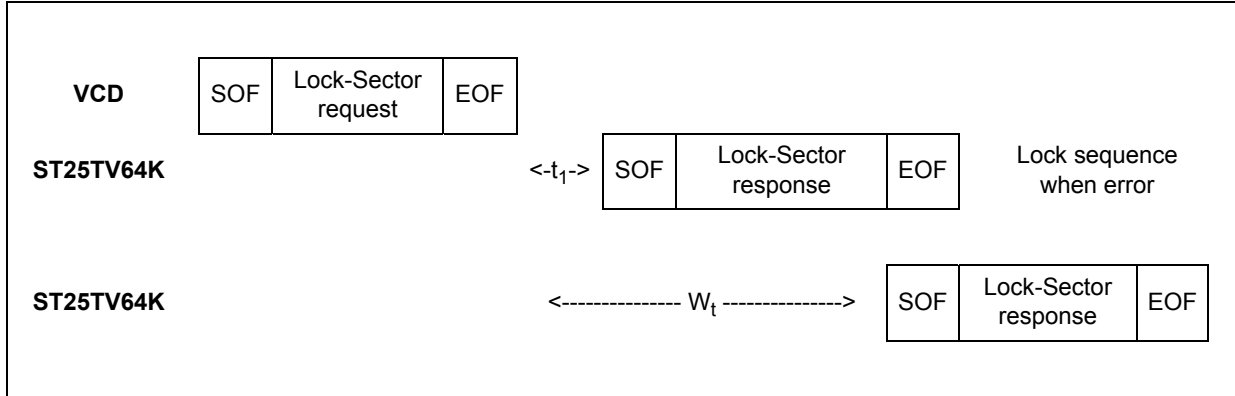

25.16 Present-sector Password

On receiving the Present-sector Password command, the ST25TV64K compares the requested password with the data contained in the request and reports whether the operation has been successful in the response. The Option_flag is supported. During the W_t comparison cycle time, there should be no modulation (neither 100% nor 10%) otherwise, the ST25TV64K Password value may not be correctly compared. The W_t time is equal to $t_{1nom} + 18 \times 302 \mu s$. After a successful command, the access to all the memory blocks linked to the password is changed as described in [Section 4.1: ST25TV64K RF block security](#).

Table 75. Present-sector Password request format

Request SOF	Request _flags	Present-sector Password	IC Mfg code	UID ⁽¹⁾	Password number	Password	CRC16	Request EOF
-	8 bits	B3h	02h	64 bits	8 bits	32 bits	16 bits	-

1. Gray means that the field is optional.

Request parameter:

- Request flags
- UID (optional)
- Password Number (0x01 = Pswd1, 0x02 = Pswd2, 0x03 = Pswd3, other = Error)
- Password

Table 76. Present-sector Password response format when Error_flag is NOT set

Response SOF	Response_flags	CRC16	Response EOF
-	8 bits	16 bits	-

Response parameter:

- No parameter. The response is send back after the writing cycle

Table 77. Present-sector Password response format when Error_flag is set

Response SOF	Response_flags	Error code	CRC16	Response EOF
-	8 bits	8 bits	16 bits	-

Response parameter:

- Error code as Error_flag is set:
 - 10h: the password number is incorrect
 - 0Fh: the present password is incorrect

Figure 55. Present-sector Password frame exchange between VCD and ST25TV64K

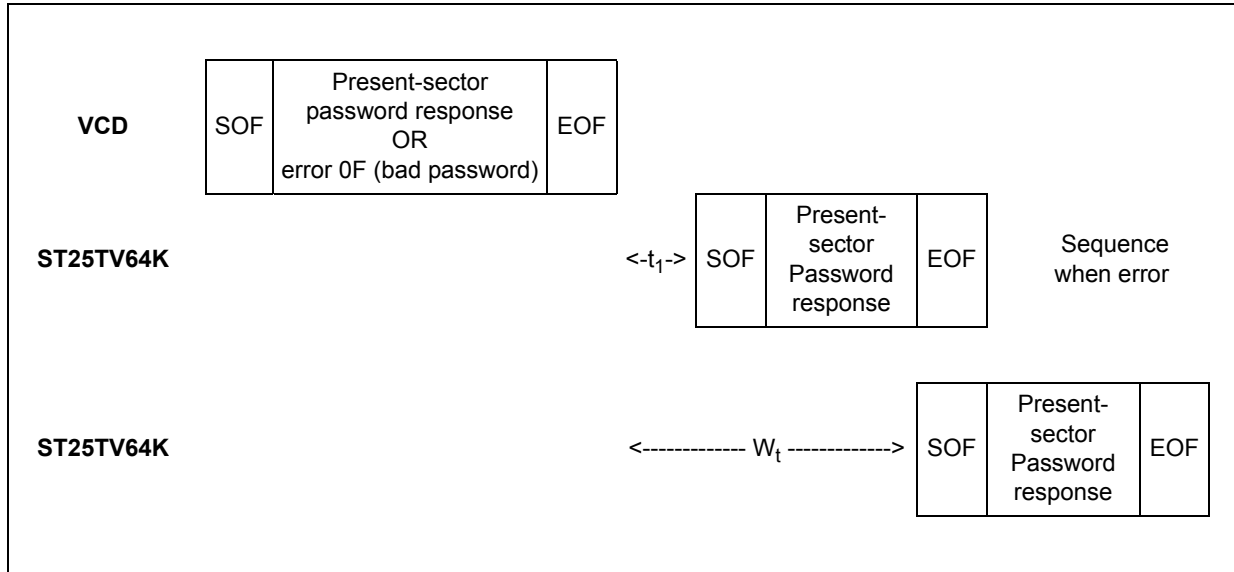

25.17 Fast Read Single Block

On receiving the Fast Read Single Block command, the ST25TV64K reads the requested block and sends back its 32-bit value in the response. The Option_flag is supported. The data rate of the response is multiplied by 2.

The Protocol_extention_flag should be set to 1 for the ST25TV64K to operate correctly. If the Protocol_extention_flag is at 0, the ST25TV64K answers with an error code.

Table 78. Fast Read Single Block request format

Request SOF	Request_flags	Fast Read Single Block	IC Mfg code	UID ⁽¹⁾	Block number	CRC16	Request EOF
-	8 bits	C0h	02h	64 bits	16 bits	16 bits	-

1. Gray means that the field is optional.

Request parameters:

- Request flags
- UID (optional)
- Block number

Table 79. Fast Read Single Block response format when Error_flag is NOT set

Response SOF	Response_flags	Sector security status ⁽¹⁾	Data	CRC16	Response EOF
-	8 bits	8 bits	32 bits	16 bits	-

1. Gray means that the field is optional.

Response parameters:

- Sector security status if Option_flag is set (see [Table 80](#))
- 4 bytes of block data

Table 80. Sector security status

b ₇	b ₆	b ₅	b ₄	b ₃	b ₂	b ₁	b ₀
Reserved for future used. All at 0		Password control bits		Read / Write protection bits		0: Current sector not locked 1: Current sector locked	

Table 81. Fast Read Single Block response format when Error_flag is set

Response SOF	Response_flags	Error code	CRC16	Response EOF
-	8 bits	8 bits	16 bits	-

Response parameter:

- Error code as Error_flag is set:
 - 10h: the specified block is not available
 - 15h: the specified block is read protected

Figure 56. Fast Read Single Block frame exchange between VCD and ST25TV64K

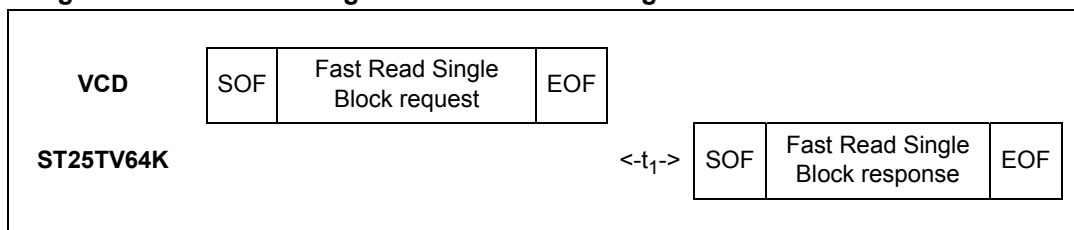

25.18 Fast Inventory Initiated

Before receiving the Fast Inventory Initiated command, the ST25TV64K must have received an Initiate or a Fast Initiate command in order to set the Initiate_flag. If not, the ST25TV64K does not answer to the Fast Inventory Initiated command.

The subcarrier_flag should be set to 0, otherwise the ST25TV64K answers with an error code.

On receiving the Fast Inventory Initiated request, the ST25TV64K runs the anticollision sequence. The Inventory_flag must be set to 1. The meaning of flags 5 to 8 is shown in [Table 20: Request flags 5 to 8 when Bit 3 = 1 on page 45](#). The data rate of the response is multiplied by 2.

The request contains:

- the flags,
- the Inventory command code
- the AFI if the AFI flag is set
- the mask length
- the mask value
- the CRC

The ST25TV64K does not generate any answer in case of error.

Table 82. Fast Inventory Initiated request format

Request SOF	Request _flags	Fast Inventory Initiated	IC Mfg code	Optional AFI ⁽¹⁾	Mask length	Mask value	CRC16	Request EOF
-	8 bits	C1h	02h	8 bits	8 bits	0 - 64 bits	16 bits	-

1. Gray means that the field is optional.

The Response contains:

- the flags
- the Unique ID

Table 83. Fast Inventory Initiated response format

Response SOF	Response_flags	DSFID	UID	CRC16	Response EOF
-	8 bits	8 bits	64 bits	16 bits	-

During an Inventory process, if the VCD does not receive an RF ST25TV64K response, it waits a time t_3 before sending an EOF to switch to the next slot. t_3 starts from the rising edge of the request EOF sent by the VCD.

- If the VCD sends a 100% modulated EOF, the minimum value of t_3 is:

$$t_{3min} = 4384/f_C (323.3\mu s) + t_{SOF}$$
- If the VCD sends a 10% modulated EOF, the minimum value of t_3 is:

$$t_{3min} = 4384/f_C (323.3\mu s) + t_{NRT}$$

where:

- t_{SOF} is the time required by the ST25TV64K to transmit an SOF to the VCD
- t_{NRT} is the nominal response time of the ST25TV64K

t_{NRT} and t_{SOF} are dependent on the ST25TV64K-to-VCD data rate and from the subcarrier modulation mode.

25.19 Fast Initiate

On receiving the Fast Initiate command, the ST25TV64K will set the internal Initiate_flag and send back a response only if it is in the Ready state. The command has to be issued in the Non Addressed mode only (Select_flag is reset to 0 and Address_flag is reset to 0). If an error occurs, the ST25TV64K does not generate any answer. The Initiate_flag is reset after a power off of the ST25TV64K. The data rate of the response is multiplied by 2.

The request contains:

- No data

Table 84. Fast Initiate request format

Request SOF	Request_flags	Fast Initiate	IC Mfg Code	CRC16	Request EOF
-	8 bits	C2h	02h	16 bits	-

The response contains:

- the flags
- the Unique ID

Table 85. Fast Initiate response format

Response SOF	Response_flags	DSFID	UID	CRC16	Response EOF
-	8 bits	8 bits	64 bits	16 bits	-

Figure 57. Fast Initiate frame exchange between VCD and ST25TV64K

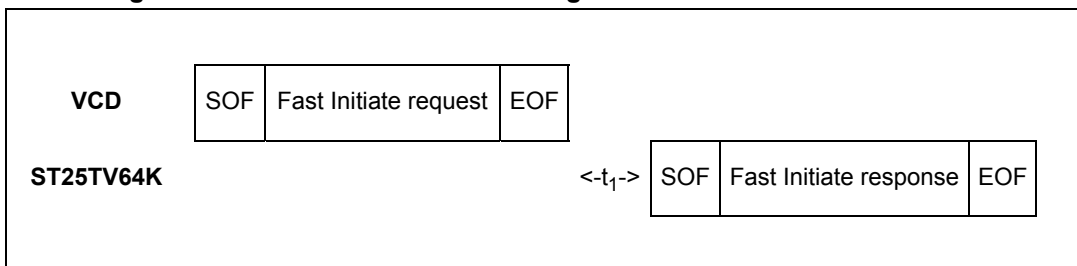

25.20 Fast Read Multiple Block

On receiving the Fast Read Multiple Block command, the ST25TV64K reads the selected blocks and sends back their value in multiples of 32 bits in the response. The blocks are numbered from '00h to '07FFh' in the request and the value is minus one (-1) in the field. For example, if the “number of blocks” field contains the value 06h, 7 blocks are read. The maximum number of blocks is fixed to 32 assuming that they are all located in the same sector. If the number of blocks overlaps sectors, the ST25TV64K returns an error code.

The Protocol_extention_flag should be set to 1 for the ST25TV64K to operate correctly. If the Protocol_extention_flag is at 0, the ST25TV64K answers with an error code.

The Option_flag is supported. The data rate of the response is multiplied by 2.

The subcarrier_flag should be set to 0, otherwise the ST25TV64K will answer with an error code.

Table 86. Fast Read Multiple Block request format

Request SOF	Request flags	Fast Read Multiple Block	IC Mfg code	UID ⁽¹⁾	First block number	Number of blocks	CRC16	Request EOF
-	8 bits	C3h	02h	64 bits	16 bits	8 bits	16 bits	-

1. Gray means that the field is optional.

Request parameters:

- Request flags
- UID (Optional)
- First block number
- Number of blocks

Table 87. Fast Read Multiple Block response format when Error_flag is NOT set

Response SOF	Response flags	Sector security status ⁽¹⁾	Data	CRC16	Response EOF
-	8 bits	8 bits ⁽²⁾	32 bits ⁽²⁾	16 bits	-

1. Gray means that the field is optional.

2. Repeated as needed.

Response parameters:

- Sector security status if Option_flag is set (see [Table 88](#))
- N block of data

Table 88. Sector security status if Option_flag is set

b ₇	b ₆	b ₅	b ₄	b ₃	b ₂	b ₁	b ₀
Reserved for future use. All at 0		Password control bits		Read / Write protection bits		0: Current sector not locked 1: Current sector locked	

Table 89. Fast Read Multiple Block response format when Error_flag is set

Response SOF	Response_flags	Error code	CRC16	Response EOF
-	8 bits	8 bits	16 bits	-

Response parameter:

- Error code as Error_flag is set:
 - 03h: the option is not supported
 - 10h: block address not available
 - 15h: block read-protected

Figure 58. Fast Read Multiple Block frame exchange between VCD and ST25TV64K

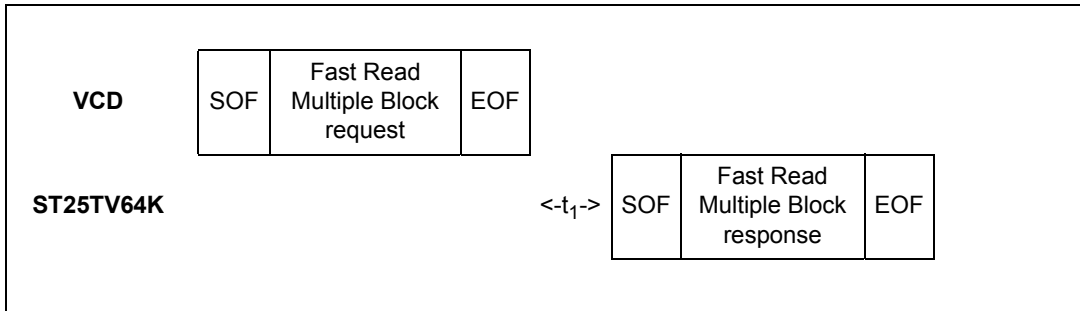

25.21 Inventory Initiated

Before receiving the Inventory Initiated command, the ST25TV64K must have received an Initiate or a Fast Initiate command in order to set the Initiate_ flag. If not, the ST25TV64K does not answer to the Inventory Initiated command.

On receiving the Inventory Initiated request, the ST25TV64K runs the anticollision sequence. The Inventory_ flag must be set to 1. The meaning of flags 5 to 8 is given in [Table 20: Request flags 5 to 8 when Bit 3 = 1 on page 45](#).

The request contains:

- the flags,
- the Inventory Command code
- the AFI if the AFI flag is set
- the mask length
- the mask value
- the CRC

The ST25TV64K does not generate any answer in case of error.

Table 90. Inventory Initiated request format

Request SOF	Request _flags	Inventory Initiated	IC Mfg code	Optional AFI	Mask length	Mask value	CRC16	Request EOF
-	8 bits	D1h	02h	8 bits	8 bits	0 - 64 bits	16 bits	-

The response contains:

- the flags
- the Unique ID

Table 91. Inventory Initiated response format

Response SOF	Response _flags	DSFID	UID	CRC16	Response EOF
-	8 bits	8 bits	64 bits	16 bits	-

During an Inventory process, if the VCD does not receive an RF ST25TV64K response, it waits a time t_3 before sending an EOF to switch to the next slot. t_3 starts from the rising edge of the request EOF sent by the VCD.

- If the VCD sends a 100% modulated EOF, the minimum value of t_3 is:
 $t_{3min} = 4384/f_C (323.3\mu s) + t_{SOF}$
- If the VCD sends a 10% modulated EOF, the minimum value of t_3 is:
 $t_{3min} = 4384/f_C (323.3\mu s) + t_{NRT}$

where:

- t_{SOF} is the time required by the ST25TV64K to transmit an SOF to the VCD
- t_{NRT} is the nominal response time of the ST25TV64K

t_{NRT} and t_{SOF} are dependent on the ST25TV64K-to-VCD data rate and subcarrier modulation mode.

25.22 Initiate

On receiving the Initiate command, the ST25TV64K will set the internal Initiate_flag and send back a response only if it is in the ready state. The command has to be issued in the Non Addressed mode only (Select_flag is reset to 0 and Address_flag is reset to 0). If an error occurs, the ST25TV64K does not generate any answer. The Initiate_flag is reset after a power off of the ST25TV64K.

The request contains:

- No data

Table 92. Initiate request format

Request SOF	Request_flags	Initiate	IC Mfg code	CRC16	Request EOF
-	8 bits	D2h	02h	16 bits	-

The response contains:

- the flags
- the Unique ID

Table 93. Initiate Initiated response format

Response SOF	Response_flags	DSFID	UID	CRC16	Response EOF
-	8 bits	8 bits	64 bits	16 bits	-

Figure 59. Initiate frame exchange between VCD and ST25TV64K

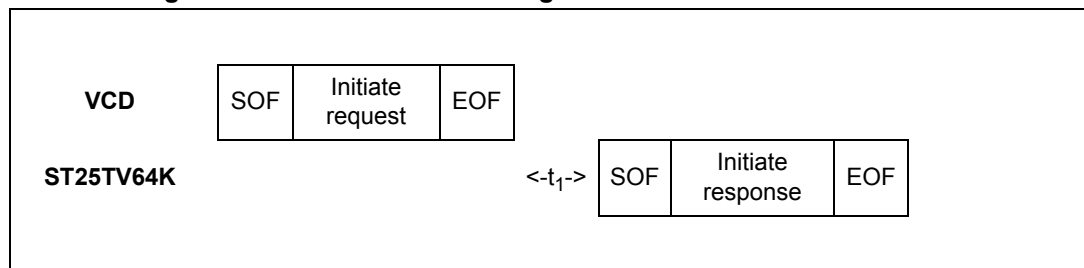

26 Maximum ratings

Stressing the device above the ratings listed in [Table 94](#) may cause permanent damage to the it. These are stress ratings only, and operation of the device at these or any other conditions above those indicated in the operating sections of this specification is not implied. Exposure to absolute maximum ratings conditions for extended periods may affect device reliability.

Table 94. Absolute maximum ratings

Symbol	Parameter		Min.	Max.	Unit
T_{STG}	Storage temperature	Sawn bumped wafer (kept in its antistatic bag)	15	25	°C
t_{STG}	Storage time		-	9 ⁽¹⁾	months
T_A	Ambient operating temperature		-40	85	°C
$I_{CC}^{(2)}$	Supply current on AC0/AC1		-	50	mA
$V_{MAX_1}^{(2)}$	RF input voltage amplitude, peak to peak between AC0 and AC1, GND pad left floating	VAC0-VAC1	-	27	V
$V_{MAX_2}^{(2)}$	AC voltage between AC0 and AC1, or AC1 and GND	VAC0-GND, or VAC1-GND	-1	11	
V_{ESD}	Electrostatic discharge voltage (Human Body Model, or HBM) ⁽³⁾	AC0, AC1	-	1000	V
		Other pads	-	3500	
	Electrostatic discharge voltage on Antenna ⁽⁴⁾	AC0, AC1	-	4000	

1. Counted from ST shipment date.
2. Based on characterization, not tested in production.
3. AEC-Q100-002 (compliant with JEDEC Std JESD22-A114, C1 = 100 pF, R1 = 1500 Ω , R2 = 500 Ω)
4. Compliant with IEC 61000-4-3 method (ST25TV64K packaged in S08N is mounted on ST reference antenna ANT1- ST25TV64K).

27 RF electrical parameters

This section summarizes the operating and measurement conditions, and the DC and AC characteristics of the device in RF mode. The parameters in the DC and AC Characteristic tables that follow are derived from tests performed under the Measurement Conditions summarized in the relevant tables. Designers should check that the operating conditions in their circuit match the measurement conditions when relying on the quoted parameters.

Table 95. RF characteristics^{(1) (2)}

Symbol	Parameter	Condition	Min	Typ	Max	Unit
f_{CC}	External RF signal frequency	-	13.553	13.56	13.567	MHz
H_ISO	Operating field according to ISO	$T_A = -40\text{ °C to }85\text{ °C}$	150	-	5000	mA/m
MI _{CARRIER}	10% carrier modulation index ⁽³⁾ $MI=(A-B)/(A+B)$	$150\text{ mA/m} > H_ISO > 1000\text{ mA/m}$	15	-	30	%
		$H_ISO > 1000\text{ mA/m}$	10	-	30	
t_{RFR}, t_{RFF}	10% rise and fall time	-	0.5	-	3.0	μs
t_{RFSBL}	10% minimum pulse width for bit	-	7.1	-	9.44	μs
MI _{CARRIER}	100% carrier modulation index	$MI=(A-B)/(A+B)^{(4)}$	95	-	100	%
t_{RFR}, t_{RFF}	100% rise and fall time	-	0.5	-	3.5	μs
t_{RFSBL}	100% minimum pulse width for bit	-	7	-	9.44	μs
$t_{MIN\ CD}$	Minimum time from carrier generation to first data	From H-field min	-	-	1	ms
f_{SH}	Subcarrier frequency high	$f_{CC}/32$	-	423.75	-	kHz
f_{SL}	Subcarrier frequency low	$f_{CC}/28$	-	484.28	-	kHz
t_1	Time for ST25TV64K response	$4224/f_S$	318.6	320.9	323.3	μs
t_2	Time between commands	$4224/f_S$	309	311.5	314	μs
W_t	RF write time (including internal Verify)	-	-	5.75	-	ms
I_{CC_RF}	Operating current (Read) ⁽⁵⁾	VAC0-VAC1 (4 V peak to peak)	-	20	-	μA
C_{TUN}	Internal tuning capacitor in SO8 ⁽⁶⁾	$f = 13.56\text{ MHz}$	24.8	27.5	30.2	pF
V_{BACK}	Backscattered level as defined by ISO test	ISO10373-7	10	-	-	mV
$V_{MAX_1}^{(3)}$	RF input voltage amplitude between AC0 and AC1, GND pad left floating, VAC0-VAC1 peak to peak ⁽⁷⁾	-	-	-	20	V
$V_{MAX_2}^{(3)}$	AC voltage between AC0 and GND or between AC1 and GND	-	-1	-	8.5	V
$V_{MIN_1}^{(3)}$	RF input voltage amplitude between AC0 and AC1, GND pad left floating, VAC0-VAC1 peak to peak ⁽⁷⁾	Inventory and Read operations	-	4	4.5	V
		Write operations	-	4.5	5	V

Table 95. RF characteristics^{(1) (2)} (continued)

Symbol	Parameter	Condition	Min	Typ	Max	Unit
V _{MIN_2} ⁽³⁾	AC voltage between AC0 and GND or between AC1 and GND	Inventory and Read operations	-	1.8	2	V
		Write operations	-	2	2.2	V
t _{RF_OFF}	RF OFF time	Chip reset	2	-	-	ms

1. T_A = -40 to 85 °C. Characterized only.
2. All timing characterizations were performed on a reference antenna with the following characteristics:
 External size: 75 mm x 48 mm
 Number of turns: 5
 Width of conductor: 0.5 mm
 Space between two conductors: 0.3 mm
 Value of the tuning capacitor in SO8: 27.5 pF (ST25TV64K)
 Value of the coil: 5 µH
 Tuning frequency: 13.56 MHz.
3. 15% (or more) carrier modulation index offers a better signal/noise ratio and therefore a wider operating range with a better noise immunity.
4. Temperature range 0 °C to 90 °C.
5. Characterized on bench.
6. Characterized only, at room temperature only, measured at VAC0-VAC1 = 1 V peak to peak.
7. Characterized only, at room temperature only.

Table 96. Operating conditions

Symbol	Parameter	Min.	Max.	Unit
T _A	Ambient operating temperature	-40	85	°C

Figure 60 shows an ASK modulated signal, from the VCD to the ST25TV64K. The test condition for the AC/DC parameters are:

- Close coupling condition with tester antenna (1mm)
- ST25TV64K performance measured at the tag antenna
- ST25TV64K synchronous timing, transient and receive

Figure 60. ASK modulated signal

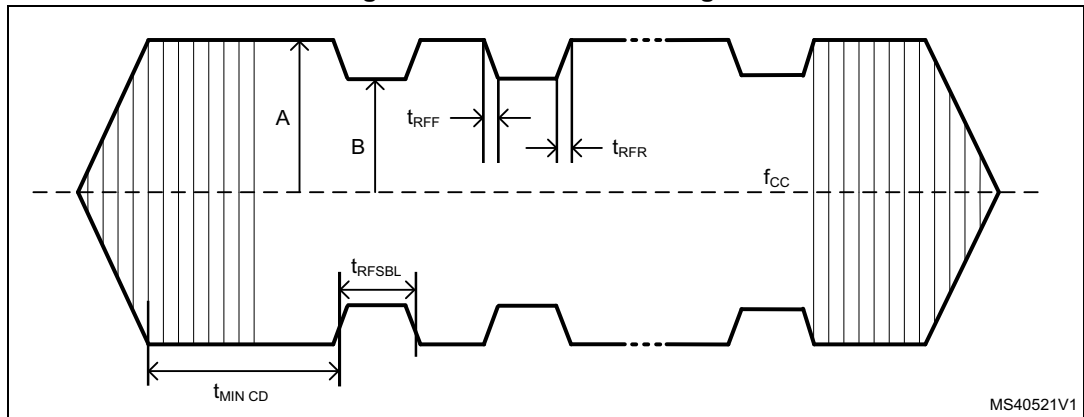

28 Part numbering

Table 97. Ordering information scheme

	ST25	T	V	64K	-A	P	6	B	3
Device type	ST25 = RF memory								
Product type	T = Tags + RFID								
Protocol	V = ISO15693								
Memory density	64K (binary)								
Interface	A = none								
Features	P = Password as option								
Operating temperature	6 = -40 to 85 °C								
Package	B = Bumped 120 μm								
Capacitor	3 = 27.5 pF								

For a list of available options or for further information on any aspect of this device, contact your nearest ST sales office.

Appendix A Anticollision algorithm

The following pseudocode describes how anticollision could be implemented on the VCD, using recursivity.

A.1 Algorithm for pulsed slots

```

function push (mask, address); pushes on private stack
function pop (mask, address); pops from private stack
function pulse_next_pause; generates a power pulse
function store(ST25TV64K_UID); stores ST25TV64K_UID

function poll_loop (sub_address_size as integer)
  pop (mask, address)
  mask = address & mask; generates new mask
    ; send the request
  mode = anticollision
  send_Request (Request_cmd, mode, mask length, mask value)
  for sub_address = 0 to (2^sub_address_size - 1)
    pulse_next_pause
    if no_collision_is_detected ; ST25TV64K is inventoried
      then
        store (ST25TV64K_UID)
      else ; remember a collision was detected
        push(mask,address)
      endif
    next sub_address

  if stack_not_empty ; if some collisions have been detected and
    then ; not yet processed, the function calls itself
      poll_loop (sub_address_size); recursively to process the last
stored collision
    endif
end poll_loop

main_cycle:
  mask = null
  address = null
  push (mask, address)
  poll_loop(sub_address_size)
end_main_cycle

```

Appendix B CRC

B.1 CRC error detection method

The cyclic redundancy check (CRC) is calculated on all data contained in a message, from the start of the flags through to the end of Data. The CRC is used from VCD to ST25TV64K and from ST25TV64K to VCD.

Table 98. CRC definition

CRC definition					
CRC type	Length	Polynomial	Direction	Preset	Residue
ISO/IEC 13239	16 bits	$X^{16} + X^{12} + X^5 + 1 = 8408h$	Backward	FFFFh	F0B8h

To add extra protection against shifting errors, a further transformation on the calculated CRC is made. The One's Complement of the calculated CRC is the value attached to the message for transmission.

To check received messages the 2 CRC bytes are often also included in the re-calculation, for ease of use. In this case, the expected value for the generated CRC is the residue F0B8h.

B.2 CRC calculation example

This example in C language illustrates one method of calculating the CRC on a given set of bytes comprising a message.

C-example to calculate or check the CRC16 according to ISO/IEC 13239

```
#define POLYNOMIAL0x8408// x^16 + x^12 + x^5 + 1
#define PRESET_VALUE0xFFFF
#define CHECK_VALUE0xF0B8

#define NUMBER_OF_BYTES4// Example: 4 data bytes
#define CALC_CRC1
#define CHECK_CRC0

void main()
{
    unsigned int current_crc_value;
    unsigned char array_of_databytes[NUMBER_OF_BYTES + 2] = {1, 2, 3, 4, 0x91,
0x39};
    int number_of_databytes = NUMBER_OF_BYTES;
    int calculate_or_check_crc;
    int i, j;
    calculate_or_check_crc = CALC_CRC;
    // calculate_or_check_crc = CHECK_CRC;// This could be an other example
```

```
if (calculate_or_check_crc == CALC_CRC)
{
    number_of_databytes = NUMBER_OF_BYTES;
}
else // check CRC
{
    number_of_databytes = NUMBER_OF_BYTES + 2;
}

current_crc_value = PRESET_VALUE;

for (i = 0; i < number_of_databytes; i++)
{
    current_crc_value = current_crc_value ^ ((unsigned
int)array_of_databytes[i]);

    for (j = 0; j < 8; j++)
    {
        if (current_crc_value & 0x0001)
        {
            current_crc_value = (current_crc_value >> 1) ^ POLYNOMIAL;
        }
        else
        {
            current_crc_value = (current_crc_value >> 1);
        }
    }
}

if (calculate_or_check_crc == CALC_CRC)
{
    current_crc_value = ~current_crc_value;

    printf ("Generated CRC is 0x%04X\n", current_crc_value);

    // current_crc_value is now ready to be appended to the data stream
    // (first LSByte, then MSByte)
}
else // check CRC
{
    if (current_crc_value == CHECK_VALUE)
    {
        printf ("Checked CRC is ok (0x%04X)\n", current_crc_value);
    }
    else
```

```
    {  
        printf ("Checked CRC is NOT ok (0x%04X)\n", current_crc_value);  
    }  
}  
}
```

Appendix C Application family identifier (AFI)

The AFI (application family identifier) represents the type of application targeted by the VCD, and is used to extract from all the ST25TV64K present only the one meeting the required application criteria.

It is programmed by the ST25TV64K issuer (the purchaser of the ST25TV64K). Once locked, it cannot be modified.

The most significant nibble of the AFI is used to code one specific or all application families, as defined in [Table 99](#).

The least significant nibble of the AFI is used to code one specific or all application subfamilies. Subfamily codes different from 0 are proprietary.

Table 99. AFI coding⁽¹⁾

AFI Most significant nibble	AFI Least significant nibble	Meaning VICCs respond from	Examples / Note
'0'	'0'	All families and subfamilies	No applicative preselection
'X'	'0'	All subfamilies of family X	Wide applicative preselection
'X'	'Y'	Only the Yth subfamily of family X	-
'0'	'Y'	Proprietary subfamily Y only	-
'1'	"0", 'Y'	Transport	Mass transit, bus, airline, etc.
'2'	"0", 'Y'	Financial	IEP, banking, retail, etc.
'3'	"0", 'Y'	Identification	Access control, etc.
'4'	"0", 'Y'	Telecommunication	Public telephony, GSM, etc.
'5'	'0', 'Y'	Medical	-
'6'	"0", 'Y'	Multimedia	Internet services, etc.
'7'	"0", 'Y'	Gaming	-
'8'	"0", 'Y'	Data storage	Portable files, etc.
'9'	"0", 'Y'	Item management	-
'A'	"0", 'Y'	Express parcels	-
'B'	"0", 'Y'	Postal services	-
'C'	"0", 'Y'	Airline bags	-
'D'	"0", 'Y'	RFU	-
'E'	"0", 'Y'	RFU	-
'F'	'0', 'Y'	RFU	-

1. X = '1' to 'F', Y = '1' to 'F'

Revision history

Table 100. Document revision history

Date	Revision	Changes
27-Jan-2016	1	Initial release.
28-Apr-2016	2	Updated Figure 2: Memory sector organization and Figure 41: Stay Quiet frame exchange between VCD and ST25TV64K . Updated Table 12: UID format . Updated Section 25.13: Get Multiple Block Security Status and Section 25.20: Fast Read Multiple Block .

IMPORTANT NOTICE – PLEASE READ CAREFULLY

STMicroelectronics NV and its subsidiaries ("ST") reserve the right to make changes, corrections, enhancements, modifications, and improvements to ST products and/or to this document at any time without notice. Purchasers should obtain the latest relevant information on ST products before placing orders. ST products are sold pursuant to ST's terms and conditions of sale in place at the time of order acknowledgement.

Purchasers are solely responsible for the choice, selection, and use of ST products and ST assumes no liability for application assistance or the design of Purchasers' products.

No license, express or implied, to any intellectual property right is granted by ST herein.

Resale of ST products with provisions different from the information set forth herein shall void any warranty granted by ST for such product.

ST and the ST logo are trademarks of ST. All other product or service names are the property of their respective owners.

Information in this document supersedes and replaces information previously supplied in any prior versions of this document.

© 2016 STMicroelectronics – All rights reserved

