



ST491A

Low power high speed
RS-485/RS-422 transceiver

General features

- Low supply current: 5mA max
- Designed for RS485 interface applications
- -7V to 12V common mode input voltage range
- 70mV typical input hysteresis
- Designed for 25Mbps operation
- Operate from a single 5V supply
- ± 4 kV ESD protection
- Current limiting and thermal shutdown for driver overload protection

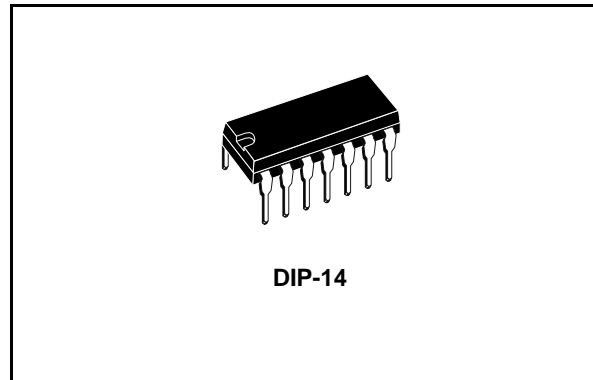

Description

The ST491A is a low power transceiver for RS-485 and RS-422 communications. The device contains one driver and one receiver in full duplex configuration. The ST491A draws 5mA (typ.) of supply current when unloaded and operates from a single 5V supply.

Driver is short-circuit current limited and is protected against excessive power dissipation by thermal shutdown circuitry that place the driver outputs into a high-impedance state. The receiver input has a fail-safe feature that guarantees a logic high output if both inputs are open circuit.

Order code

| Part number | Temperature range | Package | Packaging |
|-------------|-------------------|---------|-----------------------------------|
| ST491ACN | 0 to 70 °C | DIP-14 | 25parts per tube / 40tube per box |
| ST491ABN | -40 to 85 °C | DIP-14 | 25parts per tube / 40tube per box |

Contents

| | | |
|---|--|----|
| 1 | Pin configuration | 3 |
| 2 | Truth tables | 4 |
| 3 | Maximum ratings | 5 |
| 4 | Electrical characteristics | 6 |
| 5 | Test circuit and typical characteristics | 9 |
| 6 | Package mechanical data | 14 |
| 7 | Revision history | 16 |

1 Pin configuration

Figure 1. Pin connections

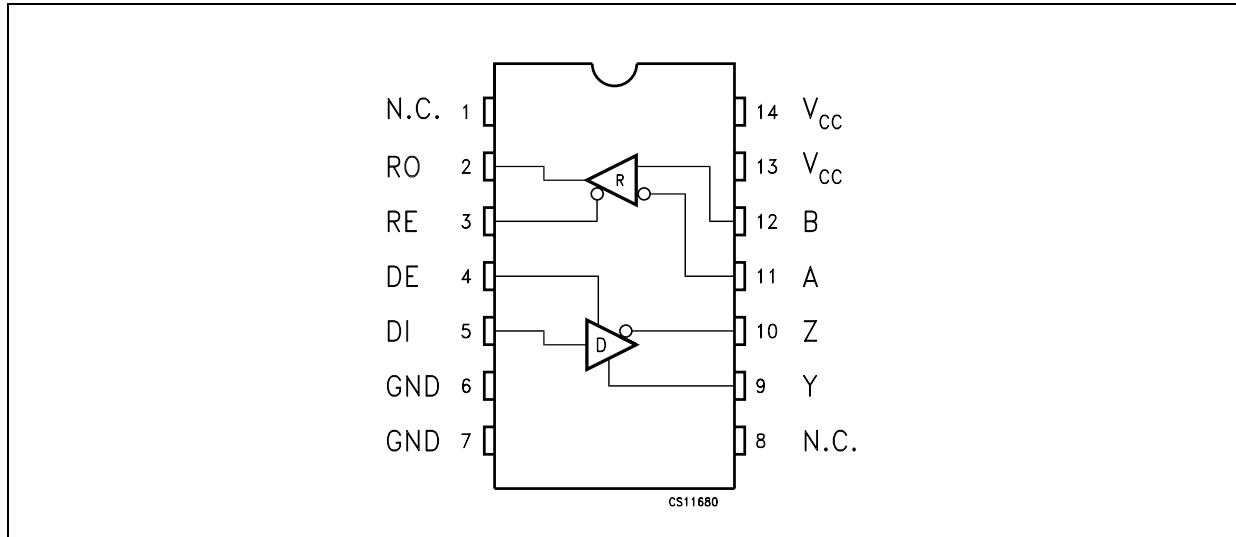

Table 1. Pin description

| Pin n° | Symbol | Name and function |
|--------|-----------------|------------------------------|
| 1 | NC | Not connected |
| 2 | RO | Receiver output. |
| 3 | RE | Receiver output enable |
| 4 | DE | Driver output enable |
| 5 | DI | Inverting driver input |
| 6 | GND | Ground |
| 7 | GND | Ground |
| 8 | NC | Not connected |
| 9 | Y | Non-inverting driver output |
| 10 | Z | Inverting driver output |
| 11 | A | Inverting receiver input |
| 12 | B | Non-inverting receiver input |
| 13 | V _{CC} | Supply voltage |
| 14 | V _{CC} | Supply voltage |

2 Truth tables

Table 2. Truth table (driver)

| Inputs | | Outputs | |
|--------|----|---------|---|
| DI | DE | Y | Z |
| L | H | L | H |
| H | H | H | L |
| X | L | Z | Z |

Note: X = Don't care; Z = High impedance

Table 3. Truth table (receiver)

| Inputs | | Outputs |
|---------------------------|----|---------|
| A-B | RE | RO |
| $\geq -0.2V$ | L | H |
| between $-0.2V$ to $0.2V$ | L | ? |
| $\leq -0.2V$ | L | L |
| OPEN | L | H |
| X | H | Z |

Note: ?=Irrelevant; X = Don't care; Z = High impedance

3 Maximum ratings

Table 4. Absolute maximum ratings

| Symbol | Parameter | Value | Unit |
|------------|-------------------------|----------------------------|------|
| V_{CC} | Supply voltage | 7 | V |
| V_{DI} | Driver input voltage | -0.5 to 7 | V |
| V_Y, V_Z | Driver output voltage | -7.5 to 12.5 | V |
| V_A, V_B | Receiver input voltage | -7.5 to 12.5 | V |
| V_{RO} | Receiver output voltage | -0.3 to ($V_{CC} + 0.3$) | V |
| ESD | Human body model | 3.5 | KV |

Note: Absolute maximum ratings are those values beyond which damage to the device may occur. Functional operation under these condition is not implied.

4 Electrical characteristics

Table 5. Electrical characteristics

($V_{CC} = 4.5V$ to $5.5V$, $T_A = -40$ to $85^\circ C$, unless otherwise specified. Typical values are referred to $T_A=25^\circ C$)

| Symbol | Parameter | Min. | Typ. | Max. | Unit |
|--------------|---------------------------|------|------|------|------|
| I_{SUPPLY} | No load supply current | | 2 | 5 | mA |
| C_{IN} | Input capacitance | | 1.8 | | pF |
| C_{YZ} | Driver output capacitance | | 1.2 | | pF |
| C_{OUT} | Output capacitance | | 2.3 | | pF |

Table 6. Transmitter electrical characteristics

($V_{CC} = 4.5V$ to $5.5V$, $T_A = -40$ to $85^\circ C$, unless otherwise specified. Typical values are referred to $T_A=25^\circ C$)

| Symbol | Parameter | Test conditions | Min. | Typ. | Max. | Unit |
|-----------------|---|--|----------|------|-----------|---------|
| V_{OD1} | Differential drive output (no load) | | | | V_{CC} | V |
| V_{OD2} | Differential drive output (with load) | $R_L = 54\Omega$ (RS-422) (<i>Figure 1.</i>) | 1.5 | 2.6 | 5 | V |
| V_{OD3} | Differential drive output (with load) | $R_L = 100\Omega$ (RS-422) (<i>Figure 1.</i>) | 2 | 3 | | V |
| ΔV_{OD} | Change in magnitude of driver differential output voltage for complementary output states | $R_L = 54\Omega$ or 100Ω (<i>Figure 1.</i>) | | 0 | 0.2 | V |
| V_{OC} | Driver common mode output voltage | $R_L = 54\Omega$ (<i>Figure 1.</i>) | 1 | | 3 | V |
| ΔV_{OC} | Change in magnitude of driver common mode output voltage | $R_L = 54\Omega$ (<i>Figure 1.</i>) | | 0 | 0.2 | V |
| I_{OFF} | Power off output current | $V_{CC} = 0V$, $V_O = -7V$ to $12V$ | | | ± 100 | μA |
| I_{OSD} | Driver short circuit output current | $V_O = -7V$ to $12V$ | ± 35 | | ± 250 | mA |
| V_{IL} | Input logic threshold low | | | | 0.8 | V |
| V_{IH} | Input logic threshold high | | 2 | | | V |

Table 7. Receiver electrical characteristics

($V_{CC} = 4.5V$ to $5.5V$, $T_A = -40$ to $85^\circ C$, unless otherwise specified. Typical values are referred to $T_A=25^\circ C$)

| Symbol | Parameter | Test Conditions | Min. | Typ. | Max. | Unit | |
|-----------------|---|---|--------------|------|-------|------------|----|
| I_{IN} | Input current (A, B) | Other input = 0V $V_{CC} = 0$ or $5.25V$ | $V_{IN}=12V$ | | 0.5 | 1 | mA |
| | | | $V_{IN}=-7V$ | | -0.35 | -0.8 | |
| V_{TH} | Receiver differential threshold voltage | $V_{CM} = -7V$ to $12V$ | -0.2 | | 0.2 | V | |
| ΔV_{TH} | Receiver input hysteresis | $V_{CM} = 0V$ | | 70 | | mV | |
| V_{OH} | Receiver output high voltage | $I_{OUT} = -8mA$, $V_{ID} = 200mV$ | 3.5 | 4.7 | | V | |
| V_{OL} | Receiver output low voltage | $I_{OUT} = 8mA$, $V_{ID} = -200mV$ | | 0.3 | 0.5 | V | |
| R_{RIN} | Receiver input resistance | $V_{CM} = -7V$ to $12V$ | 12 | 24 | | K Ω | |

Table 8. Driver switching characteristics

($V_{CC} = 4.5V$ to $5.5V$, $T_A = -40$ to $85^\circ C$, unless otherwise specified. Typical values are referred to $T_A=25^\circ C$)

| Symbol | Parameter | Test Conditions | Min. | Typ. | Max. | Unit |
|------------------------|-----------------------------------|---|------|------|------|------|
| D_R | Maximum data rate | Jitter <5% | 25 | 50 | | Mbps |
| t_{PLH} t_{PHL} | Propagation delay input to output | $R_L = 54\Omega$, $C_{L1}=C_{L2}=50pF$, (Figure 1.) | | 10 | 16 | ns |
| t_{SKEW} | Differential output delay skew | $R_L = 54\Omega$, $C_{L1}=C_{L2}=50pF$, (Figure 1.) | | 1 | 3 | ns |
| t_{TLH} t_{THL} | Rise or fall differential time | $R_L = 54\Omega$, $C_{L1}=C_{L2}=50pF$, (Figure 1.) | | 8 | 12 | ns |
| t_{PZL} | Output enable time | $C_L = 50pF$, S1 Closed | | 14 | 25 | ns |
| t_{PZH} | Output enable time | $C_L = 50pF$, S2 Closed | | 14 | 25 | ns |
| t_{PHZ} | Output disable time | $C_L = 15pF$, S2 Closed | | 10 | 25 | ns |
| t_{PLZ} | Output disable time | $C_L = 15pF$, S1 Closed | | 16 | 25 | ns |

Table 9. Receiver switching characteristics

($V_{CC} = 4.5V$ to $5.5V$, $T_A = -40$ to $85^\circ C$, unless otherwise specified. Typical values are referred to $T_A=25^\circ C$)

| Symbol | Parameter | Test Conditions | Min. | Typ. | Max. | Unit |
|------------------------|--|---------------------------------------|------|------|------|------|
| t_{PLH} t_{PHL} | Propagation delay input to output | $C_L = 15pF$, (Figure 2., Figure 4.) | | 19 | 30 | ns |
| t_{SKD} | $ t_{PLH} - t_{PHL} $ Receiver output skew | $C_L = 15pF$, (Figure 2., Figure 4.) | | 1 | 3 | ns |
| t_{TLH} t_{THL} | Rise or fall time | $C_L = 15pF$, (Figure 2., Figure 4.) | | 6 | | ns |
| t_{PZL} | Output enable time | $C_{RL} = 15pF$, S1 Closed | | 6 | 12 | ns |
| t_{PZH} | Output enable time | $C_{RL} = 15pF$, S2 Closed | | 7 | 12 | ns |
| t_{PHZ} | Output disable time | $C_{RL} = 15pF$, S2 Closed | | 6 | 12 | ns |
| t_{PLZ} | Output disable time | $C_{RL} = 15pF$, S1 Closed | | 6 | 12 | ns |

5 Test circuit and typical characteristics

Figure 2. Driver DC test load

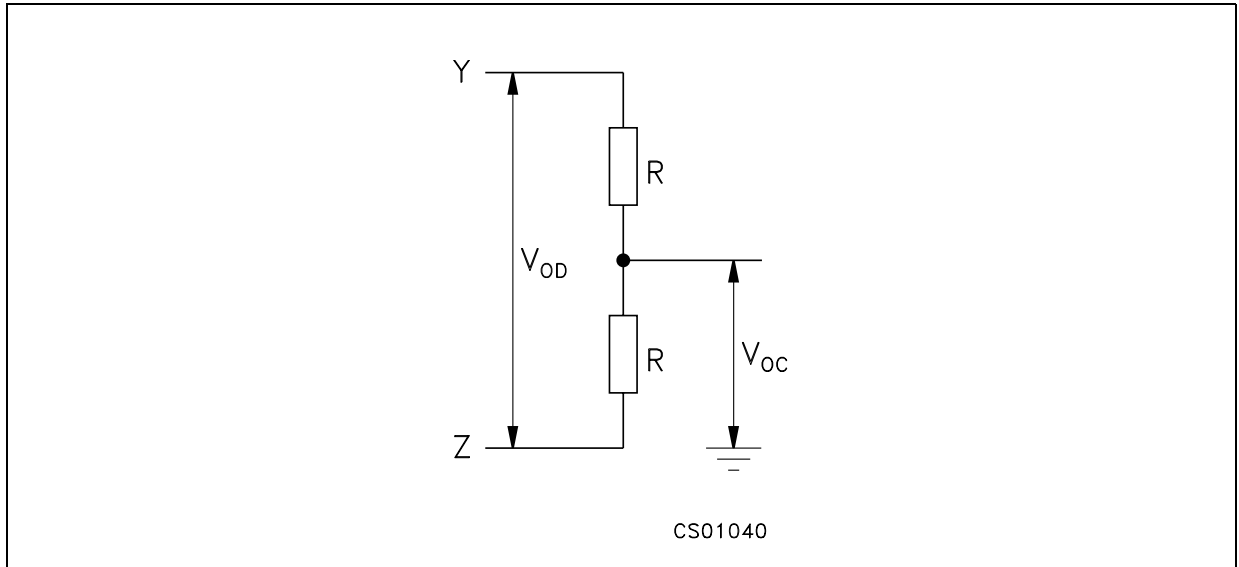

Figure 3. Receiver timing test load

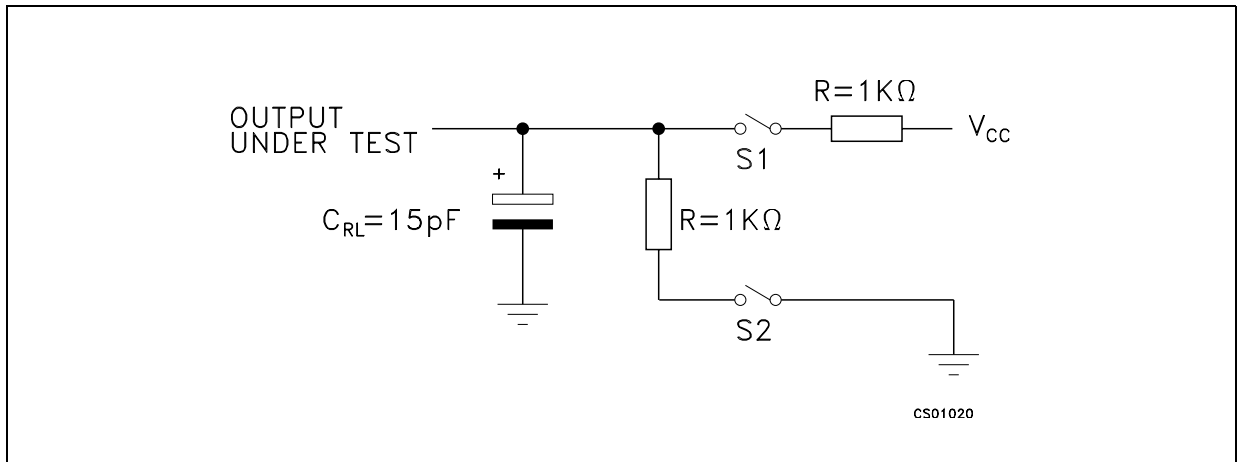

Figure 4. Driver/receiver timing test circuit

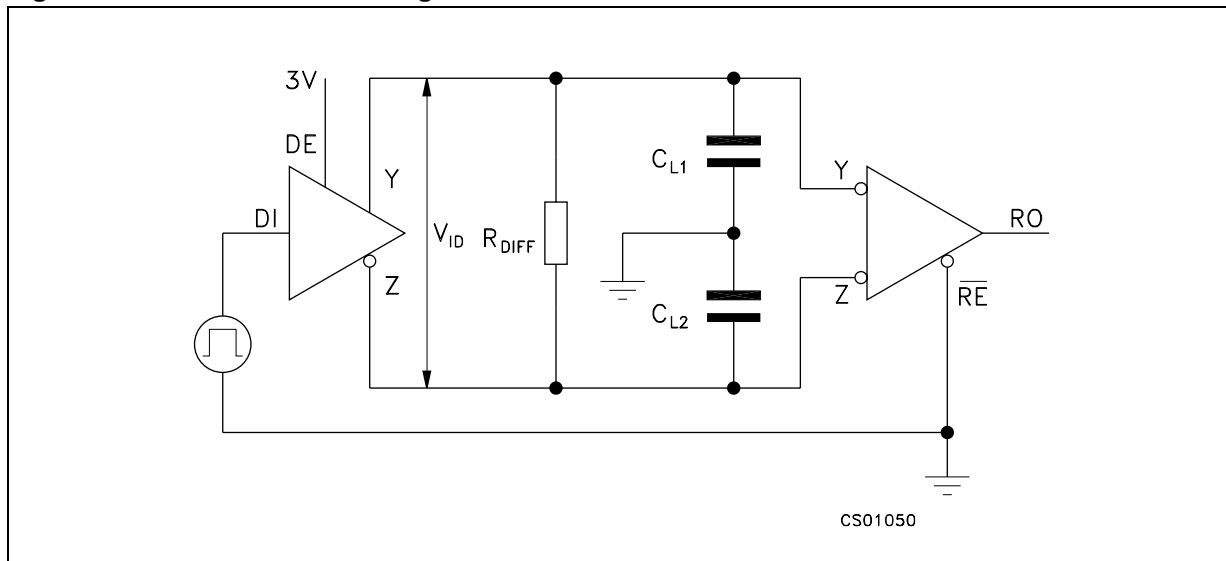

Figure 5. Driver timing test load

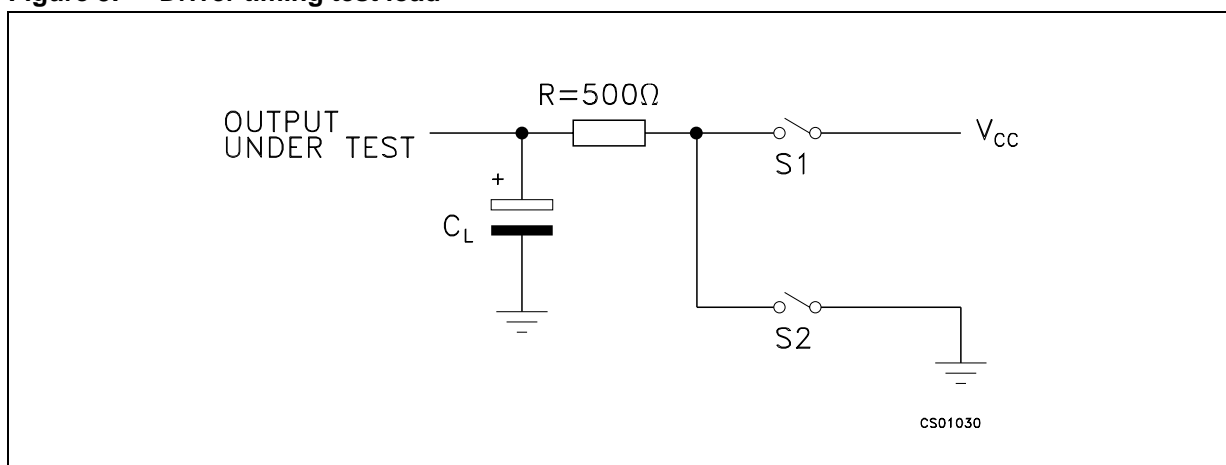

Figure 6. Driver propagation delay

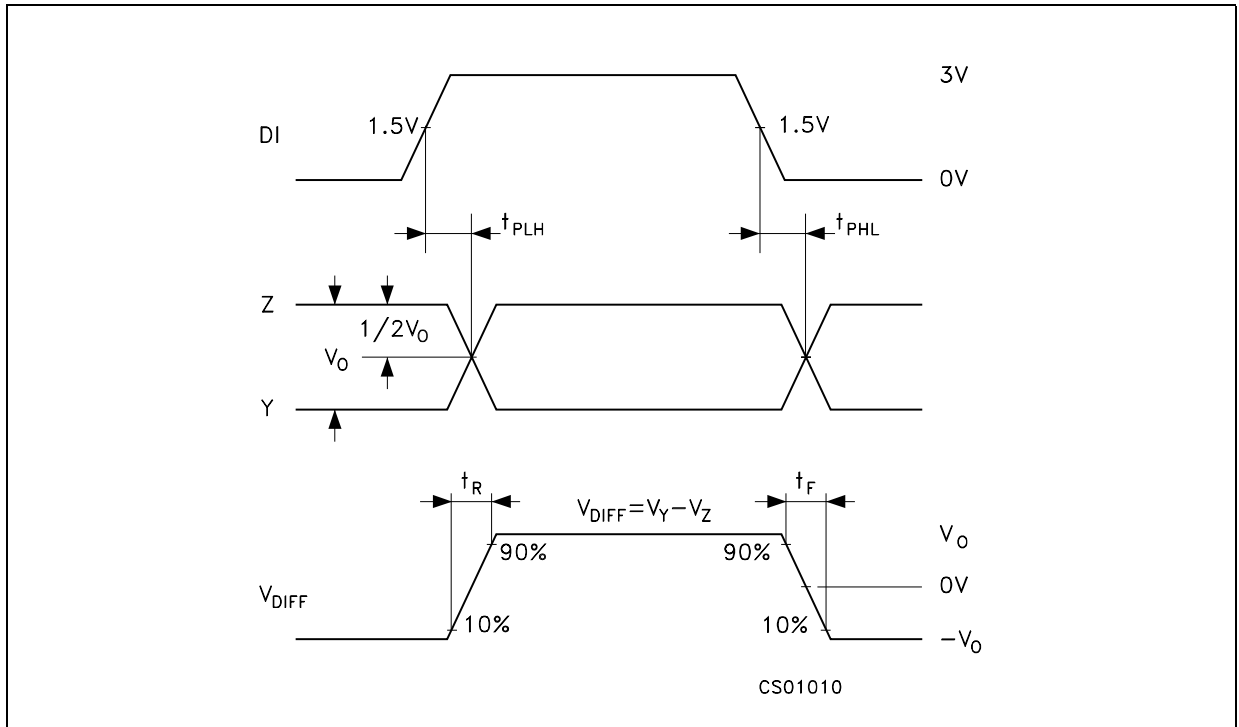

Figure 7. Receiver propagation delay

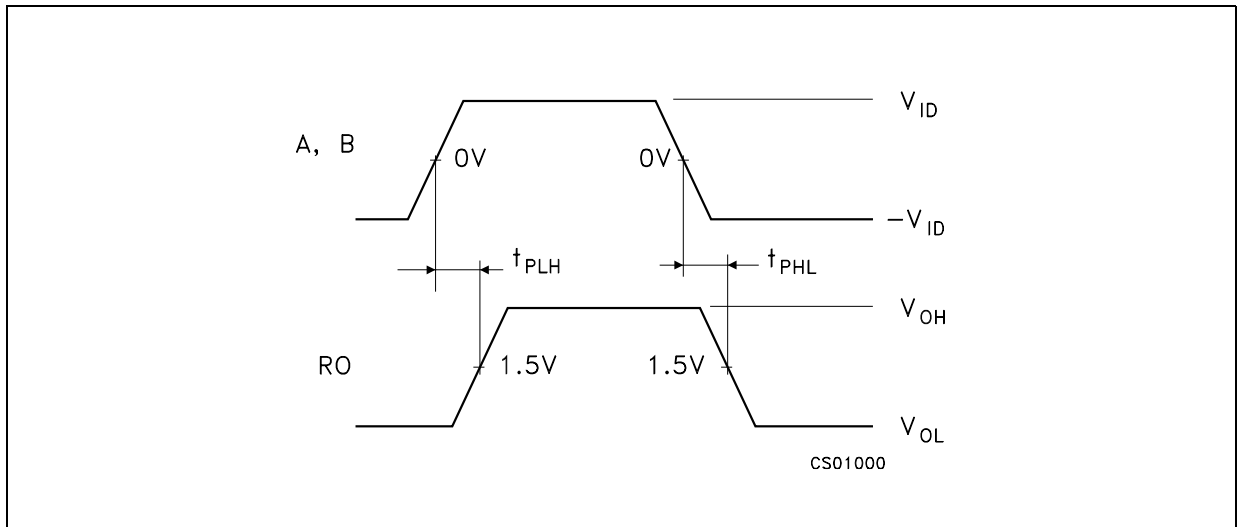

Figure 8. Receiver output current vs. output low voltage (output low)

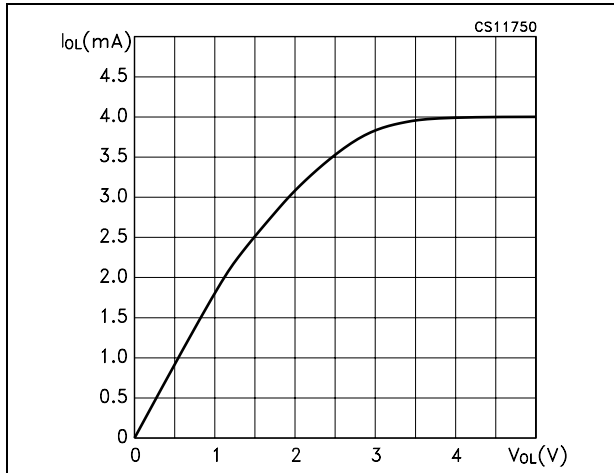

Figure 9. Receiver output current vs. output high voltage (output high)

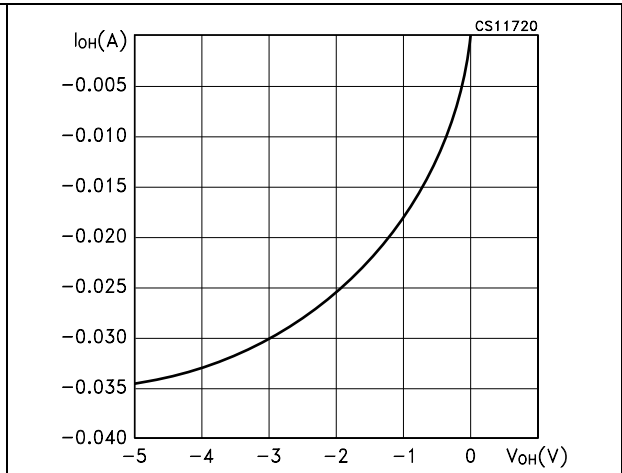

Figure 10. Driver diff. output voltage vs common mode voltage (diff. output low)

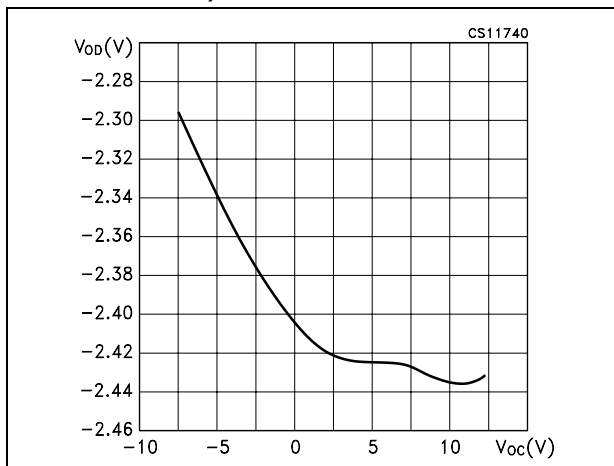

Figure 11. Driver diff. output voltage vs common mode voltage (diff. output high)

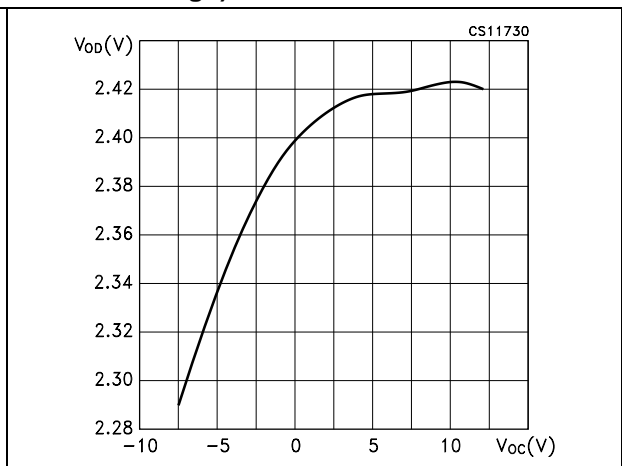

Figure 12. Driver short circuit current vs line voltage (output high)

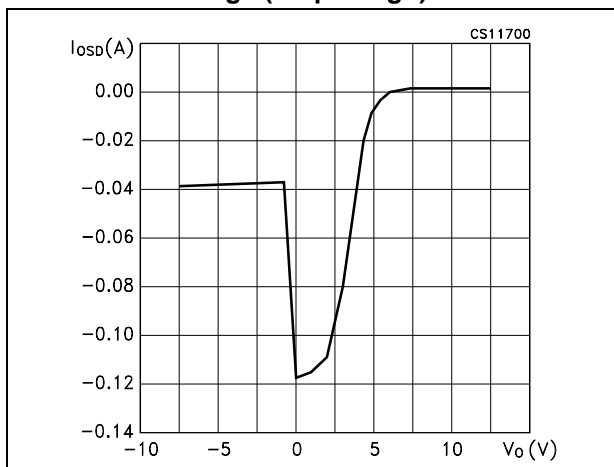

Figure 13. Receiver high level output voltage vs. temperature

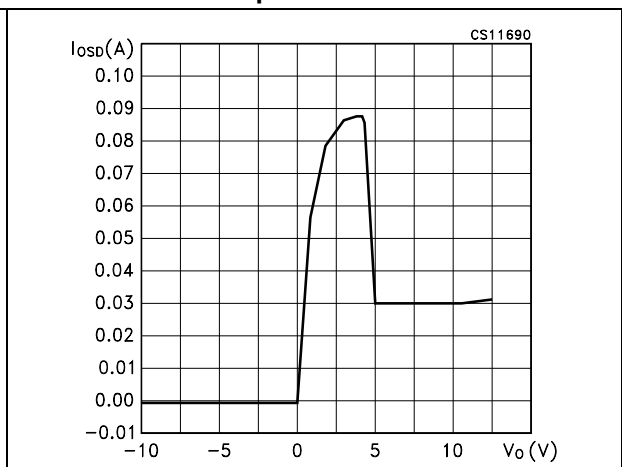
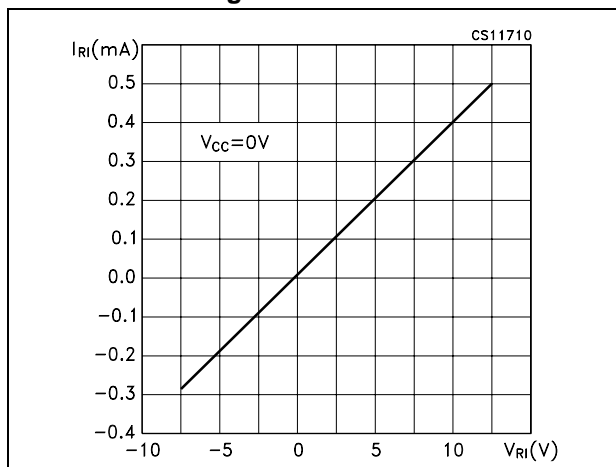

Figure 14. Receiver input current vs input voltage



6 Package mechanical data

In order to meet environmental requirements, ST offers these devices in ECOPACK® packages. These packages have a Lead-free second level interconnect. The category of second level interconnect is marked on the package and on the inner box label, in compliance with JEDEC Standard JESD97. The maximum ratings related to soldering conditions are also marked on the inner box label. ECOPACK is an ST trademark. ECOPACK specifications are available at: www.st.com

Plastic DIP-14 MECHANICAL DATA

| DIM. | mm. | | | inch | | |
|------|------|-------|------|-------|-------|-------|
| | MIN. | TYP | MAX. | MIN. | TYP. | MAX. |
| a1 | 0.51 | | | 0.020 | | |
| B | 1.39 | | 1.65 | 0.055 | | 0.065 |
| b | | 0.5 | | | 0.020 | |
| b1 | | 0.25 | | | 0.010 | |
| D | | | 20 | | | 0.787 |
| E | | 8.5 | | | 0.335 | |
| e | | 2.54 | | | 0.100 | |
| e3 | | 15.24 | | | 0.600 | |
| F | | | 7.1 | | | 0.280 |
| I | | | 5.1 | | | 0.201 |
| L | | 3.3 | | | 0.130 | |
| Z | 1.27 | | 2.54 | 0.050 | | 0.100 |

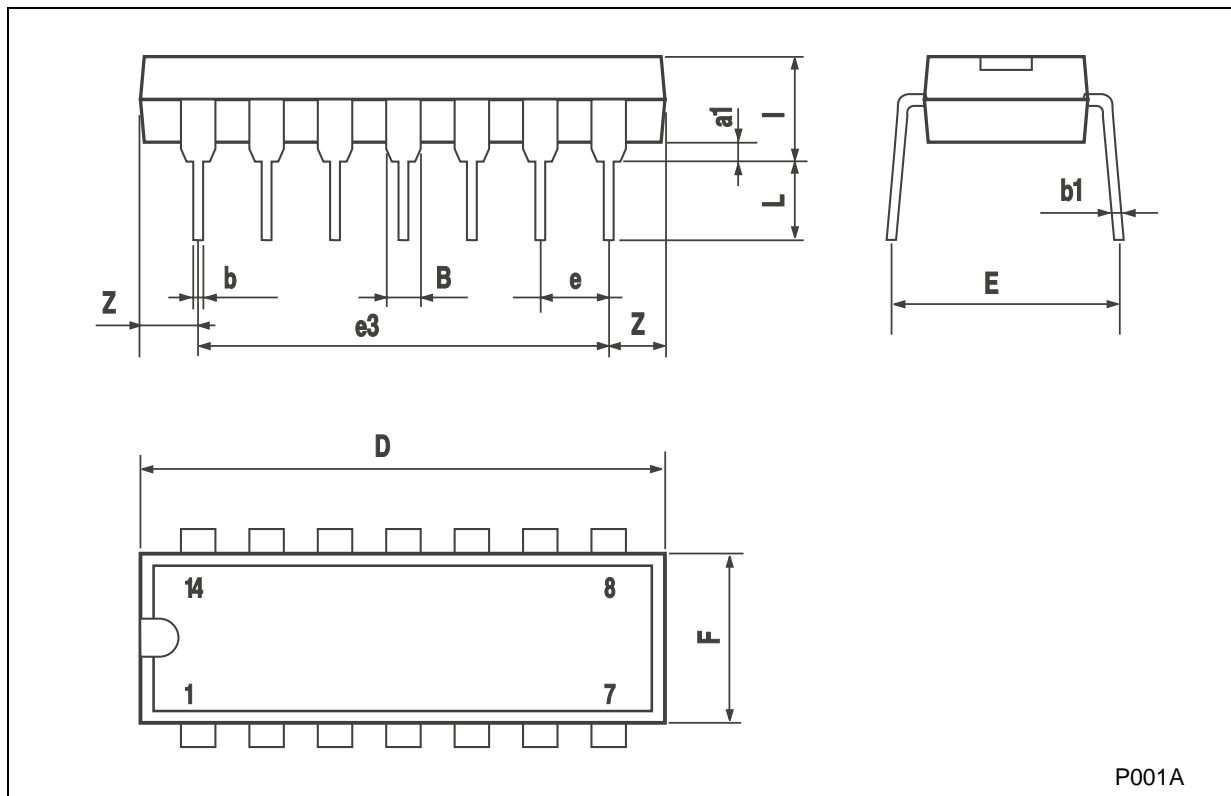

7 Revision history

Table 10. Revision history

| Date | Revision | Changes |
|-------------|----------|--|
| 10-May-2005 | 3 | Mistake on Figure 1. |
| 04-Jul-2005 | 4 | Mistake on Figure 1 and Table 1 (Pin 13). |
| 28-Apr-2006 | 5 | Order codes has been updated and new template. |

Please Read Carefully:

Information in this document is provided solely in connection with ST products. STMicroelectronics NV and its subsidiaries ("ST") reserve the right to make changes, corrections, modifications or improvements, to this document, and the products and services described herein at any time, without notice.

All ST products are sold pursuant to ST's terms and conditions of sale.

Purchasers are solely responsible for the choice, selection and use of the ST products and services described herein, and ST assumes no liability whatsoever relating to the choice, selection or use of the ST products and services described herein.

No license, express or implied, by estoppel or otherwise, to any intellectual property rights is granted under this document. If any part of this document refers to any third party products or services it shall not be deemed a license grant by ST for the use of such third party products or services, or any intellectual property contained therein or considered as a warranty covering the use in any manner whatsoever of such third party products or services or any intellectual property contained therein.

UNLESS OTHERWISE SET FORTH IN ST'S TERMS AND CONDITIONS OF SALE ST DISCLAIMS ANY EXPRESS OR IMPLIED WARRANTY WITH RESPECT TO THE USE AND/OR SALE OF ST PRODUCTS INCLUDING WITHOUT LIMITATION IMPLIED WARRANTIES OF MERCHANTABILITY, FITNESS FOR A PARTICULAR PURPOSE (AND THEIR EQUIVALENTS UNDER THE LAWS OF ANY JURISDICTION), OR INFRINGEMENT OF ANY PATENT, COPYRIGHT OR OTHER INTELLECTUAL PROPERTY RIGHT.

UNLESS EXPRESSLY APPROVED IN WRITING BY AN AUTHORIZED REPRESENTATIVE OF ST, ST PRODUCTS ARE NOT DESIGNED, AUTHORIZED OR WARRANTED FOR USE IN MILITARY, AIR CRAFT, SPACE, LIFE SAVING, OR LIFE SUSTAINING APPLICATIONS, NOR IN PRODUCTS OR SYSTEMS, WHERE FAILURE OR MALFUNCTION MAY RESULT IN PERSONAL INJURY, DEATH, OR SEVERE PROPERTY OR ENVIRONMENTAL DAMAGE.

Resale of ST products with provisions different from the statements and/or technical features set forth in this document shall immediately void any warranty granted by ST for the ST product or service described herein and shall not create or extend in any manner whatsoever, any liability of ST.

ST and the ST logo are trademarks or registered trademarks of ST in various countries.

Information in this document supersedes and replaces all information previously supplied.

The ST logo is a registered trademark of STMicroelectronics. All other names are the property of their respective owners.

© 2006 STMicroelectronics - All rights reserved

STMicroelectronics group of companies

Australia - Belgium - Brazil - Canada - China - Czech Republic - Finland - France - Germany - Hong Kong - India - Israel - Italy - Japan - Malaysia - Malta - Morocco - Singapore - Spain - Sweden - Switzerland - United Kingdom - United States of America

www.st.com