



ST7FLCD1

8-bit MCU for LCD monitors with 60 KBytes Flash,
2 KBytes RAM, 2 DDC ports and infrared controller

Features

- 60 KBytes Flash program memory
- In-circuit debugging and programming
- In-application programming
- Data RAM: up to 2 KBytes (256 bytes stack, 2 x 256 bytes for DDCs)
- 8 MHz, up to 9 MHz internal clock frequency
- True bit manipulation
- Run and wait CPU modes
- Programmable watchdog for system reliability
- Protection against illegal opcode execution
- 2 DDC bus interfaces with:
 - DDC 2B protocol implemented in hardware
 - Programmable DDC CI modes
 - Enhanced DDC (EDDC) address decoding
 - HDCP encryption keys
- Fast I²C single master interface
- 8-bit timer with programmable pre-scaler, auto-reload and independent buzzer output
- 8-bit timer with external trigger
- 4-channel, 8-bit analog to digital converter
- 4 + 2 8-bit PWM digital to analog outputs with frequency adjustment
- Infrared controller (IFR)
- Up to 22 I/O lines in 28-pin package
- 2 lines programmable as interrupt inputs
- Master reset and low voltage detector (LVD) reset
- Complete development support on PC Windows
- Full software package (assembler, linker, C-compiler and source level debugger)



Description

The ST7FLCD1 is a microcontroller (MCU) from the ST7 family with dedicated peripherals for LCD monitor applications. The ST7FLCD1 is an industry standard 8-bit core that offers an enhanced instruction set. The 5V supplied processor runs with an external clock at 24 MHz (27 MHz maximum). Under software control, the MCU mode changes to Wait mode thus reducing power consumption. The enhanced instruction set and addressing modes offer real programming potential.

In addition to standard 8-bit data management, the MCU features also include true bit manipulation, 8x8 unsigned multiplication and indirect addressing modes.

The device gathers the on-chip oscillator, CPU, 60-Kbyte Flash, 2-KByte RAM, I/Os, two 8-bit timers, infrared preprocessor, 4-channel Analog-to-Digital Converter, 2 DDCs, I²C single master, watchdog, reset and six 8-bit PWM outputs for analog DC control of external functions.

Contents

1	General information	6
1.1	Reference documents	7
1.2	Pin description	8
1.3	External connections	9
1.4	Memory map	11
2	Central processing unit (CPU)	15
2.1	Main features	15
2.1.1	CPU registers	15
3	Reset	22
3.1	Low voltage detector and watchdog reset	22
3.2	Watchdog or illegal operating code access reset	23
3.3	External reset	23
3.4	Reset procedure	23
4	Interrupts	24
4.1	Software	24
4.2	External interrupts (ITA, ITB)	24
4.3	Peripheral interrupts	24
4.4	Processing	25
4.5	Register description	26
5	Flash program memory	28
5.1	Main features	28
5.2	Structure	28
5.3	Program memory read-out protection	28
5.4	ICP (in-circuit programming)	29
5.5	IAP (in-application programming)	30
5.6	Register description	31
5.7	Flash option bytes	31

6	Clocks and low power modes	32
6.1	Clock system	32
6.1.1	General description	32
6.1.2	Crystal oscillator mode	32
6.1.3	External clock mode	32
6.1.4	Clock signals	33
6.2	Power saving modes	33
6.2.1	HALT mode	33
6.2.2	WAIT mode	33
6.2.3	Exit from HALT and WAIT modes	33
6.2.4	Selected peripherals mode	35
7	I/O ports	36
7.1	Common functional description	37
7.2	Port A	38
7.3	Port B	40
7.4	Port C	42
7.5	Port D	43
7.6	Register description	44
8	PWM generator	46
8.1	Main features	46
8.2	Functional description	46
8.3	Register description	49
9	8-bit analog-to-digital converter (ADC)	52
9.1	Main features	52
9.2	Functional description	52
9.2.1	Characteristics	52
9.2.2	Procedure	53
9.3	Register description	54
10	I2C single-master bus interface	56
10.1	Main features	56
10.2	General description	56

10.3	Functional description (master mode)	58
10.4	Transfer sequencing	58
10.4.1	Master receiver	58
10.4.2	Master transmitter	58
10.5	Register description	60
11	Display data channel interfaces (DDC)	65
11.1	DDC interface features	65
11.1.1	Hardware DDC2B interface features	65
11.1.2	DDC/CI factory interface features	65
11.2	Signal description	67
11.2.1	Serial data (SDA)	67
11.2.2	Serial clock (SCL)	68
11.3	DDC standard	68
11.3.1	DDC2B interface	68
11.3.2	Mode description	69
11.4	DDC/CI factory alignment interface	72
11.4.1	I ² C modes	72
11.5	Transfer sequencing	74
11.6	Register description	75
12	Watchdog timer (WDG)	81
12.1	Main features	81
12.2	Main watchdog counter	81
12.3	Lock-up counter	82
12.4	Interrupts	82
12.5	Register description	83
13	8-bit timer (TIMA)	84
13.1	Main features	84
13.2	Functional description	84
13.3	Register description	85
14	8-bit timer with external trigger (TIMB)	87
14.1	Main features	87

14.2	Functional description	87
15	Infrared preprocessor (IFR)	90
15.1	Main features	90
15.2	Functional description	90
15.3	Register description	91
16	Registers	93
16.1	Register description	93
17	Electrical characteristics	96
17.1	Absolute maximum ratings	96
17.2	Power considerations	97
17.3	Thermal characteristics	97
17.4	AC/DC electrical characteristics	98
17.5	Power on/off electrical specifications	99
17.6	8-bit analog-to-digital converter	100
17.7	I ² C/DDC bus electrical specifications	100
17.8	I ² C/DDC bus timings	101
18	Package mechanical data	103
18.1	Lead-free packaging	104
19	Revision history	105

1 General information

Figure 1. ST7FLCD1 functional diagram

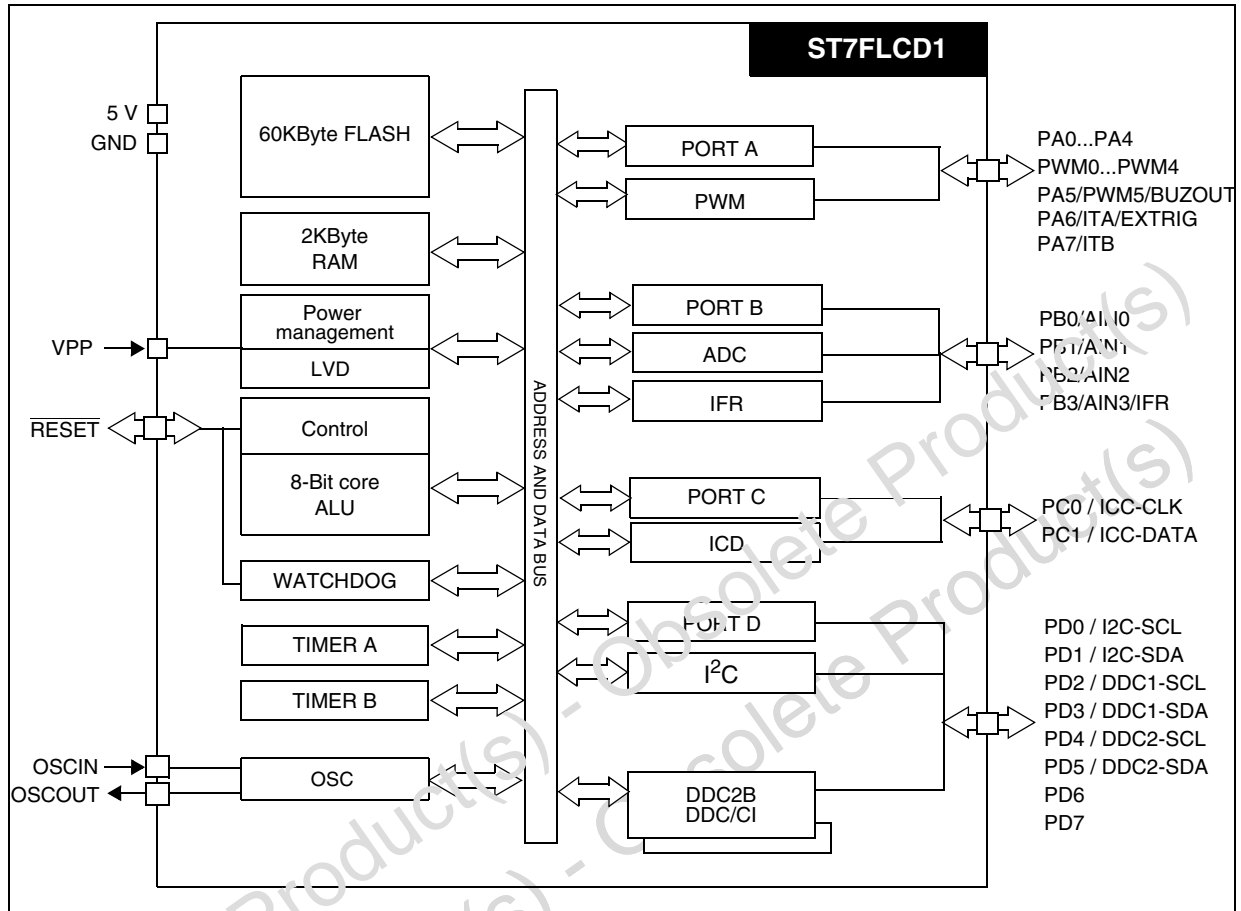

Table 1. Abbreviations

Abbreviations	Description
ADC	Analog-to-Digital Converter
ALU	Arithmetical and Logical Unit
CPU	Central Processing Unit
DDC	Display Data Channel
DMA	Direct Memory Access
I2C or IIC	Inter-Integrated Circuit bus
IAP	In-Application Programming
ICC	In-Circuit Communication
ICP	In-Circuit Programming
ICT	In-Circuit Testing
IFR	Infrared Controller

Table 1. Abbreviations (continued)

Abbreviations	Description
IT	Interrupt
LCD	Liquid Crystal Display
LVD	Low Voltage Detector
MCU	Microcontroller Unit
OSC	Oscillator
PWM	Pulse Width Modulator
TIM	Timer
WDG	Watchdog

1.1 Reference documents

Book: ST7 MCU Family Manual

CD: MCU on CD

Many libraries, software and applications notes are available.

Ask your STMicroelectronics sales office, your local support or search the company web site at www.st.com

1.2 Pin description

Figure 2. 28-pin small outline package (SO28) pinout

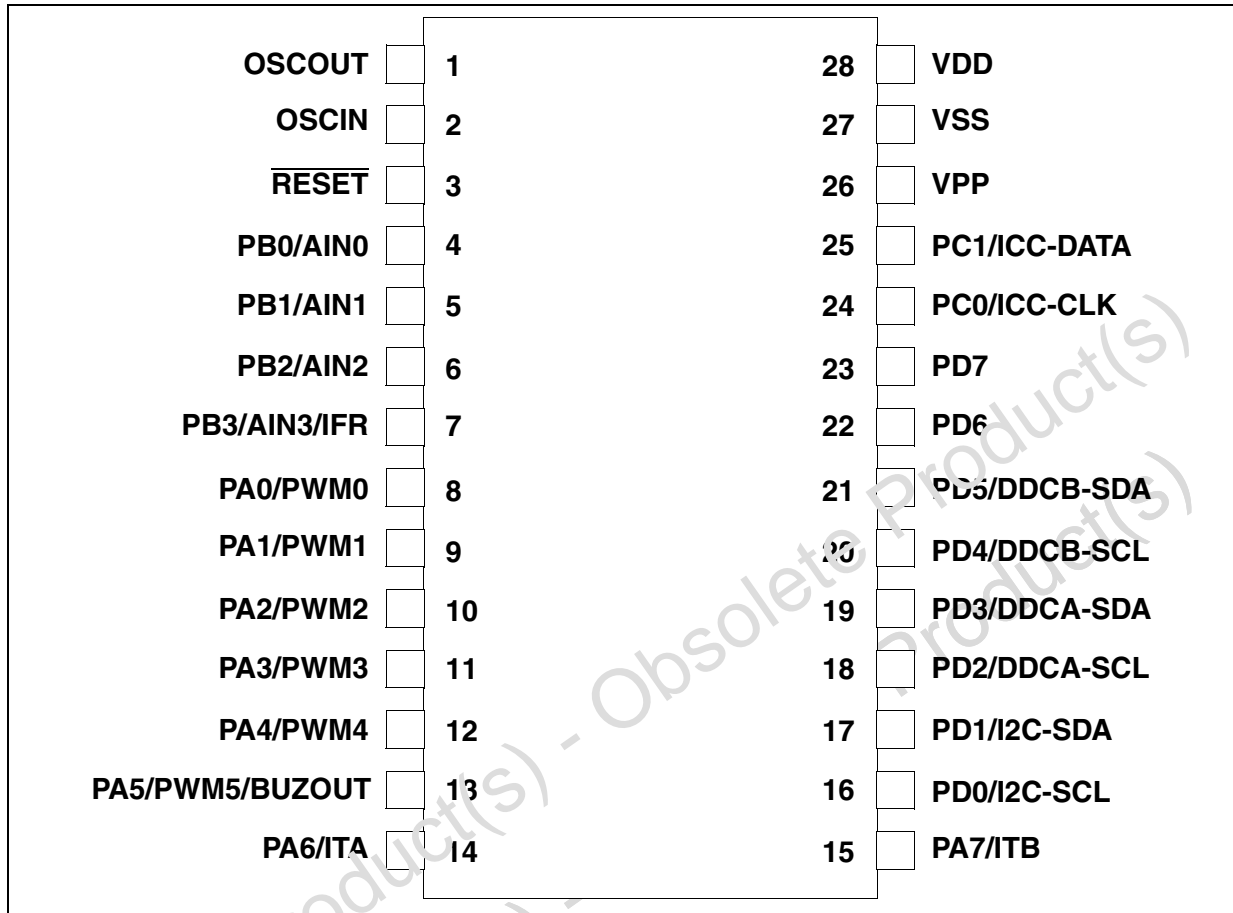

Table 2. 28-pin small outline package pin description

Pin	Pin name	Type	Description	Remark
1	OSCOUT	O	Oscillator Input	normal use at 24MHz
2	OSCIN	I	Oscillator Output	
3	RESET	I/O	Reset	
4	PB0/AIN0	I/O	Port B0 or ADC analog input 0	
5	PB1/AIN1	I/O	Port B1 or ADC analog input 1	
6	PB2/AIN2	I/O	Port B2 or ADC analog input 2	
7	PB3/AIN3/IFR	I/O	Port B3 or ADC analog input 3 or IFR input	
8	PA0/PWM0	I/O	Port A0 or PWM output 0	
9	PA1/PWM1	I/O	Port A1 or PWM output 1	
10	PA2/PWM2	I/O	Port A2 or PWM output 2	

Table 2. 28-pin small outline package pin description (continued)

Pin	Pin name	Type	Description	Remark
11	PA3/PWM3	I/O	Port A3 or PWM output 3	
12	PA4/PWM4	I/O	Port A4 or PWM output 4	
13	PA5/PWM5/BUZ OUT	I/O	Port A5 or PWM output 5 or Buzzer output	
14	PA6/ITA	I/O	Port A6 or interrupt input A	
15	PA7/ITB	I/O	Port A7 or interrupt input B	
16	PD0/I2C-SCL	I/O	Port D0 or I2C serial bus clock	
17	PD1/I2C-SDA	I/O	Port D1 or I2C serial bus data	
18	PD2/DDCA-SCL	I/O	Port D2 or DDCA serial bus clock	
19	PD3/DDCA-SDA	I/O	Port D3 or DDCA serial bus data	
20	PD4/DDCB-SCL	I/O	Port D4 or DDCB serial bus clock	
21	PD5/DDCB-SDA	I/O	Port D5 or DDCB serial bus data	
22	PD6	I/O	Port D6	
23	PD7	I/O	Port D7	
24	PC0/ICC-CLK	I/O	Port C0 or ICC clock	
25	PC1/ICC-DATA	I/O	Port C1 or ICC data	
26	VPP	PS	FLASH Programming supply voltage	normal op. mode: 0V ⁽¹⁾
27	VSS	PS	Ground	0V
28	VDD	PS	Power supply	5V

1. This pin must be connected to a 10k pull-down resistor, see [Section 1.3](#)

1.3 External connections

[Figure 3](#) shows the recommended external connections for the device.

The VPP pin is only used for programming or erasing the Flash memory array, and must be tied to a 10 K pull-down resistor for normal operation.

The 10 nF and 0.1 μ F decoupling capacitors on the power supply lines are a suggested EMC performance/cost tradeoff. The external RC reset network (including the mandatory 1K serial resistor) is intended to protect the device against parasitic resets, especially in noisy environments. Unused I/Os should be tied high to avoid any unnecessary power consumption on floating lines. An alternative solution is to program the unused ports as inputs with pull-up.

Figure 3. Recommended external connections

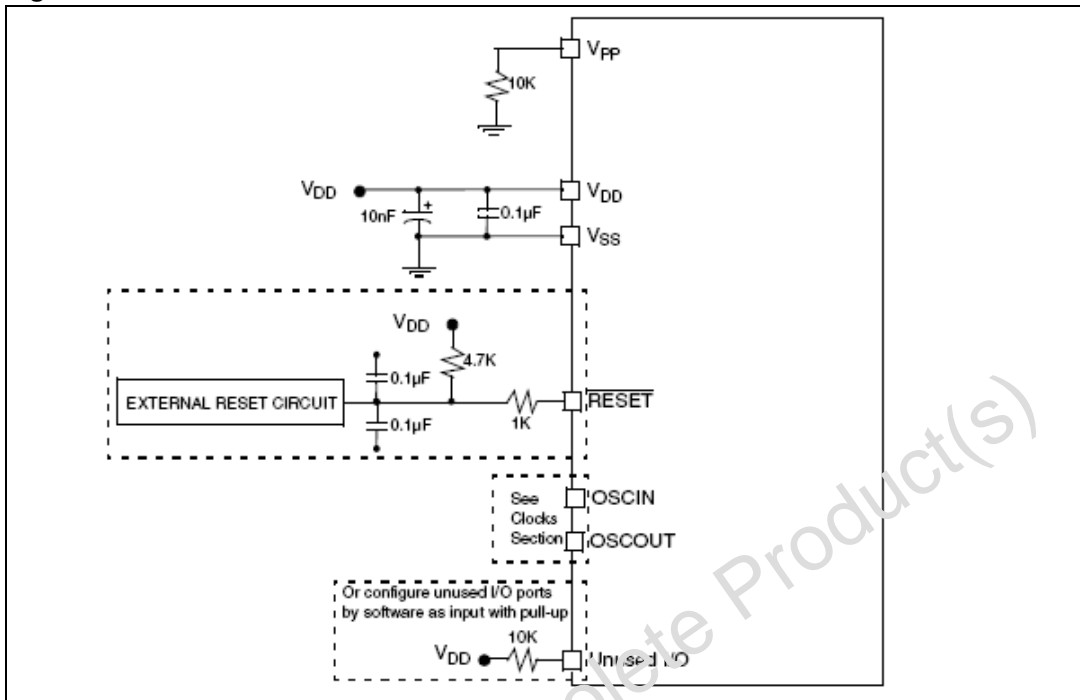

Obsolete Product(s) - Obsolete Product(s)
Obsolete Product(s) - Obsolete Product(s)

1.4 Memory map

Figure 4. Program memory map

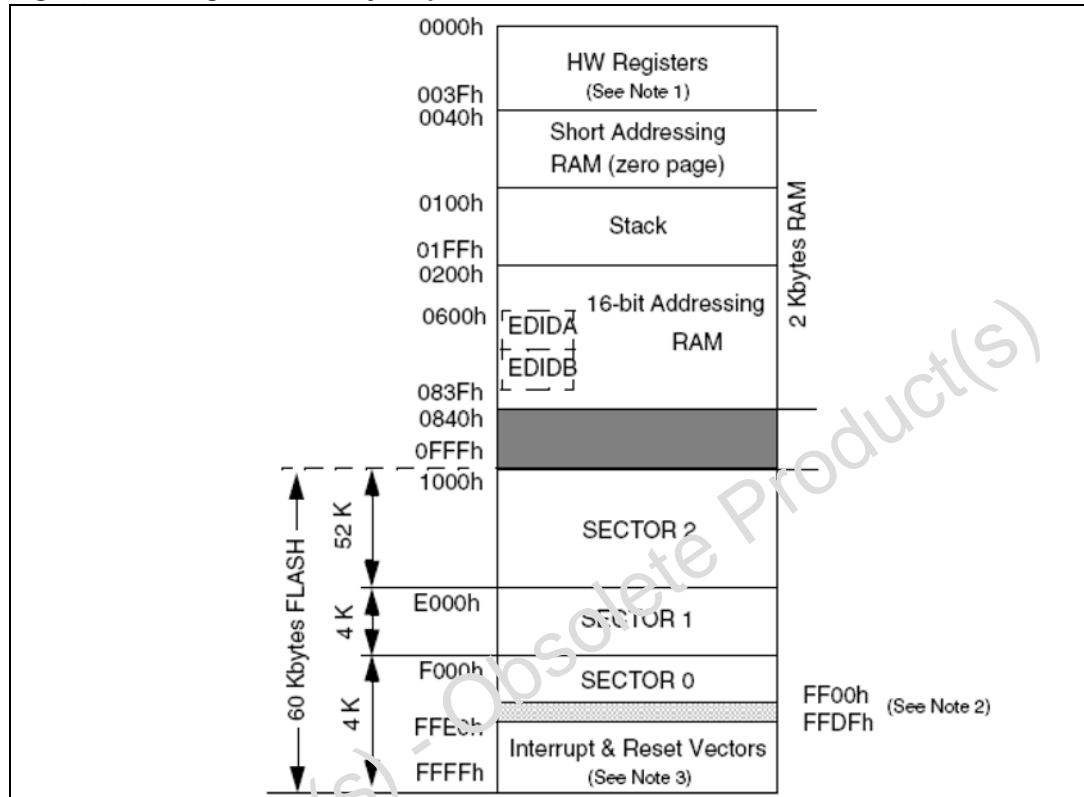

- Note: 1 Refer to [Table 3](#)
 2 Area FF00h to FFDFh is reserved in the event of ICD use.
 3 Refer to [Table 4](#)

Table 3. Hardware register memory map

Address	Block	Register Label	Register Name	Reset Status	Remarks
0000h	NAME	NAMER	Circuit name register	00h	Read
0001h	MISC	MISCR	Miscellaneous register	00h	R/W
0002h	Port A	PADR	Port A data register	00h	R/W
0003h		PADDR	Port A data direction register	00h	R/W
0004h	Port B	PBDR	Port B data register	00h	R/W
0005h		PBDDR	Port B data direction register	00h	R/W
0006h	Port C	PCDR	Port C data register	00h	R/W
0007h		PCDDR	Port C data direction register	00h	R/W
0008h	Port D	PDDR	Port D data register	00h	R/W
0009h		PDDDR	Port D data direction register	00h	R/W

Table 3. Hardware register memory map (continued)

Address	Block	Register Label	Register Name	Reset Status	Remarks	
000Ah	ADC	ADCDR	ADC data register	00h	R	
000Bh		ADCCSR	ADC control status register	00h	R/W	
000Ch	INTERRUPT	ITRFRE	External interrupt register	00h	R/W	
000Dh	TIMA	TIMCSRA	Timer control status register	00h	R/W	
000Eh		TIMCPRA	Timer counter preload register	00h	R/W	
000Fh	PWM	PWMDCR0	8 bits PWM0 duty cycle register	00h	R/W	
0010h		PWMDCR1	8 bits PWM1 duty cycle register	00h	R/W	
0011h		PWMDCR2	8 bits PWM2 duty cycle register	00h	R/W	
0012h		PWMDCR3	8 bits PWM3 duty cycle register	00h	R/W	
0013h		PWMCRA	PWM[0...3] control register	00h	R/W	
0014h		PWMARRA	PWM[0...3] auto reload register	FFh	R/W	
0015h		PWMDCR4	8 bits PWM4 duty cycle register	00h	R/W	
0016h		PWMDCR5	8 bits PWM5 duty cycle register	00h	R/W	
0017h		PWMCRB	PWM[4...5] control register	00h	R/W	
0018h		PWMARRB	PWM[4...5] auto reload register	FFh	R/W	
0019h		FLASH	FCSR	Flash control/status register	00h	R/W
001Ah	Reserved					
001Bh	WDG	WDGCR	Watchdog control 1 register	7Fh	R/W	
001Ch	I ² C	I2CCR	I2C control register	00h	R/W	
001Dh		I2CSR	I2C status register	00h	R	
001Eh		I2CCCR	I2C clock control register	00h	R/W	
001Fh		I2CDR	I2C data register	00h	R/W	
0020h	DDC A	DDCCRA	DDC control register	00h	R/W	
0021h		DDCSR1A	DDC status 1 register	00h	R	
0022h		DDCSR2A	DDC status 2 register	00h	R	
0023h		DDCOAR1A	DDC (7 Bits) slave address 1 register	00h	R/W	
0024h		DDCOAR2A	DDC (7 Bits) slave address 2 register	00h	R/W	
0025h		DDCDRA	DDC data register	00h	R/W	
0026h		RESERVED				
0027h		DDCDCRA	DDC2B control register	00h	R/W	
0028h		DDC B	DDCCRB	DDC control register	00h	R/W
0029h			DDCSR1B	DDC status 1 register	00h	R
002Ah	DDCSR2B		DDC status 2 register	00h	R	

Table 3. Hardware register memory map (continued)

Address	Block	Register Label	Register Name	Reset Status	Remarks
002Bh	DDC B	DDCOAR1B	DDC (7 Bits) slave address 1 register	00h	R/W
002Ch		DDCOAR2B	DDC (7 Bits) slave address 2 register	00h	R/W
002Dh		DDCDRB	DDC data register	00h	R/W
002Eh		RESERVED			
002Fh		DDCDCRB	DDC2B control register	00h	R/W
0030h	DM	DMCR	Debug control register	00h	R/W
0031h		DMSR	Debug status register	10h	R
0032h		DMBK1H	Debug breakpoint 1 MSB register	FFh	R/W
0033h		DMBK1L	Debug breakpoint 1 LSB register	FFh	R/W
0034h		DMBK2H	Debug breakpoint 2 MSB Register	FFh	R/W
0035h		DMBK2L	Debug Breakpoint 2 LSB register	FFh	R/W
0036h	IFR	IFRDR	Counter data register	00h	R
0037h		IFRCR	Control register	00h	R/W
0038h	TIMB	TIMCSR	Timer control status register	00h	R/W
0039h		TIMCPRB	Timer counter preload register	01h	R/W
003Ah	RESERVED				

Table 4. Interrupt vector map

Vector address	Description	Remarks
FFE0-FFE1h	Not Used	-
FFE2-FFE3h	Timer A Overflow interrupt vector	Internal interrupt
FFE4-FFE5h	Timer B Overflow Interrupt Vector	Internal interrupt
FFE6-FFE7h	Not Used	-
FFE8-FFE9h	I ² C interrupt vector	Internal interrupt
FFEA-FFEBh	ITB interrupt vector	External interrupt
FFEC-FFEDh	ITA interrupt vector	External interrupt
FFEE-FFEFh	IFR interrupt vector	Internal interrupt
FFF0-FFF1h	Not Used	
FFF2-FFF3h	DDC2B B interrupt vector	Internal interrupt
FFF4-FFF5h	DDC/CI B interrupt vector	Internal interrupt
FFF6-FFF7h	DDC2B A interrupt vector	Internal interrupt
FFF8-FFF9h	DDC/CI A interrupt vector	Internal interrupt
FFFA-FFFBh	Not Used	-

Table 4. Interrupt vector map (continued)

Vector address	Description	Remarks
FFFC-FFFDh	TRAP (software) interrupt vector	CPU interrupt
FFFE-FFFFh	RESET vector	-

Obsolete Product(s) - Obsolete Product(s)
Obsolete Product(s) - Obsolete Product(s)

2 Central processing unit (CPU)

This CPU has a full 8-bit architecture and contains six internal registers allowing efficient 8-bit data manipulation.

2.1 Main features

- Enable executing 63 basic instructions
- Fast 8-bit by 8-bit multiply
- 17 main addressing modes (with indirect addressing mode)
- Two 8-bit index registers
- 16-bit stack pointer
- 8 MHz CPU internal frequency (9 MHz max)
- Low power modes: WAIT and HALT
- Maskable hardware interrupts
- Non-maskable software interrupt

2.1.1 CPU registers

The 6 CPU registers shown in [Figure 5](#) are not present in the memory mapping and are accessed by specific instructions.

Accumulator (A)

The Accumulator is an 8-bit general purpose register that holds operands and results of arithmetic and logic calculations. It also manipulates data.

Index registers (X and Y)

In indexed addressing modes, these 8-bit registers are used to create either effective addresses or temporary storage areas for data manipulation. (The Cross-Assembler generates a previous instruction (PRE) to indicate that next instruction refers to Y register.)

The Y register is not affected by interrupt automatic procedures (not pushed to and popped from the stack).

Program counter (PC)

The program counter is a 16-bit register containing the address of next instruction the CPU executes. The program counter consists of two 8-bit registers:

- PCL (Program Counter Low which is the LSB)
- PCH (Program Counter High which is the MSB).

Figure 5. CPU registers

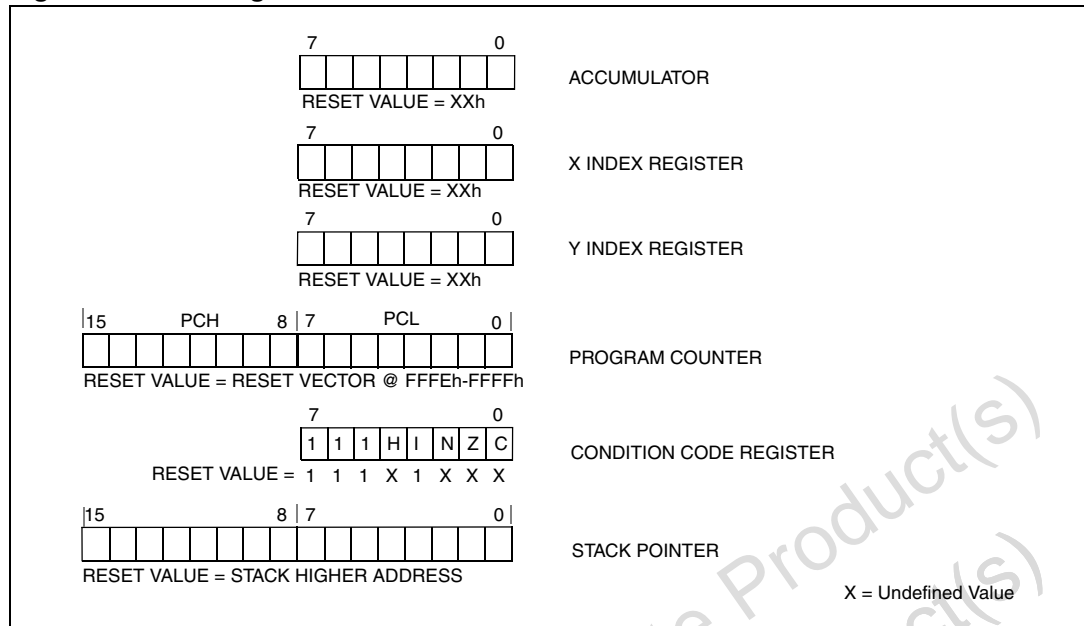

Condition code register (CC)

Read/Write

Reset Value: 111X1XXX



The 8-bit condition code register contains the interrupt mask and four flags resulting from the instruction just executed. This register can also be handled by the PUSH and POP instructions.

These bits can be individually tested and/or controlled by specific instructions.

Bit 4 = H half carry

This bit is set by hardware when a carry occurs between bits 3 and 4 of the ALU during an ADD or ADC instruction. It is reset by hardware during the same instructions.

0: No half carry has occurred.

1: A half carry has occurred.

This bit is tested using the JRH or JRNH instruction. The H bit is useful in BCD arithmetic subroutines.

Note: Instruction groups are defined in Table 6.

Bit 3 = I interrupt mask

This bit is set by hardware when entering in interrupt or by software to disable all interrupts except the TRAP software interrupt. This bit is cleared by software.

0: Interrupts are enabled.

1: Interrupts are disabled.

This bit is controlled by the RIM, SIM and IRET instructions and is tested by the JRM and JRNM instructions.

Interrupts requested while I is set are latched and processed when I is cleared. By default an interrupt routine is not interruptible as I bit is set by hardware when you enter it and reset by the IRET instruction at the end of interrupt routine. In case I bit is cleared by software during the interrupt routine, pending interrupts are serviced regardless of the priority level of the current interrupt routine.

Bit 2 = N negative

This bit is set and cleared by hardware. It is representative of the result sign of the last arithmetic, logical or data manipulation. It is a copy of the 7th bit of the result.

0: The last operation result is positive or null.

1: The last operation result is negative (i.e. the most significant bit is a logic 1)

This bit is accessed by the JRMI and JRPL instructions.

Bit 1 = Z zero

This bit is set and cleared by hardware. This bit indicates that the result of the last arithmetic, logical or data manipulation is zero.

0: The result of the last operation is different from zero.

1: The result of the last operation is zero.

This bit is accessed by the JREQ and JRNE test instructions.

Bit 0 = C carry/borrow

This bit is set and cleared by hardware and software. Informs if an overflow or underflow occurred during the last arithmetic operation.

0: No overflow or underflow has occurred.

1: An overflow or underflow has occurred.

This bit is driven by the SCF and RCF instructions and tested by the JRC and JRNC instructions. It is also affected by the “bit test and branch”, shift and rotate instructions.

Stack pointer (SP)

Read/Write

Reset Value: 01 FFh

15								8
0	0	0	0	0	0	0	1	
7								0
SP7	SP6	SP5	SP4	SP3	SP2	SP1	SP0	

The stack pointer is a 16-bit register always pointing to the next free location in the stack. The pointer value increments when data is taken from the stack, it decrements once data is transferred into the stack (see [Figure 6](#)).

Since the stack is 256 bytes deep, the most significant byte is forced by hardware. Following an MCU Reset, or after a Reset Stack Pointer instruction (RSP), the Stack Pointer contains its reset value (the SP7 to SP0 bits are set) which is the stack highest address.

The least significant byte of the Stack Pointer (called S) can be directly accessed by a LD instruction.

Note: When the lower limit is exceeded, the Stack Pointer wraps around stack upper limit, without indicating stack overflow. The previously stored information is then overwritten and therefore lost. Stack also wraps in case of underflow.

Stack is used to save return address during a subroutine call and CPU context during interrupt. You can directly manipulate the stack using PUSH and POP instructions. In case of interrupt, PCL is stored at the first location pointed to by the SP. Other registers are then stored in the next locations as shown in Figure 6.

When interrupt is received, the SP value decrements and the context is pushed to the stack. On return from interrupt, the SP value increments and the context is popped from the stack. A subroutine call and interrupt occupy two and five locations in the stack area respectively.

Figure 6. Stack manipulation example

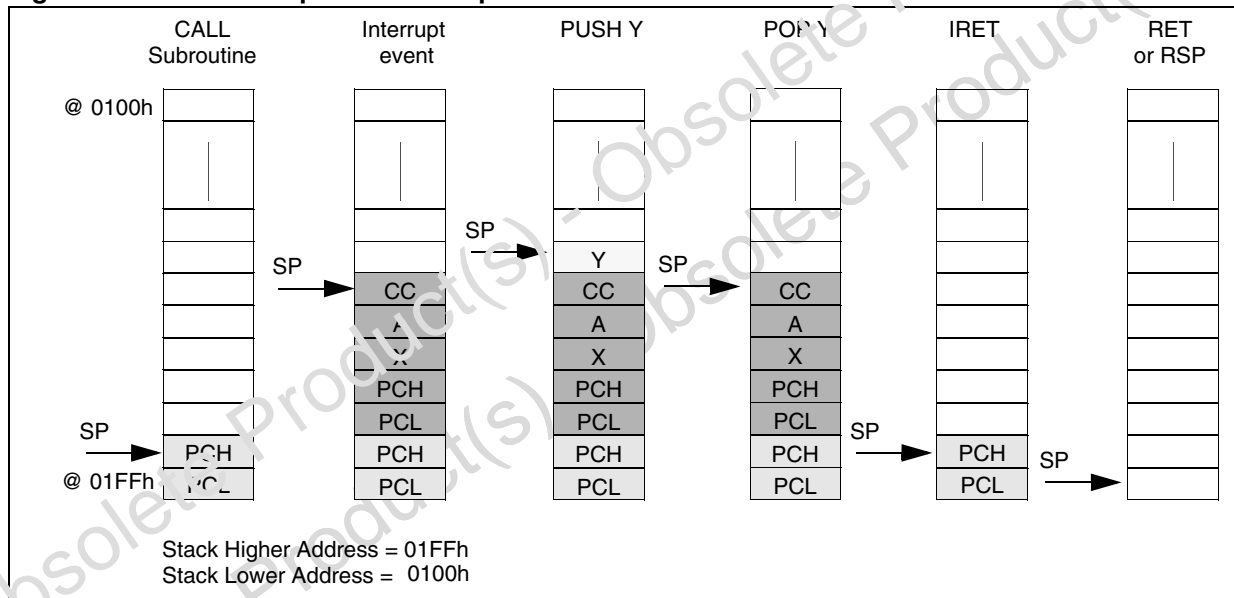

Table 5. Instruction set

	Bit 7	Bit 6	Bit 5	Bit 4	Bit 3	Bit 2	Bit 1	Bit 0
Load and transfer	LD	CLR						
Stack operation	PUSH	POP	RSP					
Increment/decrement	INC	DEC						
Compare and tests	CP	TNZ	BCP					
Logical operations	AND	OR	XOR	CPL	NEG			
Bit operations	BSET	BRES						

Table 5. Instruction set (continued)

	Bit 7	Bit 6	Bit 5	Bit 4	Bit 3	Bit 2	Bit 1	Bit 0
Conditional bit test and branch	BTJT	BTJF						
Arithmetic operations	ADC	ADD	SUB	SBC	MUL			
Shift and rotates	SLL	SRL	SRA	RLC	RRC	SWAP	SLA	
Unconditional jump or call	JRA	JRT	JRF	JP	CALL	CALLR	NOP	RET
Conditional branch	JRXX							
Interruption management	TRAP	WFI	HALT	IRET				
Code condition flag modification	SIM	RIM	SCF	RCF				

Table 6. Instruction groups

Mnemo	Description	Function/Example	Dst	Src	H	I	N	Z	C
ADC	Add with Carry	$A = A + M + C$	A	M	H		N	Z	C
ADD	Addition	$A = A + M$	A	M	H		N	Z	C
AND	Logical And	$A = A \cdot M$	A	M			N	Z	
BCP	Bit compare A, Memory	tst (A, M)	A	M			N	Z	
BRES	Bit Reset	bres Byte, #3	M						
BSET	Bit Set	bset Byte, #3	M						
BTJF	Jump if bit is false (0)	btjf Byte, #3, Jmp1	M						C
BTJT	Jump if bit is true (1)	btjt Byte, #3, Jmp1	M						C
CALL	Call subroutine								
CALLR	Call subroutine relative								
CLR	Clear		reg, M				0	1	
CP	Arithmetic Compare	tst(Reg - M)	reg	M			N	Z	C
CPL	One Complement	$A = FFH - A$	reg, M				N	Z	1
DEC	Decrement	dec Y	reg, M				N	Z	
HALT	Halt	reset when WDG active				0			
IRET	Interrupt routine return	Pop CC, A, X, PC			H	I	N	Z	C

Table 6. Instruction groups (continued)

Mnemo	Description	Function/Example	Dst	Src	H	I	N	Z	C
INC	Increment	inc X	reg, M				N	Z	
JP	Absolute Jump	jp [TBL.w]							
JRA	Jump relative always								
JRT	Jump relative								
JRF	Never jump	jrf *							
JRIH	Jump if ext. interrupt = 1								
JRIL	Jump if ext. interrupt = 0								
JRH	Jump if H = 1	H = 1 ?							
JRNH	Jump if H = 0	H = 0 ?							
JRM	Jump if I = 1	I = 1 ?							
JRNM	Jump if I = 0	I = 0 ?							
JRMI	Jump if N = 1 (minus)	N = 1 ?							
JRPL	Jump if N = 0 (plus)	N = 0 ?							
JREQ	Jump if Z = 1 (equal)	Z = 1 ?							
JRNE	Jump if Z = 0 (not equal)	Z = 0 ?							
JRC	Jump if C = 1	C = 1 ?							
JRNC	Jump if C = 0	C = 0 ?							
JRULT	Jump if C = 1	Unsigned <							
JRUGE	Jump if C = 0	Jmp if unsigned >=							
JRUGT	Jump if (C + Z = 0)	Unsigned >							
JRILE	Jump if (C + Z = 1)	Unsigned <=							
LD	Load	dst <= src	reg, M	M, reg			N	Z	
MUL	Multiply	X,A = X * A	A, X, Y	X, Y, A	0				0
NEG	Negate (2's compl)	neg \$10	reg, M				N	Z	C
NOP	No Operation								
OR	OR operation	A = A + M	A	M			N	Z	
POP	Pop from the Stack	pop reg pop CC	reg CC	M M					
					H	I	N	Z	C

Table 6. Instruction groups (continued)

Mnemo	Description	Function/Example	Dst	Src	H	I	N	Z	C
PUSH	Push onto the Stack	push Y	M	reg, CC					
RCF	Reset carry flag	$C = 0$							0
RET	Subroutine Return								
RIM	Enable Interrupts	$I = 0$				0			
RLC	Rotate left true C	$C \Leftarrow Dst \Leftarrow C$	reg, M				N	Z	C
RRC	Rotate right true C	$C \Rightarrow Dst \Rightarrow C$	reg, M				N	Z	C
RSP	Reset Stack Pointer	$S = \text{Max allowed}$							
SBC	Subtract with Carry	$A = A - M - C$	A	M			N	Z	C
SCF	Set carry flag	$C = 1$							1
SIM	Disable Interrupts	$I = 1$				1			
SLA	Shift left Arithmetic	$C \Leftarrow Dst \Leftarrow 0$	reg, M				N	Z	C
SLL	Shift left Logic	$C \Leftarrow Dst \Leftarrow 0$	reg, M				N	Z	C
SRL	Shift right Logic	$0 \Rightarrow Dst \Rightarrow C$	reg, M				0	Z	C
SRA	Shift right Arithmetic	$Dst7 \Rightarrow Dst \Rightarrow C$	reg, M				N	Z	C
SUB	Subtraction	$A = A - M$	A	M			N	Z	C
SWAP	SWAP nibbles	$Dst[7..4] \Leftrightarrow Dst[3..0]$	reg, M				N	Z	
TNZ	Test for Neg & Zero	tnz lbl1					N	Z	
TRAP	S/W trap	S/W interrupt				1			
WFI	Wait for Interrupt					0			
XOR	Exclusive OR	$A = A \text{ XOR } M$	A	M			N	Z	

3 Reset

The reset procedure provides an orderly software start-up or quits low power modes.

Three reset modes are provided:

1. Low voltage detector reset,
2. Watchdog or illegal operating code access reset,
3. External reset at the $\overline{\text{RESET}}$ pin.

At reset, the reset vector is fetched from FFFEh and FFFFh addresses and loaded into the PC (the program execution starting from this point).

An internal circuitry provides a 4096 CPU clock cycle delay as soon as that the oscillator becomes active.

3.1 Low voltage detector and watchdog reset

The low voltage detector circuitry generates a reset when:

V_{DD} is above V_{TRM} ,

V_{DD} is below V_{TRH} when V_{DD} is rising,

V_{DD} is below V_{TRL} when V_{DD} is falling ([Figure 7](#))

Figure 7. Low voltage detector

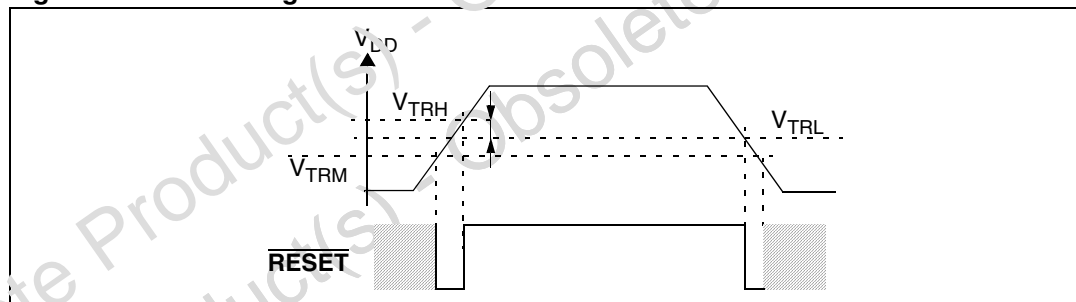

Typical hysteresis ($V_{TRH}-V_{TRL}$) of 250 mV

This circuitry is active only when V_{DD} is higher than V_{TRM} .

During low voltage detector Reset, the $\overline{\text{RESET}}$ pin is held low, thus permitting the MCU to reset other devices.

During a watchdog reset, the $\overline{\text{RESET}}$ pin is pulled low permitting the MCU to reset other devices as when low voltage ([Figure 8](#)). The reset cycle is pulled low during 500ns typically.

Figure 8. Reset generation diagram

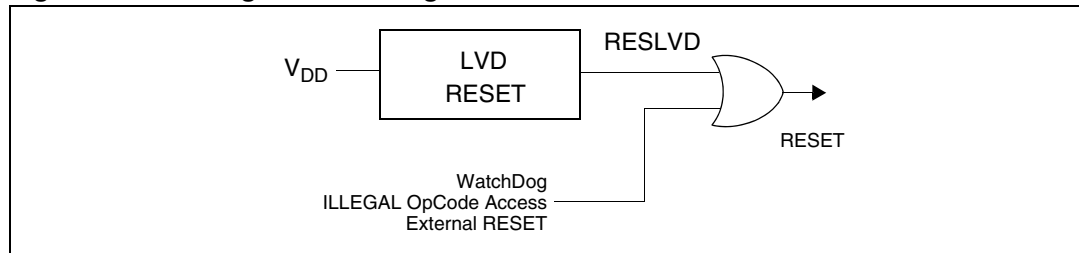

3.2 Watchdog or illegal operating code access reset

For more information regarding the watchdog, refer to [Section 12](#).

An illegal opcode reset occurs if the MCU attempts to read and execute a code that does not match a valid ST7 instruction.

3.3 External reset

The external reset is an active low input signal applied to $\overline{\text{RESET}}$ pin of MCU.

As shown in [Figure 9](#), $\overline{\text{RESET}}$ signal must remain low for a minimum of 1 μs .

Internal Schmitt trigger and filter provided at the $\overline{\text{RESET}}$ pin improve noise immunity.

3.4 Reset procedure

At power-up, the MCU follows the sequence described in [Figure 9](#).

Figure 9. Reset timing diagram

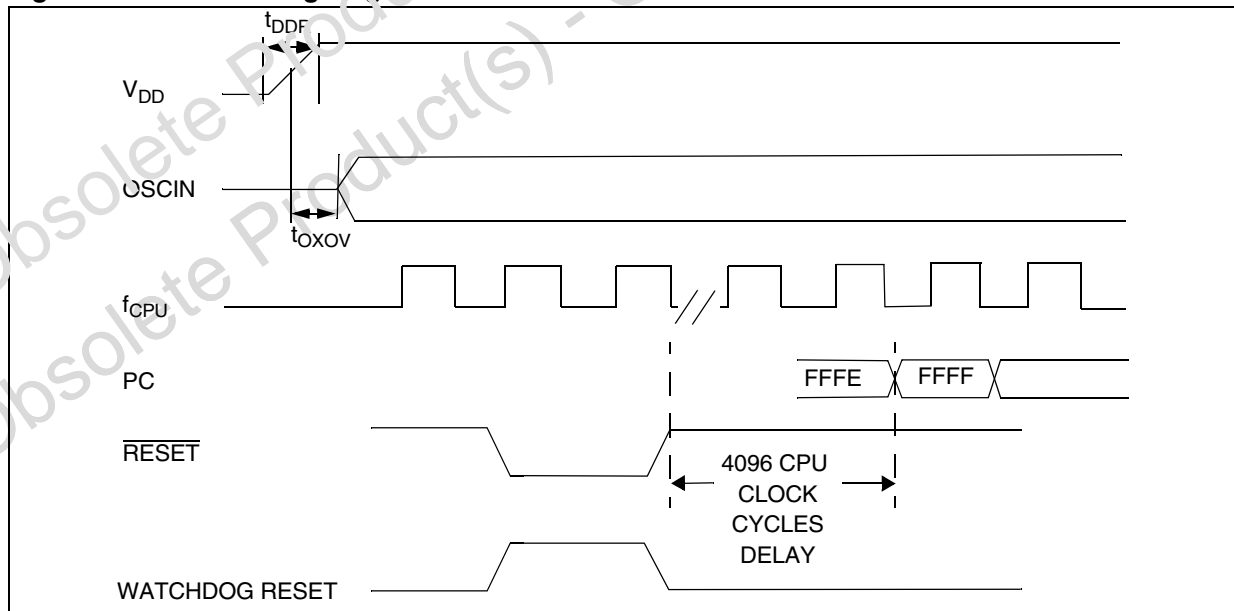

Note: Refer to Electrical Characteristics for values of t_{DDF} , t_{OXOV} , V_{TRH} , V_{TRL} and V_{TRM}

4 Interrupts

There are two different methods to interrupt the ST7:

1. Maskable hardware interrupts as listed in [Table 8](#)
2. Non-maskable software interrupt (TRAP).

The Interrupt processing flowchart is shown in [Figure 10](#).

Only enabled maskable interrupts are serviced. However, disabled interrupts are latched and processed. For an interrupt to be serviced, PC, X, A and CC registers are saved onto the stack, interrupt mask (I bit of the Condition Code Register) is set to prevent additional interrupts. Y register is not automatically saved.

The PC is then loaded with interrupt vector, the interrupt service routine runs (refer to [Table 8](#) for vector addresses) and ends with the IRET instruction. With this letter, registers contents are recovered from the stack and normal processing resumes

Note: I bit is then cleared providing that the corresponding bit stored in the stack is zero.

Though many interrupts can be run simultaneously, a priority order is defined (see [Table 8](#)). The $\overline{\text{RESET}}$ pin has the highest priority.

If I bit is set, only TRAP interrupt is enabled.

All interrupts allow the processor to exit WAIT low power mode.

4.1 Software

The software interrupt is the executable instruction TRAP. The interrupt is recognized when the TRAP instruction is executed, regardless of I bit state. When interrupt is recognized, it is serviced according to flowchart described in [Figure 10](#).

Note: During ICC communication the TRAP interrupt is reserved.

4.2 External interrupts (ITA, ITB)

The ITA (PA6), ITB (PA7) pins generate an interrupt when a falling or rising edge occurs on these pins. These interrupts are enabled with ITAITE, ITBITE bits respectively, in ITRFRE register, also providing that I bit from CC register is reset. Each external interrupt has an interrupt vector that uses ITRFRE register.

4.3 Peripheral interrupts

The various peripheral devices with interrupts include both Display Data Channels (DDC A and DDC B), the Infrared Controller (IFR), two 8-bit timers (Timer A and Timer B) and the I²C interface.

Different peripheral interrupt flags fetch an interrupt if the I bit from the CC register is reset and the corresponding Enable bit is set. If any of these conditions is not fulfilled, the interrupt is latched but not serviced, thus remaining pending.

4.4 Processing

Interrupt flags are located in the status register. The Enable bits are in the control register. When an enabled interrupt occurs, normal processing is suspended at the end of the current instruction execution. It is then serviced according to the flowchart from *Figure 10*.

The general sequence for clearing an interrupt is an access to the status register while the flag is set followed by a read or write of an associated register. Note that the clearing sequence resets the internal latch. A pending interrupt (i.e. waiting for being enabled) will therefore be lost if the clear sequence is executed.

Figure 10. Interrupt processing flowchart

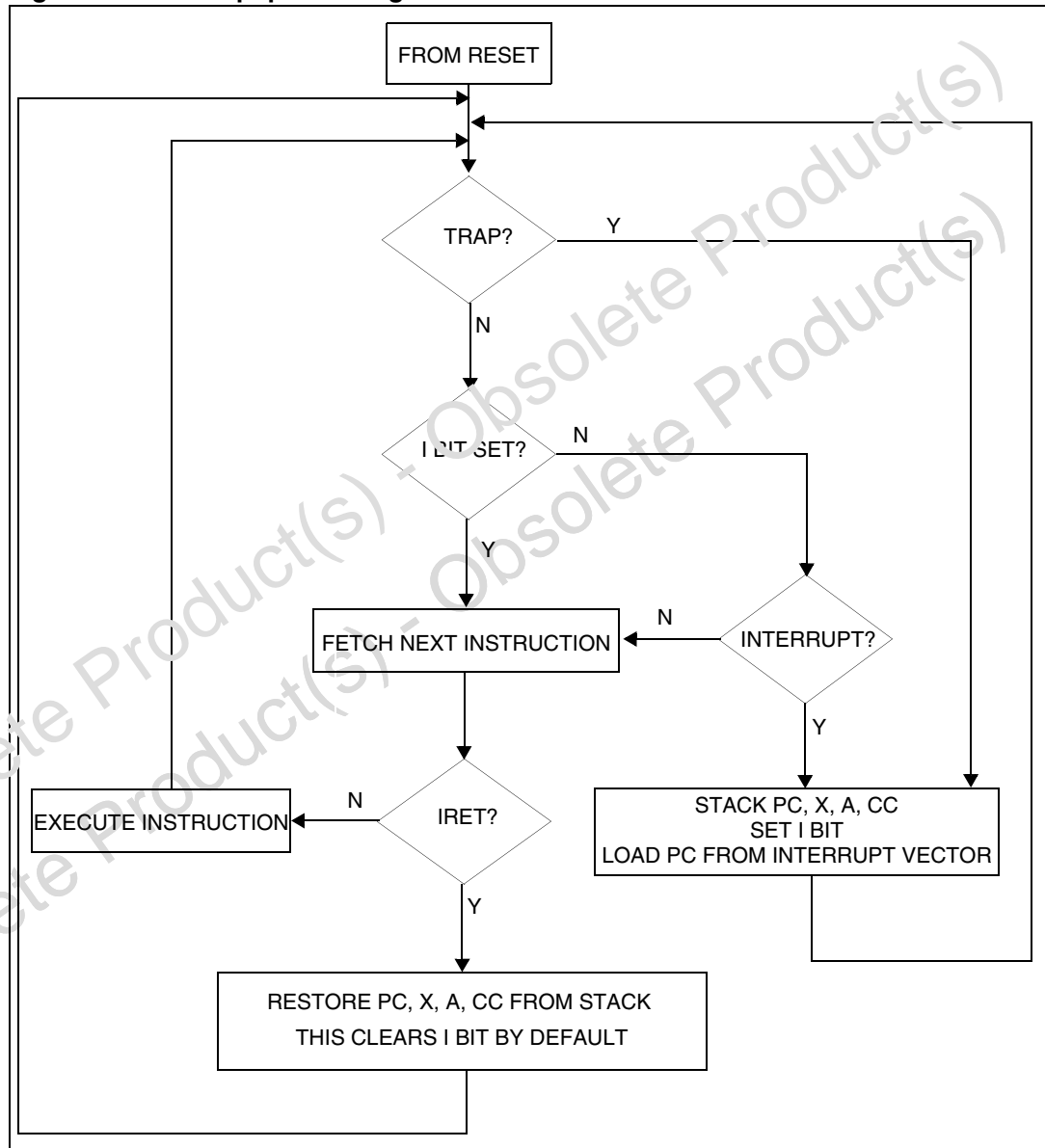

4.5 Register description

Table 7. External interrupt register map

Address	Reset		Register	bit 7	bit 6	bit 5	bit 4	bit 3	bit 2	bit 1	bit 0
000Ch	00h	R/W	ITRFRE	0	0	ITB EDGE	ITBLAT	ITBITE	ITA EDGE	ITALAT	ITAITE

External interrupt register (ITRFRE)

Read/Write

Reset value:00h

7	6	5	4	3	2	1	0
0	0	ITBEDGE	ITBLAT	ITBITE	ITAEDGE	ITALAT	ITAITE

Bit 7 =Reserved. Force by hardware to 0.

Bit 6 =Reserved. Force by hardware to 0.

Bit 5 = ITBEDGE Interrupt B Edge Selection. This bit is set and cleared by software.

0: Falling edge detected on ITB (default)

1: Rising edge detected on ITB

Bit 4 = ITBLAT Falling or Rising Edge Detector Latch. This bit is set by hardware, when a falling or rising edge, depending on the sensitivity, occurs on ITB/PA7 pin. An interrupt is generated if ITBITE=1. It is cleared by software.

0: No edge detected on ITB (default)

1: Edge detected on ITB

Bit 3 = ITBITE ITB Interrupt Enable. This bit is set and cleared by software.

0: ITB interrupt disabled (default)

1: ITB interrupt enabled

Bit 2 = ITAEDGE Interrupt A Edge Selection. This bit is set and cleared by software.

0: Falling edge detected on ITA (default)

1: Rising edge detected on ITA

Bit 1 = ITALAT Falling or Rising Edge Detector Latch. This bit is set by hardware when a falling or a rising edge, depending on the sensitivity, occurs on ITA/PA6 pin. An interrupt is generated if ITAITE=1. It is cleared by software.

0: No edge detected on ITA (default)

1: Edge detected on ITA

Bit 0 = ITAITE ITA Interrupt Enable. This bit is set and cleared by software.

0: ITA interrupt disabled (default)

1: ITA interrupt enabled

Table 8. Interrupt mapping

Source block	Description	Register label	Flag	Maskable	Vector address	Priority order
RESET	Reset	N/A	N/A	no	FFFEh-FFFFh	Highest Priority  Lowest Priority
TRAP	Software	N/A	N/A	no	FFFCh-FFFDh	
Not used					FFFAh-FFFBh	
DDC/CI A	DDC Interrupt	DDCSR1A DDCSR2A	**	yes	FFF8h-FFF9h	
DDC2B A	End of communication Interrupt	DDCDCRA	ENDCF	yes	FFF6h-FFF7h	
	End of download Interrupt		EDF	yes	FFF6h-FFF7h	
DDC/CI B	DDC Interrupt	DDCSR1B DDCSR2B	**	yes	FFF4h-FFF5h	
DDC2B B	End of communication Interrupt	DDCDCRB	ENDCF	yes	FFF2h-FFF3h	
	End of download Interrupt		EDF	yes	FFF2h-FFF3h	
Not used					FFF0h-FFF1h	
IFR	IFR Interrupt	IFRCR		yes	FFEEh-FFEFh	
Port A bit 6	External Interrupt ITA	ITRFRE	ITALAT		FFCh-FFEDh	
Port A bit 7	External Interrupt ITB	ITRFRE	ITBLAT	yes	FFEAh-FFEBh	
I2C	I2C Peripheral Interrupts	I2CSR1 I2CSR2	**	yes	FFE8h-FFE9h	
Not used					FFE6h-FFE7h	
TIMB	Timer B overflow	TIMCSRB	TOF	yes	FFE4h-FFE5h	
TIMA	Timer A overflow	TIMCSRA	TOF	yes	FFE2h-FFE3h	
Not used					FFE0h-FFE1h	

** Many flags can cause an interrupt, see peripheral interrupt status register description.

5 Flash program memory

The ST7 dual voltage High Density Flash (HDFlash) is a non-volatile memory that can be electrically erased as a single block or by individual sectors and programmed on a Byte-by-Byte basis using an external Vpp supply.

The HDFlash devices can be programmed and erased off-board (plugged in a programming tool) or on-board using ICP (In-Circuit Programming) IAP (In-Application Programming).

The array matrix organisation allows each sector to be erased and reprogrammed without affecting other sectors.

5.1 Main features

- Three Flash programming modes:
 - Insertion in a programming tool. In this mode, all sectors including option bytes can be programmed or erased
 - ICP (In-Circuit Programming). In this mode, all sectors including option bytes can be programmed or erased without removing the device from the application board.
 - IAP (In-Application programming). In this mode, all sectors except Sector 0 can be programmed or erased without removing the device from the application board and while the application is running
- ICT (In-Circuit Testing) for downloading and executing user application test patterns in RAM
- Read-out protection against piracy
- Register Access Security System (RASS) to prevent accidental programming or erasing

5.2 Structure

The Flash memory is organized in sectors and can be used for both code and data storage. Depending on the overall Flash memory size in the microcontroller device, three user sectors are available. Each sector is independently erasable. Thus, complete erasing of the whole Flash memory is avoided when only partial erasing is required.

The first two sectors have a fixed size of 4 Kbyte (see [Figure 11](#)). They are mapped in the upper part of the ST7 addressing space to the reset and interrupt vectors are located in Sector 0 (F000h-FFFFh).

5.3 Program memory read-out protection

The read-out protection is enabled through an option bit.

When this option is selected, the programs and data stored in the program memory (Flash or ROM) are protected against read-out piracy (including a re-write protection). In Flash devices, when this protection is removed by reprogramming the Option Byte, the entire program memory is first automatically erased. Refer to the [Section 5.7](#) for more details.

Figure 11. Memory map and sector address.

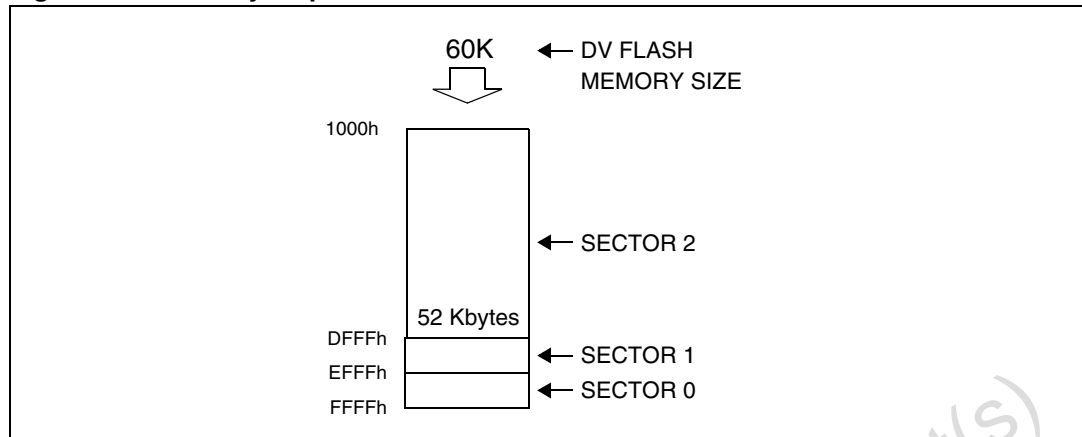

5.4 ICP (in-circuit programming)

To perform ICP, the microcontroller must be switched to ICC (In circuit Communication) mode by an external controller or programming tool.

Depending on the ICP code downloaded in RAM, Flash memory programming can be fully customized (number of bytes to program, program locations or selection serial communication interface for downloading).

When using a STMicroelectronics or third party programming tool that supports ICP and the specific microcontroller device, the user only needs to implement the ICP hardware interface on the application board (see [Figure 12](#)). For more details on the pin locations, refer to the device pin description.

ICP needs a minimum of 4 and up to 6 pins to be connected to the programming tool. these pins are:

- $\overline{\text{RESET}}$: device reset
- VSS: device power supply ground
- ICC-CLK: ICC output serial clock pin
- ICC-DATA: ICC input serial data pin
- VPP: programming voltage
- VDD: application board power supply

Note: 1 If the ICC-CLK or ICC-DATA pins are only used as outputs in the application, no signal isolation is necessary. As soon as the Programming Tool is plugged to the board, even if an ICC session is not in progress, the ICC-CLK and ICC-DATA pins are not available for the application. If they are used as inputs by the application, isolation such as a serial resistor has to be implemented in case another device forces the signal. Refer to the Programming Tool documentation for recommended resistor values.

2 During the ICC session, the programming tool must control the $\overline{\text{RESET}}$ pin. This can lead to conflicts between the programming tool and the application reset circuit if it drives more than 5mA at high level (push pull output or pull-up resistor < 1K). A Schottky diode can be used to isolate the application RESET circuit in this case. When using a classical RC network with $R > 1K$ or a reset management IC with open drain output and pull-up resistor > 1K, no

additional components are needed. In all cases the user must ensure that no external reset is generated by the application during the ICC session.

- 3 The use of Pin 7 of the ICC connector depends on the Programming Tool architecture. This pin must be connected when using most ST Programming Tools (it is used to monitor the application power supply)..

Figure 12. Typical ICP interface

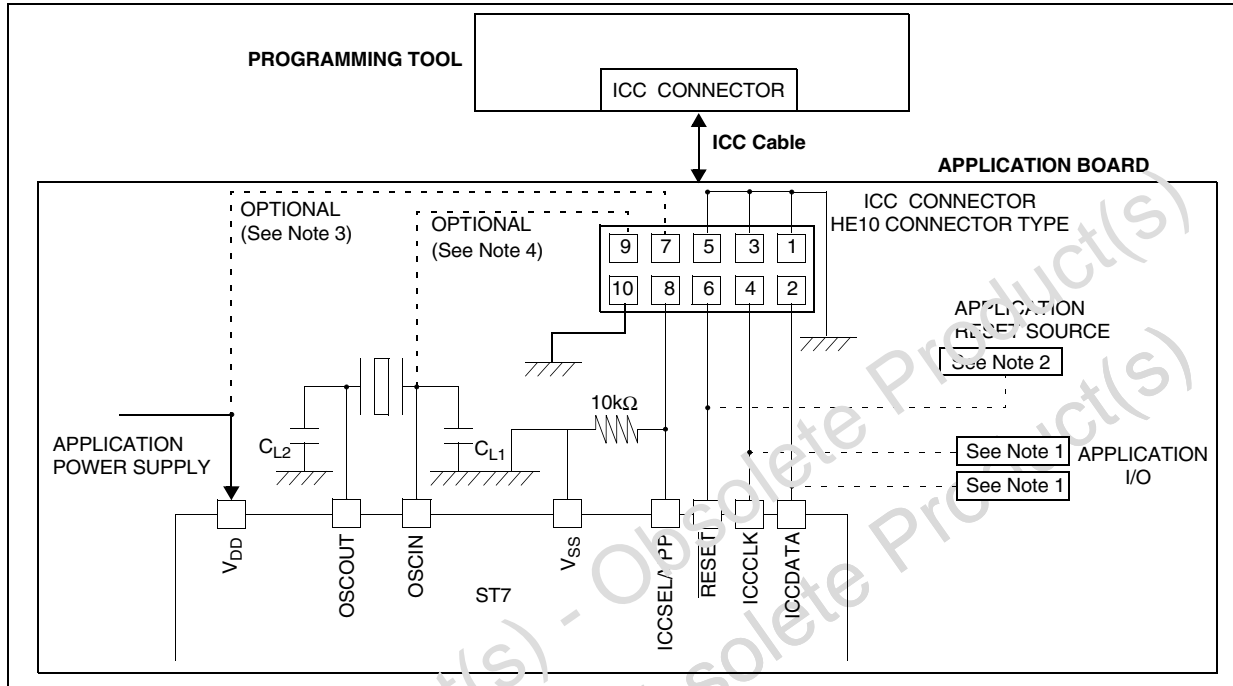

5.5 IAP (in-application programming)

This mode uses a boot loader program previously stored in Sector 0 by the user (in ICP mode or by plugging the device in a programming tool).

This mode is fully controlled by user software. This allows it to be adapted to the user application, (user-defined strategy for entering programming mode, choice of communications protocol used to fetch the data to be stored, etc.). For example, it is possible to download code from the SPI, SCI, USB or CAN interface and program it in the Flash. IAP mode can be used to program any of the Flash sectors except Sector 0, which is write/erase protected to allow recovery in case errors occur during the programming operation.

5.6 Register description

Flash control/status register (FCSR)

Read/Write

Reset Value: 0000 0000 (00h)

7	6	5	4	3	2	1	0
0	0	0	0	0	0	0	0

This register is reserved for use by Programming Tool software. It controls the Flash programming and erasing operations.

5.7 Flash option bytes

Each device is available for production in user programmable versions (FLASH) as well as in factory coded versions (ROM). FLASH devices are shipped to customers with a default content (FFh), while ROM factory coded parts contain the code supplied by the customer. This implies that FLASH devices have to be configured by the customer using the Option Bytes while the ROM devices are factory-configured.

The option bytes are used to select the hardware configuration of the microcontroller. They have no address in the memory map and can be accessed only in programming mode (for example using a standard ST7 programming tool). The default content of the FLASH is fixed to FFh. To program directly the FLASH devices using ICP, FLASH devices are shipped to customers with the internal RC clock source enabled. In masked ROM devices, the option bytes are fixed in hardware by the ROM code.

Static option byte 1

	7	6	5	4	3	2	1	0
								FMP_R
Default	1	1	1	1	1	1	1	1

OPT0= **FMP_R** Flash memory read-out protection

This option indicates if the user flash memory is protected against read-out piracy. This protection is based on a read and write protection of the memory in test modes and ICP mode. Erasing the option bytes when the FMP_R option is selected causes the whole user memory to be erased first.

0: Read-out protection enabled

1: Read-out protection disabled

Static option byte 2

	7	6	5	4	3	2	1	0
Default	1	1	1	1	1	1	1	1

6 Clocks and low power modes

6.1 Clock system

6.1.1 General description

To operate, the device needs a number of clock signals. All clock signals derive from the root 24MHz clock signal CkXT provided at the output of the "OSC" circuit (refer to [Figure 13](#)). If a 24MHz quartz crystal is applied on pins OSCIN, OSCOUT, the OSC operates in a crystal-controlled oscillator mode. An external clock signal can also be applied on OSCIN pin, putting the OSC in external clock mode operation.

The block diagram in [Figure 13](#) shows the basic configuration of the clock system.

Figure 13. Main clock generation

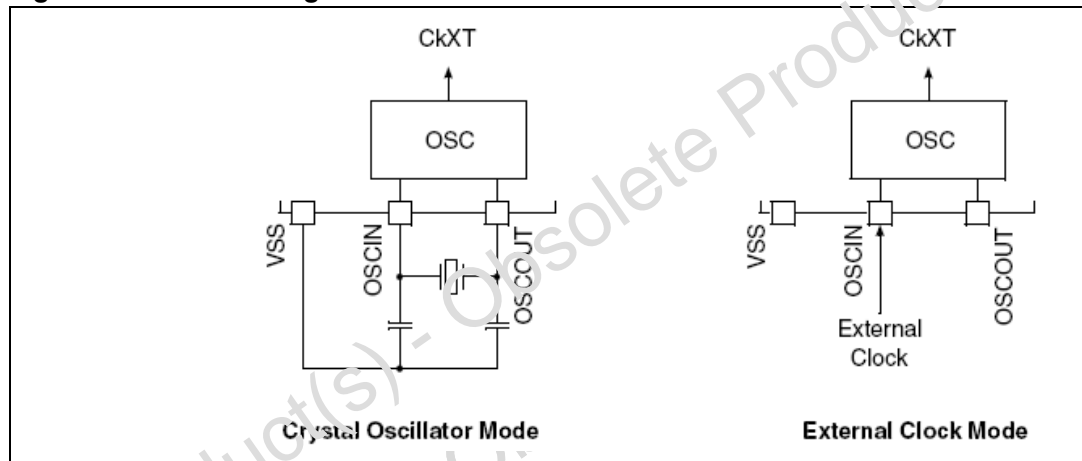

6.1.2 Crystal oscillator mode

In this mode, the root clock is generated by on-chip oscillator controlled by an external parallel fundamental-mode quartz crystal. General design precautions must be followed to ensure a maximum stability. Foot capacitors C_{L1} and C_{L2} must be adapted to match the crystal used. A 100Kohms resistor is internally connected to OSCIN and OSCOUT.

Note:

If a Murata ceramic resonator is to be used, Murata recommends their CERALOCK® CSTCGseries (fundamental type) with built-in CL1 and CL2 capacitors, such as:-

CSTCG24M0V51-R0 for 24-MHz external, 8-MHz internal clock operation

CSTCG27M0V51-R0 for 27-MHz external, 9-MHz internal clock operation

No additional external capacitor is therefore needed with either model of this series.

6.1.3 External clock mode

In this mode, an external clock is provided on pin OSCIN, while the OSCOUT is left open ([Figure 13](#)). The signal is internally buffered before feeding the following stages. There is the same emphasis on stability of the external clock as in crystal oscillator mode.

6.1.4 Clock signals

The root clock is divided by factors of 3, to obtain CPU clock (f_{CPU}).

Figure 14. Clock system diagram

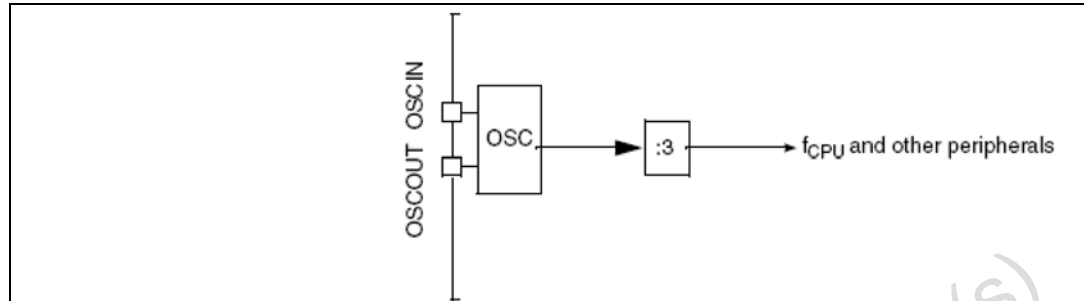

6.2 Power saving modes

MCU offers the possibility to decrease power consumption at any time by software operation.

6.2.1 HALT mode

The HALT mode is the MCU lowest power consumption mode. Meanwhile, the HALT mode also stops the oscillator stage completely, which is the most critical condition (MCU cannot recover by itself). For this reason, the HALT mode is not compatible with the watchdog protection:

Table 9. Watchdog compatibility

Watchdog	Executing HALT instruction
Enabled	Generates an immediate reset
Disabled	Puts the MCU in HALT mode

6.2.2 WAIT mode

This mode is a low power consumption mode. The WFI instruction sets the MCU in WAIT mode: The internal clock remains active but all CPU processing is stopped; however, all other peripherals still run.

Note: In WAIT mode DMA (DDCs) accesses are possible.

6.2.3 Exit from HALT and WAIT modes

The MCU can exit HALT mode at reception of an external interrupt: ITA or ITB. The oscillator is then turned on and a stabilizing time is necessary before releasing CPU operation (4096 CPU clock cycles). After this delay, the CPU continues operation according to what caused its release, either by servicing an interrupt or by fetching the reset vector in case of reset.

During WAIT mode, the I bit from the condition code register is cleared, enabling all interrupts. This leads the MCU to exit WAIT mode, the corresponding interrupt vector to be fetched, the interrupt routine to be executed and normal processing to resume.

A reset causes the program counter to fetch the reset vector. Processing starts as with a normal reset.

Figure 15. Wait flow chart

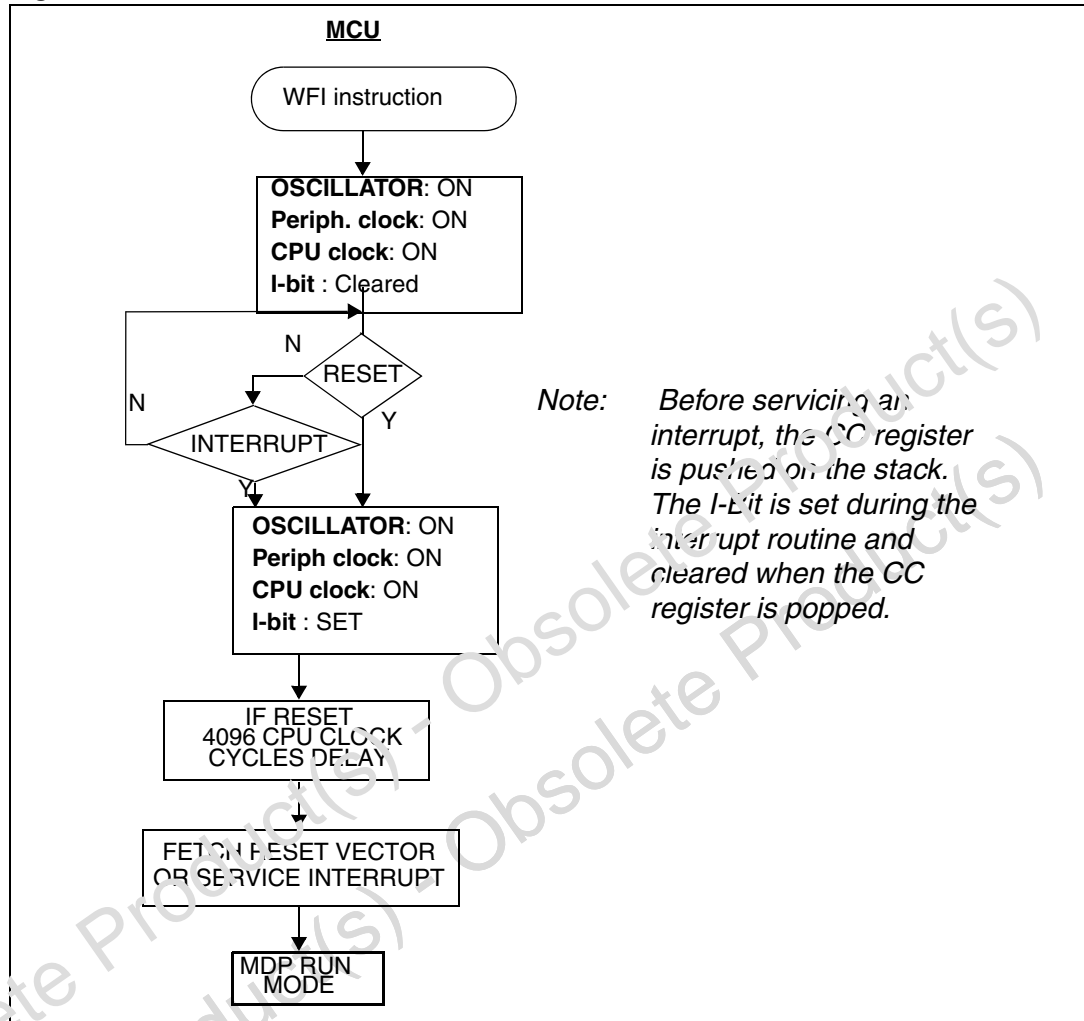

6.2.4 Selected peripherals mode

Some peripherals have an “on/off “bit to disconnect the block (or part of) and decrease the MCU power consumption (configuration by default at reset):

Table 10. Peripheral modes

	Bits	Register	Comment	Reset
PORTs	PxDDi	PxDDR	cut the output function pad (input mode)	OFF
ADC	ADON	ADCSR	cut analog consumption and clock	OFF
PWMi	OEi	PWMCRx	cut the pad consumption	OFF
DDC	PE, DDC2BPE	DDCCR, DDCDCR		OFF
WDG	WGDA	WDGCR	cut the output reset	OFF
I2C	PE	I2CCR		OFF

7 I/O ports

I/O ports are used to transfer data through digital inputs and outputs. For specific pins, I/O ports allow the input of analog signals or the Input/Output of alternate signals for on-chip peripherals (DDC, Timer...).

Each pin can be independently programmed as digital input or output. Each pin can be an analog input when an analog switch is connected to the Analog Digital Converter (ADC).

Figure 16. I/O pin critical circuit

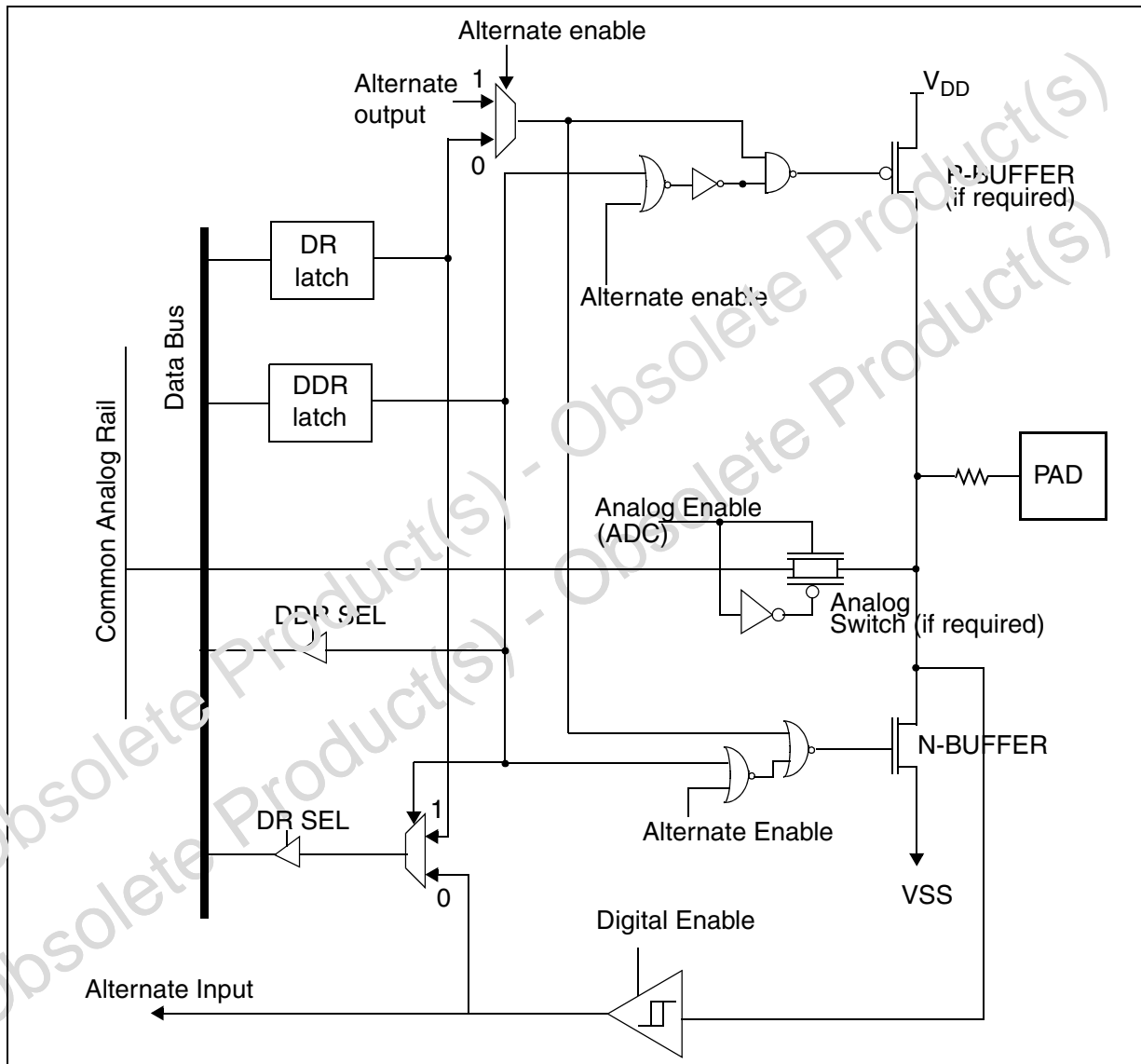

Note: This is the typical I/O pin configuration. Each port is customized with a specific configuration in order to handle certain functions.

Table 11. I/O pin function

DDR	Mode
0	Input
1	Output

7.1 Common functional description

Each port pin of the I/O Ports can be individually configured as either input or output, under software control.

Each bit of Data Direction Register (DDR) corresponds to an I/O pin of the associated port. This corresponding bit must be set to configure its associated pin as output and must be cleared to configure its associated pin as input. The Data Direction Registers can be read and written.

The typical I/O circuit is shown in [Figure 15](#). Any write to an I/O port updates the port data register even when configured as input. Any read of an I/O port returns either the data latched in the port data register (pins configured as output) or the value of the I/O pins (pins configured as input).

Remark: when there is no I/O pin inside an I/O port, the returned value is logic (pin configured as input).

At reset, all DDR registers are cleared, configuring all I/O ports as inputs. Data Registers (DR) are also cleared at reset.

Input mode

When DDR=0, the corresponding I/O is configured in Input mode.

In this case, the output buffer is switched off, the state of the I/O is readable through the Data Register address, coming directly from the TTL Schmitt Trigger output and not from the Data Register output.

Output mode

When DDR=1, the corresponding I/O is configured in Output mode.

In this case, the output buffer is activated according to the Data Register content.

A read operation is directly performed from the Data Register output.

Analog input

Each I/O can be used as analog input by adding an analog switch driven by the Analog Digital Converter. The I/O must be configured in Input before using it as analog input.

When the analog channel is selected by the ADC the analog value is directly driven to the ADC through an analog switch.

Alternate mode

A signal coming from an on-chip peripheral is an output on the I/O, the latter then being automatically configured in output mode.

The signal coming from the peripheral enables the alternate signal to be output. A signal coming from an I/O can be input in an on-chip peripheral.

An alternate Input must first be configured in Input mode (DDR=0). Alternate and I/O Input configurations are identical without pull-up. The signal to be input in the peripheral is taken after the TTL Schmitt trigger when available.

The I/O state is readable as in Input mode by addressing the corresponding I/O Data Register.

7.2 Port A

Each Port A bit can be defined as an Input line or as a Push-Pull. It can be also be used to output the PWM outputs.

Table 12. Port A descriptions

Port A	I/O		Alternate function	
	Input ⁽¹⁾	Output	Signal	Condition
PA0	With weak pull-up	Push-pull	PWM0	OE0=1 (PWM)
PA1	With weak pull-up	Push-pull	PWM1	OE1=1 (PWM)
PA2	With weak pull-up	Push-pull	PWM2	OE2=1 (PWM)
PA3	With weak pull-up	Push-pull	PWM3	OE3=1 (PWM)
PA4	With weak pull-up	Push-pull	PWM4	OE4=1 (PWM)
PA5	With weak pull-up	Push-pull	PWM5	OE5=1 (PWM)
	With weak pull-up		BUZOUT	BUZEN = 1 (timer A) ⁽²⁾
PA6	With weak pull-up	Push-pull	External interrupt ITA	see external interrupt register description
PA7	With weak pull-up	Push-pull	External interrupt ITB	

1. Reset state

2. If both PWM5 and BUZOUT are enabled, BUZOUT has priority over PWM5.

Outputs PA4 and PA5 may also be configured as high current (8 mA) push-pull outputs by means of the MISCR register.

Miscellaneous register (MISCR)

Read/Write

Reset value:00h

7	6	5	4	3	2	1	0
0	0	0	0	0	PA5OVD	PA4OVD	0

Bits [7:3] = Reserved. Forced by hardware to 0.

Bit 2 = PA5OVD Port A Bit 5 Overdrive

This bit is set and cleared by software. It is used only if Port A Bit 5 is set as an output (PADDR, PWM5 or BUZOUT). It has no effect if set as an input.

0: 2 mA Push-pull Output

1: 8 mA Push-pull Output

Bit 1 = PA4OVD Port A Bit 4 Overdrive

This bit is set and cleared by software. It is used only if Port A Bit 4 is set as an output (PADDR or PWM4). It has no effect if set as an input.

0: 2 mA Push-pull Output

1: 8 mA Push-pull Output

Bit 0 = Reserved. Must be cleared by software.

Figure 17. Port A [5:0]

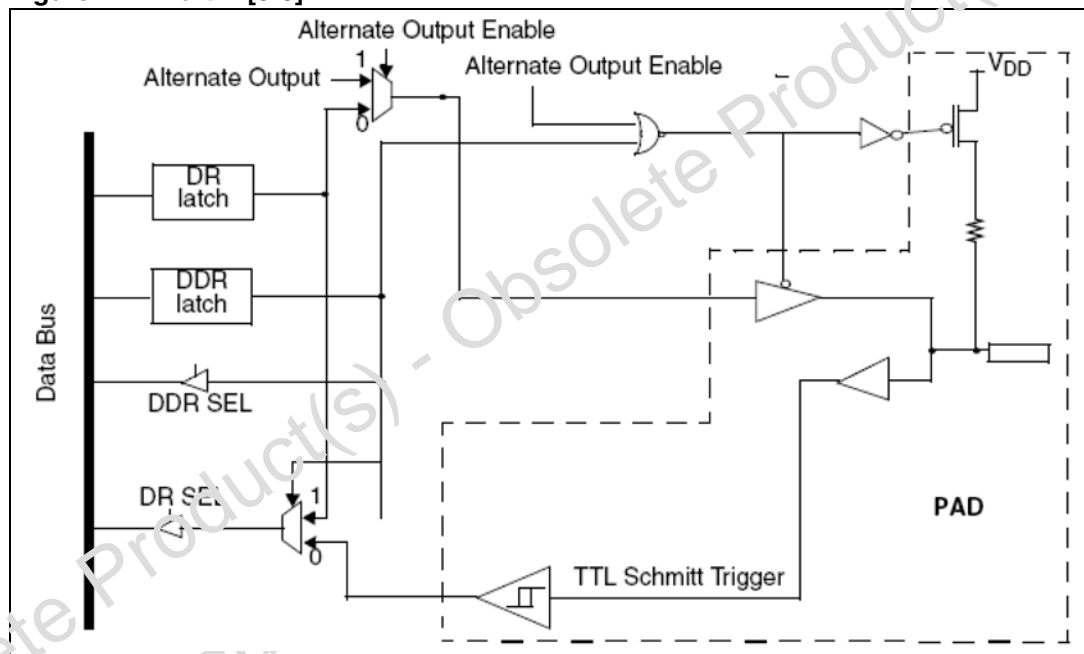
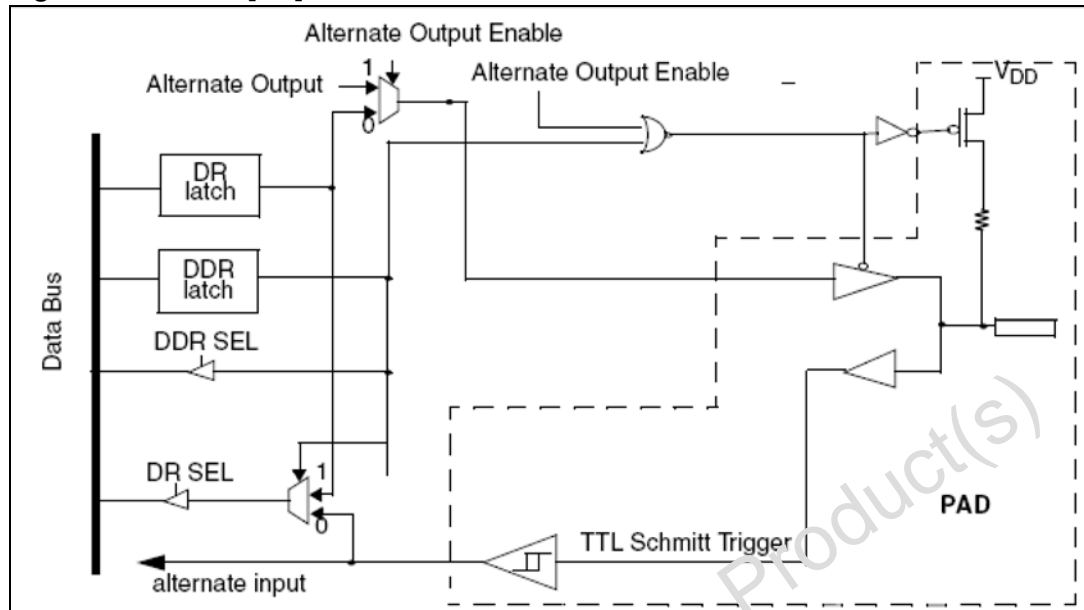

Figure 18. Port A [7:6]



7.3 Port B

Each port B bit can be used as the Analog source to the Analog Digital Converter.

Only one I/O line at a time must be configured as an analog input. Pins levels are all limited to 5V.

All unused I/O lines should be tied to an appropriate logic level (either V_{DD} or V_{SS}).

Since ADC and microprocessor are on the same chip and if high precision is required, the user should not switch heavily loaded signals during conversion. Such switching will affect the supply voltages used as analog references. The conversion accuracy depends on the quality of power supplies (V_{DD} and V_{SS}). The user must take special care to ensure that a well regulated reference voltage is present on V_{DD} and V_{SS} pins (power supply variations must be less than 3.3V/ms). This implies, in particular, that a suitable decoupling capacitor is used at V_{DD} pin.

Table 13. Port B description

PORT B	I/O		Alternate Function	
	Input*	Output	Signal	Condition
PB0	With weak pull-up when digital input	Push-pull	Analog input (ADC):AIN0	ADON = 1 & CH[1:0]=00 (ADCCSR)
PB1	With weak pull-up when digital input	Push-pull	Analog input (ADC) AIN1	ADON = 1 & CH[1:0]=01 (ADCCSR)
PB2	With weak pull-up when digital input	Push-pull	Analog input (ADC) AIN2	ADON = 1 & CH[1:0]=10 (ADCCSR)

Table 13. Port B description

PORT B	I/O		Alternate Function	
	Input*	Output	Signal	Condition
PB3	With weak pull-up when digital input	Push-pull	Analog input (ADC) AIN3/ IFR	ADON = 1 & CH[1:0]=11 (ADCCSR) for analog input in this case, IFR is disabled

*Reset State

Figure 19. Port B [2:0]

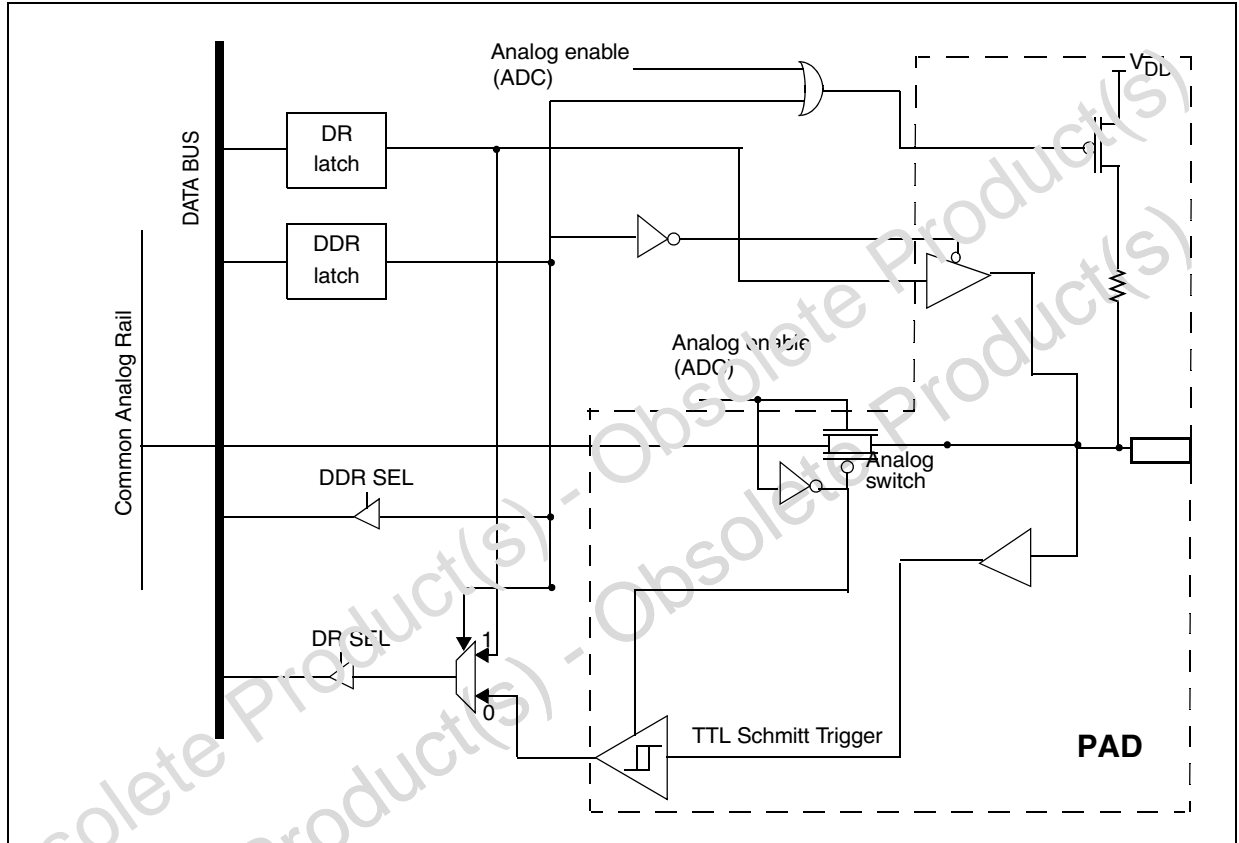
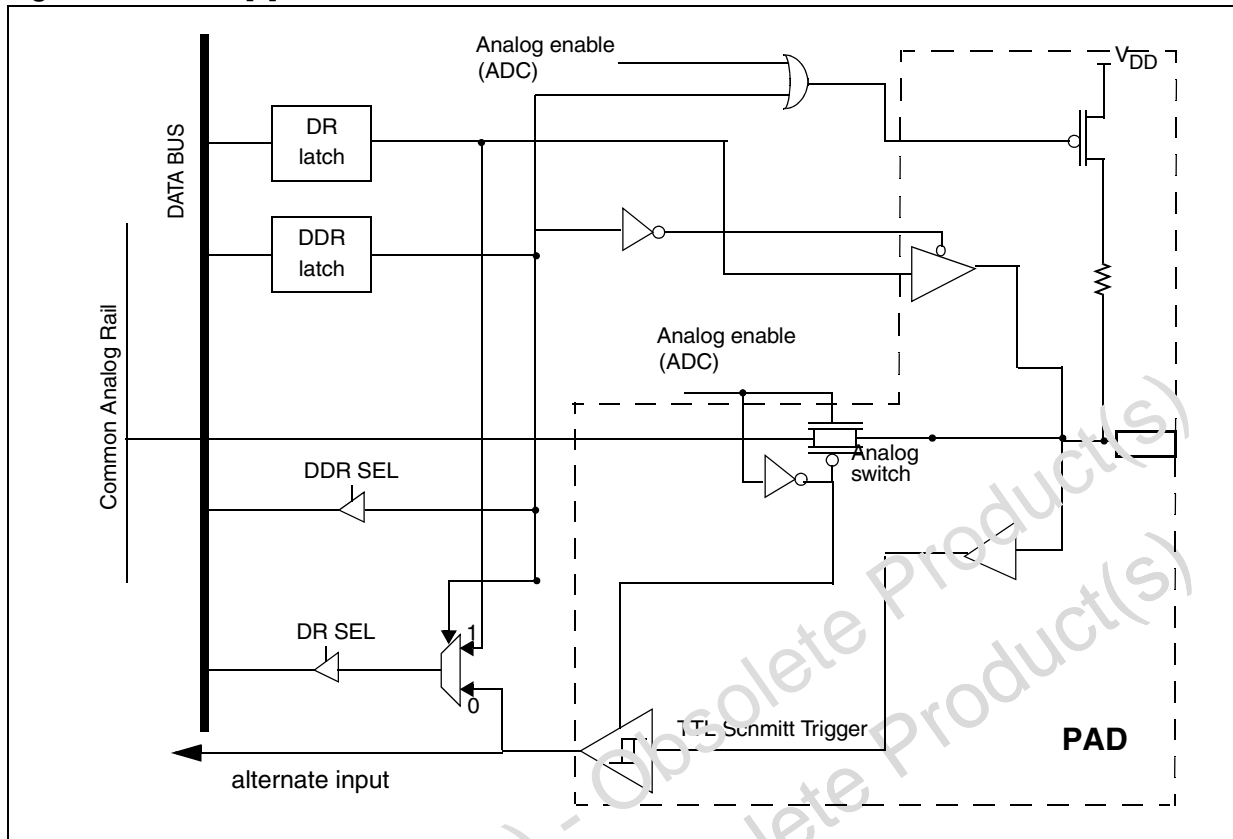

Figure 20. Port B [3]



7.4 Port C

The available port pins of port C may be used as general purpose I/O.

Table 1.1. Port C description

PORT C	I / O		Alternate Function	
	Input*	Output	Signal	Condition
PC0	Without pull-up	Open-drain		
PC1	Without pull-up	Open-drain		

*Reset state

Note: These 2 pins are reserved for ICC use during ICC communication. If ICC is not used at all, they can be used as general purpose I/Os.

Table 15. Port D description (continued)

PORT D	I / O		Alternate Function	
	Input*	Output	Signal	Condition
PD4	Without pull-up	open-drain	SCLD B (input with TTL schmitt trigger or open-drain output)	DDC B enable
PD5	Without pull-up	open-drain	SDAD B (input with TTL schmitt trigger or open-drain output)	DDC B enable
PD6	Without pull-up	open-drain		
PD7	Without pull-up	open-drain		

*Reset State

Figure 22. Port D

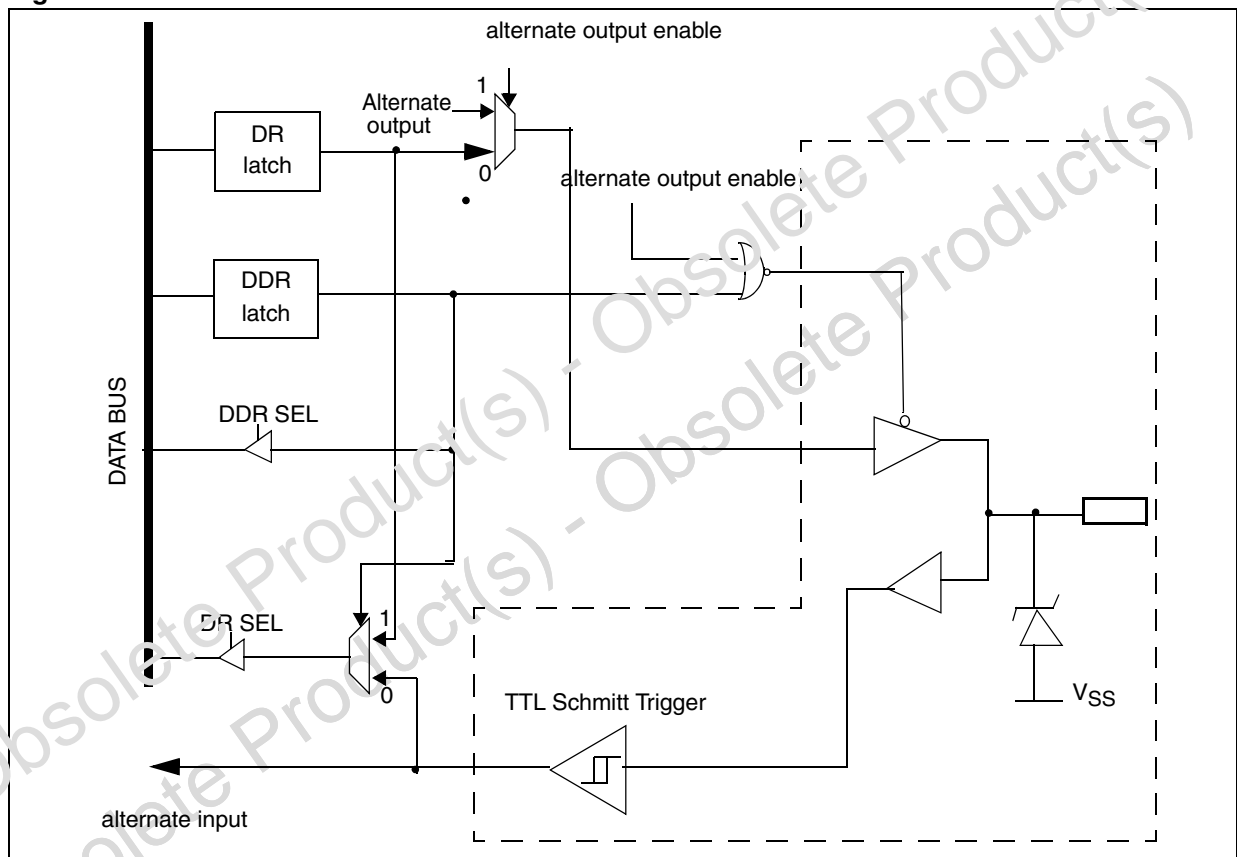

7.6 Register description

Data registers (PxDR)

Data direction registers (PxDDR)

(x corresponds to an I/O pin of the associated port. In input mode the value is 00h by default).

Table 16. I/O ports register map

Address	Reset		Register	bit 7	bit 6	bit 5	bit 4	bit 3	bit 2	bit 1	bit 0
0002h	00h	R/W	PADR	PADR[7:0]							
0003h	00h	R/W	PADDR	PADDR[7:0]							
0004h	00h	R/W	PBDR	PBDR[7:0]							
0005h	00h	R/W	PBDDR	PBDDR[7:0]							
0006h	00h	R/W	PCDR	PCDR[7:0]							
0007h	00h	R/W	PCDDR	PCDDR[7:0]							
0008h	00h	R/W	PDDR	PDDR[7:0]							
0009h	00h	R/W	PDDDR	PDDDR[7:0]							

8 PWM generator

This PWM on-chip peripheral consists of two blocks, each one with its own 8-bit auto-reload counter.

The first block (Block A) outputs up to four separate PWM signals at the same frequency. The second block (Block B) outputs up to two separate PWM signals at another frequency.

Each PWM output may be enabled or disabled independently of the other. The polarity of each PWM output may also be independently set.

8.1 Main features

- Two distinct programmable frequencies between 31.250 kHz and 8 MHz
- Resolution: t_{CPU}

8.2 Functional description

The free-running 8-bit counter is fed by the CPU clock and increments on every rising edge of the clock signal.

When a counter overflow occurs, the counter is automatically reloaded with the contents of the ARR register.

Each PWMx output signal can be enabled independently using the corresponding OEx bit in the PWM control register (PWMCR). When this bit is set, the corresponding I/O is configured as an output push-pull alternate function.

PWM[3:0] all have the same frequency which is controlled by counter period A and the ARR register value.

$$f_{PWM A} = f_{COUNTER A} / (256-ARRA)$$

PWM[5:4] all have the same frequency which is controlled by counter period B and the ARR register value.

$$f_{PWM B} = f_{COUNTER B} / (256-ARRB)$$

When a counter overflow occurs, the PWMx pin level is toggled depending on the corresponding OPx (output polarity) bit in the PWMCR register. When the counter reaches the value contained in one of the Duty Cycle registers (DCR1x), the corresponding PWMx pin level is restored.

This DCR1x register can not be accessed directly, it is loaded from the Duty Cycle register (DCRx) at each overflow of the counter. This double buffering method prevents glitch generation when changing the duty cycle on the fly.

Note: The reload values will also affect the value and the resolution of the duty cycle of the PWM output signal. To obtain a signal on a PWMx pin, the contents of the DCRx register must be greater than or equal to the contents of the ARR register. The maximum available resolution for duty cycle is $1/(256-ARR)$.

Figure 23. PWM block diagram

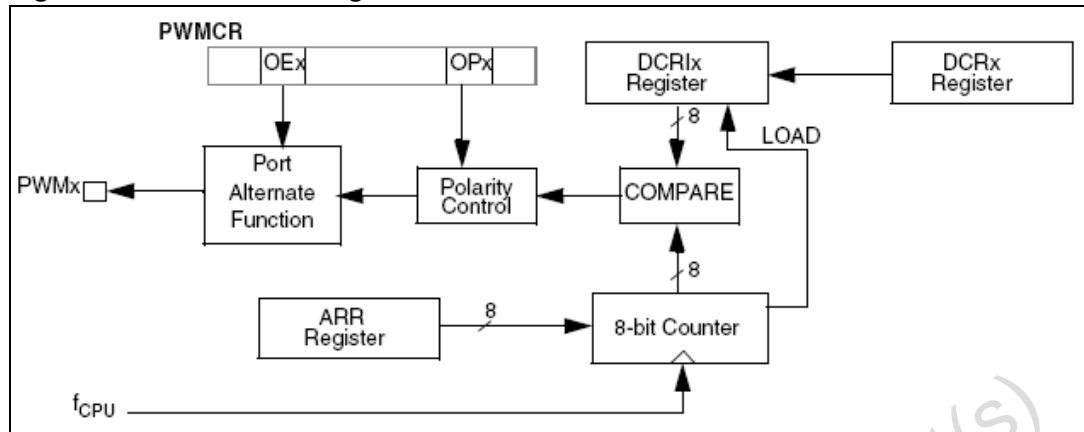

Figure 24. PWM generation

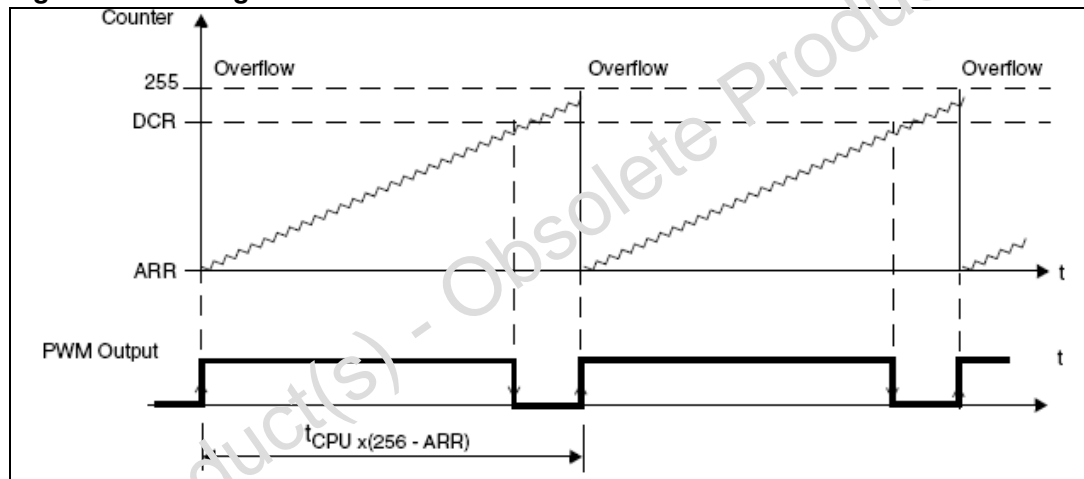

Figure 25. PWM generation

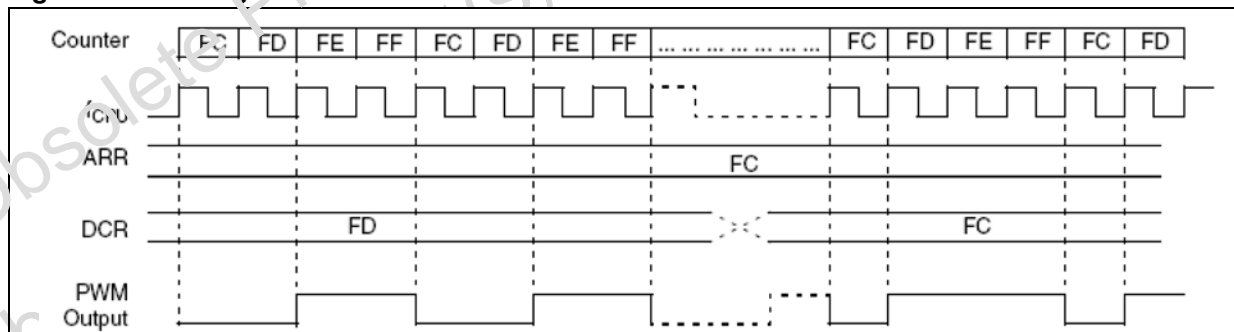

Table 17. Pulse width in t_{CPU}

	Pulse width in t_{CPU}
$DCR \geq ARR$	$DCR - ARR + 1$
$DCR = ARR$	1
$DCR < ARR$	0 (output will not toggle)

$$\text{Duty Cycle} = \frac{\text{DCR} + 1}{256 - \text{ARR}}$$

This Pulse Width modulated signal must be filtered, using an external RC network placed as close as possible to the associated pin. This provides an analog voltage proportional to the average charge through the external capacitor. Thus for a higher mark/space ratio (High time much greater than Low time) the average output voltage is higher. The external components of the RC network should be selected for the filtering level required for control of the system variable.

Table 18. 8-bit PWM ripple after filtering

C _{EXT}	V _{RIPPLE}
470 nF	60 mV
1 μF	27 mV
4.7 μF	6 mV

$$V_{\text{RIPPLE}} = \frac{(1 - e^{-1/2 \times C_{\text{EXT}} \times R_{\text{EXT}} \times f_{\text{PWM}}})^2}{|1 - e^{-1/(C_{\text{EXT}} \times R_{\text{EXT}} \times f_{\text{PWM}})}|} \times V_{\text{DD}}$$

With:

R_{ext} = 1 kΩ

f_{PWM} = f_{CPU} / (256 - ARR)

f_{CPU} = 8MHz

V_{DD} = 5V

Worst case PWM Duty Cycle 50%

Figure 26. PWM simplified voltage output after filtering

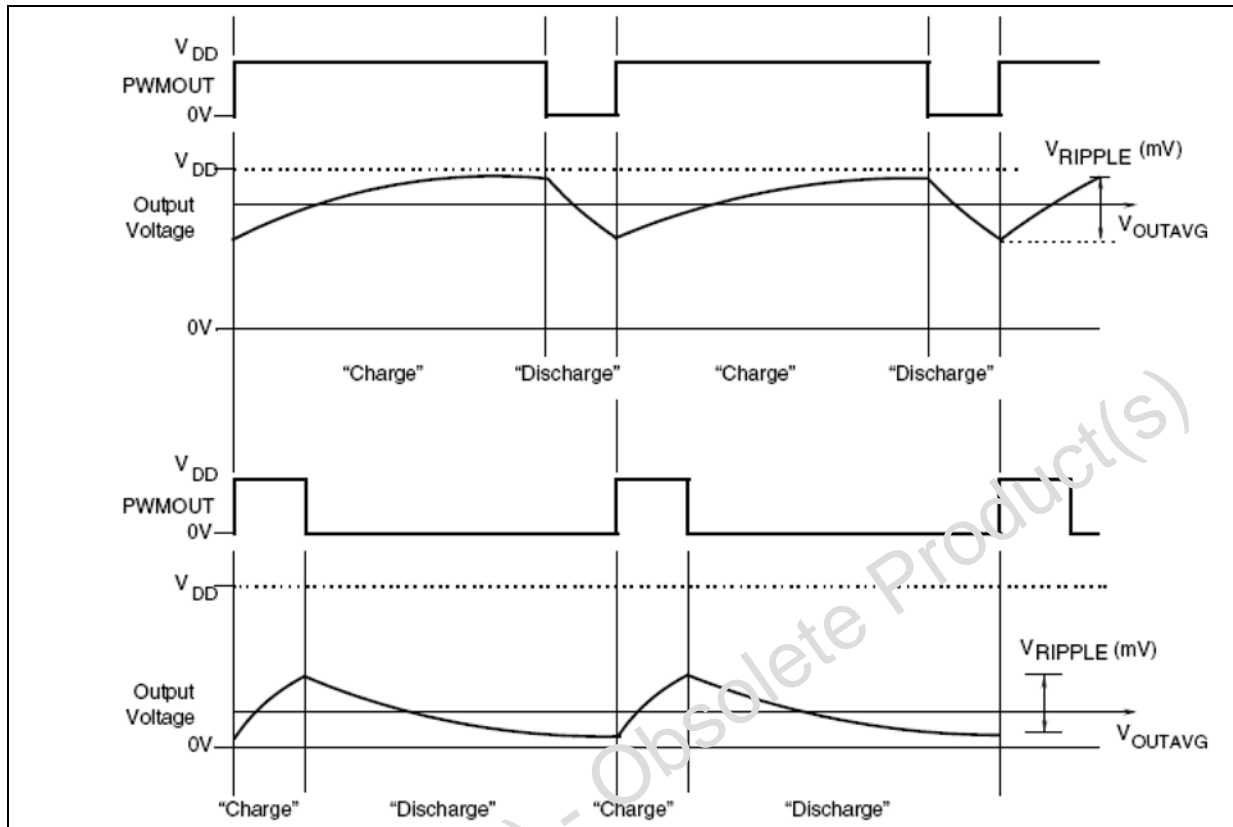

8.3 Register description

Each PWM is associated with two control bits (OEx and OPx) and a control register (DCRx).

Table 19. PWM register map

Address	Reset		Register	Bit 7	Bit 6	Bit 5	Bit 4	Bit 3	Bit 2	Bit 1	Bit 0		
00Fh	00h	R/W	PWMDCR0	DCR0[7:0]									
0C10h	00h	R/W	PWMDCR1	DCR1[7:0]									
0011h	00h	R/W	PWMDCR2	DCR2[7:0]									
0012h	00h	R/W	PWMDCR3	DCR3[7:0]									
0013h	00h	R/W	PWMCRA	OE3	OE2	OE1	OE0	OP3	OP2	OP1	OP0		
0014h	FFh	R/W	PWMARRA	ARRA[7:0]									
0015h	00h	R/W	PWMDCR4	DCR4[7:0]									
0016h	00h	R/W	PWMDCR5	DCR5[7:0]									
0017h	00h	R/W	PWMCRB	0	0	OE5	OE4	0	0	OP5	OP4		
0018h	FFh	R/W	PWMARRB	ARRB[7:0]									

Duty cycle registers (PWMDCRx)

Read/Write

Reset value 0000 0000 (00h)

7	6	5	4	3	2	1	0
DC7	DC6	DC5	DC4	DC3	DC2	DC1	DC0

Bits [7:0] = DC[7:0] duty cycle data

These bits are set and cleared by software. A DCRx register is associated with the DCRix register of each PWM channel to determine the second edge location of the PWM signal (the first edge location is common to all 4 channels and given by the ARR register). These DCR registers allow the duty cycle to be set independently for each PWM channel.

Control register A (PWMCRA)

Read/Write

Reset Value: 0000 0000 (00h)

7	6	5	4	3	2	1	0
OE3	OE2	OE1	OE0	OP3	OP2	OP1	OP0

Bits [7:4] = OE [3:0] PWM output enable

These bits are set and cleared by software. They enable or disable the PWM output channels independently acting on the corresponding I/O pin.

0: the PWM pin is a general I/O.

1: the PWM pin is driven by the PWM peripheral.

Bits [3:0] = OP[3:0] PWM output polarity

These bits are set and cleared by software. They independently select the polarity of the 4 PWM output signals.

0: positive polarity.

1: negative polarity.

Note: When an OPx bit is modified, the PWMx output signal is immediately updated.

Auto-reload register A (PWMARRA)

Read/Write

Reset Value: 1111 1111(FFh)

7	6	5	4	3	2	1	0
AR73	AR6	AR5	AR4	AR3	AR2	AR1	AR0

Bits [7:0] = AR[7:0] Counter auto-reload data

These bits are set and cleared by software. They are used to hold the auto-reload value which is automatically loaded in the counter when an overflow occurs. Writing in this register reload the PWM counter to ARR A value. At the same time, the PWM output levels are changed according to the corresponding OPx bit in the PWMCR register.

This register adjusts the PWM frequency (setting the PWM duty cycle resolution) for outputs PWM[3:0].

Control register B (PWMCRB)

Read/Write

Reset Value: 0000 0000 (00h)

7	6	5	4	3	2	1	0
0	0	OE5	OE4	0	0	OP5	OP4

Bits [7:6] = Reserved. Forced by hardware to 0

Bits [5:4] = OE[5:4] PWM output enable

These bits are set and cleared by software. They enable or disable the PWM output channels independently acting on the corresponding I/O pin.

0: the PWM pin is a general I/O.

1: the PWM pin is driven by the PWM peripheral.

Bits [3:2] = Reserved. Forced by hardware to 0

Bit [1:0] = OP[5:4] PWM output polarity

These bits are set and cleared by software. They independently select the polarity of the 4 PWM output signals

0: positive polarity.

1: negative polarity.

Note: When an OPx bit is modified, the PWMx output signal is immediately reversed.

Auto-reload register B (PWMARRB)

Read/Write

Reset Value: 1111 1111 (FFh)

7	6	5	4	3	2	1	0
AR73	AR6	AR5	AR4	AR3	AR2	AR1	AR0

Bits [7:0] = AR [7:0] Counter auto-reload data

These bits are set and cleared by software. They are used to hold the auto-reload value which is automatically loaded in the counter when an overflow occurs. Writing in this register reload the PWM counter to ARR B value. At the same time, the PWM output levels are changed according to the corresponding OPx bit in the PWMCR register. This register adjusts the PWM frequency (by setting the PWM duty cycle resolution) for outputs PWM[5:4].



9 8-bit analog-to-digital converter (ADC)

The on-chip Analog to Digital Converter (ADC) peripheral is a 8-bit, successive approximation converter with internal Sample and Hold circuitry. This peripheral has up to 4 multiplexed analog input channels (refer to device pin out description) that allows the peripheral to convert the analog voltage levels from up to 4 different sources.

The result of the conversion is stored in a 8-bit Data Register. The A/D converter is controlled through a Control/Status Register.

Figure 27. ADC block diagram

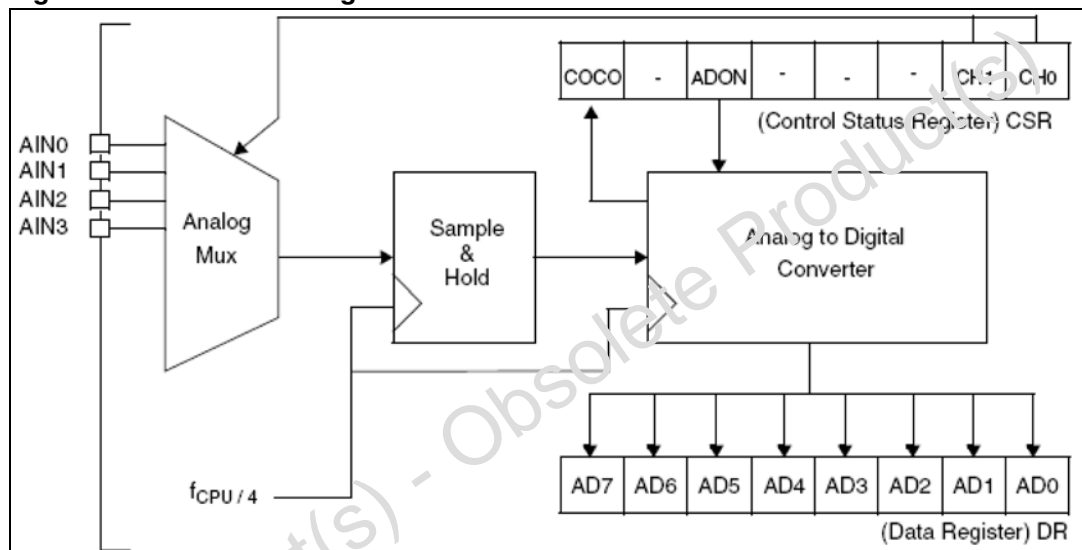

9.1 Main features

- 8-bit conversion
- Up to 4 channels with multiplexed input
- Linear successive approximation
- Data register (DR) which contains the results
- Conversion complete status flag
- On/Off bit (to reduce power consumption)

9.2 Functional description

The high and low level reference voltages are V_{DD} and V_{SS} , respectively. Consequently, conversion accuracy is degraded by voltage drops and noise in the event of heavily loaded or badly decoupled power supply lines.

9.2.1 Characteristics

The conversion is monotonic, the result never decreases or increases if the analog input does not also decrease or increase.

If the input voltage is greater than or equal to VDD (voltage reference high), the results are equal to FFh (full scale) without overflow indication.

If the input voltage is less than or equal to VSS (voltage reference low), the results are equal to 00h. The A/D converter is linear, the digital result of the conversion is given by the formula:

$$\text{Digital result} = \frac{255 \times \text{Input Voltage}}{\text{Supply Voltage}}$$

The conversion accuracy is described in [Section 17](#).

When the A/D converter is continuously “ON”, the conversion time is 16 ADC clock cycles which corresponds to 64 CPU clock cycles.

The internal circuitry is in auto-calibration during the conversion cycle. This process prevents offset drifts. Still, calibration cycles are required at start-up or after any A/D converter re-start.

9.2.2 Procedure

Refer to the CSR and SR registers in [Section 9.3](#) for the bit definitions. At start-up, the A/D converter is OFF (ADON bit equal to ‘0’).

Prior to using the A/D converter, the analog input ports must be configured as inputs (refer to [Section 7](#)). Using these pins as analog inputs does not affect the ability to read the port as a logic input.

Then, the ADON bit must be set to 1. As internal AD circuitry starts calibration, it is mandatory to respect the stabilizing time (several tens of milliseconds) prior to using A/D results.

In the CSR register, bits CH1 to CH0 select the analog channel to be converted (see [Table 20](#)). These bits are set and cleared by software.

The A/D converter performs a continuous conversion of the selected channel.

When a conversion is complete, the COCO bit is set by hardware, but no interrupt is generated. The result is written in the DR register.

Reading the DR result register resets the COCO bit.

Writing to the CSR register aborts the current conversion, the COCO bit is reset and a new conversion is started.

Note: *Resetting the ADON bit disables the A/D converter. Thus, power consumption is reduced when no conversions are needed.*

Note: *The A/D converter is not affected by WAIT mode.*

9.3 Register description

Table 20. ADC register map

Address	Reset		Register	Bit 7	Bit 6	Bit 5	Bit 4	Bit 3	Bit 2	Bit 1	Bit 0
00Ah	00h	R	ADCR	AD[7:0]							
00Bh	00h	R/W	ADCCSR	COCO	0	ADON	0	0	0	0	CH[1:0]

Control/status register (ADCCSR)

Read/Write

Reset Value: (00h)

7	6	5	4	3	2	1	0
COCO	0	ADON	0	0	0	CH1	CH0

Bit 7 = COCO conversion complete

This bit is set by hardware. It is cleared by software by reading the result in the DR register or writing to the CSR register.

0: Conversion is not complete (default)

1: Conversion can be read from the DR register.

Bit 6 = Reserved. This bit must be cleared by software.

Bit 5 = ADON A/D converter On

This bit is set and cleared by software.

0: A/D converter is switched off (default)

1: A/D converter is switched on

Note: Remember that the ADC needs time to stabilize after the ADON bit is set.

Bits [4:2] = Reserved. Forced to 0 by hardware.

Bits [1:0] = CH[1:0] Channel Selection.

These bits are set and cleared by software. They select the analog input to be converted.

Table 21. Channel selection

Pin	CH1	CH0
AIN0 (default)	0	0
AIN1	0	1
AIN2	1	0
AIN3	1	1

DATA register (ADCDR)

Read Only

Reset Value: (00h)

7	6	5	4	3	2	1	0
AD7	AD6	AD5	AD4	AD3	AD2	AD1	AD0

Bits [7:0] = AD[7:0] Analog Converted Value

This register contains the converted analog value in the range 00h to FFh.

Reading this register resets the COCO flag.

10 I²C single-master bus interface

The I²C bus interface serves as an interface between the microcontroller and the serial I²C bus. It provides single-master functions, and controls all I²C bus-specific sequencing, protocol and timing. It supports fast I²C mode (400 kHz) and up to 800 kHz for certain applications.

10.1 Main features

- Parallel / I²C bus protocol converter
- Interrupt generation
- Standard I²C mode/Fast I²C mode (up to 800 kHz for certain applications)
- 7-bit addressing

I²C Single master mode

- End of byte transmission flag
- Transmitter /Receiver flag
- Clock generation

10.2 General description

In addition to receiving and transmitting data, this interface converts data from serial to parallel format and vice versa, using either an interrupt or a polled handshake. The interrupts are enabled or disabled by software. The interface is connected to the I²C bus by a data pin (SDAI) and by a clock pin (SCLI). It can be connected both with a standard I²C bus and a Fast I²C bus. This selection is made by software.

Mode selection

The interface can operate in the two following modes:

1. Master transmitter/receiver,
2. Idle (default).

The interface automatically switches from Idle to Master mode after it generates a START condition and from Master to Idle mode after it generates a STOP condition.

Communication flow

The interface initiates a data transfer and generates the clock signal. A serial data transfer always begins with a start condition and ends with a stop condition. Both start and stop conditions are generated by software.

Data and addresses are transferred as 8-bit bytes, MSB first. The first byte following the start condition is the address byte.

A 9th clock pulse follows the 8 clock cycles of a byte transfer, during which the receiver must send an acknowledge bit to the transmitter (see [Figure 28](#)).

Acknowledge is enabled and disabled by software.

The speed of the I²C interface is selected as standard (0 to 100 kHz) and fast I²C (100 to 400 kHz) and up to 800 kHz for certain applications.

Figure 28. I²C bus protocol

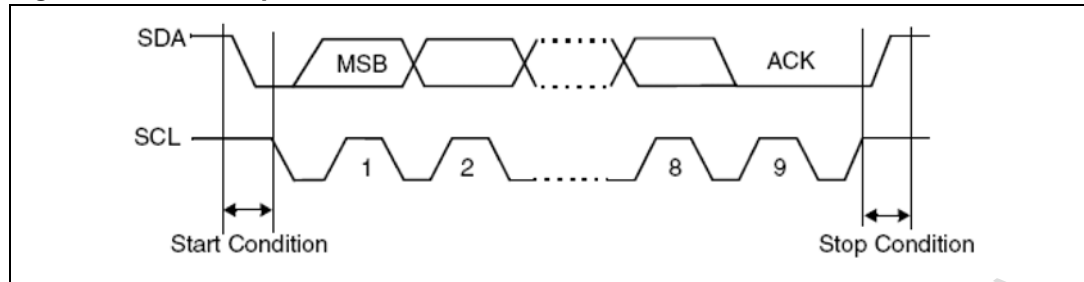

SDA/SCL line control

Transmitter mode: The interface holds the clock line low before transmission to wait for the microcontroller to write the byte in the data register.

Receiver mode: The interface holds the clock line low after reception to wait for the microcontroller to read the byte in the data register.

The SCL frequency (f_{SCL}) is controlled by a programmable clock divider which depends on the I²C bus mode.

When the I²C cell is enabled, the SDA and SCL ports must be configured as a floating open-drain output or a floating input. In this case, the value of the external pull-up resistor used depends on the application.

When the I²C cell is disabled, the SDA and SCL ports revert to being standard I/O port pins.

Figure 29. I²C interface block diagram

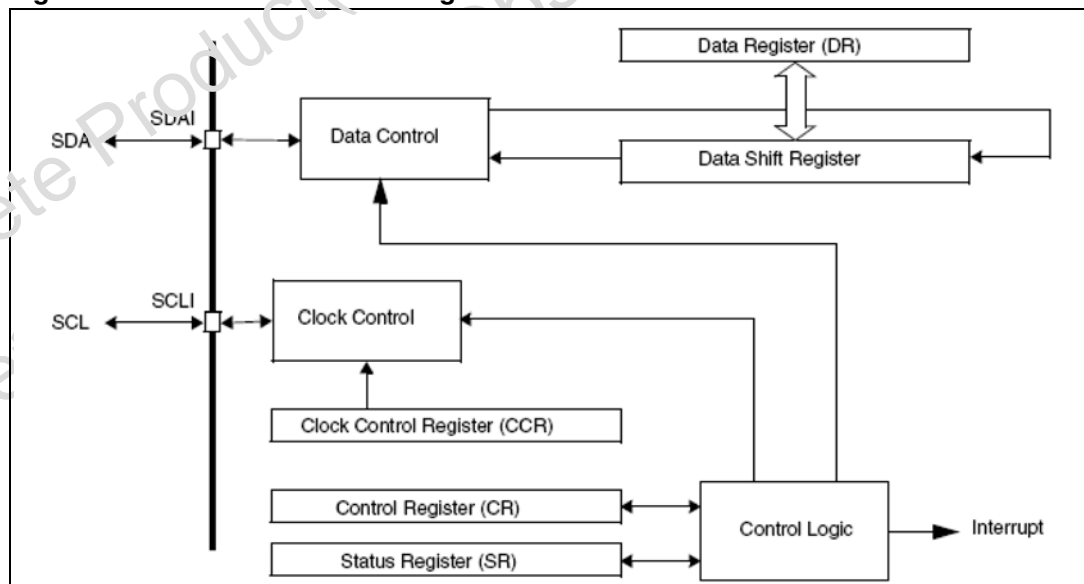

10.3 Functional description (master mode)

By default, the I²C interface operates in Idle mode (M/IDL bit is cleared) except when it initiates a transmit or receive sequence.

To switch from default Idle mode to master mode a start condition must be generated.

Setting the START bit causes the interface to switch to master mode (M/IDL bit set) and generates a start condition.

Once the start condition is sent, the EVF and SB bits are set by hardware and an interrupt is generated if the ITE bit is set.

Then the master waits for a read of the SR register followed by a write in the DR register with the slave address byte, holding the SCL line low (EV1).

Then the slave address byte is sent to the SDA line via the internal shift register.

After completion of this transfer (and the reception of an acknowledge from the slave if the ACK bit is set), the EVF bit is set by hardware and an interrupt is generated if the ITE bit is set.

Then the master waits for a read of the SR register followed by a write in the CR register (for example set PE bit), holding the SCL line low (EV2).

Next the master must enter receiver or transmitter mode.

10.4 Transfer sequencing

10.4.1 Master receiver

Following the address transmission and after SR and CR registers have been accessed, the master receives bytes from the SDA line into the DR register via the internal shift register. After each byte the interface generates in sequence:

- an Acknowledge pulse if the ACK bit is set
- EVF and BTF bits are set by hardware with an interrupt if the ITE bit is set

Then the interface waits for a read of the SR register followed by a read of the DR register, holding the SCL line low (EV3).

To close the communication, before reading the last byte from the DR register, set the STOP bit to generate the stop condition. The interface automatically returns to Idle mode (M/IDL bit cleared).

Note: In order to generate the non-acknowledge pulse after the last received data byte, the ACK bit must be cleared just before reading the second last data byte.

10.4.2 Master transmitter

Following the address transmission and after SR register has been read, the master sends bytes from the DR register to the SDA line via the internal shift register.

The master waits for a read of the SR register followed by a write in the DR register, holding the SCL line low (EV4).

When the acknowledge bit is received, the interface sets the EVF and BTF bits with an interrupt if the ITE bit is set.

To close the communication, after writing the last byte to the DR register, set the STOP bit to generate the stop condition. The interface automatically returns to idle mode (M/IDL bit cleared).

Error case:

AF: Detection of a non-acknowledge bit. In this case, the EVF and AF bits are set by hardware with an interrupt if the ITE bit is set. To resume, set the START or STOP bit.

Note: The SCL line is not held low if AF = 1.

Figure 30. Transfer sequencing

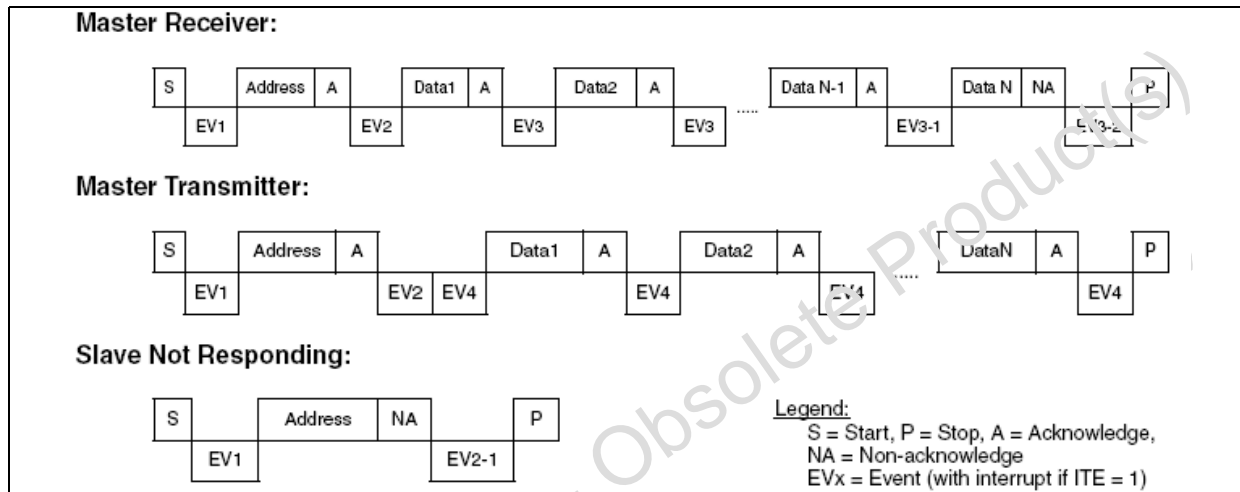

EV1: EVF = 1, SB = 1, cleared by reading the SR register followed by writing to the DR register.

EV2: EVF = 1, cleared by reading the SR register followed by writing to the CR register (for example PE = 1).

EV2-1: EVF = 1, AF = 1, cleared by reading the SR register followed by writing STOP = 1 in the CR register.

EV3: EVF = 1, BTF = 1, cleared by reading the SR register followed by reading the DR register.

EV3-1: Same as EV3, but ACK bit in CR register must be cleared before reading the DR register in order to send a NAK pulse after the "Data N" byte.

EV3-2: Same as EV3, but STOP = 1 must be written in the CR register.

EV4: EVF = 1, BTF = 1, cleared by reading the SR register followed by writing to the DR register.

Figure 31. Event flags and interrupt generation

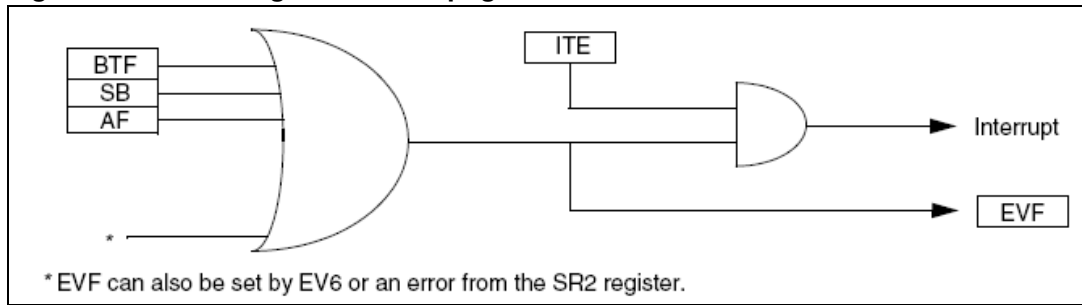

10.5 Register description

Table 22. I²C register map

Address	Reset		Register	Bit 7	Bit 6	Bit 5	Bit 4	Bit 3	Bit 2	Bit 1	Bit 0
001Ch	00h	R/W	I2CCR	00		PE	0	START	ACK	STOP	ITE
001Dh	00h	R	I2CSR	EVF	AF	TRA	0	BTF	0	M/IDL	SB
001Eh	00h	R/W	I2CCCR	FM/SM	FILT OFF	CC[5:0]					
001Fh	00h	R/W	I2CDR	DR[7:0]							

I²C control register (I2CCR)

Read / Write

Reset Value: 0000 0000 (00h)

7	6	5	4	3	2	1	0
0	0	PE	0	START	ACK	STOP	ITE

Bits [7:6] = **Reserved**. Forced to 0 by hardware.

Bit 5 = PE Peripheral enable.

This bit is set and cleared by software.

0: Peripheral disabled

1: Master capability

Note: When PE = 0, all the bits of the CR register and the SR register except the Stop bit are reset. All outputs are released when PE = 0.

When PE = 1, the corresponding I/O pins are selected by hardware as alternate functions. To enable the I²C interface, write the CR register **TWICE** with PE = 1 as the first write only activates the interface (only PE is set).

Bit 4 = Reserved. Forced to 0 by hardware

Bit 3 = START *Generation of a start condition.* This bit is set and cleared by software. It is also cleared by hardware when the interface is disabled (PE = 0) or when the start condition is sent (with interrupt generation if ITE = 1).

In Master mode:

0: No start generation

1: Repeated start generation

In Idle mode:

0: No start generation

1: Start generation when the bus is free

Bit 2 = ACK *Acknowledge enable.*

This bit is set and cleared by software. Cleared by hardware when the interface is disabled (PE = 0).

0: No acknowledge returned

1: Acknowledge returned after an address byte or a data byte is received

Bit 1 = STOP *Generation of a stop condition.*

This bit is set and cleared by software. It is also cleared by hardware when the interface is disabled (PE = 0) or when the stop condition is sent (in master mode only).

0: No stop generation

1: Stop generation after the current byte transfer or after the current start condition is sent.

Bit 0 = ITE *Interrupt enable.*

This bit is set and cleared by software and cleared by hardware when the interface is disabled (PE = 0).

0: Interrupt disabled

1: Interrupt enabled

I2C status register (I2CSR)

Read Only

Reset Value: 0000 0000 (00h)

7	6	5	4	3	2	1	0
EVF	AF	TRA	0	BTF	0	M/IDL	SB

Bit 7 = EVF *Event flag.*

This bit is set by hardware as soon as an event occurs. It is cleared by software by reading the SR register in case of error event or as described in [Section 10.5: Transfer Sequencing](#). It is also cleared by hardware when the interface is disabled (PE = 0).

0: No event

1: One of the following events has occurred:

BTF = 1 (Byte received or transmitted)

SB = 1 (Start condition generated)

AF = 1 (No acknowledge received after byte transmission if ACK = 1)

Address byte successfully transmitted.

Bit 6 = AF Acknowledge Failure.

This bit is set by hardware when no acknowledge is returned. An interrupt is generated if ITE = 1. It is cleared by software by reading the SR register or by hardware when the interface is disabled (PE = 0).

The SCL line is not held low when AF = 1.

0: No acknowledge failure

1: Acknowledge failure

Bit 5 = TRA *Transmitter/Receiver.*

When BTF is set, TRA = 1 if a data byte has been transmitted. It is cleared automatically when BTF is cleared. It is also cleared by hardware when the interface is disabled (PE = 0).

0: Data byte received (if BTF = 1)

1: Data byte transmitted

Bit 4 = Reserved. *Forced to 0 by hardware.*

Bit 3 = BTF *Byte transfer finished.*

This bit is set by hardware as soon as a byte is correctly received or transmitted with interrupt generation if ITE = 1. It is cleared by software by reading the SR register followed by a read or write of DR register. It is also cleared by hardware when the interface is disabled (PE = 0).

Following a byte transmission, this bit is set after reception of the acknowledge clock pulse. In case an address byte is sent, this bit is set only after the EV2 event (See [Section 10.4](#)). BTF is cleared by reading SR register followed by writing the next byte in DR register.

Following a byte reception, this bit is set after transmission of the acknowledge clock pulse if ACK = 1. BTF is cleared by reading SR register followed by reading the byte from DR register.

The SCL line is held low when BTF = 1.

0: Byte transfer not done

1: Byte transfer succeeded

Bit 2 = Reserved. *Forced to 0 by hardware.*

Bit 1 = M/IDL *Master/Idle.*

This bit is set by hardware when the interface is in master mode (writing START = 1). It is cleared by hardware after a stop condition on the bus. It is also cleared by hardware when the interface is disabled (PE = 0).

0: Idle mode

1: Master mode

Bit 0 = SB *Start bit.*

This bit is set by hardware when a start condition is generated (following a write START = 1). An interrupt is generated if ITE = 1. It is cleared by software by reading the SR register

followed by writing the address byte in DR register. It is also cleared by hardware when the interface is disabled (PE = 0).

0: No start condition

1: Start condition generated

I2C clock control register (I2CCCR)

Read / Write

Reset Value: 0000 0000 (00h)

7	6	5	4	3	2	1	0
FM/SM	FILTOFF	CC5	CC4	CC3	CC2	CC1	CC0

Bit 7 = FM/SM Fast/Standard I2C mode.

This bit is set and cleared by software. It is not cleared when the interface is disabled (PE = 0).

0: Fast I2C mode

1: Standard I2C mode

Bit 6 = FILTOFF Filter off.

This bit is set and cleared by software, it is not taken into account in the EMU version and is considered as always set to 1 (inactive filter).

When set, it disables the filter of the I2C pads in order to achieve speeds of over 400 kHz on a shortlength I2C bus (at the user's responsibility). Such high frequencies are computed with the fast mode formula given below.

Bits [5:0] = CC[5:0] 6-bit clock divider.

These bits select the speed of the bus (fSCL) depending on the I2C mode. They are not cleared when the interface is disabled (PE = 0). The value of the 6-bit clock divider, CC[5:0], 03h

Fast mode (FM/SM = 0): $f_{SCL} > 100 \text{ kHz}$

$$f_{SCL} = f_{CPU} / ([2x([CC5...CC0]+3)]+1)$$

Standard mode (FM/SM = 1): $f_{SCL} \leq 100 \text{ kHz}$

$$f_{SCL} = f_{CPU} / (3x([CC5...CC0]+3))$$

Note: The programmed f_{SCL} speed assumes that there is no load on the SCL and SDA lines.

I2C data register (I2CDR)

Read / Write

Reset Value: 0000 0000 (00h)

7	6	5	4	3	2	1	0
D7	D6	D5	D4	D3	D2	D1	D0

Bits [7:0] = D[7:0] 8-bit data register.

These bits contain the byte to be received or transmitted on the bus.

Transmitter mode: Bytes are automatically transmitted when the software writes to the DR register.

Receiver mode: The first data byte is automatically received in the DR register using the least significant bit of the address.

Then, the subsequent data bytes are received one-by-one after reading the DR register.

Obsolete Product(s) - Obsolete Product(s)
Obsolete Product(s) - Obsolete Product(s)

11 Display data channel interfaces (DDC)

The DDC (Display Data Channel) bus interfaces are mainly used by the monitor to identify itself to the video controller, by the monitor manufacturer to perform factory alignment, and by the user to adjust the monitor's parameters. Both DDC interfaces consist of:

- A fully hardware-implemented interface, supporting DDC2B (VESA specification 3.0 compliant). It accesses the ST7 on-chip memory directly through a built-in DMA engine.
- A second interface, supporting the slave I²C functions for handling DDC/CI mode (DDC2Bi), factory alignment, HDCP, Enhanced DDC (EDDC) or other addresses by software.

Each DDC interface has its own dedicated DMA area in RAM. In the event of concurrent DMA accesses, the DDC A cell has priority over the DDC B cell.

11.1 DDC interface features

11.1.1 Hardware DDC2B interface features

- Full hardware support for DDC2B communications (VESA specification version 3)
- Hardware detection of DDC2B addresses ACh/A1h
- Separate mapping of EDID version 1: Base (128 bytes) and Extended (128 bytes)
- Support for error recovery mechanism
- Detection of misplaced start and stop conditions
- Random and sequential I²C byte read modes
- DMA transfer from any memory location and to RAM
- Automatic memory address increment
- End of data downloading flag, end of communication flag and interrupt capability

11.1.2 DDC/CI factory interface features

General I²C features

- Parallel bus /I²C protocol converter
- Interrupt generation
- Standard I²C mode
- 7-bit Addressing

I²C slave features

- I²C bus busy flag
- Start bit detection flag
- Detection of misplaced start or stop condition
- Transfer problem detection
- Address matched detection
- 2 programmable address detection and/or Hardware detection of DDC/CI addresses (6Eh/6Fh)
- End of byte transmission flag
- Transmitter/receiver flag
- Stop condition detection

Figure 32. DDC interface overview

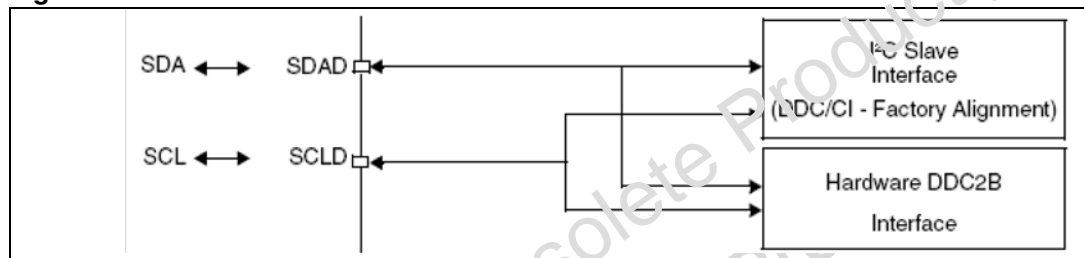
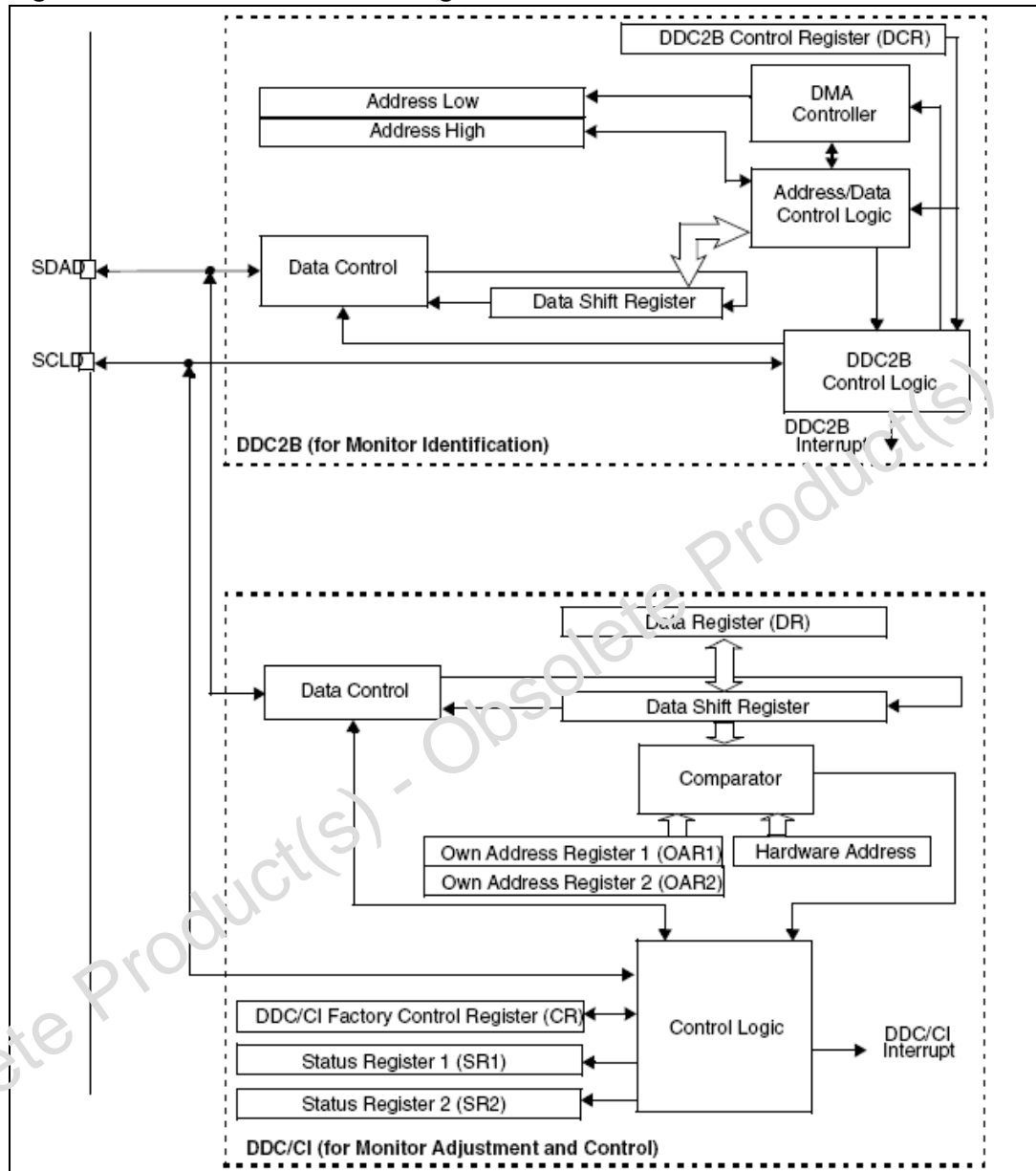

Figure 33. DDC interface block diagram



11.2 Signal description

11.2.1 Serial data (SDA)

The SDA bidirectional pin is used to transfer data in and out of the device. An external pull-up resistor must be connected to the SDA line. Its value depends on the load of the line and the transfer rate.

11.2.2 Serial clock (SCL)

The SCL input pin is used to synchronize all data in and out of the device when in I²C bidirectional mode. An external pull-up resistor must be connected to the SCL line. Its value depends on the load of the line and the transfer rate.

Note: When the DDC2B and DDC/CI factory interfaces are disabled (HWPE bit = 0 in the DCR register and PE bit = 0 in the CR register), the SDA and SCL pins revert to being standard I/O pins.

11.3 DDC standard

The DDC standard is divided into several data transfer protocols: DDC2B, DDC/CI and other slave communication standards (HDCP, E-DDC, etc.).

For DDC2B, refer to the “VESA DDC Standard v3.0” specification. For DDC/CI refer to the “VESA DDC Commands Interface v1.0”

DDC2B is a unidirectional channel from display to host. The host computer uses base-level I²C commands to read the EDID data from the display which is always in Slave mode.

DDC/CI is a bidirectional channel between the host computer and the display. The DDC/CI offers a display control interface based on I²C bus. Only the DDC2Bi interface is supported (and not the DDC2B+ or DDC2AB interfaces).

11.3.1 DDC2B interface

The DDC2B Interface acts as an I/O interface between a DDC bus and the MCU memory. In addition to receiving and transmitting serial data, this interface directly transfers parallel data to and from memory using a DMA engine, only halting CPU activity for 2 clock cycles during each byte transfer.

The interface supports the following by hardware:

- DDC2B communication protocol
- write operations into RAM
- read operations from RAM

In DDC2B mode, it operates in I²C slave mode.

Device addresses A0h/A1h are recognized. EDID version 1 is used.

The Write and Read operations allow the EDID data to be downloaded during factory alignment (for example).

Writing to the memory by the DMA engine is inhibited by the WP bit in the DCR register. A write of the last data structure byte sets a flag and may be programmed to generate an interrupt request.

The data address (sub-address) is either the second byte of write transfers or is pointed to by the internal address counter which automatically increments after each byte transfer. The physical address mapping of the data structure is fixed by hardware in a dedicated RAM area (see [Table 25](#)).

11.3.2 Mode description

DDC2B mode: The DDC2B interface enters DDC2B mode from the initial state if the software sets the HWPE bit. Once in DDC2B mode, the interface always acts as a slave following the protocol described in [Figure 34](#).

The DDC2B interface continuously monitors the SDA and SCL lines for a start condition and will not respond (no acknowledge) until one is found.

A stop condition at the end of a read command (after a NACK) forces the stand-by state. A stop condition at the end of a write command triggers the internal DMA write cycle.

The interface samples the SDA line on the rising edge of the SCL signal and outputs data on the falling edge of the SCL signal. In any case, the SDA line can only change when the SCL line is low.

Figure 34. DDC2B protocol example

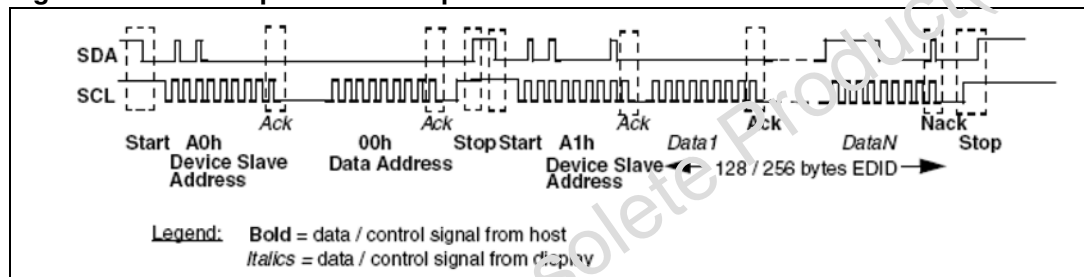
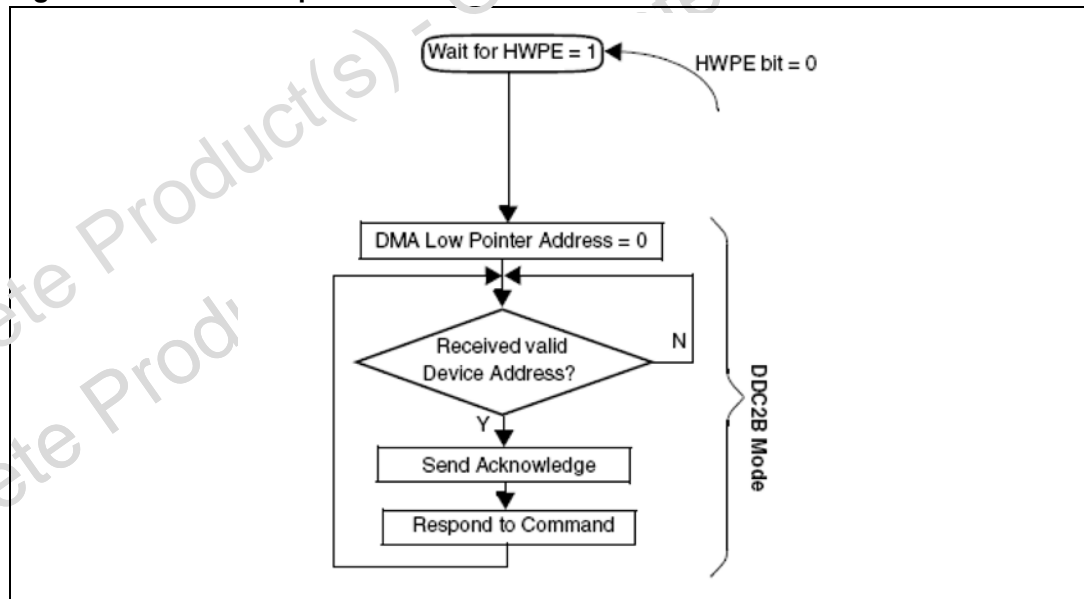

Figure 35. DDC1/2B operation flow chart



EDID data structure mapping: An internal address pointer defines the memory location being addressed.

It defines the 256-byte block within the RAM address space containing the data structure. The LSB is loaded with the data address sent by the master after a write device address. It defines the byte within the data structure currently addressed. It is reset upon entry into the DDC2B mode.

Figure 36. Mapping of DDC2B data structure

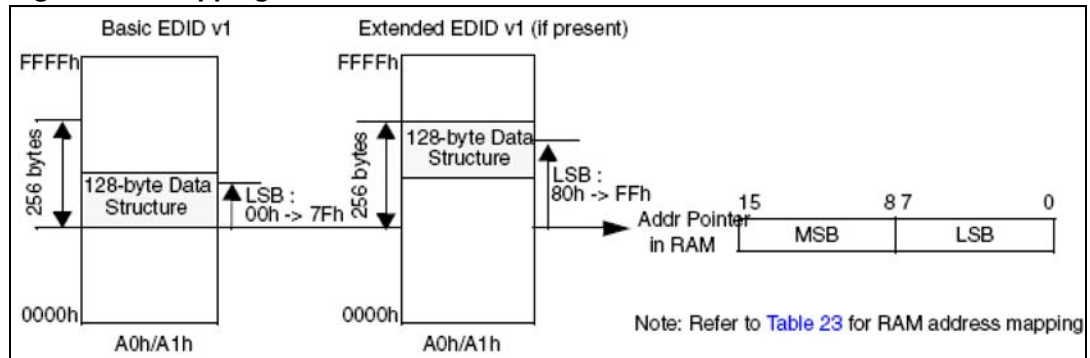

Write operation

Once the DDC2B Interface has acknowledged a write transfer request, i.e. a device address with RW = 0, it waits for a data address. When the latter is received, it is acknowledged and loaded into the LSB.

Then, the master may send any number of data bytes that are all acknowledged by the DDC2B interface. The data bytes are written in RAM if the WF-bit = 0 in the DCR register, otherwise the RAM location is not modified.

Write operations are always performed in RAM and therefore do not delay DDC transfers. Meanwhile, concurrent software execution is halted for 2 clock cycles.

Figure 37. Write sequence

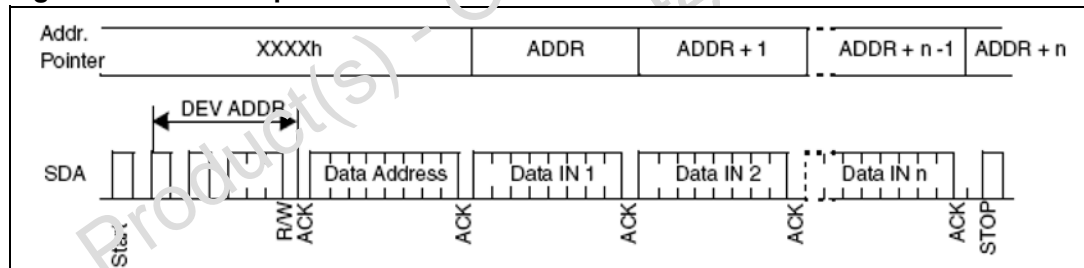

Read operations

All read operations consist of retrieving the data pointed to by an internal address counter which is initialized by a dummy write and which increments with any read. The DDC2B interface always waits for an acknowledge during the 9th bit-time. If the master does not pull the SDA line low during this bit-time, the DDC2B interface ends the transfer and switches to a stand-by state.

Current address read: After generating a start condition the master sends a read device address (RW = 1). The DDC2B Interface acknowledges this and outputs the data byte pointed to by the internal address pointer which subsequently increments. The master must NOT acknowledge this byte and must terminate the transfer with a stop condition.

Random address read: The master performs a dummy write to load the data address into the pointer LSB. Then the master sends a restart condition followed by a read device address (RW = 1).

Sequential address read: This mode is similar to the current and random address reads, except that the master DOES acknowledge the data byte for the DDC2B Interface to output

the next byte in sequence. To terminate the read operation the master must NOT acknowledge the last data byte and must generate a stop condition. The data output are issued from consecutive memory addresses.

End of communication: Upon a detection of NACK or stop conditions at the end of a read transfer, the bit ENDCF is set and an interrupt is generated if ENDCE is set.

Figure 38. Read sequences

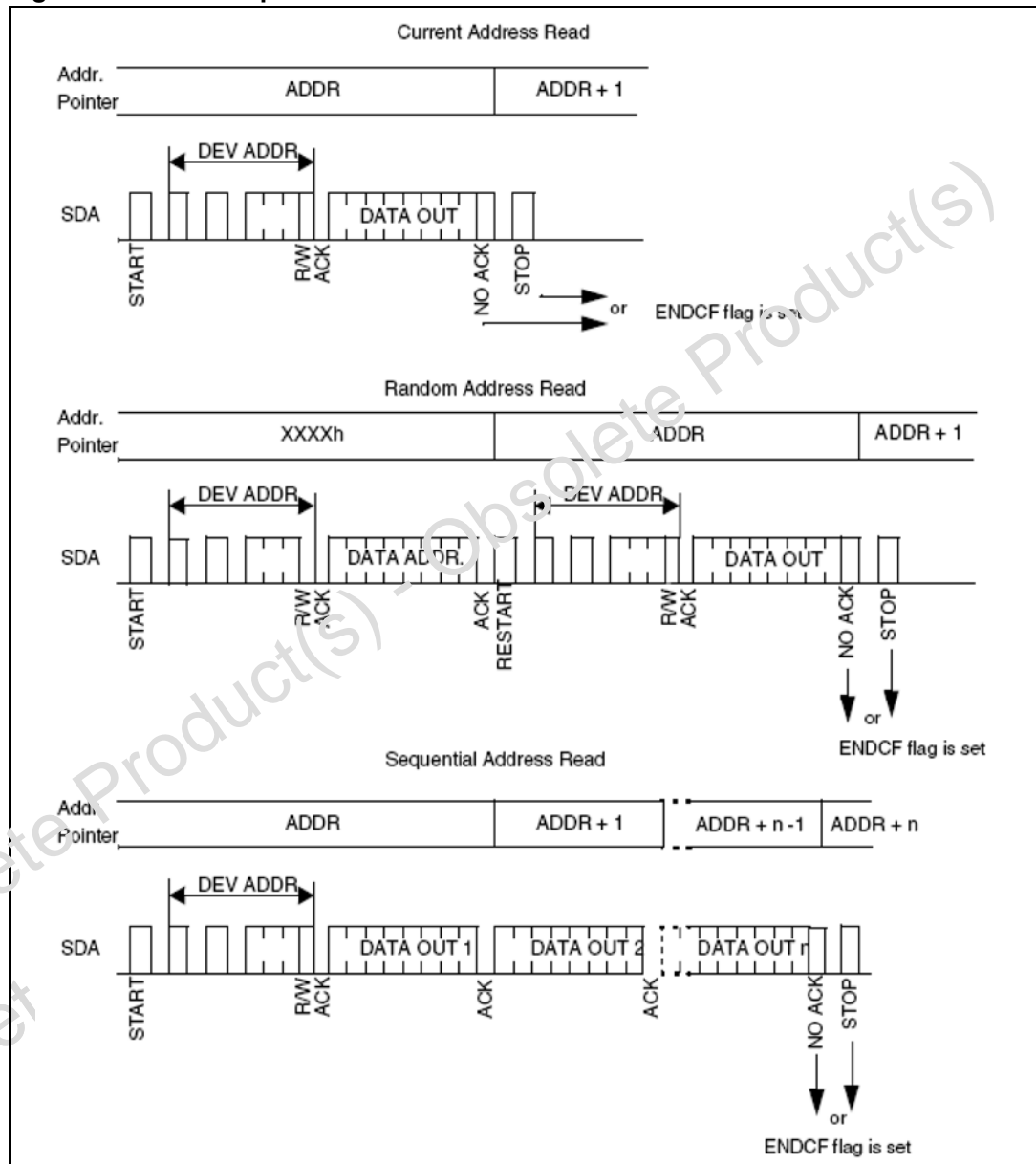

Read and write operations

After each byte transfer, the internal address counter automatically increments. If the counter is pointing to the top of the structure, it rolls over to the bottom since the increment is performed only on the 7 or 8 LSBs of the pointer depending on the selected data structure

size. It rolls over from 7Fh to 00h or from FFh to 80h depending on the MSB of the last data address received.

Then after that last byte has been effectively written or read in RAM at LSB address 7Fh or FFh, the EDF flag is set and an interrupt is generated if EDE is set.

The transfer is terminated by the master generating a stop condition.

11.4 DDC/CI factory alignment interface

Refer to the CR, SR1 and SR2 registers in [Section 11.6](#) for the bit definitions.

The DDC/CI interface works as an I/O interface between the microcontroller and the DDC2Bi, HDCP, E-DDC or factory alignment protocols. It receives and transmits data in Slave I²C mode using an interrupt or polled handshaking.

The interface is connected to the I²C bus through a data pin (SDAD) and a clock pin (SCLD) configured as an open-drain output.

The DDC/CI interface has five internal register locations. Two of them are used to initialize the interface:

1. Two own address registers OAR1 and OAR2
2. Control register CR

The following four registers are used during data transmission/reception:

1. Data register DR
2. Control register CR
3. Status register 1 SR1
4. Status register 2 SR2

The interface decodes an I²C or DDC2Bi address stored by software in either OAR register and/or the DDC/CI address (6Eh/6Fh) as its default hardware address.

After a reset the interface is disabled.

11.4.1 I²C modes

The interface operates in slave transmitter/receiver modes.

The master generates both start and stop conditions. The I²C clock (SCL) is always received by the interface from a master, but the interface is able to stretch the clock line.

The interface can recognize its two programmable addresses (7-bit) and its default hardware address (DDC/CI address: 6Eh/6Fh). The DDC/CI address detection may be enabled or disabled by software. It never recognizes the start byte (01h) whatever its own address is.

Slave mode

As soon as a start condition is detected, the address is received from the SDA line and sent to the shift register where it is compared to the programmable addresses or to the DDC/CI address (if selected by software).

Address not matched: the interface ignores it and waits for another start condition.

Address matched: the following events occur in sequence:

- Acknowledge pulse is generated if the ACK bit is set
- EVF and ADSL bits are set
- An interrupt is generated if the ITE bit is set.

Then the interface waits for a read of the SR1 register, holding the SCL line low (see EV1 in [Section 11.5](#)). Next, the DR register must be read to determine from the least significant bit if the slave must enter receiver or transmitter mode.

Slave receiver

Following the address reception and after SR1 register has been read, the slave receives bytes from the SDA line into the DR register via the internal shift register. After each byte, the following events occur in sequence:

- Acknowledge pulse is generated if the ACK bit is set
- the EVF and BTF bits are set
- an interrupt is generated if the ITE bit is set

Then the interface waits for a read of the SR1 register followed by a read of the DR register, holding the SCL line low (see EV2 in [Section 11.5](#)).

Slave transmitter

Following the address reception and after SR1 register has been read, the slave sends bytes from the DR register to the SDA line via the internal shift register.

The slave waits for a read of the SR1 register followed by a write in the DR register, holding the SCL line low (see EV3 in [Section 11.5](#)).

When the acknowledge pulse is received:

- the EVF and BTF bits are set
- an interrupt is generated if the ITE bit is set.

Closing slave communication

After the last data byte is transferred, a stop condition is generated by the master. The interface detects this condition and in this case:

- the EVF and STOPF bits are set
- an interrupt is generated if the ITE bit is set.

Then the interface waits for a read of the SR2 register (see EV4 in [Section 11.5](#)).

Error cases

BERR: Detection of a stop or a start condition during a byte transfer. In this case, the EVF and the BERR bits are set and an interrupt is generated if the ITE bit is set.

If it is a stop condition, then the interface discards the data, releases the lines and waits for another start condition. If it is a start condition, then the interface discards the data and waits for the next slave address on the bus.

AF: Detection of a non-acknowledge bit. In this case, the EVF and AF bits are set and an interrupt is generated if the ITE bit is set.

Note: In both cases, the SCL line is not held low. However, the SDA line can remain low due to possible '0' bits transmitted last. It is then necessary to release both lines by software.

How to release the SDA / SCL Lines

Set and subsequently clear the stop bit when BTF is set. The SDA/SCL lines are released after the transfer of the current byte.

Other events

ADSL: Detection of a start condition after an acknowledge time-slot. The state machine is reset and starts a new process. The ADSL bit is set and an interrupt is generated if the ITE bit is set. The SCL line is stretched low.

STOPF: Detection of a stop condition after an acknowledge time-slot. The state machine is reset. Then the STOPF flag is set and an interrupt is generated if the ITE bit is set.

11.5 Transfer sequencing

Figure 39. Transfer sequencing

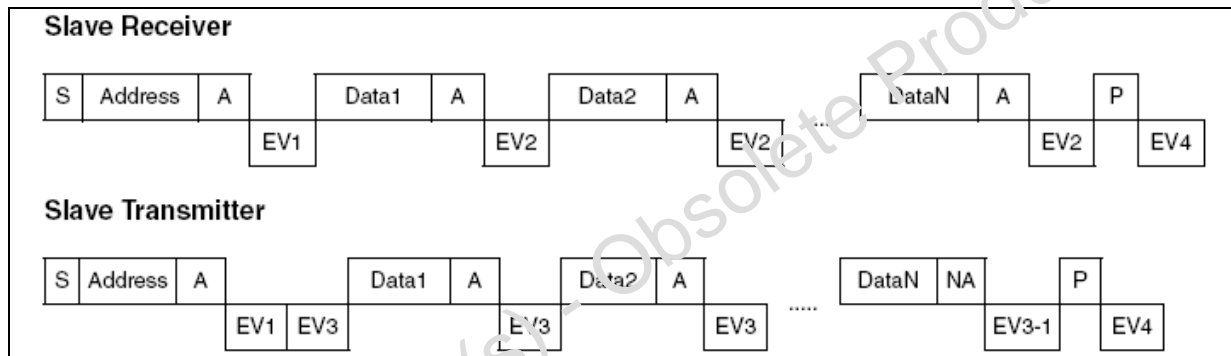

Legend:

S = Start, P = Stop, A = Acknowledge, NA = Non-acknowledge and EVx = Event (with interrupt if ITE = 1)

EV1: EVF = 1, ADSL = 1, cleared by reading register SR1.

EV2: EVF = 1, BTF = 1, cleared by reading register SR1 followed by reading DR register.

EV3: EVF = 1, BTF = 1, cleared by reading register SR1 followed by writing DR register.

EV3-1: EVF = 1, AF = 1 and BTF = 1, AF is cleared by reading register SR2, BTF is cleared by releasing the lines (write STOP = 1, STOP = 0 in register CR) or by writing to register DR (DR = FFh).

Note: If the lines are released by STOP = 1, STOP = 0, the subsequent EV4 is not seen.

EV4: EVF = 1, STOPF = 1, cleared by reading register SR2.

Figure 40. Events flag and interrupt generation

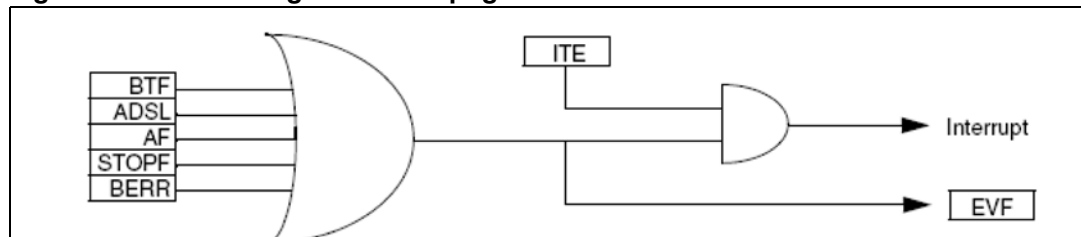

11.6 Register description

Table 23. DDCA register map

Address	Reset		Register	bit 7	bit 6	bit 5	bit 4	bit 3	bit 2	bit 1	bit 0
0020h	00h	R/W	DDCCRA	0	0	PE	DDCIEN	0	ACK	STOP	ITE
0021h	00h	R	DDCSR1A	EVF	0	TRA	BUSY	BTF	ADSL	0	0
0022h	00h	R	DDCSR2A	0	0	0	AF	STOPF	0	BERR	DDCIF
0023h	00h	R/W	DDCOAR1A	ADD[7:0]							
0024h	00h	R/W	DDCOAR2A	ADD[7:0]							
0025h	00h	R/W	DDCDRA	DR[7:0]							
0026h	00h	R/W	Reserved								
0027h	00h	R/W	DDCDCRA	0	0	ENDCF	ENDCE	EDF	EDE	WP	HWPE

Table 24. DDCB register map

Address	Reset		Register	bit 7	bit 6	bit 5	bit 4	bit 3	bit 2	bit 1	bit 0
0028h	00h	R/W	DDCCRB	0	0	PE	DDCIEN	0	ACK	STOP	ITE
0029h	00h	R	DDCSR1B	EVF	0	TRA	BUSY	BTF	ADSL	0	0
002Ah	00h	R	DDCSR2B	0	0	0	AF	STOPF	0	BERR	DDCIF
002Bh	00h	R/W	DDCOAR1B	ADD[7:0]							
002Ch	00h	R/W	DDCOAR2B	ADD[7:0]							
002Dh	00h	R/W	DDCDRB	DR[7:0]							
002Eh	00h	R/W	Reserved								
002Fh	00h	R/W	DDCDCRB	0	0	ENDCF	ENDCE	EDF	EDE	WP	HWPE

Table 25. EDID DMA pointer configuration

Cell	Basic EDID	Extended EDID
DDCA	600h...67Fh	680h...6FFh
DDCB	700h...77Fh	780h...7FFh

DDC control register (DDCCR)

Read / Write

Reset Value: 0000 0000 (00h)

7	6	5	4	3	2	1	0
0	0	PE	DDCIEN	0	ACK	STOP	ITE

Bit [7:6] = Reserved. Forced to 0 by hardware.

Bit 5 = **PE Peripheral enable**. This bit is set and cleared by software.

0: Peripheral disabled

1: Slave capability

Note: When PE=0, all the bits of the CR register and the SR register are reset. All outputs are released while PE=0

When PE=1, the corresponding I/O pins are selected by hardware as alternate functions. To enable the I²C interface, write the CR register **TWICE** with PE=1 as the first write only activates the interface (only PE is set).

Bit 4 = DDCIEN DDC/CI address detection enabled. This bit is set and cleared by software. It is also cleared by hardware when the interface is disabled (PE=0). The 6Eh/6Fh DDC/CI address is acknowledged.

0: DDC/CI address detection disabled

1: DDC/CI address detection enabled

Bit 3 = Reserved. Forced to 0 by hardware.

Bit 2 = ACK Acknowledge enable. This bit is set and cleared by software. It is also cleared by hardware when the interface is disabled (PE=0).

0: No acknowledge returned

1: Acknowledge returned after an address byte or a data byte is received

Bit 1 = STOP Release I2C bus. This bit is set and cleared by software or when the interface is disabled (PE=0).

Slave mode:

0: Nothing

1: Release the SCL and SDA lines after the current byte transfer (BTF=1). The STOP bit has to be cleared by software.

Bit 0 = INT Interrupt enable. This bit is set and cleared by software and cleared by hardware when the interface is disabled (PE=0).

0: Interrupts disabled

1: Interrupts enabled

Refer to [Figure 40](#) for the relationship between the events and the interrupt.

SCL is held low when the BTF or ADSL is detected.

DDC status register 1 (DDCSR1)

Read Only

Reset Value: 0000 0000 (00h)

7	6	5	4	3	2	1	0
EVF	0	TRA	BUSY	BTF	ADSL	0	0

Bit 7 = EVF Event flag. This bit is set by hardware as soon as an event occurs. It is cleared by software reading SR2 register in case of error event or as described in [Figure 40](#). It is also cleared by hardware when the interface is disabled (PE=0).



0: No event

1: One of the following events has occurred:

- BTF=1 (Byte received or transmitted)
- ADSL=1 (Either address matched in slave mode while ACK=1)
- AF=1 (No acknowledge received after byte transmission if ACK=1)
- STOPF=1 (Stop condition detected in slave mode)
- BERR=1 (Bus error, misplaced start or stop condition detected)

Bit6 = Reserved. Forced to 0 by hardware.

Bit 5 = TRA Transmitter/Receiver. When BTF is set, TRA=1 if a data byte has been transmitted. It is cleared automatically when BTF is cleared. It is also cleared by hardware after detection of stop condition (STOPF=1) or when the interface is disabled (PE=0).

0: Data byte received (if BTF=1)

1: Data byte transmitted

Bit 4 = BUSY Bus busy. This bit is set by hardware on detection of a start condition and cleared by hardware on detection of a stop condition. It indicates a communication in progress on the bus. This information is still updated when the interface is disabled (PE=0).

0: No communication on the bus

1: Communication ongoing on the bus

Bit 3 = BTF Byte transfer finished. This bit is set by hardware as soon as a byte is correctly received or transmitted with interrupt generation if ITE=1. It is cleared by software reading SR1 register followed by a read or write of DR register. It is also cleared by hardware when the interface is disabled (PE=0).

Following a byte transmission, this bit is set after reception of the acknowledge clock pulse BTF is cleared by reading SR1 register followed by writing the next byte in DR register.

Following a byte reception, this bit is set after transmission of the acknowledge clock pulse if ACK=1 BTF is cleared by reading SR1 register followed by reading the byte from DR register.

The SCL line is held low while BTF=1.

0: Byte transfer not done

1: Byte transfer succeeded

Bit 2 = ADSL Address matched (slave mode). This bit is set by hardware as soon as the received slave address matched with the OARx registers content or the DDC/CI address is recognized. An interrupt is generated if ITE=1. It is cleared by software reading SR1 register or by hardware when the interface is disabled (PE=0).

The SCL line is held low while ADSL=1.

0: Address mismatched or not received

1: Received address matched

Bit 1:0 = Reserved. Forced to 0 by hardware.

DDC status register 2 (DDCSR2)

Read Only

Reset Value: 0000 0000 (00h)

7	6	5	4	3	2	1	0
0	0	0	AF	STOPF	0	BERR	DDCIF

Bit [7:5] = Reserved. Forced to 0 by hardware.

Bit 4 = AF Acknowledge failure. This bit is set by hardware when no acknowledge is returned. An interrupt is generated if ITE=1. It is cleared by software reading SR2 register or by hardware when the interface is disabled (PE=0).

The SCL line is not held low while AF=1.

0: No acknowledge failure

1: Acknowledge failure

Bit 3 = STOPF Stop detection. This bit is set by hardware when a stop condition is detected on the bus after an acknowledge (if ACK=1). An interrupt is generated if ITE=1. It is cleared by software reading SR2 register or by hardware when the interface is disabled (PE=0). The SCL line is not held low while STOPF=1.

0: No Stop condition detected

1: Stop condition detected

Bit 2 = Reserved. Forced to 0 by hardware.

Bit 1 = BERR Bus error. This bit is set by hardware when the interface detects a misplaced start or stop condition. An interrupt is generated if ITE=1. It is cleared by software reading SR2 register or by hardware when the interface is disabled (PE=0).

The SCL line is not held low while BERR=1.

0: No misplaced Start or Stop condition

1: Misplaced Start or Stop condition

Bit 0 = DDCIF DDC/CI address detected. This bit is set by hardware when the DDC/CI address (6Eh/6Fh) is detected on the bus while DDCIEN=1. It is cleared by hardware when a stop condition (STOPF=1) is detected, or when the interface is disabled (PE=0).

0: No DDC/CI address detected on bus

1: DDC/CI address detected on bus

DDC data register (DDCDR)

Read / Write

Reset Value: 0000 0000 (00h)

7	6	5	4	3	2	1	0
D7	D6	D5	D4	D3	D2	D1	D0

Bits [7:0]= D7-D0 8-bit data register. These bits contain the byte to be received or transmitted on the bus.

Transmitter mode: Byte transmission start automatically when the software writes in the DR register.

Receiver mode: the first data byte is received automatically in the DR register using the least significant bit of the address.
Then, the next data bytes are received one by one after reading the DR register.

DDC own address register 1 (DDCOAR1)

Read / Write

Reset Value: 0000 0000 (00h)

7	6	5	4	3	2	1	0
ADD7	ADD6	ADD5	ADD4	ADD3	ADD2	ADD1	ADD0

Bit [7:1] = ADD7-ADD1 Interface address. These bits define the I²C bus programmable address of the interface. They are not cleared when the interface is disabled (PE=0).

Bit 0 = Reserved. Forced to 0 by hardware.

DDC own address register 2 (DDCOAR2)

Read / Write

Reset Value: 0000 0000 (00h)

7	6	5	4	3	2	1	0
ADD7	ADD6	ADD5	ADD4	ADD3	ADD2	ADD1	ADD0

Bit 7:1 = ADD7-ADD1 Interface address. These bits define the I²C bus programmable address of the interface. They are not cleared when the interface is disabled (PE=0).

Bit 0 = Reserved. Forced to 0 by hardware.

DDC2B control register (DDCDCR)

Read / Write

Reset Value: 0000 0000 (00h)

7	6	5	4	3	2	1	0
0	0	ENDCF	ENDCE	EDF	EDE	WP	DDC2BPE

Bit [7:6] = Reserved. Forced by hardware to 0.

Bit 5 = ENDCF End of Communication interrupt Flag. This bit is set by hardware and cleared by software.

0: NACK or STOP condition not met in read mode.

1: NACK or STOP condition met in read mode.

Bit 4= ENDCE End of communication interrupt enable. This bit is set and cleared by software.

0: End of communication interrupt disabled.

1: End of communication interrupt enabled.

Bit 3= EDF End of download interrupt flag. This bit is set by hardware and cleared by software.

0: Download not started or not completed yet.

1: Download completed. Last byte of data structure (relative address 7Fh or FFh) has been stored or read in RAM.

Bit 2 = EDE End of Download interrupt Enable. This bit is set and cleared by software.

0: End of Download interrupt disabled.

1: End of Download interrupt enabled.

Bit 1 = WP Write Protect. This bit is set and cleared by software.

0: Enable writes to the RAM.

1: Disable DMA write transfers and protect the RAM content.

CPU writes to the RAM are not affected.

Bit 0 = DDC2BPE. DDC2B Peripheral Enable. This bit is set and cleared by software.

0: Release the SDA port pin and ignore SCL port pin. The other bits of the DCR are left unchanged.

1: Enable the DDC Interface and respond to the DDC2B protocol.

Note: When $DDC2BPE = 1$, all the bits of the DCR register are locked and cannot be changed. The desired configuration therefore must be written in the DCR register with $DDC2BPE = 0$ and then set the $DDC2BPE$ bit in a second step.

12 Watchdog timer (WDG)

The watchdog timer is used to detect the occurrence of a software fault, usually generated by external interference or by unforeseen logical conditions, which causes the application program to abandon its normal sequence. The watchdog circuit generates an MCU reset when the programmed time period expires, unless the program refreshes the counter's contents before the T6 bit is cleared. In addition, a second counter prevents the watchdog register from being updated at intervals that are too close.

12.1 Main features

- Programmable timer (64 increments of 50000 CPU cycles)
- Programmable reset
- Reset (if watchdog enabled) when the T6 bit reaches zero
- Reset (if watchdog enabled) on HALT instruction
- Lock-up counter for preventing short time refreshes

Figure 41. Watchdog block diagram

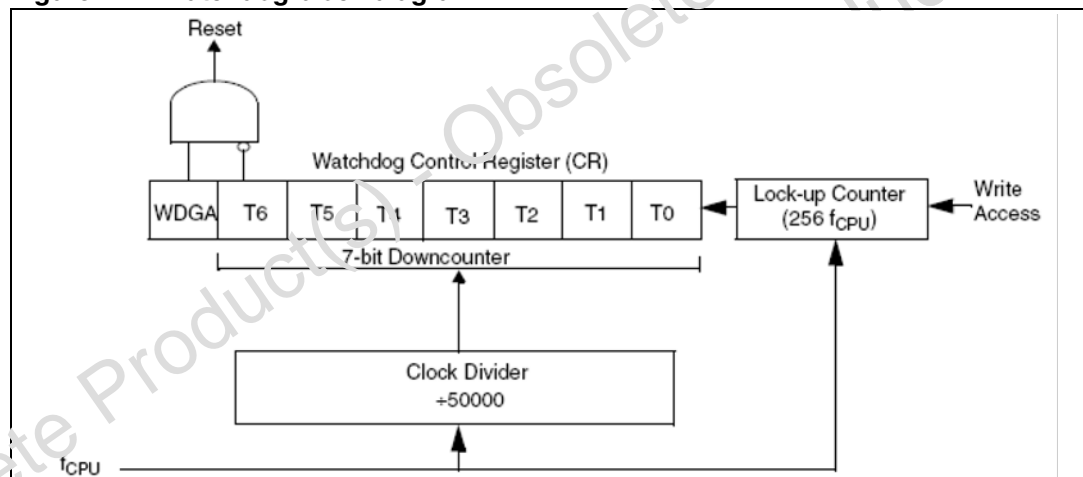

12.2 Main watchdog counter

The counter value stored in the CR register (bits T[6:0]), is decremented every 50000 clock cycles, and the length of the time out period can be programmed by the user in 64 increments.

If the watchdog is enabled (bit WDGA is set) and when the 7-bit timer (bits T[6:0]) rolls over from 40h to 3Fh (T6 is cleared), it initiates a reset cycle pulling low the reset pin for typically 500 ns:

- The WDGA bit is set (watchdog enabled)
- Bit T6 is set to prevent generating an immediate reset
- Bits T[5:0] contain the number of increments which represents the time delay before the watchdog produces a reset.

Following a reset, the watchdog is disabled. Once activated it cannot be disabled, except by a reset.

The T6 bit can be used to generate a software reset (the WDGA bit is set and the T6 bit is cleared).

The application program must write in the CR register at regular intervals during normal operation to prevent an MCU reset. The value to be stored in the CR register must be between FFh and C0h (see [Table 26](#)).

12.3 Lock-up counter

An 8-bit counter starts after a reset or by writing to the CR register. It disables the writing of the CR register during the next 256 cycles of CPU clock (typical value of 32 μs at 8 MHz). If a writing order takes place during this time, this 8-bit counter is reset but not the main watchdog downcounter (no writing to the CR register occurs).

Thus after several too close writings of the CR register, the main downcounter reaches the reset value and a reset occurs. If the CR register is normally refreshed every 32 μs or more, write commands are always enabled.

Table 26. Watchdog timing (f_{CPU} = 8 MHz)

	CR register initial value	WDC timeout (ms)	Lock-up timeout (μs)
Maximum	FFh	400	32
Minimum	C0h	6.250	

12.4 Interrupts

None.

12.5 Register description

Table 27. Watchdog register map

Address	Reset		Register	Bit 7	Bit 6	Bit 5	Bit 4	Bit 3	Bit 2	Bit 1	Bit 0
001Bh	7F	R/W	WDGCR	WDGA	T[6:0]						

7	6	5	4	3	2	1	0
WDGA	T6	T5	T4	T3	T2	T1	T0

Bit 7 = WDGA *Activation bit.*

This bit is set by software and only cleared by hardware after a reset. When WDGA = 1, the watchdog can generate a reset.

0: Watchdog disabled

1: Watchdog enabled

Bits [6:0] = T[6:0] *7-bit timer (MSB to LSB).*

These bits contain the decremented value. A reset is produced when it rolls over from 40h to 3Fh (T6 is cleared).

13 8-bit timer (TIMA)

Timer A is an 8-bit programmable free-running downcounter driven by a programmable prescaler. This block also has a buzzer. The block diagram is shown in [Figure 42](#).

13.1 Main features

- Programmable Prescaler: f_{CPU} divided by 1, 8 or 64
- Overflow status flag and maskable interrupt
- Reduced power mode
- Independent buzzer output with 4 programmable tones

Figure 42. Timer A (TIMA) block diagram

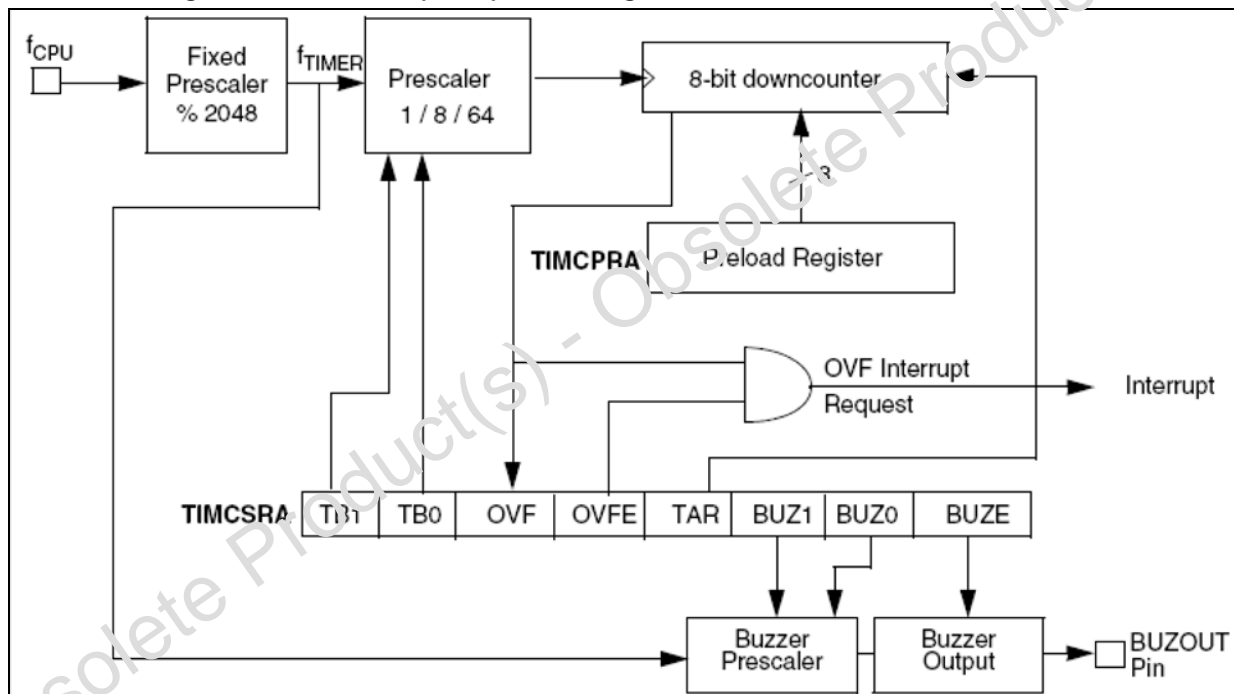

13.2 Functional description

Timer A is a 8-bit downcounter and its associated 8-bit register is loaded as start value of the downcounter each time it has reached the 00h value. A flag indicates that the downcounter rolled over the 00h value. The buzzer has 4 distinct tones. Before the downcounter prescaler block, the frequency is divided by 2048.

$$f_{T\text{IMER}} = f_{\text{CPU}}/2048$$

Note: In One-shot mode, the counter stops at 00h (low power state).

13.3 Register description

Table 28. Timer controller register map

Address	Reset		Register	Bit 7	Bit 6	Bit 5	Bit 4	Bit 3	Bit 2	Bit 1	Bit 0
000Dh	00h	R/W	TIMCSRA	TB1	TB0	OVF	OVFE	TAR	BUZ1	BUZ0	BUZE
000Eh	00h	R/W	TIMCPRA	PR7	PR6	PR5	PR4	PR3	PR2	PR1	PR0

7	6	5	4	3	2	1	0
TB1	TB0	OVF	OVFE	TAR	BUZ1	BUZ0	BUZE

Bits [7:6] = TB[1:0] Time base period selection

These bits are set and cleared by software.

00: Time base period = t_{TIMER} (256 μ s @ 8 MHz)

01: Time base period = $t_{TIMER} \times 8$ (2048 μ s @ 8 MHz)

10: Time base period = $t_{TIMER} \times 64$ (16384 μ s @ 8 MHz)

11: Reserved

Bit 5 = OVF Timer overflow flag.

This bit is set by hardware. An interrupt is generated if $OVFE = 1$. It must be cleared by reading the TIMCSRA register.

0: No timer overflow.

1: The free-running downcounter reached 00h.

Bit 4 = OVFE Timer overflow interrupt enable.

This bit is set and cleared by software.

0: Interrupt disabled

1: Interrupt enabled

Bit 3 = TAR Timer auto-reload

This bit is set and cleared by software.

0: One-shot mode. The counter restarts after a write in the TIMCPRA register.

1: Auto-Reload mode. The counter is reloaded automatically by the TIMCPRA register after the downcounter reaches 00h.

Bits [2:1] = BUZ[1:0] Buzzer tone selection

These bits are set and cleared by software.

00: Time base frequency = $f_{TIMER}/16$ (244 Hz @ 8 MHz)

01: Time base frequency = $f_{TIMER}/8$ (488 Hz @ 8 MHz)

10: Time base frequency = $f_{TIMER}/4$ (976 Hz @ 8 MHz)

11: Time base frequency = $f_{TIMER}/2$ (1.95 kHz @ 8 MHz)

Bit 0 = BUZE *Buzzer enable*

This bit is set and cleared by software.

0: Buzzer disabled

1: Buzzer enabled. It has priority over any other alternate function mapped onto the same pin (PWM).

TIMER A counter preload register (TIMCPRA)

Read/Write

Reset Value: (00h)

7	6	5	4	3	2	1	0
PR7	PR6	PR5	PR4	PR3	PR2	PR1	PR0

Bits [7:0] = PR[7:0] *Counter preload data*

These bits are set and cleared by software.

They are used to hold the reload value which is immediately loaded in the counter.

Note: The N number loaded in TIMCPRA register corresponds to a time of $(N + 1) \times$ Period timer. The "00" value is prohibited.

14 8-bit timer with external trigger (TIMB)

Timer B is an 8 bit-programmable free-running downcounter, driven by a programmable prescaler. An external signal can also trigger the countdown. The Timer B block diagram is shown in [Figure 43](#).

14.1 Main features

- Programmable Prescaler: f_{CPU} divided by 1, 8 or 16
- Overflow status flag and maskable interrupt
- Auto reload capability
- An external signal with programmable polarity can trigger the count-down

Figure 43. External timer block diagram

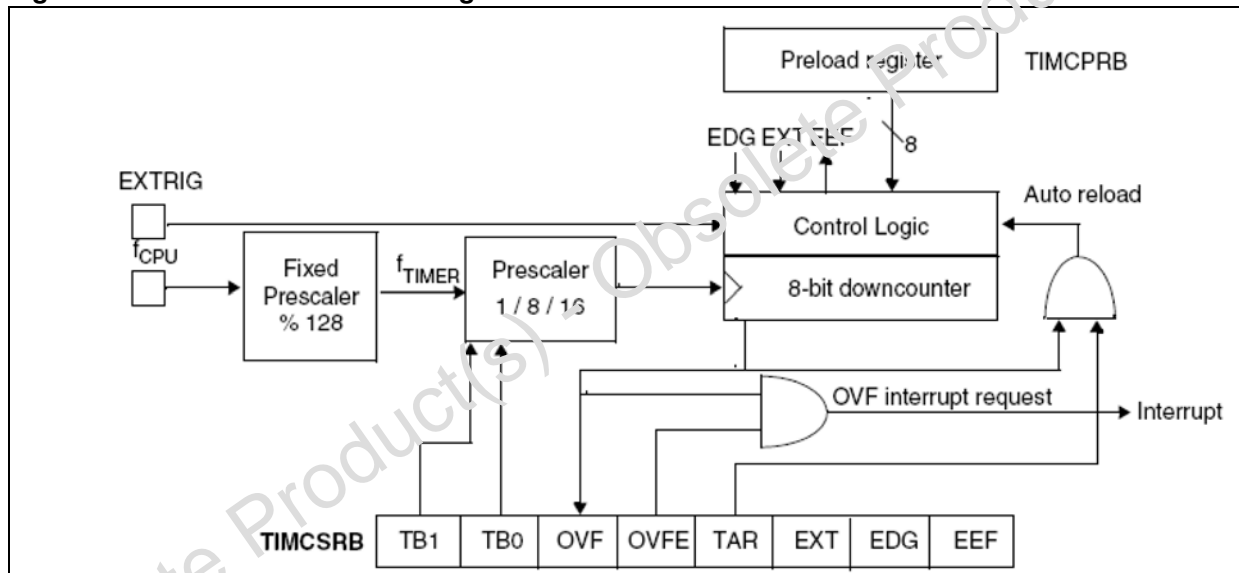

14.2 Functional description

The 8 bit-downcounter timer counts from a start value down to 00h. The start value is preloaded from the associated 8-bit TIMCPRB register every time it is written, or when the counter has reached the 00h value (Auto Reload feature) if the TAR bit is set. The OVF flag is set when the downcounter reaches 00h. An interrupt is generated if the OVFE bit is set.

When the EXT bit is set, an external signal edge triggers the countdown start. The EDG bit controls the rising or falling signal edge. Once detected, the selected edge sets the EE flag, preloads the downcounter with the start value and starts the countdown as usual.

During the countdown, the downcounter cannot be retriggered and subsequent pulses occurring after the countdown has started are ignored until the counter reaches 00h.

There are four possible operating modes as described in [Table 29](#).

Table 29. Timer operating mode

TAR	EXT	Timer mode
0	0	One-shot after the TIMCPRB register write (no auto reload)
0	1	One-shot after the external signal detection (no auto reload). Only the very first external pulse triggers the countdown (Note 2)
1	0	Downcounter auto-reload when 00h reached Downcounter reloaded with TIMCPRB register value, count-down restarts
1	1	One-shot for each external signal detection. Downcounter preloaded with TIMCPRB when 00h reached. Countdown restarts after the next external signal detection.

- Note: 1 The downcounter value cannot be read.
 2 Change the EXT value to exit the external one-shot mode.

Table 30. Timer controller register map

Address	Reset		Register	Bit 7	Bit 6	Bit 5	Bit 4	Bit 3	Bit 2	Bit 1	Bit 0
0038h	00h	R/W	TIMCSR	TB1	TB0	OVF	OVFE	TAR	EXT	EDG	EFF
0039h	00h	R/W	TIMCPRB	PR7	PR6	PR5	PR4	PR3	PR2	PR1	PR0

TIMER B control status register (TIMCSR)

Read/Write

Reset value: (00h)

7								0			
TB1	TB0	OVF	OVFE	TAR	EXT	EDG	EFF				

Bits [7:6] = TB[1:0] Time base period selection

These bits are set and cleared by software.

00: Time base period = t_{TIMER} (16 μ s @ 8 MHz)

01: Time base period = $t_{TIMER} \times 8$ (128 μ s @ 8 MHz)

10: Time base period = $t_{TIMER} \times 16$ (256 μ s @ 8 MHz)

11: Reserved

Bit 5 = OVF Timer overflow flag

This bit is set by hardware. An interrupt is generated if OVFE = 1. It must be cleared by reading the TIMCSR register.

0: No timer overflow

1: The free running downcounter rolled over from 00h

Bit 4 = OVFE Timer overflow interrupt enable

This bit is set and cleared by software.

0: Interrupt disabled



1: Interrupt enabled

Bit 3 = TAR *Timer auto reload*

This bit is set and cleared by software.

0: One-shot mode. The counter restarts after writing to the TIMCPRB register.

1: Auto reload mode. The counter is reloaded automatically from the TIMCPRB register when 00h is reached.

Bit 2 = EXT *External trigger*

This bit is set and cleared by software.

0: Internal. The downcounter restarts after writing to the TIMCPRB register or after an auto-reload if the TAR bit is set

1: External. The downcounter is preloaded with the TIMCPRB register but the countdown starts only when the external signal is detected, not by writing to the TIMCPRB register.

Bit 1 = EDG *External signal edge*

This bit is set and cleared by software.

0: A rising edge signal starts the count-down.

1: A falling edge signal starts the count-down

Bit 0 = EEf *External event flag*

This bit is set and cleared by hardware when an external event occurs.

This bit is cleared when the counter reaches "00h" in External mode or when the value of the EXT bit is changed by software.

In Internal mode, this bit is set when the selected edge is detected (the EDG bit) but it is never cleared by itself. It may then be used as a simple edge detector.

TIMER B counter preload register (TIMCPRB)

Read/Write

Reset value: (01h)

7	6	5	4	3	2	1	0
PR7	PR6	PR5	PR4	PR3	PR2	PR1	PR0

Bits [7:0] = PR[7:0] *Counter preload data*

This bit is set and cleared by software.

Bits hold the reload value which is loaded in the counter either immediately (EXT = 0) or when the external signal is detected (EXT = 1).

Note: The N number loaded in TIMCPRB register corresponds to a time of $(N + 1) \times \text{Period timer}$. The "00" value is prohibited.

15 Infrared preprocessor (IFR)

The infrared preprocessor measures the intervals between two adjacent edges of a serial input.

15.1 Main features

- Interval measurement between 2 edges (Time Base = 12.5 kHz) @ $f_{\text{CPU}} = 8 \text{ MHz}$
- Choice of active edge
- Glitch filter
- Overflow detection (20.4 ms = 255/12.5 kHz)
- Maskable interrupt

15.2 Functional description

The IR Preprocessor measures the interval between two adjacent edges of the IFR input signal.

The POSED and NEGED bits determine if the intervals of interest involve:

- consecutive positive edges
- negative edges
- or any pair of edges as described in [Table 31](#).

Figure 44. IFR block diagram

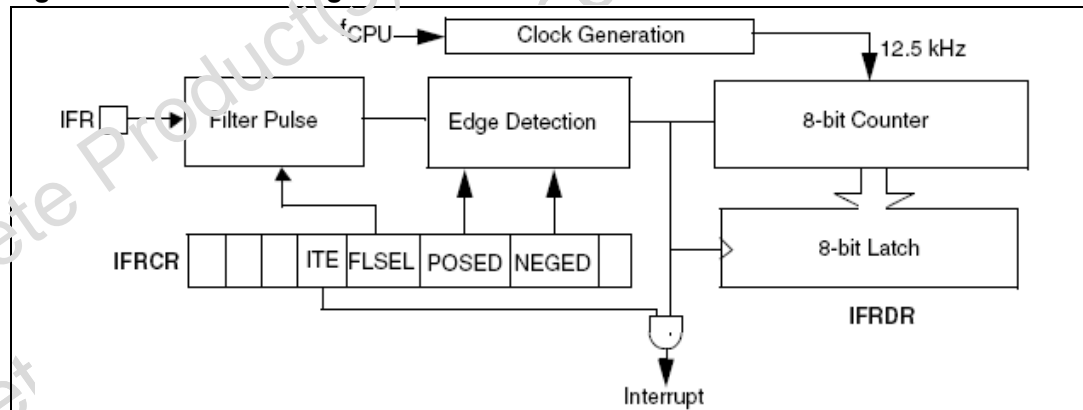

The measurement is a count resulting from a 12.5 kHz clock. Therefore, any pulse width that is less than 80 μs cannot be detected.

Whenever an edge of the specified polarity is detected, the count accumulated since the previously detected edge is latched into the IFRDR register, an interrupt is generated and the counter is reset.

If an edge is not detected within 20.4 ms ($f_{\text{CPU}} = 8 \text{ MHz}$) and the count reaches its maximum value of 255, it is latched immediately. The internal interrupt flag and also an internal overflow flag are set. The latch content remains unchanged as long as the overflow flag is set.

The count stored in the latch register is overwritten in case the microcontroller fails to execute the read before the next edge. Writing to the IFRDR register clears the interrupt and internal overflow flag.

The IFR input signal is preprocessed by a spike filter. This filter removes all pulses with a positive level that lasts less than 2 μs or 160 μs , depending on the FLSEL bit. The negative level can be of any duration and is never filtered out.

Note: If the interrupt is enabled but no signal is detected, an interrupt occurs every 20.4 ms.

15.3 Register description

Infrared data register (IFRDR)

Read/Write

Reset Value: (00h)

7	6	5	4	3	2	1	0
IR7	IR6	IR5	IR4	IR3	IR2	IR1	IR0

Bits [7:0] = IR[7:0] Infra red pulse width

The 8-bit counter value is transferred in this register when an expected edge occurs on the IFR pin or when the counter overflows. A write to this register resets the internal overflow flag.

Infrared control register (IFRCR)

Read/Write

Reset Value: (00h)

7	6	5	4	3	2	1	0
0	0	0	ITE	FLSEL	POSED	NEGED	0

Bits [7:5] = Reserved. Forced by hardware to 0.

Bit 4 = ITE Interrupt enable

0: Interrupt disabled

1: Interrupt enabled. It is generated when an edge (falling and/or rising depending on bits POSED and NEGED) occurs or after a counter overflow.

Bit 3 = FLSEL Spike filter pulse width selection

0: Filter positive pulses narrower than 2 μs

1: Filter positive pulses narrower than 160 μs

Bits [2:1] = POSED, NEGED Edge selection for the duration measurement

Table 31. Duration measurement

POSED	NEGED	Count latch at...
0	0	When count reaches 255
0	1	Negative transition of IFR or when count reaches 255
1	0	Positive transition of IFR or when count reaches 255
1	1	Positive or negative transition of IFR or when count reached 255

Bit 0 = Reserved. Forced by hardware to 0.

Obsolete Product(s) - Obsolete Product(s)
Obsolete Product(s) - Obsolete Product(s)

16 Registers

16.1 Register description

Name register (NAMER)

Read only

Reset value: 00h

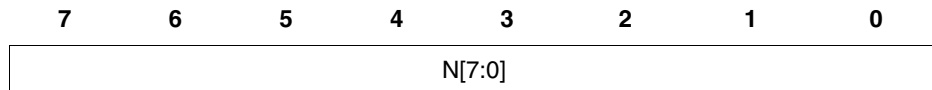

Bits [7:0] = N[7:0] *Circuit Name*

This register indicates the version number of the circuit. The current value is 01h.

Table 32. ST7FLCD1 register summary

Address	Reset		Register	Bit7	Bit6	Bit5	Bit4	Bit3	Bit2	Bit1	Bit0
0000h	00h	R	NAMER								
0001h	00h		MISCR	0	0	0	0	0	PA5OVD	PA4OVD	0
0002h	00h	R/W	PADR	PADR[7:0]							
0003h	00h	R/W	PADDR	PADDR[7:0]							
0004h	00h	R/W	PBDR	PBDR[7:0]							
0005h	00h	R/W	PBDDR	PBDDR[7:0]							
0006h	00h	R/W	PCDR	PCDR[7:0]							
0007h	00h	R/W	PCDDR	PCDDR[7:0]							
0008h	00h	R/W	PDDR	PDDR[7:0]							
0009h	00h	R/W	PDDDR	PDDDR[7:0]							
000Ah	00h	R	ADCDR	AD[7:0]							
000Bh	00h	R/W	ADCCSR	COCO	0	ADON	0	0	0	CH[1:0]	
000Ch	00h	R/W	ITRFRE	0	0	ITB EDGE	ITBLAT	ITBITE	ITA EDGE	ITALAT	ITAITE
000Dh	00h	R/W	TIMCSRA	TB1	TB0	OVF	OVFE	TAR	BUZ1	BUZ0	BUZE
000Eh	00h	R/W	TIMCPRA	PR7	PR6	PR5	PR4	PR3	PR2	PR1	PR0
000Fh	00h	R/W	PWMDCR0	DCR0[7:0]							
0010h	00h	R/W	PWMDCR1	DCR1[7:0]							
0011h	00h	R/W	PWMDCR2	DCR2[7:0]							
0012h	00h	R/W	PWMDCR3	DCR3[7:0]							
0013h	00h	R/W	PWMCRA	OE3	OE2	OE1	OE0	OP3	OP2	OP1	OP0
0014h	FFh	R/W	PWMARRA	ARRA[7:0]							
0015h	00h	R/W	PWMDCR4	DCR4[7:0]							



Table 32. ST7FLCD1 register summary (continued)

Address	Reset		Register	Bit7	Bit6	Bit5	Bit4	Bit3	Bit2	Bit1	Bit0
0016h	00h	R/W	PWMDCR5	DCR5[7:0]							
0017h	00h	R/W	PWMCRB	0	0	OE5	OE4	0	0	OP5	OP4
0018h	FFh	R/W	PWMARRB	ARRB[7:0]							
0019h	00h	R/W	FCSR								
001Ah			Reserved								
001Bh	7F	R/W	WDGCR	WDGA	T[6:0]						
001Ch	00h	R/W	I2CCR	00		PE	0	START	ACK	STOP	ITE
001Dh	00h	R	I2CSR	EVF	AF	TRA	0	BTF	0	M/IDL	SEL
001Eh	00h	R/W	I2CCCR	FM/SM	Filter of f	CC5 ...CC0					
001Fh	00h	R/W	I2CDR	DR[7:0]							
0020h	00h	R/W	DDCCRA	0	0	PE	DDCCIE N	0	ACK	STOP	ITE
0021h	00h	R	DDCSR1A	EVF	0	TRA	BUSY	BTF	ADSL	0	0
0022h	00h	R	DDCSR2A	0	0	0	AF	STOPF	0	BERR	DDCCIF
0023h	00h	R/W	DDCOAR1A	ADD[7:0]							
0024h	00h	R/W	DDCOAR2A	ADD[7:0]							
0025h	00h	R/W	DDCDRA	DR[7:0]							
0026h			Reserved								
0027h	00h	R/W	DDCCRA	0	0	ENDCF	ENDCE	EDF	EDE	WP	HWPE
0028h	00h	R/W	DDCCRB	0	0	PE	DDCCIE N	0	ACK	STOP	ITE
0029h	00h	R	DDCSR1B	EVF	0	TRA	BUSY	BTF	ADSL	0	0
002Ah	00h	R	DDCSR2B	0	0	0	AF	STOPF	0	BERR	DDCCIF
002Bh	00h	R/W	DDCOAR1B	ADD[7:0]							
002Ch	00h	R/W	DDCOAR2B	ADD[7:0]							
002Dh	00h	R/W	DDCDB	DR[7:0]							
002Eh			Reserved								
002Fh	00h	R/W	DDCCRB	0	0	ENDCF	ENDCE	EDF	EDE	WP	HWPE
0030h	00h	R/W	DMCR	WDGOFF	MTR	BC2	BC1	BC0	BIR	BIW	AIE
0031h	10h	R	DMSR	WP	STE	STF	RST	BRW	BK2F	BK1F	AF
0032h	FFh	R/W	DMBK1H	BK1H7	BK1H6	BK1H5	BK1H4	BK1H3	BK1H2	BK1H1	BK1H0
0033h	FFh	R/W	DMBK1L	BK1L7	BK1L6	BK1L5	BK1L4	BK1L3	BK1L2	BK1L1	BK1L0

Table 32. ST7FLCD1 register summary (continued)

Address	Reset		Register	Bit7	Bit6	Bit5	Bit4	Bit3	Bit2	Bit1	Bit0
0034h	FFh	R/W	DMBK2H	BK2H7	BK2H6	BK2H5	BK2H4	BK2H3	BK2H2	BK2H1	BK2H0
0035h	FFh	R/W	DMBK2L	BK2L7	BK2L6	BK2L5	BK2L4	BK2L3	BK2L2	BK2L1	BK2L0
0036h	00h	R	IFRDR	IR7	IR6	IR5	IR4	IR3	IR2	IR1	IR0
0037h	00h	R/W	IFRCR	0	0	0	ITE	FLSEL	POSE D	NEGE D	-
0038h	00h	R/W	TIMCSRB	TB1	TB0	OVF	OVFE	TAR	EXT	EDG	EEF
0039h	01h	R/W	TIMCPRB	PR7	PR6	PR5	PR4	PR3	PR2	PR1	PR0
003Ah			Reserved								

17 Electrical characteristics

The ST7FLCD1 device contains circuitry to protect the inputs against damage due to high static voltage or electric field. Nevertheless it is advised to take normal precautions and to avoid applying to this high impedance voltage circuit any voltage higher than the maximum rated voltages. It is recommended for proper operation that V_{IN} and V_{OUT} be constrained to the range:

$$V_{SS} \leq (V_{IN} \text{ or } V_{OUT}) \leq V_{DD}$$

To enhance reliability of operation, it is recommended to connect unused inputs to an appropriate logic voltage level such as V_{SS} or V_{DD} . All the voltages in the following table, are referenced to V_{SS} .

17.1 Absolute maximum ratings

Table 33. Absolute maximum ratings

Symbol	Ratings	Value	Unit
V_{DD}	Recommended Supply Voltage	-0.3 to +6.0	V
V_{IN}	Input Voltage	$V_{SS} - 0.3$ to $V_{DD} + 0.3$	V
V_{AIN}	Analog Input Voltage (A/D Converter)	$V_{SS} - 0.3$ to $V_{DD} + 0.3$	V
V_{OUT}	Output Voltage	$V_{SS} - 0.3$ to $V_{DD} + 0.3$	V
I_{IN}	Input Current	-10 to +10	mA
I_{OUT}	Output Current	-10 to +10	mA
I_{INJ}	Accumulated injected current of all I/O pins (V_{DD} , V_{SS})	40	mA
T_A	Operating Temperature Range	0 to +70	°C
T_{STG}	Storage Temperature Range	-65 to +150	°C
T_J	Junction Temperature	150	°C
PD	Power Dissipation	TBD	mW
ESD	ESD susceptibility	2000	V

17.2 Power considerations

The average chip-junction temperature, T_J , in degrees Celsius, may be calculated using the following equation:

$$T_J = T_A + (P_D \times \theta_{JA}) \quad (1)$$

Where:

- T_A is the ambient temperature in ° C,
- θ_{JA} is the package junction-to-ambient thermal resistance, in ° C/W
- P_D is the sum of P_{INT} and $P_{I/O}$. P_{INT} is the product of I_{DD} and V_{DD} , expressed in Watts. This is the chip internal power
- $P_{I/O}$ represents the power dissipation on input and output pins; user determined.

For most applications $P_{I/O} < P_{INT}$ and may be neglected. $P_{I/O}$ may be significant if the device is configured to drive Darlington bases or sink LED Loads. An approximate relationship between P_D and T_J (if $P_{I/O}$ is neglected) is given by:

$$P_D = K + (T_J + 273^\circ\text{C}) \quad (2)$$

Therefore:

$$K = P_D \times (T_A + 273^\circ\text{C}) - \theta_{JA} \times P_D^2 \quad (3)$$

Where:

K is constant for the particular port, which may be determined from equation (3) by measuring P_D (at equilibrium) for a known T_A . Using this value of K, the values of P_D and T_J may be obtained by solving equations (1) and (2) iteratively for any value of T_A .

17.3 Thermal characteristics

Table 24 Thermal characteristics

Symbol	Package	Value	Unit
θ_{JA}	28-pin small outline package (SO28)	69	°C/W

17.4 AC/DC electrical characteristics

All voltages are referred to V_{SS} and $T_A = 0$ to $+70^\circ\text{C}$ (unless otherwise specified)

Table 35. AC/DC electrical characteristics

Symbol	Parameter	Conditions	Min.	Typ.	Max.	Unit
General						
V_{DD}	Operating supply voltage		4.5	5	5.5	V
	Operating voltage for FLASH access	READ	3.8			V
		WRITE/ERASE	4.5		5.5	V
I_{DD}	CPU RUN mode	I/O in input mode $V_{DD} = 5\text{V}$ $f_{CPU} = 8\text{MHz}$, $T_A = 20^\circ\text{C}$		14	18	mA
	CPU WAIT mode			12	10	mA
	CPU HALT mode			1	10	μA
Control timing						
f_{OSC}	External frequency			24	27	MHz
f_{CPU}	Internal frequency			8	9	MHz
t_{BU}	Startup time built-up time	Crystal resonator		8	20	ms
t_{RL}	External RESET input pulse width		1000			ns
t_{PORL}	Internal power reset duration		4096			t_{CPU}
t_{POWL}	Watchdog RESET output pulse width		500			ns
t_{DOG}	Watchdog time-out	$f_{CPU} = 8\text{MHz}$	50000 6.25		320000 0 400	t_{CPU} ms
t_{ILIL}	Interrupt pulse period		See Note 1			t_{CPU}
t_{OXOV}	Crystal oscillator start-up time				50	ms
t_{DDR}	Power-up rise time	V_{DD} min.	1		100	ms
Standard I/O port pins						
V_{OL}	Output low level voltage port A[7:6,3:0], Port B[3:0], push pull	$I_{OL} = 2\text{mA}$ and $V_{DD} = 5\text{V}$			0.4	V
V_{OL}	Output low level voltage port C[1:0] Open Drain	$I_{OL} = 4\text{mA}$ and $V_{DD} = 5\text{V}$			0.4	V
V_{OL}	Output low level voltage port A[5:4] (See Note 2)	$I_{OL} = 8\text{mA}$ and $V_{DD} = 5\text{V}$ $I_{OL} = 2\text{mA}$ and $V_{DD} = 5\text{V}$			0.4	V
V_{OL}	Output low level voltage port D[7:0] Open Drain	$I_{OL} = 4\text{mA}$ and $V_{DD} = 5\text{V}$			0.4	V
V_{OH}	Output high level voltage port A[7:6,3:0], Port B[3:0], Push Pull	$I_{OH} = 2\text{mA}$	$V_{DD}-0.8$			V
V_{OH}	Output high level voltage port A[5:4]	$I_{OH} = 2\text{mA}$ $I_{OH} = 8\text{mA}$	$V_{DD}-0.8$			V

Table 35. AC/DC electrical characteristics (continued)

V_{OH}	Output high level voltage Port C[1:0], Port D (See Note 3)				V_{DD}	V
V_{IH}	Input High Level Voltage Port A [7:0], Port B [3:0], Port C [1:0], Port D[7:0], \overline{RESET}	Leading edge		$0.7 * V_{DD}$	V_{DD}	V
V_{IL}	Input low level voltage Port A [7:0], Port B [3:0], Port C [1:0], Port D[7:0], \overline{RESET}	Trailing edge		V_{SS}	$0.2 * V_{DD}$	V
I_{IL}	I/O Ports Hi-Z Leakage Current Port A[7:0], Port B[3:0], Port C[1:0], Port D[7:0], \overline{RESET}				10	μA
C_{OUT} C_{IN}	Capacitance: Ports (as input or output), \overline{RESET}				128	pF
IRPU	Pull-up resistor current	$V_{DD} = 5V$ $V_{IN} = V_{SS}$ $T = 25^{\circ}C$	30	60	100	μA

- Note:
- 1 The minimum period t_{ILIL} should not be less than the number of cycles times it takes to execute the interrupt service routine plus 21 cycles.
 - 2 For the case of $I_{OL} = 8$ mA, 8 mA output current if corresponding overdrive bit = 1 in MISCR register.
 - 3 Output high level by means of external pull-up resistor.

17.5 Power on/off electrical specifications

Table 36. Power on/off electrical specifications

Symbol	Parameter	Conditions	Min.	Typical	Max.	Unit
V_{TRH}	Power ON/OFF Reset Trigger V_{DD} rising edge	V_{DD} Variation 50mV/mS	3.8	4	4.2	V
V_{TRL}	Power ON/OFF Reset Trigger V_{DD} rising edge	V_{DD} Variation 50mV/mS	3.75	4	4.2	V
V_{THM}	V_{DD} minimum for Power ON/OFF Reset active	V_{DD} Variation 50mV/mS		TBD		V

17.6 8-bit analog-to-digital converter

Table 37. 8-bit analog-to-digital converter

Symbol	Parameter	Conditions	Min.	Typical	Max.	Unit
f _{ADC}	Analog control frequency	V _{DD} = 5 V			2	MHz
I _{TUEI}	Total unadjusted error	f _{CPU} = 8 MHz, f _{ADC} = 2MHz V _{DD} = 5 V	0	1	2	LSB
OE	Offset error		-2	1	2	
GE	Gain error		-2	1	2	
IDLEI	Differential linearity error		0	0.5	1	
IILEI	Integral linearity error		0	1	2	
V _{AIN}	Conversion range voltage		V _{SS}		V _{DD}	V
I _{ADC}	A/D conversion supply current			1		µA
t _{STAB}	Stabilization time after enable ADC	f _{CPU} = 8 MHz,			1	µs
t _{LOAD}	Sample capacitor loading time	f _{ADC} = 2MHz, V _{DD} = 5 V		1 4		µs 1/f _{ADC}
t _{CONV}	Conversion time			2 8		µs 1/f _{ADC}
R _{AIN}	External input resistor				15	kΩ
R _{ADC}	Internal input resistor			1.5		kΩ
C _{SAMPLE}	Sample capacitor			6		pF

17.7 I2C/DDC bus electrical specifications

Table 38. I2C/DDC bus electrical specifications

Symbol	Parameter	Standard mode		Fast mode		Unit
		Min.	Max.	Min.	Max.	
V _{HYS}	Hysteresis of Schmitt trigger inputs					V
	Fixed input levels	na	na	0.2		
	VDD-related input levels	na	na	0.05 V _{DD}		
T _{SP}	Pulse width of spikes which must be suppressed by the input filter	na	na	0 ns	50 ns	ns
T _{OF}	Output fall time from VIH min to VIL max with a bus capacitance from 10 pF to 400 pF					ns
	with up to 3 mA sink current at VOL1		250	20+0.1 C _b	250	
	with up to 6 mA sink current at VOL2	na	na	20+0.1 C _b	250	



Table 38. I²C/DDC bus electrical specifications

Symbol	Parameter	Standard mode		Fast mode		Unit
		Min.	Max.	Min.	Max.	
I	Input current each I/O pin with an input voltage between 0.4V and 0.9 V _{DD} max	-10	10	-10	10	μA
C	Capacitance for each I/O pin		10		10	pF

Note: *na* = not applicable
Cb = capacitance of one bus in pF

17.8 I²C/DDC bus timings

Table 39. I²C/DDC bus electrical specifications

Symbol	Parameter	Standard mode		Fast mode		Unit
		Min.	Max.	Min.	Max.	
T _{BUF}	Bus free time between STOP and START condition	4.7		1.3		ms
t _{HD:STA}	Hold time START condition. After this period, the first clock pulse is generated	4.0		0.6		μs
t _{LOW}	Low period of the SCL clock	4.7	na	1.3		μs
t _{HIGH}	High period of the SCL clock	4.0		0.6		μs
t _{SU:STA}	Set-up time for a repeated START condition	4.7		0.6		ns
t _{HD:DAT}	Data hold time	0 ⁽¹⁾		0	0.9 ⁽²⁾	ns
t _{SD:DAT}	Data set-up time	250		100		ns
t _R	Rise time for both SDA and SCL signals		1000	20+0.1 Cb	300	ns
t _F	Fall time for both SDA and SCL signals		300	20+0.1 Cb	300	ns
t _{SU:STO}	Input current each I/O pin with an input voltage between 0.4V and 0.9 V _{DD} max	4.0		0.6		μA
C	Capacitance load for each bus line		400		400	pF

1. The device must internally provide a hold time of at least 300 ns for the SDA signal in order to bridge the undefined region of the falling edge of SCL
2. The maximum hold time of the start condition has only to be met if the interface does not stretch the low period of SCL signal

Cb = total capacitance of the bus line in pF

I²C parameters compliant with I²C bus specifications up to 400 kHz only. Faster speeds are at user responsibility.

Figure 45. I2C bus timing

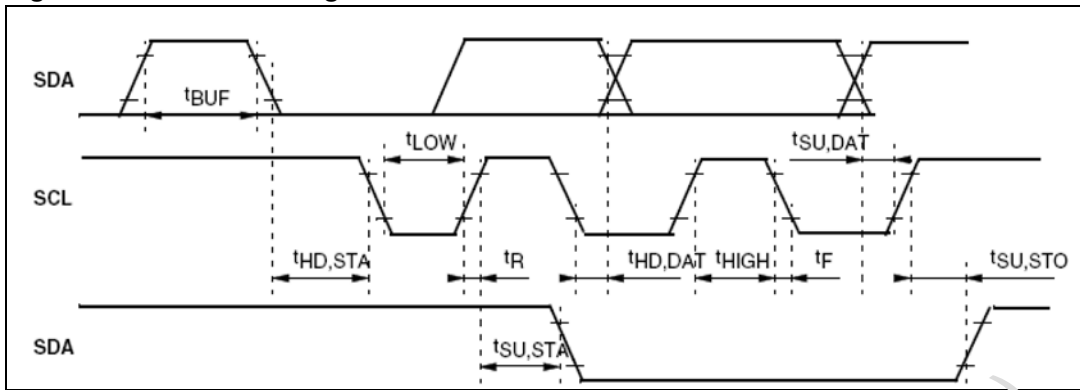

Obsolete Product(s) - Obsolete Product(s)
Obsolete Product(s) - Obsolete Product(s)

18 Package mechanical data

Figure 46. 28-pin small outline package (SO28)

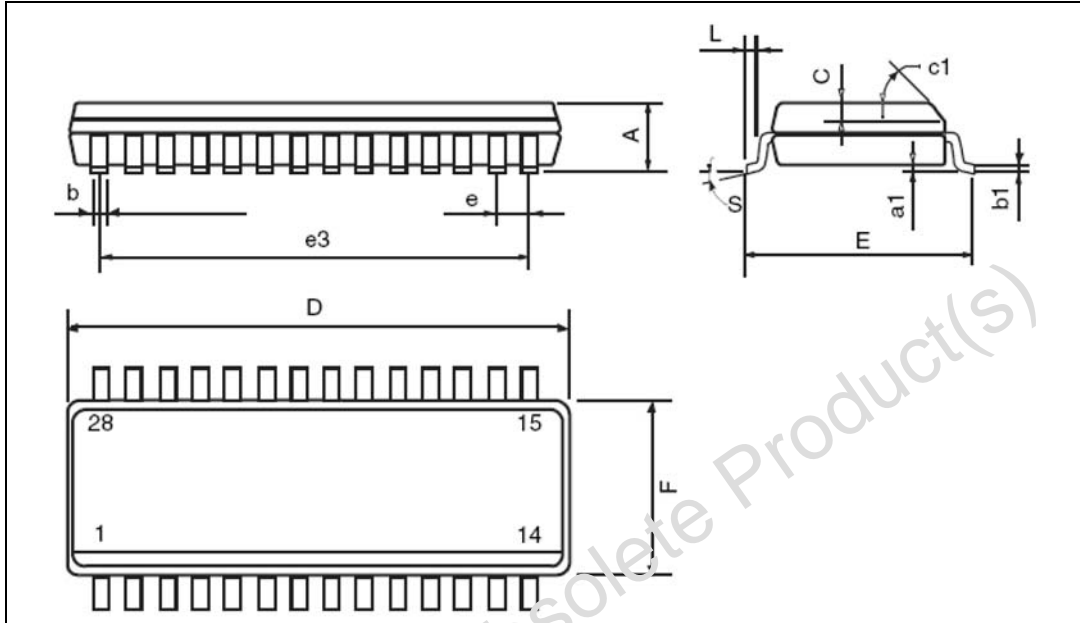

Table 40. JEDEC standard package dimensions

Dimensions	Mm			Inch		
	Min.	Typ.	Max.	Min.	Typ.	Max.
A			2.65			0.104
a1	0.1		0.3	0.004		0.012
b	0.35		0.49	0.014		0.019
b1	0.23		0.32	0.009		0.013
c		0.5			0.020	
c1	45° (typ.)					
D	17.7		18.1	0.697		0.713
E	10		10.65	0.394		0.419
e		1.27			0.050	
e3		16.51			0.65	
F	7.4		7.6	0.291		0.299
L	0.4		1.27	0.016		0.050
S	8° (max.)					

18.1 Lead-free packaging

To meet environmental requirements, ST offers these devices in ECOPACK® packages. These packages have a lead-free second level interconnect. The category of second level interconnect is marked on the package and on the inner box label, in compliance with JEDEC Standard JESD97. The maximum ratings related to soldering conditions are also marked on the inner box label.

ECOPACK is an ST trademark. ECOPACK specifications are available at: www.st.com.

Obsolete Product(s) - Obsolete Product(s)
Obsolete Product(s) - Obsolete Product(s)

19 Revision history

Table 41. Document revision history

Date	Revision	Changes
May-2002	2.1	Addition of Section 5.5 and Section 5.6
19-Aug-2002	2.2	Update of Chapter numbering system. Update of Figure 2: 28-pin Small Outline Package (SO28) Pinout , Figure 12: Typical ICP Interface , Pin 14 becomes PA6/ITA/EXTRIG. Addition of MISCRCR register (0001h) and update of DDC2B Control Register data. Lock-up Counter info added in Section 12: Watchdog Timer (WDG) . Buzzer output info added in Section 13: 8-bit Timer (TIMA) . Modification of oscillator frequency from 24 MHz to maximum of 27 MHz, Fast I ² C mode up to 800 kHz (for certain applications), Section 8: PWM Generator , Section 10.5: Transfer Sequencing and Section 11.6: Transfer Sequencing . Addition of Section 17: Electrical Characteristics and Section 19: Revision History .
24-Sep-2002	2.3	Modification of Figure 4: Program Memory Map .
14-Oct-2002	2.4	Modification of Figure 4: Program Memory Map and Table 34: Summary of Modifications .
4-Dec-2002	2.5	Modification of I ² C Clock Control register.
6-Feb-2003	2.6	Change of VTRH and VTRL values in Section 17.4: AC/DC Electrical Characteristics .
11-Feb-2002	2.7	Addition of Section 1.5: External Connections . Update of DDC2B Control Register (Bit 3) information in Section 11.7: Register Description . Change of VDD values in Section 17.4: AC/DC Electrical Characteristics .
2-Sep-2003	2.8	Modification of values in Section 17.4: AC/DC Electrical Characteristics , Section 17.5: PowerOn/Off Electrical Specifications and Section 17.6: 8-bit Analog-to-Digital Converter .
13-Apr-2004	2.9	Addition of VOH row in Standard I/O Port Pins on page 89 . Addition of Note 1 on page 9 .
9-Feb-2005	2.10	Update of Section 6.1.2: Crystal Oscillator Mode on page 32 .
4-Nov-2008	4.0	New template applied, revision number corrected. No change to technical content

Please Read Carefully:

Information in this document is provided solely in connection with ST products. STMicroelectronics NV and its subsidiaries ("ST") reserve the right to make changes, corrections, modifications or improvements, to this document, and the products and services described herein at any time, without notice.

All ST products are sold pursuant to ST's terms and conditions of sale.

Purchasers are solely responsible for the choice, selection and use of the ST products and services described herein, and ST assumes no liability whatsoever relating to the choice, selection or use of the ST products and services described herein.

No license, express or implied, by estoppel or otherwise, to any intellectual property rights is granted under this document. If any part of this document refers to any third party products or services it shall not be deemed a license grant by ST for the use of such third party products or services, or any intellectual property contained therein or considered as a warranty covering the use in any manner whatsoever of such third party products or services or any intellectual property contained therein.

UNLESS OTHERWISE SET FORTH IN ST'S TERMS AND CONDITIONS OF SALE ST DISCLAIMS ANY EXPRESS OR IMPLIED WARRANTY WITH RESPECT TO THE USE AND/OR SALE OF ST PRODUCTS INCLUDING WITHOUT LIMITATION IMPLIED WARRANTIES OF MERCHANTABILITY, FITNESS FOR A PARTICULAR PURPOSE (AND THEIR EQUIVALENTS UNDER THE LAWS OF ANY JURISDICTION), OR INFRINGEMENT OF ANY PATENT, COPYRIGHT OR OTHER INTELLECTUAL PROPERTY RIGHT.

UNLESS EXPRESSLY APPROVED IN WRITING BY AN AUTHORIZED ST REPRESENTATIVE, ST PRODUCTS ARE NOT RECOMMENDED, AUTHORIZED OR WARRANTED FOR USE IN MILITARY, AIR CRAFT, SPACE, LIFE SAVING, OR LIFE SUSTAINING APPLICATIONS, NOR IN PRODUCTS OR SYSTEMS WHERE FAILURE OR MALFUNCTION MAY RESULT IN PERSONAL INJURY, DEATH, OR SEVERE PROPERTY OR ENVIRONMENTAL DAMAGE. ST PRODUCTS WHICH ARE NOT SPECIFIED AS "AUTOMOTIVE GRADE" MAY ONLY BE USED IN AUTOMOTIVE APPLICATIONS AT USER'S OWN RISK.

Resale of ST products with provisions different from the statements and/or technical features set forth in this document shall immediately void any warranty granted by ST for the ST product or service described herein and shall not create or extend in any manner whatsoever, any liability of ST.

ST and the ST logo are trademarks or registered trademarks of ST in various countries.

Information in this document supersedes and replaces all information previously supplied.

The ST logo is a registered trademark of STMicroelectronics. All other names are the property of their respective owners.

© 2008 STMicroelectronics - All rights reserved

STMicroelectronics group of companies

Australia - Belgium - Brazil - Canada - China - Czech Republic - Finland - France - Germany - Hong Kong - India - Israel - Italy - Japan - Malaysia - Malta - Morocco - Singapore - Spain - Sweden - Switzerland - United Kingdom - United States of America

www.st.com