

2 A, high efficiency single inductor buck-boost DC-DC converter and high brightness white LED driver based on the STBB3JCC

Data brief



Description

The STEVAL-ISA141V2 is a product evaluation board based on the STBB3JCC fixed frequency, high efficiency, buck-boost DC-DC converter. The STBB3JCC is capable of driving a HB WLED from a 1.8 V to 5.5 V input voltage supplied by a one cell Li-Ion battery. Thanks to its high switching frequency (2 MHz) it is possible to reduce the size and cost of the external power components. Low FB voltage (100 mV) reduces power dissipation across the external sensing resistor and maximizes the LED current.

Features

- 100 mV voltage feedback
- Input voltage range from 1.8 V to 5.5 V
- 2 A output current at 3.3 V in buck mode ($V_{IN} = 3.6 V$ to 5.5 V)
- 800 mA output current at 3.3 V in boost mode ($V_{IN} 2.0 V$)
- Typical efficiency greater than 94%
- $\pm 2\%$ DC feedback voltage tolerance
- Automatic transition between step-down and boost mode
- Adjustable output voltage from 1.2 V to 5.5 V
- Power save mode (PS) at light load
- 2.0 MHz fixed switching frequency
- Adjustable switching frequency up to 2.4 MHz (by external synchronous square signal)
- Device quiescent current less than 50 A
- Load disconnect during shutdown
- Shutdown function and soft-start
- Shutdown current $< 1 A$
- Available in Flip Chip 20, pitch = 0.4 mm
- RoHS compliant

1 Schematic diagram

Figure 1: STEVAL-ISA141V2 circuit schematic

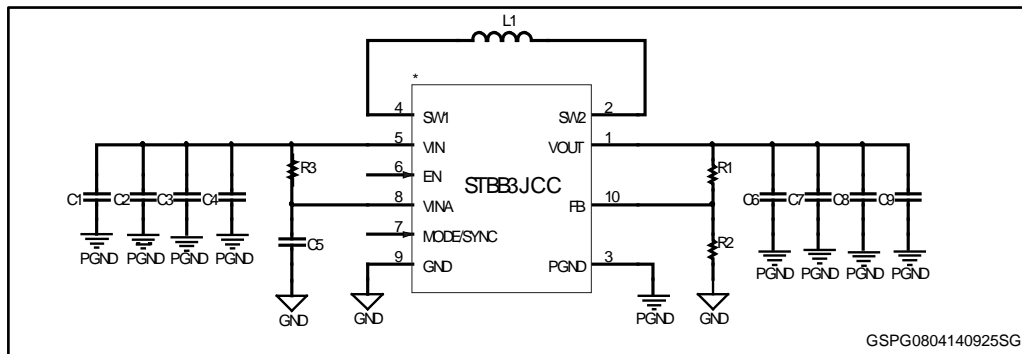

2 Revision history

Table 1: Document revision history

Data	Revision	Changes
27-May-2014	1	Initial release

Please Read Carefully

Information in this document is provided solely in connection with ST products. STMicroelectronics NV and its subsidiaries ("ST") reserve the right to make changes, corrections, modifications or improvements, to this document, and the products and services described herein at any time, without notice.

All ST products are sold pursuant to ST's terms and conditions of sale.

Purchasers are solely responsible for the choice, selection and use of the ST products and services described herein, and ST assumes no liability whatsoever relating to the choice, selection or use of the ST products and services described herein.

No license, express or implied, by estoppel or otherwise, to any intellectual property rights is granted under this document. If any part of this document refers to any third party products or services it shall not be deemed a license grant by ST for the use of such third party products or services, or any intellectual property contained therein or considered as a warranty covering the use in any manner whatsoever of such third party products or services or any intellectual property contained therein.

UNLESS OTHERWISE SET FORTH IN ST'S TERMS AND CONDITIONS OF SALE ST DISCLAIMS ANY EXPRESS OR IMPLIED WARRANTY WITH RESPECT TO THE USE AND/OR SALE OF ST PRODUCTS INCLUDING WITHOUT LIMITATION IMPLIED WARRANTIES OF MERCHANTABILITY, FITNESS FOR A PARTICULAR PURPOSE (AND THEIR EQUIVALENTS UNDER THE LAWS OF ANY JURISDICTION), OR INFRINGEMENT OF ANY PATENT, COPYRIGHT OR OTHER INTELLECTUAL PROPERTY RIGHT.

ST PRODUCTS ARE NOT DESIGNED OR AUTHORIZED FOR USE IN: (A) SAFETY CRITICAL APPLICATIONS SUCH AS LIFE SUPPORTING, ACTIVE IMPLANTED DEVICES OR SYSTEMS WITH PRODUCT FUNCTIONAL SAFETY REQUIREMENTS; (B) AERONAUTIC APPLICATIONS; (C) AUTOMOTIVE APPLICATIONS OR ENVIRONMENTS, AND/OR (D) AEROSPACE APPLICATIONS OR ENVIRONMENTS. WHERE ST PRODUCTS ARE NOT DESIGNED FOR SUCH USE, THE PURCHASER SHALL USE PRODUCTS AT PURCHASER'S SOLE RISK, EVEN IF ST HAS BEEN INFORMED IN WRITING OF SUCH USAGE, UNLESS A PRODUCT IS EXPRESSLY DESIGNATED BY ST AS BEING INTENDED FOR "AUTOMOTIVE, AUTOMOTIVE SAFETY OR MEDICAL" INDUSTRY DOMAINS ACCORDING TO ST PRODUCT DESIGN SPECIFICATIONS. PRODUCTS FORMALLY ESCC, QML OR JAN QUALIFIED ARE DEEMED SUITABLE FOR USE IN AEROSPACE BY THE CORRESPONDING GOVERNMENTAL AGENCY.

Resale of ST products with provisions different from the statements and/or technical features set forth in this document shall immediately void any warranty granted by ST for the ST product or service described herein and shall not create or extend in any manner whatsoever, any liability of ST.

ST and the ST logo are trademarks or registered trademarks of ST in various countries.

Information in this document supersedes and replaces all information previously supplied.

The ST logo is a registered trademark of STMicroelectronics. All other names are the property of their respective owners.

© 2014 STMicroelectronics - All rights reserved

STMicroelectronics group of companies

Australia - Belgium - Brazil - Canada - China - Czech Republic - Finland - France - Germany - Hong Kong - India - Israel - Italy - Japan - Malaysia - Malta - Morocco - Philippines - Singapore - Spain - Sweden - Switzerland - United Kingdom - United States of America

www.st.com