

Energy harvesting demonstration kit based on SPV1050

Data brief

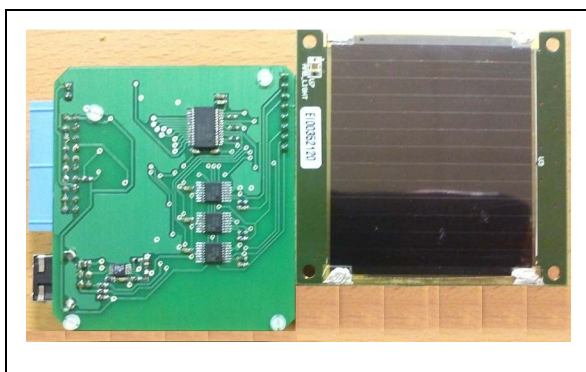

Features

- SPV1050 based harvesting dongle board
- PV module soldered on the back
- Lithium coin cell battery
- PV module electrical characteristics at 200 lux:
 - $V_{OC_TYP} = 9.8\text{ V}$, $I_{SC_TYP} = 20\text{ }\mu\text{A}$
 - $V_{MP_TYP} = 8\text{ V}$, $I_{MP_TYP} = 18\text{ }\mu\text{A}$
- Li-Ion battery:
 - $Capacity_{NOM} = 120\text{ mAh}$
 - $V_{NOMINAL} = 3.6\text{ V}$
 - $V_{CHARGE} = 4.2\text{ V}$
 - $V_{END-OF-DISCHARGE} = 2.75\text{ V}$
- Interface to power monitoring board
- PV module voltage and battery monitoring
- Ambient light sensor for irradiance level measurement
- Supported by SW GUI to show MPPT accuracy and conversion efficiency

Description

The STEVAL-ISV021V1 is a demonstration kit which consists of a complete energy harvesting module based on the SPV1050 ULP energy harvester and battery charger, having the purpose to show the electrical performance of the power converter and many other fundamental electrical quantities related to the overall system.

The power manager is configured as a buck-boost converter, fitting the electrical characteristics of the mounted PV panel and battery.

A power monitoring board along with a software GUI are used to monitor and to graph both of PV panel and battery voltage and current, and system performances like MPPT accuracy and conversion efficiency.

The STEVAL-ISV021V1 represents the standalone harvesting module that can be interfaced with a wireless sensor node to provide the microcontroller, transmitter and sensors with the energy scavenged and stored into the battery.

Furthermore, the STEVAL-ISV021V1 embeds an extension connector to interface and to monitor of some of SPV1050 input and output signals through a microcontroller based board.

1 Schematic and bill of material

The schematic, bill of material and gerber files can be downloaded from the web link:
<http://ims.st.com/referencedesign/photovoltaic.php>.

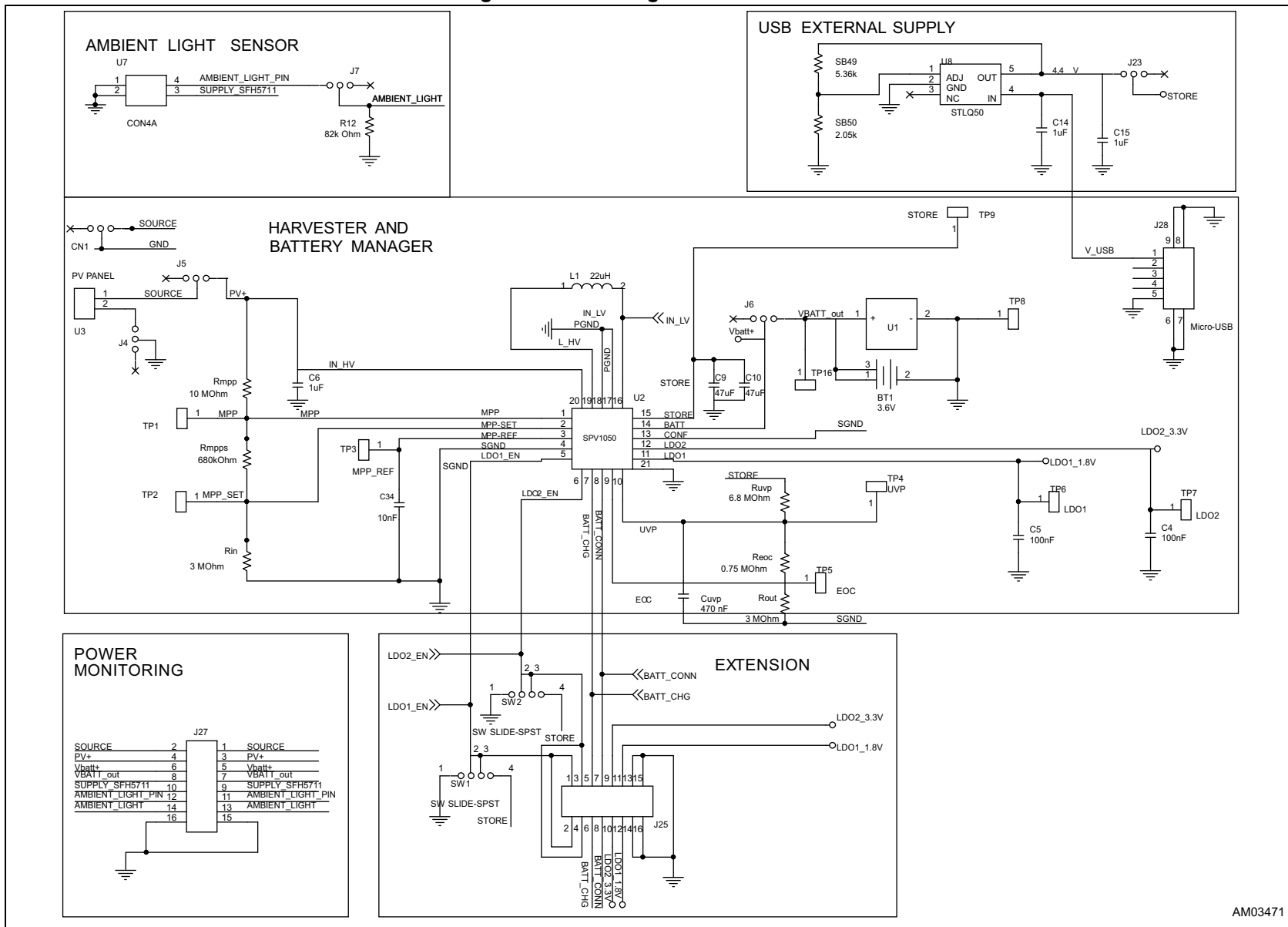
Figure 1. Harvesting module schematic

AM03471



Table 1. Harvesting module BOM

Sect.	Item	Qty.	Ref.	Part/value	Tolerance (%)	Voltage current	Watt	Technol. info.	Package	Manufacturer	Manufacturer code	More information
Battery	2	1	BT1	Support for Li-Ion battery					SMD	Keystone	3008	
	3	1	J6	SMD jumper				Pitch 100 mils	SMD	FCI	95293-101-03LF	This jumper allows the connection of the STORE pin to the voltage regulator U4 in case the external sampling is OFF
Supply	4	2	U3	Flexible PV panel					SMD	SANYO	AM-1801	2 PV panels connected in series
	5	1	J4	SMD jumper				Pitch 100 mils	SMD	FCI	95293-101-03LF	This jumper disconnects the PV panel U3 in case an alternative supply is required and connected to CN1
	6	1	J5	3-way switch				Pitch 100 mils	SMD	FCI	95293-101-03LF	This jumper allows the connection of the source to the harvester U1 in case the external sampling is OFF
	6	1	CN1	2-way conn.				Pitch 100 mils	SMD	FCI	95293-101-03LF	Input connector for external PV panel or TEG



Table 1. Harvesting module BOM (continued)

Sect.	Item	Qty.	Ref.	Part/value	Tolerance (%)	Voltage current	Watt	Technol. info.	Package	Manufacturer	Manufacturer code	More information	
Harvester/DC-DC controller section	MPPT section	7	1	U2	SPV1050					ST		Harvester and thin film battery manager	
		8	1	C6	1 μ F	15%	25 V		X5R	0603	Murata	GRM188R61E105KA12D	Input capacitance
		9	1	Rmpp	10 M Ω	1%		0.1		0603	VISHAY	CRCW060310M0FKEA	Resistor partitioning for MPP track
		10	1	Rmpps	680 k Ω	1%		0.1		0603	TE Connectivity	CRG0603F680K	Resistor partitioning for MPP setting
		11	1	Rin	3 M Ω	0.01				0603	VISHAY	CRCW06033M00FKEA	Input resistor partitioning
		12	1	C34	10 nF	15%	16 V		X7R	0603	Murata	GRM188R71C103KA01D	Voltage sampling time constant capacitance
		13	1	L1	22 μ H	20%					Coilcraft	LPS4018-223ML_ LPS5010-223ML_ XFL2006-223ME_	DC-DC inductor
	LDO1	14	1	SW1	3-way switch				Pitch 100 mils	SMD	FCI	95293-101-04LF	Close 1 - 2, LDO1 is disabled Close 2 - 3, LDO1 controlled by external signal
		15	1	C5	100 nF	10%	6.3 V		X5R	0402	AVX	04026D104KAT2A	
	LDO2	16	1	SW2	3-way switch				Pitch 100 mils	SMD	FCI	95293-101-04LF	Close 1 - 2, LDO2 is disabled Close 2 - 3, LDO2 controlled by external signal
		17	1	C4	100 nF	10%	6.3 V		X5R	0402	AVX	04026D104KAT2A	



Table 1. Harvesting module BOM (continued)

Sect.	Item	Qty.	Ref.	Part/value	Tolerance (%)	Voltage current	Watt	Technol. info.	Package	Manufacturer	Manufacturer code	More information
Battery management section	18	2	C9, C10	47 μ F	20%	6.3 V		X5R	0805	KEMET	C0805C476M9PAC7800	Capacitor on STORE net
	20	1	Cuyp	470 nF	15%	10 V		X5R	0603	Murata	GRM188R71A474KA61D	UVP voltage sampling delay time constant capacitance
	21	1	Ruyp	6.8 M Ω	1%				0603	VISHAY	CRCW06036M80FKEA	VEOC = 4.15 V VUVP = 3.75 V
	22	1	Reoc	0.75 M Ω	1%				0603	VISHAY	CRCW0603750KFKEA	
	23	1	Rout	3 M Ω	1%				0603	VISHAY	CRCW06033M00FKEA	
Ambient light	24	1	U7	SFH5711					SMD	OSRAM	SFH 5711	Ambient light sensor: place on the same solder side of the PV panel (U3)
	25	1	R12	80 k Ω	1%		0.1		0603	VISHAY	CRCW060382K0FKEA	
	26	1	J7	SMD jumper				Pitch 100 mils	SMD	FCI	95293-101-03LF	
External supply from USB	27	1	U8	STLQ50C-R					SOT323-5L	ST	STLQ50C-R	
	28	1	SB49	5.36 k Ω			0.1		0603	Panasonic	ERA3AEB5361V	
	29	1	SB50	2.05 k Ω	\pm 1%		0.1		0603	VISHAY	CRCW06032K05FKEA	
	30	2	C14, C15	1 μ F	15%	25 V		X5R	0603	Murata	GRM188R61E105KA12D	
	32	1	J23	SMD jumper				Pitch 100 mils	SMD	FCI	95293-101-03LF	Disable charging from USB



Table 1. Harvesting module BOM (continued)

Sect.	Item	Qty.	Ref.	Part/value	Tolerance (%)	Voltage current	Watt	Technol. info.	Package	Manufacturer	Manufacturer code	More information
External connections	33	1	J28	Micro-USB					SMD	Molex	47346-0001	μC supply connector
	34	1	J25	16-pin conn.				2.54 mm	SDM	Samtec	SMH-108-02-G-D	Connector for future extensions
	35	1	J27	16-pin conn.				2.54 mm	SMD	Samtec	SMH-108-02-G-D	Connector for sampling
Spacers + nuts	36	4	Screw support							RS		

2 Layout

Figure 2. Layout - top view

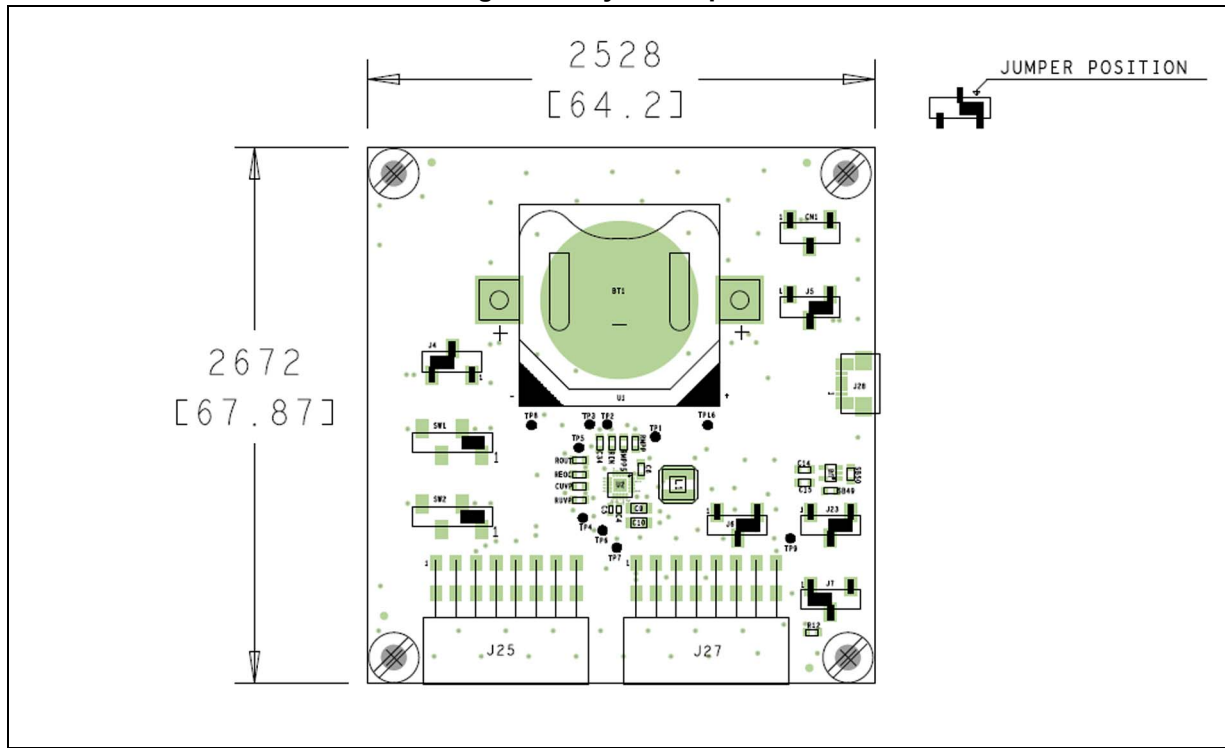
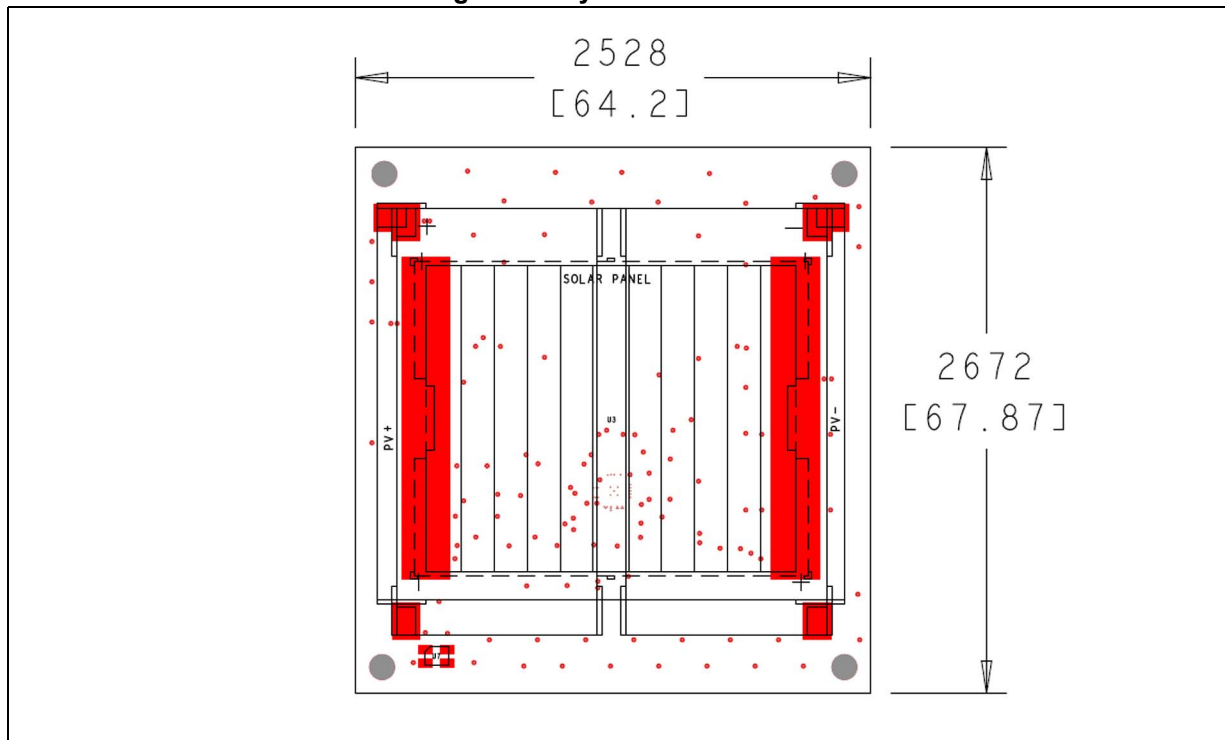

Figure 3. Layout - bottom view



3 Revision history

Table 2. Document revision history

Date	Revision	Changes
28-Nov-2013	1	Initial release.

Please Read Carefully:

Information in this document is provided solely in connection with ST products. STMicroelectronics NV and its subsidiaries ("ST") reserve the right to make changes, corrections, modifications or improvements, to this document, and the products and services described herein at any time, without notice.

All ST products are sold pursuant to ST's terms and conditions of sale.

Purchasers are solely responsible for the choice, selection and use of the ST products and services described herein, and ST assumes no liability whatsoever relating to the choice, selection or use of the ST products and services described herein.

No license, express or implied, by estoppel or otherwise, to any intellectual property rights is granted under this document. If any part of this document refers to any third party products or services it shall not be deemed a license grant by ST for the use of such third party products or services, or any intellectual property contained therein or considered as a warranty covering the use in any manner whatsoever of such third party products or services or any intellectual property contained therein.

UNLESS OTHERWISE SET FORTH IN ST'S TERMS AND CONDITIONS OF SALE ST DISCLAIMS ANY EXPRESS OR IMPLIED WARRANTY WITH RESPECT TO THE USE AND/OR SALE OF ST PRODUCTS INCLUDING WITHOUT LIMITATION IMPLIED WARRANTIES OF MERCHANTABILITY, FITNESS FOR A PARTICULAR PURPOSE (AND THEIR EQUIVALENTS UNDER THE LAWS OF ANY JURISDICTION), OR INFRINGEMENT OF ANY PATENT, COPYRIGHT OR OTHER INTELLECTUAL PROPERTY RIGHT.

ST PRODUCTS ARE NOT DESIGNED OR AUTHORIZED FOR USE IN: (A) SAFETY CRITICAL APPLICATIONS SUCH AS LIFE SUPPORTING, ACTIVE IMPLANTED DEVICES OR SYSTEMS WITH PRODUCT FUNCTIONAL SAFETY REQUIREMENTS; (B) AERONAUTIC APPLICATIONS; (C) AUTOMOTIVE APPLICATIONS OR ENVIRONMENTS, AND/OR (D) AEROSPACE APPLICATIONS OR ENVIRONMENTS. WHERE ST PRODUCTS ARE NOT DESIGNED FOR SUCH USE, THE PURCHASER SHALL USE PRODUCTS AT PURCHASER'S SOLE RISK, EVEN IF ST HAS BEEN INFORMED IN WRITING OF SUCH USAGE, UNLESS A PRODUCT IS EXPRESSLY DESIGNATED BY ST AS BEING INTENDED FOR "AUTOMOTIVE, AUTOMOTIVE SAFETY OR MEDICAL" INDUSTRY DOMAINS ACCORDING TO ST PRODUCT DESIGN SPECIFICATIONS. PRODUCTS FORMALLY ESCC, QML OR JAN QUALIFIED ARE DEEMED SUITABLE FOR USE IN AEROSPACE BY THE CORRESPONDING GOVERNMENTAL AGENCY.

Resale of ST products with provisions different from the statements and/or technical features set forth in this document shall immediately void any warranty granted by ST for the ST product or service described herein and shall not create or extend in any manner whatsoever, any liability of ST.

ST and the ST logo are trademarks or registered trademarks of ST in various countries.

Information in this document supersedes and replaces all information previously supplied.

The ST logo is a registered trademark of STMicroelectronics. All other names are the property of their respective owners.

© 2013 STMicroelectronics - All rights reserved

STMicroelectronics group of companies

Australia - Belgium - Brazil - Canada - China - Czech Republic - Finland - France - Germany - Hong Kong - India - Israel - Italy - Japan - Malaysia - Malta - Morocco - Philippines - Singapore - Spain - Sweden - Switzerland - United Kingdom - United States of America

www.st.com