



# STD5N95K3, STF5N95K3 STP5N95K3, STU5N95K3

N-channel 950 V, 3 Ω, 4 A, DPAK, TO-220, TO-220FP, IPAK  
Zener-protected SuperMESH3™ Power MOSFET

## Features

Type	V <sub>DSS</sub>	R <sub>DS(on)</sub> max	I <sub>D</sub>	P <sub>w</sub>
STD5N95K3	950 V	< 3.5 Ω	4 A	90 W
STF5N95K3	950 V	< 3.5 Ω	4 A	25 W
STP5N95K3	950 V	< 3.5 Ω	4 A	90 W
STU5N95K3	950 V	< 3.5 Ω	4 A	90 W

- 100% avalanche tested
- Extremely large avalanche performance
- Gate charge minimized
- Very low intrinsic capacitances
- Zener-protected

## Application

- Switching applications

## Description

The new SuperMESH3™ series of power MOSFETS is the result of the fine-tuning of ST's well-established strip-based PowerMESH™ layout with a new optimized vertical structure. The innovative design offer significantly reduced on-resistance, exceptional dynamic performance and very large avalanche capability, making the device suitable for the most demanding applications.

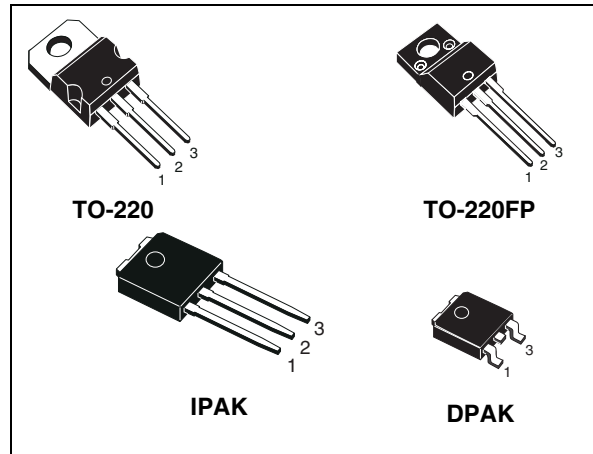

Figure 1. Internal schematic diagram

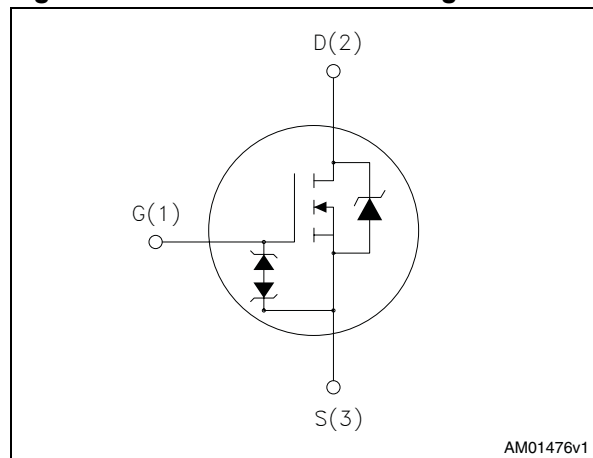

Table 1. Device summary

Order codes	Marking	Packages	Packaging
STD5N95K3	5N95K3	DPAK	Tape and reel
STF5N95K3	5N95K3	TO-220FP	Tube
STP5N95K3	5N95K3	TO-220	Tube
STU5N95K3	5N95K3	IPAK	Tube

# Contents

<b>1</b>	<b>Electrical ratings</b> .....	<b>3</b>
<b>2</b>	<b>Electrical characteristics</b> .....	<b>4</b>
2.1	Electrical characteristics (curves) .....	6
<b>3</b>	<b>Test circuits</b> .....	<b>9</b>
<b>4</b>	<b>Package mechanical data</b> .....	<b>10</b>
<b>5</b>	<b>Packaging mechanical data</b> .....	<b>15</b>
<b>6</b>	<b>Revision history</b> .....	<b>16</b>

# 1 Electrical ratings

**Table 2. Absolute maximum ratings**

Symbol	Parameter	Value				Unit
		TO-220	TO-220FP	IPAK	DPAK	
$V_{GS}$	Gate- source voltage	30				V
$I_D$	Drain current (continuous) at $T_C = 25\text{ °C}$	4	4 <sup>(1)</sup>	4		A
$I_D$	Drain current (continuous) at $T_C = 100\text{ °C}$	3	3 <sup>(1)</sup>	3		A
$I_{DM}^{(2)}$	Drain current (pulsed)	16	16 <sup>(1)</sup>	16		A
$P_{TOT}$	Total dissipation at $T_C = 25\text{ °C}$	90	25	90		W
$I_{AR}$	Avalanche current, repetitive or not-repetitive (pulse width limited by $T_J$ max)	4				A
$E_{AS}$	Single pulse avalanche energy (starting $T_J = 25\text{ °C}$ , $I_D = I_{AR}$ , $V_{DD} = 50\text{ V}$ )	100				mJ
$dv/dt^{(3)}$	Peak diode recovery voltage slope	5				V/ns
$V_{ISO}$	Insulation withstand voltage (AC)		2500			
$T_J$ $T_{stg}$	Operating junction temperature Storage temperature	-55 to 150				°C

1. Limited only by maximum temperature allowed
2. Pulse width limited by safe operating area
3.  $I_{SD} \leq 4\text{ A}$ ,  $di/dt \leq 100\text{ A}/\mu\text{s}$ , peak  $V_{DS} \leq V_{(BR)DSS}$

**Table 3. Thermal data**

Symbol	Parameter	Value				Unit
		TO-220	TO-220FP	IPAK	DPAK	
$R_{thj-case}$	Thermal resistance junction-case max	1.39	5	1.39		°C/W
$R_{thj-amb}$	Thermal resistance junction-ambient max	62.50		100		°C/W
$R_{thj-pcb}^{(1)}$	Thermal resistance junction-pcb max				50	°C/W
$T_J$	Maximum lead temperature for soldering purpose	300				°C/W

1. When mounted on 1inch² FR-4 board, 2 oz Cu

## 2 Electrical characteristics

(T<sub>case</sub> = 25 °C unless otherwise specified)

**Table 4. On /off states**

Symbol	Parameter	Test conditions	Min.	Typ.	Max.	Unit
V <sub>(BR)DSS</sub>	Drain-source breakdown voltage	I <sub>D</sub> = 1 mA, V <sub>GS</sub> = 0	950			V
I <sub>DSS</sub>	Zero gate voltage drain current (V <sub>GS</sub> = 0)	V <sub>DS</sub> = Max rating V <sub>DS</sub> = Max rating, T <sub>C</sub> = 125 °C			1 50	μA μA
I <sub>GSS</sub>	Gate-body leakage current (V <sub>DS</sub> = 0)	V <sub>GS</sub> = ± 20 V; V <sub>DS</sub> = 0			10	μA
V <sub>GS(th)</sub>	Gate threshold voltage	V <sub>DS</sub> = V <sub>GS</sub> , I <sub>D</sub> = 100 μA	3	4	5	V
R <sub>DS(on)</sub>	Static drain-source on resistance	V <sub>GS</sub> = 10 V, I <sub>D</sub> = 2 A		3	3.5	Ω

**Table 5. Dynamic**

Symbol	Parameter	Test conditions	Min.	Typ.	Max.	Unit
C <sub>iss</sub> C <sub>oss</sub> C <sub>rss</sub>	Input capacitance Output capacitance Reverse transfer capacitance	V <sub>DS</sub> = 25 V, f = 1 MHz, V <sub>GS</sub> = 0	-	460 38 1	-	pF pF pF
C <sub>o(tr)</sub> <sup>(1)</sup>	Equivalent capacitance time related	V <sub>DS</sub> = 0 to 760 V, V <sub>GS</sub> = 0	-	970	-	pF
C <sub>o(er)</sub> <sup>(2)</sup>	Equivalent capacitance energy related	V <sub>DS</sub> = 0 to 760 V, V <sub>GS</sub> = 0	-	15	-	pF
R <sub>g</sub>	Gate input resistance	f = 1 MHz open drain	-	5.5	-	Ω
Q <sub>g</sub> Q <sub>gs</sub> Q <sub>gd</sub>	Total gate charge Gate-source charge Gate-drain charge	V <sub>DD</sub> = 760 V, I <sub>D</sub> = 4 A, V <sub>GS</sub> = 10 V (see Figure 20)	-	19 4.7 12	-	nC nC nC

1. Time related is defined as a constant equivalent capacitance giving the same charging time as C<sub>oss</sub> when V<sub>DS</sub> increases from 0 to 80% V<sub>DSS</sub>
2. Energy related is defined as a constant equivalent capacitance giving the same stored energy as C<sub>oss</sub> when V<sub>DS</sub> increases from 0 to 80% V<sub>DSS</sub>

**Table 6. Switching times**

Symbol	Parameter	Test conditions	Min.	Typ.	Max	Unit
$t_{d(on)}$	Turn-on delay time	$V_{DD} = 475\text{ V}$ , $I_D = 2\text{ A}$ , $R_G = 4.7\ \Omega$ , $V_{GS} = 10\text{ V}$ <i>(see Figure 19)</i>		17		ns
$t_r$	Rise time			7		ns
$t_{d(off)}$	Turn-off-delay time			32		ns
$t_f$	Fall time			18		ns

**Table 7. Source drain diode**

Symbol	Parameter	Test conditions	Min.	Typ.	Max	Unit
$I_{SD}$	Source-drain current				4	A
$I_{SDM}^{(1)}$	Source-drain current (pulsed)		-		16	A
$V_{SD}^{(2)}$	Forward on voltage	$I_{SD} = 4\text{ A}$ , $V_{GS} = 0$	-		1.6	V
$t_{rr}$	Reverse recovery time	$I_{SD} = 4\text{ A}$ , $di/dt = 100\text{ A}/\mu\text{s}$		410		ns
$Q_{rr}$	Reverse recovery charge	$V_{DD} = 60\text{ V}$	-	3.5		$\mu\text{C}$
$I_{RRM}$	Reverse recovery current	<i>(see Figure 21)</i>		17		A
$t_{rr}$	Reverse recovery time	$I_{SD} = 4\text{ A}$ , $di/dt = 100\text{ A}/\mu\text{s}$		516		ns
$Q_{rr}$	Reverse recovery charge	$V_{DD} = 60\text{ V}$ $T_J = 150\text{ }^\circ\text{C}$	-	4.1		$\mu\text{C}$
$I_{RRM}$	Reverse recovery current	<i>(see Figure 21)</i>		16		A

1. Pulse width limited by safe operating area
2. Pulsed: pulse duration = 300  $\mu\text{s}$ , duty cycle 1.5%

**Table 8. Gate-source Zener diode**

Symbol	Parameter	Test conditions	Min.	Typ.	Max.	Unit
$BV_{GSO}$	Gate-source breakdown voltage	$I_{gs} = \pm 1\text{ mA}$ (open drain)	30		-	V

The built-in back-to-back Zener diodes have specifically been designed to enhance not only the device’s ESD capability, but also to make them safely absorb possible voltage transients that may occasionally be applied from gate to source. In this respect the Zener voltage is appropriate to achieve an efficient and cost-effective intervention to protect the device’s integrity. These integrated Zener diodes thus avoid the usage of external components.

## 2.1 Electrical characteristics (curves)

Figure 2. Safe operating area for TO-220

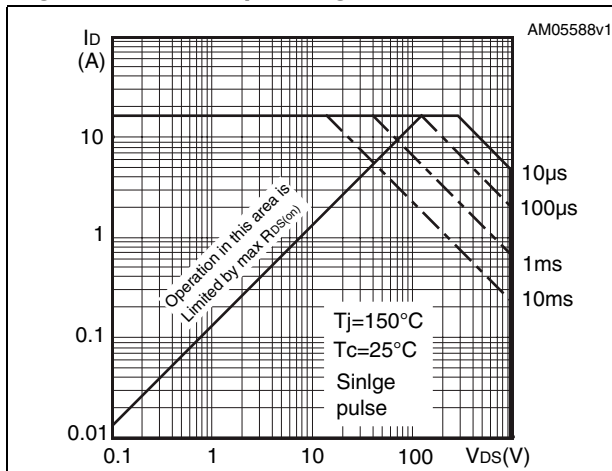

Figure 3. Thermal impedance for TO-220

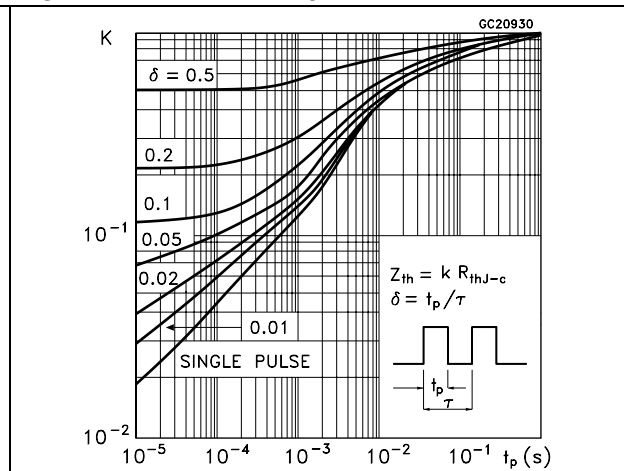

Figure 4. Safe operating area for TO-220FP

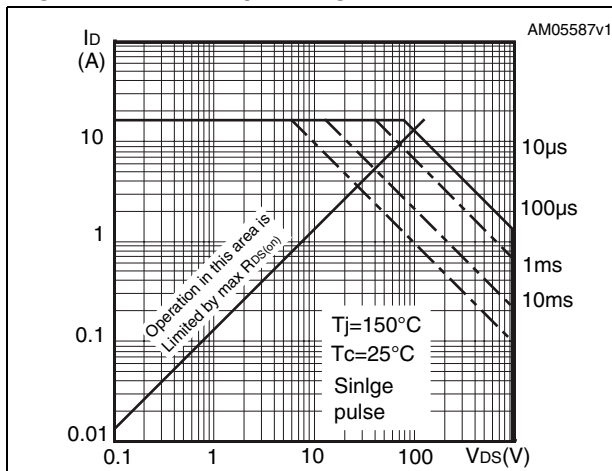

Figure 5. Thermal impedance for TO-220FP

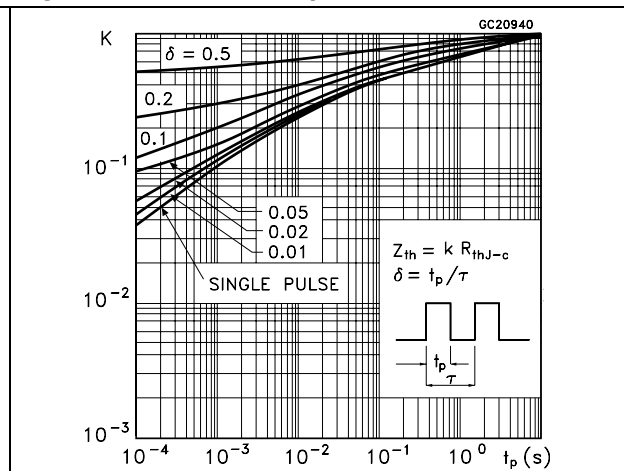

Figure 6. Safe operating area for IPAK, DPAK

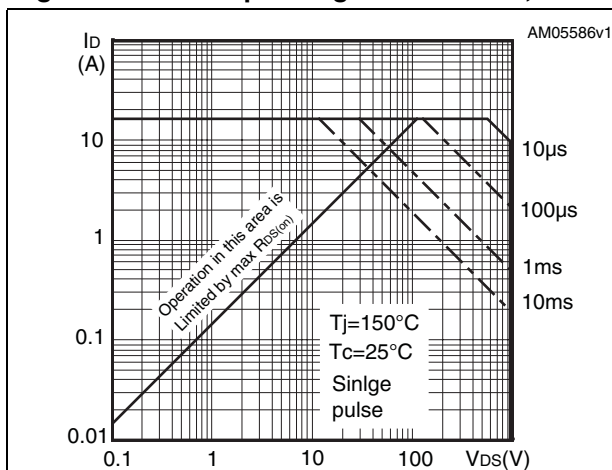

Figure 7. Thermal impedance for IPAK, DPAK

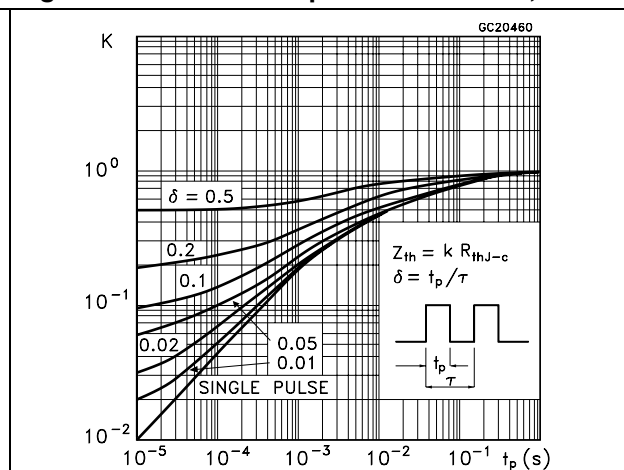

Figure 8. Output characteristics

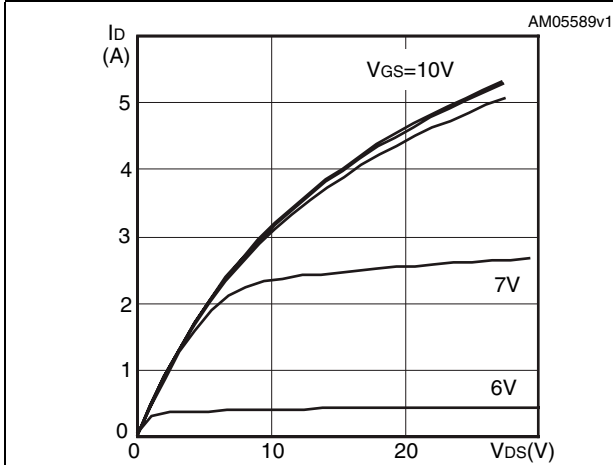

Figure 9. Transfer characteristics

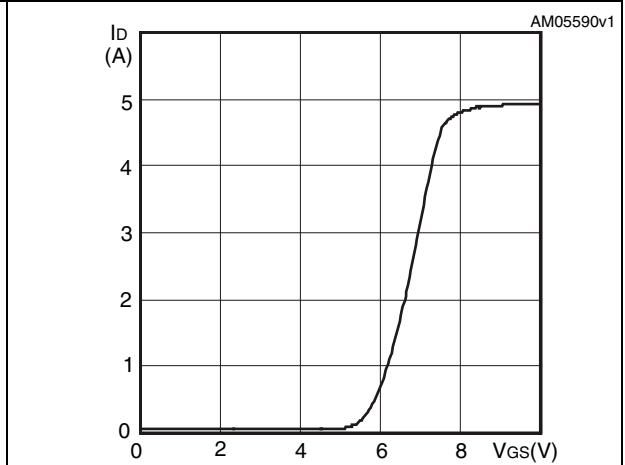

Figure 10. Gate charge vs gate-source voltage Figure 11. Static drain-source on resistance

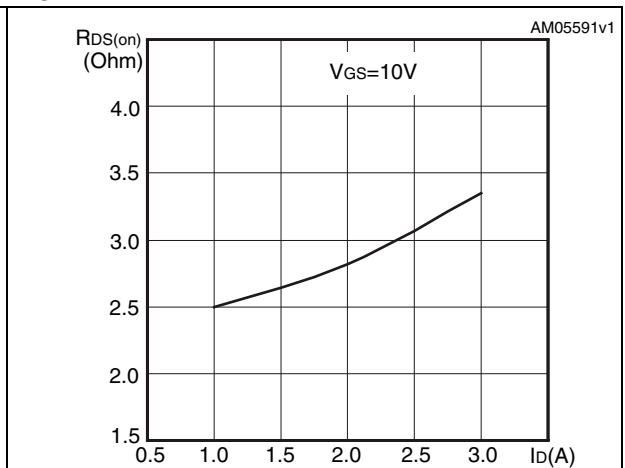
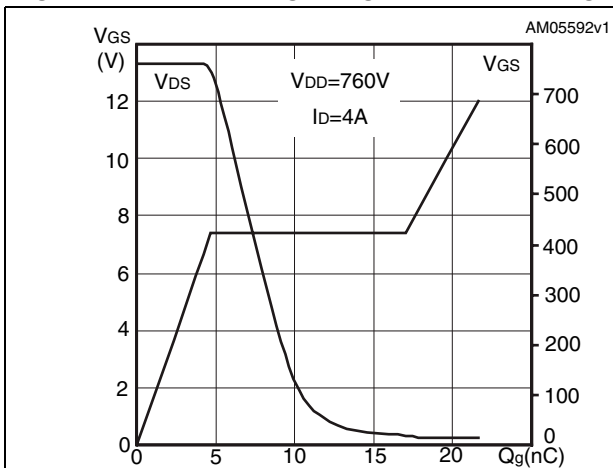

Figure 12. Capacitance variations

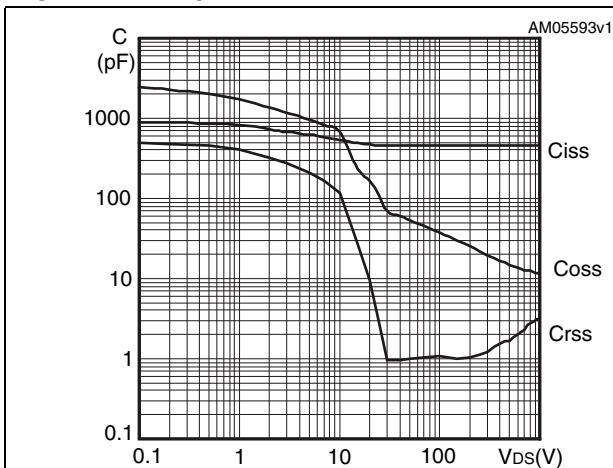

Figure 13. Output capacitance stored energy

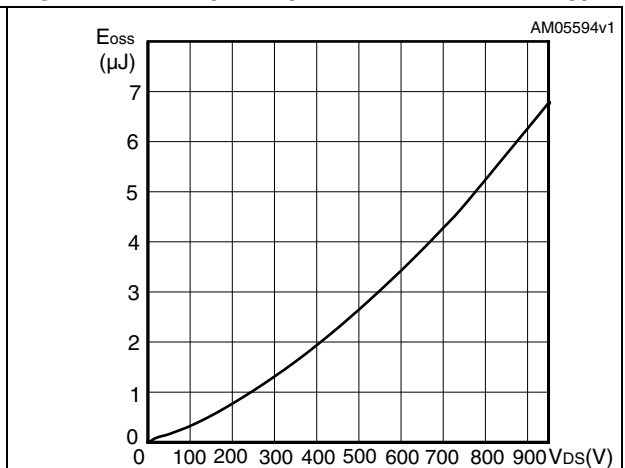

Figure 14. Normalized gate threshold voltage vs temperature

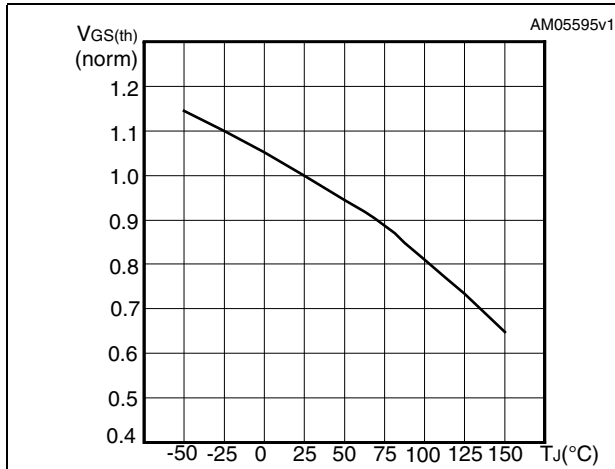

Figure 15. Normalized on resistance vs temperature

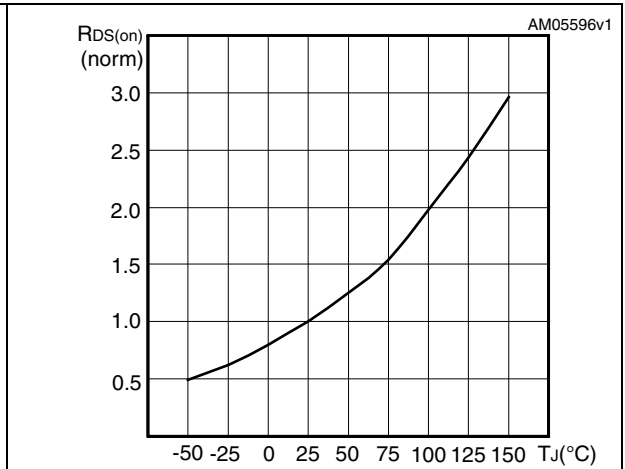

Figure 16. Source-drain diode forward characteristics

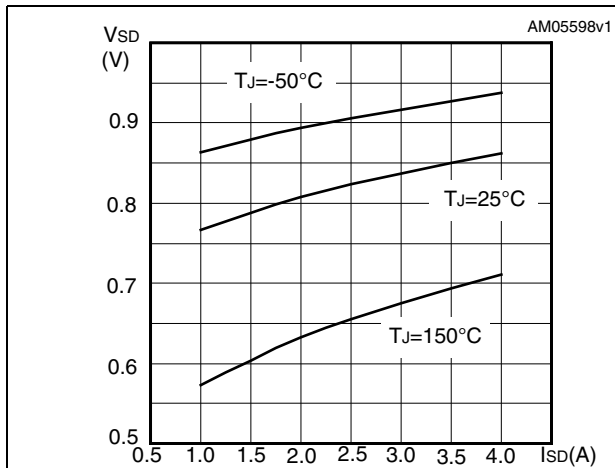

Figure 17. Normalized BV<sub>DSS</sub> vs temperature

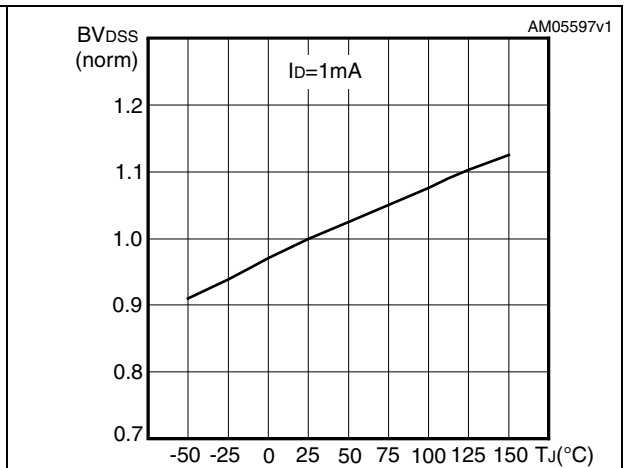
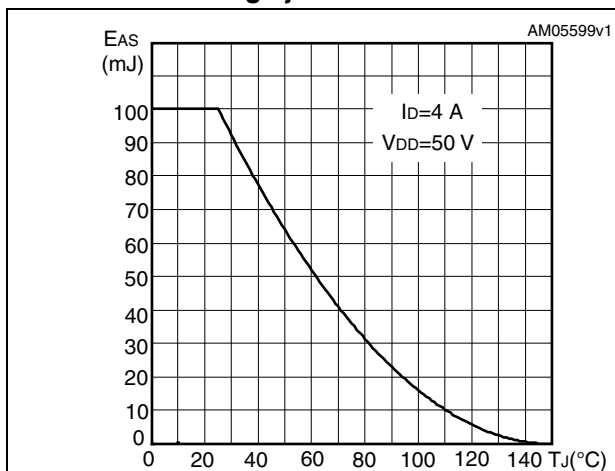
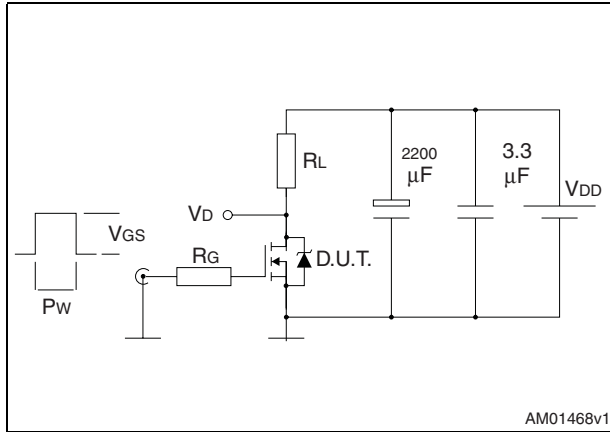

Figure 18. Maximum avalanche energy vs starting Tj



### 3 Test circuits

**Figure 19. Switching times test circuit for resistive load**



AM01468v1

**Figure 20. Gate charge test circuit**

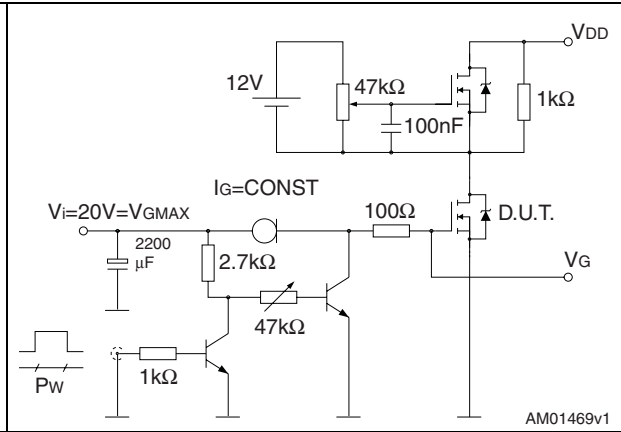

AM01469v1

**Figure 21. Test circuit for inductive load switching and diode recovery times**

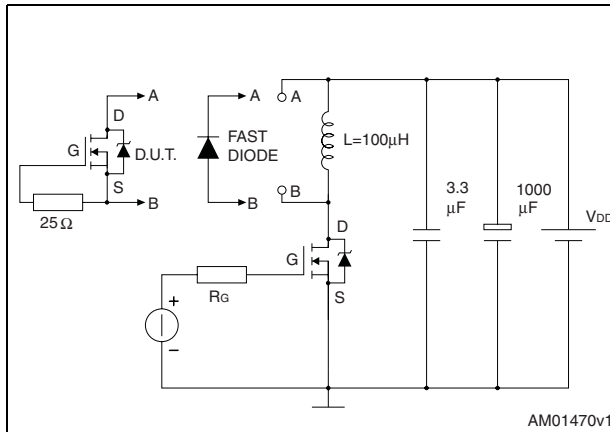

AM01470v1

**Figure 22. Unclamped inductive load test circuit**

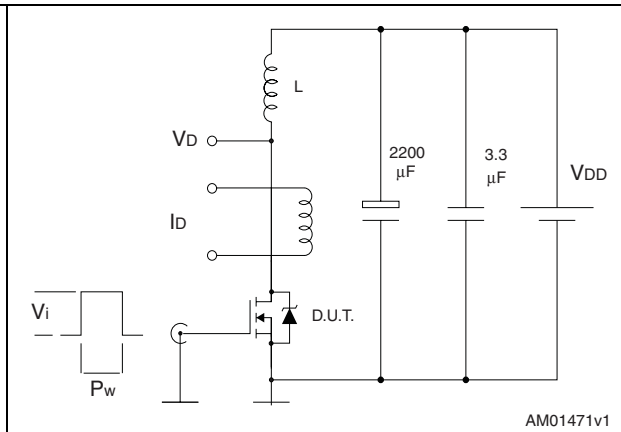

AM01471v1

**Figure 23. Unclamped inductive waveform**

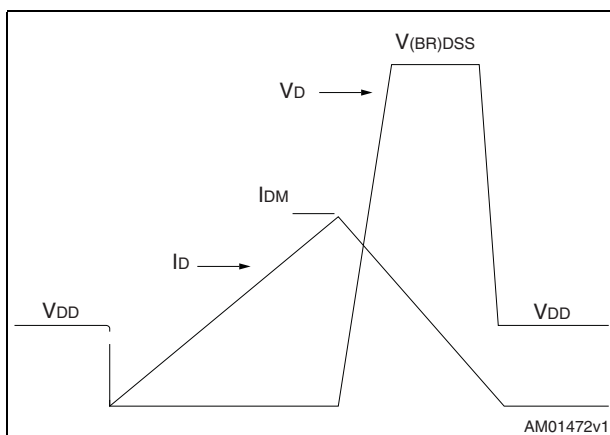

AM01472v1

**Figure 24. Switching time waveform**

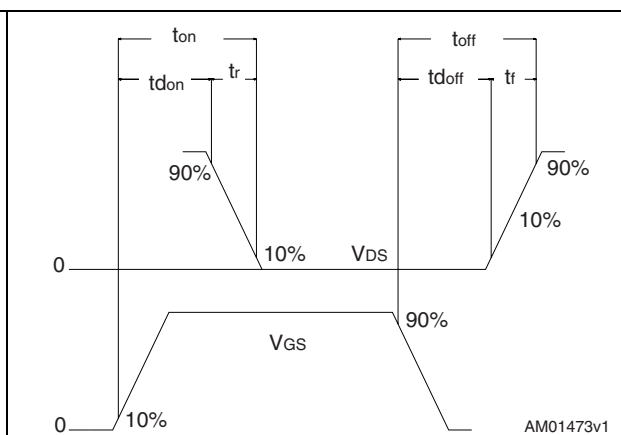

AM01473v1

## 4 Package mechanical data

In order to meet environmental requirements, ST offers these devices in different grades of ECOPACK<sup>®</sup> packages, depending on their level of environmental compliance. ECOPACK<sup>®</sup> specifications, grade definitions and product status are available at: [www.st.com](http://www.st.com). ECOPACK is an ST trademark.

Table 9. TO-220FP mechanical data

Dim.	mm		
	Min.	Typ.	Max.
A	4.4		4.6
B	2.5		2.7
D	2.5		2.75
E	0.45		0.7
F	0.75		1
F1	1.15		1.70
F2	1.15		1.70
G	4.95		5.2
G1	2.4		2.7
H	10		10.4
L2		16	
L3	28.6		30.6
L4	9.8		10.6
L5	2.9		3.6
L6	15.9		16.4
L7	9		9.3
Dia	3		3.2

Figure 25. TO-220FP drawing

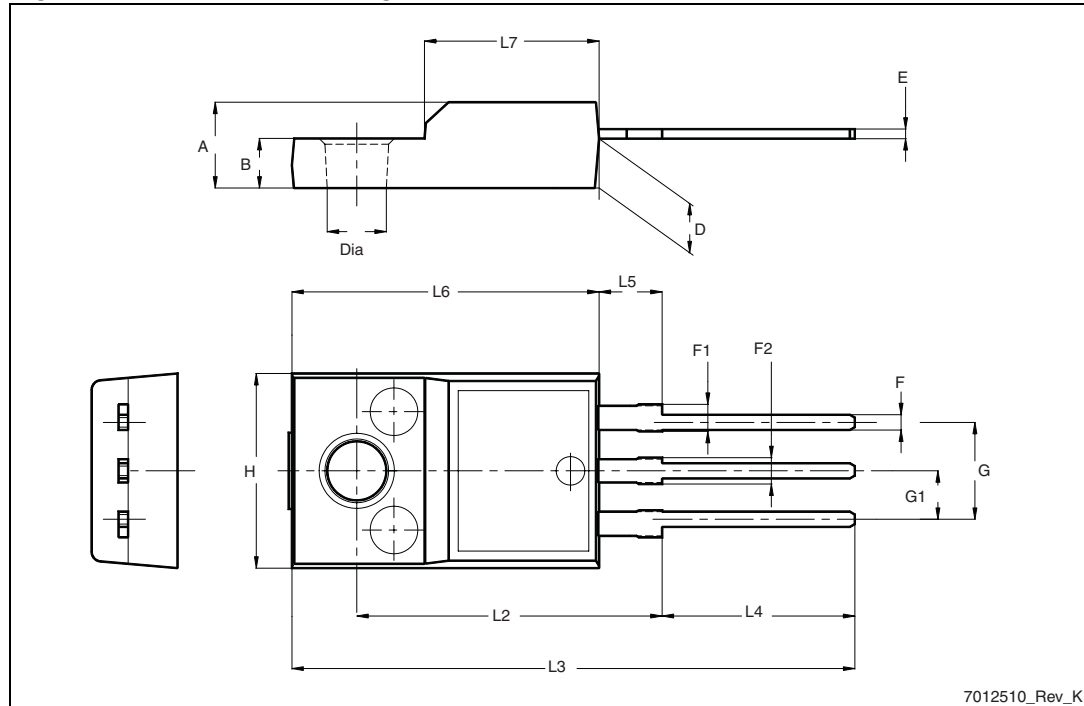

7012510\_Rev\_K

TO-252 (DPAK) mechanical data

DIM.	mm.		
	min.	typ	max.
A	2.20		2.40
A1	0.90		1.10
A2	0.03		0.23
b	0.64		0.90
b4	5.20		5.40
c	0.45		0.60
c2	0.48		0.60
D	6.00		6.20
D1		5.10	
E	6.40		6.60
E1		4.70	
e		2.28	
e1	4.40		4.60
H	9.35		10.10
L	1		
L1		2.80	
L2		0.80	
L4	0.60		1
R		0.20	
V2	0°		8°

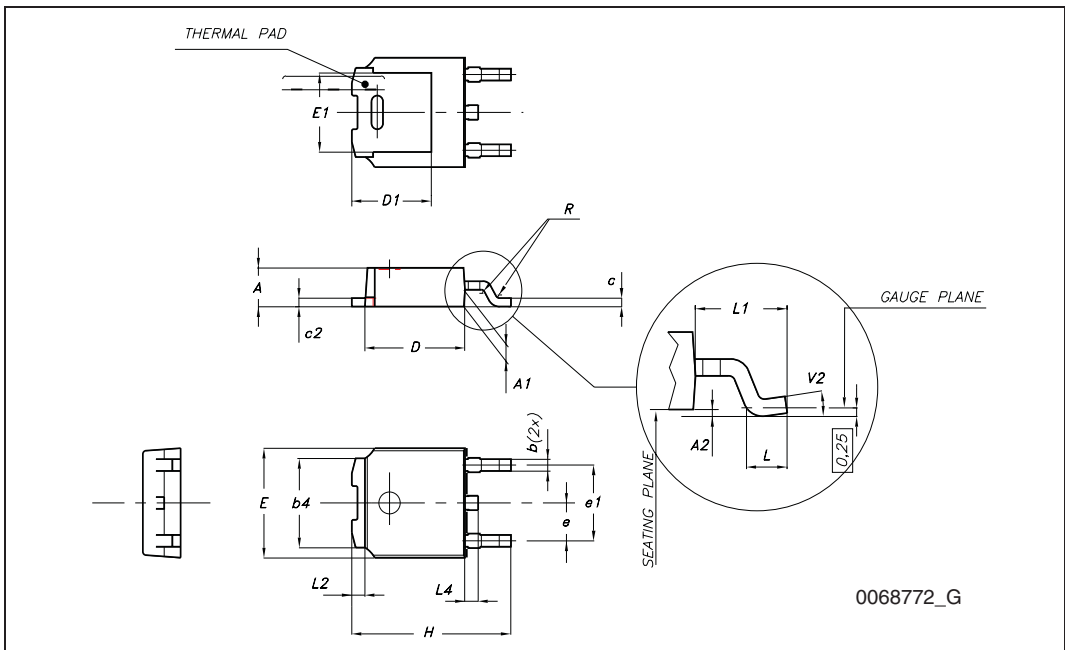

TO-220 type A mechanical data

Dim	mm		
	Min	Typ	Max
A	4.40		4.60
b	0.61		0.88
b1	1.14		1.70
c	0.48		0.70
D	15.25		15.75
D1		1.27	
E	10		10.40
e	2.40		2.70
e1	4.95		5.15
F	1.23		1.32
H1	6.20		6.60
J1	2.40		2.72
L	13		14
L1	3.50		3.93
L20		16.40	
L30		28.90	
∅P	3.75		3.85
Q	2.65		2.95

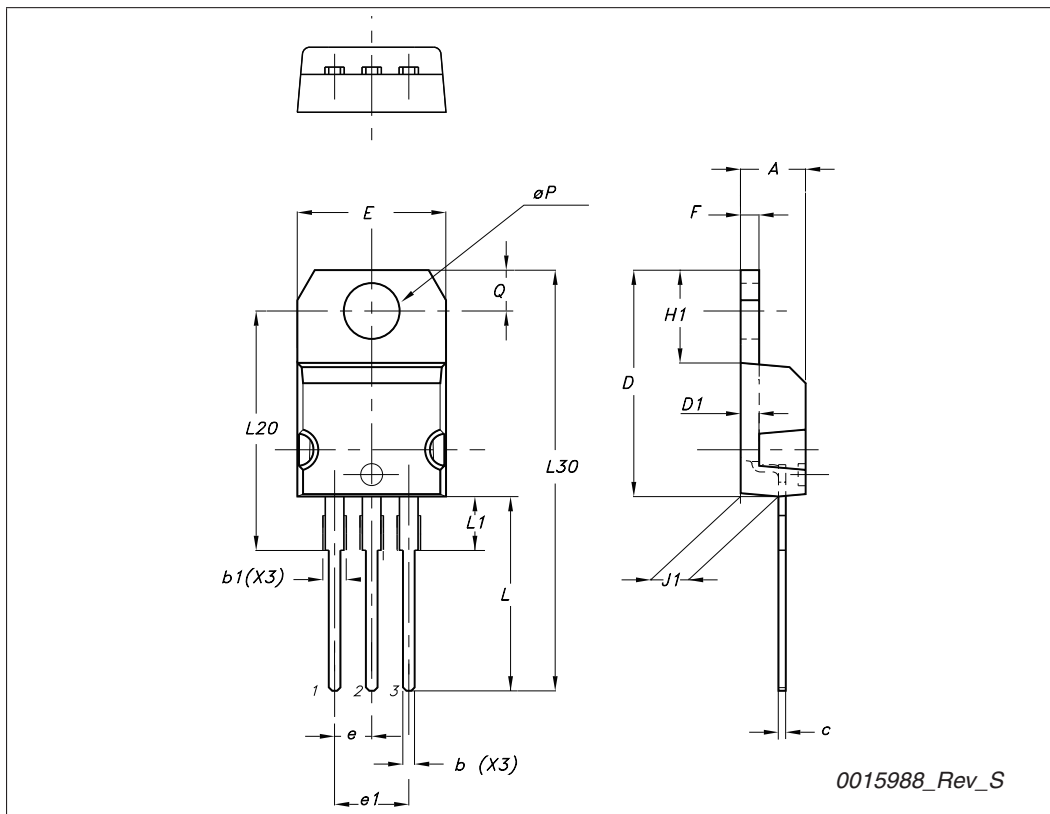

**TO-251 (IPAK) mechanical data**

DIM.	mm.		
	min.	typ	max.
A	2.20		2.40
A1	0.90		1.10
b	0.64		0.90
b2			0.95
b4	5.20		5.40
c	0.45		0.60
c2	0.48		0.60
D	6.00		6.20
E	6.40		6.60
e		2.28	
e1	4.40		4.60
H		16.10	
L	9.00		9.40
(L1)	0.80		1.20
L2		0.80	
V1		10°	

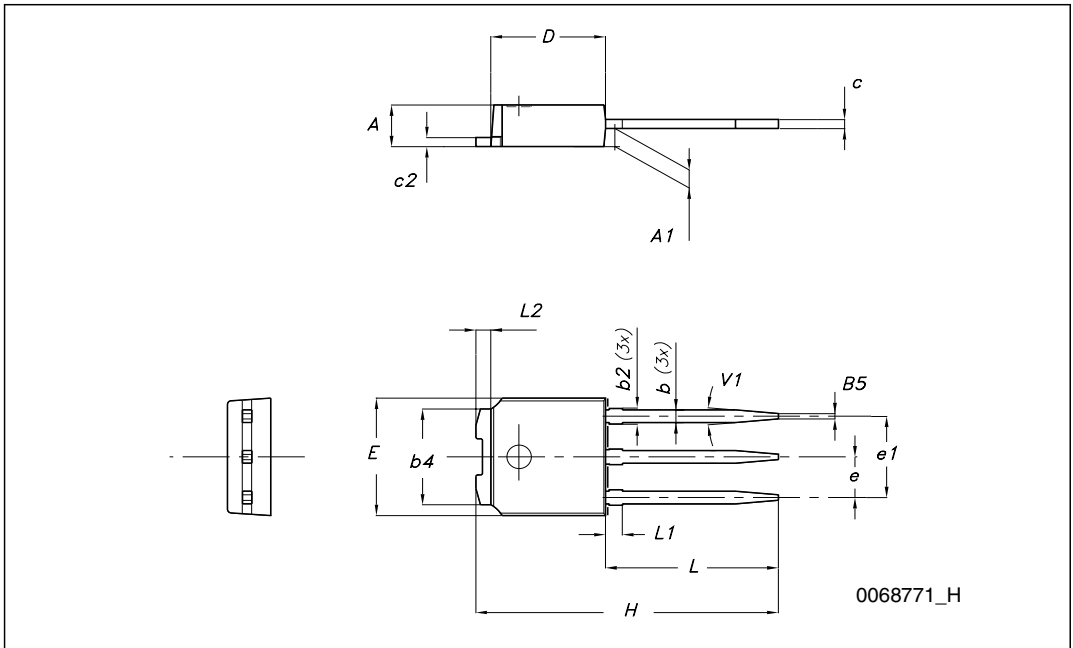

# 5 Packaging mechanical data

## DPAK FOOTPRINT

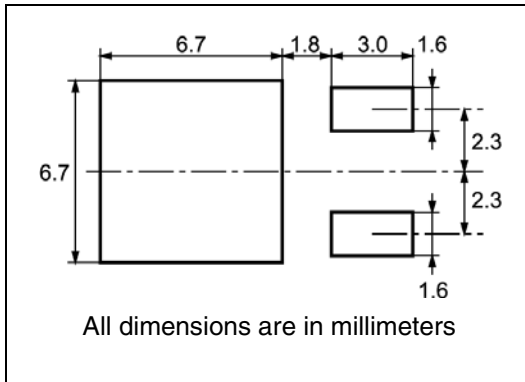

## TAPE AND REEL SHIPMENT

40 mm min. Access hole at slot location

Full radius

Tape slot in core for tape start 2.5mm min. width

G measured at hub

### REEL MECHANICAL DATA

DIM.	mm		inch	
	MIN.	MAX.	MIN.	MAX.
A		330		12.992
B	1.5		0.059	
C	12.8	13.2	0.504	0.520
D	20.2		0.795	
G	16.4	18.4	0.645	0.724
N	50		1.968	
T		22.4		0.881

BASE QTY	BULK QTY
2500	2500

### TAPE MECHANICAL DATA

DIM.	mm		inch	
	MIN.	MAX.	MIN.	MAX.
A0	6.8	7	0.267	0.275
B0	10.4	10.6	0.409	0.417
B1		12.1		0.476
D	1.5	1.6	0.059	0.063
D1	1.5		0.059	
E	1.65	1.85	0.065	0.073
F	7.4	7.6	0.291	0.299
K0	2.55	2.75	0.100	0.108
P0	3.9	4.1	0.153	0.161
P1	7.9	8.1	0.311	0.319
P2	1.9	2.1	0.075	0.082
R	40		1.574	
W	15.7	16.3	0.618	0.641

TOP COVER TAPE

10 pitches cumulative tolerance on tape +/- 0.2 mm

Center line of cavity

User Direction of Feed

FEED DIRECTION

TRL

Bending radius R min.

For machine ref. only including draft and radii concentric around B0

## 6 Revision history

**Table 10. Document revision history**

Date	Revision	Changes
12-May-2009	1	First release
11-Dec-2009	2	Document status promoted from preliminary data to datasheet

**Please Read Carefully:**

Information in this document is provided solely in connection with ST products. STMicroelectronics NV and its subsidiaries ("ST") reserve the right to make changes, corrections, modifications or improvements, to this document, and the products and services described herein at any time, without notice.

All ST products are sold pursuant to ST's terms and conditions of sale.

Purchasers are solely responsible for the choice, selection and use of the ST products and services described herein, and ST assumes no liability whatsoever relating to the choice, selection or use of the ST products and services described herein.

No license, express or implied, by estoppel or otherwise, to any intellectual property rights is granted under this document. If any part of this document refers to any third party products or services it shall not be deemed a license grant by ST for the use of such third party products or services, or any intellectual property contained therein or considered as a warranty covering the use in any manner whatsoever of such third party products or services or any intellectual property contained therein.

**UNLESS OTHERWISE SET FORTH IN ST'S TERMS AND CONDITIONS OF SALE ST DISCLAIMS ANY EXPRESS OR IMPLIED WARRANTY WITH RESPECT TO THE USE AND/OR SALE OF ST PRODUCTS INCLUDING WITHOUT LIMITATION IMPLIED WARRANTIES OF MERCHANTABILITY, FITNESS FOR A PARTICULAR PURPOSE (AND THEIR EQUIVALENTS UNDER THE LAWS OF ANY JURISDICTION), OR INFRINGEMENT OF ANY PATENT, COPYRIGHT OR OTHER INTELLECTUAL PROPERTY RIGHT.**

**UNLESS EXPRESSLY APPROVED IN WRITING BY AN AUTHORIZED ST REPRESENTATIVE, ST PRODUCTS ARE NOT RECOMMENDED, AUTHORIZED OR WARRANTED FOR USE IN MILITARY, AIR CRAFT, SPACE, LIFE SAVING, OR LIFE SUSTAINING APPLICATIONS, NOR IN PRODUCTS OR SYSTEMS WHERE FAILURE OR MALFUNCTION MAY RESULT IN PERSONAL INJURY, DEATH, OR SEVERE PROPERTY OR ENVIRONMENTAL DAMAGE. ST PRODUCTS WHICH ARE NOT SPECIFIED AS "AUTOMOTIVE GRADE" MAY ONLY BE USED IN AUTOMOTIVE APPLICATIONS AT USER'S OWN RISK.**

Resale of ST products with provisions different from the statements and/or technical features set forth in this document shall immediately void any warranty granted by ST for the ST product or service described herein and shall not create or extend in any manner whatsoever, any liability of ST.

ST and the ST logo are trademarks or registered trademarks of ST in various countries.

Information in this document supersedes and replaces all information previously supplied.

The ST logo is a registered trademark of STMicroelectronics. All other names are the property of their respective owners.

© 2009 STMicroelectronics - All rights reserved

STMicroelectronics group of companies

Australia - Belgium - Brazil - Canada - China - Czech Republic - Finland - France - Germany - Hong Kong - India - Israel - Italy - Japan - Malaysia - Malta - Morocco - Philippines - Singapore - Spain - Sweden - Switzerland - United Kingdom - United States of America

[www.st.com](http://www.st.com)