



STLQ015xx

150 mA, ultra-low quiescent current
linear voltage regulator

Features

- Input voltage from 1.5 to 5.5 V
- Very low quiescent current:
 - 1.0 μA (typ) at no load
 - 1.4 μA (typ) at 150 mA load
 - 1 nA (typ) in OFF mode
 - 200 nA max in OFF mode at 125 °C
- Output voltage tolerance: $\pm 2\%$ at 25 °C
- 150 mA guaranteed output current
- Wide range of output voltages: 0.8 V to 3.3 V in 100 mV steps
- Logic-controlled electronic shutdown
- Compatible with ceramic capacitor ($C_{\text{OUT}} = 1 \mu\text{F}$)
- Internal current and thermal limit
- Package: SOT666-6L
- Temperature range: -40 °C to 125 °C

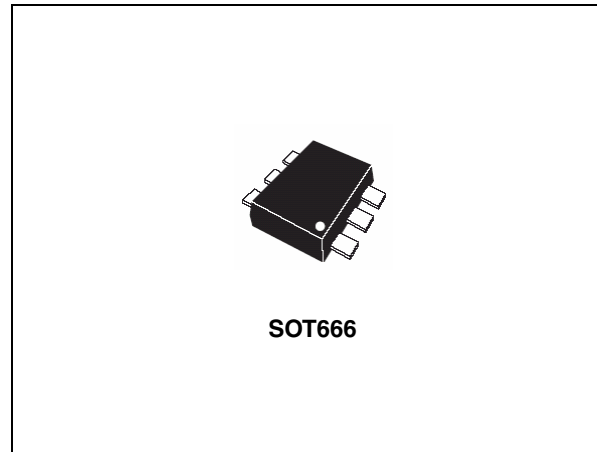

requiring very long standby time. The enable logic control function puts the STLQ015xx in shutdown mode, reducing total current consumption to 1 nA. The device also includes short-circuit constant-current limiting and thermal protection. Typical applications for the device are portable and battery-powered systems, electronic sensors, and microcontroller power supply.

Description

The STLQ015xx provides 150 mA of maximum current from an input voltage ranging from 1.5 V to 5.5 V, with a typical dropout voltage of 112 mV. The key feature of this device is its quiescent current, which is just 1.4 μA at maximum output current. The device is stable with a ceramic capacitor on the output. It offers very low quiescent current, extending battery life and making the device suitable for applications

Table 1. Device summary

| Part numbers | Order codes | Output voltages |
|--------------|--------------|-----------------|
| STLQ015XX25 | STLQ015XG25R | 2.5 V |
| STLQ015XX28 | STLQ015XG28R | 2.8 V |
| STLQ015XX30 | STLQ015XG30R | 3.0 V |
| STLQ015XX31 | STLQ015XG31R | 3.1 V |
| STLQ015XX33 | STLQ015XG33R | 3.3 V |

Contents

| | | |
|---|--|-----------|
| 1 | STLQ015xx block diagram | 3 |
| 2 | Pin configuration and description | 4 |
| 3 | Typical application | 5 |
| 4 | Maximum ratings | 6 |
| 5 | Electrical characteristics | 7 |
| 6 | Typical performance characteristics | 9 |
| 7 | Package mechanical data | 12 |
| 8 | Different output voltage versions of the STLQ015xx available on request | 15 |
| 9 | Revision history | 16 |

1 STLQ015xx block diagram

Figure 1. Device block diagram

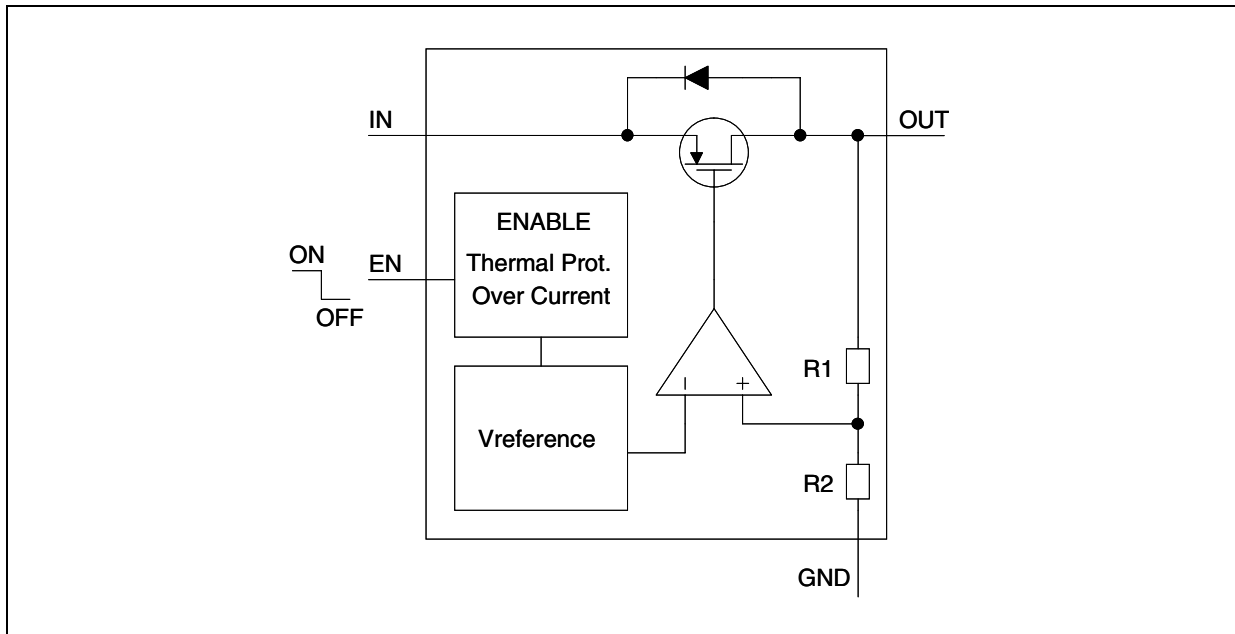

2 Pin configuration and description

Figure 2. Pin configuration (top view)

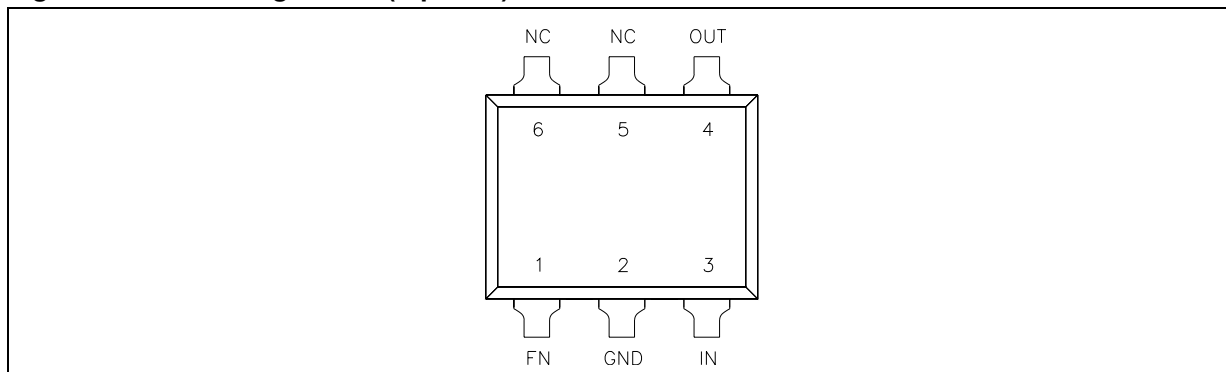
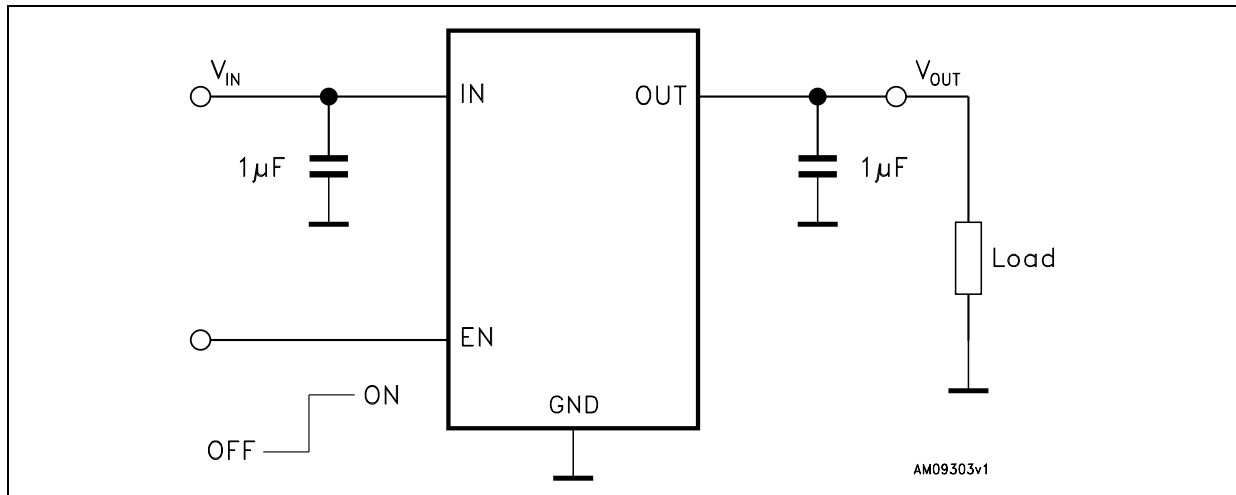

Table 2. Pin description

| Pin | Symbol | Function |
|-----|--------|---|
| 1 | EN | Enable input. Set V_{EN} = High to turn on the device. Set V_{EN} = Low to turn off the device. |
| 2 | GND | Ground |
| 3 | IN | Input voltage |
| 4 | OUT | Output voltage |
| 5 | NC | Not connected |
| 6 | NC | Not connected |

3 Typical application

Figure 3. Typical application circuit



4 Maximum ratings

Table 3. Absolute maximum ratings

| Symbol | Parameter | Value | Unit |
|-----------|---------------------------|-------------------------|------|
| V_{IN} | DC input voltage | -0.3 to 7 | V |
| V_{OUT} | DC output voltage | - 0.3 to $V_{IN} + 0.3$ | V |
| V_{EN} | Enable input voltage | - 0.3 to $V_{IN} + 0.3$ | V |
| I_{OUT} | Output current | Internally limited | mA |
| ESD | Human Body Model | ± 3 | kV |
| | Machine Model | ± 300 | V |
| P_D | Power dissipation | Internally limited | mW |
| T_{STG} | Storage temperature range | -65 to 150 | °C |
| T_{OP} | Max junction temperature | 150 | °C |

Note: Absolute maximum ratings are those values beyond which damage to the device may occur. Functional operation under these conditions is not implied. All values are referred to GND.

Table 4. Thermal data

| Symbol | Parameter | SOT666 | Unit |
|------------|-------------------------------------|--------|------|
| R_{thJA} | Thermal resistance junction-ambient | 132 | °C/W |
| R_{thJC} | Thermal resistance junction-case | 56 | °C/W |

5 Electrical characteristics

$T_J = 25\text{ }^\circ\text{C}$, $V_{IN} = V_{OUT(NOM)} + 1\text{ V}$, $C_{IN} = C_{OUT} = 1\text{ }\mu\text{F}$, $I_{OUT} = 1\text{ mA}$, $V_{EN} = V_{IN}$, unless otherwise specified.

Table 5. Electrical characteristics

| Symbol | Parameter | Test conditions | Min. | Typ. | Max. | Unit |
|-----------------------|---|--|------|-------------|------|---------------------|
| V_{IN} | Operating input voltage | $I_{OUT} = 0$ | 1.5 | | 5.5 | V |
| | | $-40^\circ\text{C} < T_J < 125^\circ\text{C}$, $I_{OUT} = 150\text{mA}$ | 1.55 | | 5.5 | |
| V_{OUT} | V_{OUT} accuracy | $I_{OUT} = 1\text{mA}$ | -2 | | 2 | % |
| | | $I_{OUT} = 1\text{mA}$, $V_{OUT} < 1\text{V}$ | -20 | | +20 | mV |
| | | $I_{OUT} = 1\text{mA}$, $-40^\circ\text{C} < T_J < 125^\circ\text{C}$ | -3 | | 3 | % |
| $\Delta V_{OUT-LINE}$ | Static line regulation | $V_{OUT} + 1\text{V} \leq V_{IN} \leq 5.5\text{V}$, $I_{OUT} = 1\text{mA}$ | | ± 0.01 | | %/V |
| $\Delta V_{OUT-LOAD}$ | Static load regulation | $I_{OUT} = 1\text{mA}$ to 150mA | | ± 0.002 | | %/mA |
| V_{DROP} | Dropout voltage ⁽¹⁾ | $I_{OUT} = 150\text{mA}$ | | 112 | | mV |
| | | $I_{OUT} = 150\text{mA}$, $-40^\circ\text{C} < T_J < 125^\circ\text{C}$ | | | 300 | |
| e_N | Output noise voltage | 10kHz to 100kHz, $I_{OUT} = 10\text{mA}$, $V_{OUT} = 0.8\text{V}$ | | 75 | | μV_{RMS} |
| SVR | Supply voltage rejection $V_{OUT} = 0.8\text{V}$ | $V_{IN} = V_{OUTNOM} + 1\text{V} \pm V_{RIPPLE}$ $V_{RIPPLE} = 0.1\text{V}$, Freq. = 1kHz $I_{OUT} = 10\text{mA}$ | | 40 | | dB |
| | | $V_{IN} = V_{OUTNOM} + 1\text{V} \pm V_{RIPPLE}$ $V_{RIPPLE} = 0.1\text{V}$, Freq.=10kHz $I_{OUT} = 1\text{mA}$ | | 30 | | |
| | | $V_{IN} = V_{OUTNOM} + 1\text{V} \pm V_{RIPPLE}$ $V_{RIPPLE} = 0.1\text{V}$, Freq.=100kHz $I_{OUT} = 1\text{mA}$ | | 15 | | |
| I_Q | Quiescent current | $I_{OUT} = 0$ | | 1.0 | 1.7 | μA |
| | | $I_{OUT} = 0$ to 150mA , $-40^\circ\text{C} < T_J < 125^\circ\text{C}$ | | 1.7 | 2.4 | |
| I_{OFF} | Shutdown current ⁽²⁾ | V_{IN} input current in OFF mode: $V_{EN} = \text{GND}$, $-40^\circ\text{C} < T_J < 125^\circ\text{C}$ | | 1 | 200 | nA |
| I_{SC} | Short circuit current | $R_L = 0$ | 250 | 350 | | mA |
| V_{EN} | Enable input logic low | $V_{IN} = 1.5\text{V}$ to 5.5V | | | 0.4 | V |
| | Enable input logic high | $V_{IN} = 1.5\text{V}$ to 5.5V | 0.7 | | | V |
| I_{EN} | Enable pin input current | $V_{EN} = 5.5\text{V}$ | | 1 | 200 | nA |
| T_{ON} | Turn-on time ⁽³⁾ | $V_{OUT} = 0.8\text{V}$, $I_{OUT} = 150\text{mA}$ | | 160 | | μs |
| T_{SHDN} | Thermal shutdown | | | 170 | | $^\circ\text{C}$ |
| | Hysteresis | | | 180 | | |

Table 5. Electrical characteristics (continued)

| Symbol | Parameter | Test conditions | Min. | Typ. | Max. | Unit |
|------------------|------------------|---|-------|------|------|------|
| C _{OUT} | Output capacitor | Capacitance (see typical performance characteristics for stability) | 0.47 | | 10 | μF |
| | ESR | | 0.056 | | 6 | Ω |

1. Dropout voltage is the input-to-output voltage difference at which the output voltage is 100 mV below its nominal value. This specification does not apply for output voltages below 1.5 V
2. During shutdown and at no load, P-channel leakage current flowing through the internal resistor divider determines the increase of V_{OUT}
3. Turn-on time is the time measured between the enable input just exceeding V_{EN} high value and the output voltage just reaching 95% of its nominal value

6 Typical performance characteristics

Figure 4. Output voltage vs. temperature

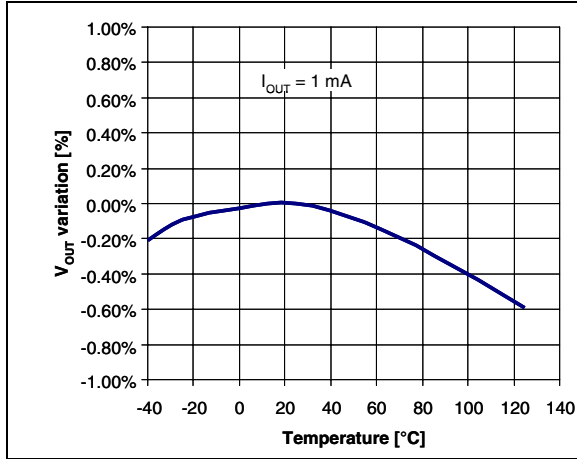

Figure 5. Output voltage vs. input voltage

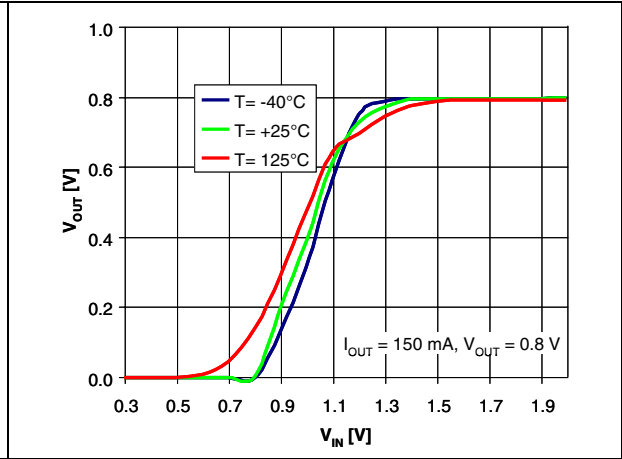

Figure 6. Output voltage vs. input voltage

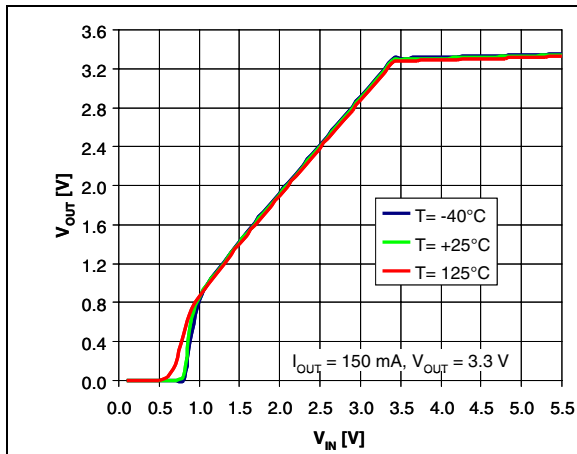

Figure 7. Dropout voltage vs. temperature

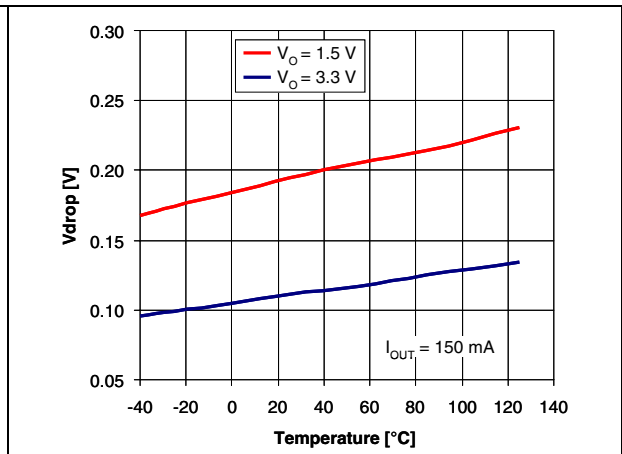

Figure 8. Dropout voltage vs. output current

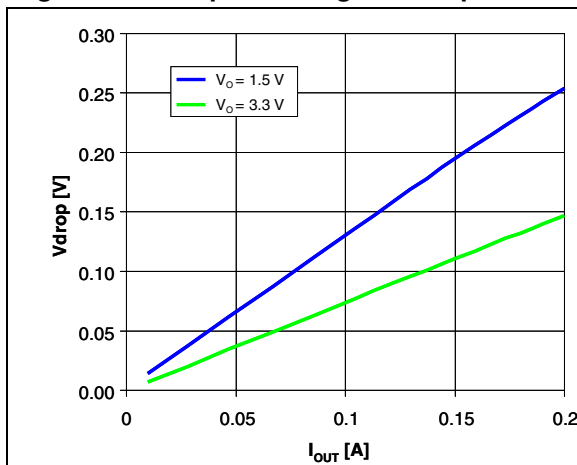

Figure 9. Quiescent current vs. temperature

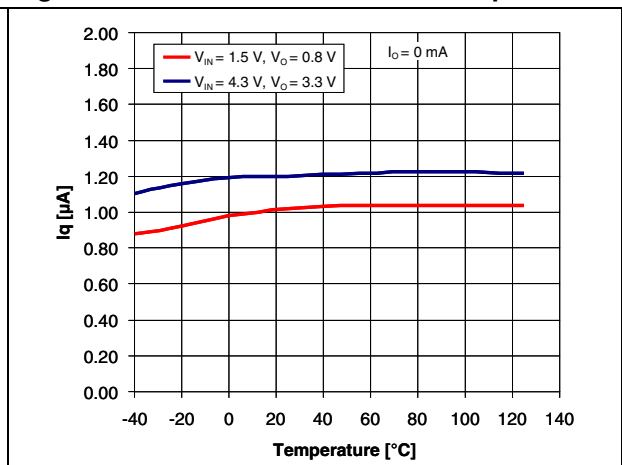

Figure 10. Supply voltage rejection vs. frequency

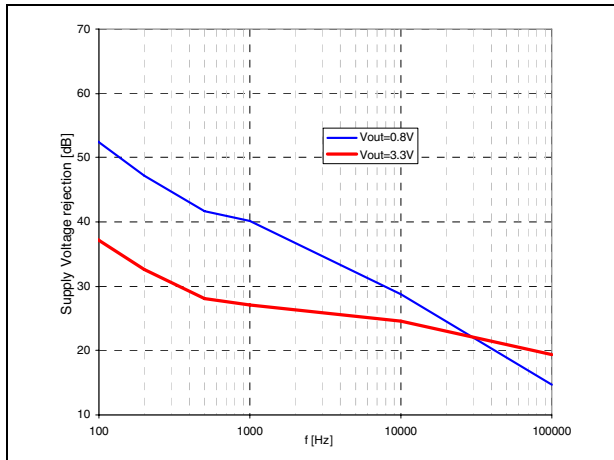

Figure 11. Supply voltage rejection vs. I_{OUT}

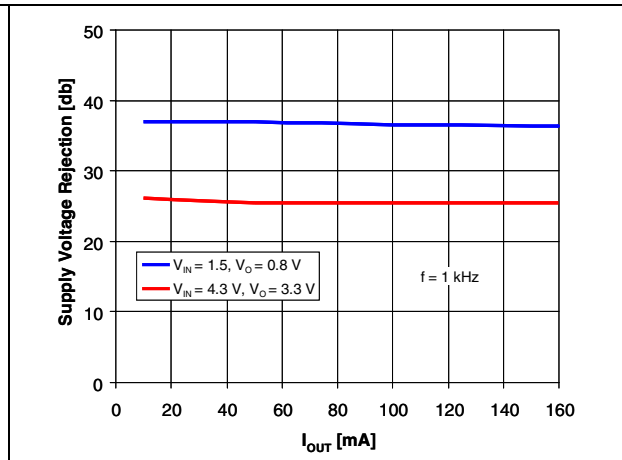

Figure 12. Quiescent current vs. input voltage Figure 13. Quiescent current vs. output current

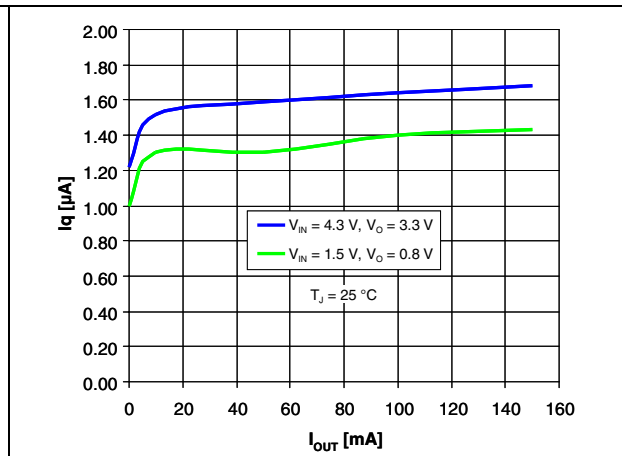
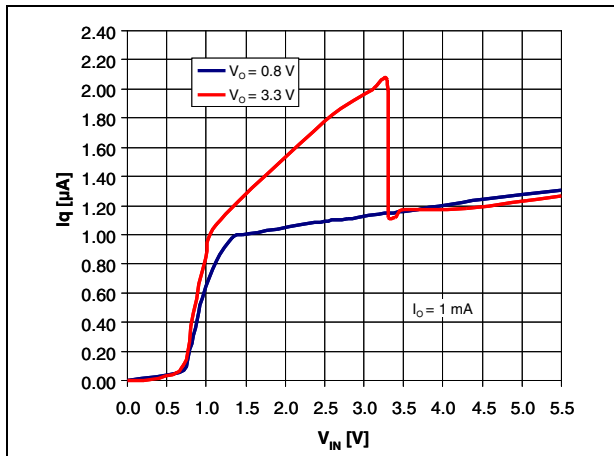

Figure 14. Output noise voltage vs. frequency Figure 15. C_{OUT} stability region

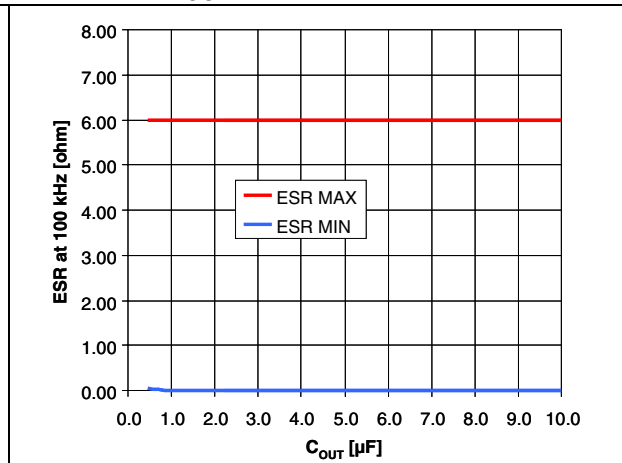
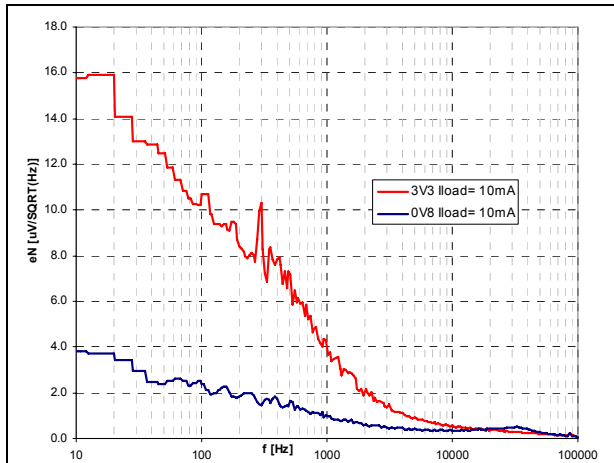
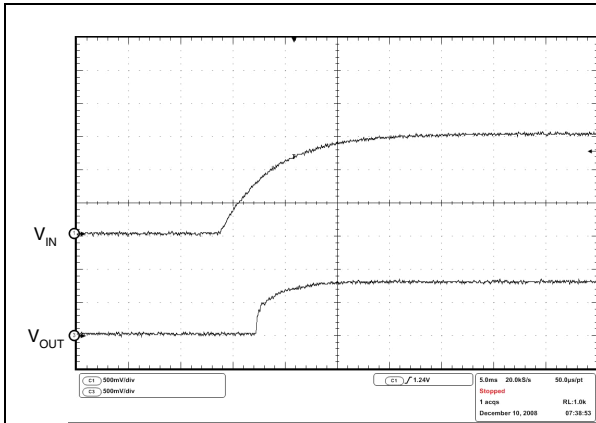
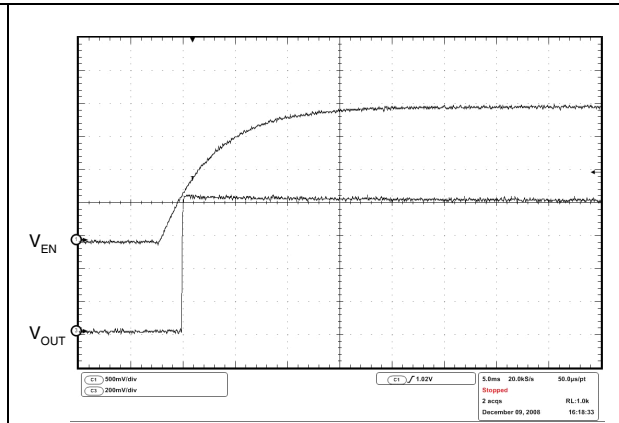

Figure 16. Startup transient



V_{IN} from 0 to 1.5 V, V_{EN} tied to V_{IN} , No Load $C_{OUT} = 1 \mu\text{F}$

Figure 17. Enable transient



$V_{IN} = 1.5 \text{ V}$; V_{EN} from 0 to 2 V, No Load, $T = 25 \text{ }^\circ\text{C}$

7 Package mechanical data

In order to meet environmental requirements, ST offers these devices in different grades of ECOPACK[®] packages, depending on their level of environmental compliance. ECOPACK[®] specifications, grade definitions and product status are available at: www.st.com. ECOPACK[®] is an ST trademark.

Table 6. SOT666 mechanical data

| Dim. | mm. | | | inch. | | |
|------|------|------|------|-------|-------|-------|
| | Min. | Typ. | Max. | Min. | Typ. | Max. |
| A | 0.45 | | 0.60 | 0.018 | | 0.024 |
| A3 | 0.08 | | 0.18 | 0.005 | | 0.007 |
| b | 0.17 | | 0.34 | 0.007 | | 0.013 |
| b1 | 0.19 | 0.27 | 0.34 | 0.007 | 0.011 | 0.013 |
| D | 1.50 | | 1.70 | 0.059 | | 0.067 |
| E | 1.50 | | 1.70 | 0.059 | | 0.067 |
| E1 | 1.10 | | 1.30 | 0.043 | | 0.051 |
| e | | 0.50 | | | 0.020 | |
| L1 | | 0.19 | | | 0.007 | |
| L2 | 0.10 | | 0.30 | 0.004 | | 0.012 |
| L3 | | 0.10 | | | 0.004 | |

Figure 18. Drawing dimension SOT666

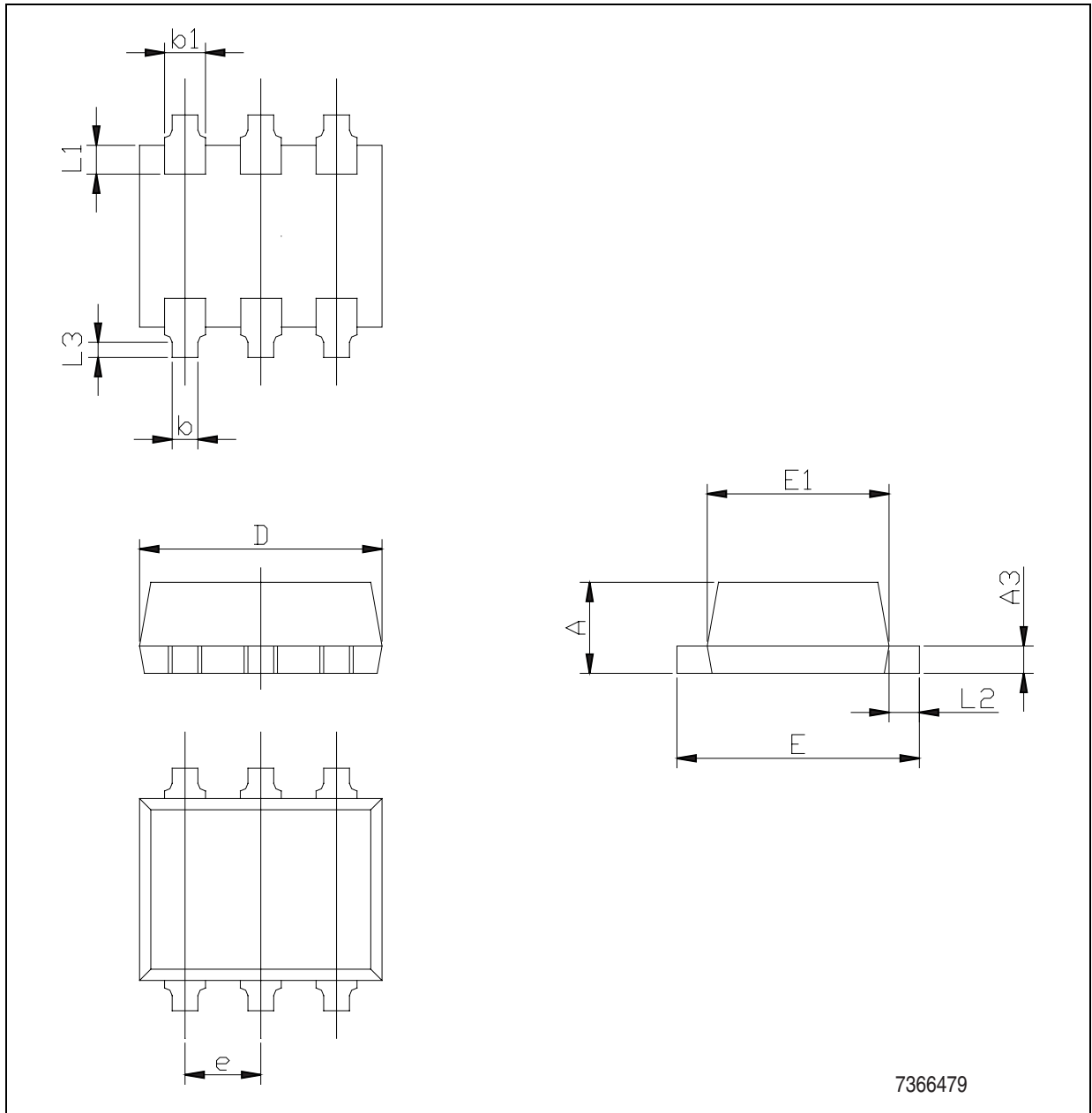
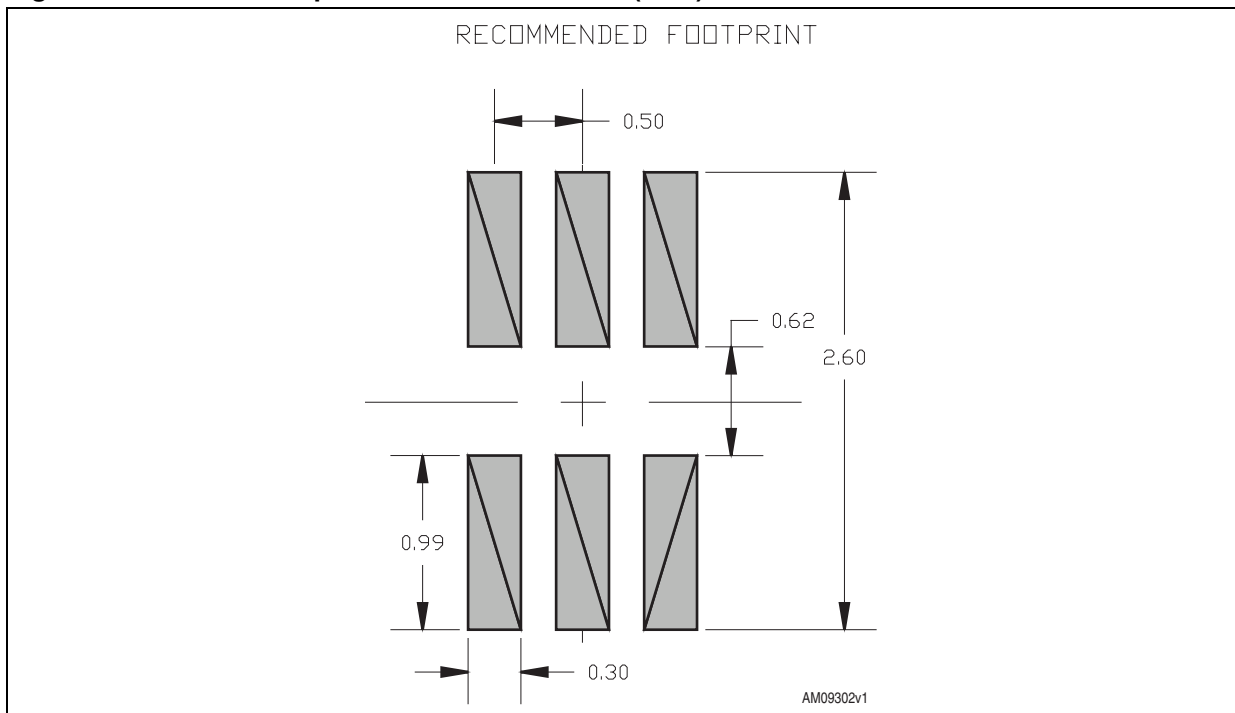

Figure 19. SOT666 footprint recommended data (mm.)



8 Different output voltage versions of the STLQ015xx available on request

Table 7. Options available on request

| Order codes | Output voltages |
|--------------|-----------------|
| STLQ015XG12R | 1.2 V |
| STLQ015XG18R | 1.8 V |

9 Revision history

Table 8. Document revision history

| Date | Revision | Changes |
|-------------|----------|---|
| 23-Mar-2010 | 1 | Initial release. |
| 20-Jan-2011 | 2 | Modified <i>Table 6 on page 12</i> and <i>Figure 18 on page 13</i> . Added <i>Figure 19 on page 14</i> . |

Please Read Carefully:

Information in this document is provided solely in connection with ST products. STMicroelectronics NV and its subsidiaries ("ST") reserve the right to make changes, corrections, modifications or improvements, to this document, and the products and services described herein at any time, without notice.

All ST products are sold pursuant to ST's terms and conditions of sale.

Purchasers are solely responsible for the choice, selection and use of the ST products and services described herein, and ST assumes no liability whatsoever relating to the choice, selection or use of the ST products and services described herein.

No license, express or implied, by estoppel or otherwise, to any intellectual property rights is granted under this document. If any part of this document refers to any third party products or services it shall not be deemed a license grant by ST for the use of such third party products or services, or any intellectual property contained therein or considered as a warranty covering the use in any manner whatsoever of such third party products or services or any intellectual property contained therein.

UNLESS OTHERWISE SET FORTH IN ST'S TERMS AND CONDITIONS OF SALE ST DISCLAIMS ANY EXPRESS OR IMPLIED WARRANTY WITH RESPECT TO THE USE AND/OR SALE OF ST PRODUCTS INCLUDING WITHOUT LIMITATION IMPLIED WARRANTIES OF MERCHANTABILITY, FITNESS FOR A PARTICULAR PURPOSE (AND THEIR EQUIVALENTS UNDER THE LAWS OF ANY JURISDICTION), OR INFRINGEMENT OF ANY PATENT, COPYRIGHT OR OTHER INTELLECTUAL PROPERTY RIGHT.

UNLESS EXPRESSLY APPROVED IN WRITING BY AN AUTHORIZED ST REPRESENTATIVE, ST PRODUCTS ARE NOT RECOMMENDED, AUTHORIZED OR WARRANTED FOR USE IN MILITARY, AIR CRAFT, SPACE, LIFE SAVING, OR LIFE SUSTAINING APPLICATIONS, NOR IN PRODUCTS OR SYSTEMS WHERE FAILURE OR MALFUNCTION MAY RESULT IN PERSONAL INJURY, DEATH, OR SEVERE PROPERTY OR ENVIRONMENTAL DAMAGE. ST PRODUCTS WHICH ARE NOT SPECIFIED AS "AUTOMOTIVE GRADE" MAY ONLY BE USED IN AUTOMOTIVE APPLICATIONS AT USER'S OWN RISK.

Resale of ST products with provisions different from the statements and/or technical features set forth in this document shall immediately void any warranty granted by ST for the ST product or service described herein and shall not create or extend in any manner whatsoever, any liability of ST.

ST and the ST logo are trademarks or registered trademarks of ST in various countries.

Information in this document supersedes and replaces all information previously supplied.

The ST logo is a registered trademark of STMicroelectronics. All other names are the property of their respective owners.

© 2011 STMicroelectronics - All rights reserved

STMicroelectronics group of companies

Australia - Belgium - Brazil - Canada - China - Czech Republic - Finland - France - Germany - Hong Kong - India - Israel - Italy - Japan - Malaysia - Malta - Morocco - Philippines - Singapore - Spain - Sweden - Switzerland - United Kingdom - United States of America

www.st.com