

Ultra-low-power 32b MCU ARM<sup>®</sup>-based Cortex<sup>®</sup>-M3, 384KB Flash, 48KB SRAM, 12KB EEPROM, LCD, USB, ADC, memory I/F, AES

Datasheet - production data

## FeaturesFeatures

- Ultra-low-power platform
  - 1.65 V to 3.6 V power supply
  - **-40°C to 105°C** temperature range
  - 305 nA standby mode (3 wakeup pins)
  - **1.15 µA standby mode + RTC**
  - 0.475 µA stop mode (16 wakeup lines)
  - 1.35 µA stop mode + RTC
  - 11 µA low-power run mode
  - 230 µA/MHz run mode
  - 10 nA ultra-low I/O leakage
  - 8 µs wakeup time
- AES-128 bit encryption hardware accelerator
- Core: ARM<sup>®</sup> Cortex<sup>®</sup>-M3 32-bit CPU
  - From 32 kHz up to 32 MHz max
  - 1.25 DMIPS/MHz (Dhrystone 2.1)
  - Memory protection unit
- Reset and supply management
  - Low power, ultrasafe BOR (brownout reset) with 5 selectable thresholds
  - Ultra-low-power POR/PDR
  - Programmable voltage detector (PVD)
- Clock sources
  - 1 to 24 MHz crystal oscillator
  - 32 kHz oscillator for RTC with calibration
  - High Speed Internal 16 MHz factory-trimmed RC (+/- 1%)
  - Internal low power 37 kHz RC
  - Internal multispeed low power 65 kHz to 4.2 MHz
  - PLL for CPU clock and USB (48 MHz)
- Pre-programmed bootloader
  - USB and USART supported
- Development support
  - Serial wire debug supported
  - JTAG and trace supported
- Up to 116 fast I/Os (102 I/Os 5V tolerant), all mappable on 16 external interrupt vectors

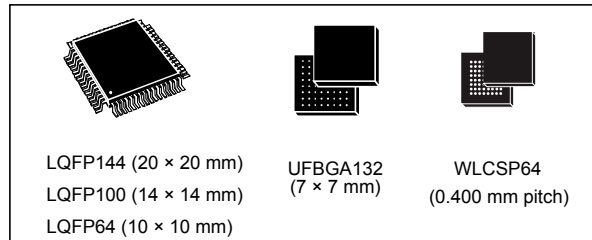

- Memories
  - 384 KB Flash with ECC (with 2 bank of 192 KB enabling Rww capability)
  - 48 KB RAM
  - 12 KB of true EEPROM with ECC
  - 128 Byte Backup Register
  - Memory interface controller supporting SRAM, PSRAM and NOR Flash
- LCD driver for up to 8x40 segments
  - Support contrast adjustment
  - Support blinking mode
  - Step-up converter on board
- Rich analog peripherals (down to 1.8V)
  - 3x Operational Amplifier
  - 12-bit ADC 1 Msps up to 40 channels
  - 12-bit DAC 2 ch with output buffers
  - 2x ultra-low-power-comparators (window mode and wake up capability)
- DMA controller 12x channels
- 12x peripherals communication interface
  - 1x USB 2.0 (internal 48 MHz PLL)
  - 5x USART
  - 3x SPI 16Mbits/s (2x SPI with I2S)
  - 2x I2C (SMBus/PMBus)
  - 1x SDIO interface
- 11x timers: 1x 32-bit, 6x 16-bit with up to 4 IC/OC/PWM channels, 2x 16-bit basic timer, 2x watchdog timers (independent and window)
- Up to 34 capacitive sensing channels
- CRC calculation unit, 96-bit unique ID

# Contents

<b>1</b>	<b>Introduction</b>	<b>10</b>
<b>2</b>	<b>Description</b>	<b>11</b>
2.1	Device overview	12
2.2	Ultra-low-power device continuum	13
2.2.1	Performance	13
2.2.2	Shared peripherals	13
2.2.3	Common system strategy	14
2.2.4	Features	14
<b>3</b>	<b>Functional overview</b>	<b>15</b>
3.1	Low-power modes	16
3.2	ARM Cortex-M3 core with MPU	20
3.3	Reset and supply management	21
3.3.1	Power supply schemes	21
3.3.2	Power supply supervisor	21
3.3.3	Voltage regulator	22
3.3.4	Boot modes	22
3.4	Clock management	23
3.5	Low-power real-time clock and backup registers	25
3.6	GPIOs (general-purpose inputs/outputs)	25
3.7	Memories	26
3.8	FSMC (flexible static memory controller)	26
3.9	DMA (direct memory access)	26
3.10	LCD (liquid crystal display)	27
3.11	ADC (analog-to-digital converter)	27
3.11.1	Temperature sensor	27
3.11.2	Internal voltage reference ( $V_{REFINT}$ )	28
3.12	DAC (digital-to-analog converter)	28
3.13	Operational amplifier	28
3.14	Ultra-low-power comparators and reference voltage	29
3.15	System configuration controller and routing interface	29

3.16	Touch sensing	29
3.17	AES	29
3.18	Timers and watchdogs	30
3.18.1	General-purpose timers (TIM2, TIM3, TIM4, TIM5, TIM9, TIM10 and TIM11)	30
3.18.2	Basic timers (TIM6 and TIM7)	31
3.18.3	SysTick timer	31
3.18.4	Independent watchdog (IWDG)	31
3.18.5	Window watchdog (WWDG)	31
3.19	Communication interfaces	31
3.19.1	I <sup>2</sup> C bus	31
3.19.2	Universal synchronous/asynchronous receiver transmitter (USART)	32
3.19.3	Serial peripheral interface (SPI)	32
3.19.4	Inter-integrated sound (I2S)	32
3.19.5	SDIO	32
3.19.6	Universal serial bus (USB)	32
3.20	CRC (cyclic redundancy check) calculation unit	33
3.21	Development support	33
3.21.1	Serial wire JTAG debug port (SWJ-DP)	33
3.21.2	Embedded Trace Macrocell™	33
<b>4</b>	<b>Pin descriptions</b>	<b>34</b>
<b>5</b>	<b>Memory mapping</b>	<b>58</b>
<b>6</b>	<b>Electrical characteristics</b>	<b>59</b>
6.1	Parameter conditions	59
6.1.1	Minimum and maximum values	59
6.1.2	Typical values	59
6.1.3	Typical curves	59
6.1.4	Loading capacitor	59
6.1.5	Pin input voltage	59
6.1.6	Power supply scheme	60
6.1.7	Optional LCD power supply scheme	61
6.1.8	Current consumption measurement	61
6.2	Absolute maximum ratings	62
6.3	Operating conditions	63

6.3.1	General operating conditions	63
6.3.2	Embedded reset and power control block characteristics	64
6.3.3	Embedded internal reference voltage	66
6.3.4	Supply current characteristics	67
6.3.5	Wakeup time from low-power mode	78
6.3.6	External clock source characteristics	79
6.3.7	Internal clock source characteristics	85
6.3.8	PLL characteristics	88
6.3.9	Memory characteristics	88
6.3.10	FSMC characteristics	90
6.3.11	EMC characteristics	102
6.3.12	Electrical sensitivity characteristics	103
6.3.13	I/O current injection characteristics	104
6.3.14	I/O port characteristics	105
6.3.15	NRST pin characteristics	108
6.3.16	TIM timer characteristics	109
6.3.17	Communications interfaces	110
6.3.18	SDIO characteristics	118
6.3.19	12-bit ADC characteristics	119
6.3.20	DAC electrical specifications	124
6.3.21	Operational amplifier characteristics	126
6.3.22	Temperature sensor characteristics	128
6.3.23	Comparator	128
6.3.24	LCD controller	130
<b>7</b>	<b>Package characteristics</b>	<b>131</b>
7.1	Package mechanical data	131
7.1.1	LQFP144, 20 x 20 mm, 144-pin low-profile quad flat package	131
7.1.2	LQFP100, 14 x 14 mm, 100-pin low-profile quad flat package	134
7.1.3	LQFP64, 10 x 10 mm, 64-pin low-profile quad flat package	137
7.1.4	UFPGA132, 7 x 7 mm, 132-ball ultra thin, fine-pitch ball grid array package	140
7.1.5	WLCSP64, 0.400 mm pitch wafer level chip size package	143
7.2	Thermal characteristics	145
7.2.1	Reference document	146
<b>8</b>	<b>Part numbering</b>	<b>147</b>

---

<b>9</b>	<b>Revision History .....</b>	<b>148</b>
----------	-------------------------------	------------

## List of tables

Table 1.	Ultra-low-power STM32L162xD device features and peripheral counts . . . . .	12
Table 2.	Functionalities depending on the operating power supply range . . . . .	17
Table 3.	CPU frequency range depending on dynamic voltage scaling . . . . .	18
Table 4.	Functionalities depending on the working mode (from Run/active down to standby) . . . . .	19
Table 5.	Timer feature comparison . . . . .	30
Table 6.	Legend/abbreviations used in the pinout table . . . . .	39
Table 7.	STM32L162xD pin definitions . . . . .	40
Table 8.	Alternate function input/output . . . . .	50
Table 9.	Voltage characteristics . . . . .	62
Table 10.	Current characteristics . . . . .	62
Table 11.	Thermal characteristics . . . . .	63
Table 12.	General operating conditions . . . . .	63
Table 13.	Embedded reset and power control block characteristics . . . . .	64
Table 14.	Embedded internal reference voltage calibration values . . . . .	66
Table 15.	Embedded internal reference voltage . . . . .	66
Table 16.	Current consumption in Run mode, code with data processing running from Flash . . . . .	68
Table 17.	Current consumption in Run mode, code with data processing running from RAM . . . . .	69
Table 18.	Current consumption in Sleep mode . . . . .	70
Table 19.	Current consumption in Low-power run mode . . . . .	71
Table 20.	Current consumption in Low-power sleep mode . . . . .	72
Table 21.	Typical and maximum current consumptions in Stop mode . . . . .	73
Table 22.	Typical and maximum current consumptions in Standby mode . . . . .	75
Table 23.	Peripheral current consumption . . . . .	76
Table 24.	Low-power mode wakeup timings . . . . .	79
Table 25.	High-speed external user clock characteristics . . . . .	79
Table 26.	Low-speed external user clock characteristics . . . . .	81
Table 27.	HSE oscillator characteristics . . . . .	82
Table 28.	LSE oscillator characteristics ( $f_{LSE} = 32.768$ kHz) . . . . .	83
Table 29.	HSI oscillator characteristics . . . . .	85
Table 30.	LSI oscillator characteristics . . . . .	85
Table 31.	MSI oscillator characteristics . . . . .	86
Table 32.	PLL characteristics . . . . .	88
Table 33.	RAM and hardware registers . . . . .	88
Table 34.	Flash memory and data EEPROM characteristics . . . . .	89
Table 35.	Flash memory and data EEPROM endurance and retention . . . . .	89
Table 36.	Asynchronous non-multiplexed SRAM/PSRAM/NOR read timings . . . . .	91
Table 37.	Asynchronous non-multiplexed SRAM/PSRAM/NOR write timings . . . . .	92
Table 38.	Asynchronous multiplexed PSRAM/NOR read timings . . . . .	93
Table 39.	Asynchronous multiplexed PSRAM/NOR write timings . . . . .	94
Table 40.	Synchronous multiplexed NOR/PSRAM read timings . . . . .	96
Table 41.	Synchronous multiplexed PSRAM write timings . . . . .	98
Table 42.	Synchronous non-multiplexed NOR/PSRAM read timings . . . . .	99
Table 43.	Synchronous non-multiplexed PSRAM write timings . . . . .	100
Table 44.	EMS characteristics . . . . .	102
Table 45.	EMI characteristics . . . . .	103
Table 46.	ESD absolute maximum ratings . . . . .	103
Table 47.	Electrical sensitivities . . . . .	104

Table 48.	I/O current injection susceptibility . . . . .	104
Table 49.	I/O static characteristics . . . . .	105
Table 50.	Output voltage characteristics. . . . .	106
Table 51.	I/O AC characteristics . . . . .	107
Table 52.	NRST pin characteristics . . . . .	108
Table 53.	TIMx characteristics . . . . .	109
Table 54.	I <sup>2</sup> C characteristics . . . . .	110
Table 55.	SCL frequency ( $f_{PCLK1} = 32$ MHz, $V_{DD} = V_{DD\_I2C} = 3.3$ V). . . . .	111
Table 56.	SPI characteristics . . . . .	112
Table 57.	USB startup time. . . . .	115
Table 58.	USB DC electrical characteristics . . . . .	115
Table 59.	USB: full speed electrical characteristics . . . . .	115
Table 60.	I2S characteristics. . . . .	116
Table 61.	SDIO characteristics . . . . .	118
Table 62.	ADC clock frequency . . . . .	119
Table 63.	ADC characteristics . . . . .	119
Table 64.	ADC accuracy . . . . .	121
Table 65.	Maximum source impedance $R_{AIN}$ max . . . . .	123
Table 66.	DAC characteristics . . . . .	124
Table 67.	Operational amplifier characteristics. . . . .	126
Table 68.	Temperature sensor calibration values. . . . .	128
Table 69.	Temperature sensor characteristics . . . . .	128
Table 70.	Comparator 1 characteristics . . . . .	128
Table 71.	Comparator 2 characteristics . . . . .	129
Table 72.	LCD controller characteristics. . . . .	130
Table 73.	LQFP144, 20 x 20 mm, 144-pin low-profile quad flat package mechanical data . . . . .	132
Table 74.	LQPF100, 14 x 14 mm, 100-pin low-profile quad flat package mechanical data . . . . .	135
Table 75.	LQFP64, 10 x 10 mm 64-pin low-profile quad flat package mechanical data. . . . .	138
Table 76.	UFPGA132, 7 x 7 mm, 132-ball ultra thin, fine-pitch ball grid array mechanical data . . . . .	140
Table 77.	WLCSP64, 0.400 mm pitch wafer level chip size package mechanical data . . . . .	144
Table 78.	Thermal characteristics. . . . .	145
Table 79.	STM32L162xD ordering information scheme . . . . .	147
Table 80.	Document revision history. . . . .	148

## List of figures

Figure 1.	Ultra-low-power STM32L162xD block diagram	15
Figure 2.	Clock tree	24
Figure 3.	STM32L162ZD LQFP144 pinout	34
Figure 4.	STM32L162QD UFBGA132 ballout	35
Figure 5.	STM32L162VD LQFP100 pinout	36
Figure 6.	STM32L162RD LQFP64 pinout	37
Figure 7.	STM32L162RD WLCSP64 ballout	38
Figure 8.	Memory map	58
Figure 9.	Pin loading conditions	59
Figure 10.	Pin input voltage	59
Figure 11.	Power supply scheme	60
Figure 12.	Optional LCD power supply scheme	61
Figure 13.	Current consumption measurement scheme	61
Figure 14.	High-speed external clock source AC timing diagram	80
Figure 15.	Low-speed external clock source AC timing diagram	81
Figure 16.	HSE oscillator circuit diagram	83
Figure 17.	Typical application with a 32.768 kHz crystal	84
Figure 18.	Asynchronous non-multiplexed SRAM/PSRAM/NOR read waveforms	90
Figure 19.	Asynchronous non-multiplexed SRAM/PSRAM/NOR write waveforms	91
Figure 20.	Asynchronous multiplexed PSRAM/NOR read waveforms	92
Figure 21.	Asynchronous multiplexed PSRAM/NOR write waveforms	93
Figure 22.	Synchronous multiplexed NOR/PSRAM read timings	95
Figure 23.	Synchronous multiplexed PSRAM write timings	97
Figure 24.	Synchronous non-multiplexed NOR/PSRAM read timings	99
Figure 25.	Synchronous non-multiplexed PSRAM write timings	100
Figure 26.	I/O AC characteristics definition	108
Figure 27.	Recommended NRST pin protection	109
Figure 28.	I <sup>2</sup> C bus AC waveforms and measurement circuit	111
Figure 29.	SPI timing diagram - slave mode and CPHA = 0	113
Figure 30.	SPI timing diagram - slave mode and CPHA = 1 <sup>(1)</sup>	113
Figure 31.	SPI timing diagram - master mode <sup>(1)</sup>	114
Figure 32.	USB timings: definition of data signal rise and fall time	115
Figure 33.	I <sup>2</sup> S slave timing diagram (Philips protocol) <sup>(1)</sup>	117
Figure 34.	I <sup>2</sup> S master timing diagram (Philips protocol) <sup>(1)</sup>	117
Figure 35.	SDIO timings	118
Figure 36.	ADC accuracy characteristics	122
Figure 37.	Typical connection diagram using the ADC	122
Figure 38.	Maximum dynamic current consumption on V <sub>REF+</sub> supply pin during ADC conversion	123
Figure 39.	12-bit buffered /non-buffered DAC	126
Figure 40.	LQFP144, 20 x 20 mm, 144-pin low-profile quad flat package outline	131
Figure 41.	LQFP144 recommended footprint	132
Figure 42.	LQFP144 package top view	133
Figure 43.	LQFP100, 14 x 14 mm, 100-pin low-profile quad flat package outline	134
Figure 44.	LQFP100 recommended footprint	135
Figure 45.	LQFP100 package top view	136
Figure 46.	LQFP64, 10 x 10 mm, 64-pin low-profile quad flat package outline	137
Figure 47.	LQFP64 recommended footprint	138

---

Figure 48.	LQFP64 package top view . . . . .	139
Figure 49.	UFBGA132, 7 x 7 mm, 132-ball ultra thin, fine-pitch ball grid array package outline . . . . .	140
Figure 50.	UFBGA132 recommended footprint . . . . .	141
Figure 51.	UFBGA132 package top view. . . . .	141
Figure 52.	WLCSP64, 0.400 mm pitch wafer level chip size package outline . . . . .	143
Figure 53.	WLCSP64 package top view . . . . .	144
Figure 54.	Thermal resistance suffix 6. . . . .	146
Figure 55.	Thermal resistance suffix 7. . . . .	146

# 1 Introduction

This datasheet provides the ordering information and mechanical device characteristics of the STM32L162xD ultra-low-power ARM® Cortex®-M3 based microcontroller product line. STM32L162xD devices are microcontrollers with a Flash memory density of 384 Kbytes.

The ultra-low-power STM32L162xD family includes devices in different package types: from 64 pins to 144 pins. Depending on the device chosen, different sets of peripherals are included; the description below gives an overview of the complete range of peripherals proposed in this family.

These features make the ultra-low-power STM32L162xD microcontroller family suitable for a wide range of applications:

- Medical and handheld equipment
- Application control and user interface
- PC peripherals, gaming, GPS and sport equipment
- Alarm systems, wired and wireless sensors, video intercom
- Utility metering

This STM32L162xD datasheet should be read in conjunction with the STM32L1xxx reference manual (RM0038). The application note “Getting started with STM32L1xxx hardware development” (AN3216) gives a hardware implementation overview. Both documents are available from the STMicroelectronics website [www.st.com](http://www.st.com).

For information on the ARM® Cortex®-M3 core please refer to the ARM® Cortex®-M3 Technical Reference Manual, available from the [www.arm.com](http://www.arm.com) website. *Figure 1* shows the general block diagram of the device family.

## 2 Description

The ultra-low-power STM32L162xD devices incorporate the connectivity power of the universal serial bus (USB) with the high-performance ARM<sup>®</sup> Cortex<sup>®</sup>-M3 32-bit RISC core operating at a frequency of 32 MHz (33.3 DMIPS), a memory protection unit (MPU), high-speed embedded memories (Flash memory up to 384 Kbytes and RAM up to 48 Kbytes), a flexible static memory controller (FSMC) interface (for devices with packages of 100 pins and more) and an extensive range of enhanced I/Os and peripherals connected to two APB buses.

The STM32L162xD devices offer three operational amplifiers, one 12-bit ADC, two DACs, two ultra-low-power comparators, AES, one general-purpose 32-bit timer, six general-purpose 16-bit timers and two basic timers, which can be used as time bases.

Moreover, the STM32L162xD devices contain standard and advanced communication interfaces: up to two I2Cs, three SPIs, two I2S, one SDIO, three USARTs, two UARTs and an USB. The STM32L162xD devices offer up to 34 capacitive sensing channels to simply add touch sensing functionality to any application.

They also include a real-time clock and a set of backup registers that remain powered in standby mode.

Finally, the integrated LCD controller has a built-in LCD voltage generator that allows you to drive up to 8 multiplexed LCDs with contrast independent of the supply voltage.

The ultra-low-power STM32L162xD devices operate from a 1.8 to 3.6 V power supply (down to 1.65 V at power down) with BOR and from a 1.65 to 3.6 V power supply without BOR option. They are available in the -40 to +85 °C and -40 to +105 °C temperature ranges. A comprehensive set of power-saving modes allows the design of low-power applications.



## 2.1 Device overview

Table 1. Ultra-low-power STM32L162xD device features and peripheral counts

Peripheral		STM32L162RD	STM32L162VD	STM32L162QD	STM32L162ZD
Flash (Kbytes)		384			
Data EEPROM (KBytes)		12			
RAM (Kbytes)		48			
AES		1			
FSMC		No	Multiplexed only	Yes	
Timers	32 bit	1			
	General-purpose	6			
	Basic	2			
Communication interfaces	SPI/(I2S)	3/(2)			
	I <sup>2</sup> C	2			
	USART	5			
	USB	1			
	SDIO	1			
GPIOs		51	83	109	115
Operation amplifiers		3			
12-bit synchronized ADC Number of channels		1 21	1 25	1 40	
12-bit DAC Number of channels		2 2			
LCD COM x SEG		1 4x32 or 8x28	1 4x44 or 8x40		
Comparators		2			
Capacitive sensing channels		23	23	33	34
Max. CPU frequency		32 MHz			
Operating voltage		1.8 V to 3.6 V (down to 1.65 V at power-down) with BOR option 1.65 V to 3.6 V without BOR option			

Table 1. Ultra-low-power STM32L162xD device features and peripheral counts (continued)

Peripheral	STM32L162RD	STM32L162VD	STM32L162QD	STM32L162ZD
Operating temperatures	Ambient operating temperature: -40 °C to 85 °C / -40 °C to 105 °C Junction temperature: -40 to + 110 °C			
Packages	LQFP64, WLCSP64	LQFP100	UFBGA132	LQFP144

## 2.2 Ultra-low-power device continuum

The ultra-low-power family offers a large choice of cores and features. From proprietary 8-bit to up to Cortex-M3, including the Cortex-M0+, the STM32Lx series are the best choice to answer your needs, in terms of ultra-low-power features. The STM32 Ultra-low-power series are the best fit, for instance, for gas/water meter, keyboard/mouse or fitness and healthcare, wearable applications. Several built-in features like LCD drivers, dual-bank memory, Low-power run mode, op-amp, AES 128-bit, DAC, USB crystal-less and many others will clearly allow you to build very cost-optimized applications by reducing BOM.

*Note: STMicroelectronics as a reliable and long-term manufacturer ensures as much as possible the pin-to-pin compatibility between any STM8Lx and STM32Lx devices and between any of the STM32Lx and STM32Fx series. Thanks to this unprecedented scalability, your old applications can be upgraded to respond to the latest market features and efficiency demand.*

### 2.2.1 Performance

All families incorporate highly energy-efficient cores with both Harvard architecture and pipelined execution: advanced STM8 core for STM8L families and ARM Cortex-M3 core for STM32L family. In addition specific care for the design architecture has been taken to optimize the mA/DMIPS and mA/MHz ratios.

This allows the ultra-low-power performance to range from 5 up to 33.3 DMIPs.

### 2.2.2 Shared peripherals

STM8L15xxx, STM32L15xxx and STM32L162xx share identical peripherals which ensure a very easy migration from one family to another:

- Analog peripherals: ADC, DAC and comparators
- Digital peripherals: RTC and some communication interfaces

### 2.2.3 Common system strategy.

To offer flexibility and optimize performance, the STM8L15xxx, STM32L15xxx and STM32L162xx family uses a common architecture:

- Same power supply range from 1.65 V to 3.6 V
- Architecture optimized to reach ultra-low consumption both in low-power modes and Run mode
- Fast startup strategy from low-power modes
- Flexible system clock
- Ultrasafe reset: same reset strategy including power-on reset, power-down reset, brownout reset and programmable voltage detector

### 2.2.4 Features

ST ultra-low-power continuum also lies in feature compatibility:

- More than 15 packages with pin count from 20 to 144 pins and size down to 3 x 3 mm
- Memory density ranging from 2 to 512 Kbytes

### 3 Functional overview

Figure 1. Ultra-low-power STM32L162xD block diagram

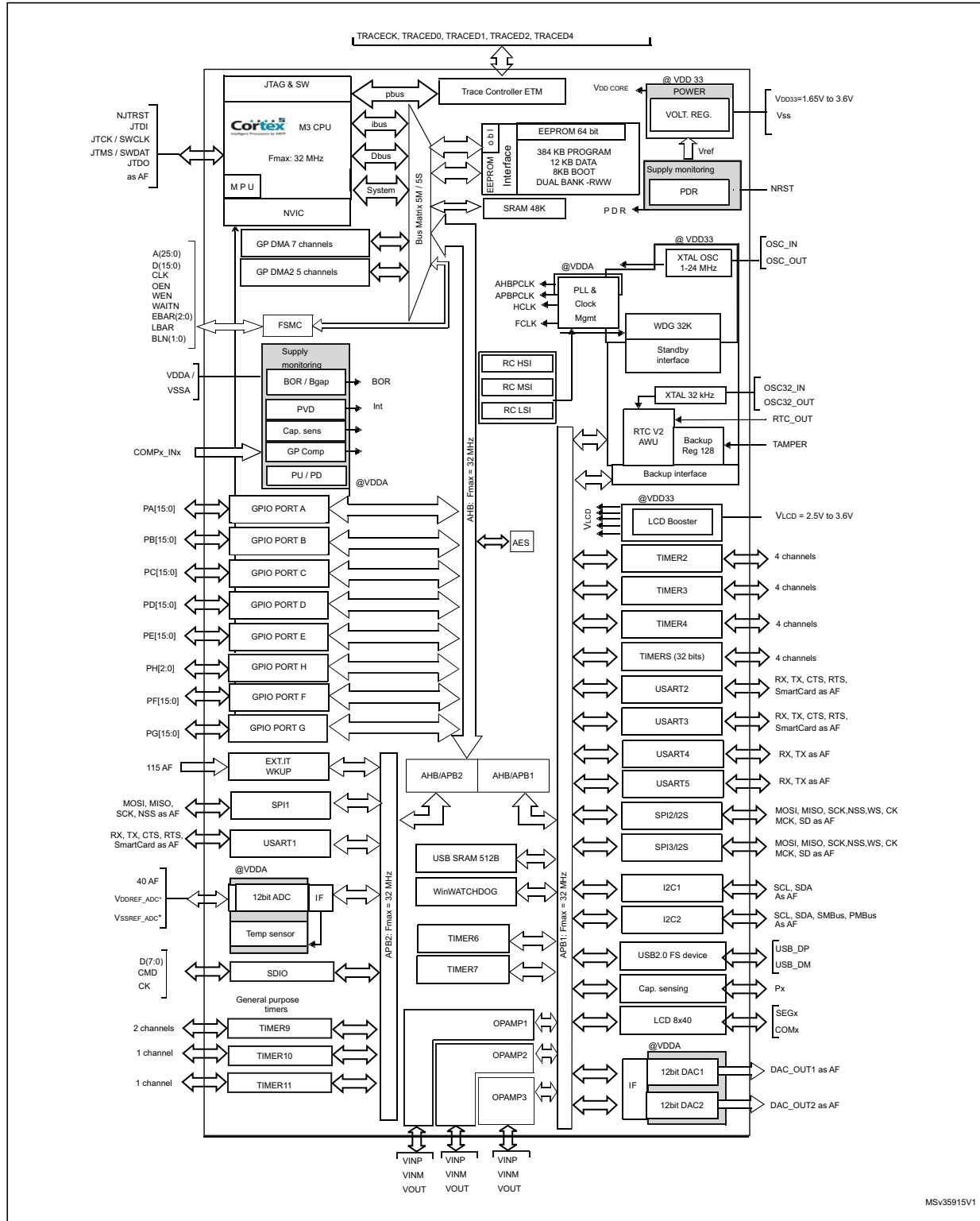

MSv35915V1



## 3.1 Low-power modes

The ultra-low-power STM32L162xD supports dynamic voltage scaling to optimize its power consumption in run mode. The voltage from the internal low-drop regulator that supplies the logic can be adjusted according to the system's maximum operating frequency and the external voltage supply.

There are three power consumption ranges:

- Range 1 ( $V_{DD}$  range limited to 1.71 V - 3.6 V), with the CPU running at up to 32 MHz
- Range 2 (full  $V_{DD}$  range), with a maximum CPU frequency of 16 MHz
- Range 3 (full  $V_{DD}$  range), with a maximum CPU frequency limited to 4 MHz (generated only with the multispeed internal RC oscillator clock source)

Seven low-power modes are provided to achieve the best compromise between low-power consumption, short startup time and available wakeup sources:

- **Sleep mode**

In Sleep mode, only the CPU is stopped. All peripherals continue to operate and can wake up the CPU when an interrupt/event occurs. Sleep mode power consumption at 16 MHz is about 1 mA with all peripherals off.
- **Low-power run mode**

This mode is achieved with the multispeed internal (MSI) RC oscillator set to the minimum clock (131 kHz), execution from SRAM or Flash memory, and internal regulator in low-power mode to minimize the regulator's operating current. In Low-power run mode, the clock frequency and the number of enabled peripherals are both limited.
- **Low-power sleep mode**

This mode is achieved by entering Sleep mode with the internal voltage regulator in Low power mode to minimize the regulator's operating current. In Low power sleep mode, both the clock frequency and the number of enabled peripherals are limited; a typical example would be to have a timer running at 32 kHz.

When wakeup is triggered by an event or an interrupt, the system reverts to the run mode with the regulator on.
- **Stop mode with RTC**

Stop mode achieves the lowest power consumption while retaining the RAM and register contents and real time clock. All clocks in the  $V_{CORE}$  domain are stopped, the PLL, MSI RC, HSI RC and HSE crystal oscillators are disabled. The LSE or LSI is still running. The voltage regulator is in the low-power mode.

The device can be woken up from Stop mode by any of the EXTI line, in 8  $\mu$ s. The EXTI line source can be one of the 16 external lines. It can be the PVD output, the Comparator 1 event or Comparator 2 event (if internal reference voltage is on), it can be the RTC alarm(s), the USB wakeup, the RTC tamper events, the RTC timestamp event or the RTC wakeup.

- Stop mode without RTC**

Stop mode achieves the lowest power consumption while retaining the RAM and register contents. All clocks are stopped, the PLL, MSI RC, HSI and LSI RC, LSE and HSE crystal oscillators are disabled. The voltage regulator is in the low-power mode. The device can be woken up from Stop mode by any of the EXTI line, in 8  $\mu$ s. The EXTI line source can be one of the 16 external lines. It can be the PVD output, the Comparator 1 event or Comparator 2 event (if internal reference voltage is on). It can also be wakened by the USB wakeup.
- Standby mode with RTC**

Standby mode is used to achieve the lowest power consumption and real time clock. The internal voltage regulator is switched off so that the entire  $V_{CORE}$  domain is powered off. The PLL, MSI RC, HSI RC and HSE crystal oscillators are also switched off. The LSE or LSI is still running. After entering Standby mode, the RAM and register contents are lost except for registers in the Standby circuitry (wakeup logic, IWDG, RTC, LSI, LSE Crystal 32K osc, RCC\_CSR).

The device exits Standby mode in 60  $\mu$ s when an external reset (NRST pin), an IWDG reset, a rising edge on one of the three WKUP pins, RTC alarm (Alarm A or Alarm B), RTC tamper event, RTC timestamp event or RTC Wakeup event occurs.
- Standby mode without RTC**

Standby mode is used to achieve the lowest power consumption. The internal voltage regulator is switched off so that the entire  $V_{CORE}$  domain is powered off. The PLL, MSI RC, HSI and LSI RC, HSE and LSE crystal oscillators are also switched off. After entering Standby mode, the RAM and register contents are lost except for registers in the Standby circuitry (wakeup logic, IWDG, RTC, LSI, LSE Crystal 32K osc, RCC\_CSR).

The device exits Standby mode in 60  $\mu$ s when an external reset (NRST pin) or a rising edge on one of the three WKUP pin occurs.

*Note: The RTC, the IWDG, and the corresponding clock sources are not stopped automatically by entering Stop or Standby mode.*

**Table 2. Functionalities depending on the operating power supply range**

Operating power supply range	Functionalities depending on the operating power supply range			
	DAC and ADC operation	USB	Dynamic voltage scaling range	I/O operation
$V_{DD}=V_{DDA}=1.65$ to $1.71$ V	Not functional	Not functional	Range 2 or Range 3	Degraded speed performance
$V_{DD}=V_{DDA}=1.71$ to $1.8$ V <sup>(1)</sup>	Not functional	Not functional	Range 1, Range 2 or Range 3	Degraded speed performance
$V_{DD}=V_{DDA}=1.8$ to $2.0$ V <sup>(1)</sup>	Conversion time up to 500 Ksps	Not functional	Range 1, Range 2 or Range 3	Degraded speed performance

**Table 2. Functionalities depending on the operating power supply range (continued)**

Operating power supply range	Functionalities depending on the operating power supply range			
	DAC and ADC operation	USB	Dynamic voltage scaling range	I/O operation
$V_{DD}=V_{DDA} = 2.0 \text{ to } 2.4 \text{ V}$	Conversion time up to 500 Ksps	Functional <sup>(2)</sup>	Range 1, Range 2 or Range 3	Full speed operation
$V_{DD}=V_{DDA} = 2.4 \text{ to } 3.6 \text{ V}$	Conversion time up to 1 Msp/s	Functional <sup>(2)</sup>	Range 1, Range 2 or Range 3	Full speed operation

1. CPU frequency changes from initial to final must respect " $F_{CPU \text{ initial}} < 4 * F_{CPU \text{ final}}$ " to limit  $V_{CORE}$  drop due to current consumption peak when frequency increases. It must also respect 5  $\mu$ s delay between two changes. For example to switch from 4.2 MHz to 32 MHz, you can switch from 4.2 MHz to 16 MHz, wait 5  $\mu$ s, then switch from 16 MHz to 32 MHz.
2. Should be USB compliant from I/O voltage standpoint, the minimum  $V_{DD}$  is 3.0 V.

**Table 3. CPU frequency range depending on dynamic voltage scaling**

CPU frequency range	Dynamic voltage scaling range
16 MHz to 32 MHz (1ws) 32 kHz to 16 MHz (0ws)	Range 1
8 MHz to 16 MHz (1ws) 32 kHz to 8 MHz (0ws)	Range 2
2.1MHz to 4.2 MHz (1ws) 32 kHz to 2.1 MHz (0ws)	Range 3

**Table 4. Functionalities depending on the working mode (from Run/active down to standby)**

Ips	Run/Active	Sleep	Low-power Run	Low-power Sleep	Stop		Standby	
					Wakeup capability	Wakeup capability		
CPU	Y	--	Y	--	--	--	--	--
Flash	Y	Y	Y	Y	--	--	--	--
RAM	Y	Y	Y	Y	Y	--	--	--
Backup Registers	Y	Y	Y	Y	Y	--	Y	--
EEPROM	Y	Y	Y	Y	Y	--	--	--
Brown-out rest (BOR)	Y	Y	Y	Y	Y	Y	Y	--
DMA	Y	Y	Y	Y	--	--	--	--
Programmable Voltage Detector (PVD)	Y	Y	Y	Y	Y	Y	Y	--
Power On Reset (POR)	Y	Y	Y	Y	Y	Y	Y	--
Power Down Rest (PDR)	Y	Y	Y	Y	Y	--	Y	--
High Speed Internal (HSI)	Y	Y	--	--	--	--	--	--
High Speed External (HSE)	Y	Y	--	--	--	--	--	--
Low Speed Internal (LSI)	Y	Y	Y	Y	Y	--	--	--
Low Speed External (LSE)	Y	Y	Y	Y	Y	--	--	--
Multi-Speed Internal (MSI)	Y	Y	Y	Y	--	--	--	--
Inter-Connect Controller	Y	Y	Y	Y	--	--	--	--
RTC	Y	Y	Y	Y	Y	Y	Y	--
RTC Tamper	Y	Y	Y	Y	Y	Y	Y	Y
Auto WakeUp (AWU)	Y	Y	Y	Y	Y	Y	Y	Y
LCD	Y	Y	Y	Y	Y	--	--	--
USB	Y	Y	--	--	--	Y	--	--
USART	Y	Y	Y	Y	Y	(1)	--	--
SPI	Y	Y	Y	Y	--	--	--	--
I2C	Y	Y	Y	Y	--	(1)	--	--

**Table 4. Functionalities depending on the working mode (from Run/active down to standby) (continued)**

Ips	Run/Active	Sleep	Low-power Run	Low-power Sleep	Stop		Standby	
					Wakeup capability	Wakeup capability		
ADC	Y	Y	--	--	--	--	--	--
DAC	Y	Y	Y	Y	Y	--	--	--
Tempsensor	Y	Y	Y	Y	Y	--	--	--
OP amp	Y	Y	Y	Y	Y	--	--	--
Comparators	Y	Y	Y	Y	Y	Y	--	--
16-bit and 32-bit Timers	Y	Y	Y	Y	--	--	--	--
IWDG	Y	Y	Y	Y	Y	Y	Y	Y
WWDG	Y	Y	Y	Y	--	--	--	--
Touch sensing	Y	Y	--	--	--	--	--	--
Systic Timer	Y	Y	Y	Y		--	--	--
GPIOs	Y	Y	Y	Y	Y	Y	--	3 pins
Wakeup time to Run mode	0 μs	0.4 μs	3 μs	46 μs	< 8 μs		58 μs	
Consumption V <sub>DD</sub> =1.8 to 3.6 V (Typ)	Down to 230 μA/MHz (from Flash)	Down to 43 μA/MHz (from Flash)	Down to 11 μA	Down to 4.4 μA	0.475 μA (no RTC) V <sub>DD</sub> =1.8V		0.305 μA (no RTC) V <sub>DD</sub> =1.8V	
					1.1 μA (with RTC) V <sub>DD</sub> =1.8V		0.82 μA (with RTC) V <sub>DD</sub> =1.8V	
					0.475 μA (no RTC) V <sub>DD</sub> =3.0V		0.305 μA (no RTC) V <sub>DD</sub> =3.0V	
					1.35 μA (with RTC) V <sub>DD</sub> =3.0V		1.15 μA (with RTC) V <sub>DD</sub> =3.0V	

1. The startup on communication line wakes the CPU which was made possible by an EXTI, this induces a delay before entering run mode.

### 3.2 ARM Cortex-M3 core with MPU

The ARM Cortex-M3 processor is the industry leading processor for embedded systems. It has been developed to provide a low-cost platform that meets the needs of MCU implementation, with a reduced pin count and low-power consumption, while delivering outstanding computational performance and an advanced system response to interrupts.

The ARM Cortex-M3 32-bit RISC processor features exceptional code-efficiency, delivering the high-performance expected from an ARM core in the memory size usually associated with 8- and 16-bit devices.

The memory protection unit (MPU) improves system reliability by defining the memory attributes (such as read/write access permissions) for different memory regions. It provides up to eight different regions and an optional predefined background region.

Owing to its embedded ARM core, the STM32L162xD is compatible with all ARM tools and software.

### **Nested vectored interrupt controller (NVIC)**

The ultra-low-power STM32L162xD embeds a nested vectored interrupt controller able to handle up to 56 maskable interrupt channels (not including the 16 interrupt lines of ARM Cortex-M3) and 16 priority levels.

- Closely coupled NVIC gives low-latency interrupt processing
- Interrupt entry vector table address passed directly to the core
- Closely coupled NVIC core interface
- Allows early processing of interrupts
- Processing of *late arriving*, higher-priority interrupts
- Support for tail-chaining
- Processor state automatically saved
- Interrupt entry restored on interrupt exit with no instruction overhead

This hardware block provides flexible interrupt management features with minimal interrupt latency.

## **3.3 Reset and supply management**

### **3.3.1 Power supply schemes**

- $V_{DD} = 1.65$  to  $3.6$  V: external power supply for I/Os and the internal regulator. Provided externally through  $V_{DD}$  pins.
- $V_{SSA}$ ,  $V_{DDA} = 1.65$  to  $3.6$  V: external analog power supplies for ADC, reset blocks, RCs and PLL (minimum voltage to be applied to  $V_{DDA}$  is  $1.8$  V when the ADC is used).  $V_{DDA}$  and  $V_{SSA}$  must be connected to  $V_{DD}$  and  $V_{SS}$ , respectively.

### **3.3.2 Power supply supervisor**

The device has an integrated ZEROPOWER power-on reset (POR)/power-down reset (PDR) that can be coupled with a brownout reset (BOR) circuitry.

The device exists in two versions:

- The version with BOR activated at power-on operates between  $1.8$  V and  $3.6$  V.
- The other version without BOR operates between  $1.65$  V and  $3.6$  V.

After the  $V_{DD}$  threshold is reached ( $1.65$  V or  $1.8$  V depending on the BOR which is active or not at power-on), the option byte loading process starts, either to confirm or modify default thresholds, or to disable the BOR permanently: in this case, the  $V_{DD}$  min value becomes  $1.65$  V (whatever the version, BOR active or not, at power-on).

When BOR is active at power-on, it ensures proper operation starting from  $1.8$  V whatever the power ramp-up phase before it reaches  $1.8$  V. When BOR is not active at power-up, the

power ramp-up should guarantee that 1.65 V is reached on  $V_{DD}$  at least 1 ms after it exits the POR area.

Five BOR thresholds are available through option bytes, starting from 1.8 V to 3 V. To reduce the power consumption in Stop mode, it is possible to automatically switch off the internal reference voltage ( $V_{REFINT}$ ) in Stop mode. The device remains in reset mode when  $V_{DD}$  is below a specified threshold,  $V_{POR/PDR}$  or  $V_{BOR}$ , without the need for any external reset circuit.

*Note:* The start-up time at power-on is typically 3.3 ms when BOR is active at power-up, the start-up time at power-on can be decreased down to 1 ms typically for devices with BOR inactive at power-up.

The device features an embedded programmable voltage detector (PVD) that monitors the  $V_{DD}/V_{DDA}$  power supply and compares it to the  $V_{PVD}$  threshold. This PVD offers 7 different levels between 1.85 V and 3.05 V, chosen by software, with a step around 200 mV. An interrupt can be generated when  $V_{DD}/V_{DDA}$  drops below the  $V_{PVD}$  threshold and/or when  $V_{DD}/V_{DDA}$  is higher than the  $V_{PVD}$  threshold. The interrupt service routine can then generate a warning message and/or put the MCU into a safe state. The PVD is enabled by software.

### 3.3.3 Voltage regulator

The regulator has three operation modes: main (MR), low-power (LPR) and power down.

- MR is used in Run mode (nominal regulation)
- LPR is used in the Low-power run, Low-power sleep and Stop modes
- Power down is used in Standby mode. The regulator output is high impedance, the kernel circuitry is powered down, inducing zero consumption but the contents of the registers and RAM are lost except for the standby circuitry (wake-up logic, IWDG, RTC, LSI, LSE crystal 32K osc, RCC\_CSR).

### 3.3.4 Boot modes

At startup, boot pins are used to select one of three boot options:

- Boot from Flash memory
- Boot from System memory
- Boot from embedded RAM

The boot from Flash usually boots at the beginning of the Flash (bank 1). An additional boot mechanism is available through user option byte, to allow booting from bank 2 when bank 2 contains valid code. This dual boot capability can be used to easily implement a secure field software update mechanism.

The boot loader is located in System memory. It is used to reprogram the Flash memory by using USART1, USART2 or USB. See Application note “STM32 microcontroller system memory boot mode” (AN2606) for details.

## 3.4 Clock management

The clock controller distributes the clocks coming from different oscillators to the core and the peripherals. It also manages clock gating for low-power modes and ensures clock robustness. It features:

- **Clock prescaler:** to get the best trade-off between speed and current consumption, the clock frequency to the CPU and peripherals can be adjusted by a programmable prescaler.
- **Safe clock switching:** clock sources can be changed safely on the fly in run mode through a configuration register.
- **Clock management:** to reduce power consumption, the clock controller can stop the clock to the core, individual peripherals or memory.
- **System clock source:** three different clock sources can be used to drive the master clock SYSCLK:
  - 1-24 MHz high-speed external crystal (HSE), that can supply a PLL
  - 16 MHz high-speed internal RC oscillator (HSI), trimmable by software, that can supply a PLL
  - Multispeed internal RC oscillator (MSI), trimmable by software, able to generate 7 frequencies (65 kHz, 131 kHz, 262 kHz, 524 kHz, 1.05 MHz, 2.1 MHz, 4.2 MHz). When a 32.768 kHz clock source is available in the system (LSE), the MSI frequency can be trimmed by software down to a  $\pm 0.5\%$  accuracy.
- **Auxiliary clock source:** two ultra-low-power clock sources that can be used to drive the LCD controller and the real-time clock:
  - 32.768 kHz low-speed external crystal (LSE)
  - 37 kHz low-speed internal RC (LSI), also used to drive the independent watchdog. The LSI clock can be measured using the high-speed internal RC oscillator for greater precision.
- **RTC and LCD clock sources:** the LSI, LSE or HSE sources can be chosen to clock the RTC and the LCD, whatever the system clock.
- **USB clock source:** the embedded PLL has a dedicated 48 MHz clock output to supply the USB interface.
- **Startup clock:** after reset, the microcontroller restarts by default with an internal 2 MHz clock (MSI). The prescaler ratio and clock source can be changed by the application program as soon as the code execution starts.
- **Clock security system (CSS):** this feature can be enabled by software. If a HSE clock failure occurs, the master clock is automatically switched to HSI and a software interrupt is generated if enabled.
- **Clock-out capability (MCO: microcontroller clock output):** it outputs one of the internal clocks for external use by the application.

Several prescalers allow the configuration of the AHB frequency, each APB (APB1 and APB2) domains. The maximum frequency of the AHB and the APB domains is 32 MHz. See [Figure 2](#) for details on the clock tree.

Figure 2. Clock tree

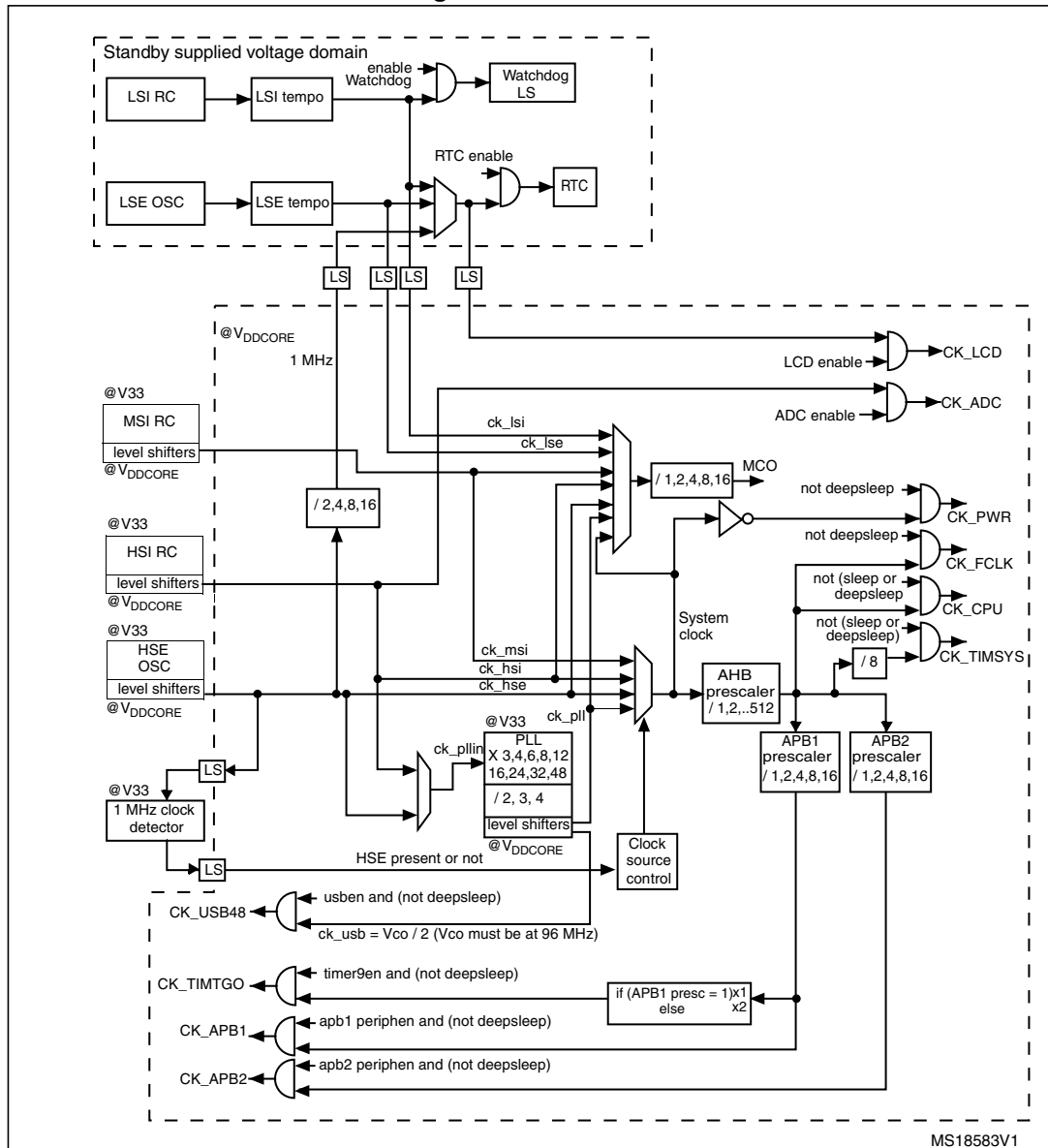

1. For the USB function to be available, both HSE and PLL must be enabled, with the CPU running at either 24 MHz or 32 MHz.

### 3.5 Low-power real-time clock and backup registers

The real-time clock (RTC) is an independent BCD timer/counter. Dedicated registers contain the sub-second, second, minute, hour (12/24 hour), week day, date, month, year, in BCD (binary-coded decimal) format. Correction for 28, 29 (leap year), 30, and 31 day of the month are made automatically. The RTC provides two programmable alarms and programmable periodic interrupts with wakeup from Stop and Standby modes.

The programmable wakeup time ranges from 120  $\mu$ s to 36 hours.

The RTC can be calibrated with an external 512 Hz output, and a digital compensation circuit helps reduce drift due to crystal deviation.

The RTC can also be automatically corrected with a 50/60Hz stable powerline.

The RTC calendar can be updated on the fly down to sub second precision, which enables network system synchronization.

A time stamp can record an external event occurrence, and generates an interrupt.

There are thirty-two 32-bit backup registers provided to store 128 bytes of user application data. They are cleared in case of tamper detection.

Three pins can be used to detect tamper events. A change on one of these pins can reset backup register and generate an interrupt. To prevent false tamper event, like ESD event, these three tamper inputs can be digitally filtered.

### 3.6 GPIOs (general-purpose inputs/outputs)

Each of the GPIO pins can be configured by software as output (push-pull or open-drain), as input (with or without pull-up or pull-down) or as peripheral alternate function. Most of the GPIO pins are shared with digital or analog alternate functions, and can be individually remapped using dedicated AFIO registers. All GPIOs are high current capable. The alternate function configuration of I/Os can be locked if needed following a specific sequence in order to avoid spurious writing to the I/O registers. The I/O controller is connected to the AHB with a toggling speed of up to 16 MHz.

#### External interrupt/event controller (EXTI)

The external interrupt/event controller consists of 24 edge detector lines used to generate interrupt/event requests. Each line can be individually configured to select the trigger event (rising edge, falling edge, both) and can be masked independently. A pending register maintains the status of the interrupt requests. The EXTI can detect an external line with a pulse width shorter than the Internal APB2 clock period. Up to 115 GPIOs can be connected to the 16 external interrupt lines. The 8 other lines are connected to RTC, PVD, USB, comparator events or capacitive sensing acquisition.

## 3.7 Memories

The STM32L162xD devices have the following features:

- 48 Kbytes of embedded RAM accessed (read/write) at CPU clock speed with 0 wait states. With the enhanced bus matrix, operating the RAM does not lead to any performance penalty during accesses to the system bus (AHB and APB buses).
- The non-volatile memory is divided into three arrays:
  - 384 Kbytes of embedded Flash program memory
  - 12 Kbytes of data EEPROM
  - Options bytes

Flash program and data EEPROM are divided into two banks, this enables writing in one bank while running code or reading data in the other bank.

The options bytes are used to write-protect or read-out protect the memory (with 4 KB granularity) and/or readout-protect the whole memory with the following options:

- Level 0: no readout protection
- Level 1: memory readout protection, the Flash memory cannot be read from or written to if either debug features are connected or boot in RAM is selected
- Level 2: chip readout protection, debug features (ARM Cortex-M3 JTAG and serial wire) and boot in RAM selection disabled (JTAG fuse)

The whole non-volatile memory embeds the error correction code (ECC) feature.

## 3.8 FSMC (flexible static memory controller)

The FSMC supports the following modes: SRAM, PSRAM, NOR/OneNAND Flash.

Functionality overview:

- Up to 26 bit address bus
- Up to 16-bit data bus
- Write FIFO
- Burst mode
- Code execution from external memory
- Four chip select signals
- Up to 32 MHz external access

## 3.9 DMA (direct memory access)

The flexible 12-channel, general-purpose DMA is able to manage memory-to-memory, peripheral-to-memory and memory-to-peripheral transfers. The DMA controller supports circular buffer management, avoiding the generation of interrupts when the controller reaches the end of the buffer.

Each channel is connected to dedicated hardware DMA requests, with software trigger support for each channel. Configuration is done by software and transfer sizes between source and destination are independent.

The DMA can be used with the main peripherals: AES, SPI, I<sup>2</sup>C, USART, SDIO, general-purpose timers, DAC and ADC.

### 3.10 LCD (liquid crystal display)

The LCD drives up to 8 common terminals and 44 segment terminals to drive up to 320 pixels.

- Internal step-up converter to guarantee functionality and contrast control irrespective of  $V_{DD}$ . This converter can be deactivated, in which case the  $V_{LCD}$  pin is used to provide the voltage to the LCD
- Supports static, 1/2, 1/3, 1/4 and 1/8 duty
- Supports static, 1/2, 1/3 and 1/4 bias
- Phase inversion to reduce power consumption and EMI
- Up to 8 pixels can be programmed to blink
- Unneeded segments and common pins can be used as general I/O pins
- LCD RAM can be updated at any time owing to a double-buffer
- The LCD controller can operate in Stop mode

### 3.11 ADC (analog-to-digital converter)

A 12-bit analog-to-digital converters is embedded into STM32L162xD devices with up to 40 external channels, performing conversions in single-shot or scan mode. In scan mode, automatic conversion is performed on a selected group of analog inputs with up to 28 external channels in a group.

The ADC can be served by the DMA controller.

An analog watchdog feature allows very precise monitoring of the converted voltage of one, some or all scanned channels. An interrupt is generated when the converted voltage is outside the programmed thresholds.

The events generated by the general-purpose timers (TIMx) can be internally connected to the ADC start triggers, to allow the application to synchronize A/D conversions and timers. An injection mode allows high priority conversions to be done by interrupting a scan mode which runs in as a background task.

The ADC includes a specific low-power mode. The converter is able to operate at maximum speed even if the CPU is operating at a very low frequency and has an auto-shutdown function. The ADC's runtime and analog front-end current consumption are thus minimized whatever the MCU operating mode.

#### 3.11.1 Temperature sensor

The temperature sensor (TS) generates a voltage  $V_{SENSE}$  that varies linearly with temperature.

The temperature sensor is internally connected to the ADC\_IN16 input channel which is used to convert the sensor output voltage into a digital value.

The sensor provides good linearity but it has to be calibrated to obtain good overall accuracy of the temperature measurement. As the offset of the temperature sensor varies from chip to chip due to process variation, the uncalibrated internal temperature sensor is suitable for applications that detect temperature changes only.

To improve the accuracy of the temperature sensor measurement, each device is individually factory-calibrated by ST. The temperature sensor factory calibration data are

stored by ST in the system memory area, accessible in read-only mode. See [Table 68: Temperature sensor calibration values](#).

### 3.11.2 Internal voltage reference ( $V_{REFINT}$ )

The internal voltage reference ( $V_{REFINT}$ ) provides a stable (bandgap) voltage output for the ADC and Comparators.  $V_{REFINT}$  is internally connected to the ADC\_IN17 input channel. It enables accurate monitoring of the  $V_{DD}$  value (when no external voltage,  $V_{REF+}$ , is available for ADC). The precise voltage of  $V_{REFINT}$  is individually measured for each part by ST during production test and stored in the system memory area. It is accessible in read-only mode. See [Table 14: Embedded internal reference voltage calibration values](#).

## 3.12 DAC (digital-to-analog converter)

The two 12-bit buffered DAC channels can be used to convert two digital signals into two analog voltage signal outputs. The chosen design structure is composed of integrated resistor strings and an amplifier in non-inverting configuration.

This dual digital Interface supports the following features:

- Two DAC converters: one for each output channel
- 8-bit or 12-bit monotonic output
- Left or right data alignment in 12-bit mode
- Synchronized update capability
- Noise-wave generation
- Triangular-wave generation
- Dual DAC channels, independent or simultaneous conversions
- DMA capability for each channel (including the underrun interrupt)
- External triggers for conversion
- Input reference voltage  $V_{REF+}$

Eight DAC trigger inputs are used in the STM32L162xD. The DAC channels are triggered through the timer update outputs that are also connected to different DMA channels.

## 3.13 Operational amplifier

The STM32L162xD embeds three operational amplifiers with external or internal follower routing capability (or even amplifier and filter capability with external components). When one operational amplifier is selected, one external ADC channel is used to enable output measurement.

The operational amplifiers feature:

- Low input bias current
- Low offset voltage
- Low-power mode
- Rail-to-rail input

### 3.14 Ultra-low-power comparators and reference voltage

The STM32L162xD embeds two comparators sharing the same current bias and reference voltage. The reference voltage can be internal or external (coming from an I/O).

- One comparator with fixed threshold
- One comparator with rail-to-rail inputs, fast or slow mode. The threshold can be one of the following:
  - DAC output
  - External I/O
  - Internal reference voltage ( $V_{REFINT}$ ) or a sub-multiple (1/4, 1/2, 3/4)

Both comparators can wake up from Stop mode, and be combined into a window comparator.

The internal reference voltage is available externally via a low-power / low-current output buffer (driving current capability of 1  $\mu$ A typical).

### 3.15 System configuration controller and routing interface

The system configuration controller provides the capability to remap some alternate functions on different I/O ports.

The highly flexible routing interface allows the application firmware to control the routing of different I/Os to the TIM2, TIM3 and TIM4 timer input captures. It also controls the routing of internal analog signals to ADC1, COMP1 and COMP2 and the internal reference voltage  $V_{REFINT}$ .

### 3.16 Touch sensing

The STM32L162xD devices provide a simple solution for adding capacitive sensing functionality to any application. These devices offer up to 34 capacitive sensing channels distributed over 11 analog I/O groups. Both software and timer capacitive sensing acquisition modes are supported.

Capacitive sensing technology is able to detect the presence of a finger near a sensor which is protected from direct touch by a dielectric (glass, plastic...). The capacitive variation introduced by the finger (or any conductive object) is measured using a proven implementation based on a surface charge transfer acquisition principle. It consists of charging the sensor capacitance and then transferring a part of the accumulated charges into a sampling capacitor until the voltage across this capacitor has reached a specific threshold. The capacitive sensing acquisition only requires few external components to operate. This acquisition is managed directly by the GPIOs, timers and analog I/O groups (see [Section 3.15: System configuration controller and routing interface](#)).

Reliable touch sensing functionality can be quickly and easily implemented using the free STM32L1xx STMTouch touch sensing firmware library.

### 3.17 AES

The AES Hardware Accelerator can be used to encrypt and decrypt data using the AES

algorithm (compatible with FIPS PUB 197, 2001 Nov 26).

- Key scheduler
- Key derivation for decryption
- 128-bit data block processed
- 128-bit key length
- 213 clock cycles to encrypt/decrypt one 128-bit block
- Electronic codebook (ECB), cypher block chaining (CBC), and counter mode (CTR) supported by hardware.

AES data flow can be served by 2ch (D<sub>IN</sub>/D<sub>OUT</sub>) of the DMA2 controller

### 3.18 Timers and watchdogs

The ultra-low-power STM32L162xD devices include seven general-purpose timers, two basic timers, and two watchdog timers.

*Table 5* compares the features of the general-purpose and basic timers.

**Table 5. Timer feature comparison**

Timer	Counter resolution	Counter type	Prescaler factor	DMA request generation	Capture/compare channels	Complementary outputs
TIM2, TIM3, TIM4	16-bit	Up, down, up/down	Any integer between 1 and 65536	Yes	4	No
TIM5	32-bit	Up, down, up/down	Any integer between 1 and 65536	Yes	4	No
TIM9	16-bit	Up, down, up/down	Any integer between 1 and 65536	No	2	No
TIM10, TIM11	16-bit	Up	Any integer between 1 and 65536	No	1	No
TIM6, TIM7	16-bit	Up	Any integer between 1 and 65536	Yes	0	No

#### 3.18.1 General-purpose timers (TIM2, TIM3, TIM4, TIM5, TIM9, TIM10 and TIM11)

There are seven synchronizable general-purpose timers embedded in the STM32L162xD devices (see *Table 5* for differences).

##### TIM2, TIM3, TIM4, TIM5

TIM2, TIM3, TIM4 are based on 16-bit auto-reload up/down counter. TIM5 is based on a 32-bit auto-reload up/down counter. They include a 16-bit prescaler. They feature four independent channels each for input capture/output compare, PWM or one-pulse mode output. This gives up to 16 input captures/output compares/PWMs on the largest packages.

TIM2, TIM3, TIM4, TIM5 general-purpose timers can work together or with the TIM10, TIM11 and TIM9 general-purpose timers via the Timer Link feature for synchronization or

event chaining. Their counter can be frozen in debug mode. Any of the general-purpose timers can be used to generate PWM outputs.

TIM2, TIM3, TIM4, TIM5 all have independent DMA request generation.

These timers are capable of handling quadrature (incremental) encoder signals and the digital outputs from 1 to 3 hall-effect sensors.

### **TIM10, TIM11 and TIM9**

TIM10 and TIM11 are based on a 16-bit auto-reload upcounter. TIM9 is based on a 16-bit auto-reload up/down counter. They include a 16-bit prescaler. TIM10 and TIM11 feature one independent channel, whereas TIM9 has two independent channels for input capture/output compare, PWM or one-pulse mode output. They can be synchronized with the TIM2, TIM3, TIM4, TIM5 full-featured general-purpose timers.

They can also be used as simple time bases and be clocked by the LSE clock source (32.768 kHz) to provide time bases independent from the main CPU clock.

### **3.18.2 Basic timers (TIM6 and TIM7)**

These timers are mainly used for DAC trigger generation. They can also be used as generic 16-bit time bases.

### **3.18.3 SysTick timer**

This timer is dedicated to the OS, but could also be used as a standard downcounter. It is based on a 24-bit downcounter with autoreload capability and a programmable clock source. It features a maskable system interrupt generation when the counter reaches 0.

### **3.18.4 Independent watchdog (IWDG)**

The independent watchdog is based on a 12-bit downcounter and 8-bit prescaler. It is clocked from an independent 37 kHz internal RC and, as it operates independently of the main clock, it can operate in Stop and Standby modes. It can be used either as a watchdog to reset the device when a problem occurs, or as a free-running timer for application timeout management. It is hardware- or software-configurable through the option bytes. The counter can be frozen in debug mode.

### **3.18.5 Window watchdog (WWDG)**

The window watchdog is based on a 7-bit downcounter that can be set as free-running. It can be used as a watchdog to reset the device when a problem occurs. It is clocked from the main clock. It has an early warning interrupt capability and the counter can be frozen in debug mode.

## **3.19 Communication interfaces**

### **3.19.1 I<sup>2</sup>C bus**

Up to two I<sup>2</sup>C bus interfaces can operate in multimaster and slave modes. They can support standard and fast modes.

They support dual slave addressing (7-bit only) and both 7- and 10-bit addressing in master mode. A hardware CRC generation/verification is embedded.

They can be served by DMA and they support SM Bus 2.0/PM Bus.

### 3.19.2 Universal synchronous/asynchronous receiver transmitter (USART)

The three USART and two UART interfaces are able to communicate at speeds of up to 4 Mbit/s. They support IrDA SIR ENDEC and have LIN Master/Slave capability. The three USARTs provide hardware management of the CTS and RTS signals and are ISO 7816 compliant.

All USART/UART interfaces can be served by the DMA controller.

### 3.19.3 Serial peripheral interface (SPI)

Up to three SPIs are able to communicate at up to 16 Mbits/s in slave and master modes in full-duplex and half-duplex communication modes. The 3-bit prescaler gives 8 master mode frequencies and the frame is configurable to 8 bits or 16 bits. The hardware CRC generation/verification supports basic SD Card/MMC modes.

The SPIs can be served by the DMA controller.

### 3.19.4 Inter-integrated sound (I<sup>2</sup>S)

Two standard I2S interfaces (multiplexed with SPI2 and SPI3) are available. They can operate in master or slave mode, and can be configured to operate with a 16-/32-bit resolution as input or output channels. Audio sampling frequencies from 8 kHz up to 192 kHz are supported. When either or both of the I2S interfaces is/are configured in master mode, the master clock can be output to the external DAC/CODEC at 256 times the sampling frequency.

The I2Ss can be served by the DMA controller.

### 3.19.5 SDIO

An SD/SDIO/MMC host interface is available, that supports MultiMediaCard System Specification Version 4.2 in three different databus modes: 1-bit (default), 4-bit and 8-bit.

The interface allows data transfer at up to 24 MHz in 8-bit mode, and is compliant with the SD Memory Card Specification Version 2.0.

The SDIO Card Specification Version 2.0 is also supported with two different databus modes: 1-bit (default) and 4-bit.

The current version supports only one SD/SDIO/MMC4.2 card at any one time and a stack of MMC4.1 or previous.

In addition to SD/SDIO/MMC, this interface is fully compliant with the CE-ATA digital protocol Rev1.1.

### 3.19.6 Universal serial bus (USB)

The STM32L162xD embeds a USB device peripheral compatible with the USB full-speed 12 Mbit/s. The USB interface implements a full-speed (12 Mbit/s) function interface. It has software-configurable endpoint setting and supports suspend/resume. The dedicated

48 MHz clock is generated from the internal main PLL (the clock source must use a HSE crystal oscillator).

## 3.20 CRC (cyclic redundancy check) calculation unit

The CRC (cyclic redundancy check) calculation unit is used to get a CRC code from a 32-bit data word and a fixed generator polynomial.

Among other applications, CRC-based techniques are used to verify data transmission or storage integrity. In the scope of the EN/IEC 60335-1 standard, they offer a means of verifying the Flash memory integrity. The CRC calculation unit helps compute a signature of the software during runtime, to be compared with a reference signature generated at link-time and stored at a given memory location.

## 3.21 Development support

### 3.21.1 Serial wire JTAG debug port (SWJ-DP)

The ARM SWJ-DP interface is embedded, and is a combined JTAG and serial wire debug port that enables either a serial wire debug or a JTAG probe to be connected to the target. The JTAG JTMS and JTCK pins are shared with SWDAT and SWCLK, respectively, and a specific sequence on the JTMS pin is used to switch between JTAG-DP and SW-DP.

The JTAG port can be permanently disabled with a JTAG fuse.

### 3.21.2 Embedded Trace Macrocell™

The ARM® Embedded Trace Macrocell provides a greater visibility of the instruction and data flow inside the CPU core by streaming compressed data at a very high rate from the STM32L162xD through a small number of ETM pins to an external hardware trace port analyzer (TPA) device. The TPA is connected to a host computer using USB, Ethernet, or any other high-speed channel. Real-time instruction and data flow activity can be recorded and then formatted for display on the host computer running debugger software. TPA hardware is commercially available from common development tool vendors. It operates with third party debugger software tools.

# 4 Pin descriptions

Figure 3. STM32L162ZD LQFP144 pinout

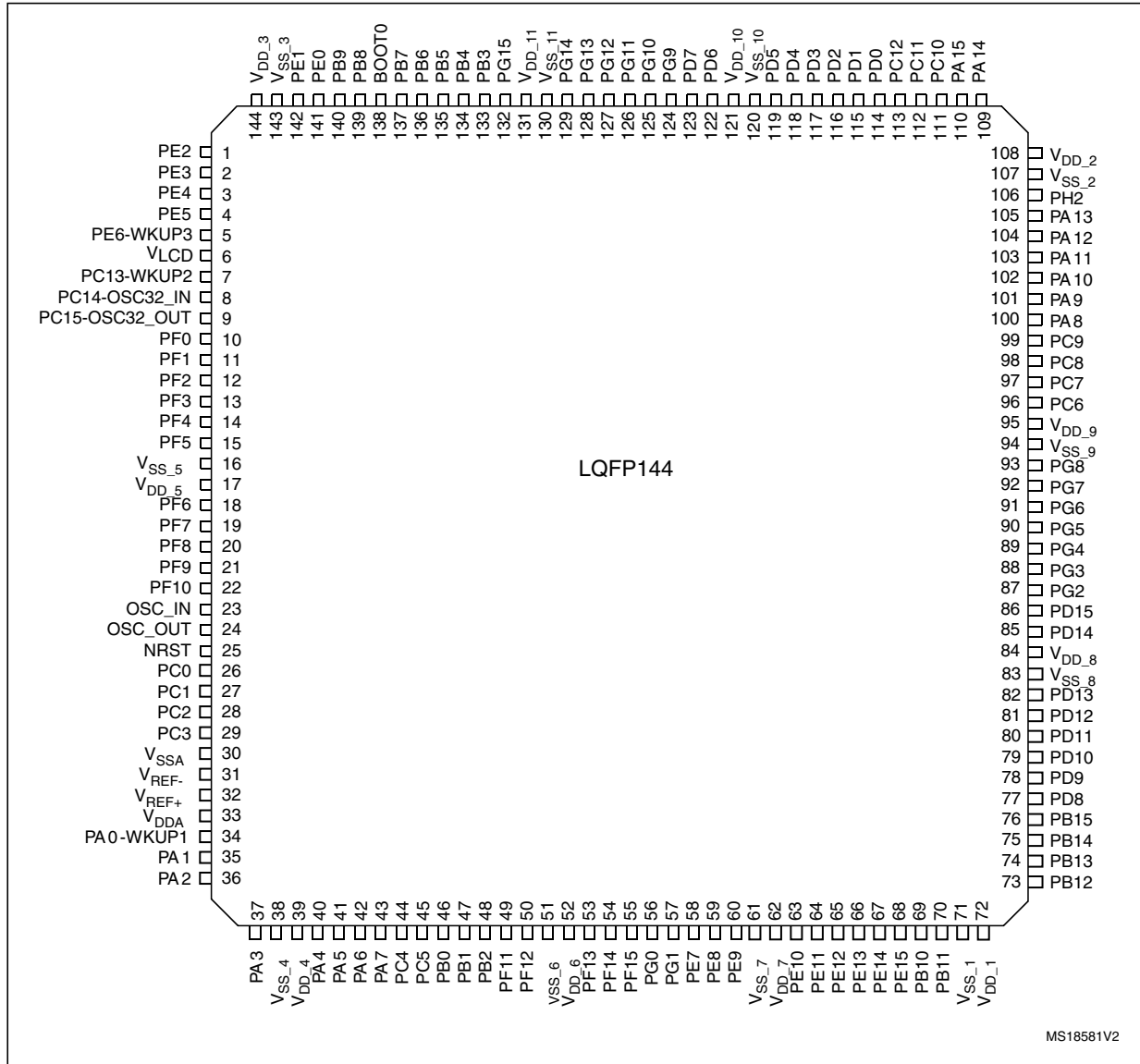

1. This figure shows the package top view.

Figure 4. STM32L162QD UFBGA132 ballout

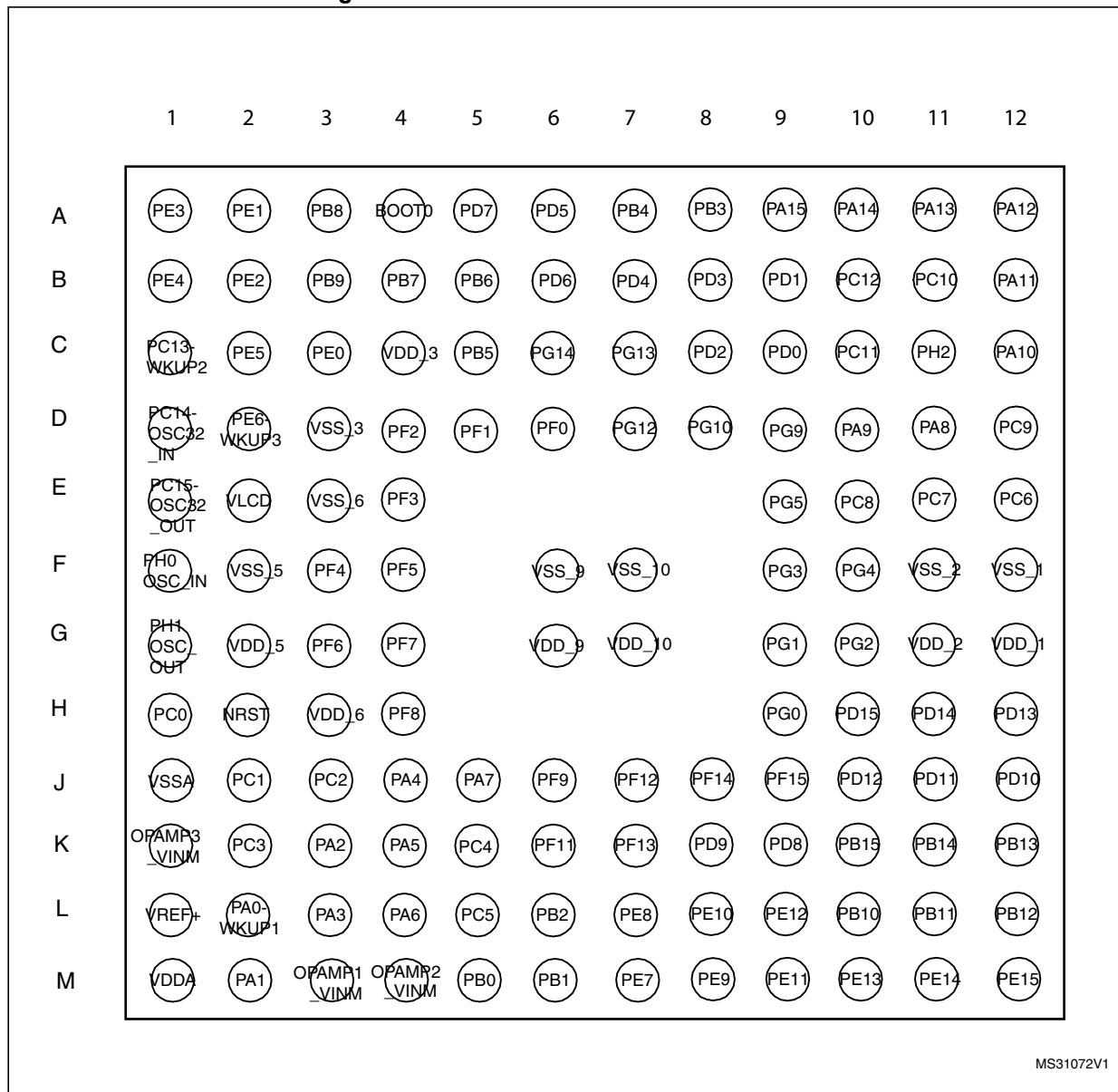

MS31072V1

1. This figure shows the package top view.

Figure 5. STM32L162VD LQFP100 pinout

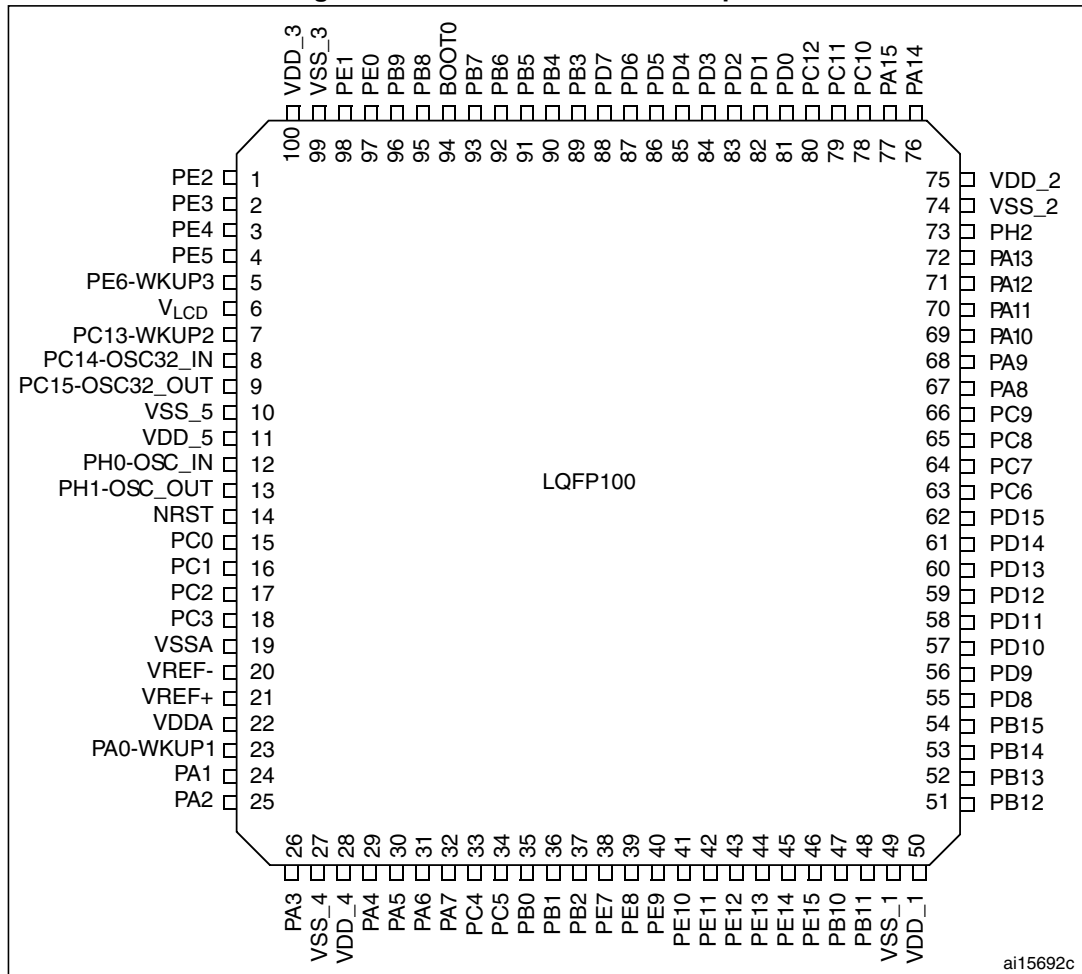

1. This figure shows the package top view

Figure 6. STM32L162RD LQFP64 pinout

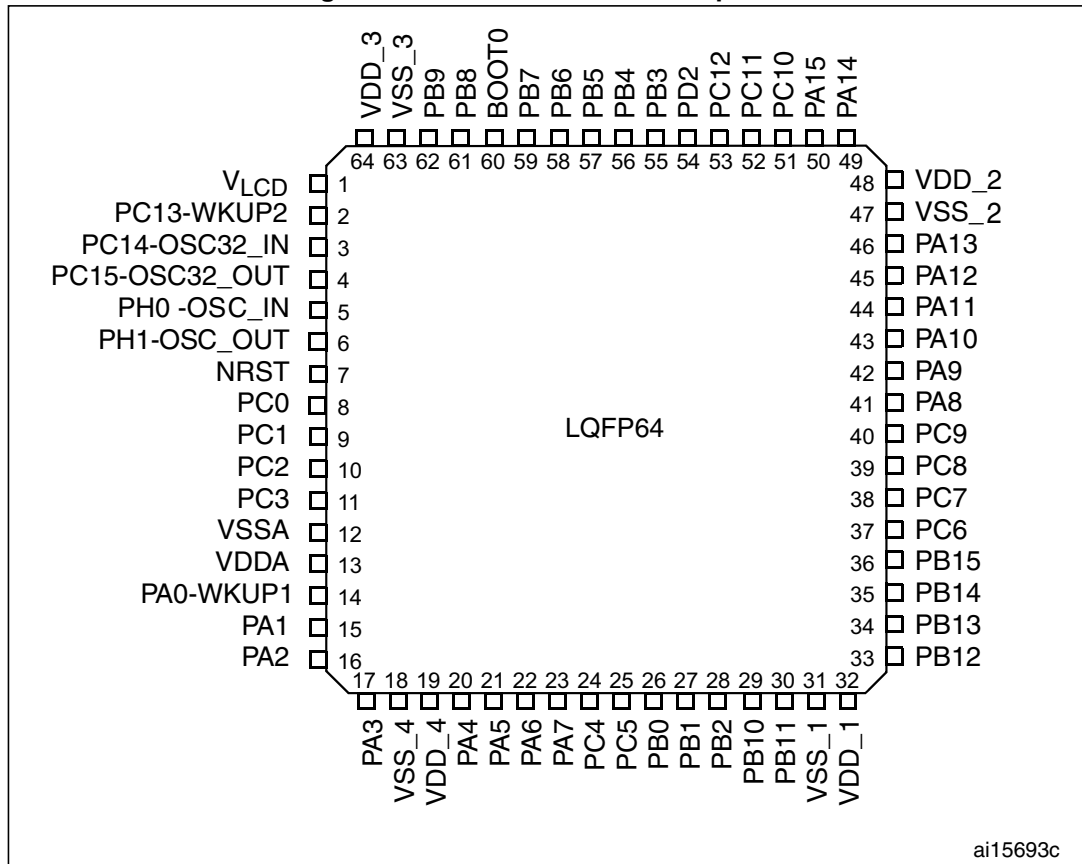

1. This figure shows the package top view.

Figure 7. STM32L162RD WLCSP64 ballout

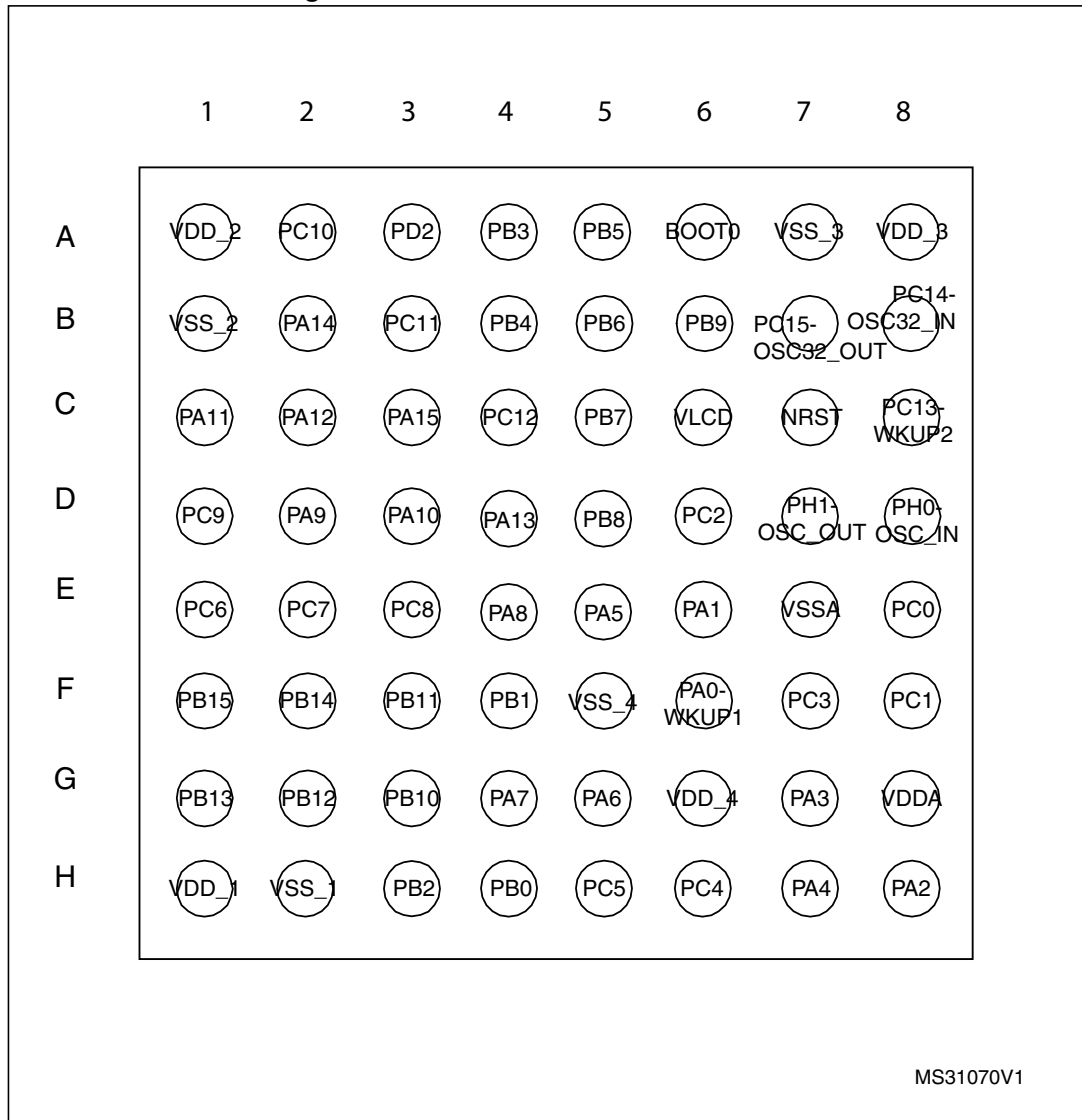

1. This figure shows the package top view.

**Table 6. Legend/abbreviations used in the pinout table**

Name		Abbreviation	Definition
Pin name		Unless otherwise specified in brackets below the pin name, the pin function during and after reset is the same as the actual pin name	
Pin type	S		Supply pin
	I		Input only pin
	I/O		Input / output pin
I/O structure	FT		5 V tolerant I/O
	TC		Standard 3.3 V I/O
	B		Dedicated BOOT0 pin
	RST		Bidirectional reset pin with embedded weak pull-up resistor
Notes		Unless otherwise specified by a note, all I/Os are set as floating inputs during and after reset	
Pin functions	Alternate functions	Functions selected through GPIOx_AFR registers	
	Additional functions	Functions directly selected/enabled through peripheral registers	

Table 7. STM32L162xD pin definitions

Pins					Pin name	Type <sup>(1)</sup>	I / O Level <sup>(2)</sup>	Main function <sup>(3)</sup> (after reset)	Pin functions	
LQFP144	UFBGA132	LQFP100	LQFP64	WLCSP64					Alternate functions	Additional functions
1	B2	1	-	-	PE2	I/O	FT	PE2	TIM3_ETR/LCD_SEG38/ FSMC_A23/TRACECLK	
2	A1	2	-	-	PE3	I/O	FT	PE3	TIM3_CH1/LCD_SEG39/ FSMC_A19/TRACED0	
3	B1	3	-	-	PE4	I/O	FT	PE4	TIM3_CH2/FSMC_A20/ TRACED1	
4	C2	4	-	-	PE5	I/O	FT	PE5	TIM9_CH1/TRACED2 /FSMC_A21	
5	D2	5	-	-	PE6- WKUP3	I/O	FT	PE6	TIM9_CH2/TRACED3	WKUP3/ RTC_TAMP3
6	E2	6	1	C6	V <sub>LCD</sub>	S		V <sub>LCD</sub>		
7	C1	7	2	C8	PC13-WKUP2	I/O	FT	PC13		WKUP2/ RTC_TAMP1/ RTC_TS/ RTC_OUT
8	D1	8	3	B8	PC14- OSC32_IN <sup>(4)</sup>	I/O		PC14		OSC32_IN
9	E1	9	4	B7	PC15- OSC32_OUT	I/O		PC15		OSC32_OUT
10	D6	-	-	-	PF0	I/O	FT	PF0	FSMC_A0	
11	D5	-	-	-	PF1	I/O	FT	PF1	FSMC_A1	
12	D4	-	-	-	PF2	I/O	FT	PF2	FSMC_A2	
13	E4	-	-	-	PF3	I/O	FT	PF3	FSMC_A3	
14	F3	-	-	-	PF4	I/O	FT	PF4	FSMC_A4	
15	F4	-	-	-	PF5	I/O	FT	PF5	FSMC_A5	
16	F2	10	-	-	V <sub>SS_5</sub>	S		V <sub>SS_5</sub>		
17	G2	11	-	-	V <sub>DD_5</sub>	S		V <sub>DD_5</sub>		
18	G3	-	-	-	PF6	I/O	FT	PF6	TIM5_CH1/TIM5_ETR	ADC_IN27
19	G4	-	-	-	PF7	I/O	FT	PF7	TIM5_CH2	ADC_IN28/ COMP1_INP

Table 7. STM32L162xD pin definitions (continued)

Pins					Pin name	Type <sup>(1)</sup>	I / O Level <sup>(2)</sup>	Main function <sup>(3)</sup> (after reset)	Pin functions	
LQFP144	UFBGA132	LQFP100	LQFP64	WLCSP64					Alternate functions	Additional functions
20	H4	-	-	-	PF8	I/O	FT	PF8	TIM5_CH3	ADC_IN29/ COMP1_INP
21	J6	-	-	-	PF9	I/O	FT	PF9	TIM5_CH4	ADC_IN30/ COMP1_INP
22	-	-	-	-	PF10	I/O	FT	PF10		ADC_IN31/ COMP1_INP
23	F1	12	5	D8	PH0-OSC_IN <sup>(5)</sup>	I/O		PH0		OSC_IN
24	G1	13	6	D7	PH1- OSC_OUT <sup>(5)</sup>	I/O		PH1		OSC_OUT
25	H2	14	7	C7	NRST	I/O		NRST		
26	H1	15	8	E8	PC0	I/O	FT	PC0	LCD_SEG18	ADC_IN10/ COMP1_INP
27	J2	16	9	F8	PC1	I/O	FT	PC1	LCD_SEG19	ADC_IN11/ COMP1_INP/ OPAMP3_VINP
28	-	17	10	D6	PC2	I/O	FT	PC2	LCD_SEG20	ADC_IN12/ COMP1_INP/ OPAMP3_VINM
-	J3	-	-	-	PC2	I/O	FT	PC2	LCD_SEG20	ADC_IN12/ COMP1_INP
-	K1	-	-	-	OPAMP3_VINM	I		OPAMP3_VINM		
29	K2	18	11	F7	PC3	I/O		PC3	LCD_SEG21	ADC_IN13/ COMP1_INP/ OPAMP3_VOUT
30	J1	19	12	E7	V <sub>SSA</sub>	S		V <sub>SSA</sub>		
31	-	20	-	-	V <sub>REF-</sub>	S		V <sub>REF-</sub>		
32	L1	21	-	-	V <sub>REF+</sub>	S		V <sub>REF+</sub>		
33	M1	22	13	G8	V <sub>DDA</sub>	S		V <sub>DDA</sub>		
34	L2	23	14	F6	PA0-WKUP1	I/O	FT	PA0	TIM2_CH1_ETR/ TIM5_CH1/ USART2_CTS	WKUP1/ RTC_TAMP2/ ADC_IN0 /COMP1_INP

Table 7. STM32L162xD pin definitions (continued)

Pins					Pin name	Type <sup>(1)</sup>	I/O Level <sup>(2)</sup>	Main function <sup>(3)</sup> (after reset)	Pin functions	
LQFP144	UFBGA132	LQFP100	LQFP64	WLCSP64					Alternate functions	Additional functions
35	M2	24	15	E6	PA1	I/O	FT	PA1	TIM2_CH2/TIM5_CH2/ USART2_RTS /LCD_SEG0	ADC_IN1/ COMP1_INP/ OPAMP1_VINP
36	-	25	16	H8	PA2	I/O	FT	PA2	TIM2_CH3/TIM5_CH3/ TIM9_CH1/USART2_TX /LCD_SEG1	ADC_IN2/ COMP1_INP/ OPAMP1_VINM
-	K3	-	-	-	PA2	I/O	FT	PA2	TIM2_CH3/TIM5_CH3/ TIM9_CH1/USART2_TX/ LCD_SEG1	ADC_IN2/ COMP1_INP
-	M3	-	-	-	OPAMP1_VINM	I		OPAMP1_VINM		
37	L3	26	17	G7	PA3	I/O		PA3	TIM2_CH4/TIM5_CH4/ TIM9_CH2/ USART2_RX/LCD_SEG2	ADC_IN3/ COMP1_INP/ OPAMP1_VOUT
38	-	27	18	F5	V <sub>SS_4</sub>	S		V <sub>SS_4</sub>		
39	-	28	19	G6	V <sub>DD_4</sub>	S		V <sub>DD_4</sub>		
40	J4	29	20	H7	PA4	I/O		PA4	SPI1_NSS/SPI3_NSS/ I2S3_WS/USART2_CK	ADC_IN4/ DAC_OUT/ COMP1_INP
41	K4	30	21	E5	PA5	I/O		PA5	TIM2_CH1_ETR/ SPI1_SCK	ADC_IN5/ DAC_OUT2/ COMP1_INP
42	L4	31	22	G5	PA6	I/O	FT	PA6	TIM3_CH1/TIM10_CH1/ SPI1_MISO/LCD_SEG3	ADC_IN6/ COMP1_INP/ OPAMP2_VINP
43	-	32	23	G4	PA7	I/O	FT	PA7	TIM3_CH2/TIM11_CH1/ SPI1_MOSI/LCD_SEG4	ADC_IN7/ COMP1_INP/ OPAMP2_VINM
-	J5	-	-	-	PA7	I/O	FT	PA7	TIM3_CH2/TIM11_CH1/ SPI1_MOSI/ LCD_SEG4	ADC_IN7/ COMP1_INP
-	M4	-	-	-	OPAMP2_VINM	I		OPAMP2_VINM		
44	K5	33	24	H6	PC4	I/O	FT	PC4	LCD_SEG22	ADC_IN14/ COMP1_INP

Table 7. STM32L162xD pin definitions (continued)

Pins					Pin name	Type <sup>(1)</sup>	I/O Level <sup>(2)</sup>	Main function <sup>(3)</sup> (after reset)	Pin functions	
LQFP144	UFBGA132	LQFP100	LQFP64	WLCSP64					Alternate functions	Additional functions
45	L5	34	25	H5	PC5	I/O	FT	PC5	LCD_SEG23	ADC_IN15/ COMP1_INP
46	M5	35	26	H4	PB0	I/O		PB0	TIM3_CH3/LCD_SEG5	ADC_IN8/ COMP1_INP/ OPAMP2_VOUT/ VREF_OUT
47	M6	36	27	F4	PB1	I/O	FT	PB1	TIM3_CH4/LCD_SEG6	ADC_IN9/ COMP1_INP// VREF_OUT
-	-	37	28	H3	PB2	I/O	FT	PB2/BOOT1	BOOT1	COMP1_INP
48	L6				PB2	I/O	FT	PB2/BOOT1	BOOT1	ADC_IN0b/ COMP1_INP
49	K6	-	-	-	PF11	I/O	FT	PF11		ADC_IN1b/ COMP1_INP
50	J7	-	-	-	PF12	I/O	FT	PF12	FSMC_A6	ADC_IN2b/ COMP1_INP
51	E3	-	-	-	V <sub>SS_6</sub>	S		V <sub>SS_6</sub>		
52	H3	-	-	-	V <sub>DD_6</sub>	S		V <sub>DD_6</sub>		
53	K7	-	-	-	PF13	I/O	FT	PF13	FSMC_A7	ADC_IN3b/ COMP1_INP
54	J8	-	-	-	PF14	I/O	FT	PF14	FSMC_A8	ADC_IN6b/ COMP1_INP
55	J9	-	-	-	PF15	I/O	FT	PF15	FSMC_A9	ADC_IN7b/ COMP1_INP
56	H9	-	-	-	PG0	I/O	FT	PG0	FSMC_A10	ADC_IN8b/ COMP1_INP
57	G9	-	-	-	PG1	I/O	FT	PG1	FSMC_A11	ADC_IN9b/ COMP1_INP
58	M7	38	-	-	PE7	I/O		PE7	FSMC_D4	ADC_IN22/ COMP1_INP
59	L7	39	-	-	PE8	I/O		PE8	FSMC_D5	ADC_IN23/ COMP1_INP
60	M8	40	-	-	PE9	I/O		PE9	TIM2_CH1_ETR /FSMC_D6	ADC_IN24 /COMP1_INP

Table 7. STM32L162xD pin definitions (continued)

Pins					Pin name	Type <sup>(1)</sup>	I/O Level <sup>(2)</sup>	Main function <sup>(3)</sup> (after reset)	Pin functions	
LQFP144	UFBGA132	LQFP100	LQFP64	WLCSP64					Alternate functions	Additional functions
61	-	-	-	-	V <sub>SS_7</sub>	S		V <sub>SS_7</sub>		
62	-	-	-	-	V <sub>DD_7</sub>	S		V <sub>DD_7</sub>		
63	L8	41	-	-	PE10	I/O		PE10	TIM2_CH2/FSMC_D7	ADC_IN25/ COMP1_INP
64	M9	42	-	-	PE11	I/O	FT	PE11	TIM2_CH3/FSMC_D8	
65	L9	43	-	-	PE12	I/O	FT	PE12	TIM2_CH4/SPI1_NSS /FSMC_D9	
66	M10	44	-	-	PE13	I/O	FT	PE13	SPI1_SCK/FSMC_D10	
67	M11	45	-	-	PE14	I/O	FT	PE14	SPI1_MISO/FSMC_D11	
68	M12	46	-	-	PE15	I/O	FT	PE15	SPI1_MOSI/FSMC_D12	
69	L10	47	29	G3	PB10	I/O	FT	PB10	TIM2_CH3/I2C2_SCL/ USART3_TX/ LCD_SEG10	
70	L11	48	30	F3	PB11	I/O	FT	PB11	TIM2_CH4/I2C2_SDA/ USART3_RX/ LCD_SEG11	
71	F12	49	31	H2	V <sub>SS_1</sub>	S		V <sub>SS_1</sub>		
72	G12	50	32	H1	V <sub>DD_1</sub>	S		V <sub>DD_1</sub>		
73	L12	51	33	G2	PB12	I/O	FT	PB12	TIM10_CH1/I2C2_SMBA/ SPI2_NSS/I2S2_WS/ USART3_CK/ LCD_SEG12	ADC_IN18/ COMP1_INP
74	K12	52	34	G1	PB13	I/O	FT	PB13	TIM9_CH1/SPI2_SCK/ I2S2_CK/ USART3_CTS/ LCD_SEG13	ADC_IN19/ COMP1_INP
75	K11	53	35	F2	PB14	I/O	FT	PB14	TIM9_CH2/SPI2_MISO/ USART3_RTS/ LCD_SEG14	ADC_IN20/ COMP1_INP
76	K10	54	36	F1	PB15	I/O	FT	PB15	TIM11_CH1/SPI2_MOSI/ I2S2_SD/ LCD_SEG15	ADC_IN21/ COMP1_INP/ RTC_REFIN
77	K9	55	-	-	PD8	I/O	FT	PD8	USART3_TX/ LCD_SEG28/FSMC_D13	

Table 7. STM32L162xD pin definitions (continued)

Pins					Pin name	Type <sup>(1)</sup>	I / O Level <sup>(2)</sup>	Main function <sup>(3)</sup> (after reset)	Pin functions	
LQFP144	UFBGA132	LQFP100	LQFP64	WLCSP64					Alternate functions	Additional functions
78	K8	56	-	-	PD9	I/O	FT	PD9	USART3_RX/ LCD_SEG29/FSMC_D14	
79	J12	57	-	-	PD10	I/O	FT	PD10	USART3_CK/ LCD_SEG30/FSMC_D15	
80	J11	58	-	-	PD11	I/O	FT	PD11	USART3_CTS/ LCD_SEG31/FSMC_A16	
81	J10	59	-	-	PD12	I/O	FT	PD12	TIM4_CH1 /USART3_RTS/ LCD_SEG32/FSMC_A17	
82	H12	60	-	-	PD13	I/O	FT	PD13	TIM4_CH2/LCD_SEG33/ FSMC_A18	
83	-	-	-	-	V <sub>SS_8</sub>	S		V <sub>SS_8</sub>		
84	-	-	-	-	V <sub>DD_8</sub>	S		V <sub>DD_8</sub>		
85	H11	61	-	-	PD14	I/O	FT	PD14	TIM4_CH3/LCD_SEG34/ FSMC_D0	
86	H10	62	-	-	PD15	I/O	FT	PD15	TIM4_CH4/LCD_SEG35/ FSMC_D1	
87	G10	-	-	-	PG2	I/O	FT	PG2	FSMC_A12	ADC_IN10b/ COMP1_INP
88	F9	-	-	-	PG3	I/O	FT	PG3	FSMC_A13	ADC_IN11b/ COMP1_INP
89	F10	-	-	-	PG4	I/O	FT	PG4	FSMC_A14	ADC_IN12b/ COMP1_INP
90	E9	-	-	-	PG5	I/O	FT	PG5	FSMC_A15	
91	-	-	-	-	PG6	I/O	FT	PG6		
92	-	-	-	-	PG7	I/O	FT	PG7		
93	-	-	-	-	PG8	I/O	FT	PG8		
94	F6	-	-	-	V <sub>SS_9</sub>	S		V <sub>SS_9</sub>		
95	G6	-	-	-	V <sub>DD_9</sub>	S		V <sub>DD_9</sub>		
96	E12	63	37	E1	PC6	I/O	FT	PC6	TIM3_CH1/I2S2_MCK/ LCD_SEG24/SDIO_D6	
97	E11	64	38	E2	PC7	I/O	FT	PC7	TIM3_CH2/I2S3_MCK/ LCD_SEG25/SDIO_D7	

Table 7. STM32L162xD pin definitions (continued)

Pins					Pin name	Type <sup>(1)</sup>	I / O Level <sup>(2)</sup>	Main function <sup>(3)</sup> (after reset)	Pin functions	
LQFP144	UFBGA132	LQFP100	LQFP64	WLCSP64					Alternate functions	Additional functions
98	E10	65	39	E3	PC8	I/O	FT	PC8	TIM3_CH3/LCD_SEG26/ SDIO_D0	
99	D12	66	40	D1	PC9	I/O	FT	PC9	TIM3_CH4/LCD_SEG27/ SDIO_D1	
100	D11	67	41	E4	PA8	I/O	FT	PA8	USART1_CK/MCO/ LCD_COM0	
101	D10	68	42	D2	PA9	I/O	FT	PA9	USART1_TX/ LCD_COM1	
102	C12	69	43	D3	PA10	I/O	FT	PA10	USART1_RX/ LCD_COM2	
103	B12	70	44	C1	PA11	I/O	FT	PA11	USART1_CTS/ SPI1_MISO	USB_DM
104	A12	71	45	C2	PA12	I/O	FT	PA12	USART1_RTS/ SPI1_MOSI	USB_DP
105	A11	72	46	D4	PA13	I/O	FT	JTMS- SWDIO	JTMS-SWDIO	
106	C11	73	-	-	PH2	I/O	FT	PH2	FSMC_A22	
107	F11	74	47	B1	V <sub>SS_2</sub>	S		V <sub>SS_2</sub>		
108	G11	75	48	A1	V <sub>DD_2</sub>	S		V <sub>DD_2</sub>		
109	A10	76	49	B2	PA14	I/O	FT	JTCK- SWCLK	JTCK-SWCLK	
110	A9	77	50	C3	PA15	I/O	FT	JTDI	TIM2_CH1_ETR/ SPI1_NSS/SPI3_NSS/ I2S3_WS/LCD_SEG17/ JTDI	
111	B11	78	51	A2	PC10	I/O	FT	PC10	SPI3_SCK/I2S3_CK/ USART3_TX/ UART4_TX/LCD_SEG28/ LCD_SEG40/ LCD_COM4/SDIO_D2	
112	C10	79	52	B3	PC11	I/O	FT	PC11	SPI3_MISO/USART3_RX /UART4_RX/ LCD_SEG29/ LCD_SEG41/LCD_COM5 /SDIO_D3	

Table 7. STM32L162xD pin definitions (continued)

Pins					Pin name	Type <sup>(1)</sup>	I / O Level <sup>(2)</sup>	Main function <sup>(3)</sup> (after reset)	Pin functions	
LQFP144	UFBGA132	LQFP100	LQFP64	WLCSP64					Alternate functions	Additional functions
113	B10	80	53	C4	PC12	I/O	FT	PC12	SPI3_MOSI/I2S3_SD/ USART3_CK/ UART5_TX/LCD_SEG30/ LCD_SEG42/ LCD_COM6/SDIO_CK	
114	C9	81	-	-	PD0	I/O	FT	PD0	TIM9_CH1/SPI2_NSS/ I2S2_WS/FSMC_D2	
115	B9	82	-	-	PD1	I/O	FT	PD1	SPI2_SCK/I2S2_CK /FSMC_D3	
116	C8	83	54	A3	PD2	I/O	FT	PD2	TIM3_ETR/UART5_RX/ LCD_SEG31/ LCD_SEG43/LCD_COM7 /SDIO_CMD	
117	B8	84	-	-	PD3	I/O	FT	PD3	SPI2_MISO/ USART2_CTS /FSMC_CLK	
118	B7	85	-	-	PD4	I/O	FT	PD4	SPI2_MOSI/I2S2_SD/ USART2_RTS /FSMC_NOE	
119	A6	86	-	-	PD5	I/O	FT	PD5	USART2_TX /FSMC_NWE	
120	F7	-	-	-	V <sub>SS_10</sub>	S		V <sub>SS_10</sub>		
121	G7	-	-	-	V <sub>DD_10</sub>	S		V <sub>DD_10</sub>		
122	B6	87	-	-	PD6	I/O	FT	PD6	USART2_RX /FSMC_NWAIT	
123	A5	88	-	-	PD7	I/O	FT	PD7	TIM9_CH2/USART2_CK/ FSMC_NE1	
124	D9	-	-	-	PG9	I/O	FT	PG9	FSMC_NE2	
125	D8	-	-	-	PG10	I/O	FT	PG10	FSMC_NE3	
126	-	-	-	-	PG11	I/O	FT	PG11		
127	D7	-	-	-	PG12	I/O	FT	PG12	FSMC_NE4	
128	C7	-	-	-	PG13	I/O	FT	PG13	FSMC_A24	
129	C6	-	-	-	PG14	I/O	FT	PG14	FSMC_A25	

Table 7. STM32L162xD pin definitions (continued)

Pins					Pin name	Type <sup>(1)</sup>	I / O Level <sup>(2)</sup>	Main function <sup>(3)</sup> (after reset)	Pin functions	
LQFP144	UFBGA132	LQFP100	LQFP64	WLCSP64					Alternate functions	Additional functions
130	-	-	-	-	V <sub>SS_11</sub>	S		V <sub>SS_11</sub>		
131	-	-	-	-	V <sub>DD_11</sub>	S		V <sub>DD_11</sub>		
132	-	-	-	-	PG15	I/O	FT	PG15		
133	A8	89	55	A4	PB3	I/O	FT	JTDO	TIM2_CH2/SPI1_SCK/ SPI3_SCK/ I2S3_CK/ LCD_SEG7/JTDO	COMP2_INM
134	A7	90	56	B4	PB4	I/O	FT	NJTRST	TIM3_CH1/SPI1_MISO/ SPI3_MISO/ LCD_SEG8/NJTRST	COMP2_INP
135	C5	91	57	A5	PB5	I/O	FT	PB5	TIM3_CH2/I2C1_SMBA/ SPI1_MOSI/ SPI3_MOSI/ I2S3_SD/LCD_SEG9	COMP2_INP
136	B5	92	58	B5	PB6	I/O	FT	PB6	TIM4_CH1/I2C1_SCL/ USART1_TX	COMP2_INP
137	B4	93	59	C5	PB7	I/O	FT	PB7	TIM4_CH2/I2C1_SDA/ USART1_RX/ FSMC_NADV	COMP2_INP /PVD_IN
138	A4	94	60	A6	BOOT0	I		BOOT0		
139	A3	95	61	D5	PB8	I/O	FT	PB8	TIM4_CH3/TIM10_CH1/ I2C1_SCL/ LCD_SEG16/SDIO_D4	
140	B3	96	62	B6	PB9	I/O	FT	PB9	TIM4_CH4/TIM11_CH1/ I2C1_SDA/ LCD_COM3/ SDIO_D5	
141	C3	97	-	-	PE0	I/O	FT	PE0	TIM4_ETR/TIM10_CH1/ LCD_SEG36 /FSMC_NBL0	
142	A2	98	-	-	PE1	I/O	FT	PE1	TIM11_CH1/LCD_SEG37 /FSMC_NBL1	
143	D3	99	63	A7	V <sub>SS_3</sub>	S		V <sub>SS_3</sub>		
144	C4	100	64	A8	V <sub>DD_3</sub>	S		V <sub>DD_3</sub>		

1. I = input, O = output, S = supply.

2. FT = 5 V tolerant.

3. Function availability depends on the chosen device.

4. The PC14 and PC15 I/Os are only configured as OSC32\_IN/OSC32\_OUT when the LSE oscillator is ON (by setting the LSEON bit in the RCC\_CSR register). The LSE oscillator pins OSC32\_IN/OSC32\_OUT can be used as general-purpose PH0/PH1 I/Os, respectively, when the LSE oscillator is off (after reset, the LSE oscillator is off). The LSE has priority over the GPIO function. For more details, refer to Using the OSC32\_IN/OSC32\_OUT pins as GPIO PC14/PC15 port pins section in the STM32L151xx, STM32L152xx and STM32L162xx reference manual (RM0038).
5. The PH0 and PH1 I/Os are only configured as OSC\_IN/OSC\_OUT when the HSE oscillator is ON (by setting the HSEON bit in the RCC\_CR register). The HSE oscillator pins OSC\_IN/OSC\_OUT can be used as general-purpose PH0/PH1 I/Os, respectively, when the HSE oscillator is off ( after reset, the HSE oscillator is off ). The HSE has priority over the GPIO function.



## Alternate functions

Table 8. Alternate function input/output

Port name	Digital alternate function number														
	AFIO0	AFIO1	AFIO2	AFIO3	AFIO4	AFIO5	AFIO6	AFIO7	AFIO8	..	AFIO11	AFIO12	..	AFIO14	AFIO15
	Alternate function														
	SYSTEM	TIM2	TIM3/4/5	TIM9/ 10/11	I2C1/2	SPI1/2	SPI3	USART1/2/3	UART4/5		LCD	FSMC/ SDIO		CPRI	SYSTEM
BOOT0	BOOT0														EVENT OUT
NRST	NRST														
PA0-WKUP1		TIM2_CH1_ETR	TIM5_CH1					USART2_CTS						TIMx_IC1	EVENT OUT
PA1		TIM2_CH2	TIM5_CH2					USART2_RTS		SEG0				TIMx_IC2	EVENT OUT
PA2		TIM2_CH3	TIM5_CH3	TIM9_CH1				USART2_TX		SEG1				TIMx_IC3	EVENT OUT
PA3		TIM2_CH4	TIM5_CH4	TIM9_CH2				USART2_RX		SEG2				TIMx_IC4	EVENT OUT
PA4						SPI1_NSS	SPI3_NSS I2S3_WS	USART2_CK						TIMx_IC1	EVENT OUT
PA5		TIM2_CH1_ETR				SPI1_SCK								TIMx_IC2	EVENT OUT
PA6			TIM3_CH1	TIM10_CH1		SPI1_MISO					SEG3			TIMx_IC3	EVENT OUT
PA7			TIM3_CH2	TIM11_CH1		SPI1_MOSI					SEG4			TIMx_IC4	EVENT OUT
PA8	MCO							USART1_CK			COM0			TIMx_IC1	EVENT OUT
PA9								USART1_TX			COM1			TIMx_IC2	EVENT OUT
PA10								USART1_RX			COM2			TIMx_IC3	EVENT OUT
PA11						SPI1_MISO		USART1_CTS						TIMx_IC4	EVENT OUT

**Table 8. Alternate function input/output (continued)**

Port name	Digital alternate function number														
	AFIO0	AFIO1	AFIO2	AFIO3	AFIO4	AFIO5	AFIO6	AFIO7	AFIO8	..	AFIO11	AFIO12	..	AFIO14	AFIO15
	Alternate function														
	SYSTEM	TIM2	TIM3/4/5	TIM9/ 10/11	I2C1/2	SPI1/2	SPI3	USART1/2/3	UART4/5	LCD	FSMC/ SDIO	CPRI	SYSTEM		
PA12						SPI1_MOSI		USART1_RTS					TIMx_IC1	EVENT OUT	
PA13	JTMS-SWDIO												TIMx_IC2	EVENT OUT	
PA14	JTCK-SWCLK												TIMx_IC3	EVENT OUT	
PA15	JTDI	TIM2_CH1_ETR				SPI1_NSS	SPI3_NSS I2S3_WS			SEG17			TIMx_IC4	EVENT OUT	
PB0			TIM3_CH3							SEG5				EVENT OUT	
PB1			TIM3_CH4							SEG6				EVENT OUT	
PB2	BOOT1													EVENT OUT	
PB3	JTDO	TIM2_CH2				SPI1_SCK	SPI3_SCK I2S3_CK			SEG7				EVENT OUT	
PB4	NJTRST		TIM3_CH1			SPI1_MISO	SPI3_MISO			SEG8				EVENT OUT	
PB5			TIM3_CH2		I2C1_ SMBA	SPI1_MOSI	SPI3_MOSI I2S3_SD			SEG9				EVENT OUT	
PB6			TIM4_CH1		I2C1_SCL			USART1_TX						EVENT OUT	
PB7			TIM4_CH2		I2C1_SDA			USART1_RX			NADV			EVENT OUT	
PB8			TIM4_CH3	TIM10_CH1	I2C1_SCL					SEG16	SDIO_D4			EVENT OUT	
PB9			TIM4_CH4	TIM11_CH1	I2C1_SDA					COM3	SDIO_D5			EVENT OUT	
PB10		TIM2_CH3			I2C2_SCL			USART3_TX		SEG10				EVENT OUT	



Table 8. Alternate function input/output (continued)

Port name	Digital alternate function number														
	AFIO0	AFIO1	AFIO2	AFIO3	AFIO4	AFIO5	AFIO6	AFIO7	AFIO8	..	AFIO11	AFIO12	..	AFIO14	AFIO15
	Alternate function														
	SYSTEM	TIM2	TIM3/4/5	TIM9/ 10/11	I2C1/2	SPI1/2	SPI3	USART1/2/3	UART4/5	LCD	FSMC/ SDIO	CPRI	SYSTEM		
PB11		TIM2_CH4			I2C2_SDA			USART3_RX		SEG11					EVENT OUT
PB12				TIM10_CH1	I2C2_SMBAL	SPI2_NSS I2S2_WS		USART3_CK		SEG12					EVENT OUT
PB13				TIM9_CH1		SPI2_SCK I2S2_CK		USART3_CTS		SEG13					EVENT OUT
PB14				TIM9_CH2		SPI2_MISO		USART3_RTS		SEG14					EVENT OUT
PB15				TIM11_CH1		SPI2_MOSI I2S2_SD				SEG15					EVENT OUT
PC0										SEG18		TIMx_IC1			EVENT OUT
PC1										SEG19		TIMx_IC2			EVENT OUT
PC2										SEG20		TIMx_IC3			EVENT OUT
PC3										SEG21		TIMx_IC4			EVENT OUT
PC4										SEG22		TIMx_IC1			EVENT OUT
PC5										SEG23		TIMx_IC2			EVENT OUT
PC6				TIM3_CH1		I2S2_MCK				SEG24	SDIO_D6	TIMx_IC3			EVENT OUT
PC7				TIM3_CH2			I2S3_MCK			SEG25	SDIO_D7	TIMx_IC4			EVENT OUT
PC8				TIM3_CH3						SEG26	SDIO_D0	TIMx_IC1			EVENT OUT
PC9				TIM3_CH4						SEG27	SDIO_D1	TIMx_IC2			EVENT OUT

Table 8. Alternate function input/output (continued)

Port name	Digital alternate function number														
	AFIO0	AFIO1	AFIO2	AFIO3	AFIO4	AFIO5	AFIO6	AFIO7	AFIO8	..	AFIO11	AFIO12	..	AFIO14	AFIO15
	Alternate function														
	SYSTEM	TIM2	TIM3/4/5	TIM9/ 10/11	I2C1/2	SPI1/2	SPI3	USART1/2/3	UART4/5	LCD	FSMC/ SDIO	CPRI	SYSTEM		
PC10							SPI3_SCK I2S3_CK	USART3_TX	UART4_TX	COM4/ SEG28/ SEG40	SDIO_D2	TIMx_IC3	EVENT OUT		
PC11							SPI3_MISO	USART3_RX	UART4_RX	COM5/ SEG29 /SEG41	SDIO_D3	TIMx_IC4	EVENT OUT		
PC12							SPI3_MOSI I2S3_SD	USART3_CK	UART5_TX	COM6/ SEG30/ SEG42	SDIO_CK	TIMx_IC1	EVENT OUT		
PC13-WKUP2												TIMx_IC2	EVENT OUT		
PC14 OSC32_IN												TIMx_IC3	EVENT OUT		
PC15 OSC32_OUT												TIMx_IC4	EVENT OUT		
PD0				TIM9_CH1		SPI2_NSS I2S2_WS					D2 /DA2	TIMx_IC1	EVENT OUT		
PD1						SPI2_SCK I2S2_CK					D3 /DA3	TIMx_IC2	EVENT OUT		
PD2			TIM3_ETR						UART5_RX	COM7/ SEG31/ SEG43	SDIO_ CMD	TIMx_IC3	EVENT OUT		
PD3						SPI2_MISO		USART2_CTS			CLK	TIMx_IC4	EVENT OUT		
PD4						SPI2_MOSI I2S2_SD		USART2_RTS			NOE	TIMx_IC1	EVENT OUT		
PD5								USART2_TX			NWE	TIMx_IC2	EVENT OUT		
PD6								USART2_RX			NWAIT	TIMx_IC3	EVENT OUT		
PD7				TIM9_CH2				USART2_CK			NE1	TIMx_IC4	EVENT OUT		



Table 8. Alternate function input/output (continued)

Port name	Digital alternate function number														
	AFIO0	AFIO1	AFIO2	AFIO3	AFIO4	AFIO5	AFIO6	AFIO7	AFIO8	..	AFIO11	AFIO12	..	AFIO14	AFIO15
	Alternate function														
	SYSTEM	TIM2	TIM3/4/5	TIM9/ 10/11	I2C1/2	SPI1/2	SPI3	USART1/2/3	UART4/5	LCD	FSMC/ SDIO	CPRI	SYSTEM		
PD8								USART3_TX		SEG28	D13/DA13	TIMx_IC1	EVENT OUT		
PD9								USART3_RX		SEG29	D14/DA14	TIMx_IC2	EVENT OUT		
PD10								USART3_CK		SEG30	D15/DA15	TIMx_IC3	EVENT OUT		
PD11								USART3_CTS		SEG31	A16	TIMx_IC4	EVENT OUT		
PD12			TIM4_CH1					USART3_RTS		SEG32	A17	TIMx_IC1	EVENT OUT		
PD13			TIM4_CH2							SEG33	A18	TIMx_IC2	EVENT OUT		
PD14			TIM4_CH3							SEG34	D0/DA0	TIMx_IC3	EVENT OUT		
PD15			TIM4_CH4							SEG35	D1/DA1	TIMx_IC4	EVENT OUT		
PE0			TIM4_ETR	TIM10_CH1						SEG36	NBL0	TIMx_IC1	EVENT OUT		
PE1				TIM11_CH1						SEG37	NBL1	TIMx_IC2	EVENT OUT		
PE2	TRACECK		TIM3_ETR							SEG 38	A23	TIMx_IC3	EVENT OUT		
PE3	TRACED0		TIM3_CH1							SEG 39	A19	TIMx_IC4	EVENT OUT		
PE4	TRACED1		TIM3_CH2								A20	TIMx_IC1	EVENT OUT		
PE5	TRACED2			TIM9_CH1							A21	TIMx_IC2	EVENT OUT		
PE6-WKUP3	TRACED3			TIM9_CH2								TIMx_IC3	EVENT OUT		

**Table 8. Alternate function input/output (continued)**

Port name	Digital alternate function number														
	AFIO0	AFIO1	AFIO2	AFIO3	AFIO4	AFIO5	AFIO6	AFIO7	AFIO8	..	AFIO11	AFIO12	..	AFIO14	AFIO15
	Alternate function														
	SYSTEM	TIM2	TIM3/4/5	TIM9/ 10/11	I2C1/2	SPI1/2	SPI3	USART1/2/3	UART4/5	LCD	FSMC/ SDIO	CPRI	SYSTEM		
PE7											D4/DA4	TIMx_IC4	EVENT OUT		
PE8											D5/DA5	TIMx_IC1	EVENT OUT		
PE9		TIM2_CH1_ETR									D6/DA6	TIMx_IC2	EVENT OUT		
PE10		TIM2_CH2									D7/DA7	TIMx_IC3	EVENT OUT		
PE11		TIM2_CH3									D8/DA8	TIMx_IC4	EVENT OUT		
PE12		TIM2_CH4				SPI1_NSS					D9/DA9	TIMx_IC1	EVENT OUT		
PE13						SPI1_SCK					D10/DA10	TIMx_IC2	EVENT OUT		
PE14						SPI1_MISO					D11/DA11	TIMx_IC3	EVENT OUT		
PE15						SPI1_MOSI					D12/DA12	TIMx_IC4	EVENT OUT		
PF0											A0		EVENT OUT		
PF1											A1		EVENT OUT		
PF2											A2		EVENT OUT		
PF3											A3		EVENT OUT		
PF4											A4		EVENT OUT		
PF5											A5		EVENT OUT		



Table 8. Alternate function input/output (continued)

Port name	Digital alternate function number														
	AFIO0	AFIO1	AFIO2	AFIO3	AFIO4	AFIO5	AFIO6	AFIO7	AFIO8	..	AFIO11	AFIO12	..	AFIO14	AFIO15
	Alternate function														
	SYSTEM	TIM2	TIM3/4/5	TIM9/ 10/11	I2C1/2	SPI1/2	SPI3	USART1/2/3	UART4/5	LCD	FSMC/ SDIO	CPRI	SYSTEM		
PF6			TIM5_ETR												EVENT OUT
PF7			TIM5_CH2												EVENT OUT
PF8			TIM5_CH3												EVENT OUT
PF9			TIM5_CH4												EVENT OUT
PF10															EVENT OUT
PF11															EVENT OUT
PF12											A6				EVENT OUT
PF13											A7				EVENT OUT
PF14											A8				EVENT OUT
PF15											A9				EVENT OUT
PG0											A10				EVENT OUT
PG1											A11				EVENT OUT
PG2											A12				EVENT OUT
PG3											A13				EVENT OUT
PG4											A14				EVENT OUT



**Table 8. Alternate function input/output (continued)**

Port name	Digital alternate function number														
	AFIO0	AFIO1	AFIO2	AFIO3	AFIO4	AFIO5	AFIO6	AFIO7	AFIO8	..	AFIO11	AFIO12	..	AFIO14	AFIO15
	Alternate function														
	SYSTEM	TIM2	TIM3/4/5	TIM9/ 10/11	I2C1/2	SPI1/2	SPI3	USART1/2/3	UART4/5	LCD	FSMC/ SDIO	CPRI	SYSTEM		
PG5											A15				EVENT OUT
PG6															EVENT OUT
PG7															EVENT OUT
PG8															EVENT OUT
PG9											NE2				EVENT OUT
PG10											NE3				EVENT OUT
PG11															EVENT OUT
PG12											NE4				EVENT OUT
PG13											A24				EVENT OUT
PG14											A25				EVENT OUT
PG15															EVENT OUT
PH0OSC_IN															
PH1OSC_OUT															
PH2											A22				



## 6 Electrical characteristics

### 6.1 Parameter conditions

Unless otherwise specified, all voltages are referenced to  $V_{SS}$ .

#### 6.1.1 Minimum and maximum values

Unless otherwise specified the minimum and maximum values are guaranteed in the worst conditions of ambient temperature, supply voltage and frequencies by tests in production on 100% of the devices with an ambient temperature at  $T_A = 25\text{ °C}$  and  $T_A = T_{Amax}$  (given by the selected temperature range).

Data based on characterization results, design simulation and/or technology characteristics are indicated in the table footnotes and are not tested in production. Based on characterization, the minimum and maximum values refer to sample tests and represent the mean value plus or minus three times the standard deviation (mean  $\pm 3\sigma$ ).

#### 6.1.2 Typical values

Unless otherwise specified, typical data are based on  $T_A = 25\text{ °C}$ ,  $V_{DD} = 3.6\text{ V}$  (for the  $1.65\text{ V} \leq V_{DD} \leq 3.6\text{ V}$  voltage range). They are given only as design guidelines and are not tested.

Typical ADC accuracy values are determined by characterization of a batch of samples from a standard diffusion lot over the full temperature range, where 95% of the devices have an error less than or equal to the value indicated (mean  $\pm 2\sigma$ ).

#### 6.1.3 Typical curves

Unless otherwise specified, all typical curves are given only as design guidelines and are not tested.

#### 6.1.4 Loading capacitor

The loading conditions used for pin parameter measurement are shown in [Figure 9](#).

#### 6.1.5 Pin input voltage

The input voltage measurement on a pin of the device is described in [Figure 10](#).

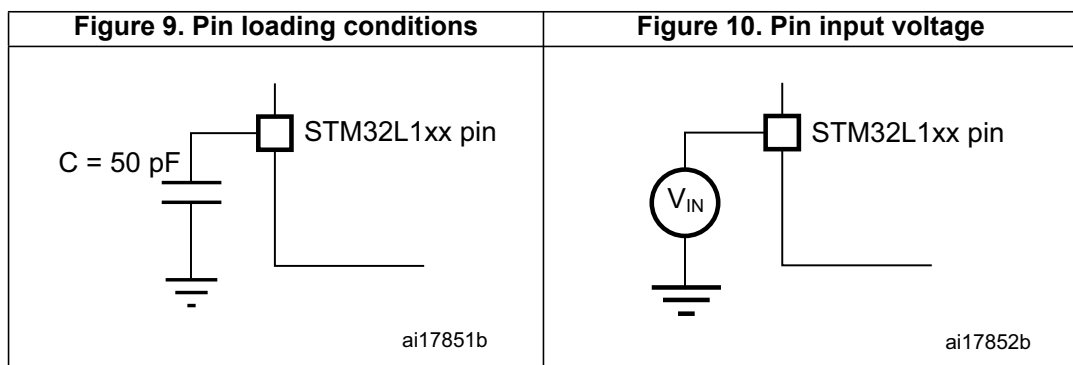

6.1.6 Power supply scheme

Figure 11. Power supply scheme

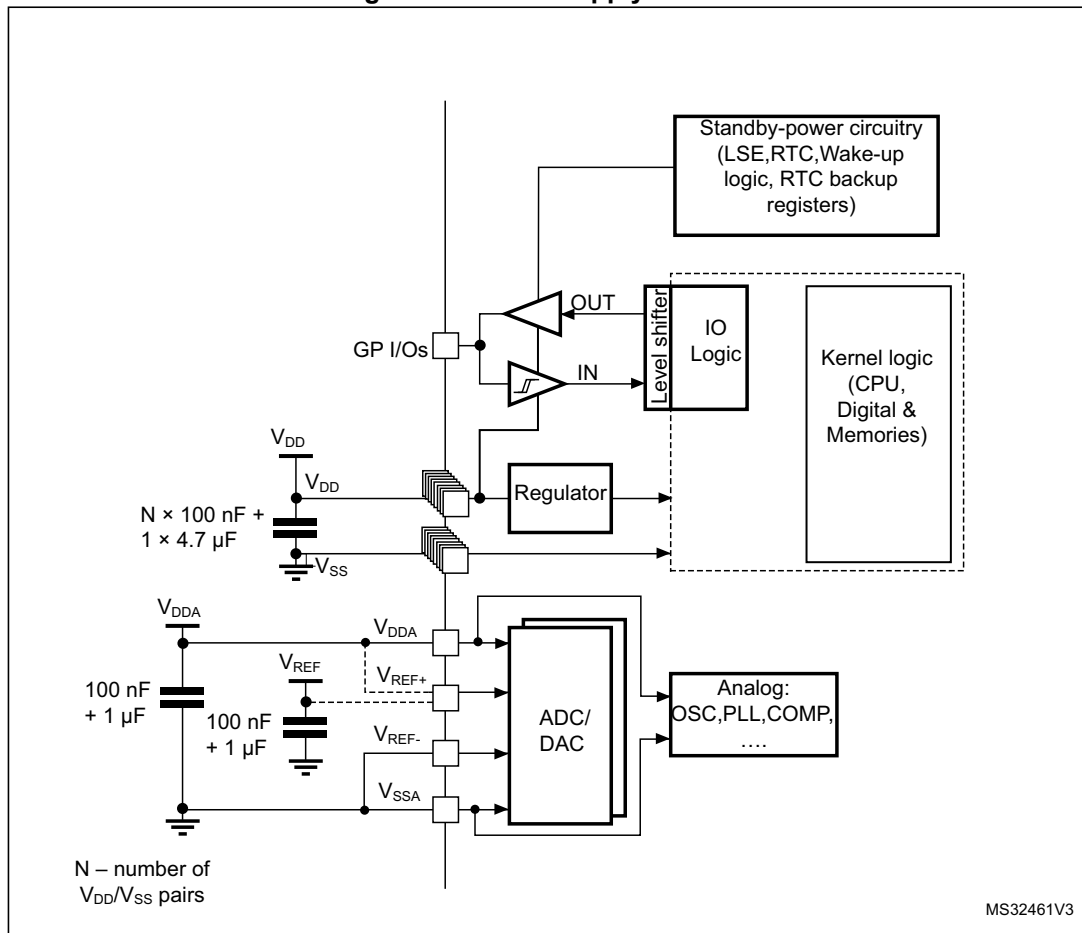

### 6.1.7 Optional LCD power supply scheme

Figure 12. Optional LCD power supply scheme

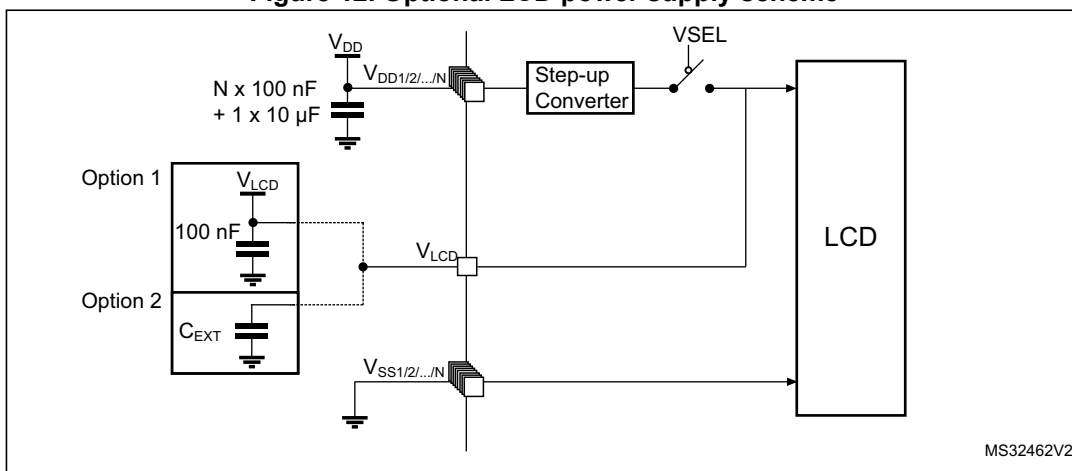

1. Option 1: LCD power supply is provided by a dedicated VLCD supply source, VSEL switch is open.
2. Option 2: LCD power supply is provided by the internal step-up converter, VSEL switch is closed, an external capacitance is needed for correct behavior of this converter.

### 6.1.8 Current consumption measurement

Figure 13. Current consumption measurement scheme

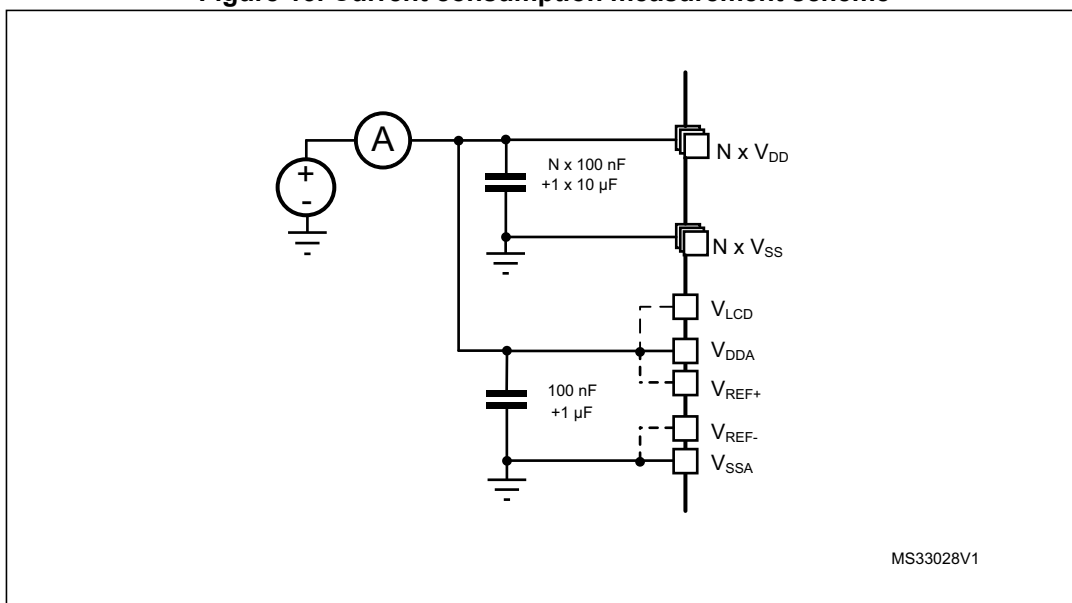

## 6.2 Absolute maximum ratings

Stresses above the absolute maximum ratings listed in [Table 9: Voltage characteristics](#), [Table 10: Current characteristics](#), and [Table 11: Thermal characteristics](#) may cause permanent damage to the device. These are stress ratings only and functional operation of the device at these conditions is not implied. Exposure to maximum rating conditions for extended periods may affect device reliability.

**Table 9. Voltage characteristics**

Symbol	Ratings	Min	Max	Unit
$V_{DD}-V_{SS}$	External main supply voltage (including $V_{DDA}$ and $V_{DD}$ ) <sup>(1)</sup>	-0.3	4.0	V
$V_{IN}^{(2)}$	Input voltage on five-volt tolerant pin	$V_{SS} - 0.3$	$V_{DD} + 4.0$	
	Input voltage on any other pin	$V_{SS} - 0.3$	4.0	
$ \Delta V_{DDx} $	Variations between different $V_{DD}$ power pins	-	50	mV
$ V_{SSx} - V_{SS} $	Variations between all different ground pins	-	50	
$V_{REF+} - V_{DDA}$	Allowed voltage difference for $V_{REF+} > V_{DDA}$	-	0.4	V
$V_{ESD(HBM)}$	Electrostatic discharge voltage (human body model)	see <a href="#">Section 6.3.12</a>		

- All main power ( $V_{DD}$ ,  $V_{DDA}$ ) and ground ( $V_{SS}$ ,  $V_{SSA}$ ) pins must always be connected to the external power supply, in the permitted range.
- $V_{IN}$  maximum must always be respected. Refer to [Table 10](#) for maximum allowed injected current values.

**Table 10. Current characteristics**

Symbol	Ratings	Max.	Unit
$I_{VDD(\Sigma)}$	Total current into sum of all $V_{DD\_x}$ power lines (source) <sup>(1)</sup>	100	mA
$I_{VSS(\Sigma)}^{(2)}$	Total current out of sum of all $V_{SS\_x}$ ground lines (sink) <sup>(1)</sup>	100	
$I_{VDD(PIN)}$	Maximum current into each $V_{DD\_x}$ power pin (source) <sup>(1)</sup>	70	
$I_{VSS(PIN)}$	Maximum current out of each $V_{SS\_x}$ ground pin (sink) <sup>(1)</sup>	-70	
$I_{IO}$	Output current sunk by any I/O and control pin	25	
	Output current sourced by any I/O and control pin	- 25	
$\Sigma I_{IO(PIN)}$	Total output current sunk by sum of all IOs and control pins <sup>(2)</sup>	60	
	Total output current sourced by sum of all IOs and control pins <sup>(2)</sup>	-60	
$I_{INJ(PIN)}^{(3)}$	Injected current on five-volt tolerant I/O <sup>(4)</sup> , RST and B pins	-5/+0	
	Injected current on any other pin <sup>(5)</sup>	$\pm 5$	
$\Sigma I_{INJ(PIN)}$	Total injected current (sum of all I/O and control pins) <sup>(6)</sup>	$\pm 25$	

- All main power ( $V_{DD}$ ,  $V_{DDA}$ ) and ground ( $V_{SS}$ ,  $V_{SSA}$ ) pins must always be connected to the external power supply, in the permitted range.
- This current consumption must be correctly distributed over all I/Os and control pins. The total output current must not be sunk/sourced between two consecutive power supply pins referring to high pin count LQFP packages.
- Negative injection disturbs the analog performance of the device. See note in [Section 6.3.19](#).
- Positive current injection is not possible on these I/Os. A negative injection is induced by  $V_{IN} < V_{SS}$ .  $I_{INJ(PIN)}$  must never be exceeded. Refer to [Table 9](#) for maximum allowed input voltage values.

5. A positive injection is induced by  $V_{IN} > V_{DD}$  while a negative injection is induced by  $V_{IN} < V_{SS}$ .  $I_{INJ(PIN)}$  must never be exceeded. Refer to [Table 9: Voltage characteristics](#) for the maximum allowed input voltage values.
6. When several inputs are submitted to a current injection, the maximum  $\Sigma I_{INJ(PIN)}$  is the absolute sum of the positive and negative injected currents (instantaneous values).

**Table 11. Thermal characteristics**

Symbol	Ratings	Value	Unit
$T_{STG}$	Storage temperature range	-65 to +150	°C
$T_J$	Maximum junction temperature	150	°C

## 6.3 Operating conditions

### 6.3.1 General operating conditions

**Table 12. General operating conditions**

Symbol	Parameter	Conditions	Min	Max	Unit
$f_{HCLK}$	Internal AHB clock frequency	-	0	32	MHz
$f_{PCLK1}$	Internal APB1 clock frequency	-	0	32	
$f_{PCLK2}$	Internal APB2 clock frequency	-	0	32	
$V_{DD}$	Standard operating voltage	BOR detector disabled	1.65	3.6	V
		BOR detector enabled, at power on	1.8	3.6	
		BOR detector disabled, after power on	1.65	3.6	
$V_{DDA}^{(1)}$	Analog operating voltage (ADC and DAC not used)	Must be the same voltage as $V_{DD}^{(2)}$	1.65	3.6	V
	Analog operating voltage (ADC or DAC used)		1.8	3.6	
$V_{IN}$	I/O input voltage	FT pins; $2.0\text{ V} \leq V_{DD}$	-0.3	$5.5^{(3)}$	V
		FT pins; $V_{DD} < 2.0\text{ V}$	-0.3	$5.25^{(3)}$	
		BOOT0 pin	0	5.5	
		Any other pin	-0.3	$V_{DD}+0.3$	
$P_D$	Power dissipation at $T_A = 85\text{ °C}$ for suffix 6 or $T_A = 105\text{ °C}$ for suffix 7 <sup>(4)</sup>	LQFP144 package		500	mW
		LQFP100 package		465	
		LQFP64 package		435	
		UFBGA132		333	
		WLCSP64 package		435	
$T_A$	Ambient temperature for 6 suffix version	Maximum power dissipation <sup>(5)</sup>	-40	85	°C
	Ambient temperature for 7 suffix version	Maximum power dissipation	-40	105	

Table 12. General operating conditions (continued)

Symbol	Parameter	Conditions	Min	Max	Unit
T <sub>J</sub>	Junction temperature range	6 suffix version	-40	105	°C
		7 suffix version	-40	110	

1. When the ADC is used, refer to [Table 63: ADC characteristics](#).
2. It is recommended to power V<sub>DD</sub> and V<sub>DDA</sub> from the same source. A maximum difference of 300 mV between V<sub>DD</sub> and V<sub>DDA</sub> can be tolerated during power-up and operation.
3. To sustain a voltage higher than VDD+0.3V, the internal pull-up/pull-down resistors must be disabled
4. If T<sub>A</sub> is lower, higher P<sub>D</sub> values are allowed as long as T<sub>J</sub> does not exceed T<sub>J</sub> max (see [Table 78: Thermal characteristics on page 145](#)).
5. In low-power dissipation state, T<sub>A</sub> can be extended to -40°C to 105°C temperature range as long as T<sub>J</sub> does not exceed T<sub>J</sub> max (see [Table 78: Thermal characteristics on page 145](#)).

### 6.3.2 Embedded reset and power control block characteristics

The parameters given in the following table are derived from the tests performed under the conditions summarized in [Table 12](#).

Table 13. Embedded reset and power control block characteristics

Symbol	Parameter	Conditions	Min	Typ	Max	Unit
t <sub>VDD</sub> <sup>(1)</sup>	V <sub>DD</sub> rise time rate	BOR detector enabled	0	-	∞	μs/V
		BOR detector disabled	0	-	1000	
	V <sub>DD</sub> fall time rate	BOR detector enabled	20	-	∞	
		BOR detector disabled	0	-	1000	
T <sub>RSTTEMPO</sub> <sup>(1)</sup>	Reset temporization	V <sub>DD</sub> rising, BOR enabled	-	2	3.3	ms
		V <sub>DD</sub> rising, BOR disabled <sup>(2)</sup>	0.4	0.7	1.6	
V <sub>POR/PDR</sub>	Power on/power down reset threshold	Falling edge	1	1.5	1.65	V
		Rising edge	1.3	1.5	1.65	
V <sub>BOR0</sub>	Brown-out reset threshold 0	Falling edge	1.67	1.7	1.74	
		Rising edge	1.69	1.76	1.8	
V <sub>BOR1</sub>	Brown-out reset threshold 1	Falling edge	1.87	1.93	1.97	
		Rising edge	1.96	2.03	2.07	
V <sub>BOR2</sub>	Brown-out reset threshold 2	Falling edge	2.22	2.30	2.35	
		Rising edge	2.31	2.41	2.44	

**Table 13. Embedded reset and power control block characteristics (continued)**

Symbol	Parameter	Conditions	Min	Typ	Max	Unit
V <sub>BOR3</sub>	Brown-out reset threshold 3	Falling edge	2.45	2.55	2.6	V
		Rising edge	2.54	2.66	2.7	
V <sub>BOR4</sub>	Brown-out reset threshold 4	Falling edge	2.68	2.8	2.85	
		Rising edge	2.78	2.9	2.95	
V <sub>PVD0</sub>	Programmable voltage detector threshold 0	Falling edge	1.8	1.85	1.88	
		Rising edge	1.88	1.94	1.99	
V <sub>PVD1</sub>	PVD threshold 1	Falling edge	1.98	2.04	2.09	
		Rising edge	2.08	2.14	2.18	
V <sub>PVD2</sub>	PVD threshold 2	Falling edge	2.20	2.24	2.28	
		Rising edge	2.28	2.34	2.38	
V <sub>PVD3</sub>	PVD threshold 3	Falling edge	2.39	2.44	2.48	
		Rising edge	2.47	2.54	2.58	
V <sub>PVD4</sub>	PVD threshold 4	Falling edge	2.57	2.64	2.69	
		Rising edge	2.68	2.74	2.79	
V <sub>PVD5</sub>	PVD threshold 5	Falling edge	2.77	2.83	2.88	
		Rising edge	2.87	2.94	2.99	
V <sub>PVD6</sub>	PVD threshold 6	Falling edge	2.97	3.05	3.09	
		Rising edge	3.08	3.15	3.20	
V <sub>hyst</sub>	Hysteresis voltage	BOR0 threshold	-	40	-	mV
		All BOR and PVD thresholds excepting BOR0	-	100	-	

1. Guaranteed by characterization results, not tested in production.
2. Valid for device version without BOR at power up. Please see option "D" in Ordering information scheme for more details.

### 6.3.3 Embedded internal reference voltage

The parameters given in [Table 15](#) are based on characterization results, unless otherwise specified.

**Table 14. Embedded internal reference voltage calibration values**

Calibration value name	Description	Memory address
VREFINT_CAL	Raw data acquired at temperature of 30 °C ±5 °C V <sub>DDA</sub> = 3 V ±10 mV	0x1FF8 00F8 - 0x1FF8 00F9

**Table 15. Embedded internal reference voltage**

Symbol	Parameter	Conditions	Min	Typ	Max	Unit
V <sub>REFINT out</sub> <sup>(1)</sup>	Internal reference voltage	-40 °C < T <sub>J</sub> < +110 °C	1.202	1.224	1.242	V
I <sub>REFINT</sub>	Internal reference current consumption	-	-	1.4	2.3	µA
T <sub>VREFINT</sub>	Internal reference startup time	-	-	2	3	ms
V <sub>VREF_MEAS</sub>	V <sub>DDA</sub> and V <sub>REF+</sub> voltage during V <sub>REFINT</sub> factory measure	-	2.99	3	3.01	V
A <sub>VREF_MEAS</sub>	Accuracy of factory-measured V <sub>REF</sub> value <sup>(2)</sup>	Including uncertainties due to ADC and V <sub>DDA</sub> /V <sub>REF+</sub> values	-	-	±5	mV
T <sub>Coef</sub> <sup>(3)</sup>	Temperature coefficient	-40 °C < T <sub>J</sub> < +110 °C	-	20	50	ppm/°C
		0 °C < T <sub>J</sub> < +50 °C	-	-	20	
A <sub>Coef</sub> <sup>(3)</sup>	Long-term stability	1000 hours, T = 25 °C	-	-	1000	ppm
V <sub>DDCoef</sub> <sup>(3)</sup>	Voltage coefficient	3.0 V < V <sub>DDA</sub> < 3.6 V	-	-	2000	ppm/V
T <sub>S_vrefint</sub> <sup>(3)</sup>	ADC sampling time when reading the internal reference voltage	-	4	-	-	µs
T <sub>ADC_BUF</sub> <sup>(3) (4)</sup>	Startup time of reference voltage buffer for ADC	-	-	-	10	µs
I <sub>BUF_ADC</sub> <sup>(3)</sup>	Consumption of reference voltage buffer for ADC	-	-	13.5	25	µA
I <sub>VREF_OUT</sub> <sup>(3)</sup>	VREF_OUT output current <sup>(5)</sup>	-	-	-	1	µA
C <sub>VREF_OUT</sub> <sup>(3)</sup>	VREF_OUT output load	-	-	-	50	pF
I <sub>LPBUF</sub> <sup>(3)</sup>	Consumption of reference voltage buffer for VREF_OUT and COMP	-	-	730	1200	nA
V <sub>REFINT_DIV1</sub> <sup>(3)</sup>	1/4 reference voltage	-	24	25	26	% V <sub>REFINT</sub>
V <sub>REFINT_DIV2</sub> <sup>(3)</sup>	1/2 reference voltage	-	49	50	51	
V <sub>REFINT_DIV3</sub> <sup>(3)</sup>	3/4 reference voltage	-	74	75	76	

1. Guaranteed by test in production.

2. The internal V<sub>REF</sub> value is individually measured in production and stored in dedicated EEPROM bytes.

3. Guaranteed by design, not tested in production.

4. Shortest sampling time can be determined in the application by multiple iterations.

5. To guarantee less than 1% VREF\_OUT deviation.

### 6.3.4 Supply current characteristics

The current consumption is a function of several parameters and factors such as the operating voltage, temperature, I/O pin loading, device software configuration, operating frequencies, I/O pin switching rate, program location in memory and executed binary code. The current consumption is measured as described in [Figure 13: Current consumption measurement scheme](#).

All Run-mode current consumption measurements given in this section are performed with a reduced code that gives a consumption equivalent to the Dhrystone 2.1 code, unless otherwise specified. The current consumption values are derived from tests performed under ambient temperature  $T_A = 25\text{ °C}$  and  $V_{DD}$  supply voltage conditions summarized in [Table 12: General operating conditions](#), unless otherwise specified.

The MCU is placed under the following conditions:

- All I/O pins are configured in analog input mode
- All peripherals are disabled except when explicitly mentioned.
- The Flash memory access time, 64-bit access and prefetch is adjusted depending on  $f_{HCLK}$  frequency and voltage range to provide the best CPU performance.
- When the peripherals are enabled  $f_{APB1} = f_{APB2} = f_{AHB}$ .
- When PLL is ON, the PLL inputs are equal to HSI = 16 MHz (if internal clock is used) or HSE = 16 MHz (if HSE bypass mode is used).
- The HSE user clock applied to OSCI\_IN input follows the characteristic specified in [Table 25: High-speed external user clock characteristics](#).
- For maximum current consumption  $V_{DD} = V_{DDA} = 3.6\text{ V}$  is applied to all supply pins.
- For typical current consumption  $V_{DD} = V_{DDA} = 3.0\text{ V}$  is applied to all supply pins if not specified otherwise.

**Table 16. Current consumption in Run mode, code with data processing running from Flash**

Symbol	Parameter	Conditions	f <sub>HCLK</sub> [MHz]	Typ	Max (1)	Unit		
I <sub>DD</sub> (Run from Flash)	Supply current in Run mode code executed from Flash	f <sub>HSE</sub> = f <sub>HCLK</sub> up to 16MHz, included f <sub>HSE</sub> = f <sub>HCLK</sub> /2 above 16 MHz (PLL ON) <sup>(2)</sup>	Range3, V <sub>CORE</sub> =1.2 V VOS[1:0]=11	1	290	500	μA	
				2	505	750		
				4	955	1200		
				Range2, V <sub>CORE</sub> =1.5 V VOS[1:0]=10	4	1.15	1.6	mA
				8	2.3	2.9		
				16	4.25	5.2		
			Range1, V <sub>CORE</sub> =1.8 V VOS[1:0]=01	8	2.65	3.5		
			16	5.35	6.5			
			32	10.5	12			
			HSI clock source (16 MHz)	Range2, V <sub>CORE</sub> =1.5 V VOS[1:0]=10	16	4.35	5.2	mA
				Range1, V <sub>CORE</sub> =1.8 V VOS[1:0]=01	32	10.5	12.3	
			MSI clock, 65 kHz	Range3, V <sub>CORE</sub> =1.2 V VOS[1:0]=11	0.065	46	130	μA
			MSI clock, 524 kHz		0.524	160	250	
			MSI clock, 4.2 MHz		4.2	965	1200	

1. Guaranteed by characterization results, not tested in production, unless otherwise specified.
2. Oscillator bypassed (HSEBYP = 1 in RCC\_CR register).

**Table 17. Current consumption in Run mode, code with data processing running from RAM**

Symbol	Parameter	Conditions	f <sub>HCLK</sub>	Typ	Max	Unit		
I <sub>DD</sub> (Run from RAM)	Supply current in Run mode code executed from RAM	f <sub>HSE</sub> = f <sub>HCLK</sub> up to 16 MHz, included f <sub>HSE</sub> = f <sub>HCLK</sub> /2 above 16MHz (PLL ON) <sup>(1)</sup>	Range3, V <sub>CORE</sub> =1.2 V VOS[1:0]=11	1	230	470	μA	
				2	415	780		
				4	800	1200		
				Range2, V <sub>CORE</sub> =1.5 V VOS[1:0]=10	4	0.935	1.5	mA
				8	1.9	3		
				16	3.75	5		
			Range1, V <sub>CORE</sub> =1.8 V VOS[1:0]=01	8	2.25	3.5		
			16	4.45	5.55			
			32	9.05	10.9			
			HSI clock source (16 MHz)	Range2, V <sub>CORE</sub> =1.5 V VOS[1:0]=10	16	3.75	4.8	
				Range1, V <sub>CORE</sub> =1.8 V VOS[1:0]=01	32	8.95	11.7	
			MSI clock, 65 kHz	Range3, V <sub>CORE</sub> =1.2 V VOS[1:0]=11	0.065	43.5	100	μA
			MSI clock, 524 kHz		0.524	135	215	
			MSI clock, 4.2 MHz		4.2	835	1100	

1. Oscillator bypassed (HSEBYP = 1 in RCC\_CR register).

Table 18. Current consumption in Sleep mode

Symbol	Parameter	Conditions	f <sub>HCLK</sub>	Typ	Max (1)	Unit		
I <sub>DD(SLEEP)</sub>	Supply current in Sleep mode, code executed from RAM, Flash switched OFF	f <sub>HSE</sub> = f <sub>HCLK</sub> up to 16 MHz, included f <sub>HSE</sub> = f <sub>HCLK</sub> /2 above 16 MHz (PLL ON) <sup>(2)</sup>	Range3, Vcore=1.2 V VOS[1:0]=11	1	58	220	μA	
				2	96	300		
				4	170	380		
				4	210	500		
				8	400	700		
				16	810	1100		
				8	485	800		
				16	955	1250		
				32	2100	2700		
			HSI clock source (16 MHz)	Range2, Vcore=1.5 V VOS[1:0]=10	16	835		1100
		Range1, Vcore=1.8 V VOS[1:0]=01		32	2100	2700		
			MSI clock, 65 kHz	Range3, Vcore=1.2 V VOS[1:0]=11	0.065	18.5		72
			MSI clock, 524 kHz		0.524	37		92
			MSI clock, 4.2 MHz		4.2	180		273
		Supply current in Sleep mode, Flash switched ON	f <sub>HSE</sub> = f <sub>HCLK</sub> up to 16 MHz, included f <sub>HSE</sub> = f <sub>HCLK</sub> /2 above 16MHz (PLL ON) <sup>(2)</sup>	Range3, Vcore=1.2 V VOS[1:0]=11	1	75		250
					2	115		300
					4	200		380
				Range2, Vcore=1.5 V VOS[1:0]=10	4	230		500
	8				430	700		
	16				840	1120		
	Range1, Vcore=1.8 V VOS[1:0]=01			8	500	800		
				16	980	1300		
				32	2100	2700		
	HSI clock source (16 MHz)		Range2, Vcore=1.5 V VOS[1:0]=10	16	860	1160		
Range1, Vcore=1.8 V VOS[1:0]=01				32	2150	2800		
MSI clock, 65 kHz			Range3, Vcore=1.2 V VOS[1:0]=11	0.065	33,5	90		
MSI clock, 524 kHz	0.524			53	110			
MSI clock, 4.2 MHz	4.2			200	290			

1. Guaranteed by characterization results, not tested in production, unless otherwise specified.

2. Oscillator bypassed (HSEBYP = 1 in RCC\_CR register)

**Table 19. Current consumption in Low-power run mode**

Symbol	Parameter	Conditions			Typ	Max <sup>(1)</sup>	Unit	
I <sub>DD</sub> (LP Run)	Supply current in Low-power run mode	All peripherals OFF, code executed from RAM, Flash switched OFF, V <sub>DD</sub> from 1.65 V to 3.6 V	MSI clock, 65 kHz f <sub>HCLK</sub> = 32 kHz	T <sub>A</sub> = -40 °C to 25 °C	11	14	μA	
				T <sub>A</sub> = 85 °C	26	32		
				T <sub>A</sub> = 105 °C	53	72		
			MSI clock, 65 kHz f <sub>HCLK</sub> = 65 kHz	T <sub>A</sub> = -40 °C to 25 °C	18	21		
				T <sub>A</sub> = 85 °C	33	40		
				T <sub>A</sub> = 105 °C	60	78		
		MSI clock, 131 kHz f <sub>HCLK</sub> = 131 kHz	T <sub>A</sub> = -40 °C to 25 °C	36	41			
			T <sub>A</sub> = 55 °C	39	44			
			T <sub>A</sub> = 85 °C	50	58			
		All peripherals OFF, code executed from Flash, V <sub>DD</sub> from 1.65 V to 3.6 V	MSI clock, 65 kHz f <sub>HCLK</sub> = 32 kHz	T <sub>A</sub> = -40 °C to 25 °C	36	40.5		
				T <sub>A</sub> = 85 °C	53	60		
				T <sub>A</sub> = 105 °C	81	100		
			MSI clock, 65 kHz f <sub>HCLK</sub> = 65 kHz	T <sub>A</sub> = -40 °C to 25 °C	44	49		
				T <sub>A</sub> = 85 °C	61	67		
				T <sub>A</sub> = 105 °C	89	107		
			MSI clock, 131 kHz f <sub>HCLK</sub> = 131 kHz	T <sub>A</sub> = -40 °C to 25 °C	64	71		
				T <sub>A</sub> = 55 °C	68	73		
				T <sub>A</sub> = 85 °C	80	88		
			T <sub>A</sub> = 105 °C	101	110			
I <sub>DD</sub> max (LP Run)	Max allowed current in Low-power run mode		V <sub>DD</sub> from 1.65 V to 3.6 V			-	200	

1. Guaranteed by characterization results, not tested in production, unless otherwise specified.

Table 20. Current consumption in Low-power sleep mode

Symbol	Parameter	Conditions		Typ	Max <sup>(1)</sup>	Unit	
I <sub>DD</sub> (LP Sleep)	Supply current in Low-power sleep mode	All peripherals OFF, V <sub>DD</sub> from 1.65 V to 3.6 V	MSI clock, 65 kHz f <sub>HCLK</sub> = 32 kHz Flash OFF	T <sub>A</sub> = -40 °C to 25 °C	4.4	-	μA
			MSI clock, 65 kHz f <sub>HCLK</sub> = 32 kHz Flash ON	T <sub>A</sub> = -40 °C to 25 °C	18	21	
				T <sub>A</sub> = 85 °C	24	27	
				T <sub>A</sub> = 105 °C	35	43	
			MSI clock, 65 kHz f <sub>HCLK</sub> = 65 kHz, Flash ON	T <sub>A</sub> = -40 °C to 25 °C	18.6	21	
				T <sub>A</sub> = 85 °C	24.5	28	
				T <sub>A</sub> = 105 °C	35	42	
			MSI clock, 131 kHz f <sub>HCLK</sub> = 131 kHz, Flash ON	T <sub>A</sub> = -40 °C to 25 °C	22	25	
		T <sub>A</sub> = 55 °C		23.5	26		
		T <sub>A</sub> = 85 °C		28.5	31		
		TIM9 and USART1 enabled, Flash ON, V <sub>DD</sub> from 1.65 V to 3.6 V	MSI clock, 65 kHz f <sub>HCLK</sub> = 32 kHz	T <sub>A</sub> = -40 °C to 25 °C	18	20.5	
				T <sub>A</sub> = 85 °C	24	27	
				T <sub>A</sub> = 105 °C	35	43	
			MSI clock, 65 kHz f <sub>HCLK</sub> = 65 kHz	T <sub>A</sub> = -40 °C to 25 °C	18.6	21	
				T <sub>A</sub> = 85 °C	24.5	28	
				T <sub>A</sub> = 105 °C	35	42	
MSI clock, 131 kHz f <sub>HCLK</sub> = 131 kHz	T <sub>A</sub> = -40 °C to 25 °C		22	25			
	T <sub>A</sub> = 55 °C		23.5	26			
	T <sub>A</sub> = 85 °C	28.5	31				
	T <sub>A</sub> = 105 °C	39	45				
	I <sub>DD</sub> max (LP Sleep)	Max allowed current in Low-power sleep mode	V <sub>DD</sub> from 1.65 V to 3.6 V	-	200		

1. Guaranteed by characterization results, not tested in production, unless otherwise specified.

Table 21. Typical and maximum current consumptions in Stop mode

Symbol	Parameter	Conditions		Typ	Max <sup>(1)</sup>	Unit	
I <sub>DD</sub> (Stop with RTC)	Supply current in Stop mode with RTC enabled	RTC clocked by LSI or LSE external clock (32.768kHz), regulator in LP mode, HSI and HSE OFF (no independent watchdog)	LCD OFF	T <sub>A</sub> = -40°C to 25°C V <sub>DD</sub> = 1.8 V	1.1	-	μA
				T <sub>A</sub> = -40°C to 25°C	1.35	4	
				T <sub>A</sub> = 55°C	1.95	6	
				T <sub>A</sub> = 85°C	4.35	10	
				T <sub>A</sub> = 105°C	11.0	23	
			LCD ON (static duty) <sup>(2)</sup>	T <sub>A</sub> = -40°C to 25°C	1.65	6	
				T <sub>A</sub> = 55°C	2.1	7	
				T <sub>A</sub> = 85°C	4.7	12	
				T <sub>A</sub> = 105°C	11.0	27	
			LCD ON (1/8 duty) <sup>(3)</sup>	T <sub>A</sub> = -40°C to 25°C	2.5	10	
				T <sub>A</sub> = 55°C	4.65	11	
				T <sub>A</sub> = 85°C	7.25	16	
		T <sub>A</sub> = 105°C		14.0	44		
		RTC clocked by LSE external quartz (32.768kHz), regulator in LP mode, HSI and HSE OFF (no independent watchdog) <sup>(4)</sup>	LCD OFF	T <sub>A</sub> = -40°C to 25°C	1.7	-	
				T <sub>A</sub> = 55°C	2.15	-	
				T <sub>A</sub> = 85°C	4.7	-	
				T <sub>A</sub> = 105°C	11.5	-	
			LCD ON (static duty) <sup>(2)</sup>	T <sub>A</sub> = -40°C to 25°C	1.8	-	
				T <sub>A</sub> = 55°C	2.35	-	
				T <sub>A</sub> = 85°C	4.85	-	
T <sub>A</sub> = 105°C	11.5			-			
LCD ON (1/8 duty) <sup>(3)</sup>	T <sub>A</sub> = -40°C to 25°C		2.45	-			
	T <sub>A</sub> = 55°C		4.9	-			
	T <sub>A</sub> = 85°C		7.7	-			
	T <sub>A</sub> = 105°C		14.5	-			
LCD OFF	T <sub>A</sub> = -40°C to 25°C V <sub>DD</sub> = 1.8V	1.35	-				
	T <sub>A</sub> = -40°C to 25°C V <sub>DD</sub> = 3.0V	1.7	-				
	T <sub>A</sub> = -40°C to 25°C V <sub>DD</sub> = 3.6V	2.0	-				

Table 21. Typical and maximum current consumptions in Stop mode (continued)

Symbol	Parameter	Conditions		Typ	Max <sup>(1)</sup>	Unit
I <sub>DD</sub> (Stop)	Supply current in Stop mode (RTC disabled)	Regulator in LP mode, HSI and HSE OFF, independent watchdog and LSI enabled	T <sub>A</sub> = -40°C to 25°C	1.6	2.2	μA
			T <sub>A</sub> = -40°C to 25°C	0.475	1	
		Regulator in LP mode, LSI, HSI and HSE OFF (no independent watchdog)	T <sub>A</sub> = 55°C	0.915	3	
			T <sub>A</sub> = 85°C	3.35	9	
		T <sub>A</sub> = 105°C	10.0	22 <sup>(5)</sup>		
I <sub>DD</sub> (WU from Stop)	Supply current during wakeup from Stop mode	MSI = 4.2 MHz	T <sub>A</sub> = -40°C to 25°C	2	-	mA
		MSI = 1.05 MHz		1.45	-	
		MSI = 65 kHz <sup>(6)</sup>		1.45	-	

1. Guaranteed by characterization results, not tested in production, unless otherwise specified.
2. LCD enabled with external VLCD, static duty, division ratio = 256, all pixels active, no LCD connected.
3. LCD enabled with external VLCD, 1/8 duty, 1/3 bias, division ratio = 64, all pixels active, no LCD connected.
4. Based on characterization done with a 32.768 kHz crystal (MC306-G-06Q-32.768, manufacturer JFVNY) with two 6.8 pF loading capacitors.
5. Guaranteed by test in production.
6. When MSI = 64 kHz, the RMS current is measured over the first 15 μs following the wakeup event. For the remaining part of the wakeup period, the current corresponds the Run mode current.

**Table 22. Typical and maximum current consumptions in Standby mode**

Symbol	Parameter	Conditions	Typ	Max <sup>(1)</sup>	Unit	
I <sub>DD</sub> (Standby with RTC)	Supply current in Standby mode with RTC enabled	RTC clocked by LSI (no independent watchdog)	T <sub>A</sub> = -40 °C to 25 °C V <sub>DD</sub> = 1.8 V	0.82	-	μA
			T <sub>A</sub> = -40 °C to 25 °C	1.15	1.9	
			T <sub>A</sub> = 55 °C	1.15	2.2	
			T <sub>A</sub> = 85 °C	1.65	4	
			T <sub>A</sub> = 105 °C	2.75	8.3 <sup>(2)</sup>	
		RTC clocked by LSE external quartz (no independent watchdog) <sup>(3)</sup>	T <sub>A</sub> = -40 °C to 25 °C V <sub>DD</sub> = 1.8 V	1.05	-	
			T <sub>A</sub> = -40 °C to 25 °C	1.35	-	
			T <sub>A</sub> = 55 °C	1.55	-	
			T <sub>A</sub> = 85 °C	2.1	-	
			T <sub>A</sub> = 105 °C	3.3	-	
I <sub>DD</sub> (Standby)	Supply current in Standby mode (RTC disabled)	Independent watchdog and LSI enabled	T <sub>A</sub> = -40 °C to 25 °C	1	1.7	
			Independent watchdog and LSI OFF	T <sub>A</sub> = -40 °C to 25 °C	0.305	0.6
		T <sub>A</sub> = 55 °C		0.365	0.9	
		T <sub>A</sub> = 85 °C		0.66	2.75	
		T <sub>A</sub> = 105 °C		2	7 <sup>(2)</sup>	
I <sub>DD</sub> (WU from Standby)	Supply current during wakeup time from Standby mode	T <sub>A</sub> = -40 °C to 25 °C	1	-	mA	

1. Guaranteed by characterization results, not tested in production, unless otherwise specified.
2. Guaranteed by test in production.
3. Based on characterization done with a 32.768 kHz crystal (MC306-G-06Q-32.768, manufacturer JFVNY) with two 6.8pF loading capacitors.

### On-chip peripheral current consumption

The current consumption of the on-chip peripherals is given in the following table. The MCU is placed under the following conditions:

- all I/O pins are in input mode with a static value at V<sub>DD</sub> or V<sub>SS</sub> (no load)
- all peripherals are disabled unless otherwise mentioned
- the given value is calculated by measuring the current consumption
  - with all peripherals clocked off
  - with only one peripheral clocked on

Table 23. Peripheral current consumption<sup>(1)</sup>

Peripheral		Typical consumption, V <sub>DD</sub> = 3.0 V, T <sub>A</sub> = 25 °C				Unit
		Range 1, V <sub>CORE</sub> = 1.8 V VOS[1:0] = 01	Range 2, V <sub>CORE</sub> = 1.5 V VOS[1:0] = 10	Range 3, V <sub>CORE</sub> = 1.2 V VOS[1:0] = 11	Low-power sleep and run	
APB1	TIM2	14.3	12.1	9.5	12.1	μA/MHz (f <sub>HCLK</sub> )
	TIM3	13.8	11.7	9.2	11.7	
	TIM4	13.2	11.1	8.7	11.1	
	TIM5	17.7	14.9	11.8	14.9	
	TIM6	4.8	4.0	3.0	4.0	
	TIM7	4.7	3.9	3.0	3.9	
	LCD	5.0	4.1	3.3	4.1	
	WWDG	3.5	2.9	2.3	2.9	
	SPI2	8.9	7.4	5.8	7.4	
	SPI3	7.3	6.0	4.8	6.0	
	USART2	9.4	7.7	6.1	7.7	
	USART3	9.4	7.6	6.0	7.6	
	USART4	10.1	8.4	6.7	8.4	
	USART5	9.5	7.9	6.3	7.9	
	I2C1	8.9	7.4	5.8	7.4	
	I2C2	7.9	6.4	5.1	6.4	
	USB	21.2	18.0	14.3	18.0	
	PWR	4.0	3.2	2.5	3.2	
	DAC	6.3	5.5	4.4	5.5	
COMP	4.9	3.9	3.2	3.9		

Table 23. Peripheral current consumption<sup>(1)</sup> (continued)

Peripheral		Typical consumption, V <sub>DD</sub> = 3.0 V, T <sub>A</sub> = 25 °C				Unit
		Range 1, V <sub>CORE</sub> = 1.8 V VOS[1:0] = 01	Range 2, V <sub>CORE</sub> = 1.5 V VOS[1:0] = 10	Range 3, V <sub>CORE</sub> = 1.2 V VOS[1:0] = 11	Low-power sleep and run	
APB2	SYSCFG & RI	3.5	2.9	2.4	2.9	μA/MHz (f <sub>HCLK</sub> )
	TIM9	9.0	7.4	5.8	7.4	
	TIM10	7.1	5.8	4.6	5.8	
	TIM11	6.5	5.3	4.3	5.3	
	ADC <sup>(2)</sup>	11.0	9.1	7.2	9.1	
	SDIO	28.4	24.2	19.1	24.2	
	SPI1	5.1	4.2	3.3	4.2	
	USART1	9.4	7.8	6.1	7.8	
AHB	GPIOA	7.3	6.1	4.8	6.1	
	GPIOB	7.5	6.1	4.8	6.1	
	GPIOC	8.2	6.8	5.3	6.8	
	GIOD	8.7	7.1	5.7	7.1	
	GPIOE	7.6	6.2	4.9	6.2	
	GPIOF	7.7	6.3	5.0	6.3	
	GPIOG	8.4	7.0	5.4	7.0	
	GPIOH	1.8	1.3	1.1	1.3	
	CRC	0.8	0.6	0.4	0.6	
	AES	5	4	3	4	
	FLASH	26.3	19.3	18.3	_(3)	
	DMA1	19.0	16.0	12.8	16.0	
	DMA2	17.0	14.5	11.5	14.5	
All enabled		315	250	220	230.7	

Table 23. Peripheral current consumption<sup>(1)</sup> (continued)

Peripheral	Typical consumption, V <sub>DD</sub> = 3.0 V, T <sub>A</sub> = 25 °C				Unit
	Range 1, V <sub>CORE</sub> = 1.8 V VOS[1:0] = 01	Range 2, V <sub>CORE</sub> = 1.5 V VOS[1:0] = 10	Range 3, V <sub>CORE</sub> = 1.2 V VOS[1:0] = 11	Low-power sleep and run	
I <sub>DD</sub> (RTC)	0.4				μA
I <sub>DD</sub> (LCD)	3.1				
I <sub>DD</sub> (ADC) <sup>(4)</sup>	1450				
I <sub>DD</sub> (DAC) <sup>(5)</sup>	340				
I <sub>DD</sub> (COMP1)	0.16				
I <sub>DD</sub> (COMP2)	Slow mode	2			
	Fast mode	5			
I <sub>DD</sub> (PVD / BOR) <sup>(6)</sup>	2.6				
I <sub>DD</sub> (IWDG)	0.25				

1. Data based on differential I<sub>DD</sub> measurement between all peripherals OFF and one peripheral with clock enabled, in the following conditions: f<sub>HCLK</sub> = 32 MHz (range 1), f<sub>HCLK</sub> = 16 MHz (range 2), f<sub>HCLK</sub> = 4 MHz (range 3), f<sub>HCLK</sub> = 64kHz (Low-power run/sleep), f<sub>APB1</sub> = f<sub>HCLK</sub>, f<sub>APB2</sub> = f<sub>HCLK</sub>, default prescaler value for each peripheral. The CPU is in Sleep mode in both cases. No I/O pins toggling. Not tested in production.
2. HSI oscillator is OFF for this measure.
3. In Low-power sleep and run mode, the Flash memory must always be in power-down mode.
4. Data based on a differential I<sub>DD</sub> measurement between ADC in reset configuration and continuous ADC conversion (HSI consumption not included).
5. Data based on a differential I<sub>DD</sub> measurement between DAC in reset configuration and continuous DAC conversion of V<sub>DD</sub>/2. DAC is in buffered mode, output is left floating.
6. Including supply current of internal reference voltage.

### 6.3.5 Wakeup time from low-power mode

The wakeup times given in the following table are measured with the MSI RC oscillator. The clock source used to wake up the device depends on the current operating mode:

- Sleep mode: the clock source is the clock that was set before entering Sleep mode
- Stop mode: the clock source is the MSI oscillator in the range configured before entering Stop mode
- Standby mode: the clock source is the MSI oscillator running at 2.1 MHz

All timings are derived from tests performed under the conditions summarized in [Table 12](#).

Table 24. Low-power mode wakeup timings

Symbol	Parameter	Conditions	Typ	Max <sup>(1)</sup>	Unit
$t_{WUSLEEP}$	Wakeup from Sleep mode	$f_{HCLK} = 32 \text{ MHz}$	0.4	-	$\mu\text{s}$
$t_{WUSLEEP\_LP}$	Wakeup from Low-power sleep mode, $f_{HCLK} = 262 \text{ kHz}$	$f_{HCLK} = 262 \text{ kHz}$ Flash enabled	46	-	
		$f_{HCLK} = 262 \text{ kHz}$ Flash switched OFF	46	-	
$t_{WUSTOP}$	Wakeup from Stop mode, regulator in Run mode ULP bit = 1 and FWU bit = 1	$f_{HCLK} = f_{MSI} = 4.2 \text{ MHz}$	8.2	-	
	Wakeup from Stop mode, regulator in low-power mode ULP bit = 1 and FWU bit = 1	$f_{HCLK} = f_{MSI} = 4.2 \text{ MHz}$ Voltage range 1 and 2	7.7	8.9	
		$f_{HCLK} = f_{MSI} = 4.2 \text{ MHz}$ Voltage range 3	8.2	13.1	
		$f_{HCLK} = f_{MSI} = 2.1 \text{ MHz}$	10.2	13.4	
		$f_{HCLK} = f_{MSI} = 1.05 \text{ MHz}$	16	20	
		$f_{HCLK} = f_{MSI} = 524 \text{ kHz}$	31	37	
		$f_{HCLK} = f_{MSI} = 262 \text{ kHz}$	57	66	
		$f_{HCLK} = f_{MSI} = 131 \text{ kHz}$	112	123	
$f_{HCLK} = \text{MSI} = 65 \text{ kHz}$	221	236			
$t_{WUSTDBY}$	Wakeup from Standby mode ULP bit = 1 and FWU bit = 1	$f_{HCLK} = \text{MSI} = 2.1 \text{ MHz}$	58	104	ms
	Wakeup from Standby mode FWU bit = 0	$f_{HCLK} = \text{MSI} = 2.1 \text{ MHz}$	2.6	3.25	

1. Guaranteed by characterization, not tested in production, unless otherwise specified

### 6.3.6 External clock source characteristics

#### High-speed external user clock generated from an external source

In bypass mode the HSE oscillator is switched off and the input pin is a standard GPIO. The external clock signal has to respect the I/O characteristics in [Section 6.3.13](#). However, the recommended clock input waveform is shown in [Figure 14](#).

Table 25. High-speed external user clock characteristics<sup>(1)</sup>

Symbol	Parameter	Conditions	Min	Typ	Max	Unit
$f_{HSE\_ext}$	User external clock source frequency	CSS is on or PLL is used	1	8	32	MHz
		CSS is off, PLL not used	0	8	32	MHz

Table 25. High-speed external user clock characteristics<sup>(1)</sup> (continued)

Symbol	Parameter	Conditions	Min	Typ	Max	Unit
$V_{HSEH}$	OSC_IN input pin high level voltage	-	$0.7V_{DD}$	-	$V_{DD}$	V
$V_{HSEL}$	OSC_IN input pin low level voltage		$V_{SS}$	-	$0.3V_{DD}$	
$t_{w(HSEH)}$ $t_{w(HSEL)}$	OSC_IN high or low time		12	-	-	ns
$t_r(HSE)$ $t_f(HSE)$	OSC_IN rise or fall time		-	-	20	
$C_{in(HSE)}$	OSC_IN input capacitance		-	2.6	-	pF

1. Guaranteed by design, not tested in production.

Figure 14. High-speed external clock source AC timing diagram

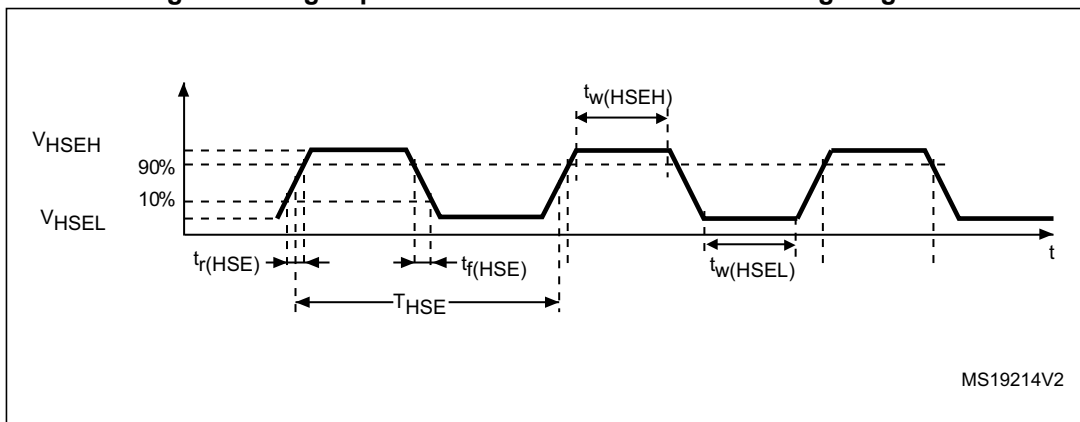

**Low-speed external user clock generated from an external source**

The characteristics given in the following table result from tests performed using a low-speed external clock source, and under the conditions summarized in [Table 12](#).

**Table 26. Low-speed external user clock characteristics<sup>(1)</sup>**

Symbol	Parameter	Conditions	Min	Typ	Max	Unit
$f_{LSE\_ext}$	User external clock source frequency	-	1	32.768	1000	kHz
$V_{LSEH}$	OSC32_IN input pin high level voltage	-	$0.7V_{DD}$	-	$V_{DD}$	V
$V_{LSEL}$	OSC32_IN input pin low level voltage	-	$V_{SS}$	-	$0.3V_{DD}$	
$t_{w(LSEH)}$ $t_{w(LSEL)}$	OSC32_IN high or low time	-	465	-	-	ns
$t_{r(LSE)}$ $t_{f(LSE)}$	OSC32_IN rise or fall time	-	-	-	10	
$C_{IN(LSE)}$	OSC32_IN input capacitance	-	-	0.6	-	pF

1. Guaranteed by design, not tested in production

**Figure 15. Low-speed external clock source AC timing diagram**

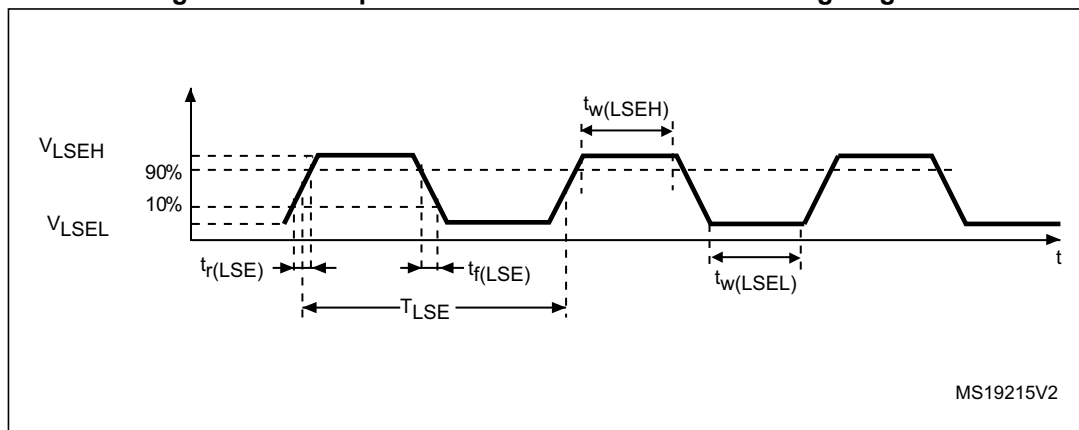

**High-speed external clock generated from a crystal/ceramic resonator**

The high-speed external (HSE) clock can be supplied with a 1 to 24 MHz crystal/ceramic resonator oscillator. All the information given in this paragraph are based on characterization results obtained with typical external components specified in [Table 27](#). In the application, the resonator and the load capacitors have to be placed as close as possible to the oscillator pins in order to minimize output distortion and startup stabilization time. Refer to the crystal resonator manufacturer for more details on the resonator characteristics (frequency, package, accuracy).

Table 27. HSE oscillator characteristics<sup>(1)(2)</sup>

Symbol	Parameter	Conditions	Min	Typ	Max	Unit
$f_{OSC\_IN}$	Oscillator frequency	-	1		24	MHz
$R_F$	Feedback resistor	-	-	200	-	k $\Omega$
C	Recommended load capacitance versus equivalent serial resistance of the crystal ( $R_S$ ) <sup>(3)</sup>	$R_S = 30 \Omega$	-	20	-	pF
$I_{HSE}$	HSE driving current	$V_{DD} = 3.3 V$ , $V_{IN} = V_{SS}$ with 30 pF load	-	-	3	mA
$I_{DD(HSE)}$	HSE oscillator power consumption	C = 20 pF $f_{OSC} = 16 MHz$	-	-	2.5 (startup) 0.7 (stabilized)	mA
		C = 10 pF $f_{OSC} = 16 MHz$	-	-	2.5 (startup) 0.46 (stabilized)	
$g_m$	Oscillator transconductance	Startup	3.5	-	-	mA / V
$t_{SU(HSE)}$ <sup>(4)</sup>	Startup time	$V_{DD}$ is stabilized	-	1	-	ms

1. Resonator characteristics given by the crystal/ceramic resonator manufacturer.
2. Guaranteed by characterization results, not tested in production.
3. The relatively low value of the RF resistor offers a good protection against issues resulting from use in a humid environment, due to the induced leakage and the bias condition change. However, it is recommended to take this point into account if the MCU is used in tough humidity conditions.
4.  $t_{SU(HSE)}$  is the startup time measured from the moment it is enabled (by software) to a stabilized 8 MHz oscillation is reached. This value is measured for a standard crystal resonator and it can vary significantly with the crystal manufacturer.

For  $C_{L1}$  and  $C_{L2}$ , it is recommended to use high-quality external ceramic capacitors in the 5 pF to 25 pF range (typ.), designed for high-frequency applications, and selected to match the requirements of the crystal or resonator (see [Figure 16](#)).  $C_{L1}$  and  $C_{L2}$  are usually the same size. The crystal manufacturer typically specifies a load capacitance which is the series combination of  $C_{L1}$  and  $C_{L2}$ . PCB and MCU pin capacitance must be included (10 pF can be used as a rough estimate of the combined pin and board capacitance) when sizing  $C_{L1}$  and  $C_{L2}$ . Refer to the application note AN2867 "Oscillator design guide for ST microcontrollers" available from the ST website [www.st.com](http://www.st.com).

Figure 16. HSE oscillator circuit diagram

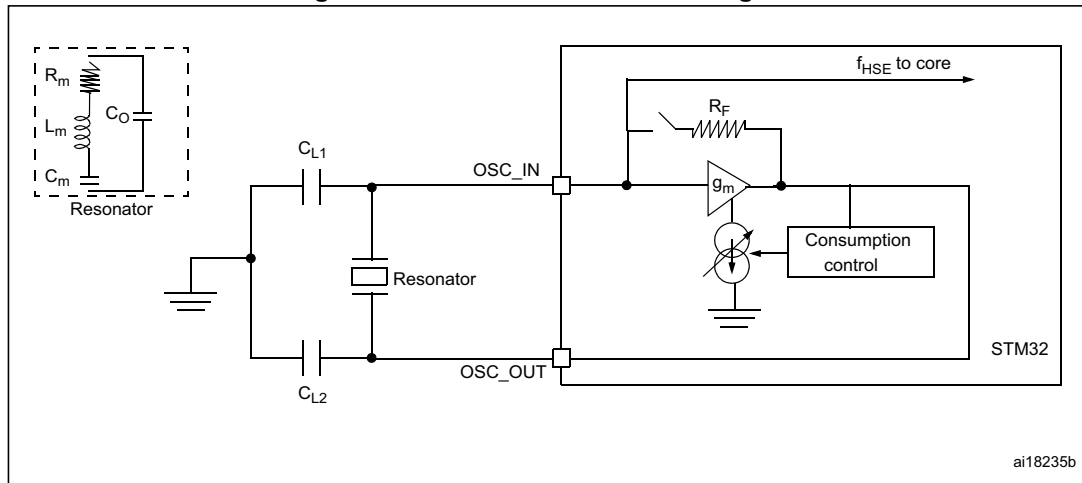

1.  $R_{EXT}$  value depends on the crystal characteristics.

**Low-speed external clock generated from a crystal/ceramic resonator**

The low-speed external (LSE) clock can be supplied with a 32.768 kHz crystal/ceramic resonator oscillator. All the information given in this paragraph are based on characterization results obtained with typical external components specified in [Table 28](#). In the application, the resonator and the load capacitors have to be placed as close as possible to the oscillator pins in order to minimize output distortion and startup stabilization time. Refer to the crystal resonator manufacturer for more details on the resonator characteristics (frequency, package, accuracy).

Table 28. LSE oscillator characteristics ( $f_{LSE} = 32.768 \text{ kHz}$ )<sup>(1)</sup>

Symbol	Parameter	Conditions	Min	Typ	Max	Unit
$f_{LSE}$	Low speed external oscillator frequency	-	-	32.768	-	kHz
$R_F$	Feedback resistor	-	-	1.2	-	MΩ
$C^{(2)}$	Recommended load capacitance versus equivalent serial resistance of the crystal ( $R_S$ ) <sup>(3)</sup>	$R_S = 30 \text{ k}\Omega$	-	8	-	pF
$I_{LSE}$	LSE driving current	$V_{DD} = 3.3 \text{ V}, V_{IN} = V_{SS}$	-	-	1.1	μA
$I_{DD (LSE)}$	LSE oscillator current consumption	$V_{DD} = 1.8 \text{ V}$	-	450	-	nA
		$V_{DD} = 3.0 \text{ V}$	-	600	-	
		$V_{DD} = 3.6 \text{ V}$	-	750	-	
$g_m$	Oscillator transconductance	-	3	-	-	μA/V
$t_{SU(LSE)}^{(4)}$	Startup time	$V_{DD}$ is stabilized	-	1	-	s

1. Guaranteed by characterization results, not tested in production.
2. Refer to the note and caution paragraphs below the table, and to the application note AN2867 "Oscillator design guide for ST microcontrollers".
3. The oscillator selection can be optimized in terms of supply current using an high quality resonator with small  $R_S$  value for example MSIV-TIN32.768kHz. Refer to crystal manufacturer for more details.

4.  $t_{SU(LSE)}$  is the startup time measured from the moment it is enabled (by software) to a stabilized 32.768 kHz oscillation is reached. This value is measured for a standard crystal resonator and it can vary significantly with the crystal manufacturer.

**Note:** For  $C_{L1}$  and  $C_{L2}$ , it is recommended to use high-quality ceramic capacitors in the 5 pF to 15 pF range selected to match the requirements of the crystal or resonator (see Figure 17).  $C_{L1}$  and  $C_{L2}$  are usually the same size. The crystal manufacturer typically specifies a load capacitance which is the series combination of  $C_{L1}$  and  $C_{L2}$ . Load capacitance  $C_L$  has the following formula:  $C_L = C_{L1} \times C_{L2} / (C_{L1} + C_{L2}) + C_{stray}$  where  $C_{stray}$  is the pin capacitance and board or trace PCB-related capacitance. Typically, it is between 2 pF and 7 pF.

**Caution:** To avoid exceeding the maximum value of  $C_{L1}$  and  $C_{L2}$  (15 pF) it is strongly recommended to use a resonator with a load capacitance  $C_L \leq 7$  pF. Never use a resonator with a load capacitance of 12.5 pF.

**Example:** if you choose a resonator with a load capacitance of  $C_L = 6$  pF and  $C_{stray} = 2$  pF, then  $C_{L1} = C_{L2} = 8$  pF.

Figure 17. Typical application with a 32.768 kHz crystal

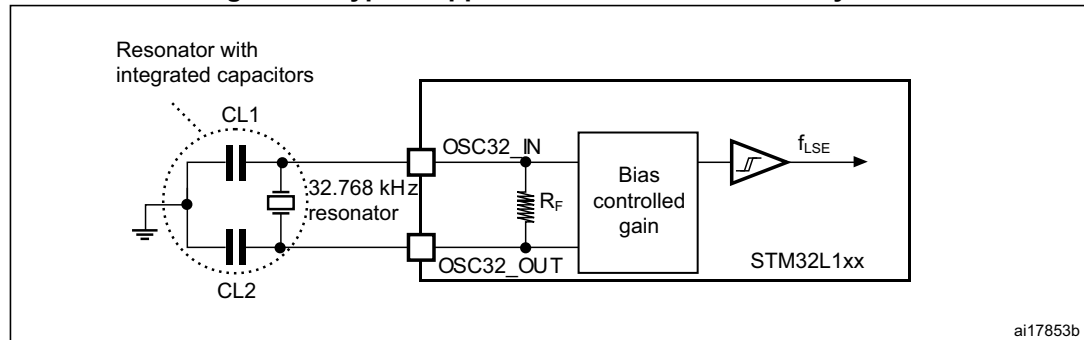

### 6.3.7 Internal clock source characteristics

The parameters given in [Table 29](#) are derived from tests performed under the conditions summarized in [Table 12](#).

#### High-speed internal (HSI) RC oscillator

**Table 29. HSI oscillator characteristics**

Symbol	Parameter	Conditions	Min	Typ	Max	Unit
$f_{\text{HSI}}$	Frequency	$V_{\text{DD}} = 3.0 \text{ V}$	-	16	-	MHz
$\text{TRIM}^{(1)(2)}$	HSI user-trimmed resolution	Trimming code is not a multiple of 16	-	$\pm 0.4$	0.7	%
		Trimming code is a multiple of 16	-	-	$\pm 1.5$	%
$\text{ACC}_{\text{HSI}}^{(2)}$	Accuracy of the factory-calibrated HSI oscillator	$V_{\text{DDA}} = 3.0 \text{ V}, T_{\text{A}} = 25 \text{ }^\circ\text{C}$	-1 <sup>(3)</sup>	-	1 <sup>(3)</sup>	%
		$V_{\text{DDA}} = 3.0 \text{ V}, T_{\text{A}} = 0 \text{ to } 55 \text{ }^\circ\text{C}$	-1.5	-	1.5	%
		$V_{\text{DDA}} = 3.0 \text{ V}, T_{\text{A}} = -10 \text{ to } 70 \text{ }^\circ\text{C}$	-2	-	2	%
		$V_{\text{DDA}} = 3.0 \text{ V}, T_{\text{A}} = -10 \text{ to } 85 \text{ }^\circ\text{C}$	-2.5	-	2	%
		$V_{\text{DDA}} = 3.0 \text{ V}, T_{\text{A}} = -10 \text{ to } 105 \text{ }^\circ\text{C}$	-4	-	2	%
		$V_{\text{DDA}} = 1.65 \text{ V to } 3.6 \text{ V}$ $T_{\text{A}} = -40 \text{ to } 105 \text{ }^\circ\text{C}$	-4	-	3	%
$t_{\text{SU(HSI)}}^{(2)}$	HSI oscillator startup time	-	-	3.7	6	$\mu\text{s}$
$I_{\text{DD(HSI)}}^{(2)}$	HSI oscillator power consumption	-	-	100	140	$\mu\text{A}$

1. The trimming step differs depending on the trimming code. It is usually negative on the codes which are multiples of 16 (0x00, 0x10, 0x20, 0x30...0xE0).
2. Guaranteed by characterization results, not tested in production.
3. Guaranteed by test in production.

#### Low-speed internal (LSI) RC oscillator

**Table 30. LSI oscillator characteristics**

Symbol	Parameter	Min	Typ	Max	Unit
$f_{\text{LSI}}^{(1)}$	LSI frequency	26	38	56	kHz
$D_{\text{LSI}}^{(2)}$	LSI oscillator frequency drift $0^\circ\text{C} \leq T_{\text{A}} \leq 105^\circ\text{C}$	-10	-	4	%
$t_{\text{SU(LSI)}}^{(3)}$	LSI oscillator startup time	-	-	200	$\mu\text{s}$
$I_{\text{DD(LSI)}}^{(3)}$	LSI oscillator power consumption	-	400	510	nA

1. Guaranteed by test in production.
2. This is a deviation for an individual part, once the initial frequency has been measured.
3. Guaranteed by design, not tested in production.

## Multi-speed internal (MSI) RC oscillator

Table 31. MSI oscillator characteristics

Symbol	Parameter	Condition	Typ	Max	Unit	
$f_{\text{MSI}}$	Frequency after factory calibration, done at $V_{\text{DD}} = 3.3 \text{ V}$ and $T_{\text{A}} = 25 \text{ }^{\circ}\text{C}$	MSI range 0	65.5	-	kHz	
		MSI range 1	131	-		
		MSI range 2	262	-		
		MHz	MSI range 3	524	-	MHz
			MSI range 4	1.05	-	
			MSI range 5	2.1	-	
			MSI range 6	4.2	-	
$\text{ACC}_{\text{MSI}}$	Frequency error after factory calibration	-	$\pm 0.5$	-	%	
$D_{\text{TEMP}(\text{MSI})}^{(1)}$	MSI oscillator frequency drift $0 \text{ }^{\circ}\text{C} \leq T_{\text{A}} \leq 105 \text{ }^{\circ}\text{C}$	-	$\pm 3$	-	%	
$D_{\text{VOLT}(\text{MSI})}^{(1)}$	MSI oscillator frequency drift $1.65 \text{ V} \leq V_{\text{DD}} \leq 3.6 \text{ V}$ , $T_{\text{A}} = 25 \text{ }^{\circ}\text{C}$	-	-	2.5	%/V	
$I_{\text{DD}(\text{MSI})}^{(2)}$	MSI oscillator power consumption	MSI range 0	0.75	-	$\mu\text{A}$	
		MSI range 1	1	-		
		MSI range 2	1.5	-		
		MSI range 3	2.5	-		
		MSI range 4	4.5	-		
		MSI range 5	8	-		
		MSI range 6	15	-		
$t_{\text{SU}(\text{MSI})}$	MSI oscillator startup time	MSI range 0	30	-	$\mu\text{s}$	
		MSI range 1	20	-		
		MSI range 2	15	-		
		MSI range 3	10	-		
		MSI range 4	6	-		
		MSI range 5	5	-		
		MSI range 6, Voltage range 1 and 2	3.5	-		
		MSI range 6, Voltage range 3	5	-		

Table 31. MSI oscillator characteristics (continued)

Symbol	Parameter	Condition	Typ	Max	Unit
$t_{\text{STAB(MSI)}}^{(2)}$	MSI oscillator stabilization time	MSI range 0	-	40	$\mu\text{s}$
		MSI range 1	-	20	
		MSI range 2	-	10	
		MSI range 3	-	4	
		MSI range 4	-	2.5	
		MSI range 5	-	2	
		MSI range 6, Voltage range 1 and 2	-	2	
$f_{\text{OVER(MSI)}}$	MSI oscillator frequency overshoot	Any range to range 5	-	4	MHz
		Any range to range 6	-	6	

1. This is a deviation for an individual part, once the initial frequency has been measured.
2. Guaranteed by characterization results, not tested in production.

### 6.3.8 PLL characteristics

The parameters given in [Table 32](#) are derived from tests performed under the conditions summarized in [Table 12](#).

**Table 32. PLL characteristics**

Symbol	Parameter	Value			Unit
		Min	Typ	Max <sup>(1)</sup>	
f <sub>PLL_IN</sub>	PLL input clock <sup>(2)</sup>	2	-	24	MHz
	PLL input clock duty cycle	45	-	55	%
f <sub>PLL_OUT</sub>	PLL output clock	2	-	32	MHz
t <sub>LOCK</sub>	PLL lock time PLL input = 16 MHz PLL VCO = 96 MHz	-	115	160	μs
Jitter	Cycle-to-cycle jitter	-	-	± 600	ps
I <sub>DDA</sub> (PLL)	Current consumption on V <sub>DDA</sub>	-	220	450	μA
I <sub>DD</sub> (PLL)	Current consumption on V <sub>DD</sub>	-	120	150	

1. Guaranteed by characterization results, not tested in production.
2. Take care of using the appropriate multiplier factors so as to have PLL input clock values compatible with the range defined by f<sub>PLL\_OUT</sub>.

### 6.3.9 Memory characteristics

The characteristics are given at T<sub>A</sub> = -40 to 105 °C unless otherwise specified.

#### RAM memory

**Table 33. RAM and hardware registers**

Symbol	Parameter	Conditions	Min	Typ	Max	Unit
VRM	Data retention mode <sup>(1)</sup>	STOP mode (or RESET)	1.65	-	-	V

1. Minimum supply voltage without losing data stored in RAM (in Stop mode or under Reset) or in hardware registers (only in Stop mode).

Flash memory and data EEPROM

Table 34. Flash memory and data EEPROM characteristics

Symbol	Parameter	Conditions	Min	Typ	Max <sup>(1)</sup>	Unit
V <sub>DD</sub>	Operating voltage Read / Write / Erase	-	1.65	-	3.6	V
t <sub>prog</sub>	Programming/ erasing time for byte / word / double word / half-page	Erasing	-	3.28	3.94	ms
		Programming	-	3.28	3.94	
I <sub>DD</sub>	Average current during the whole programming / erase operation	T <sub>A</sub> = 25 °C, V <sub>DD</sub> = 3.6 V	-	600	900	µA
	Maximum current (peak) during the whole programming / erase operation		-	1.5	2.5	mA

1. Guaranteed by design, not tested in production.

Table 35. Flash memory and data EEPROM endurance and retention

Symbol	Parameter	Conditions	Value			Unit
			Min <sup>(1)</sup>	Typ	Max	
N <sub>CYC</sub> <sup>(2)</sup>	Cycling (erase / write) Program memory	T <sub>A</sub> = -40°C to 105 °C	10	-	-	kcycles
	Cycling (erase / write) EEPROM data memory		300	-	-	
t <sub>RET</sub> <sup>(2)</sup>	Data retention (program memory) after 10 kcycles at T <sub>A</sub> = 85 °C	T <sub>RET</sub> = +85 °C	30	-	-	years
	Data retention (EEPROM data memory) after 300 kcycles at T <sub>A</sub> = 85 °C		30	-	-	
	Data retention (program memory) after 10 kcycles at T <sub>A</sub> = 105 °C	T <sub>RET</sub> = +105 °C	10	-	-	
	Data retention (EEPROM data memory) after 300 kcycles at T <sub>A</sub> = 105 °C		10	-	-	

1. Guaranteed by characterization results, not tested in production.

2. Characterization is done according to JEDEC JESD22-A117.

### 6.3.10 FSMC characteristics

#### Asynchronous waveforms and timings

Figure 18 through Figure 21 represent asynchronous waveforms and Table 36 through Table 39 provide the corresponding timings. The results shown in these tables are obtained with the following FSMC configuration:

- AddressSetupTime = 0 (AddressSetupTime = 1, for asynchronous multiplexed modes)
- AddressHoldTime = 1
- DataSetupTime = 1

Figure 18. Asynchronous non-multiplexed SRAM/PSRAM/NOR read waveforms

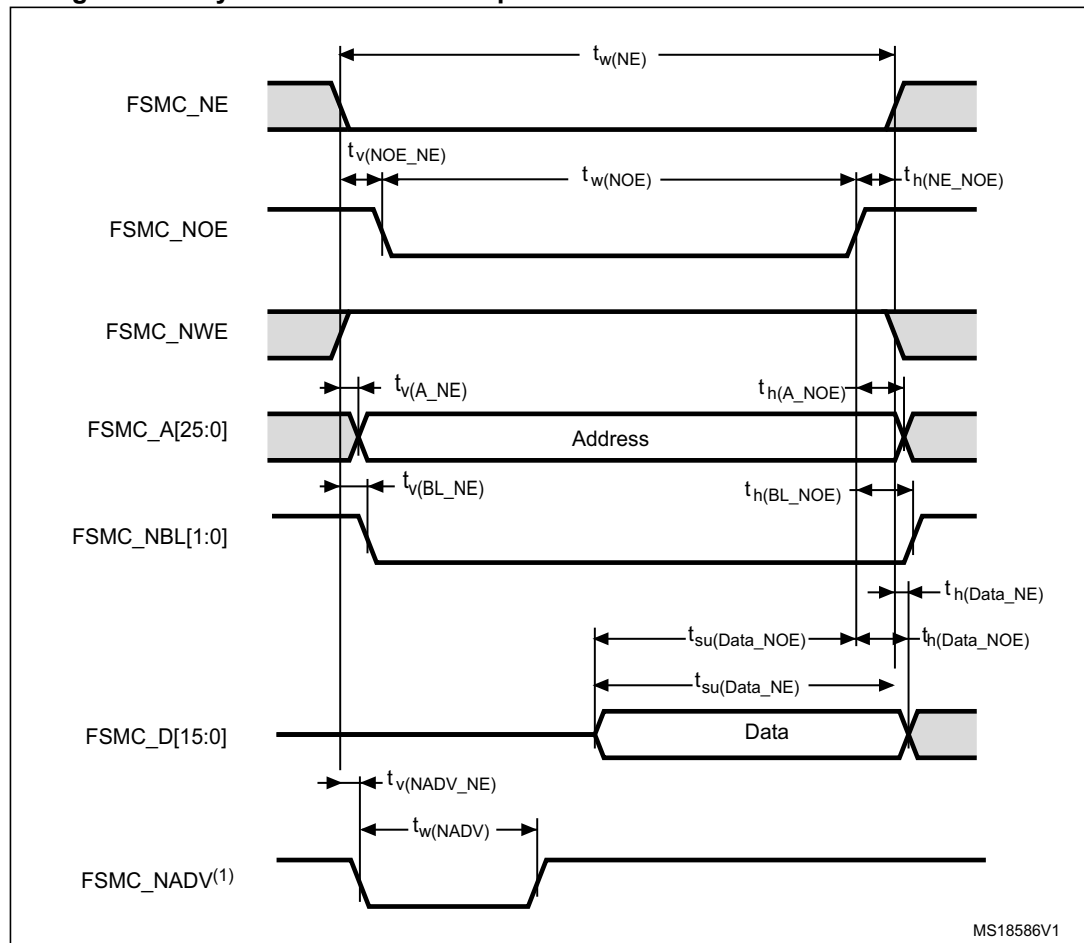

1. Mode 2/B, C and D only. In Mode 1, FSMC\_NADV is not used.

**Table 36. Asynchronous non-multiplexed SRAM/PSRAM/NOR read timings<sup>(1)</sup>**

Symbol	Parameter	Min	Max	Unit
$t_{w(NE)}$	FSMC_NE low time	$T_{HCLK} - 2$	$T_{HCLK}$	ns
$t_{v(NOE\_NE)}$	FSMC_NEx low to FSMC_NOE low	0	2	ns
$t_{w(NOE)}$	FSMC_NOE low time	$T_{HCLK}$	$T_{HCLK} - 1$	ns
$t_{h(NE\_NOE)}$	FSMC_NOE high to FSMC_NE high hold time	0	-	ns
$t_{v(A\_NE)}$	FSMC_NEx low to FSMC_A valid	-	4	ns
$t_{h(A\_NOE)}$	Address hold time after FSMC_NOE high	$T_{HCLK} + 1.5$	-	ns
$t_{v(BL\_NE)}$	FSMC_NEx low to FSMC_BL valid	-	0.5	ns
$t_{h(BL\_NOE)}$	FSMC_BL hold time after FSMC_NOE high	$2 * T_{HCLK} - 0.5$	-	ns
$t_{su(Data\_NE)}$	Data to FSMC_NEx high setup time	$T_{HCLK}$	-	ns
$t_{su(Data\_NOE)}$	Data to FSMC_NOEx high setup time	$T_{HCLK}$	-	ns
$t_{h(Data\_NOE)}$	Data hold time after FSMC_NOE high	0	-	ns
$t_{h(Data\_NE)}$	Data hold time after FSMC_NEx high	0	-	ns
$t_{v(NADV\_NE)}$	FSMC_NEx low to FSMC_NADV low	-	2	ns
$t_{w(NADV)}$	FSMC_NADV low time	-	$T_{HCLK}$	ns

1.  $C_L = 30$  pF.

**Figure 19. Asynchronous non-multiplexed SRAM/PSRAM/NOR write waveforms**

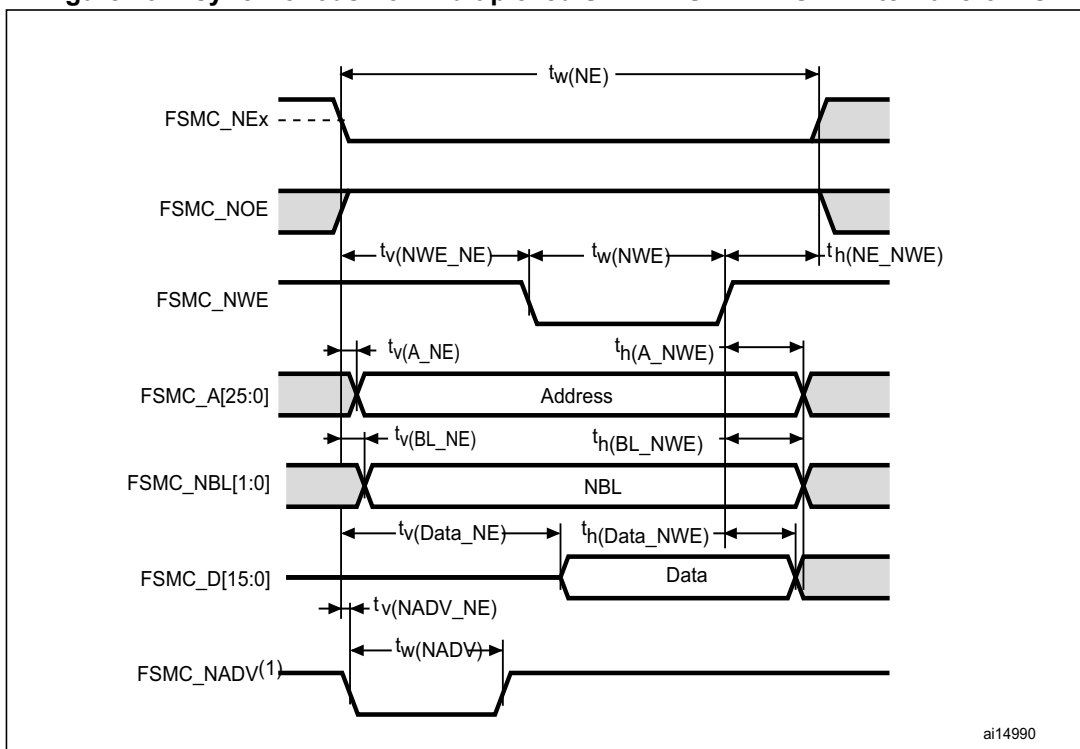

1. Mode 2/B, C and D only. In Mode 1, FSMC\_NADV is not used.

**Table 37. Asynchronous non-multiplexed SRAM/PSRAM/NOR write timings<sup>(1)</sup>**

Symbol	Parameter	Min	Max	Unit
$t_{w(NE)}$	FSMC_NE low time	$2 \cdot T_{HCLK} - 3$	$2 \cdot T_{HCLK} + 2$	ns
$t_{v(NWE\_NE)}$	FSMC_NEx low to FSMC_NWE low	0.5	1	ns
$t_{w(NWE)}$	FSMC_NWE low time	$T_{HCLK} - 2$	$T_{HCLK} + 3$	ns
$t_{h(NE\_NWE)}$	FSMC_NWE high to FSMC_NE high hold time	$T_{HCLK} - 2.5$	-	ns
$t_{v(A\_NE)}$	FSMC_NEx low to FSMC_A valid	-	0	ns
$t_{h(A\_NWE)}$	Address hold time after FSMC_NWE high	$T_{HCLK} - 2.5$	-	ns
$t_{v(BL\_NE)}$	FSMC_NEx low to FSMC_BL valid	-	0	ns
$t_{h(BL\_NWE)}$	FSMC_BL hold time after FSMC_NWE high	$T_{HCLK} - 4$	-	ns
$t_{v(Data\_NE)}$	FSMC_NEx low to Data valid	-	$T_{HCLK}$	ns
$t_{h(Data\_NWE)}$	Data hold time after FSMC_NWE high	$T_{HCLK} - 2.5$	-	ns

1.  $C_L = 30$  pF.

**Figure 20. Asynchronous multiplexed PSRAM/NOR read waveforms**

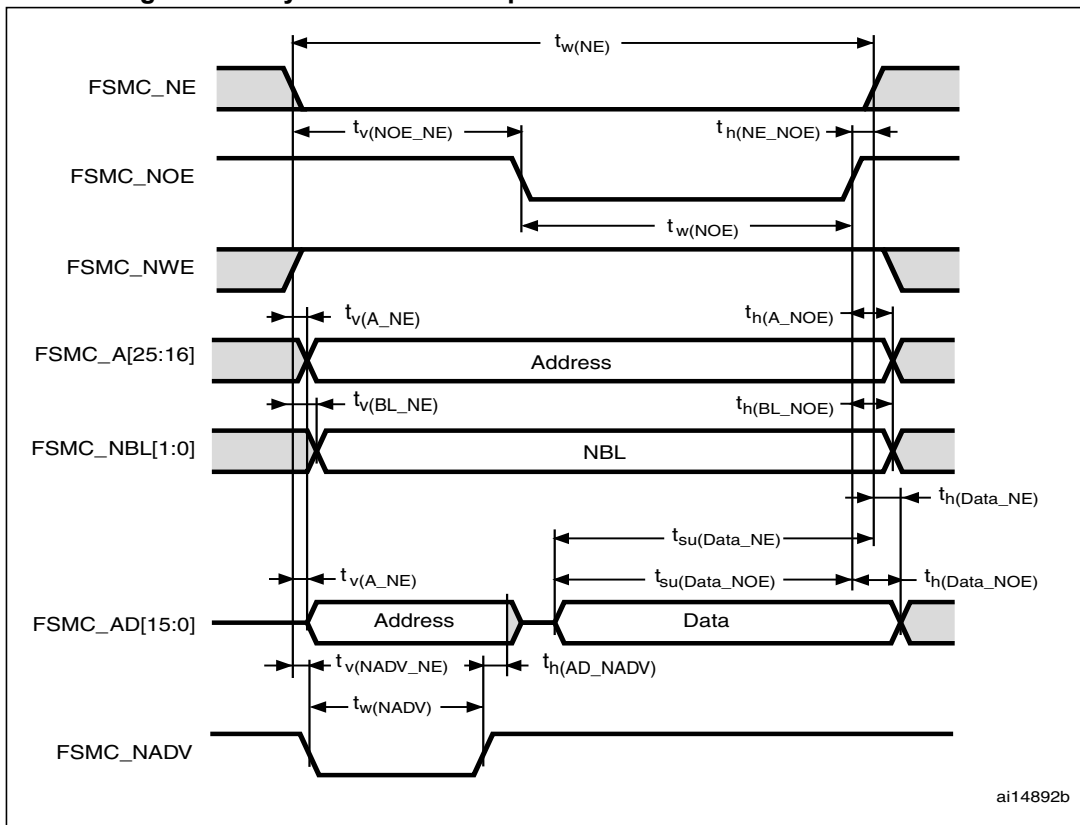
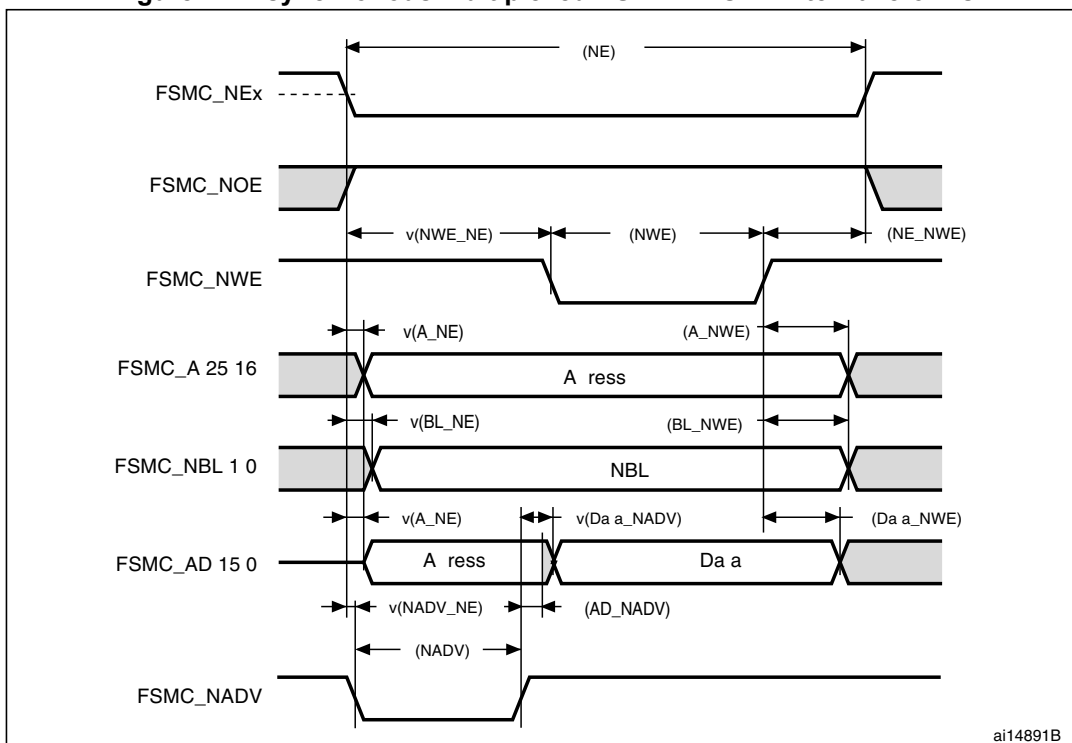

Table 38. Asynchronous multiplexed PSRAM/NOR read timings<sup>(1)</sup>

Symbol	Parameter	Min	Max	Unit
$t_{w(NE)}$	FSMC_NE low time	$3 \cdot T_{HCLK} - 1.5$	$3 \cdot T_{HCLK} + 1$	ns
$t_{v(NOE\_NE)}$	FSMC_NEx low to FSMC_NOE low	$2 \cdot T_{HCLK} - 1$	$2 \cdot T_{HCLK}$	ns
$t_{w(NOE)}$	FSMC_NOE low time	$T_{HCLK} - 0.5$	$T_{HCLK} + 0.5$	ns
$t_{h(NE\_NOE)}$	FSMC_NOE high to FSMC_NE high hold time	0	-	ns
$t_{v(A\_NE)}$	FSMC_NEx low to FSMC_A valid	-	5	ns
$t_{v(NADV\_NE)}$	FSMC_NEx low to FSMC_NADV low	1.5	2	ns
$t_{w(NADV)}$	FSMC_NADV low time	$T_{HCLK} - 0.5$	$T_{HCLK}$	ns
$t_{h(AD\_NADV)}$	FSMC_AD(address) valid hold time after FSMC_NADV high	$T_{HCLK} - 6$	-	ns
$t_{h(A\_NOE)}$	Address hold time after FSMC_NOE high	$2 \cdot T_{HCLK} - 1$	-	ns
$t_{h(BL\_NOE)}$	FSMC_BL time after FSMC_NOE high	1.5	-	ns
$t_{v(BL\_NE)}$	FSMC_NEx low to FSMC_BL valid	-	0	ns
$t_{su(Data\_NE)}$	Data to FSMC_NEx high setup time	$T_{HCLK}$	-	ns
$t_{su(Data\_NOE)}$	Data to FSMC_NOE high setup time	$T_{HCLK}$	-	ns
$t_{h(Data\_NE)}$	Data hold time after FSMC_NEx high	0	-	ns
$t_{h(Data\_NOE)}$	Data hold time after FSMC_NOE high	0	-	ns

1.  $C_L = 30$  pF.

Figure 21. Asynchronous multiplexed PSRAM/NOR write waveforms



ai14891B

Table 39. Asynchronous multiplexed PSRAM/NOR write timings<sup>(1)</sup>

Symbol	Parameter	Min	Max	Unit
$t_{w(NE)}$	FSMC_NE low time	$4 \cdot T_{HCLK} - 3$	$4 \cdot T_{HCLK} + 2$	ns
$t_{v(NWE\_NE)}$	FSMC_NEx low to FSMC_NWE low	$T_{HCLK}$	$T_{HCLK} + 1$	ns
$t_{w(NWE)}$	FSMC_NWE low time	$2 \cdot T_{HCLK} - 2$	$2 \cdot T_{HCLK} + 4$	ns
$t_{h(NE\_NWE)}$	FSMC_NWE high to FSMC_NE high hold time	$T_{HCLK} - 2.5$	-	ns
$t_{v(A\_NE)}$	FSMC_NEx low to FSMC_A valid	-	6	ns
$t_{v(NADV\_NE)}$	FSMC_NEx low to FSMC_NADV low	1.5	2	ns
$t_{w(NADV)}$	FSMC_NADV low time	$T_{HCLK} - 4$	$T_{HCLK} + 4$	ns
$t_{h(AD\_NADV)}$	FSMC_AD (address) valid hold time after FSMC_NADV high	$T_{HCLK} - 5$	-	ns
$t_{h(A\_NWE)}$	Address hold time after FSMC_NWE high	$T_{HCLK} - 2.5$	-	ns
$t_{h(BL\_NWE)}$	FSMC_BL hold time after FSMC_NWE high	$T_{HCLK} - 3$	-	ns
$t_{v(BL\_NE)}$	FSMC_NEx low to FSMC_BL valid	-	0.5	ns
$t_{v(Data\_NADV)}$	FSMC_NADV high to Data valid	-	$T_{HCLK} + 6$	ns
$t_{h(Data\_NWE)}$	Data hold time after FSMC_NWE high	$T_{HCLK} - 2.5$	-	ns

1.  $C_L = 30$  pF.



Table 40. Synchronous multiplexed NOR/PSRAM read timings<sup>(1)</sup>

Symbol	Parameter	Min	Max	Unit
$t_{w(\text{CLK})}$	FSMC_CLK period	$2 \cdot T_{\text{HCLK}} - 0.5$	-	ns
$t_{d(\text{CLKL-NExL})}$	FSMC_CLK low to FSMC_NEx low (x = 0...2)	-	0	ns
$t_{d(\text{CLKL-NExH})}$	FSMC_CLK low to FSMC_NEx high (x = 0...2)	$T_{\text{HCLK}} + 1.5$	-	ns
$t_{d(\text{CLKL-NADV})}$	FSMC_CLK low to FSMC_NADV low	-	3	ns
$t_{d(\text{CLKL-NADVH})}$	FSMC_CLK low to FSMC_NADV high	3.5	-	ns
$t_{d(\text{CLKL-AV})}$	FSMC_CLK low to FSMC_Ax valid (x = 16...25)	-	0	ns
$t_{d(\text{CLKL-AIV})}$	FSMC_CLK low to FSMC_Ax invalid (x = 16...25)	0	-	ns
$t_{d(\text{CLKL-NOEL})}$	FSMC_CLK low to FSMC_NOE low	-	$T_{\text{HCLK}} - 1$	ns
$t_{d(\text{CLKL-NOEH})}$	FSMC_CLK low to FSMC_NOE high	2.5	-	ns
$t_{d(\text{CLKL-ADV})}$	FSMC_CLK low to FSMC_AD[15:0] valid	-	4	ns
$t_{d(\text{CLKL-ADIV})}$	FSMC_CLK low to FSMC_AD[15:0] invalid	0	-	ns
$t_{su(\text{ADV-CLKH})}$	FSMC_A/D[15:0] valid data before FSMC_CLK high	6	-	ns
$t_h(\text{CLKH-ADV})$	FSMC_A/D[15:0] valid data after FSMC_CLK high	4	-	ns
$t_{su(\text{NWAITV-CLKH})}$	FSMC_NWAIT valid before FSMC_CLK high	6	-	ns
$t_h(\text{CLKH-NWAITV})$	FSMC_NWAIT valid after FSMC_CLK high	0	-	ns

1.  $C_L = 30$  pF.

Figure 23. Synchronous multiplexed PSRAM write timings

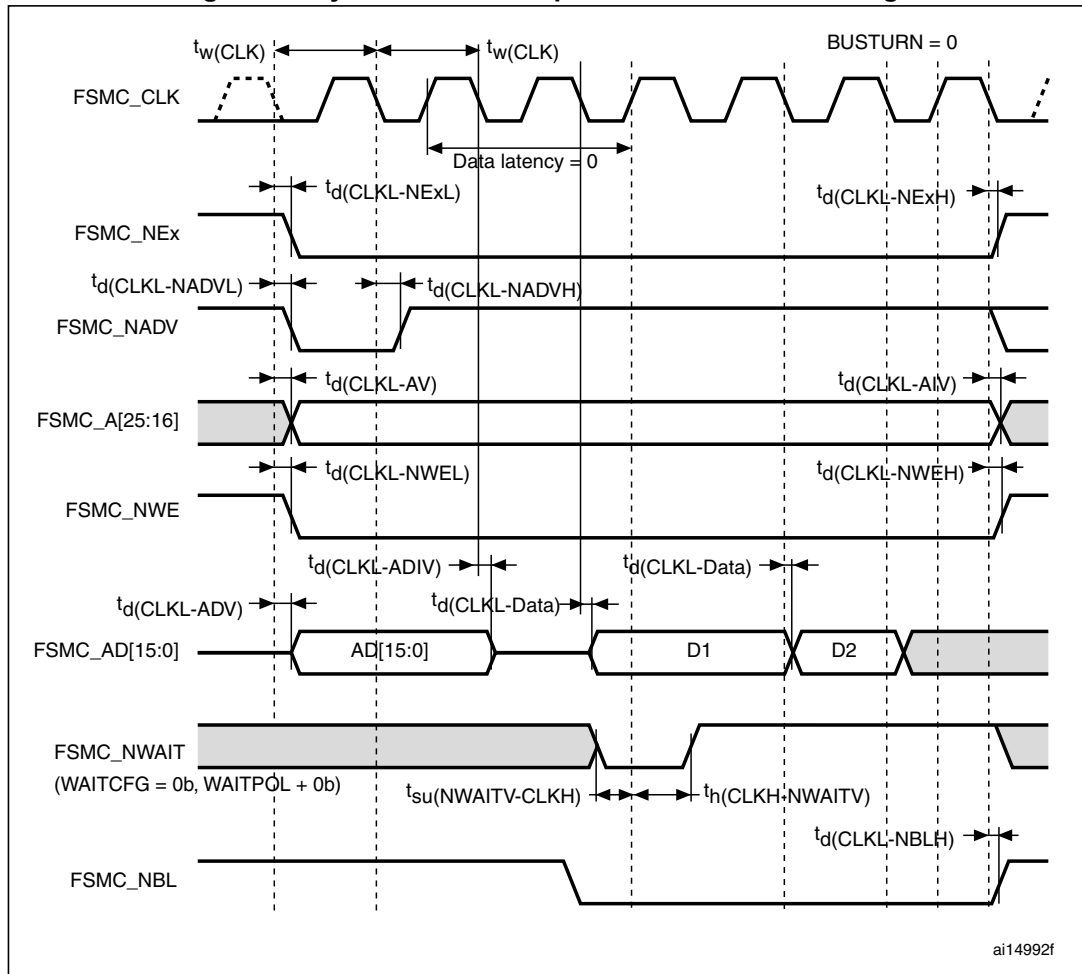

Table 41. Synchronous multiplexed PSRAM write timings<sup>(1)</sup>

Symbol	Parameter	Min	Max	Unit
$t_{w(\text{CLK})}$	FSMC_CLK period	$2 \cdot T_{\text{HCLK}}$	-	ns
$t_{d(\text{CLKL-NExL})}$	FSMC_CLK low to FSMC_NEx low (x = 0...2)	-	0	ns
$t_{d(\text{CLKL-NExH})}$	FSMC_CLK low to FSMC_NEx high (x = 0...2)	0	-	ns
$t_{d(\text{CLKL-NADV})}$	FSMC_CLK low to FSMC_NADV low	-	0	ns
$t_{d(\text{CLKL-NADVH})}$	FSMC_CLK low to FSMC_NADV high	0	-	ns
$t_{d(\text{CLKL-AV})}$	FSMC_CLK low to FSMC_Ax valid (x = 16...25)	-	0	ns
$t_{d(\text{CLKL-AIV})}$	FSMC_CLK low to FSMC_Ax invalid (x = 16...25)	$T_{\text{HCLK}} + 4$	-	ns
$t_{d(\text{CLKL-NWEL})}$	FSMC_CLK low to FSMC_NWE low	-	0	ns
$t_{d(\text{CLKL-NWEH})}$	FSMC_CLK low to FSMC_NWE high	1	-	ns
$t_{d(\text{CLKL-ADIV})}$	FSMC_CLK low to FSMC_AD[15:0] invalid	5	-	ns
$t_{d(\text{CLKL-DATA})}$	FSMC_A/D[15:0] valid after FSMC_CLK low	-	6	ns
$t_{su(\text{NWAITV-CLKH})}$	FSMC_NWAIT valid before FSMC_CLK high	6	-	ns
$t_{h(\text{CLKH-NWAITV})}$	FSMC_NWAIT valid after FSMC_CLK high	0	-	ns
$t_{d(\text{CLKL-NBLH})}$	FSMC_CLK low to FSMC_NBL high	1	-	ns

1.  $C_L = 30$  pF.

Figure 24. Synchronous non-multiplexed NOR/PSRAM read timings

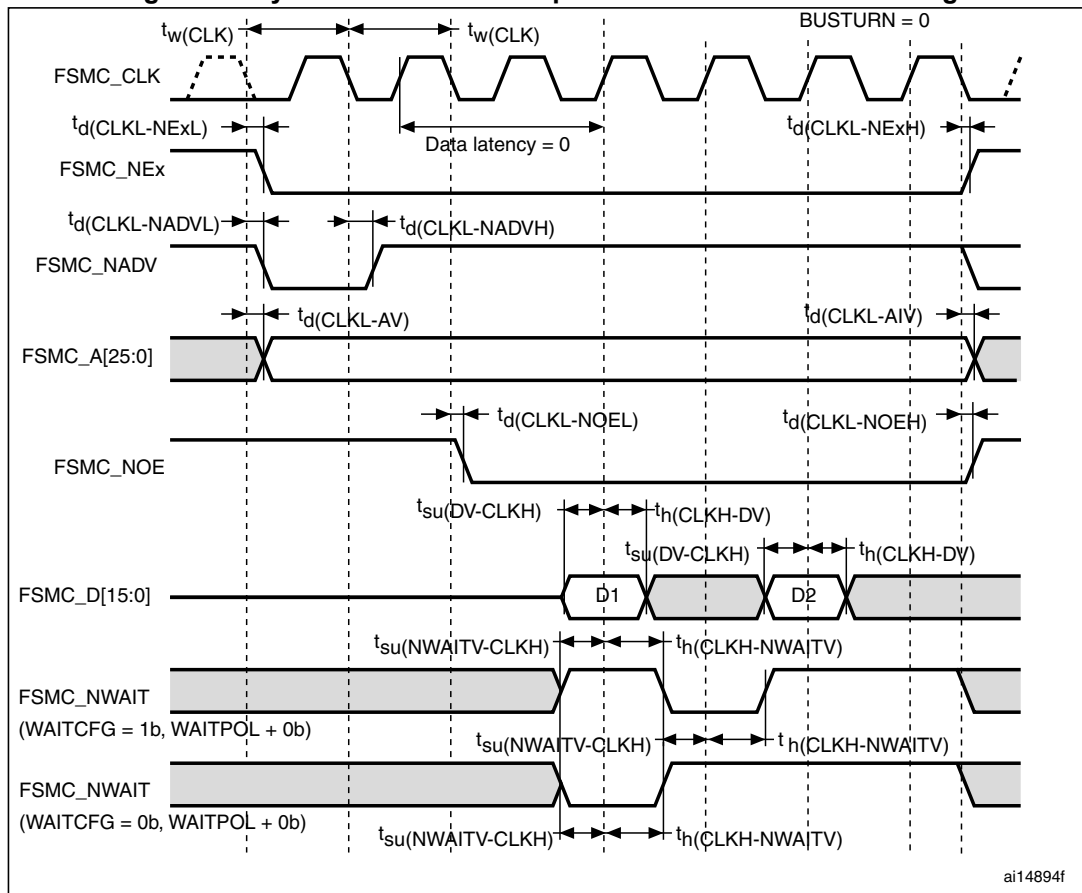

Table 42. Synchronous non-multiplexed NOR/PSRAM read timings<sup>(1)</sup>

Symbol	Parameter	Min	Max	Unit
$t_w(\text{CLK})$	FSMC_CLK period	$2 \cdot T_{\text{HCLK}} - 0.5$	-	ns
$t_d(\text{CLKL-NExL})$	FSMC_CLK low to FSMC_NEx low ( $x = 0 \dots 2$ )	-	0	ns
$t_d(\text{CLKL-NExH})$	FSMC_CLK low to FSMC_NEx high ( $x = 0 \dots 2$ )	0	-	ns
$t_d(\text{CLKL-NADV})$	FSMC_CLK low to FSMC_NADV low	-	3	ns
$t_d(\text{CLKL-NADVH})$	FSMC_CLK low to FSMC_NADV high	3.5	-	ns
$t_d(\text{CLKL-AV})$	FSMC_CLK low to FSMC_Ax valid ( $x = 16 \dots 25$ )	-	0	ns
$t_d(\text{CLKL-AIV})$	FSMC_CLK low to FSMC_Ax invalid ( $x = 16 \dots 25$ )	0	-	ns
$t_d(\text{CLKL-NOEL})$	FSMC_CLK low to FSMC_NOE low	-	$T_{\text{HCLK}} + 1$	ns
$t_d(\text{CLKL-NOEH})$	FSMC_CLK low to FSMC_NOE high	2.5	-	ns
$t_{su}(\text{DV-CLKH})$	FSMC_D[15:0] valid data before FSMC_CLK high	4	-	ns
$t_h(\text{CLKH-DV})$	FSMC_D[15:0] valid data after FSMC_CLK high	4	-	ns



**Table 43. Synchronous non-multiplexed PSRAM write timings<sup>(1)</sup> (continued)**

Symbol	Parameter	Min	Max	Unit
$t_{d(\text{CLKL-NWEH})}$	FSMC_CLK low to FSMC_NWE high	5	-	ns
$t_{d(\text{CLKL-DATA})}$	FSMC_D[15:0] valid data after FSMC_CLK low	-	7	ns
$t_{d(\text{CLKL-NBLH})}$	FSMC_CLK low to FSMC_NBL high	3	-	ns
$t_{su(\text{NWAITV-CLKH})}$	FSMC_NWAIT valid before FSMC_CLK high	6	-	ns
$t_{h(\text{CLKH-NWAITV})}$	FSMC_NWAIT valid after FSMC_CLK high	0	-	ns

1.  $C_L = 30$  pF.

### 6.3.11 EMC characteristics

Susceptibility tests are performed on a sample basis during device characterization.

#### Functional EMS (electromagnetic susceptibility)

While a simple application is executed on the device (toggling 2 LEDs through I/O ports), the device is stressed by two electromagnetic events until a failure occurs. The failure is indicated by the LEDs:

- **Electrostatic discharge (ESD)** (positive and negative) is applied to all device pins until a functional disturbance occurs. This test is compliant with the IEC 61000-4-2 standard.
- **FTB:** A Burst of Fast Transient voltage (positive and negative) is applied to  $V_{DD}$  and  $V_{SS}$  through a 100 pF capacitor, until a functional disturbance occurs. This test is compliant with the IEC 61000-4-4 standard.

A device reset allows normal operations to be resumed.

The test results are given in [Table 44](#). They are based on the EMS levels and classes defined in application note AN1709.

**Table 44. EMS characteristics**

Symbol	Parameter	Conditions	Level/Class
$V_{FESD}$	Voltage limits to be applied on any I/O pin to induce a functional disturbance	$V_{DD} = 3.3\text{ V}$ , LQFP100, $T_A = +25\text{ }^\circ\text{C}$ , $f_{HCLK} = 32\text{ MHz}$ conforms to IEC 61000-4-2	2B
$V_{EFTB}$	Fast transient voltage burst limits to be applied through 100 pF on $V_{DD}$ and $V_{SS}$ pins to induce a functional disturbance	$V_{DD} = 3.3\text{ V}$ , LQFP100, $T_A = +25\text{ }^\circ\text{C}$ , $f_{HCLK} = 32\text{ MHz}$ conforms to IEC 61000-4-4	4A

#### Designing hardened software to avoid noise problems

EMC characterization and optimization are performed at component level with a typical application environment and simplified MCU software. It should be noted that good EMC performance is highly dependent on the user application and the software in particular.

Therefore it is recommended that the user applies EMC software optimization and prequalification tests in relation with the EMC level requested for his application.

##### Software recommendations

The software flowchart must include the management of runaway conditions such as:

- Corrupted program counter
- Unexpected reset
- Critical data corruption (control registers...)

##### Prequalification trials

Most of the common failures (unexpected reset and program counter corruption) can be reproduced by manually forcing a low state on the NRST pin or the oscillator pins for 1 second.

To complete these trials, ESD stress can be applied directly on the device, over the range of specification values. When unexpected behavior is detected, the software can be hardened to prevent unrecoverable errors occurring (see application note AN1015).

**Electromagnetic Interference (EMI)**

The electromagnetic field emitted by the device are monitored while a simple application is executed (toggling 2 LEDs through the I/O ports). This emission test is compliant with IEC 61967-2 standard which specifies the test board and the pin loading.

**Table 45. EMI characteristics**

Symbol	Parameter	Conditions	Monitored frequency band	Max vs. frequency range			Unit
				4 MHz voltage range 3	16 MHz voltage range 2	32 MHz voltage range 1	
S <sub>EMI</sub>	Peak level	V <sub>DD</sub> = 3.3 V, T <sub>A</sub> = 25 °C, LQFP100 package compliant with IEC 61967-2	0.1 to 30 MHz	3	-6	-5	dBµV
			30 to 130 MHz	18	4	-7	
			130 MHz to 1GHz	15	5	-7	
			SAE EMI Level	2.5	2	1	-

**6.3.12 Electrical sensitivity characteristics**

Based on three different tests (ESD, LU) using specific measurement methods, the device is stressed in order to determine its performance in terms of electrical sensitivity.

**Electrostatic discharge (ESD)**

Electrostatic discharges (a positive then a negative pulse separated by 1 second) are applied to the pins of each sample according to each pin combination. The sample size depends on the number of supply pins in the device (3 parts × (n+1) supply pins). This test conforms to the JESD22-A114/C101 standard.

**Table 46. ESD absolute maximum ratings**

Symbol	Ratings	Conditions	Class	Maximum value <sup>(1)</sup>	Unit
V <sub>ESD(HBM)</sub>	Electrostatic discharge voltage (human body model)	T <sub>A</sub> = +25 °C, conforming to JESD22-A114	2	2000	V
V <sub>ESD(CDM)</sub>	Electrostatic discharge voltage (charge device model)	T <sub>A</sub> = +25 °C, conforming to ANSI/ESD STM5.3.1.	II	500	V

1. Guaranteed by characterization results, not tested in production.

**Static latch-up**

Two complementary static tests are required on six parts to assess the latch-up performance:

- A supply overvoltage is applied to each power supply pin
- A current injection is applied to each input, output and configurable I/O pin

These tests are compliant with EIA/JESD 78A IC latch-up standard.

**Table 47. Electrical sensitivities**

Symbol	Parameter	Conditions	Class
LU	Static latch-up class	T <sub>A</sub> = +105 °C conforming to JESD78A	II level A

**6.3.13 I/O current injection characteristics**

As a general rule, current injection to the I/O pins, due to external voltage below V<sub>SS</sub> or above V<sub>DD</sub> (for standard pins) should be avoided during normal product operation. However, in order to give an indication of the robustness of the microcontroller in cases when abnormal injection accidentally happens, susceptibility tests are performed on a sample basis during device characterization.

**Functional susceptibility to I/O current injection**

While a simple application is executed on the device, the device is stressed by injecting current into the I/O pins programmed in floating input mode. While current is injected into the I/O pin, one at a time, the device is checked for functional failures.

The failure is indicated by an out of range parameter: ADC error above a certain limit (higher than 5 LSB TUE), out of conventional limits of induced leakage current on adjacent pins (out of -5 µA/+0 µA range), or other functional failure (for example reset occurrence oscillator frequency deviation, LCD levels).

The test results are given in the [Table 48](#).

**Table 48. I/O current injection susceptibility**

Symbol	Description	Functional susceptibility		Unit
		Negative injection	Positive injection	
I <sub>INJ</sub>	Injected current on all 5 V tolerant (FT) pins	-5 <sup>(1)</sup>	NA	mA
	Injected current on BOOT0	-0	NA	
	Injected current on any other pin	-5 <sup>(1)</sup>	+5	

1. It is recommended to add a Schottky diode (pin to ground) to analog pins which may potentially inject negative currents.

### 6.3.14 I/O port characteristics

#### General input/output characteristics

Unless otherwise specified, the parameters given in [Table 55](#) are derived from tests performed under the conditions summarized in [Table 12](#). All I/Os are CMOS and TTL compliant.

**Table 49. I/O static characteristics**

Symbol	Parameter	Conditions	Min	Typ	Max	Unit
$V_{IL}$	Input low level voltage		-	-	$0.3V_{DD}^{(1)}$	V
$V_{IH}$	Input high level voltage	Standard I/O	$0.7 V_{DD}$	-	-	
		FT I/O		-	-	
		BOOT0 I/O		-	-	
$V_{hys}$	I/O Schmitt trigger voltage hysteresis <sup>(2)</sup>	Standard I/O	-	$10\% V_{DD}^{(3)}$	-	
$I_{lkg}$	Input leakage current <sup>(4)</sup>	$V_{SS} \leq V_{IN} \leq V_{DD}$ I/Os with LCD	-	-	$\pm 50$	nA
		$V_{SS} \leq V_{IN} \leq V_{DD}$ I/Os with analog switches	-	-	$\pm 50$	
		$V_{SS} \leq V_{IN} \leq V_{DD}$ I/Os with analog switches and LCD	-	-	$\pm 50$	
		$V_{SS} \leq V_{IN} \leq V_{DD}$ I/Os with USB	-	-	$\pm 250$	
		$V_{SS} \leq V_{IN} \leq V_{DD}$ Standard I/Os	-	-	$\pm 50$	
		FT I/O $V_{DD} \leq V_{IN} \leq 5V$	-	-	$\pm 10$	$\mu A$
$R_{PU}$	Weak pull-up equivalent resistor <sup>(1)(5)</sup>	$V_{IN} = V_{SS}$	30	45	60	k $\Omega$
$R_{PD}$	Weak pull-down equivalent resistor <sup>(5)</sup>	$V_{IN} = V_{DD}$	30	45	60	k $\Omega$
$C_{IO}$	I/O pin capacitance	-	-	5	-	pF

1. Guaranteed by test in production
2. Hysteresis voltage between Schmitt trigger switching levels. Guaranteed by characterization results, not tested in production.
3. With a minimum of 200 mV. Based on characterization, not tested in production.
4. The max. value may be exceeded if negative current is injected on adjacent pins.
5. Pull-up and pull-down resistors are designed with a true resistance in series with a switchable PMOS/NMOS.

### Output driving current

The GPIOs (general purpose input/outputs) can sink or source up to  $\pm 8$  mA, and sink or source up to  $\pm 20$  mA with the non-standard  $V_{OL}/V_{OH}$  specifications given in [Table 50](#).

In the user application, the number of I/O pins which can drive current must be limited to respect the absolute maximum rating specified in [Section 6.2](#):

- The sum of the currents sourced by all the I/Os on  $V_{DD}$ , plus the maximum Run consumption of the MCU sourced on  $V_{DD}$ , cannot exceed the absolute maximum rating  $I_{VDD(\Sigma)}$  (see [Table 10](#)).
- The sum of the currents sunk by all the I/Os on  $V_{SS}$  plus the maximum Run consumption of the MCU sunk on  $V_{SS}$  cannot exceed the absolute maximum rating  $I_{VSS(\Sigma)}$  (see [Table 10](#)).

### Output voltage levels

Unless otherwise specified, the parameters given in [Table 50](#) are derived from tests performed under the conditions summarized in [Table 12](#). All I/Os are CMOS and TTL compliant.

**Table 50. Output voltage characteristics**

Symbol	Parameter	Conditions	Min	Max	Unit
$V_{OL}^{(1)(2)}$	Output low level voltage for an I/O pin	$I_{IO} = 8$ mA $2.7$ V < $V_{DD} < 3.6$ V	-	0.4	V
$V_{OH}^{(2)(3)}$	Output high level voltage for an I/O pin		$V_{DD}-0.4$	-	
$V_{OL}^{(3)(4)}$	Output low level voltage for an I/O pin	$I_{IO} = 4$ mA $1.65$ V < $V_{DD} < 3.6$ V	-	0.45	
$V_{OH}^{(3)(4)}$	Output high level voltage for an I/O pin		$V_{DD}-0.45$	-	
$V_{OL}^{(1)(4)}$	Output low level voltage for an I/O pin	$I_{IO} = 20$ mA $2.7$ V < $V_{DD} < 3.6$ V	-	1.3	
$V_{OH}^{(3)(4)}$	Output high level voltage for an I/O pin		$V_{DD}-1.3$	-	

1. The  $I_{IO}$  current sunk by the device must always respect the absolute maximum rating specified in [Table 10](#) and the sum of  $I_{IO}$  (I/O ports and control pins) must not exceed  $I_{VSS}$ .
2. Guaranteed by test in production.
3. The  $I_{IO}$  current sourced by the device must always respect the absolute maximum rating specified in [Table 10](#) and the sum of  $I_{IO}$  (I/O ports and control pins) must not exceed  $I_{VDD}$ .
4. Guaranteed by characterization results, not tested in production.

### Input/output AC characteristics

The definition and values of input/output AC characteristics are given in [Figure 26](#) and [Table 51](#), respectively.

Unless otherwise specified, the parameters given in [Table 51](#) are derived from tests performed under the conditions summarized in [Table 12](#).

**Table 51. I/O AC characteristics<sup>(1)</sup>**

OSPEEDRx [1:0] bit value <sup>(1)</sup>	Symbol	Parameter	Conditions	Min	Max <sup>(2)</sup>	Unit
00	$f_{\max(\text{IO})\text{out}}$	Maximum frequency <sup>(3)</sup>	$C_L = 50 \text{ pF}, V_{DD} = 2.7 \text{ V to } 3.6 \text{ V}$	-	400	kHz
			$C_L = 50 \text{ pF}, V_{DD} = 1.65 \text{ V to } 2.7 \text{ V}$	-	400	
	$t_{f(\text{IO})\text{out}}$ $t_{r(\text{IO})\text{out}}$	Output rise and fall time	$C_L = 50 \text{ pF}, V_{DD} = 2.7 \text{ V to } 3.6 \text{ V}$	-	625	ns
			$C_L = 50 \text{ pF}, V_{DD} = 1.65 \text{ V to } 2.7 \text{ V}$	-	625	
01	$f_{\max(\text{IO})\text{out}}$	Maximum frequency <sup>(3)</sup>	$C_L = 50 \text{ pF}, V_{DD} = 2.7 \text{ V to } 3.6 \text{ V}$	-	2	MHz
			$C_L = 50 \text{ pF}, V_{DD} = 1.65 \text{ V to } 2.7 \text{ V}$	-	1	
	$t_{f(\text{IO})\text{out}}$ $t_{r(\text{IO})\text{out}}$	Output rise and fall time	$C_L = 50 \text{ pF}, V_{DD} = 2.7 \text{ V to } 3.6 \text{ V}$	-	125	ns
			$C_L = 50 \text{ pF}, V_{DD} = 1.65 \text{ V to } 2.7 \text{ V}$	-	250	
10	$F_{\max(\text{IO})\text{out}}$	Maximum frequency <sup>(3)</sup>	$C_L = 50 \text{ pF}, V_{DD} = 2.7 \text{ V to } 3.6 \text{ V}$	-	10	MHz
			$C_L = 50 \text{ pF}, V_{DD} = 1.65 \text{ V to } 2.7 \text{ V}$	-	2	
	$t_{f(\text{IO})\text{out}}$ $t_{r(\text{IO})\text{out}}$	Output rise and fall time	$C_L = 50 \text{ pF}, V_{DD} = 2.7 \text{ V to } 3.6 \text{ V}$	-	25	ns
			$C_L = 50 \text{ pF}, V_{DD} = 1.65 \text{ V to } 2.7 \text{ V}$	-	125	
11	$F_{\max(\text{IO})\text{out}}$	Maximum frequency <sup>(3)</sup>	$C_L = 30 \text{ pF}, V_{DD} = 2.7 \text{ V to } 3.6 \text{ V}$	-	50	MHz
			$C_L = 50 \text{ pF}, V_{DD} = 1.65 \text{ V to } 2.7 \text{ V}$	-	8	
	$t_{f(\text{IO})\text{out}}$ $t_{r(\text{IO})\text{out}}$	Output rise and fall time	$C_L = 30 \text{ pF}, V_{DD} = 2.7 \text{ V to } 3.6 \text{ V}$	-	5	ns
			$C_L = 50 \text{ pF}, V_{DD} = 1.65 \text{ V to } 2.7 \text{ V}$	-	30	
-	$t_{\text{EXTI}pw}$	Pulse width of external signals detected by the EXTI controller	-	8	-	ns

1. The I/O speed is configured using the OSPEEDRx[1:0] bits. Refer to the STM32L151xx, STM32L152xx and STM32L162xx reference manual for a description of GPIO Port configuration register.

2. Guaranteed by design, not tested in production.

3. The maximum frequency is defined in [Figure 26](#).

Figure 26. I/O AC characteristics definition

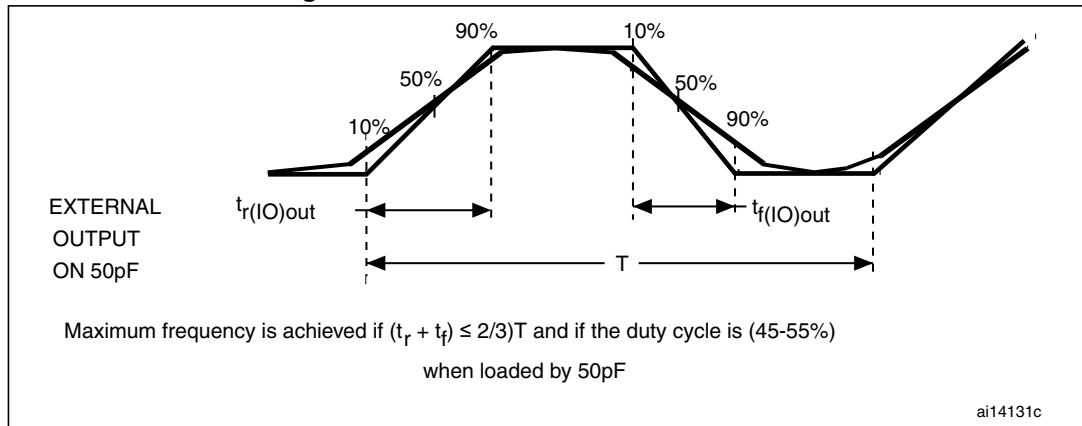

### 6.3.15 NRST pin characteristics

The NRST pin input driver uses CMOS technology. It is connected to a permanent pull-up resistor,  $R_{PU}$  (see [Table 52](#))

Unless otherwise specified, the parameters given in [Table 52](#) are derived from tests performed under the conditions summarized in [Table 12](#).

Table 52. NRST pin characteristics

Symbol	Parameter	Conditions	Min	Typ	Max	Unit
$V_{IL(NRST)}^{(1)}$	NRST input low level voltage	-	-	-	$0.3 V_{DD}$	V
$V_{IH(NRST)}^{(1)}$	NRST input high level voltage	-	$0.7 V_{DD}$	-	-	
$V_{OL(NRST)}^{(1)}$	NRST output low level voltage	$I_{OL} = 2 \text{ mA}$ $2.7 \text{ V} < V_{DD} < 3.6 \text{ V}$	-	-	0.4	
		$I_{OL} = 1.5 \text{ mA}$ $1.65 \text{ V} < V_{DD} < 2.7 \text{ V}$	-	-		
$V_{hys(NRST)}^{(1)}$	NRST Schmitt trigger voltage hysteresis	-	-	$10\% V_{DD}^{(2)}$	-	mV
$R_{PU}$	Weak pull-up equivalent resistor <sup>(3)</sup>	$V_{IN} = V_{SS}$	30	45	60	k $\Omega$
$V_F(NRST)^{(1)}$	NRST input filtered pulse	-	-	-	50	ns
$V_{NF(NRST)}^{(3)}$	NRST input not filtered pulse	-	350	-	-	ns

1. Guaranteed by design, not tested in production.
2. With a minimum of 200 mV.
3. The pull-up is designed with a true resistance in series with a switchable PMOS. This PMOS contribution to the series resistance is around 10%.

Figure 27. Recommended NRST pin protection

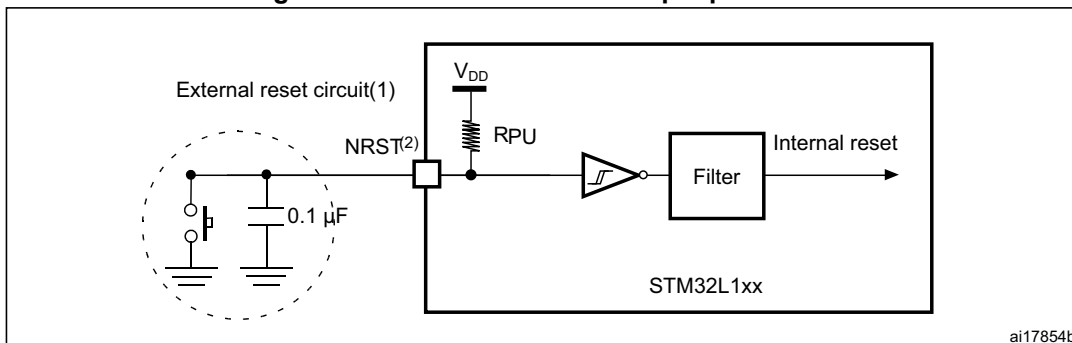

1. The reset network protects the device against parasitic resets.
2. The user must ensure that the level on the NRST pin can go below the  $V_{IL(NRST)}$  max level specified in [Table 52](#). Otherwise the reset will not be taken into account by the device.

### 6.3.16 TIM timer characteristics

The parameters given in the [Table 53](#) are guaranteed by design.

Refer to [Section 6.3.14: I/O port characteristics](#) for details on the input/output cation characteristics (output compare, input capture, external clock, PWM output).

Table 53. TIMx<sup>(1)</sup> characteristics

Symbol	Parameter	Conditions	Min	Max	Unit
$t_{res(TIM)}$	Timer resolution time		1	-	$t_{TIMxCLK}$
		$f_{TIMxCLK} = 32 \text{ MHz}$	31.25	-	ns
$f_{EXT}$	Timer external clock frequency on CH1 to CH4		0	$f_{TIMxCLK}/2$	MHz
		$f_{TIMxCLK} = 32 \text{ MHz}$	0	16	MHz
$Res_{TIM}$	Timer resolution	-		16	bit
$t_{COUNTER}$	16-bit counter clock period when internal clock is selected (timer's prescaler disabled)		1	65536	$t_{TIMxCLK}$
		$f_{TIMxCLK} = 32 \text{ MHz}$	0.0312	2048	$\mu\text{s}$
$t_{MAX\_COUNT}$	Maximum possible count		-	$65536 \times 65536$	$t_{TIMxCLK}$
		$f_{TIMxCLK} = 32 \text{ MHz}$	-	134.2	s

1. TIMx is used as a general term to refer to the TIM2, TIM3 and TIM4 timers.

### 6.3.17 Communications interfaces

#### I<sup>2</sup>C interface characteristics

The device I<sup>2</sup>C interface meets the requirements of the standard I<sup>2</sup>C communication protocol with the following restrictions: SDA and SCL are not “true” open-drain I/O pins. When configured as open-drain, the PMOS connected between the I/O pin and V<sub>DD</sub> is disabled, but is still present.

The I<sup>2</sup>C characteristics are described in [Table 54](#). Refer also to [Section 6.3.14: I/O port characteristics](#) for more details on the input/output cation characteristics (SDA and SCL).

**Table 54. I<sup>2</sup>C characteristics**

Symbol	Parameter	Standard mode I <sup>2</sup> C <sup>(1)(2)</sup>		Fast mode I <sup>2</sup> C <sup>(1)(2)</sup>		Unit
		Min	Max	Min	Max	
t <sub>w</sub> (SCLL)	SCL clock low time	4.7	-	1.3	-	μs
t <sub>w</sub> (SCLH)	SCL clock high time	4.0	-	0.6	-	
t <sub>su</sub> (SDA)	SDA setup time	250	-	100	-	ns
t <sub>h</sub> (SDA)	SDA data hold time	-	3450 <sup>(3)</sup>	-	900 <sup>(3)</sup>	
t <sub>r</sub> (SDA) t <sub>r</sub> (SCL)	SDA and SCL rise time	-	1000	-	300	
t <sub>f</sub> (SDA) t <sub>f</sub> (SCL)	SDA and SCL fall time	-	300	-	300	
t <sub>h</sub> (STA)	Start condition hold time	4.0	-	0.6	-	μs
t <sub>su</sub> (STA)	Repeated Start condition setup time	4.7	-	0.6	-	
t <sub>su</sub> (STO)	Stop condition setup time	4.0	-	0.6	-	μs
t <sub>w</sub> (STO:STA)	Stop to Start condition time (bus free)	4.7	-	1.3	-	μs
C <sub>b</sub>	Capacitive load for each bus line	-	400	-	400	pF
t <sub>SP</sub>	Pulse width of spikes that are suppressed by the analog filter	0	50 <sup>(4)</sup>	0	50 <sup>(4)</sup>	ns

1. Guaranteed by design, not tested in production.
2. f<sub>PCLK1</sub> must be at least 2 MHz to achieve standard mode I<sup>2</sup>C frequencies. It must be at least 4 MHz to achieve fast mode I<sup>2</sup>C frequencies. It must be a multiple of 10 MHz to reach the 400 kHz maximum I<sup>2</sup>C fast mode clock.
3. The maximum Data hold time has only to be met if the interface does not stretch the low period of SCL signal.
4. The minimum width of the spikes filtered by the analog filter is above t<sub>SP(max)</sub>.

Figure 28. I<sup>2</sup>C bus AC waveforms and measurement circuit

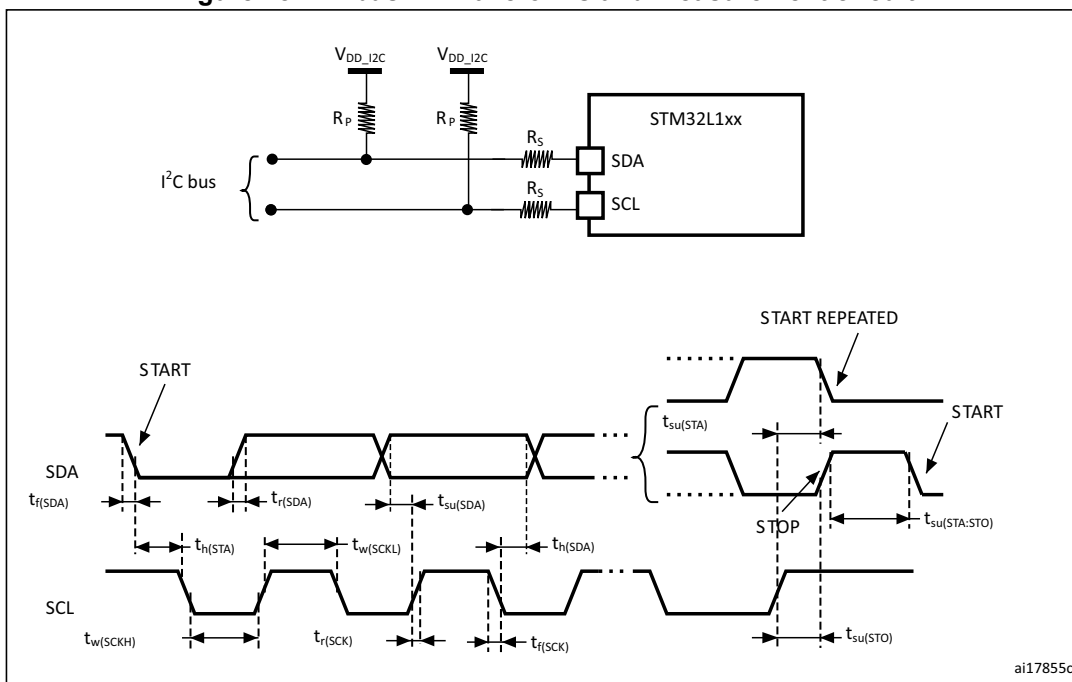

1.  $R_S$  = series protection resistor.
2.  $R_P$  = external pull-up resistor.
3.  $V_{DD\_I2C}$  is the I2C bus power supply.
4. Measurement points are done at CMOS levels:  $0.3V_{DD}$  and  $0.7V_{DD}$ .

Table 55. SCL frequency ( $f_{PCLK1} = 32\text{ MHz}$ ,  $V_{DD} = V_{DD\_I2C} = 3.3\text{ V}$ )<sup>(1)(2)</sup>

$f_{SCL}$ (kHz)	I2C_CCR value
	$R_P = 4.7\text{ k}\Omega$
400	0x801B
300	0x8024
200	0x8035
100	0x00A0
50	0x0140
20	0x0320

1.  $R_P$  = External pull-up resistance,  $f_{SCL}$  = I<sup>2</sup>C speed.
2. For speeds around 200 kHz, the tolerance on the achieved speed is of  $\pm 5\%$ . For other speed ranges, the tolerance on the achieved speed is  $\pm 2\%$ . These variations depend on the accuracy of the external components used to design the application.

**SPI characteristics**

Unless otherwise specified, the parameters given in the following table are derived from tests performed under the conditions summarized in [Table 12](#).

Refer to [Section 6.3.13: I/O current injection characteristics](#) for more details on the input/output alternate function characteristics (NSS, SCK, MOSI, MISO).

**Table 56. SPI characteristics<sup>(1)</sup>**

Symbol	Parameter	Conditions	Min	Max <sup>(2)</sup>	Unit
$f_{SCK}$ $1/t_{c(SCK)}$	SPI clock frequency	Master mode	-	16	MHz
		Slave mode	-	16	
		Slave transmitter	-	12 <sup>(3)</sup>	
$t_{r(SCK)}^{(2)}$ $t_{f(SCK)}^{(2)}$	SPI clock rise and fall time	Capacitive load: C = 30 pF	-	6	ns
DuCy(SCK)	SPI slave input clock duty cycle	Slave mode	30	70	%
$t_{su(NSS)}$	NSS setup time	Slave mode	$4t_{HCLK}$	-	ns
$t_{h(NSS)}$	NSS hold time	Slave mode	$2t_{HCLK}$	-	
$t_{w(SCKH)}^{(2)}$ $t_{w(SCKL)}^{(2)}$	SCK high and low time	Master mode	$t_{SCK}/2-5$	$t_{SCK}/2+3$	
$t_{su(MI)}^{(2)}$	Data input setup time	Master mode	5	-	
$t_{su(SI)}^{(2)}$		Slave mode	6	-	
$t_{h(MI)}^{(2)}$	Data input hold time	Master mode	5	-	
$t_{h(SI)}^{(2)}$		Slave mode	5	-	
$t_{a(SO)}^{(4)}$	Data output access time	Slave mode	0	$3t_{HCLK}$	
$t_{v(SO)}^{(2)}$	Data output valid time	Slave mode	-	33	
$t_{v(MO)}^{(2)}$	Data output valid time	Master mode	-	6.5	
$t_{h(SO)}^{(2)}$	Data output hold time	Slave mode	17	-	
$t_{h(MO)}^{(2)}$		Master mode	0.5	-	

1. The characteristics above are given for voltage range 1.
2. Guaranteed by characterization results, not tested in production.
3. The maximum SPI clock frequency in slave transmitter mode is given for an SPI slave input clock duty cycle (DuCy(SCK)) ranging between 40 to 60%.
4. Min time is for the minimum time to drive the output and max time is for the maximum time to validate the data.

Figure 29. SPI timing diagram - slave mode and CPHA = 0

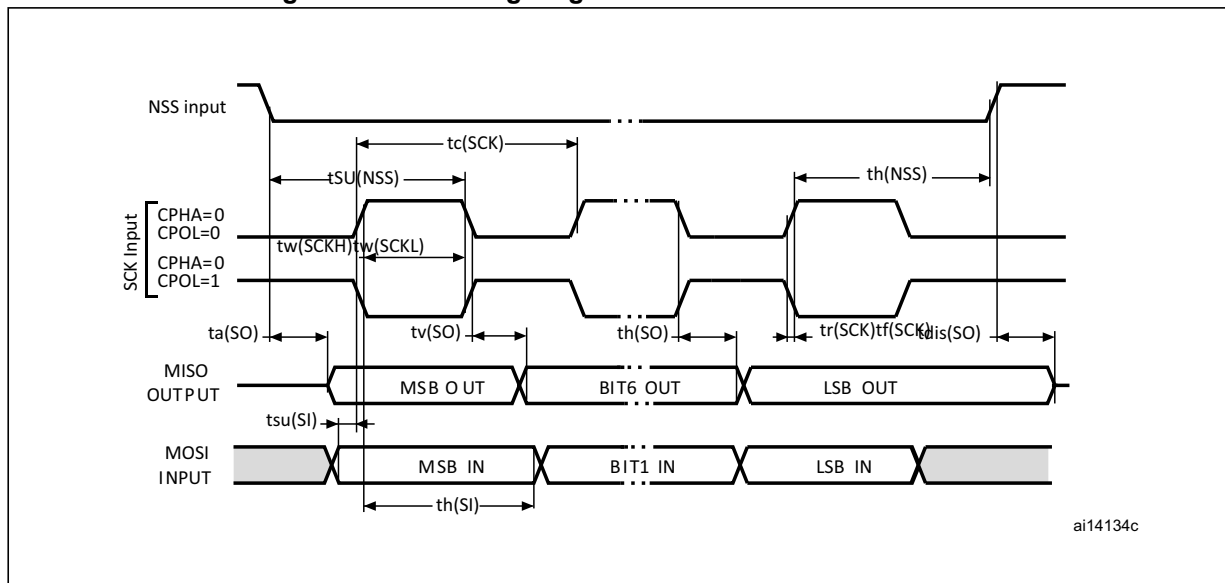
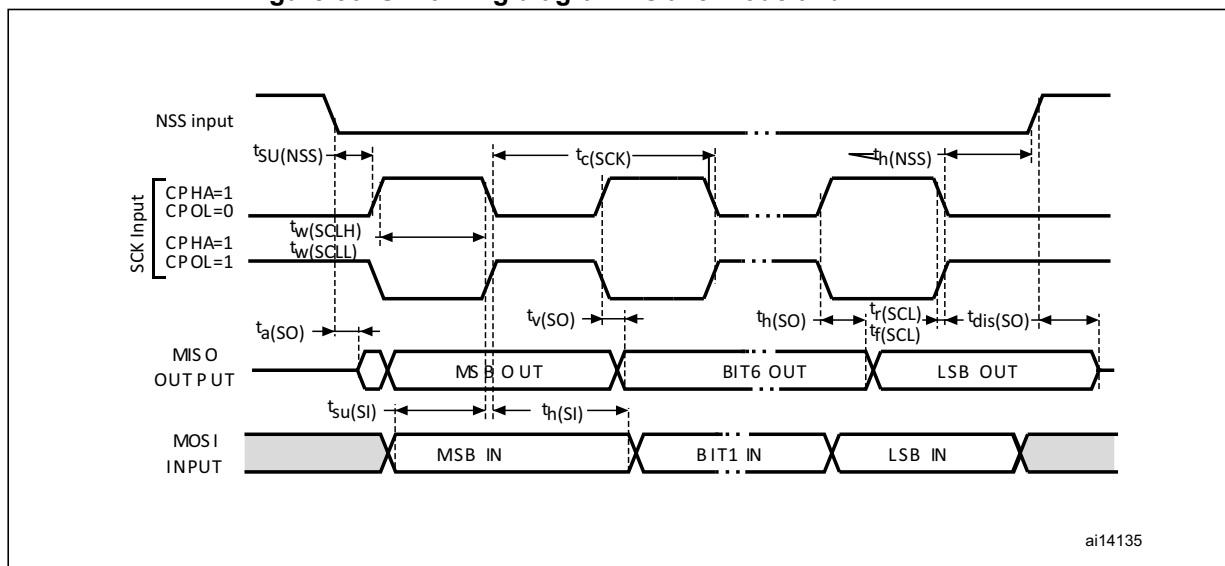
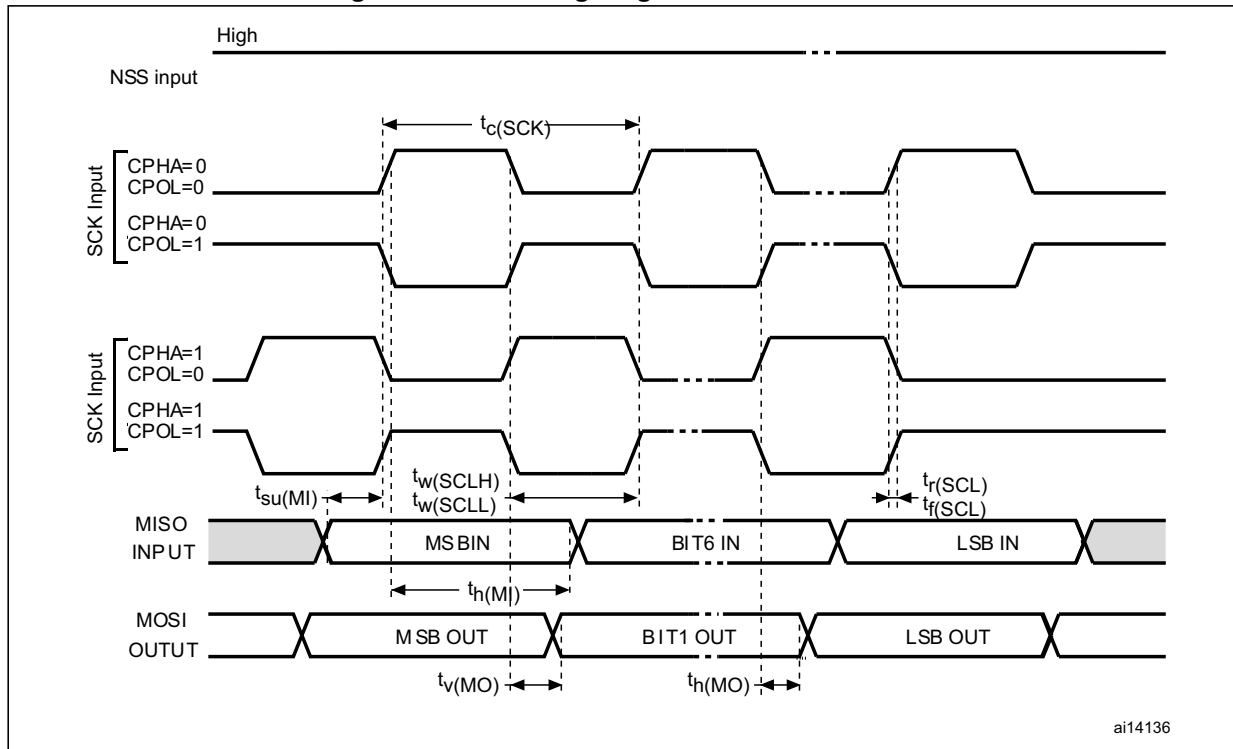

Figure 30. SPI timing diagram - slave mode and CPHA = 1<sup>(1)</sup>



1. Measurement points are done at CMOS levels:  $0.3V_{DD}$  and  $0.7V_{DD}$ .

Figure 31. SPI timing diagram - master mode<sup>(1)</sup>



1. Measurement points are done at CMOS levels:  $0.3V_{DD}$  and  $0.7V_{DD}$ .

**USB characteristics**

The USB interface is USB-IF certified (full speed).

**Table 57. USB startup time**

Symbol	Parameter	Max	Unit
$t_{STARTUP}^{(1)}$	USB transceiver startup time	1	$\mu s$

1. Guaranteed by design, not tested in production.

**Table 58. USB DC electrical characteristics**

Symbol	Parameter	Conditions	Min. <sup>(1)</sup>	Max. <sup>(1)</sup>	Unit
<b>Input levels</b>					
$V_{DD}$	USB operating voltage	-	3.0	3.6	V
$V_{DI}^{(2)}$	Differential input sensitivity	I(USB_DP, USB_DM)	0.2	-	V
$V_{CM}^{(2)}$	Differential common mode range	Includes $V_{DI}$ range	0.8	2.5	
$V_{SE}^{(2)}$	Single ended receiver threshold	-	1.3	2.0	
<b>Output levels</b>					
$V_{OL}^{(3)}$	Static output level low	$R_L$ of 1.5 k $\Omega$ to 3.6 V <sup>(4)</sup>	-	0.3	V
$V_{OH}^{(3)}$	Static output level high	$R_L$ of 15 k $\Omega$ to $V_{SS}^{(4)}$	2.8	3.6	

1. All the voltages are measured from the local ground potential.
2. Guaranteed by characterization results, not tested in production.
3. Guaranteed by test in production.
4.  $R_L$  is the load connected on the USB drivers.

**Figure 32. USB timings: definition of data signal rise and fall time**

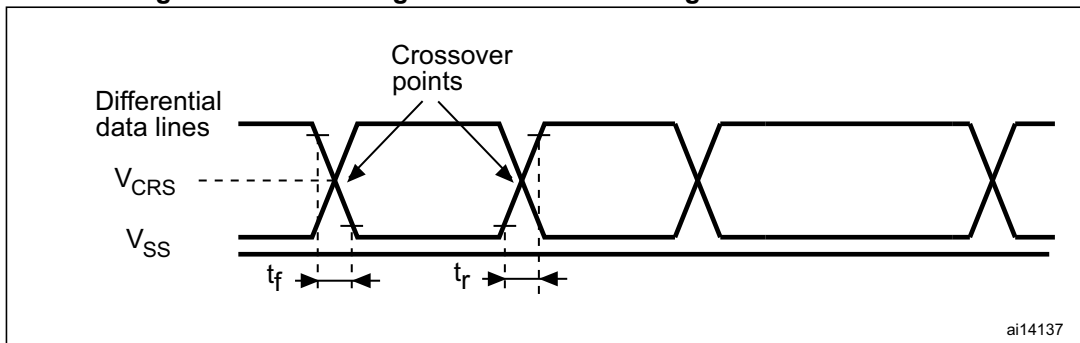

**Table 59. USB: full speed electrical characteristics**

Driver characteristics <sup>(1)</sup>					
Symbol	Parameter	Conditions	Min	Max	Unit
$t_r$	Rise time <sup>(2)</sup>	$C_L = 50 \text{ pF}$	4	20	ns
$t_f$	Fall Time <sup>(2)</sup>	$C_L = 50 \text{ pF}$	4	20	ns

Table 59. USB: full speed electrical characteristics (continued)

Driver characteristics <sup>(1)</sup>					
Symbol	Parameter	Conditions	Min	Max	Unit
$t_{rfm}$	Rise/ fall time matching	$t_r/t_f$	90	110	%
$V_{CRS}$	Output signal crossover voltage		1.3	2.0	V

1. Guaranteed by design, not tested in production.
2. Measured from 10% to 90% of the data signal. For more detailed informations, please refer to USB Specification - Chapter 7 (version 2.0).

## I2S characteristics

Table 60. I2S characteristics

Symbol	Parameter	Conditions	Min	Max	Unit
$f_{MCK}$	I2S Main Clock Output		256 x 8K	256xFs <sup>(1)</sup>	MHz
$f_{CK}$	I2S clock frequency	Master data: 32 bits	-	64xFs	MHz
		Slave data: 32 bits	-	64xFs	
$D_{CK}$	I2S clock frequency duty cycle	Slave receiver, 48KHz	30	70	%
$t_{r(CK)}$	I2S clock rise time	Capacitive load CL=30pF	-	8	ns
$t_{f(CK)}$	I2S clock fall time			8	
$t_{v(WS)}$	WS valid time	Master mode	4	24	ns
$t_{h(WS)}$	WS hold time	Master mode	0	-	
$t_{su(WS)}$	WS setup time	Slave mode	15	-	
$t_{h(WS)}$	WS hold time	Slave mode	0	-	
$t_{su(SD\_MR)}$	Data input setup time	Master receiver	8	-	
$t_{su(SD\_SR)}$	Data input setup time	Slave receiver	9	-	
$t_{h(SD\_MR)}$	Data input hold time	Master receiver	5	-	
		Slave receiver	4	-	
$t_{v(SD\_ST)}$	Data output valid time	Slave transmitter (after enable edge)	-	64	
$t_{h(SD\_ST)}$	Data output hold time	Slave transmitter (after enable edge)	22	-	
$t_{v(SD\_MT)}$	Data output valid time	Master transmitter (after enable edge)	-	12	
$t_{h(SD\_MT)}$	Data output hold time	Master transmitter (after enable edge)	8	-	

1. The maximum for 256xFs is 8 MHz

**Note:** Refer to the I2S section of the product reference manual for more details about the sampling frequency (Fs),  $f_{MCK}$ ,  $f_{CK}$  and  $D_{CK}$  values. These values reflect only the digital peripheral behavior, source clock precision might slightly change them.  $D_{CK}$  depends mainly on the

ODD bit value, digital contribution leads to a min of  $(I2SDIV/(2*I2SDIV+ODD))$  and a max of  $(I2SDIV+ODD)/(2*I2SDIV+ODD)$ . Fs max is supported for each mode/condition.

Figure 33. I<sup>2</sup>S slave timing diagram (Philips protocol)<sup>(1)</sup>

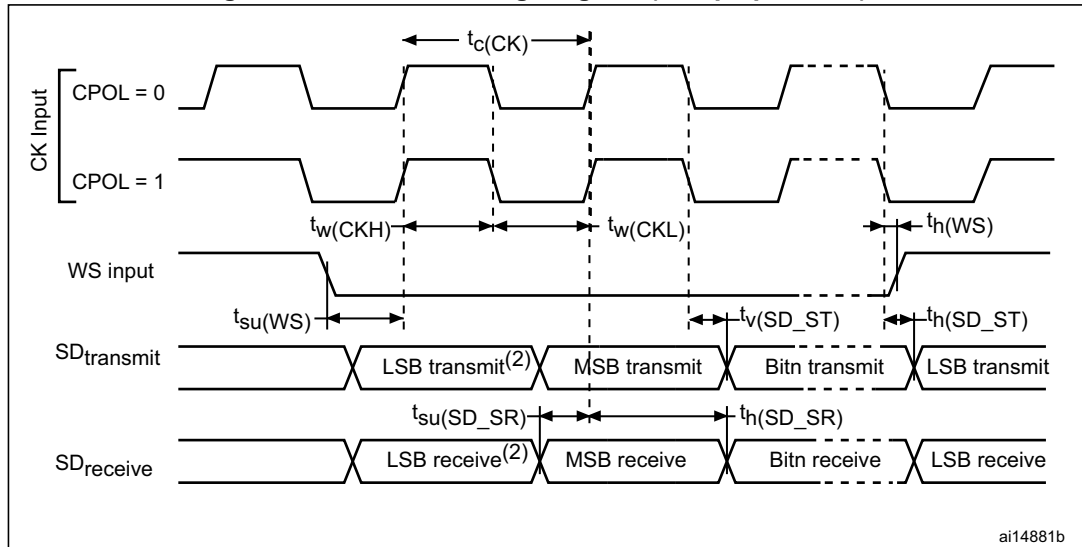

1. Measurement points are done at CMOS levels:  $0.3 \times V_{DD}$  and  $0.7 \times V_{DD}$ .
2. LSB transmit/receive of the previously transmitted byte. No LSB transmit/receive is sent before the first byte.

Figure 34. I<sup>2</sup>S master timing diagram (Philips protocol)<sup>(1)</sup>

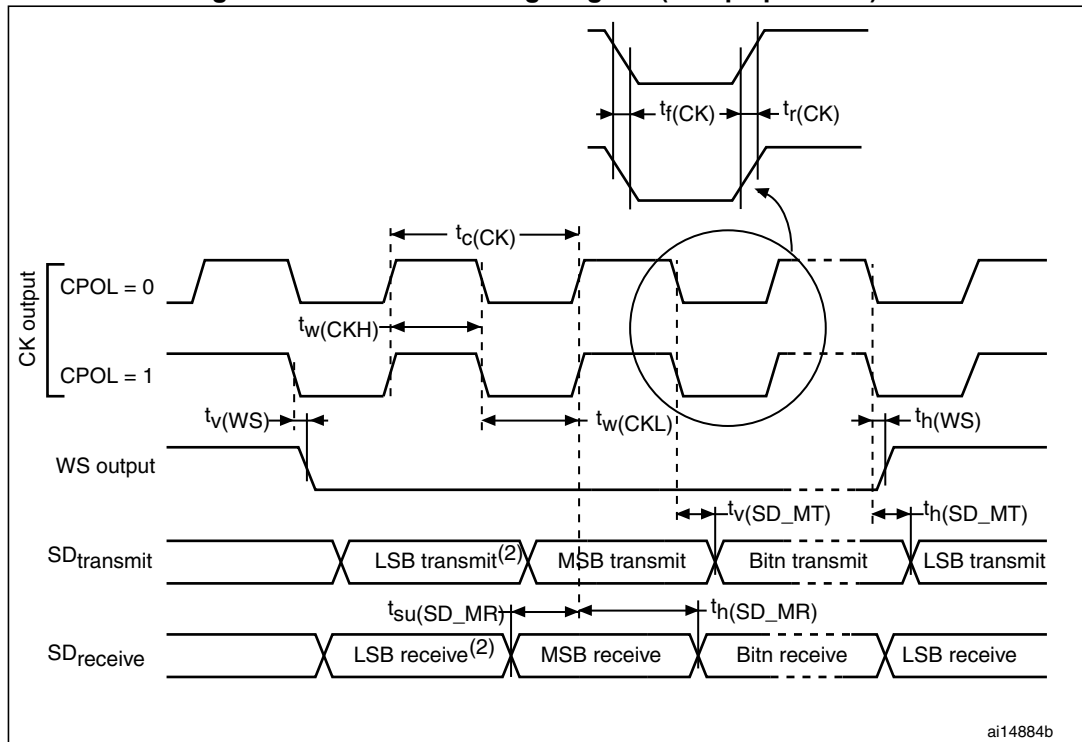

1. Guaranteed by characterization results, not tested in production.
2. LSB transmit/receive of the previously transmitted byte. No LSB transmit/receive is sent before the first byte.

6.3.18 SDIO characteristics

Table 61. SDIO characteristics<sup>(1)</sup>

Symbol	Parameter	Conditions	Min	Max	Unit
$f_{PP}$	Clock frequency in data transfer mode	$CL \leq 30 \text{ pF}$	0	24	MHz
$t_{W(CKL)}$	Clock low time, $f_{PP} = 24 \text{ MHz}$	$CL \leq 30 \text{ pF}$	20 <sup>(2)</sup>	-	ns
$t_{W(CKH)}$	Clock high time, $f_{PP} = 24 \text{ MHz}$	$CL \leq 30 \text{ pF}$	18 <sup>(2)</sup>	-	
$t_r$	Clock rise time, $f_{PP} = 24 \text{ MHz}$	$CL \leq 30 \text{ pF}$	-	5	
$t_f$	Clock fall time, $f_{PP} = 24 \text{ MHz}$	$CL \leq 30 \text{ pF}$	-	5	
CMD, D inputs (referenced to CK) in SD default mode					
			From 2.8 to 3.6 V	-	-
$t_{ISU}$	Input setup time, $f_{PP} = 24 \text{ MHz}$	$CL \leq 30 \text{ pF}$	2	-	ns
$t_{IH}$	Input hold time, $f_{PP} = 24 \text{ MHz}$	$CL \leq 30 \text{ pF}$	1.6	-	
CMD, D outputs (referenced to CK) in SD default mode					
$t_{OVD}$	Output valid default time, $f_{PP} = 24 \text{ MHz}$	$CL \leq 30 \text{ pF}$	0	14	ns
$t_{OHD}$	Output hold default time, $f_{PP} = 24 \text{ MHz}$	$CL \leq 30 \text{ pF}$	0	-	

1. Guaranteed by characterization results, not tested in production.
2. Values measured with a threshold level equal to  $V_{DD}/2$ .

Figure 35. SDIO timings

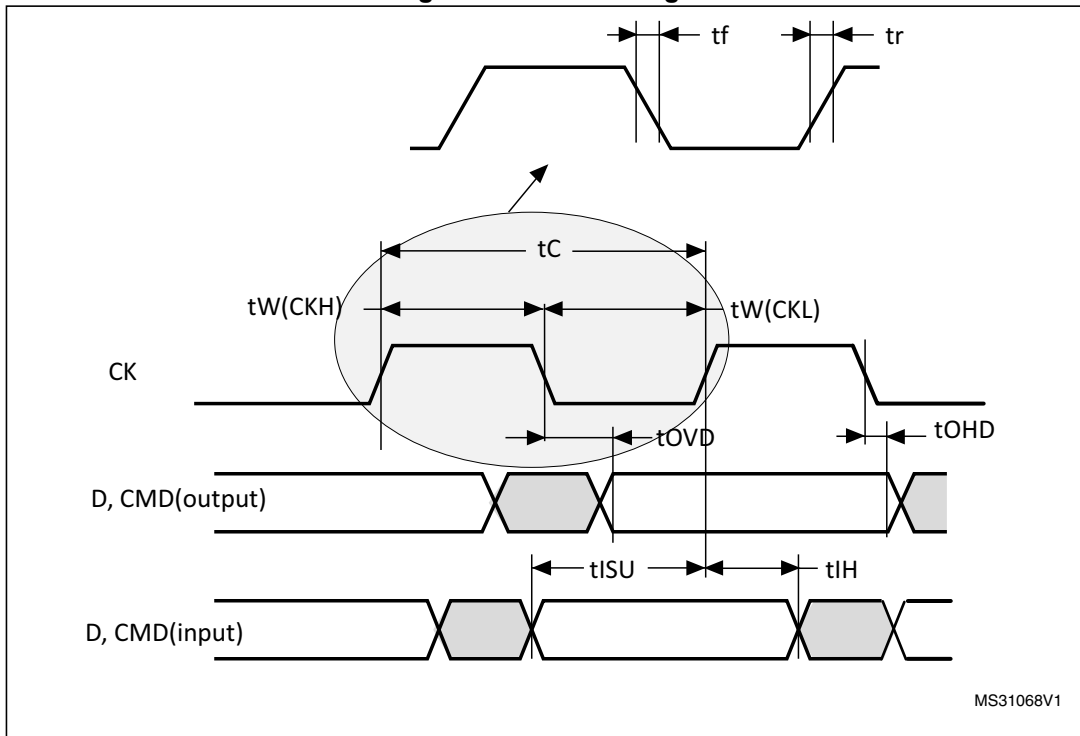

MS31068V1

6.3.19 12-bit ADC characteristics

Unless otherwise specified, the parameters given in [Table 63](#) are guaranteed by design.

Table 62. ADC clock frequency

Symbol	Parameter	Conditions			Min	Max	Unit
f <sub>ADC</sub>	ADC clock frequency	Voltage range 1 & 2	2.4 V ≤ V <sub>DDA</sub> ≤ 3.6 V	V <sub>REF+</sub> = V <sub>DDA</sub>	0.480	16	MHz
				V <sub>REF+</sub> < V <sub>DDA</sub> V <sub>REF+</sub> > 2.4 V		8	
				V <sub>REF+</sub> < V <sub>DDA</sub> V <sub>REF+</sub> ≤ 2.4 V		4	
		1.8 V ≤ V <sub>DDA</sub> ≤ 2.4 V	V <sub>REF+</sub> = V <sub>DDA</sub>	8			
			V <sub>REF+</sub> < V <sub>DDA</sub>	4			
		Voltage range 3					

Table 63. ADC characteristics

Symbol	Parameter	Conditions	Min	Typ	Max	Unit
V <sub>DDA</sub>	Power supply	-	1.8	-	3.6	V
V <sub>REF+</sub>	Positive reference voltage	-	1.8 <sup>(1)</sup>	-	V <sub>DDA</sub>	
V <sub>REF-</sub>	Negative reference voltage	-	-	V <sub>SSA</sub>	-	
I <sub>VDDA</sub>	Current on the V <sub>DDA</sub> input pin	-	-	1000	1450	μA
I <sub>VREF</sub> <sup>(2)</sup>	Current on the V <sub>REF</sub> input pin	Peak	-	400	700	
		Average	-		450	
V <sub>AIN</sub>	Conversion voltage range <sup>(3)</sup>	-	0 <sup>(4)</sup>	-	V <sub>REF+</sub>	V
f <sub>s</sub>	12-bit sampling rate	Direct channels	-	-	1	MSPS
		Multiplexed channels	-	-	0.76	
	10-bit sampling rate	Direct channels	-	-	1.07	MSPS
		Multiplexed channels	-	-	0.8	
	8-bit sampling rate	Direct channels	-	-	1.23	MSPS
		Multiplexed channels	-	-	0.89	
6-bit sampling rate	Direct channels	-	-	1.45	MSPS	
	Multiplexed channels	-	-	1		

Table 63. ADC characteristics (continued)

Symbol	Parameter	Conditions	Min	Typ	Max	Unit
$t_s^{(5)}$	Sampling time	Direct channels $2.4\text{ V} \leq V_{DDA} \leq 3.6\text{ V}$	0.25	-	-	$\mu\text{s}$
		Multiplexed channels $2.4\text{ V} \leq V_{DDA} \leq 3.6\text{ V}$	0.56	-	-	
		Direct channels $1.8\text{ V} \leq V_{DDA} \leq 2.4\text{ V}$	0.56	-	-	
		Multiplexed channels $1.8\text{ V} \leq V_{DDA} \leq 2.4\text{ V}$	1	-	-	
		-	4	-	384	$1/f_{\text{ADC}}$
$t_{\text{CONV}}$	Total conversion time (including sampling time)	$f_{\text{ADC}} = 16\text{ MHz}$	1	-	24.75	$\mu\text{s}$
		-	4 to 384 (sampling phase) + 12 (successive approximation)			$1/f_{\text{ADC}}$
$C_{\text{ADC}}$	Internal sample and hold capacitor	Direct channels	-	16	-	$\text{pF}$
		Multiplexed channels	-		-	
$f_{\text{TRIG}}$	External trigger frequency Regular sequencer	12-bit conversions	-	-	$T_{\text{conv}+1}$	$1/f_{\text{ADC}}$
		6/8/10-bit conversions	-	-	$T_{\text{conv}}$	$1/f_{\text{ADC}}$
$f_{\text{TRIG}}$	External trigger frequency Injected sequencer	12-bit conversions	-	-	$T_{\text{conv}+2}$	$1/f_{\text{ADC}}$
		6/8/10-bit conversions	-	-	$T_{\text{conv}+1}$	$1/f_{\text{ADC}}$
$R_{\text{AIN}}^{(6)}$	Signal source impedance	-	-	-	50	$\text{k}\Omega$
$t_{\text{lat}}$	Injection trigger conversion latency	$f_{\text{ADC}} = 16\text{ MHz}$	219	-	281	$\text{ns}$
		-	3.5	-	4.5	$1/f_{\text{ADC}}$
$t_{\text{latr}}$	Regular trigger conversion latency	$f_{\text{ADC}} = 16\text{ MHz}$	156	-	219	$\text{ns}$
		-	2.5	-	3.5	$1/f_{\text{ADC}}$
$t_{\text{STAB}}$	Power-up time	-	-	-	3.5	$\mu\text{s}$

- The  $V_{\text{ref}+}$  input can be grounded if neither the ADC nor the DAC are used (this allows to shut down an external voltage reference).
- The current consumption through  $V_{\text{REF}}$  is composed of two parameters:
  - one constant (max 300  $\mu\text{A}$ )
  - one variable (max 400  $\mu\text{A}$ ), only during sampling time + 2 first conversion pulses
 So, peak consumption is  $300+400 = 700\text{ }\mu\text{A}$  and average consumption is  $300 + [(4\text{ sampling} + 2) / 16] \times 400 = 450\text{ }\mu\text{A}$  at 1Msps
- $V_{\text{REF}+}$  can be internally connected to  $V_{\text{DDA}}$  and  $V_{\text{REF}-}$  can be internally connected to  $V_{\text{SSA}}$ , depending on the package. Refer to [Section 4: Pin descriptions](#) for further details.
- $V_{\text{SSA}}$  or  $V_{\text{REF}-}$  must be tied to ground.
- Minimum sampling time is reached for an external input impedance limited to a value as defined in [Table 65: Maximum source impedance  \$R\_{\text{AIN max}}\$](#)
- External impedance has another high value limitation when using short sampling time as defined in [Table 65: Maximum source impedance  \$R\_{\text{AIN max}}\$](#)

Table 64. ADC accuracy<sup>(1)(2)</sup>

Symbol	Parameter	Test conditions	Min <sup>(3)</sup>	Typ	Max <sup>(3)</sup>	Unit
ET	Total unadjusted error	$2.4\text{ V} \leq V_{DDA} \leq 3.6\text{ V}$ $2.4\text{ V} \leq V_{REF+} \leq 3.6\text{ V}$ $f_{ADC} = 8\text{ MHz}, R_{AIN} = 50\ \Omega$ $T_A = -40\text{ to }105\text{ }^\circ\text{C}$	-	2	4	LSB
EO	Offset error		-	1	2	
EG	Gain error		-	1.5	3.5	
ED	Differential linearity error		-	1	2	
EL	Integral linearity error		-	1.7	3	
ENOB	Effective number of bits	$2.4\text{ V} \leq V_{DDA} \leq 3.6\text{ V}$ $V_{DDA} = V_{REF+}$ $f_{ADC} = 16\text{ MHz}, R_{AIN} = 50\ \Omega$ $T_A = -40\text{ to }105\text{ }^\circ\text{C}$ $F_{input} = 10\text{ kHz}$	9.2	10	-	bits
SINAD	Signal-to-noise and distortion ratio		57.5	62	-	dB
SNR	Signal-to-noise ratio		57.5	62	-	
THD	Total harmonic distortion		-	-70	-65	
ENOB	Effective number of bits		9.2	10	-	
SINAD	Signal-to-noise and distortion ratio	$1.8\text{ V} \leq V_{DDA} \leq 2.4\text{ V}$ $V_{DDA} = V_{REF+}$ $f_{ADC} = 8\text{ MHz or }4\text{ MHz}, R_{AIN} = 50\ \Omega$ $T_A = -40\text{ to }105\text{ }^\circ\text{C}$ $F_{input} = 10\text{ kHz}$	57.5	62	-	dB
SNR	Signal-to-noise ratio		57.5	62	-	
THD	Total harmonic distortion		-	-70	-65	
ENOB	Effective number of bits		9.2	10	-	
ET	Total unadjusted error	$2.4\text{ V} \leq V_{DDA} \leq 3.6\text{ V}$ $1.8\text{ V} \leq V_{REF+} \leq 2.4\text{ V}$ $f_{ADC} = 4\text{ MHz}, R_{AIN} = 50\ \Omega$ $T_A = -40\text{ to }105\text{ }^\circ\text{C}$	-	4	6.5	LSB
EO	Offset error		-	2	4	
EG	Gain error		-	4	6	
ED	Differential linearity error		-	1	2	
EL	Integral linearity error		-	1.5	3	
ET	Total unadjusted error	$1.8\text{ V} \leq V_{DDA} \leq 2.4\text{ V}$ $1.8\text{ V} \leq V_{REF+} \leq 2.4\text{ V}$ $f_{ADC} = 4\text{ MHz}, R_{AIN} = 50\ \Omega$ $T_A = -40\text{ to }105\text{ }^\circ\text{C}$	-	2	3	LSB
EO	Offset error		-	1	1.5	
EG	Gain error		-	1.5	2	
ED	Differential linearity error		-	1	2	
EL	Integral linearity error		-	1	1.5	

1. ADC DC accuracy values are measured after internal calibration.
2. ADC accuracy vs. negative injection current: Injecting a negative current on any analog input pins should be avoided as this significantly reduces the accuracy of the conversion being performed on another analog input. It is recommended to add a Schottky diode (pin to ground) to analog pins which may potentially inject negative currents. Any positive injection current within the limits specified for  $I_{INJ(PIN)}$  and  $\Sigma I_{INJ(PIN)}$  in [Section 6.3.13](#) does not affect the ADC accuracy.
3. Guaranteed by characterization results, not tested in production.

Figure 36. ADC accuracy characteristics

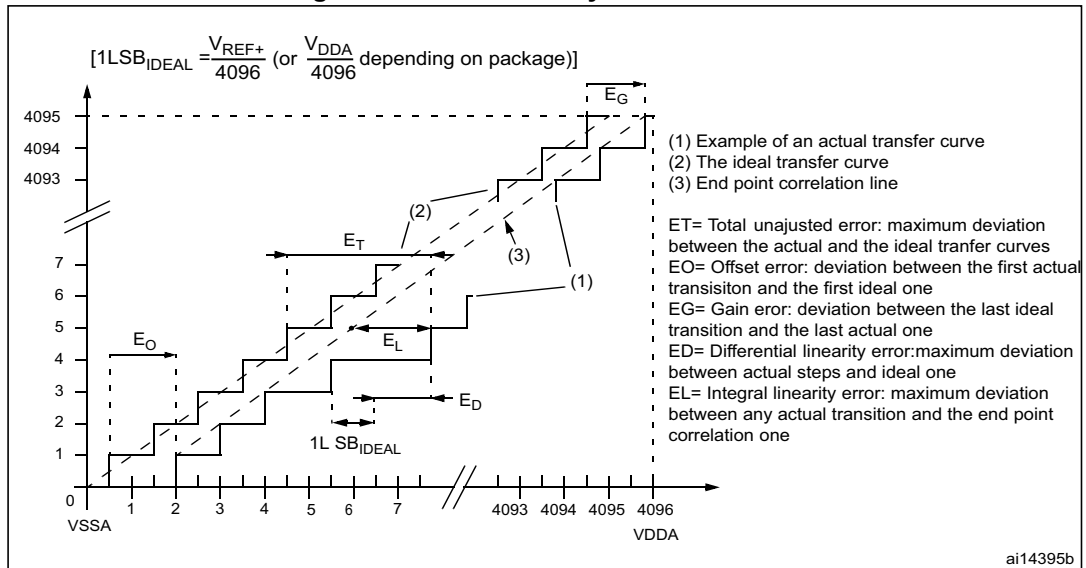
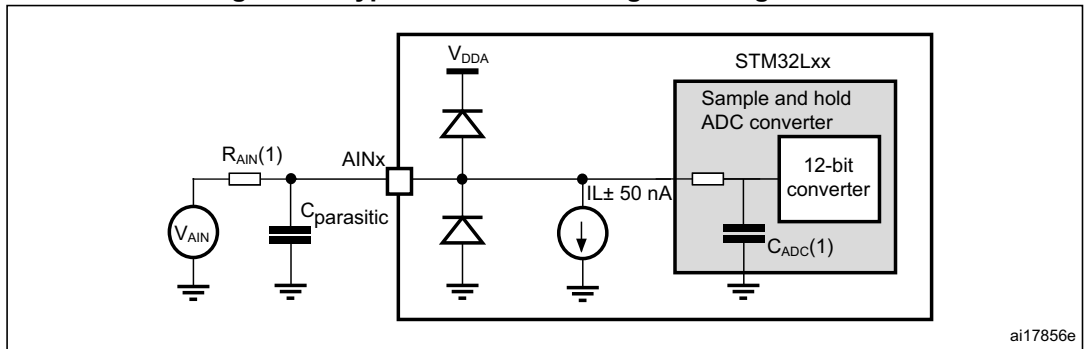

Figure 37. Typical connection diagram using the ADC



1. Refer to [Table 65: Maximum source impedance RAIN max](#) for the value of RAIN and [Table 63: ADC characteristics](#) for the value of CADC.
2. Cparasitic represents the capacitance of the PCB (dependent on soldering and PCB layout quality) plus the pad capacitance (roughly 7 pF). A high Cparasitic value will downgrade conversion accuracy. To remedy this, fADC should be reduced.

Figure 38. Maximum dynamic current consumption on V<sub>REF+</sub> supply pin during ADC conversion

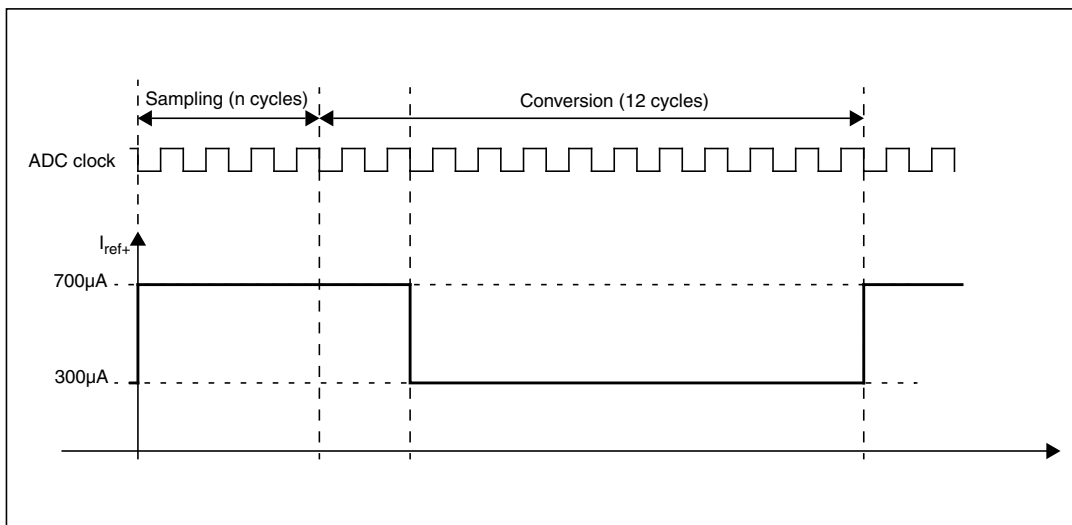

Table 65. Maximum source impedance R<sub>AIN</sub> max<sup>(1)</sup>

Ts (µs)	R <sub>AIN</sub> max (kΩ)				Ts (cycles) f <sub>ADC</sub> = 16 MHz <sup>(2)</sup>
	Multiplexed channels		Direct channels		
	2.4 V < V <sub>DDA</sub> < 3.6 V	1.8 V < V <sub>DDA</sub> < 2.4 V	2.4 V < V <sub>DDA</sub> < 3.6 V	1.8 V < V <sub>DDA</sub> < 2.4 V	
0.25	Not allowed	Not allowed	0.7	Not allowed	4
0.5625	0.8	Not allowed	2.0	1.0	9
1	2.0	0.8	4.0	3.0	16
1.5	3.0	1.8	6.0	4.5	24
3	6.8	4.0	15.0	10.0	48
6	15.0	10.0	30.0	20.0	96
12	32.0	25.0	50.0	40.0	192
24	50.0	50.0	50.0	50.0	384

1. Guaranteed by design, not tested in production.
2. Number of samples calculated for f<sub>ADC</sub> = 16 MHz. For f<sub>ADC</sub> = 8 and 4 MHz the number of sampling cycles can be reduced with respect to the minimum sampling time Ts (µs),

**General PCB design guidelines**

Power supply decoupling should be performed as shown in *Figure 11*. The applicable procedure depends on whether V<sub>REF+</sub> is connected to V<sub>DDA</sub> or not. The 100 nF capacitors should be ceramic (good quality). They should be placed as close as possible to the chip.

### 6.3.20 DAC electrical specifications

Data guaranteed by design, not tested in production, unless otherwise specified.

**Table 66. DAC characteristics**

Symbol	Parameter	Conditions	Min	Typ	Max	Unit
$V_{DDA}$	Analog supply voltage		1.8	-	3.6	V
$V_{REF+}$	Reference supply voltage	$V_{REF+}$ must always be below $V_{DDA}$	1.8	-	3.6	
$V_{REF-}$	Lower reference voltage		$V_{SSA}$			
$I_{DDVREF+}^{(1)}$	Current consumption on $V_{REF+}$ supply $V_{REF+} = 3.3\text{ V}$	No load, middle code (0x800)	-	130	220	$\mu\text{A}$
		No load, worst code (0x000)	-	220	350	
$I_{DDA}^{(1)}$	Current consumption on $V_{DDA}$ supply $V_{DDA} = 3.3\text{ V}$	No load, middle code (0x800)	-	210	320	
		No load, worst code (0xF1C)	-	320	520	
$R_L^{(2)}$	Resistive load	DAC output buffer ON	5	-	-	$\text{k}\Omega$
$C_L^{(2)}$	Capacitive load		-	-	50	$\text{pF}$
$R_O$	Output impedance	DAC output buffer OFF	12	16	20	$\text{k}\Omega$
$V_{DAC\_OUT}$	Voltage on DAC_OUT output	DAC output buffer ON	0.2	-	$V_{DDA} - 0.2$	V
		DAC output buffer OFF	0.5	-	$V_{REF+} - 1\text{LSB}$	mV
$\text{DNL}^{(1)}$	Differential non linearity <sup>(3)</sup>	$C_L \leq 50\text{ pF}$ , $R_L \geq 5\text{ k}\Omega$ DAC output buffer ON	-	1.5	3	LSB
		No $R_L$ , $C_L \leq 50\text{ pF}$ DAC output buffer OFF	-	1.5	3	
$\text{INL}^{(1)}$	Integral non linearity <sup>(4)</sup>	$C_L \leq 50\text{ pF}$ , $R_L \geq 5\text{ k}\Omega$ DAC output buffer ON	-	2	4	
		No $R_L$ , $C_L \leq 50\text{ pF}$ DAC output buffer OFF	-	2	4	
Offset <sup>(1)</sup>	Offset error at code 0x800 <sup>(5)</sup>	$C_L \leq 50\text{ pF}$ , $R_L \geq 5\text{ k}\Omega$ DAC output buffer ON	-	$\pm 10$	$\pm 25$	
		No $R_L$ , $C_L \leq 50\text{ pF}$ DAC output buffer OFF	-	$\pm 5$	$\pm 8$	
Offset <sup>(1)</sup>	Offset error at code 0x001 <sup>(6)</sup>	No $R_L$ , $C_L \leq 50\text{ pF}$ DAC output buffer OFF	-	$\pm 1.5$	$\pm 5$	

Table 66. DAC characteristics (continued)

Symbol	Parameter	Conditions	Min	Typ	Max	Unit
dOffset/dT <sup>(1)</sup>	Offset error temperature coefficient (code 0x800)	V <sub>DDA</sub> = 3.3V V <sub>REF+</sub> = 3.0V T <sub>A</sub> = 0 to 50 °C DAC output buffer OFF	-20	-10	0	μV/°C
		V <sub>DDA</sub> = 3.3V V <sub>REF+</sub> = 3.0V T <sub>A</sub> = 0 to 50 °C DAC output buffer ON	0	20	50	
Gain <sup>(1)</sup>	Gain error <sup>(7)</sup>	C <sub>L</sub> ≤ 50 pF, R <sub>L</sub> ≥ 5 kΩ DAC output buffer ON	-	+0.1 / -0.2%	+0.2 / -0.5%	%
		No R <sub>L</sub> , C <sub>L</sub> ≤ 50 pF DAC output buffer OFF	-	+0 / -0.2%	+0 / -0.4%	
dGain/dT <sup>(1)</sup>	Gain error temperature coefficient	V <sub>DDA</sub> = 3.3V V <sub>REF+</sub> = 3.0V T <sub>A</sub> = 0 to 50 °C DAC output buffer OFF	-10	-2	0	μV/°C
		V <sub>DDA</sub> = 3.3V V <sub>REF+</sub> = 3.0V T <sub>A</sub> = 0 to 50 °C DAC output buffer ON	-40	-8	0	
TUE <sup>(1)</sup>	Total unadjusted error	C <sub>L</sub> ≤ 50 pF, R <sub>L</sub> ≥ 5 kΩ DAC output buffer ON	-	12	30	LSB
		No R <sub>L</sub> , C <sub>L</sub> ≤ 50 pF DAC output buffer OFF	-	8	12	
t <sub>SETTLING</sub>	Settling time (full scale: for a 12-bit code transition between the lowest and the highest input codes till DAC_OUT reaches final value ±1LSB)	C <sub>L</sub> ≤ 50 pF, R <sub>L</sub> ≥ 5 kΩ	-	7	12	μs
Update rate	Max frequency for a correct DAC_OUT change (95% of final value) with 1 LSB variation in the input code	C <sub>L</sub> ≤ 50 pF, R <sub>L</sub> ≥ 5 kΩ	-	-	1	MspS
t <sub>WAKEUP</sub>	Wakeup time from off state (setting the ENx bit in the DAC Control register) <sup>(8)</sup>	C <sub>L</sub> ≤ 50 pF, R <sub>L</sub> ≥ 5 kΩ	-	9	15	μs
PSRR+	V <sub>DDA</sub> supply rejection ratio (static DC measurement)	C <sub>L</sub> ≤ 50 pF, R <sub>L</sub> ≥ 5 kΩ	-	-60	-35	dB

1. Data based on characterization results.

2. Connected between DAC\_OUT and V<sub>SSA</sub>.

3. Difference between two consecutive codes - 1 LSB.

4. Difference between measured value at Code  $i$  and the value at Code  $i$  on a line drawn between Code 0 and last Code 4095.
5. Difference between the value measured at Code (0x800) and the ideal value =  $V_{REF+}/2$ .
6. Difference between the value measured at Code (0x001) and the ideal value.
7. Difference between ideal slope of the transfer function and measured slope computed from code 0x000 and 0xFFFF when buffer is OFF, and from code giving 0.2 V and  $(V_{DDA} - 0.2)$  V when buffer is ON.
8. In buffered mode, the output can overshoot above the final value for low input code (starting from min value).

Figure 39. 12-bit buffered /non-buffered DAC

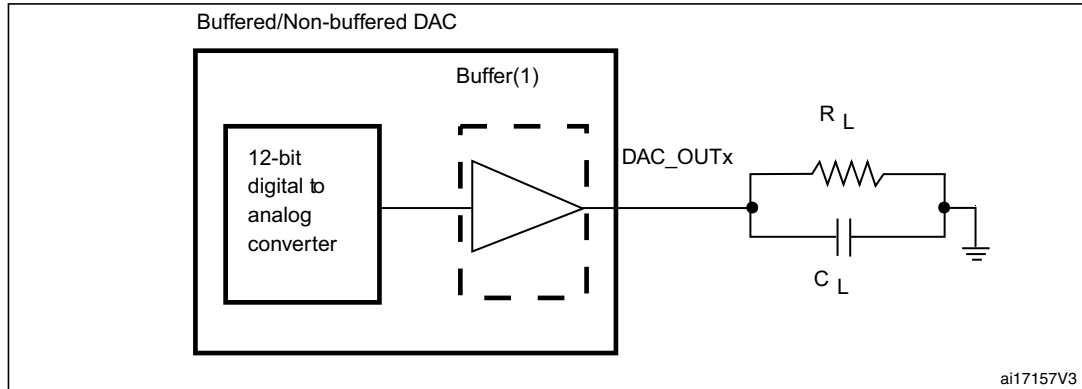

1. The DAC integrates an output buffer that can be used to reduce the output impedance and to drive external loads directly without the use of an external operational amplifier. The buffer can be bypassed by configuring the BOFFx bit in the DAC\_CR register.

### 6.3.21 Operational amplifier characteristics

Table 67. Operational amplifier characteristics

Symbol	Parameter	Condition <sup>(1)</sup>	Min <sup>(2)</sup>	Typ	Max <sup>(2)</sup>	Unit	
CMIR	Common mode input range	-	0	-	$V_{DD}$		
$V_{I\text{OFFSET}}$	Input offset voltage	Maximum calibration range	-	-	$\pm 15$	mV	
		After offset calibration	-	-	$\pm 1.5$		
$\Delta V_{I\text{OFFSET}}$	Input offset voltage drift	Normal mode	-	-	$\pm 40$	$\mu\text{V}/^\circ\text{C}$	
		Low-power mode	-	-	$\pm 80$		
$I_{IB}$	Input current bias	Dedicated input	75 °C	-	-	1	nA
		General purpose input		-	-	10	
$I_{LOAD}$	Drive current	Normal mode	-	-	500	$\mu\text{A}$	
		Low-power mode	-	-	100		
$I_{DD}$	Consumption	Normal mode	No load, quiescent mode	-	100	220	$\mu\text{A}$
		Low-power mode		-	30	60	
CMRR	Common mode rejection ration	Normal mode	-	-	-85	-	dB
		Low-power mode	-	-	-90	-	

Table 67. Operational amplifier characteristics (continued)

Symbol	Parameter		Condition <sup>(1)</sup>	Min <sup>(2)</sup>	Typ	Max <sup>(2)</sup>	Unit		
PSRR	Power supply rejection ratio	Normal mode	DC	-	-85	-	dB		
		Low-power mode		-	-90	-			
GBW	Bandwidth	Normal mode	$V_{DD} > 2.4\text{ V}$	400	1000	3000	kHz		
		Low-power mode		150	300	800			
		Normal mode	$V_{DD} < 2.4\text{ V}$	200	500	2200			
		Low-power mode		70	150	800			
SR	Slew rate	Normal mode	$V_{DD} > 2.4\text{ V}$ (between 0.1 V and $V_{DD}-0.1\text{ V}$ )	-	700	-	V/ms		
		Low-power mode		$V_{DD} > 2.4\text{ V}$	-	100		-	
		Normal mode	$V_{DD} < 2.4\text{ V}$	-	300	-			
		Low-power mode		-	50	-			
AO	Open loop gain	Normal mode		55	100	-	dB		
		Low-power mode		65	110	-			
$R_L$	Resistive load	Normal mode	$V_{DD} < 2.4\text{ V}$	4	-	-	k $\Omega$		
		Low-power mode		20	-	-			
$C_L$	Capacitive load		-	-	-	50	pF		
$V_{OH\text{SAT}}$	High saturation voltage	Normal mode	$I_{\text{LOAD}} = \text{max or } R_L = \text{min}$	$V_{DD}-100$	-	-	mV		
		Low-power mode		$V_{DD}-50$	-	-			
$V_{OL\text{SAT}}$	Low saturation voltage	Normal mode		-	-	100			
		Low-power mode		-	-	50			
$\phi_m$	Phase margin			-	-	60		-	°
GM	Gain margin			-	-	-12		-	dB
$t_{\text{OFFTRIM}}$	Offset trim time: during calibration, minimum time needed between two steps to have 1 mV accuracy		-	-	1	-	ms		
$t_{\text{WAKEUP}}$	Wakeup time	Normal mode	$C_L \leq 50\text{ pf, } R_L \geq 4\text{ k}\Omega$	-	10	-	$\mu\text{s}$		
		Low-power mode	$C_L \leq 50\text{ pf, } R_L \geq 20\text{ k}\Omega$	-	30	-			

1. Operating conditions are limited to junction temperature (0 °C to 105 °C) when  $V_{DD}$  is below 2 V. Otherwise to the full ambient temperature range (-40 °C to 85 °C, -40 °C to 105 °C).

2. Guaranteed by characterization results, not tested in production.

### 6.3.22 Temperature sensor characteristics

**Table 68. Temperature sensor calibration values**

Calibration value name	Description	Memory address
TS_CAL1	TS ADC raw data acquired at temperature of 30 °C ±5 °C V <sub>DDA</sub> = 3 V ±10 mV	0x1FF8 00FA - 0x1FF8 00FB
TS_CAL2	TS ADC raw data acquired at temperature of 110 °C ±5 °C V <sub>DDA</sub> = 3 V ±10 mV	0x1FF8 00FE - 0x1FF8 00FF

**Table 69. Temperature sensor characteristics**

Symbol	Parameter	Min	Typ	Max	Unit
T <sub>L</sub> <sup>(1)</sup>	V <sub>SENSE</sub> linearity with temperature	-	±1	±2	°C
Avg_Slope <sup>(1)</sup>	Average slope	1.48	1.61	1.75	mV/°C
V <sub>110</sub>	Voltage at 110°C ±5°C <sup>(2)</sup>	612	626.8	641.5	mV
I <sub>DDA(TEMP)</sub> <sup>(3)</sup>	Current consumption	-	3.4	6	µA
t <sub>START</sub> <sup>(3)</sup>	Startup time	-	-	10	µs
T <sub>S_temp</sub> <sup>(3)</sup>	ADC sampling time when reading the temperature	4	-	-	

1. Guaranteed by characterization results, not tested in production.
2. Measured at V<sub>DD</sub> = 3 V ±10 mV. V<sub>110</sub> ADC conversion result is stored in the TS\_CAL2 byte.
3. Guaranteed by design, not tested in production.

### 6.3.23 Comparator

**Table 70. Comparator 1 characteristics**

Symbol	Parameter	Conditions	Min <sup>(1)</sup>	Typ	Max <sup>(1)</sup>	Unit
V <sub>DDA</sub>	Analog supply voltage	-	1.65		3.6	V
R <sub>400K</sub>	R <sub>400K</sub> value	-	-	400	-	kΩ
R <sub>10K</sub>	R <sub>10K</sub> value	-	-	10	-	
V <sub>IN</sub>	Comparator 1 input voltage range	-	0.6	-	V <sub>DDA</sub>	V
t <sub>START</sub>	Comparator startup time	-	-	7	10	µs
t <sub>d</sub>	Propagation delay <sup>(2)</sup>	-	-	3	10	
V <sub>offset</sub>	Comparator offset	-	-	±3	±10	mV
d <sub>Voffset/dt</sub>	Comparator offset variation in worst voltage stress conditions	V <sub>DDA</sub> = 3.6 V V <sub>IN+</sub> = 0 V V <sub>IN-</sub> = V <sub>REFINT</sub> T <sub>A</sub> = 25 °C	0	1.5	10	mV/1000 h
I <sub>COMP1</sub>	Current consumption <sup>(3)</sup>	-	-	160	260	nA

1. Guaranteed by characterization results, not tested in production.
2. The delay is characterized for 100 mV input step with 10 mV overdrive on the inverting input, the non-inverting input set to the reference.
3. Comparator consumption only. Internal reference voltage not included.

Table 71. Comparator 2 characteristics

Symbol	Parameter	Conditions	Min	Typ	Max <sup>(1)</sup>	Unit
V <sub>DDA</sub>	Analog supply voltage	-	1.65	-	3.6	V
V <sub>IN</sub>	Comparator 2 input voltage range	-	0	-	V <sub>DDA</sub>	V
t <sub>START</sub>	Comparator startup time	Fast mode	-	15	20	μs
		Slow mode	-	20	25	
t <sub>d slow</sub>	Propagation delay <sup>(2)</sup> in slow mode	1.65 V ≤ V <sub>DDA</sub> ≤ 2.7 V	-	1.8	3.5	
		2.7 V ≤ V <sub>DDA</sub> ≤ 3.6 V	-	2.5	6	
t <sub>d fast</sub>	Propagation delay <sup>(2)</sup> in fast mode	1.65 V ≤ V <sub>DDA</sub> ≤ 2.7 V	-	0.8	2	
		2.7 V ≤ V <sub>DDA</sub> ≤ 3.6 V	-	1.2	4	
V <sub>offset</sub>	Comparator offset error		-	±4	±20	mV
dThreshold/ dt	Threshold voltage temperature coefficient	V <sub>DDA</sub> = 3.3V T <sub>A</sub> = 0 to 50 °C V <sub>-</sub> = V <sub>REFINT</sub> , 3/4 V <sub>REFINT</sub> , 1/2 V <sub>REFINT</sub> , 1/4 V <sub>REFINT</sub>	-	15	30	ppm /°C
I <sub>COMP2</sub>	Current consumption <sup>(3)</sup>	Fast mode	-	3.5	5	μA
		Slow mode	-	0.5	2	

1. Guaranteed by characterization results, not tested in production.
2. The delay is characterized for 100 mV input step with 10 mV overdrive on the inverting input, the non-inverting input set to the reference.
3. Comparator consumption only. Internal reference voltage (necessary for comparator operation) is not included.

### 6.3.24 LCD controller

The device embeds a built-in step-up converter to provide a constant LCD reference voltage independently from the  $V_{DD}$  voltage. An external capacitor  $C_{ext}$  must be connected to the  $V_{LCD}$  pin to decouple this converter.

**Table 72. LCD controller characteristics**

Symbol	Parameter	Min	Typ	Max	Unit
$V_{LCD}$	LCD external voltage	-	-	3.6	V
$V_{LCD0}$	LCD internal reference voltage 0	-	2.6	-	
$V_{LCD1}$	LCD internal reference voltage 1	-	2.73	-	
$V_{LCD2}$	LCD internal reference voltage 2	-	2.86	-	
$V_{LCD3}$	LCD internal reference voltage 3	-	2.98	-	
$V_{LCD4}$	LCD internal reference voltage 4	-	3.12	-	
$V_{LCD5}$	LCD internal reference voltage 5	-	3.26	-	
$V_{LCD6}$	LCD internal reference voltage 6	-	3.4	-	
$V_{LCD7}$	LCD internal reference voltage 7	-	3.55	-	
$C_{ext}$	$V_{LCD}$ external capacitance	0.1	-	2	$\mu\text{F}$
$I_{LCD}^{(1)}$	Supply current at $V_{DD} = 2.2 \text{ V}$	-	3.3	-	$\mu\text{A}$
	Supply current at $V_{DD} = 3.0 \text{ V}$	-	3.1	-	
$R_{Htot}^{(2)}$	Low drive resistive network overall value	5.28	6.6	7.92	$\text{M}\Omega$
$R_L^{(2)}$	High drive resistive network total value	192	240	288	$\text{k}\Omega$
$V_{44}$	Segment/Common highest level voltage	-	-	$V_{LCD}$	V
$V_{34}$	Segment/Common 3/4 level voltage	-	$3/4 V_{LCD}$	-	V
$V_{23}$	Segment/Common 2/3 level voltage	-	$2/3 V_{LCD}$	-	
$V_{12}$	Segment/Common 1/2 level voltage	-	$1/2 V_{LCD}$	-	
$V_{13}$	Segment/Common 1/3 level voltage	-	$1/3 V_{LCD}$	-	
$V_{14}$	Segment/Common 1/4 level voltage	-	$1/4 V_{LCD}$	-	
$V_0$	Segment/Common lowest level voltage	0	-	-	
$\Delta V_{xx}^{(3)}$	Segment/Common level voltage error $T_A = -40 \text{ to } 105 \text{ }^\circ\text{C}$	-	-	$\pm 50$	mV

1. LCD enabled with 3 V internal step-up active, 1/8 duty, 1/4 bias, division ratio= 64, all pixels active, no LCD connected.
2. Guaranteed by design, not tested in production.
3. Guaranteed by characterization results, not tested in production.

## 7 Package characteristics

### 7.1 Package mechanical data

In order to meet environmental requirements, ST offers these devices in different grades of ECOPACK<sup>®</sup> packages, depending on their level of environmental compliance. ECOPACK<sup>®</sup> specifications, grade definitions and product status are available at: [www.st.com](http://www.st.com). ECOPACK<sup>®</sup> is an ST trademark.

#### 7.1.1 LQFP144, 20 x 20 mm, 144-pin low-profile quad flat package

Figure 40. LQFP144, 20 x 20 mm, 144-pin low-profile quad flat package outline

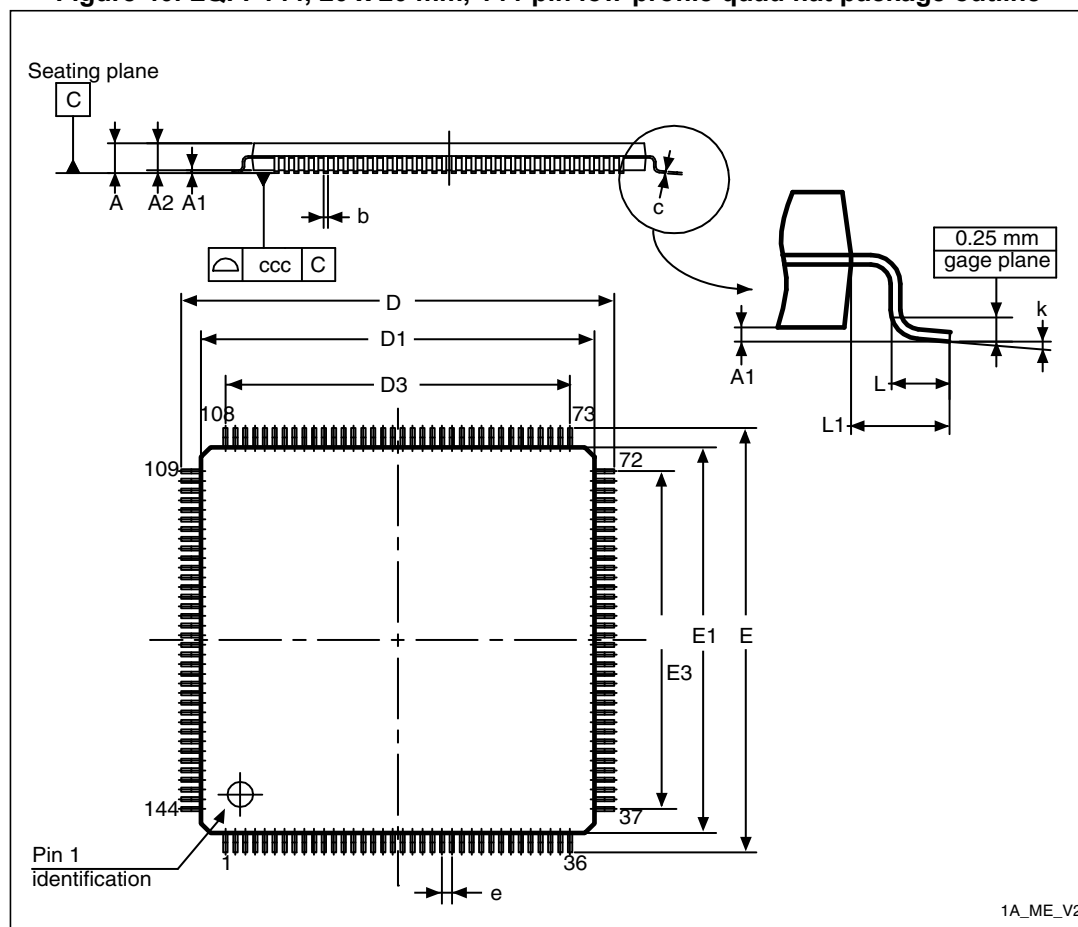

1. Drawing is not to scale.

**Table 73. LQFP144, 20 x 20 mm, 144-pin low-profile quad flat package mechanical data**

Symbol	millimeters			inches <sup>(1)</sup>		
	Min	Typ	Max	Min	Typ	Max
A	-	-	1.600	-	-	0.0630
A1	0.050	-	0.150	0.0020	-	0.0059
A2	1.350	1.400	1.450	0.0531	0.0551	0.0571
b	0.170	0.220	0.270	0.0067	0.0087	0.0106
c	0.090	-	0.200	0.0035	-	0.0079
D	21.800	22.000	22.200	0.8583	0.8661	0.8740
D1	19.800	20.000	20.200	0.7795	0.7874	0.7953
D3	-	17.500	-	-	0.6890	-
E	21.800	22.000	22.200	0.8583	0.8661	0.8740
E1	19.800	20.000	20.200	0.7795	0.7874	0.7953
E3	-	17.500	-	-	0.6890	-
e	-	0.500	-	-	0.0197	-
L	0.450	0.600	0.750	0.0177	0.0236	0.0295
L1	-	1.000	-	-	0.0394	-
k	0°	3.5°	7°	0°	3.5°	7°
ccc	-	-	0.080	-	-	0.0031

1. Values in inches are converted from mm and rounded to 4 decimal digits.

**Figure 41. LQFP144 recommended footprint**

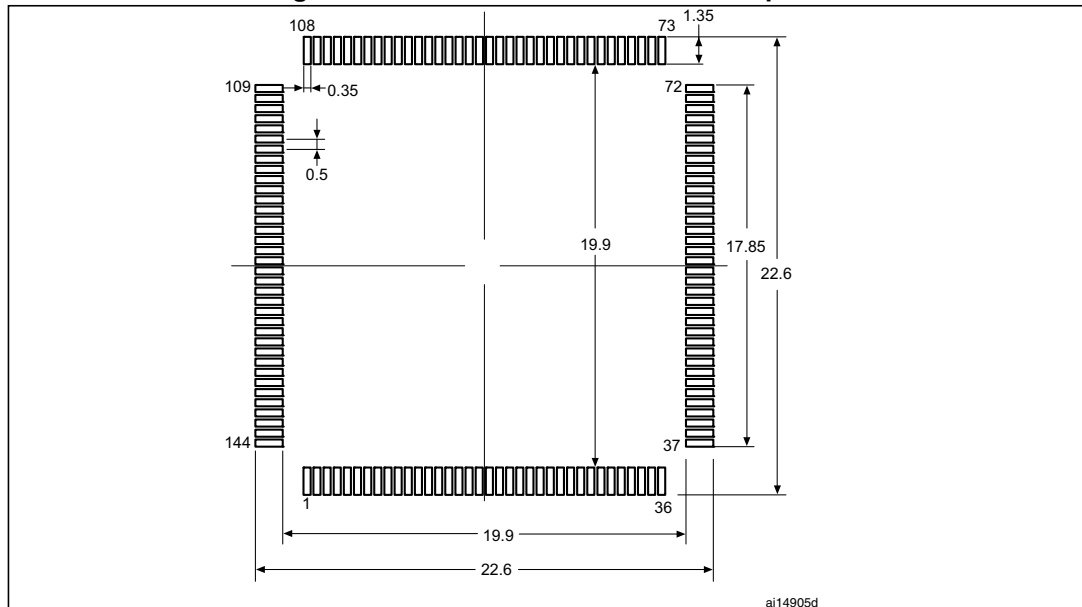

1. Dimensions are in millimeters.

### Marking of engineering samples

The following figure shows the engineering sample marking for the LQFP144 package. Only the information field containing the engineering sample marking is shown.

Figure 42. LQFP144 package top view

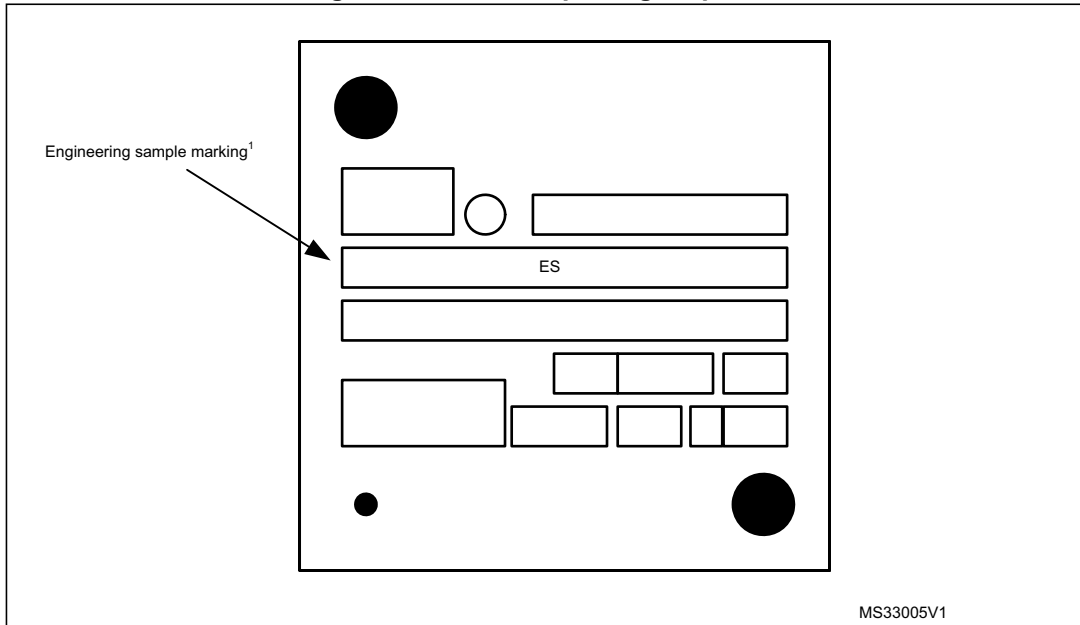

1. Samples marked "ES" are to be considered as "Engineering Samples": i.e. they are intended to be sent to customer for electrical compatibility evaluation and may be used to start customer qualification where specifically authorized by ST in writing. In no event ST will be liable for any customer usage in production. Only if ST has authorized in writing the customer qualification Engineering Samples can be used for reliability qualification trials.

7.1.2 LQFP100, 14 x 14 mm, 100-pin low-profile quad flat package

Figure 43. LQFP100, 14 x 14 mm, 100-pin low-profile quad flat package outline

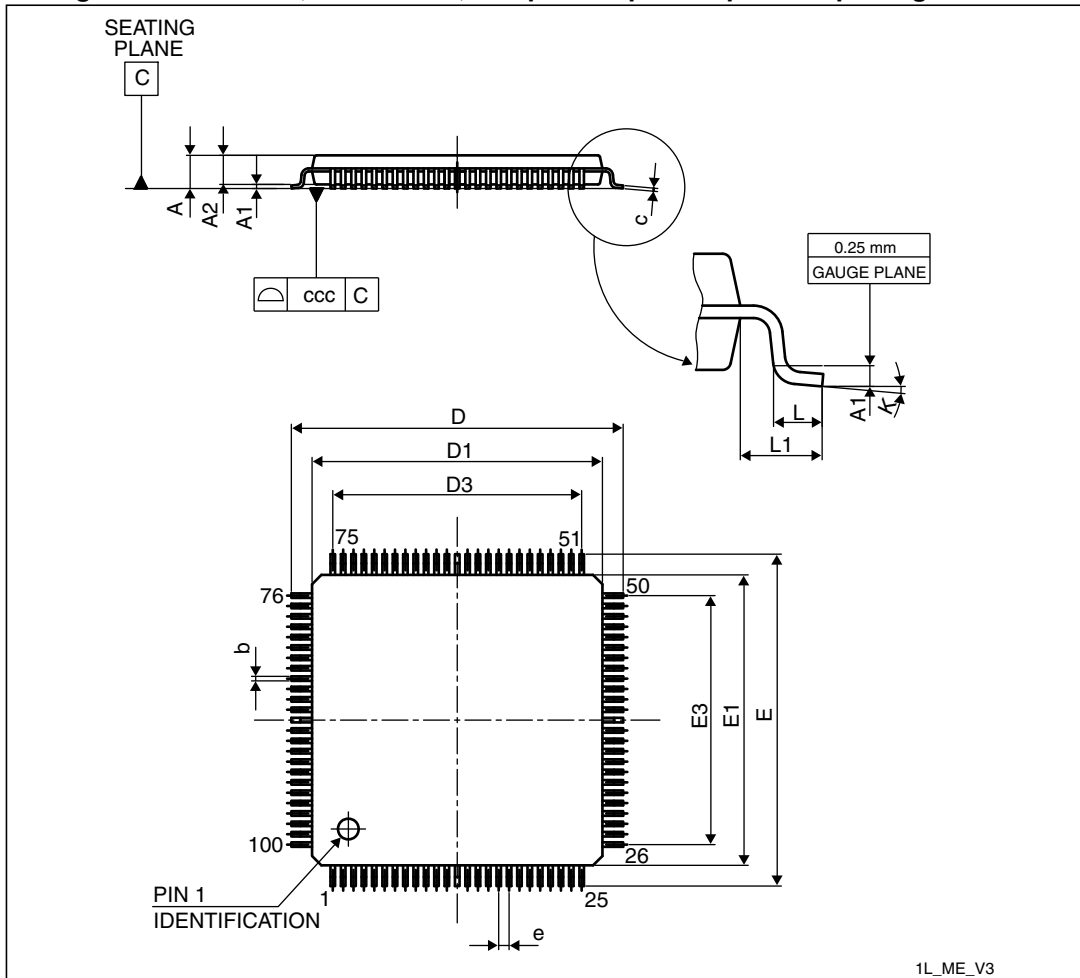

1. Drawing is not to scale.

**Table 74. LQPF100, 14 x 14 mm, 100-pin low-profile quad flat package mechanical data**

Symbol	millimeters			inches <sup>(1)</sup>		
	Min	Typ	Max	Min	Typ	Max
A	-	-	1.600	-	-	0.0630
A1	0.050	-	0.150	0.0020	-	0.0059
A2	1.350	1.400	1.450	0.0531	0.0551	0.0571
b	0.170	0.220	0.270	0.0067	0.0087	0.0106
c	0.090	-	0.200	0.0035	-	0.0079
D	15.800	16.000	16.200	0.6220	0.6299	0.6378
D1	13.800	14.000	14.200	0.5433	0.5512	0.5591
D3	-	12.000	-	-	0.4724	-
E	15.800	16.000	16.200	0.6220	0.6299	0.6378
E1	13.800	14.000	14.200	0.5433	0.5512	0.5591
E3	-	12.000	-	-	0.4724	-
e	-	0.500	-	-	0.0197	-
L	0.450	0.600	0.750	0.0177	0.0236	0.0295
L1	-	1.000	-	-	0.0394	-
k	0.0°	3.5°	7.0°	0.0°	3.5°	7.0°
ccc	-	-	0.080	-	-	0.0031

1. Values in inches are converted from mm and rounded to 4 decimal digits.

**Figure 44. LQFP100 recommended footprint**

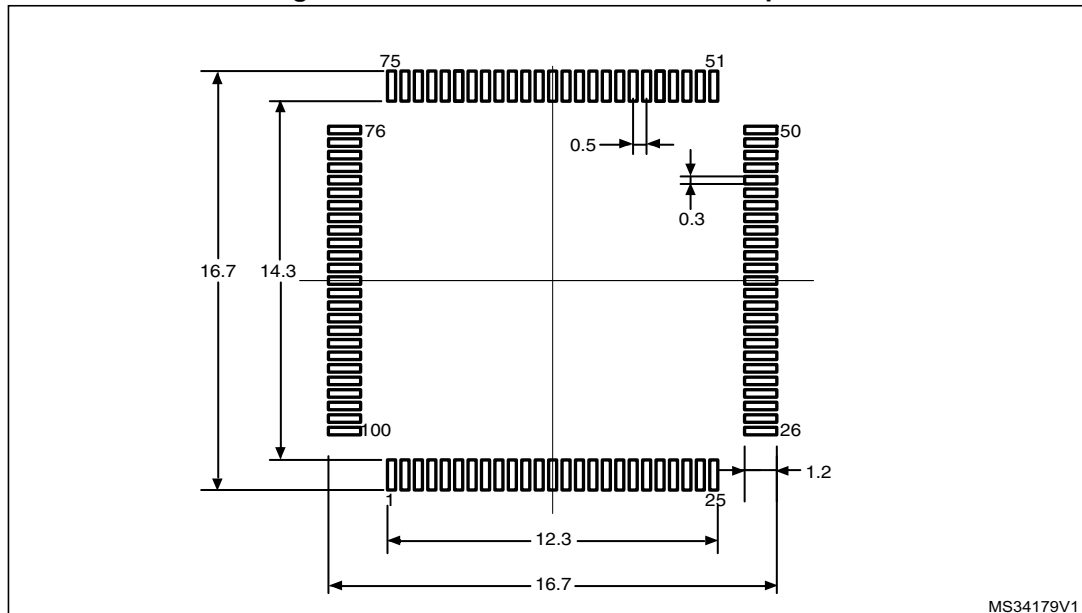

1. Dimensions are in millimeters.

### Marking of engineering samples

The following figure shows the engineering sample marking for the LQFP100 package. Only the information field containing the engineering sample marking is shown.

Figure 45. LQFP100 package top view

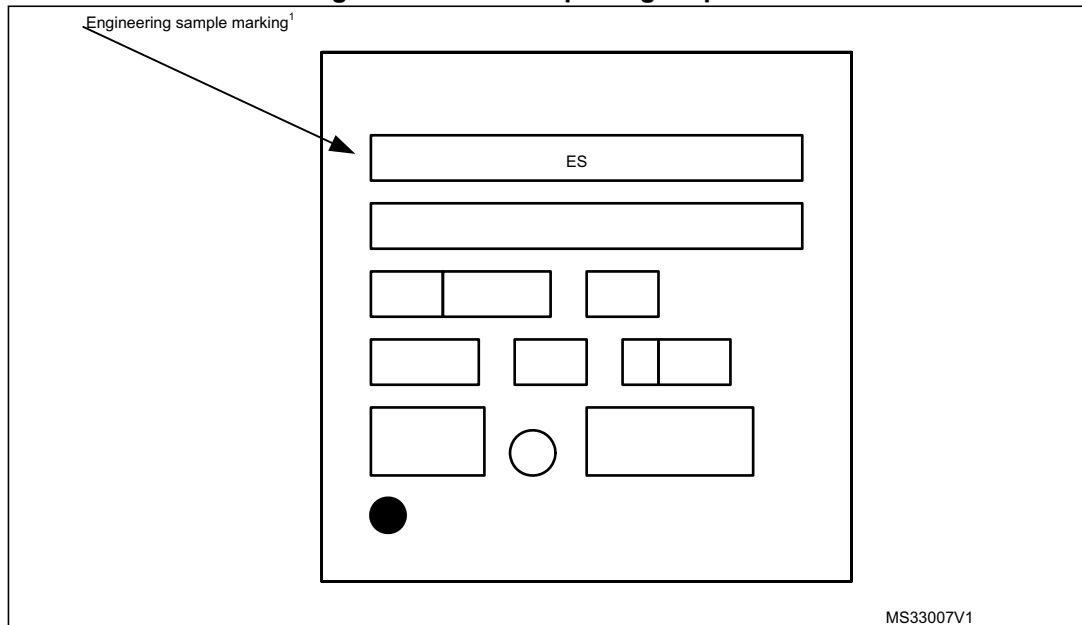

1. Samples marked "ES" are to be considered as "Engineering Samples": i.e. they are intended to be sent to customer for electrical compatibility evaluation and may be used to start customer qualification where specifically authorized by ST in writing. In no event ST will be liable for any customer usage in production. Only if ST has authorized in writing the customer qualification Engineering Samples can be used for reliability qualification trials.

7.1.3 LQFP64, 10 x 10 mm, 64-pin low-profile quad flat package

Figure 46. LQFP64, 10 x 10 mm, 64-pin low-profile quad flat package outline

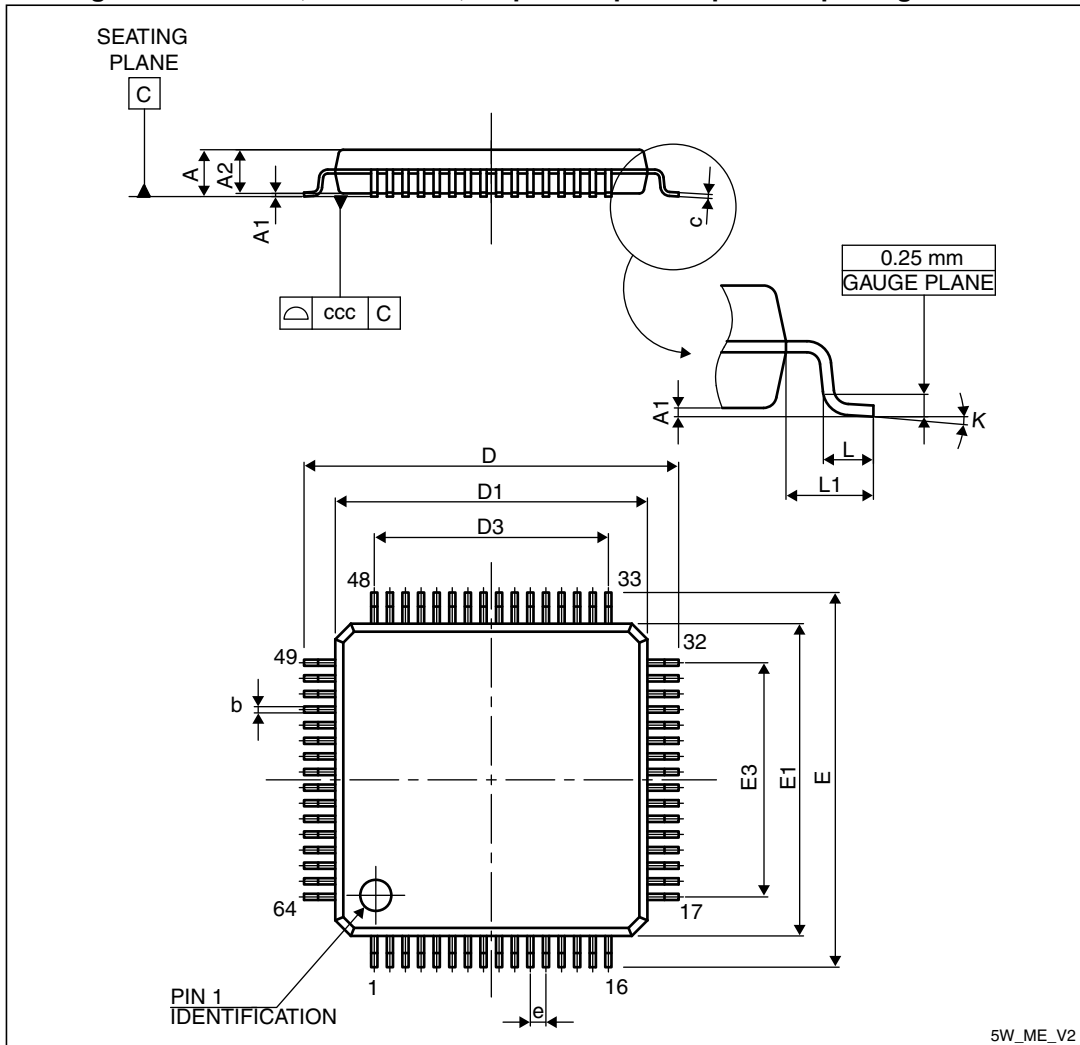

1. Drawing is not to scale.

Table 75. LQFP64, 10 x 10 mm 64-pin low-profile quad flat package mechanical data

Symbol	millimeters			inches <sup>(1)</sup>		
	Min	Typ	Max	Min	Typ	Max
A	-	-	1.600	-	-	0.0630
A1	0.050	-	0.150	0.0020	-	0.0059
A2	1.350	1.400	1.450	0.0531	0.0551	0.0571
b	0.170	0.220	0.270	0.0067	0.0087	0.0106
c	0.090	-	0.200	0.0035	-	0.0079
D	11.800	12.000	12.200	0.4646	0.4724	0.4803
D1	9.800	10.000	10.200	0.3858	0.3937	0.4016
D3	-	7.500	-	-	0.2953	-
E	11.800	12.000	12.200	0.4646	0.4724	0.4803
E1	9.800	10.000	10.200	0.3858	0.3937	0.4016
E3	-	7.500	-	-	0.2953	-
e	-	0.500	-	-	0.0197	-
L	0.450	0.600	0.750	0.0177	0.0236	0.0295
L1	-	1.000	-	-	0.0394	-
ccc	-	-	0.080	-	-	0.0031
K	0.0	3.5	7.0	0.0	3.5	7.0

1. Values in inches are converted from mm and rounded to 4 decimal digits.

Figure 47. LQFP64 recommended footprint

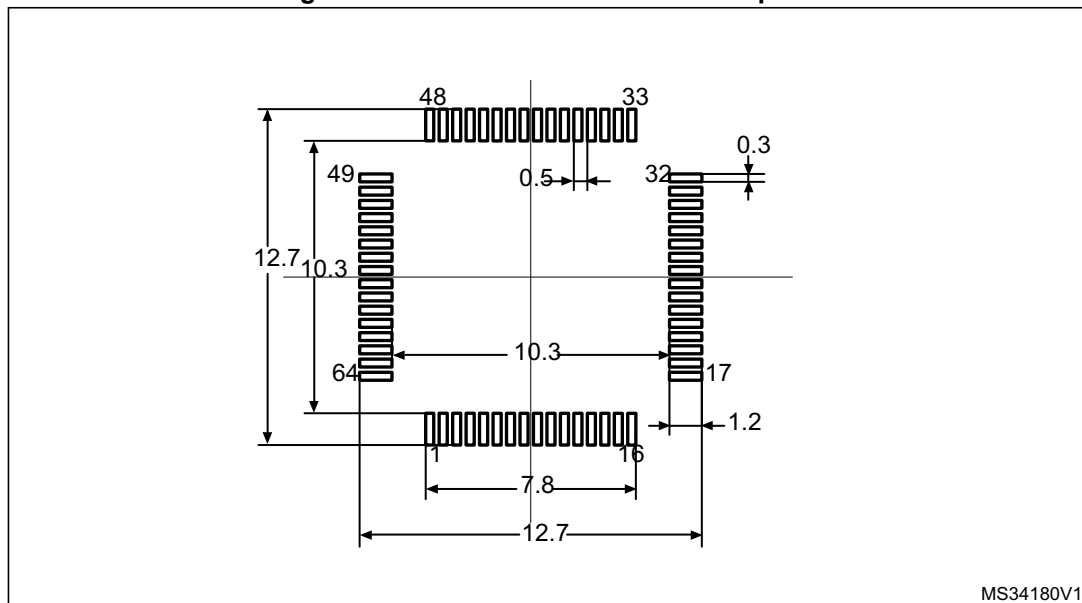

MS34180V1

1. Dimensions are in millimeters.

### Marking of engineering samples

The following figure shows the engineering sample marking for the LQFP64 package. Only the information field containing the engineering sample marking is shown.

Figure 48. LQFP64 package top view

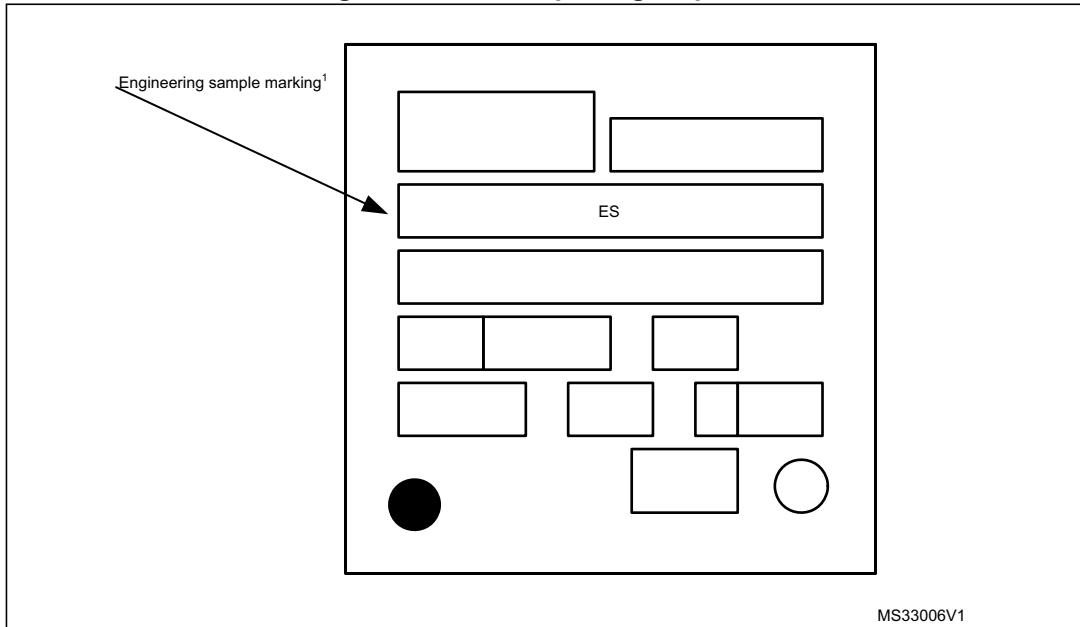

1. Samples marked "ES" are to be considered as "Engineering Samples": i.e. they are intended to be sent to customer for electrical compatibility evaluation and may be used to start customer qualification where specifically authorized by ST in writing. In no event ST will be liable for any customer usage in production. Only if ST has authorized in writing the customer qualification Engineering Samples can be used for reliability qualification trials.

### 7.1.4 UFBGA132, 7 x 7 mm, 132-ball ultra thin, fine-pitch ball grid array package

Figure 49. UFBGA132, 7 x 7 mm, 132-ball ultra thin, fine-pitch ball grid array package outline

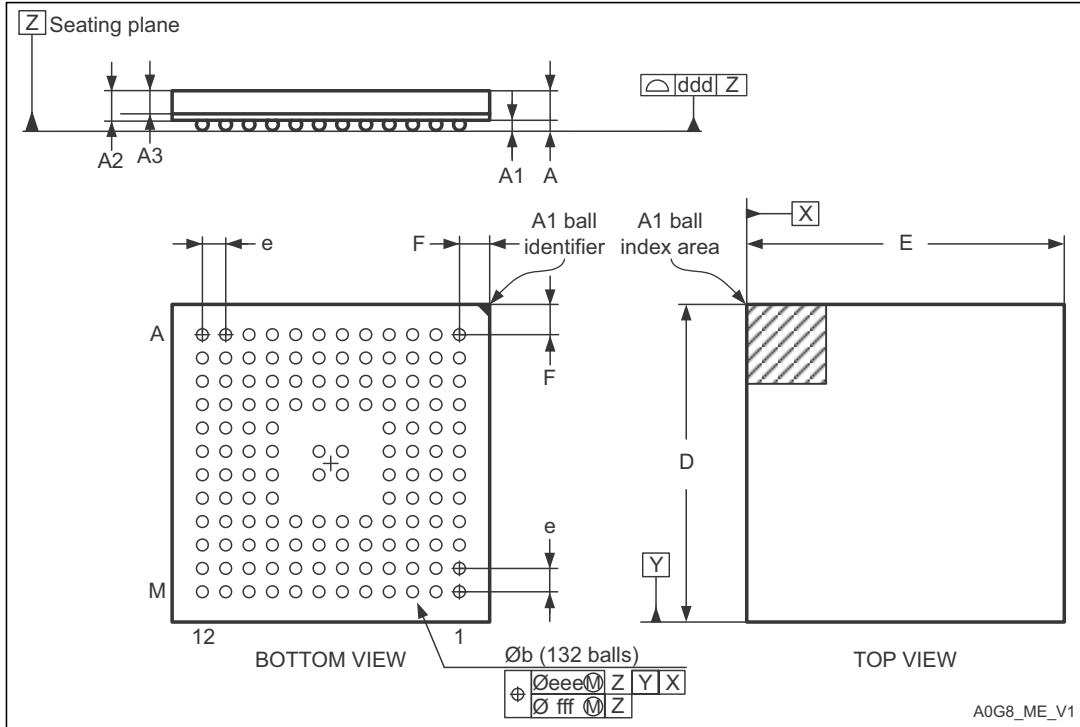

1. Drawing is not to scale.

Table 76. UFBGA132, 7 x 7 mm, 132-ball ultra thin, fine-pitch ball grid array mechanical data

Symbol	millimeters			inches <sup>(1)</sup>		
	Min	Typ	Max	Min	Typ	Max
A	0.460	0.530	0.600	0.0181	0.0209	0.0236
A1	0.050	0.080	0.110	0.0020	0.0031	0.0043
A2	0.400	0.450	0.500	0.0157	0.0177	0.0197
A3	0.270	0.320	0.370	0.0106	0.0126	0.0146
b	0.170	0.280	0.330	0.0067	0.0110	0.0130
D	6.950	7.000	7.050	0.2736	0.2756	0.2776
E	6.950	7.000	7.050	0.2736	0.2756	0.2776
e	-	0.500	-	-	0.0197	-
F	0.700	0.750	0.800	0.0276	0.0295	0.0315
ddd	-	-	0.080	-	-	0.0031

**Table 76. UFBGA132, 7 x 7 mm, 132-ball ultra thin, fine-pitch ball grid array mechanical data (continued)**

Symbol	millimeters			inches <sup>(1)</sup>		
	Min	Typ	Max	Min	Typ	Max
eee	-	-	0.150	-	-	0.0059
fff	-	-	0.050	-	-	0.0020

1. Values in inches are converted from mm and rounded to 4 decimal digits.

**Figure 50. UFBGA132 recommended footprint**

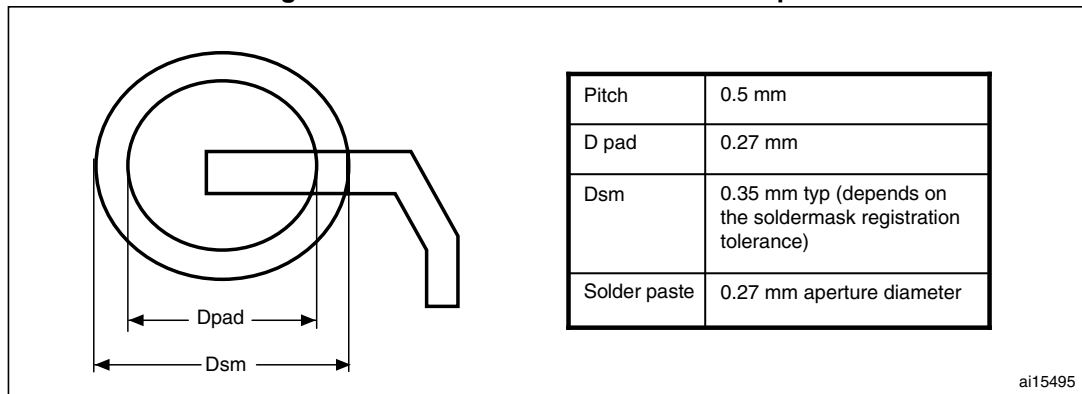

**Marking of engineering samples**

The following figure shows the engineering sample marking for the UFBGA132 package. Only the information field containing the engineering sample marking is shown.

**Figure 51. UFBGA132 package top view**

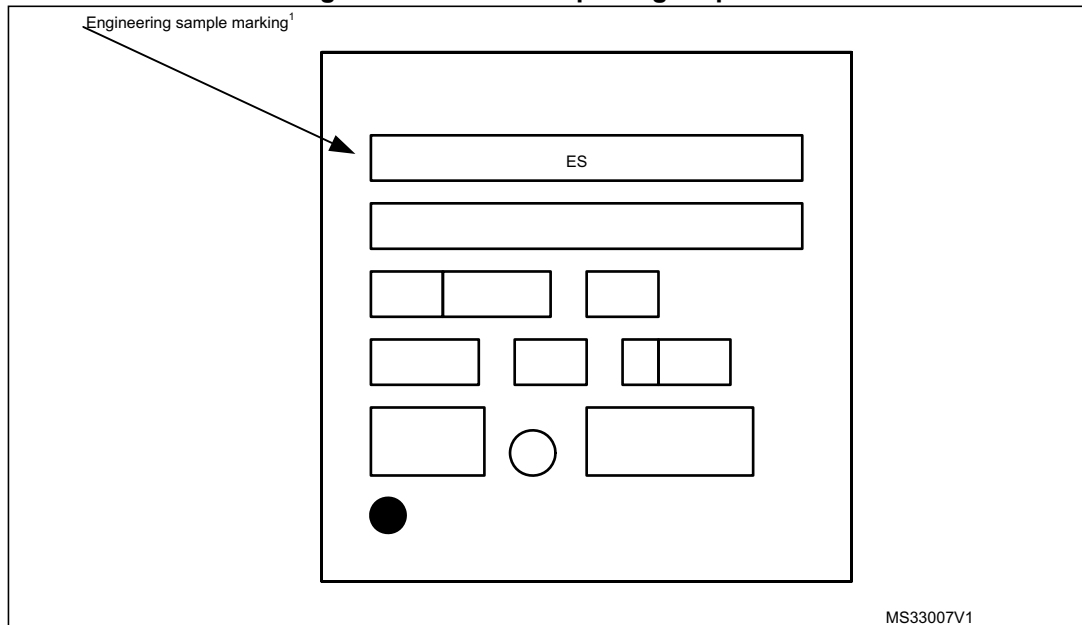

1. Samples marked "ES" are to be considered as "Engineering Samples": i.e. they are intended to be sent to customer for electrical compatibility evaluation and may be used to start customer qualification where

specifically authorized by ST in writing. In no event ST will be liable for any customer usage in production. Only if ST has authorized in writing the customer qualification Engineering Samples can be used for reliability qualification trials.

7.1.5 WLCSP64, 0.400 mm pitch wafer level chip size package

Figure 52. WLCSP64, 0.400 mm pitch wafer level chip size package outline

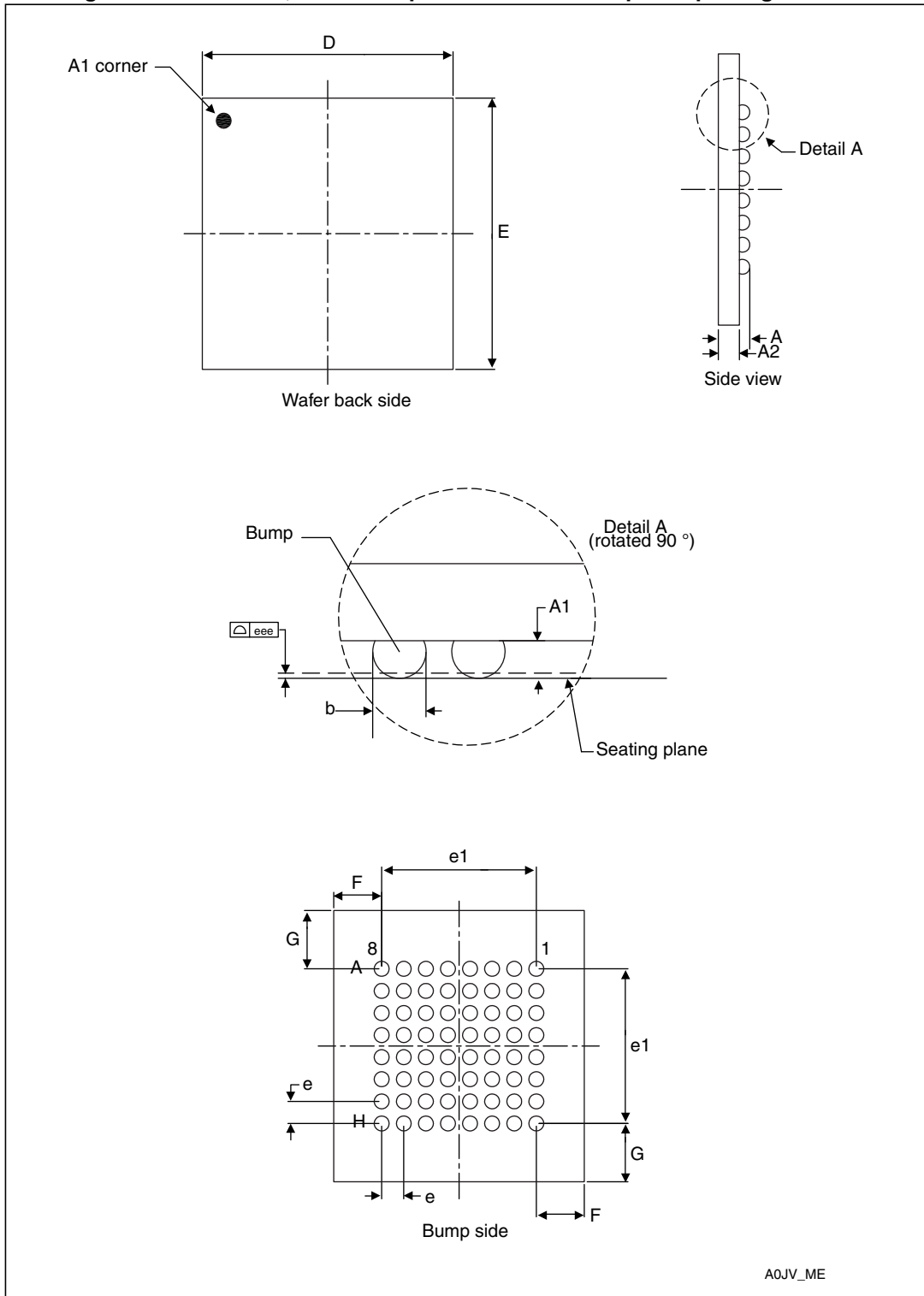

1. Drawing is not to scale.

**Table 77. WLCSP64, 0.400 mm pitch wafer level chip size package mechanical data**

Symbol	millimeters			inches <sup>(1)</sup>		
	Min	Typ	Max	Min	Typ	Max
A	0.540	0.570	0.600	0.0205	0.0224	0.0244
A1		0.19		0.0067	0.0075	0.0083
A2		0.380		0.0138	0.0150	0.0161
b	0.240	0.270	0.300	0.0094	0.0106	0.0118
D	4.504	4.539	4.574	0.1779	0.1787	0.1795
E	4.876	4.911	4.946	0.1926	0.1933	0.1941
e		0.400			0.0157	
e1		2.800			0.1102	
F		0.870			0.0343	
G		1.056			0.0416	
eee			0.050			0.0020

1. Values in inches are converted from mm and rounded to 4 decimal digits.

**Figure 53. WLCSP64 package top view**

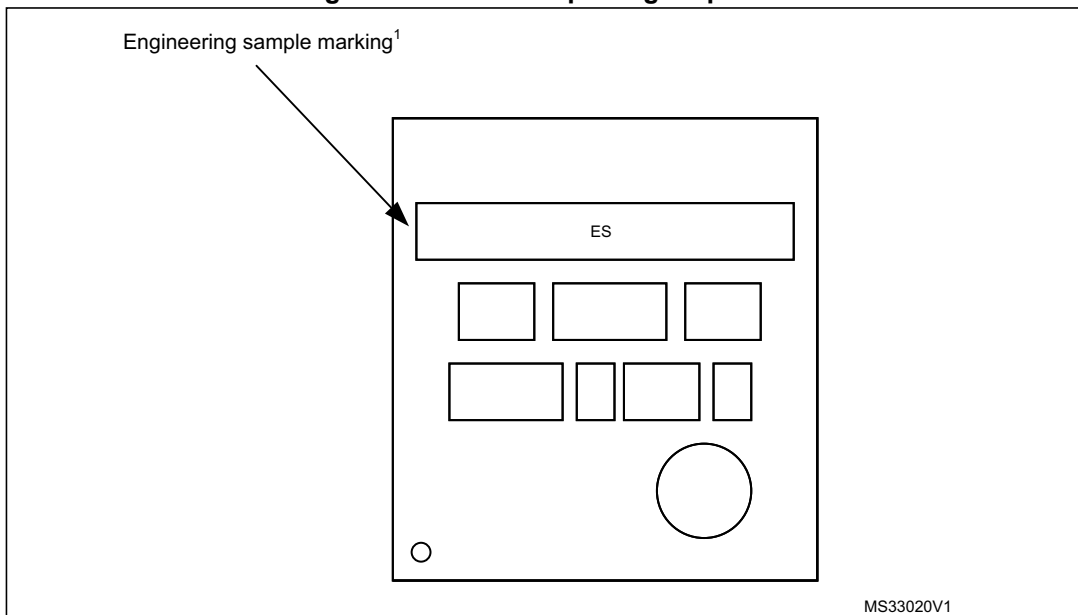

1. Samples marked “ES” are to be considered as “Engineering Samples”: i.e. they are intended to be sent to customer for electrical compatibility evaluation and may be used to start customer qualification where specifically authorized by ST in writing. In no event ST will be liable for any customer usage in production. Only if ST has authorized in writing the customer qualification Engineering Samples can be used for reliability qualification trials.

## 7.2 Thermal characteristics

The maximum chip-junction temperature,  $T_J \text{ max}$ , in degrees Celsius, may be calculated using the following equation:

$$T_J \text{ max} = T_A \text{ max} + (P_D \text{ max} \times \Theta_{JA})$$

Where:

- $T_A \text{ max}$  is the maximum ambient temperature in °C,
- $\Theta_{JA}$  is the package junction-to-ambient thermal resistance, in °C/W,
- $P_D \text{ max}$  is the sum of  $P_{INT} \text{ max}$  and  $P_{I/O} \text{ max}$  ( $P_D \text{ max} = P_{INT} \text{ max} + P_{I/O} \text{ max}$ ),
- $P_{INT} \text{ max}$  is the product of  $I_{DD}$  and  $V_{DD}$ , expressed in Watts. This is the maximum chip internal power.

$P_{I/O} \text{ max}$  represents the maximum power dissipation on output pins where:

$$P_{I/O} \text{ max} = \Sigma (V_{OL} \times I_{OL}) + \Sigma ((V_{DD} - V_{OH}) \times I_{OH}),$$

taking into account the actual  $V_{OL} / I_{OL}$  and  $V_{OH} / I_{OH}$  of the I/Os at low and high level in the application.

**Table 78. Thermal characteristics**

Symbol	Parameter	Value	Unit
$\Theta_{JA}$	<b>Thermal resistance junction-ambient</b> LQFP144 - 20 x 20 mm / 0.5 mm pitch	40	°C/W
	<b>Thermal resistance junction-ambient</b> UFBGA132 - 7 x 7 mm	60	
	<b>Thermal resistance junction-ambient</b> LQFP100 - 14 x 14 mm / 0.5 mm pitch	43	
	<b>Thermal resistance junction-ambient</b> LQFP64 - 10 x 10 mm / 0.5 mm pitch	46	
	<b>Thermal resistance junction-ambient</b> WLCSP64 - 0.400 mm pitch	46	

Figure 54. Thermal resistance suffix 6

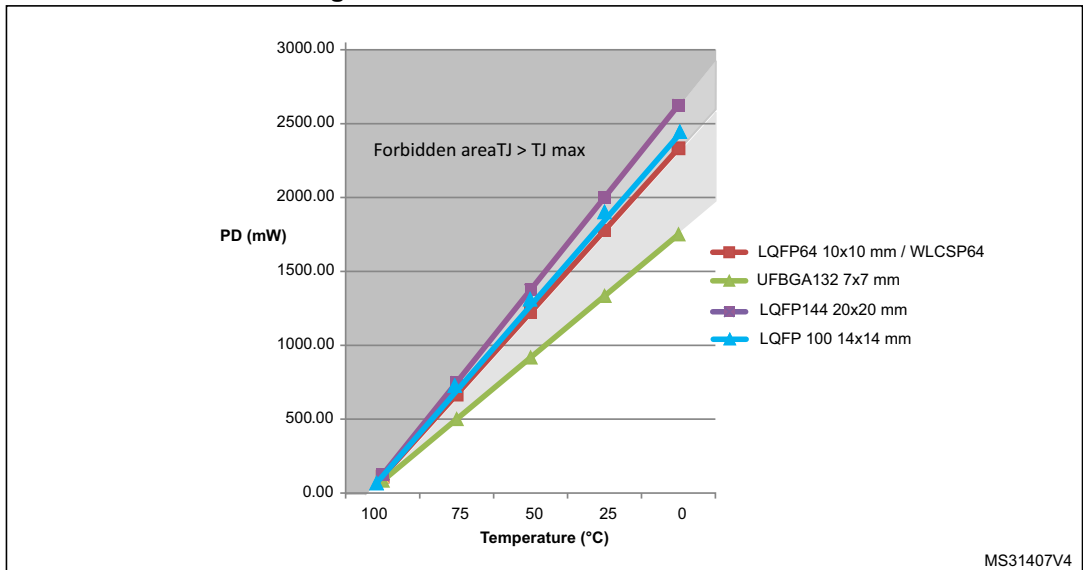
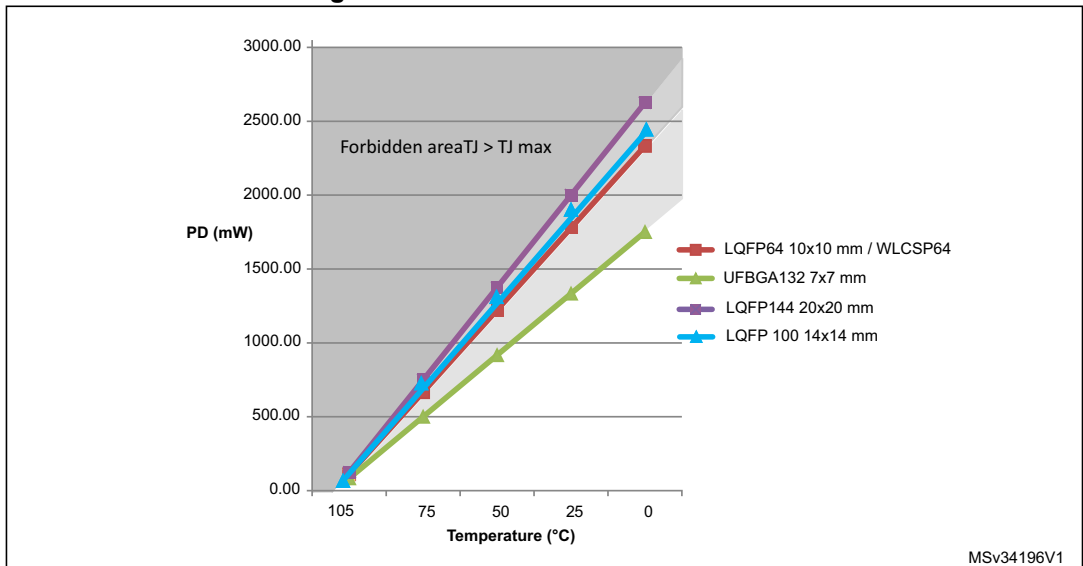

Figure 55. Thermal resistance suffix 7



7.2.1 Reference document

JESD51-2 Integrated Circuits Thermal Test Method Environment Conditions - Natural Convection (Still Air). Available from [www.jedec.org](http://www.jedec.org).

# 8 Part numbering

**Table 79. STM32L162xD ordering information scheme**

Example:	STM32	L	162	V	D	T	6	D	xxx
<b>Device family</b>	STM32 = ARM-based 32-bit microcontroller								
<b>Product type</b>	L = Low-power								
<b>Device subfamily</b>	162: Devices with LCD								
<b>Pin count</b>	R = 64 pins V = 100 pins Z = 144 pins Q = 132 pins								
<b>Flash memory size</b>	D = 384 Kbytes of Flash memory								
<b>Package</b>	H = BGA T = LQFP Y = WLCSP64								
<b>Temperature range</b>	6 = Industrial temperature range, -40 to 85 °C 7 = Industrial temperature range, -40 to 105 °C								
<b>Options</b>	No character = V <sub>DD</sub> range: 1.8 to 3.6 V and BOR enabled D = V <sub>DD</sub> range: 1.65 to 3.6 V and BOR disabled								
<b>Packing</b>	TR = tape and reel No character = tray or tube								

For a list of available options (speed, package, etc.) or for further information on any aspect of this device, please contact your nearest ST sales office.

## 9 Revision History

**Table 80. Document revision history**

Date	Revision	Changes
24-Oct-2011	1	Initial release.
28-Feb-2012	2	<p>Status of the document changed (datasheet instead of preliminary data).</p> <p>Added STM32L162RD part number.</p> <p>Added LQFP64 and WLCSP64 packages.</p> <p>Updated “Low power ” and “Memory” feature on page 1.</p> <p><i>Introduction</i> and <i>Description</i>: added ‘high density’.</p> <p>GPIOF replaced with GIOPH.</p> <p>Added SDIO in <i>Table 5: Ultralow power STM32L162xD device features and peripheral counts on page 13</i>.</p> <p><i>Section 3: Functional overview</i>: changed ‘128 kHz’ to ‘131 kHz’ in section “Low power run mode”.</p> <p><i>Section 3.16: AES</i>: updated ‘214’ to ‘213’ clock cycles.</p> <p><i>Section 3.17.1: General-purpose timers (TIM2, TIM3, TIM4, TIM5, TIM9, TIM10 and TIM11)</i>: changed ‘six’ to ‘seven’ synchronizable general-purpose timers.</p> <p>Added SDIO in <i>Table 19: Alternate function input/output on page 86</i> (FSMC/SDIO instead of FSMC); modified alternate function for PA13 and PA14; removed EVENT OUT for PH2.</p> <p>Modified <i>Section 3.4: Clock management on page 20</i>.</p> <p><i>Table 15: STM32L162xD pin definitions on page 60</i>: updated name of reference manual in footnote 4.</p> <p>Modified <i>Figure 8: Power supply scheme on page 46</i>.</p> <p>Modified <i>Table 2: Functionalities depending on the operating power supply range on page 15</i>.</p> <p><i>Table 18: Current consumption in Run mode, code with data processing running from RAM</i>: added footnote 3.</p> <p><i>Table 19: Current consumption in Sleep mode</i>: updated condition for <math>f_{HSE}</math>; added footnote 3.</p> <p><i>Table 23: Typical and maximum current consumptions in Standby mode</i>: modified max values.</p> <p><i>Table 28: Peripheral current consumption</i>: added AES.</p> <p><i>Table 64: USB DC electrical characteristics</i>: removed two footnotes.</p> <p>Modified <i>Table 38: Flash memory and data EEPROM characteristics on page 83</i>.</p> <p>Modified tables in <i>Section 6.3.4: Supply current characteristics on page 54</i>.</p>

Table 80. Document revision history (continued)

Date	Revision	Changes
25-Oct-2012	3	<p>Updated <i>Section 3.10: ADC (analog-to-digital converter)</i> to add <i>Section 3.10.1: Temperature sensor</i> and <i>Section 3.10.2: Internal voltage reference (VREFINT)</i>.</p> <p>Updated <i>Figure 1: Ultra-low-power STM32L162xC block diagram</i></p> <p>Added <i>Table 4: Functionalities depending on the working mode (from Run/active down to standby)</i>, and <i>Table 3: ange depending on dynamic voltage scaling</i></p> <p>Updated <i>Figure 3: STM32L162VC LQFP100 pinout</i></p> <p>Changed FSMC_LBAR into FSMC_NADV, and I2C1_SMBAI into I2C1_SMBA in <i>Table 15: STM32L162xD pin definitions</i>.</p> <p>Modified PB10/11/12 for AFIO4 alternate function, and replaced LBAR by NADV for AFIO12 in <i>Table 19: Alternate function input/output</i>.</p> <p>Removed caution note below <i>Figure 8: Power supply scheme</i>.</p> <p>Added <i>Note 2</i> in <i>Table 15: Embedded reset and power control block characteristics</i></p> <p>Updated <i>Table 22: Typical and maximum current consumptions in Stop mode</i> and added <i>Note 6</i>. Updated <i>Table 23: Typical and maximum current consumptions in Standby mode</i>. Updated <math>t_{WUSTOP}</math> in <i>Table .</i></p> <p>Updated <i>Table 28: Peripheral current consumption</i>.</p> <p>Updated <i>Table 60: SPI characteristics</i>, added <i>Note 1</i> and <i>Note 3</i>, and applied <i>Note 2</i> to <math>t_{r(SCK)}</math>, <math>t_{f(SCK)}</math>, <math>t_{w(SCKH)}</math>, <math>t_{w(SCKL)}</math>, <math>t_{su(MI)}</math>, <math>t_{su(SI)}</math>, <math>t_{h(MI)}</math>, and <math>t_{h(SI)}</math>.</p> <p>Added <i>Table 61: I2S characteristics, Figure 29: I2S slave timing diagram (Philips protocol)(1)</i> and <i>Figure 30: I2S master timing diagram (Philips protocol)(1)</i></p> <p>Added <i>Table 62: SDIO characteristics</i></p> <p>Added <i>Table 31: SDIO timings</i></p> <p>Updated <i>Table 72: Temperature sensor characteristics</i></p> <p>Added <i>Figure 40: Thermal resistance</i></p>

Table 80. Document revision history (continued)

Date	Revision	Changes
06-Feb-2013	4	<p>Removed AHB1/AHB2 and corrected typo on APB1/APB2 in <i>Figure 1: Ultra-low-power STM32L162xC block diagram</i></p> <p>Updated “OP amp” line in <i>Table 4: Functionalities depending on the working mode (from Run/active down to standby)</i></p> <p>Added IWDG and WWDG rows in <i>Table 4: Functionalities depending on the working mode (from Run/active down to standby)</i></p> <p>Added OneNAND support in <i>Section 3.8: FSMC (flexible static memory controller)</i></p> <p>The comment "HSE = 16 MHz(2) (PLL ON for fHCLK above 16 MHz)" replaced by "fHSE = fHCLK up to 16 MHz included, fHSE = fHCLK/2 above 16 MHz (PLL ON)(2)" in <i>table Table 19: Current consumption in Sleep mode</i></p> <p>Updated Stop mode current to 1.5 <math>\mu</math>A in <i>Ultra-low-power platform</i></p> <p>Replaced BGA132 by UFBGA132 in <i>Table 5: Ultralow power STM32L162xD device features and peripheral counts</i></p> <p>Replaced BGA132 by UFBGA132 in <i>Figure 4: STM32L15xQD STM32L162QD UFBGA132 ballout</i></p> <p>Updated entire <i>Section 7: Package characteristics</i></p> <p>Updated <i>Figure 34: Typical connection diagram using the ADC</i> and definition of symbol “R<sub>AIN</sub>” in <i>Table 67: ADC characteristics</i></p> <p>Removed first sentence in <i>Section : I2C interface characteristics</i></p>
13-June-2014	5	<p>Updated <i>Table 14: Embedded internal reference voltage calibration values</i> and moved inside <i>Section 6.3.3: Embedded internal reference voltage</i>.</p> <p>Updated I<sub>DD</sub> (WU from Standby) unit in <i>Table 22: Typical and maximum current consumptions in Standby mode</i></p> <p>Updated <i>Figure 9: Pin loading conditions</i></p> <p>Updated <i>Figure 10: Pin input voltage</i>.</p> <p>Updated <i>Figure 17: Typical application with a 32.768 kHz crystal</i>/Updated <i>Figure 27: Recommended NRST pin protection</i></p> <p>Updated <i>Figure 28: I2C bus AC waveforms and measurement circuit</i></p> <p>Updated <i>Table 68: Temperature sensor calibration values</i> and moved inside <i>Section 6.3.22: Temperature sensor characteristics..</i></p> <p>Updated <i>Figure 11: Power supply scheme</i>.</p> <p>Updated <i>Table 9: Voltage characteristics</i> added row.</p> <p>Updated <i>Table 10: Current characteristics</i>.</p> <p>Updated <i>Table 12: General operating conditions</i>, footnote and added row.</p> <p>Updated <i>Section 6.3.4: Supply current characteristics</i>.</p> <p>Updated <i>Table 16: Current consumption in Run mode, code with data processing running from Flash</i>.</p> <p>Updated <i>Table 17: Current consumption in Run mode, code with data processing running from RAM</i>.</p> <p>Created <i>Section 6.3.5: Wakeup time from low-power mode</i>.</p> <p>Updated <i>Table 75: LQFP64, 10 x 10 mm 64-pin low-profile quad flat package mechanical data</i> and <i>Table 76: UFBGA132, 7 x 7 mm, 132-ball ultra thin, fine-pitch ball grid array mechanical data</i> exchange Min and Typ values inside columns.</p>

Table 80. Document revision history (continued)

Date	Revision	Changes
13-June-2014	5	<p>Added <math>V_{DD} = 1.71</math> to 1.8 V operating power supply range in <a href="#">Table 2: Functionalities depending on the operating power supply range</a></p> <p>Updated “SDA data hold time” and “SDA and SCL rise time” values and added “Pulse width of spikes that are suppressed by the analog filter” row in <a href="#">Table 54: I2C characteristics</a>.</p> <p>Added Input Voltage in <a href="#">Table 12: General operating conditions</a>.</p> <p>Modified <math>t_{LOCK}</math> values in <a href="#">Table 32: PLL characteristics</a>.</p> <p>Updated <a href="#">Table 49: I/O static characteristics</a>. Updated conditions in <a href="#">Table 50: Output voltage characteristics</a>.</p> <p>Removed minimum values for <math>f_S</math> in <a href="#">Table 63: ADC characteristics</a>.</p> <p>Updated <a href="#">Figure 37: Typical connection diagram using the ADC</a>.</p> <p>Updated <a href="#">Table 68: Temperature sensor calibration values</a>. Removed figures “Power supply and reference decoupling (<math>V_{REF+}</math> not connected to <math>V_{DDA}</math>) and “Power supply and reference decoupling (<math>V_{REF+}</math> connected to <math>V_{DDA}</math>). Removed note 4 in <a href="#">Table 69: Temperature sensor characteristics</a>.</p> <p>Updated <a href="#">Table 66: DAC characteristics</a></p> <p>Added <a href="#">Table 50: UFBGA132 recommended footprint</a>.</p> <p>Updated the conditions in <a href="#">Table 24: Low-power mode wakeup timings</a>.</p> <p>Removed ambiguity of “ambient temperature” in the electrical characteristics description.</p>
23-Oct-2014	6	<p>Updated <a href="#">Section 3.19: Communication interfaces</a> putting I2S characteristics inside.</p> <p>Updated DMIPS features in cover page and <a href="#">Section 2: Description</a>.</p> <p>Updated max temperature at 105°C instead of 85°C in the whole datasheet.</p> <p>Updated current consumption in <a href="#">Table 18: Current consumption in Sleep mode</a>.</p> <p>Updated <a href="#">Table 23: Peripheral current consumption</a> with new measured current values.</p> <p>Updated <a href="#">Table 65: Maximum source impedance RAIN max</a> adding note 2.</p>

**IMPORTANT NOTICE – PLEASE READ CAREFULLY**

STMicroelectronics NV and its subsidiaries (“ST”) reserve the right to make changes, corrections, enhancements, modifications, and improvements to ST products and/or to this document at any time without notice. Purchasers should obtain the latest relevant information on ST products before placing orders. ST products are sold pursuant to ST’s terms and conditions of sale in place at the time of order acknowledgement.

Purchasers are solely responsible for the choice, selection, and use of ST products and ST assumes no liability for application assistance or the design of Purchasers’ products.

No license, express or implied, to any intellectual property right is granted by ST herein.

Resale of ST products with provisions different from the information set forth herein shall void any warranty granted by ST for such product.

ST and the ST logo are trademarks of ST. All other product or service names are the property of their respective owners.

Information in this document supersedes and replaces information previously supplied in any prior versions of this document.

© 2014 STMicroelectronics – All rights reserved