



# STB160N75F3 STP160N75F3 - STW160N75F3

N-channel 75V - 3.5mΩ - 120A - TO-220 - TO-247 - D<sup>2</sup>PAK  
STripFET™ Power MOSFET

## Features

Type	V <sub>DSS</sub>	R <sub>DS(on)</sub> (max.)	I <sub>D</sub>
STB160N75F3	75V	3.7 mΩ	120 A <sup>(1)</sup>
STP160N75F3	75V	4 mΩ	120 A <sup>(1)</sup>
STW160N75F3	75V	4 mΩ	120 A <sup>(1)</sup>

1. Current limited by package

- Ultra low on-resistance
- 100% Avalanche tested

## Application

- Switching applications

## Description

This N-channel enhancement mode Power MOSFET is the latest refinement of ST's STripFET™ process. The resulting transistor shows extremely high packing density for low on resistance, rugged avalanche characteristics and low gate charge.

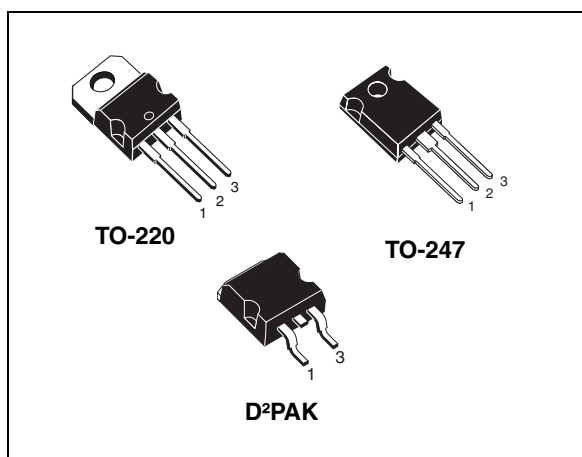

Figure 1. Internal schematic diagram

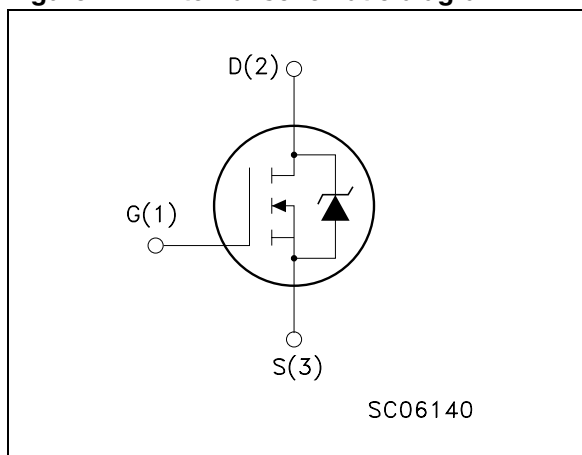

Table 1. Device summary

Order codes	Marking	Package	Packaging
STB160N75F3	160N75F3	D <sup>2</sup> PAK	Tape & reel
STP160N75F3	160N75F3	TO-220	Tube
STW160N75F3	160N75F3	TO-247	Tube

# Contents

<b>1</b>	<b>Electrical ratings</b> .....	<b>3</b>
<b>2</b>	<b>Electrical characteristics</b> .....	<b>4</b>
2.1	Electrical characteristics (curves) .....	6
<b>3</b>	<b>Test circuit</b> .....	<b>9</b>
<b>4</b>	<b>Package mechanical data</b> .....	<b>10</b>
<b>5</b>	<b>Packaging mechanical data</b> .....	<b>14</b>
<b>6</b>	<b>Revision history</b> .....	<b>15</b>

# 1 Electrical ratings

**Table 2. Absolute maximum ratings**

Symbol	Parameter	Value	Unit
$V_{DS}$	Drain-source voltage ( $V_{GS} = 0$ )	75	V
$V_{GS}$	Gate-source voltage	$\pm 20$	V
$I_D^{(1)}$	Drain current (continuous) at $T_C = 25^\circ\text{C}$	120	A
$I_D^{(1)}$	Drain current (continuous) at $T_C = 100^\circ\text{C}$	120	A
$I_{DM}^{(2)}$	Drain current (pulsed)	480	A
$P_{TOT}$	Total dissipation at $T_C = 25^\circ\text{C}$	330	W
	Derating factor	2.2	W/ $^\circ\text{C}$
$dv/dt^{(3)}$	Peak diode recovery voltage slope	20	V/ns
$E_{AS}^{(4)}$	Single pulse avalanche energy	600	mJ
$T_j$ $T_{stg}$	Operating junction temperature Storage temperature	-55 to 175	$^\circ\text{C}$

1. Current limited by package
2. Pulse width limited by safe operating area
3.  $I_{SD} \leq 120\text{A}$ ,  $di/dt \leq 1100\text{ A}/\mu\text{s}$ ,  $V_{DD} \leq 60\text{V}$ ,  $T_J \leq T_{JMAX}$
4. Starting  $T_J = 25^\circ\text{C}$ ,  $I_D = 60\text{A}$ ,  $V_{DD} = 25\text{V}$

**Table 3. Thermal resistance**

Symbol	Parameter	Value			Unit
		TO-220	TO-247	D <sup>2</sup> PAK	
$R_{thj-case}$	Thermal resistance junction-case max	0.45			$^\circ\text{C}/\text{W}$
$R_{thj-amb}$	Thermal resistance junction-ambient max	62.5	50	--	$^\circ\text{C}/\text{W}$
$R_{thj-pcb}^{(1)}$	Thermal resistance junction-pcb	--	--	50	$^\circ\text{C}/\text{W}$
$T_l$	Maximum lead temperature for soldering purpose	300			$^\circ\text{C}$

1. When mounted on 1 inch<sup>2</sup> FR4 2 oz Cu

## 2 Electrical characteristics

( $T_{CASE}=25^{\circ}C$  unless otherwise specified)

**Table 4. On/off states**

Symbol	Parameter	Test conditions	Min.	Typ.	Max	Unit
$V_{(BR)DSS}$	Drain-source breakdown voltage	$I_D = 250\mu A, V_{GS} = 0$	75			V
$I_{DSS}$	Zero gate voltage drain current ( $V_{GS} = 0$ )	$V_{DS} = \text{Max rating},$ $V_{DS} = \text{Max rating}, @ 125^{\circ}C$			10 100	$\mu A$ $\mu A$
$I_{GSS}$	Gate body leakage current ( $V_{DS} = 0$ )	$V_{GS} = \pm 20V$			$\pm 200$	nA
$V_{GS(th)}$	Gate threshold voltage	$V_{DS} = V_{GS}, I_D = 250\mu A$	2		4	V
$R_{DS(on)}$	Static drain-source on resistance	$V_{GS} = 10V, I_D = 60A$		3.5 3.2	4 3.7	$m\Omega$ $m\Omega$

**Table 5. Dynamic**

Symbol	Parameter	Test conditions	Min	Typ	Max	Unit
$C_{iss}$	Input capacitance	$V_{DS} = 25V, f = 1 \text{ MHz}, V_{GS} = 0$		6750		pF
$C_{oss}$	Output capacitance			1080		pF
$C_{rss}$	Reverse transfer capacitance			40		pF
$Q_g$	Total gate charge	$V_{DD} = 37.5V, I_D = 120A$		85		nC
$Q_{gs}$	Gate-source charge	$V_{GS} = 10V$		27		nC
$Q_{gd}$	Gate-drain charge	(see Figure 16)		26		nC

**Table 6. Switching times**

Symbol	Parameter	Test conditions	Min.	Typ.	Max.	Unit
$t_{d(on)}$	Turn-on delay time	$V_{DD}=37.5\text{ V}$ , $I_D=60\text{ A}$ , $R_G=4.7\Omega$ , $V_{GS}=10\text{ V}$ , (see Figure 18)		22		ns
$t_r$	Rise time			65		ns
$t_{d(off)}$	Turn-off delay time			100		ns
$t_f$	Fall time			15		ns

**Table 7. Source drain diode**

Symbol	Parameter	Test conditions	Min.	Typ.	Max.	Unit
$I_{SD}$	Source-drain current				120	A
$I_{SDM}^{(1)}$	Source-drain current (pulsed)				480	A
$V_{SD}^{(2)}$	Forward on voltage	$I_{SD}=120\text{ A}$ , $V_{GS}=0$			1.5	V
$t_{rr}$	Reverse recovery time	$I_{SD}=120\text{ A}$ , $V_{DD}=20\text{ V}$ , $di/dt = 100\text{ A}/\mu\text{s}$ , $T_j=25^\circ\text{C}$ (see Figure 17)		70		ns
$Q_{rr}$	Reverse recovery charge			150		nC
$I_{RRM}$	Reverse recovery current			4.2		A

1. Pulse with limited by safe operating area
2. Pulsed: pulse duration = 300 $\mu\text{s}$ , duty cycle 1.5%

## 2.1 Electrical characteristics (curves)

Figure 2. Safe operating area for TO-220 / TO-247

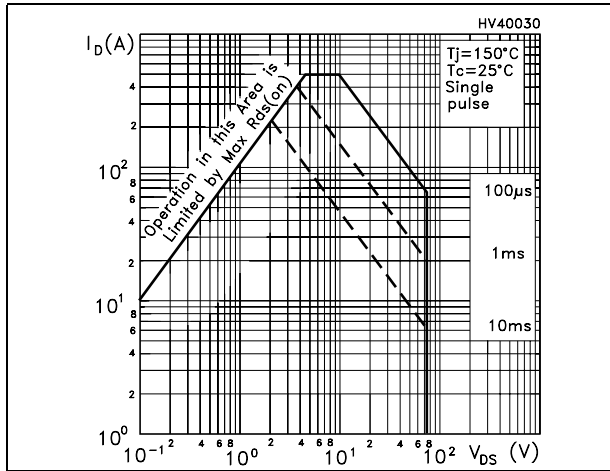

Figure 3. Thermal impedance for TO-220 / TO-247

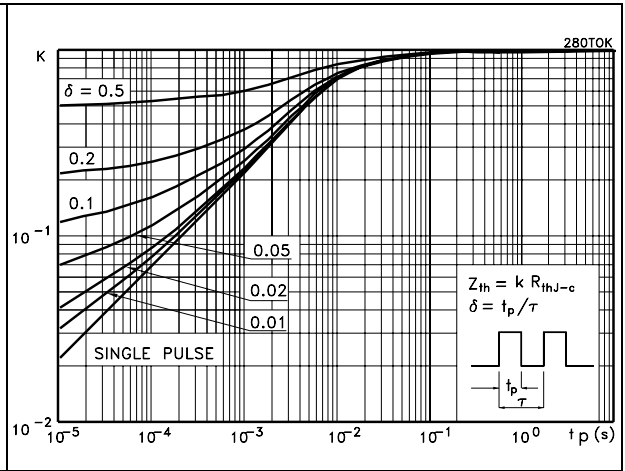

Figure 4. Safe operating area for D<sup>2</sup>PAK

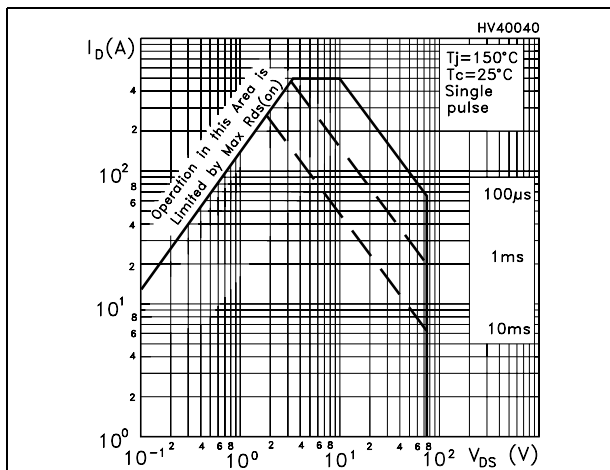

Figure 5. Thermal impedance for D<sup>2</sup>PAK

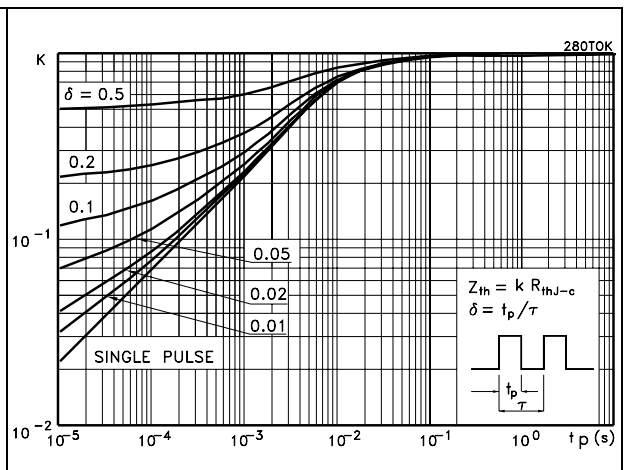

Figure 6. Output characteristics

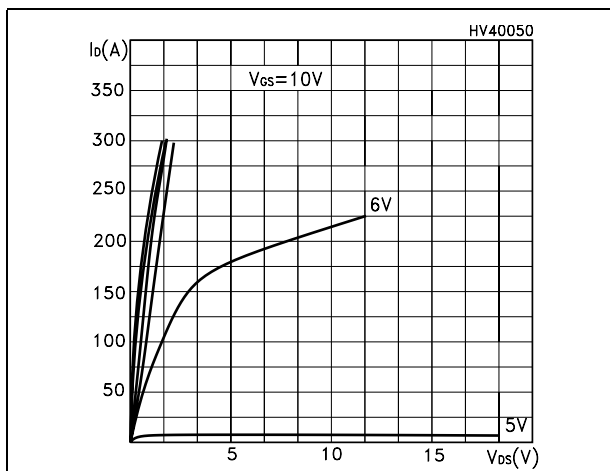

Figure 7. Transfer characteristics

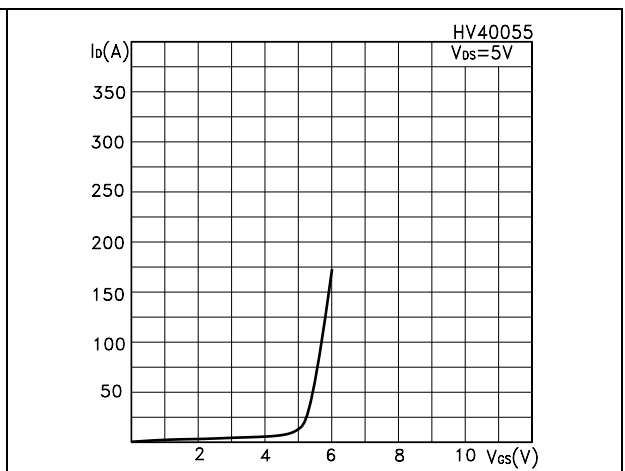

Figure 8. Normalized  $BV_{DSS}$  vs temperature      Figure 9. Static drain-source on resistance

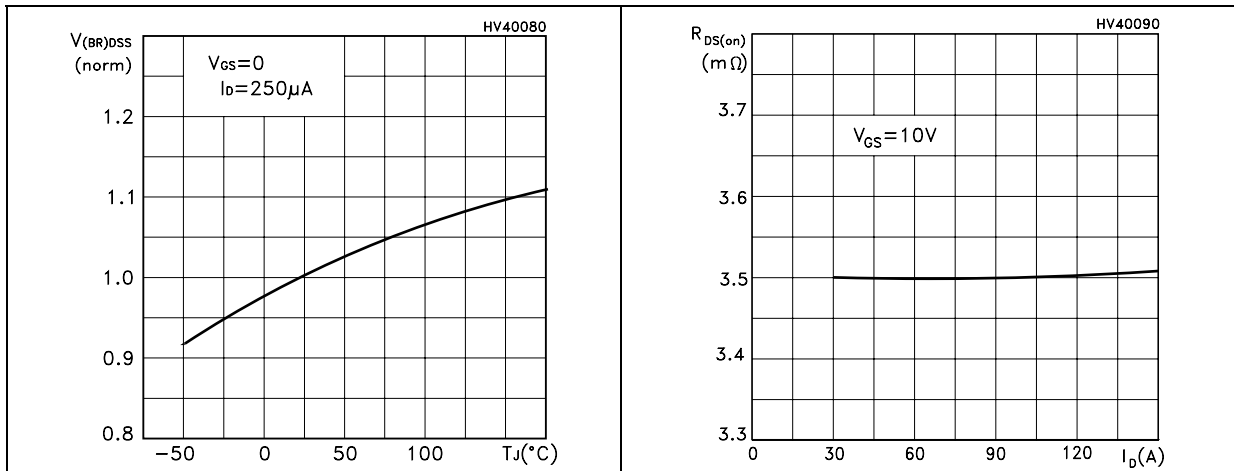

Figure 10. Gate charge vs gate-source voltage      Figure 11. Capacitance variations

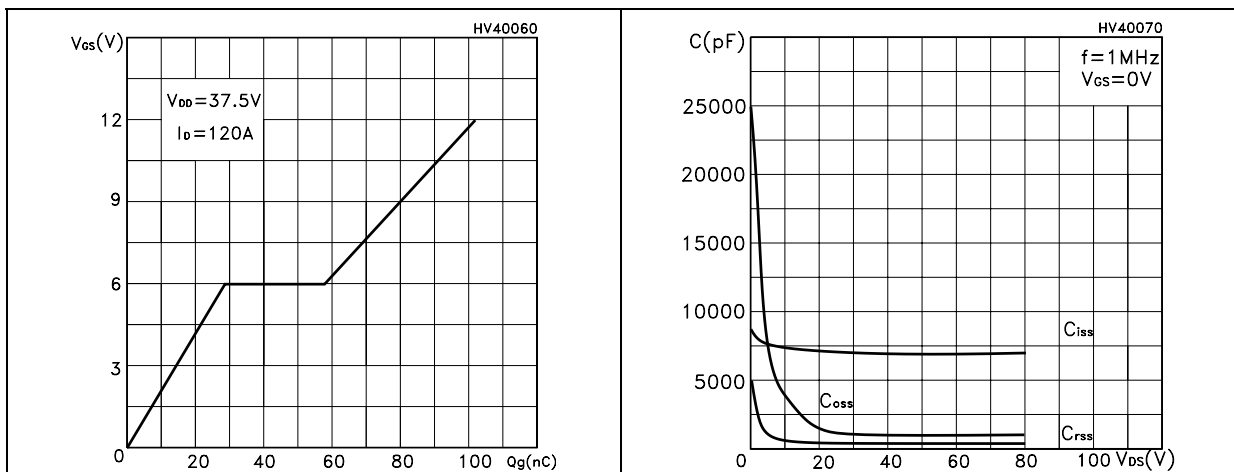

Figure 12. Normalized gate threshold voltage vs temperature      Figure 13. Normalized on resistance vs temperature

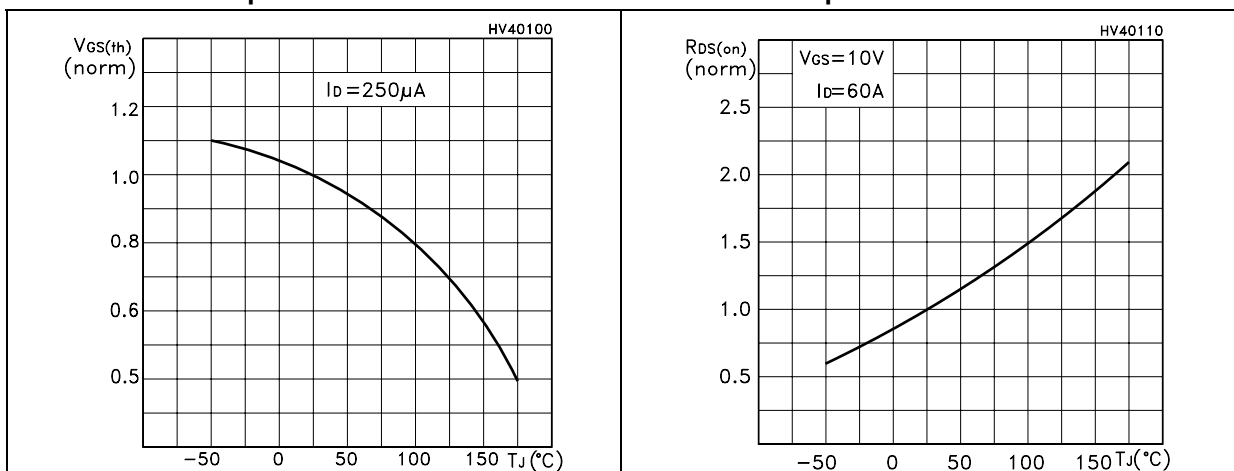
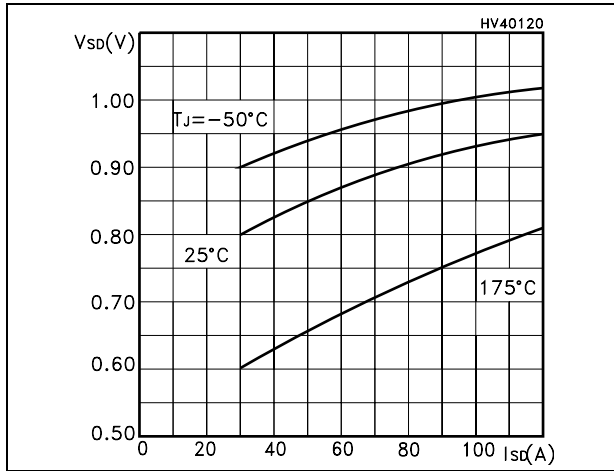

Figure 14. Source-drain diode forward characteristics



### 3 Test circuit

Figure 15. Switching times test circuit for resistive load

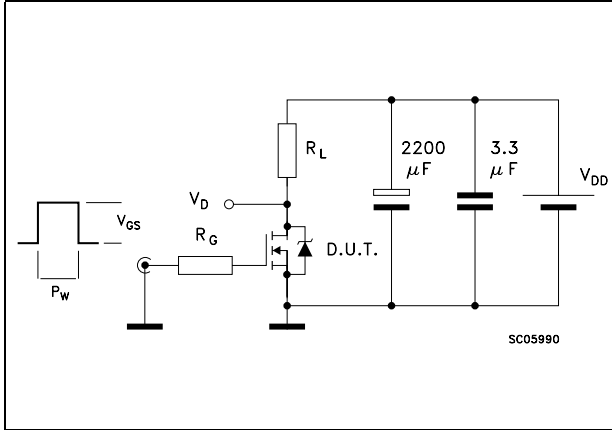

Figure 16. Gate charge test circuit

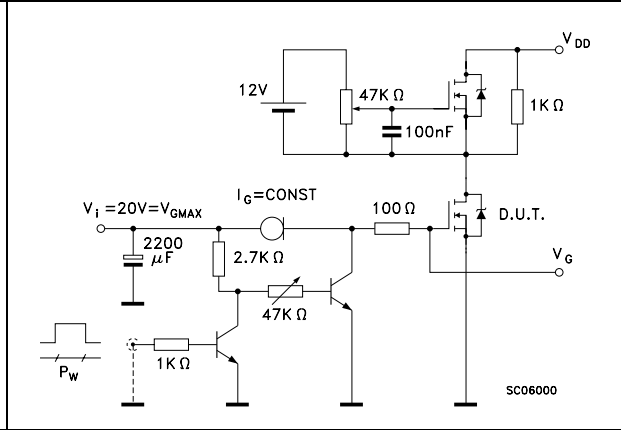

Figure 17. Test circuit for inductive load switching and diode recovery times

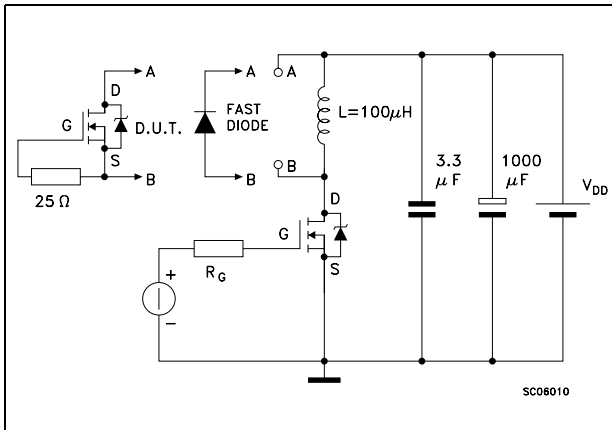

Figure 18. Unclamped inductive load test circuit

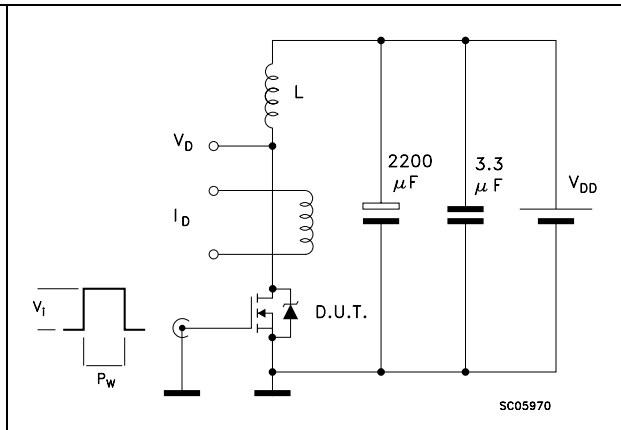

Figure 19. Unclamped inductive waveform

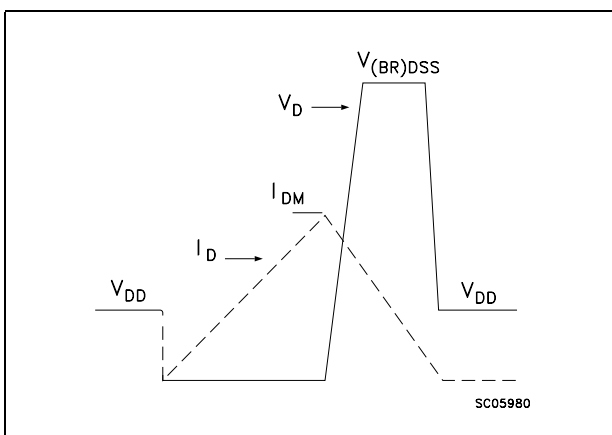
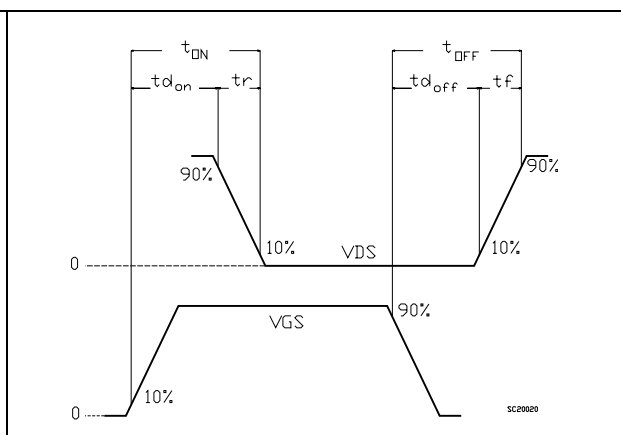

Figure 20. Switching time waveform



## 4 Package mechanical data

In order to meet environmental requirements, ST offers these devices in ECOPACK® packages. These packages have a Lead-free second level interconnect. The category of second level interconnect is marked on the package and on the inner box label, in compliance with JEDEC Standard JESD97. The maximum ratings related to soldering conditions are also marked on the inner box label. ECOPACK is an ST trademark. ECOPACK specifications are available at: [www.st.com](http://www.st.com)

TO-220 mechanical data

Dim	mm			inch		
	Min	Typ	Max	Min	Typ	Max
A	4.40		4.60	0.173		0.181
b	0.61		0.88	0.024		0.034
b1	1.14		1.70	0.044		0.066
c	0.49		0.70	0.019		0.027
D	15.25		15.75	0.6		0.62
D1		1.27			0.050	
E	10		10.40	0.393		0.409
e	2.40		2.70	0.094		0.106
e1	4.95		5.15	0.194		0.202
F	1.23		1.32	0.048		0.051
H1	6.20		6.60	0.244		0.256
J1	2.40		2.72	0.094		0.107
L	13		14	0.511		0.551
L1	3.50		3.93	0.137		0.154
L20		16.40			0.645	
L30		28.90			1.137	
∅P	3.75		3.85	0.147		0.151
Q	2.65		2.95	0.104		0.116

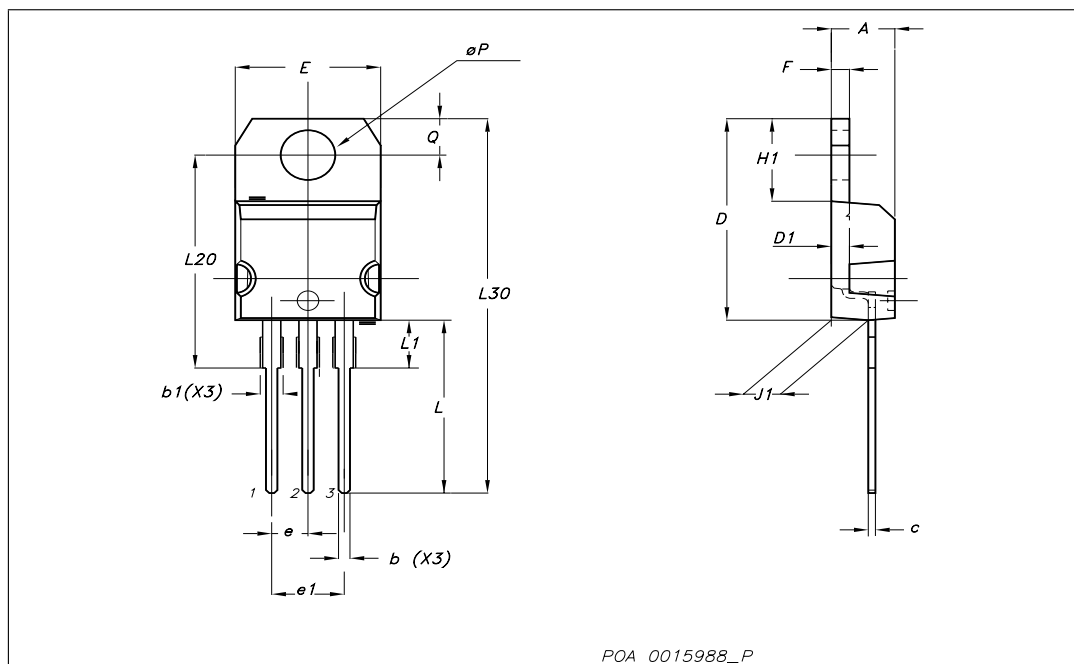

**TO-247 MECHANICAL DATA**

DIM.	mm.			inch		
	MIN.	TYP.	MAX.	MIN.	TYP.	MAX.
A	4.85		5.15	0.19		0.20
A1	2.20		2.60	0.086		0.102
b	1.0		1.40	0.039		0.055
b1	2.0		2.40	0.079		0.094
b2	3.0		3.40	0.118		0.134
c	0.40		0.80	0.015		0.03
D	19.85		20.15	0.781		0.793
E	15.45		15.75	0.608		0.620
e		5.45			0.214	
L	14.20		14.80	0.560		0.582
L1	3.70		4.30	0.14		0.17
L2		18.50			0.728	
øP	3.55		3.65	0.140		0.143
øR	4.50		5.50	0.177		0.216
S		5.50			0.216	

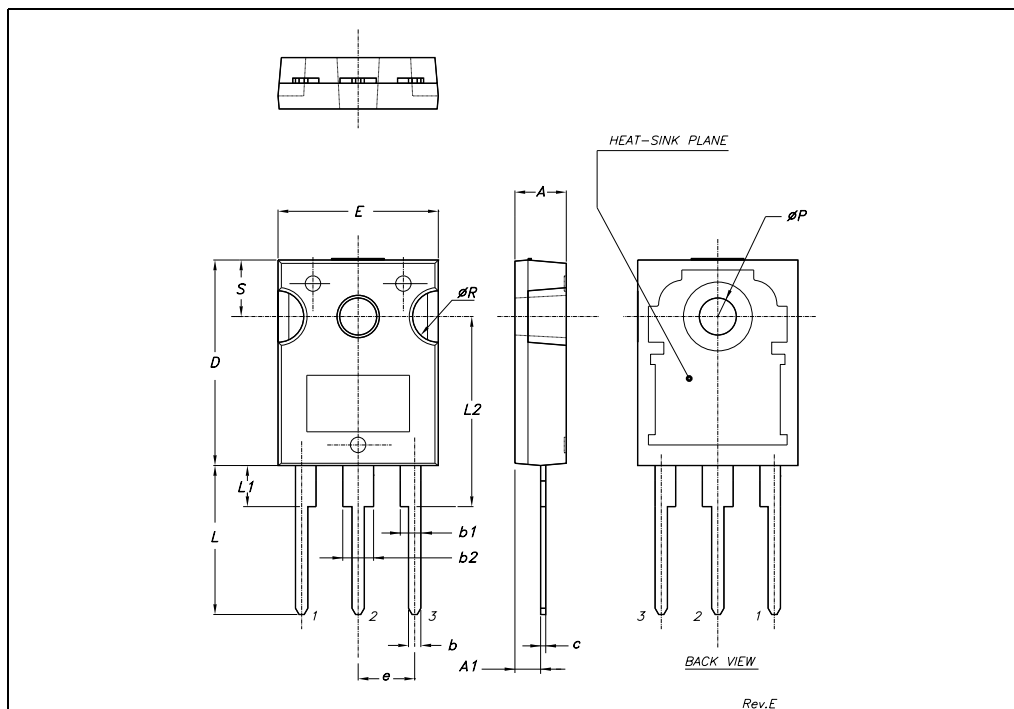

D<sup>2</sup>PAK mechanical data

Dim	mm			inch		
	Min	Typ	Max	Min	Typ	Max
A	4.4		4.6	0.173		0.181
A1	2.49		2.69	0.098		0.106
A2	0.03		0.23	0.001		0.009
B	0.7		0.93	0.027		0.036
B2	1.14		1.7	0.044		0.067
C	0.45		0.6	0.017		0.023
C2	1.23		1.36	0.048		0.053
D	8.95		9.35	0.352		0.368
D1		8			0.315	
E	10		10.4	0.393		0.409
E1		8.5			0.334	
G	4.88		5.28	0.192		0.208
L	15		15.85	0.590		0.625
L2	1.27		1.4	0.50		0.55
L3	1.4		1.75	0.055		0.68
M	2.4		3.2	0.094		0.126
R		0.4			0.015	
V2	0°		4°			

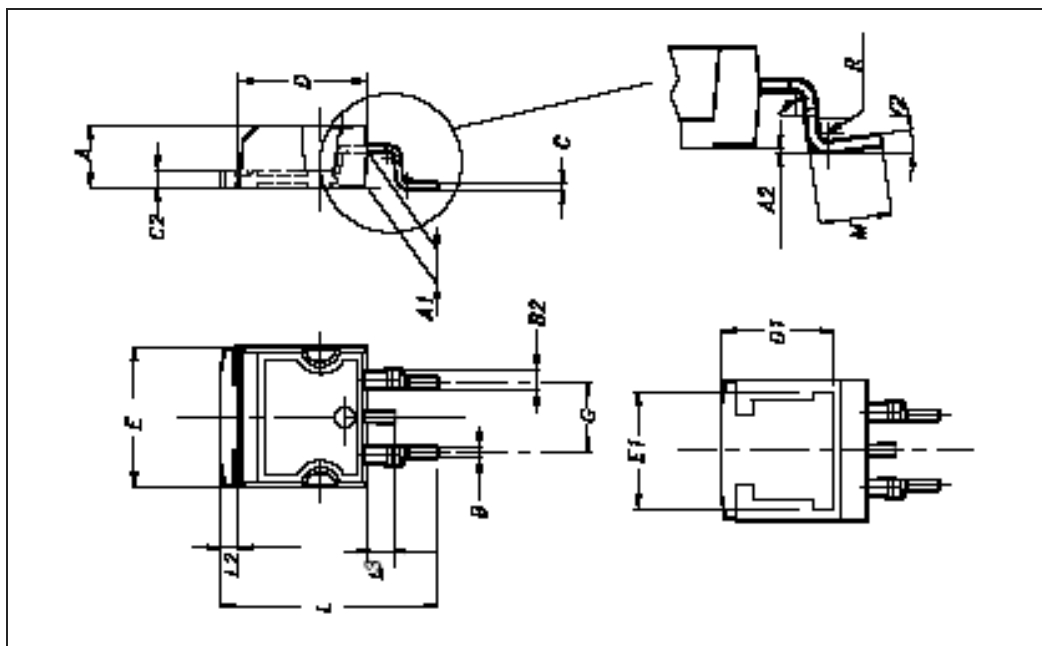

# 5 Packaging mechanical data

## D<sup>2</sup>PAK FOOTPRINT

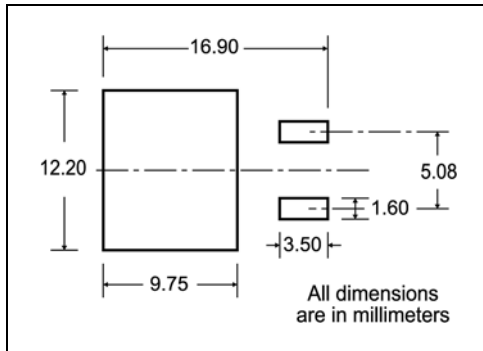

## TAPE AND REEL SHIPMENT

**TAPE MECHANICAL DATA**

DIM.	mm		inch	
	MIN.	MAX.	MIN.	MAX.
A0	10.5	10.7	0.413	0.421
B0	15.7	15.9	0.618	0.626
D	1.5	1.6	0.059	0.063
D1	1.59	1.61	0.062	0.063
E	1.65	1.85	0.065	0.073
F	11.4	11.6	0.449	0.456
K0	4.8	5.0	0.189	0.197
P0	3.9	4.1	0.153	0.161
P1	11.9	12.1	0.468	0.476
P2	1.9	2.1	0.075	0.082
R	50		1.574	
T	0.25	0.35	0.0098	0.0137
W	23.7	24.3	0.933	0.956

**REEL MECHANICAL DATA**

DIM.	mm		inch	
	MIN.	MAX.	MIN.	MAX.
A		330		12.992
B	1.5		0.059	
C	12.8	13.2	0.504	0.520
D	20.2		0.795	
G	24.4	26.4	0.960	1.039
N	100		3.937	
T		30.4		1.197

BASE QTY	BULK QTY
1000	1000

\* on sales type

## 6 Revision history

Table 8. Document revision history

Date	Revision	Changes
07-Feb-2007	1	First release
02-Oct-2007	2	New section has been added: <a href="#">Electrical characteristics (curves)</a>

**Please Read Carefully:**

Information in this document is provided solely in connection with ST products. STMicroelectronics NV and its subsidiaries ("ST") reserve the right to make changes, corrections, modifications or improvements, to this document, and the products and services described herein at any time, without notice.

All ST products are sold pursuant to ST's terms and conditions of sale.

Purchasers are solely responsible for the choice, selection and use of the ST products and services described herein, and ST assumes no liability whatsoever relating to the choice, selection or use of the ST products and services described herein.

No license, express or implied, by estoppel or otherwise, to any intellectual property rights is granted under this document. If any part of this document refers to any third party products or services it shall not be deemed a license grant by ST for the use of such third party products or services, or any intellectual property contained therein or considered as a warranty covering the use in any manner whatsoever of such third party products or services or any intellectual property contained therein.

**UNLESS OTHERWISE SET FORTH IN ST'S TERMS AND CONDITIONS OF SALE ST DISCLAIMS ANY EXPRESS OR IMPLIED WARRANTY WITH RESPECT TO THE USE AND/OR SALE OF ST PRODUCTS INCLUDING WITHOUT LIMITATION IMPLIED WARRANTIES OF MERCHANTABILITY, FITNESS FOR A PARTICULAR PURPOSE (AND THEIR EQUIVALENTS UNDER THE LAWS OF ANY JURISDICTION), OR INFRINGEMENT OF ANY PATENT, COPYRIGHT OR OTHER INTELLECTUAL PROPERTY RIGHT.**

**UNLESS EXPRESSLY APPROVED IN WRITING BY AN AUTHORIZED ST REPRESENTATIVE, ST PRODUCTS ARE NOT RECOMMENDED, AUTHORIZED OR WARRANTED FOR USE IN MILITARY, AIR CRAFT, SPACE, LIFE SAVING, OR LIFE SUSTAINING APPLICATIONS, NOR IN PRODUCTS OR SYSTEMS WHERE FAILURE OR MALFUNCTION MAY RESULT IN PERSONAL INJURY, DEATH, OR SEVERE PROPERTY OR ENVIRONMENTAL DAMAGE. ST PRODUCTS WHICH ARE NOT SPECIFIED AS "AUTOMOTIVE GRADE" MAY ONLY BE USED IN AUTOMOTIVE APPLICATIONS AT USER'S OWN RISK.**

Resale of ST products with provisions different from the statements and/or technical features set forth in this document shall immediately void any warranty granted by ST for the ST product or service described herein and shall not create or extend in any manner whatsoever, any liability of ST.

ST and the ST logo are trademarks or registered trademarks of ST in various countries.

Information in this document supersedes and replaces all information previously supplied.

The ST logo is a registered trademark of STMicroelectronics. All other names are the property of their respective owners.

© 2007 STMicroelectronics - All rights reserved

STMicroelectronics group of companies

Australia - Belgium - Brazil - Canada - China - Czech Republic - Finland - France - Germany - Hong Kong - India - Israel - Italy - Japan - Malaysia - Malta - Morocco - Singapore - Spain - Sweden - Switzerland - United Kingdom - United States of America

[www.st.com](http://www.st.com)