

N-channel 80 V, 0.0017 Ω typ., 180 A, STripFET™ VII DeepGATE Power MOSFET in H²PAK-2, H²PAK-6 and TO-220 packages

Datasheet – production data

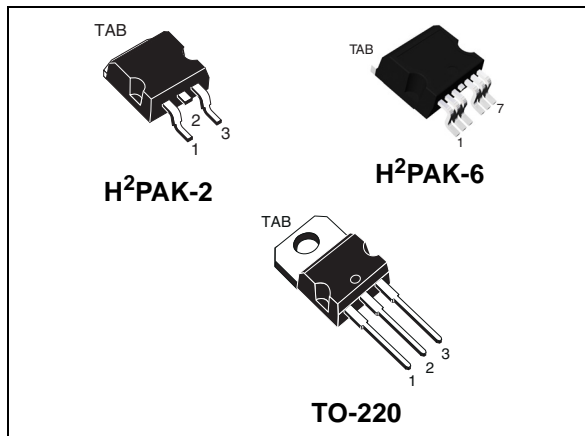
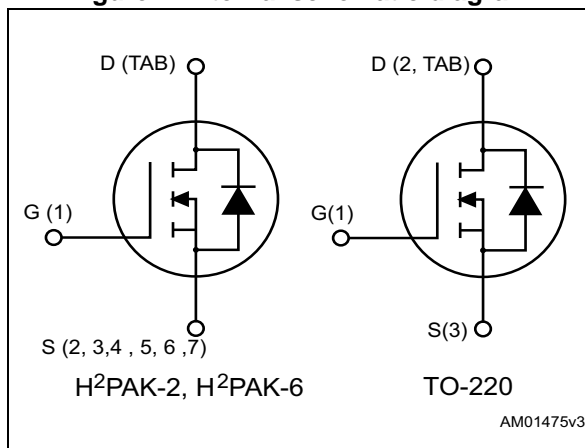

Figure 1. Internal schematic diagram



Features

Order codes	V _{DS}	R _{DS(on)} max	I _D
STH270N8F7-2	80 V	0.0021 Ω	180 A
STH270N8F7-6			
STP270N8F7		0.0025 Ω	

- Ultra low on-resistance
- 100% avalanche tested

Applications

- Switching applications

Description

These devices are N-channel Power MOSFETs developed using the 7th generation of STripFET™ DeepGATE™ technology, with a new gate structure. The resulting Power MOSFET exhibits the lowest R_{DS(on)} in all packages.

Table 1. Device summary

Order codes	Marking	Package	Packaging
STH270N8F7-2	270N8F7	H ² PAK-2	Tape and reel
STH270N8F7-6		H ² PAK-6	
STP270N8F7		TO-220	Tube

Contents

1	Electrical ratings	3
2	Electrical characteristics	4
3	Electrical characteristics (curves)	6
4	Test circuits	9
5	Package mechanical data	10
6	Packaging information	18
7	Revision history	20

1 Electrical ratings

Table 2. Absolute maximum ratings

Symbol	Parameter	Value	Unit
V_{DS}	Drain-source voltage	80	V
V_{GS}	Gate-source voltage	± 20	V
$I_D^{(1)}$	Drain current (continuous)	180	A
$I_D^{(1)}$	Drain current (continuous) at $T_C = 100\text{ }^\circ\text{C}$	180	A
$I_{DM}^{(2)}$	Drain current (pulsed)	720	A
$P_{TOT}^{(3)}$	Total dissipation at $T_C = 25\text{ }^\circ\text{C}$	315	W
$E_{AS}^{(4)}$	Single pulse avalanche energy	1.16	J
T_J	Operating junction temperature	-55 to 175	$^\circ\text{C}$
T_{stg}	Storage temperature		$^\circ\text{C}$

1. Limited by package
2. Pulse width limited by safe operating area
3. This value is rated according to R_{thj-c}
4. Starting $T_j = 25\text{ }^\circ\text{C}$, $I_d = 65\text{ A}$, $V_{dd} = 50\text{ V}$

Table 3. Thermal resistance

Symbol	Parameter	Value		Unit
		H ² PAK-2, H ² PAK-6	TO-220	
$R_{thj-case}$	Thermal resistance junction-case	0.48		$^\circ\text{C/W}$
$R_{thj-pcb}^{(1)}$	Thermal resistance junction-pcb	35		$^\circ\text{C/W}$
$R_{thj-amb}$	Thermal resistance junction-ambient max		62.5	$^\circ\text{C/W}$

1. When mounted on FR-4 board of 1 inch², 2oz Cu

2 Electrical characteristics

($T_{CASE}=25\text{ °C}$ unless otherwise specified)

Table 4. On/off states

Symbol	Parameter	Test conditions	Min.	Typ.	Max.	Unit
$V_{(BR)DSS}$	Drain-source breakdown voltage ($V_{GS}=0$)	$I_D = 250\ \mu\text{A}$	80			V
I_{DSS}	Zero gate voltage drain current ($V_{GS}=0$)	$V_{DS} = 80\text{ V}$ $V_{DS} = 80\text{ V}; T_C=125\text{ °C}$			10 100	μA μA
I_{GSS}	Gate body leakage current ($V_{DS}=0$)	$V_{GS} = +20\text{ V}$			100	nA
$V_{GS(th)}$	Gate threshold voltage	$V_{DS}=V_{GS}, I_D = 250\ \mu\text{A}$	2		4	V
$R_{DS(on)}$	Static drain-source on-resistance	For H ² PAK-2, H ² PAK-6: $V_{GS} = 10\text{ V}, I_D = 90\text{ A}$		0.0017	0.0021	Ω
		For TO-220: $V_{GS} = 10\text{ V}, I_D = 90\text{ A}$		0.0021	0.0025	

Table 5. Dynamic

Symbol	Parameter	Test conditions	Min.	Typ.	Max.	Unit
C_{iss}	Input capacitance	$V_{DS}=50\text{ V}, f=1\text{ MHz},$ $V_{GS}=0$	-	13600	-	pF
C_{oss}	Output capacitance		-	2050	-	pF
C_{rss}	Reverse transfer capacitance		-	70	-	pF
Q_g	Total gate charge	$V_{DD}=40\text{ V}, I_D = 180\text{ A}$ $V_{GS}=10\text{ V}$ <i>Figure 19</i>	-	193	-	nC
Q_{gs}	Gate-source charge		-	96	-	nC
Q_{gd}	Gate-drain charge		-	46	-	nC

Table 6. Switching times

Symbol	Parameter	Test conditions	Min.	Typ.	Max.	Unit
$t_{d(on)}$	Turn-on delay time	$V_{DD}=40\text{ V}, I_D = 90\text{ A},$ $R_G=4.7\ \Omega, V_{GS}=10\text{ V}$ <i>Figure 18</i>	-	56	-	ns
t_r	Rise time		-	180	-	ns
$t_{d(off)}$	Turn-off delay time		-	98	-	ns
t_f	Fall time		-	42	-	ns

Table 7. Source drain diode

Symbol	Parameter	Test conditions	Min	Typ.	Max	Unit
I_{SD}	Source-drain current		-		180	A
$I_{SDM}^{(1)}$	Source-drain current (pulsed)		-		720	A
$V_{SD}^{(2)}$	Forward on voltage	$I_{SD} = 90 \text{ A}, V_{GS} = 0$	-		1.2	V
t_{rr}	Reverse recovery time	$I_{SD} = 180 \text{ A},$ $di/dt = 100 \text{ A}/\mu\text{s},$ $V_{DD} = 64 \text{ V}, T_j = 150 \text{ }^\circ\text{C}$	-	78		ns
Q_{rr}	Reverse recovery charge		-	182		nC
I_{RRM}	Reverse recovery current		-	4.7		A

1. Pulse width limited by safe operating area
2. Pulsed: pulse duration=300 μ s, duty cycle 1.5%

3 Electrical characteristics (curves)

Figure 2. Safe operating area for H²PAK-2 and H²PAK-6

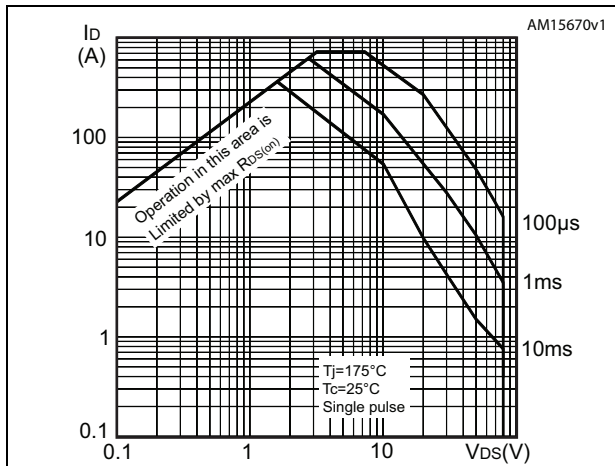

Figure 3. Safe operating area for TO-220

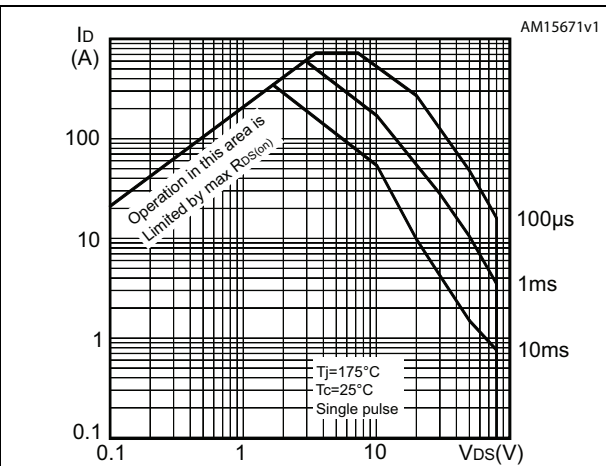

Figure 4. Thermal impedance

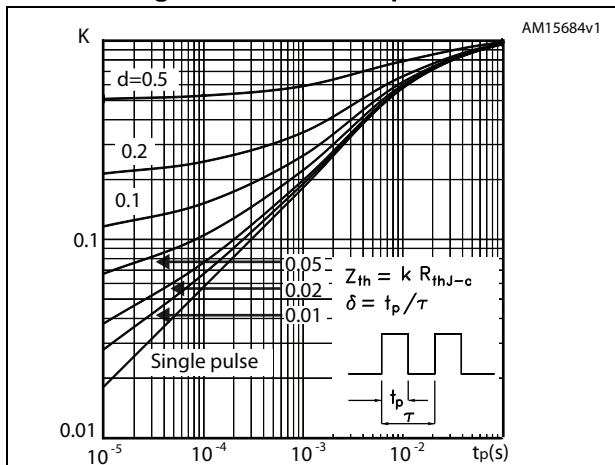

Figure 5. Gate charge vs gate-source voltage

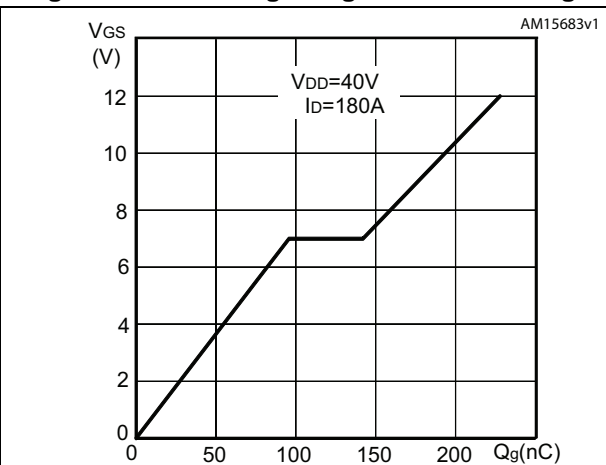

Figure 6. Output characteristics for TO-220

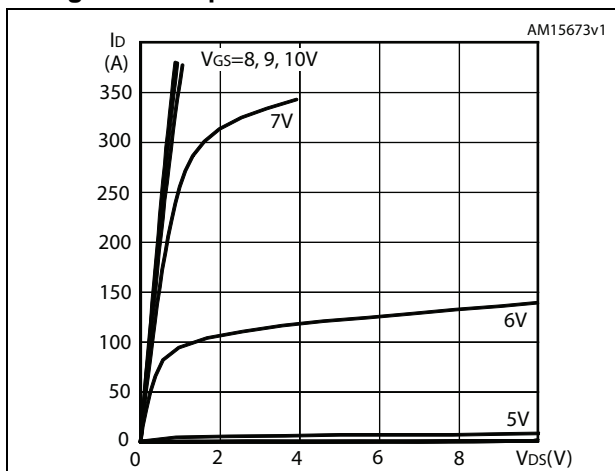

Figure 7. Transfer characteristics for TO-220

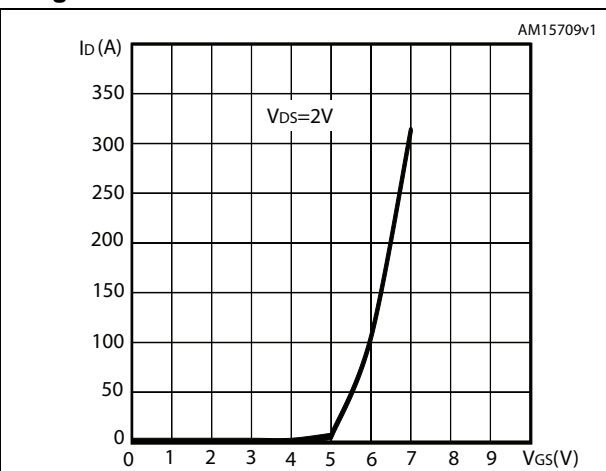

Figure 8. Output characteristics for H²PAK-2 and H²PAK-6

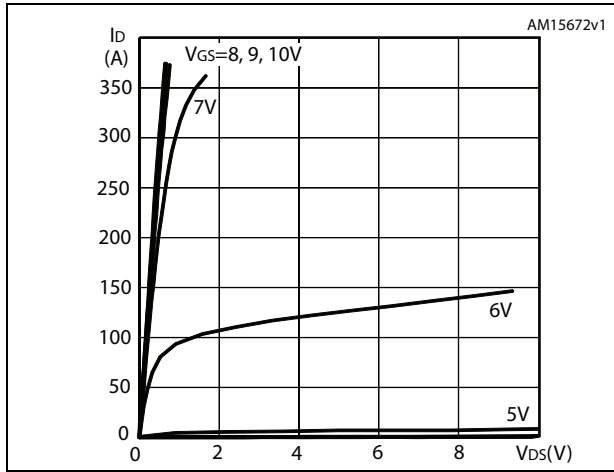

Figure 9. Transfer characteristics for H²PAK-2 and H²PAK-6

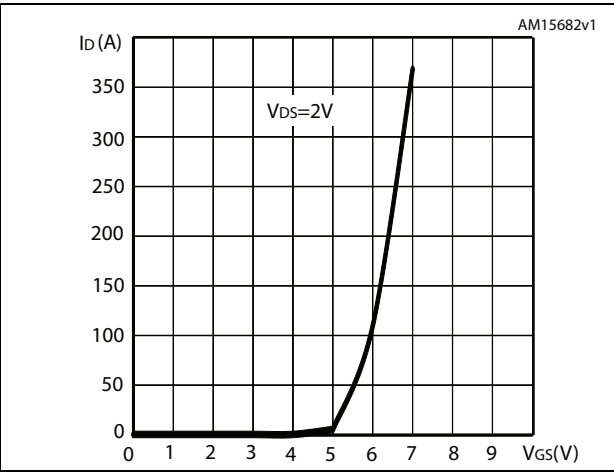

Figure 10. Normalized B_{VDSS} vs temperature

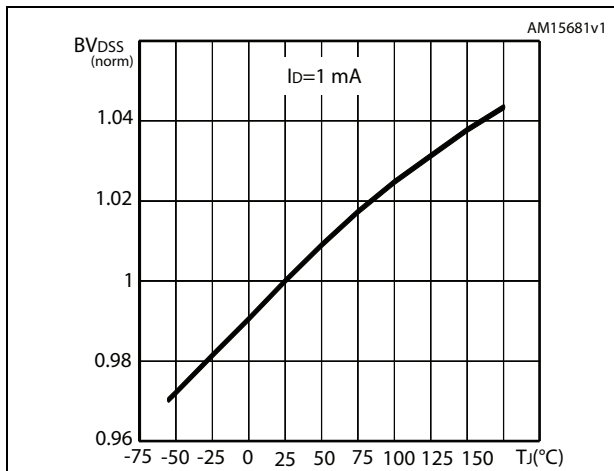

Figure 11. Static drain-source on-resistance for H²PAK-2 and H²PAK-6

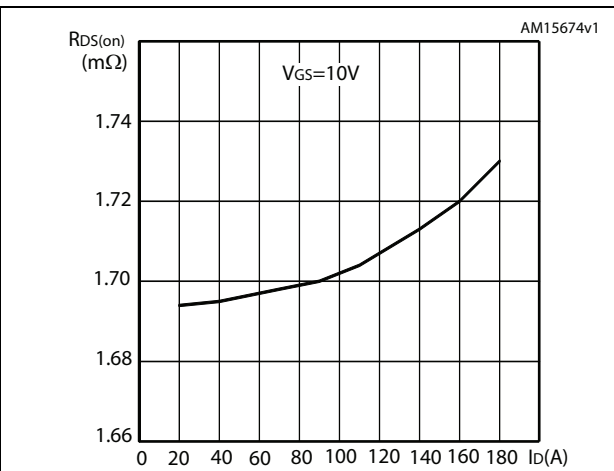

Figure 12. Static drain-source on-resistance for TO-220

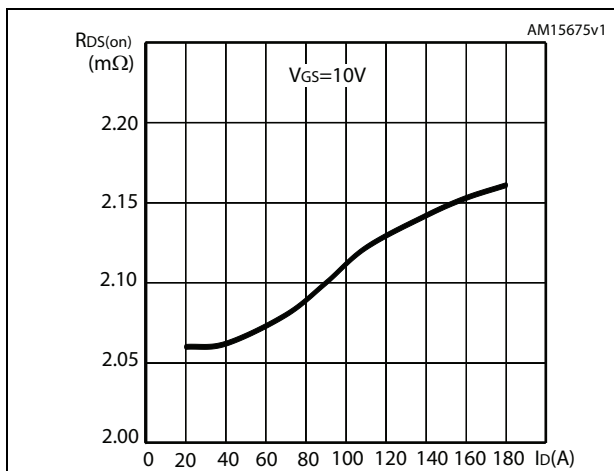

Figure 13. Capacitance variations

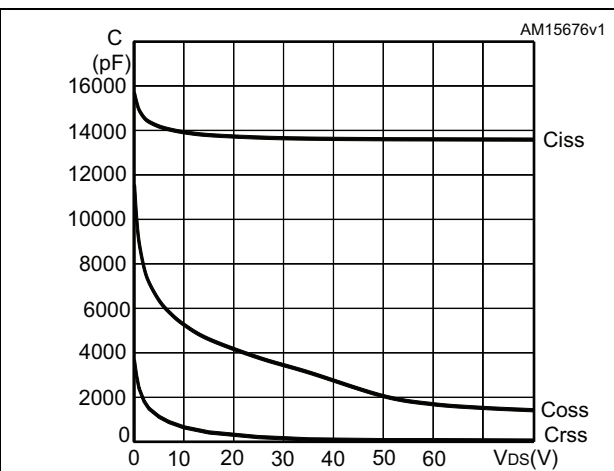

Figure 14. Source-drain diode forward characteristics

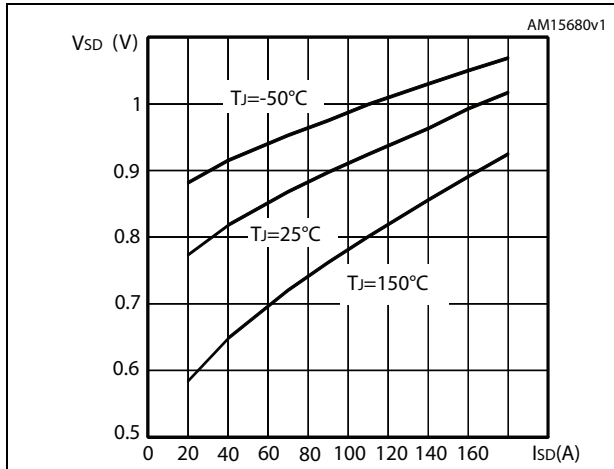

Figure 15. Normalized gate threshold voltage vs temperature

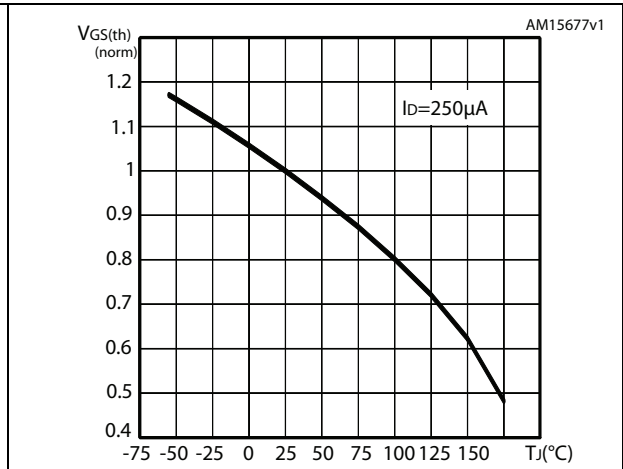

Figure 16. Normalized on-resistance vs temperature for H²PAK-2 and H²PAK-6

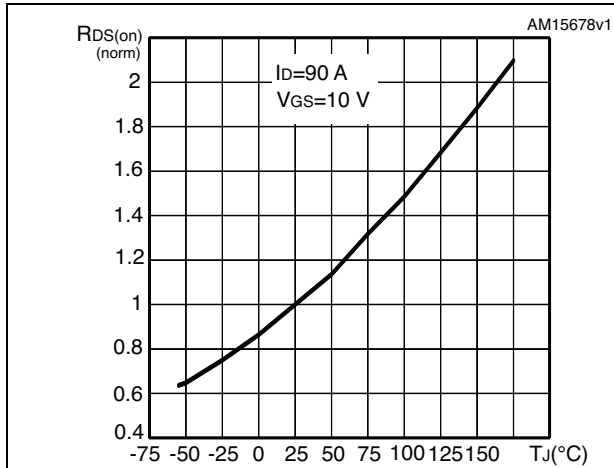
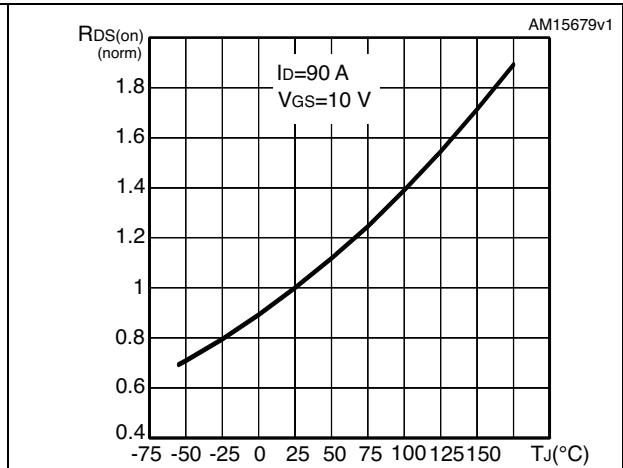

Figure 17. Normalized on-resistance vs temperature for TO-220



4 Test circuits

Figure 18. Switching times test circuit for resistive load

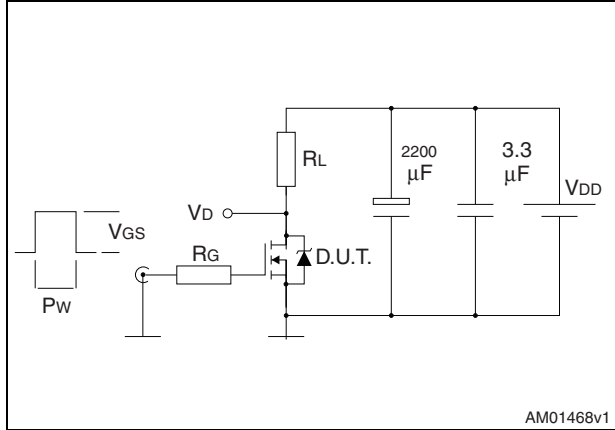

Figure 19. Gate charge test circuit

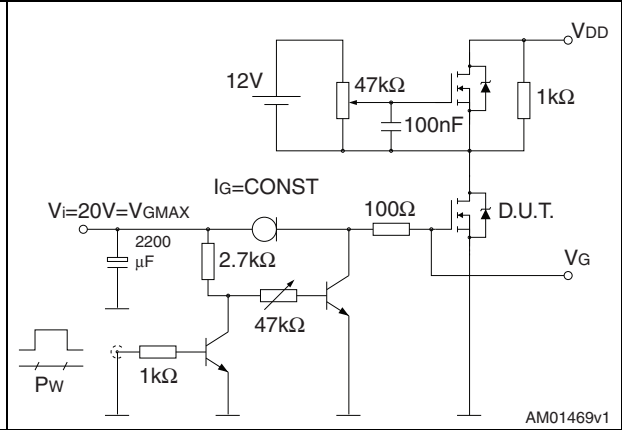

Figure 20. Test circuit for inductive load switching and diode recovery times

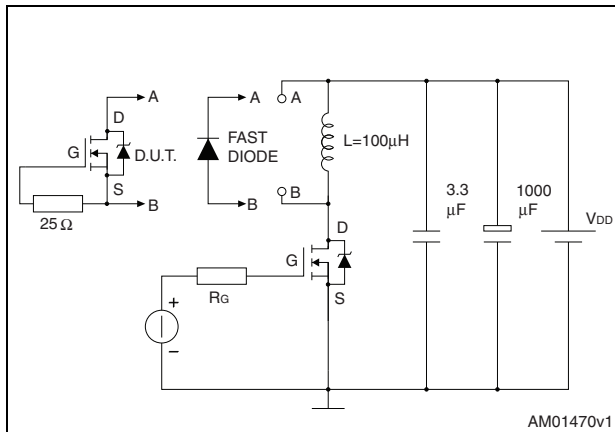

Figure 21. Unclamped inductive load test circuit

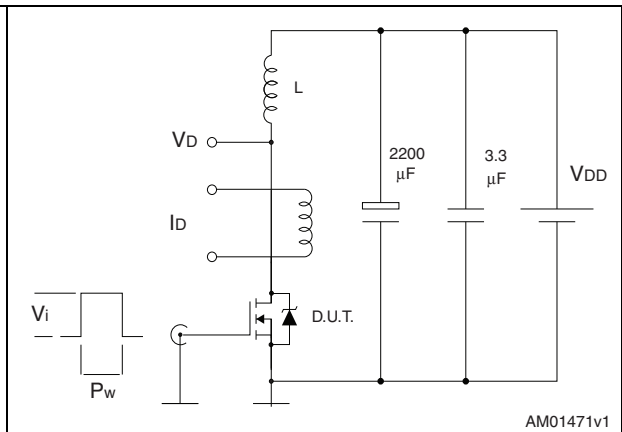

Figure 22. Unclamped inductive waveform

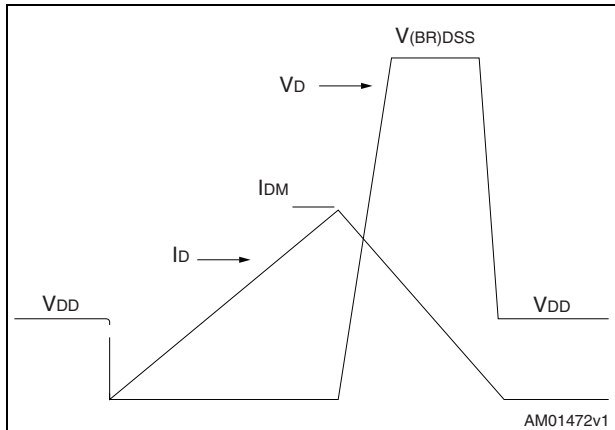
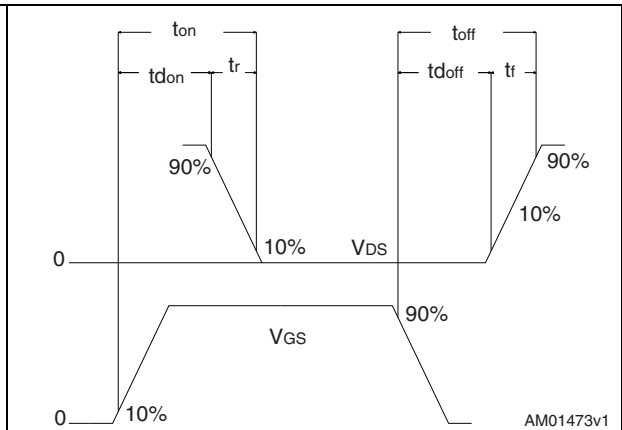

Figure 23. Switching time waveform



5 Package mechanical data

Table 8. H²PAK-2 mechanical data

Dim.	mm		
	Min.	Typ.	Max.
A	4.30		4.80
A1	0.03		0.20
C	1.17		1.37
e	4.98		5.18
E	0.50		0.90
F	0.78		0.85
H	10.00		10.40
H1	7.40		7.80
L	15.30		15.80
L1	1.27		1.40
L2	4.93		5.23
L3	6.85		7.25
L4	1.5		1.7
M	2.6		2.9
R	0.20		0.60
V	0°		8°

Figure 24. H²PAK-2 drawing

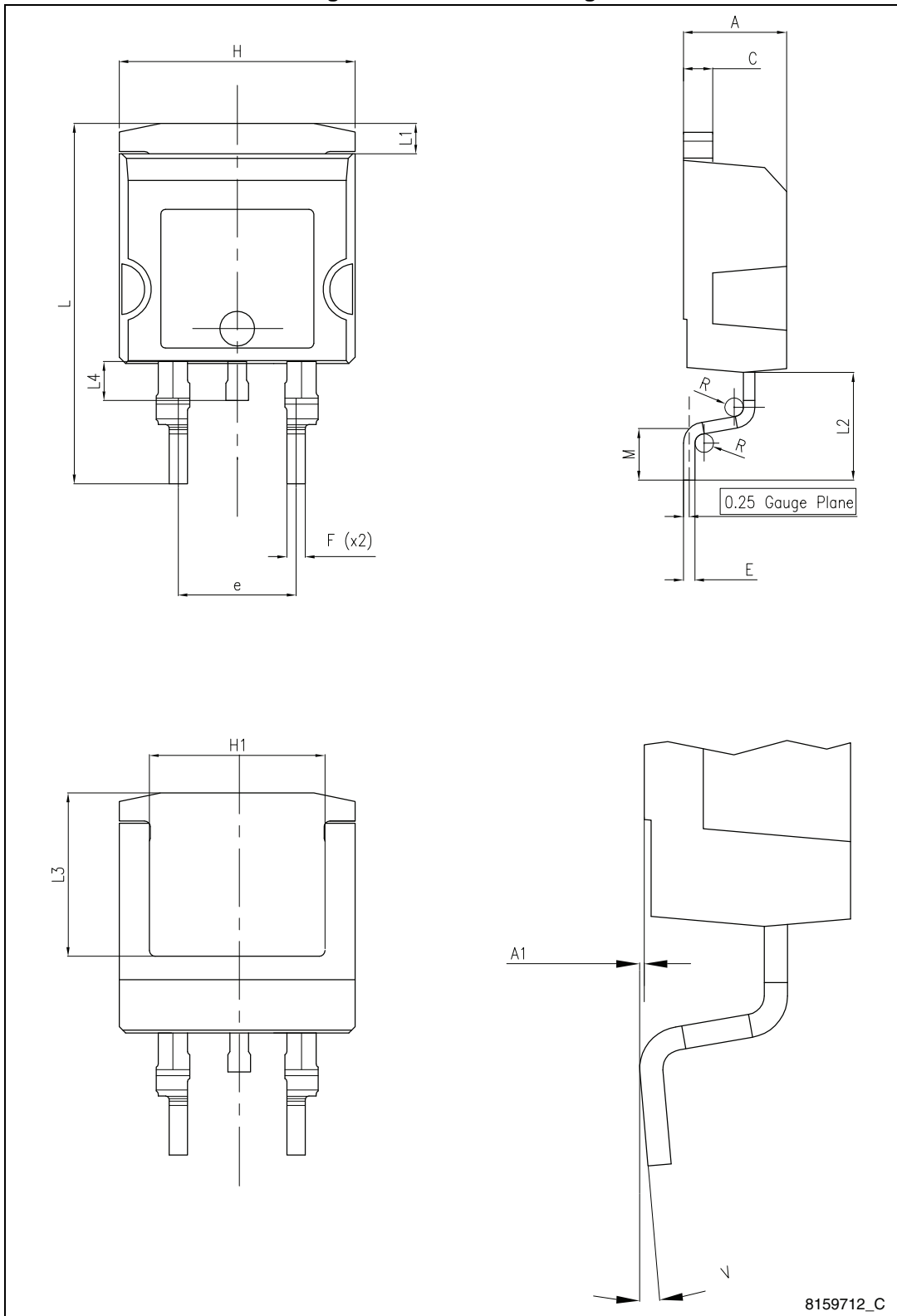
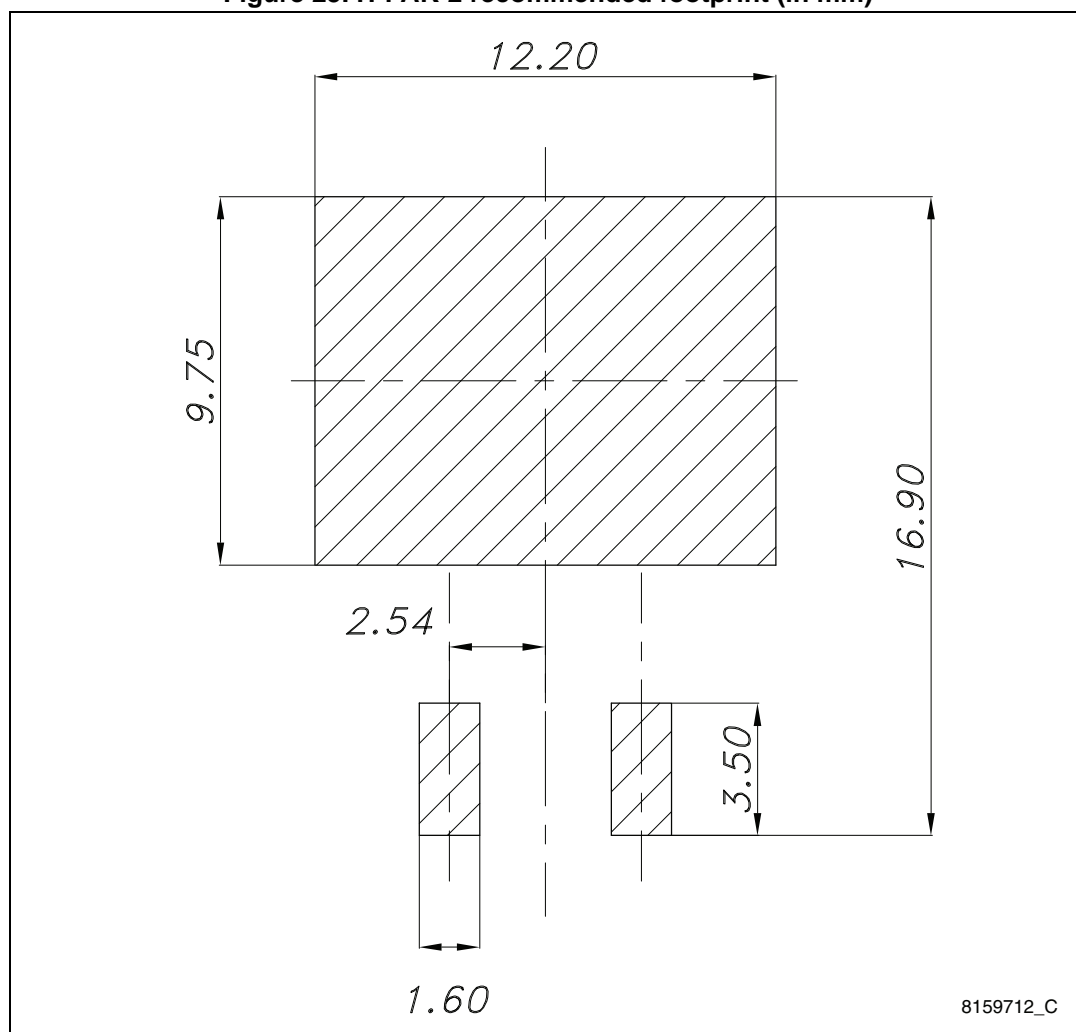

Figure 25. H²PAK-2 recommended footprint (in mm)



8159712_C

Table 9. H²PAK-6 mechanical data

Dim.	mm		
	Min.	Typ.	Max.
A	4.30		4.80
A1	0.03		0.20
C	1.17		1.37
e	2.34		2.74
e1	4.88		5.28
e2	7.42		7.82
E	0.45		0.60
F	0.50		0.70
H	10.00		10.40
H1	7.40		7.80
L	14.75		15.25
L1	1.27		1.40
L2	4.35		4.95
L3	6.85		7.25
L4	1.5		1.75
M	1.90		2.50
R	0.20		0.60
V	0°		8°

Figure 26. H²PAK-6 drawing

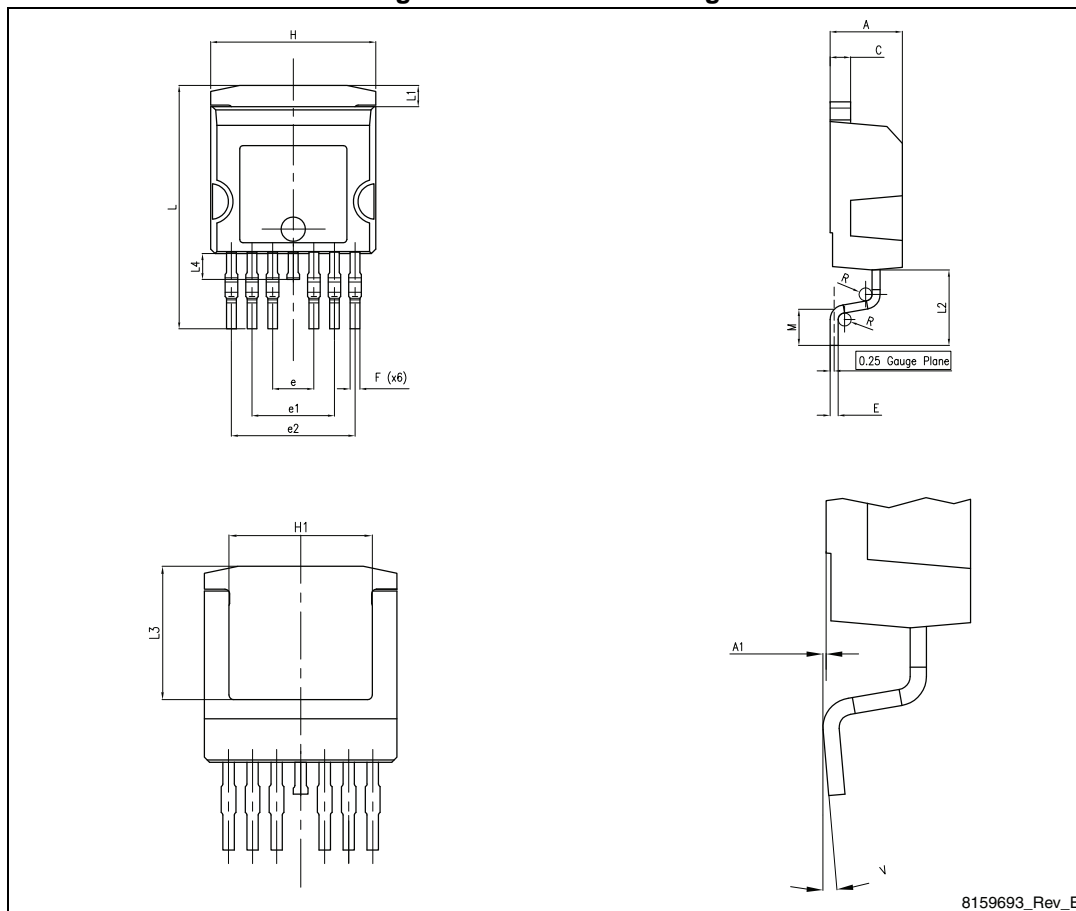

Figure 27. H²PAK-6 recommended footprint (dimensions are in mm)

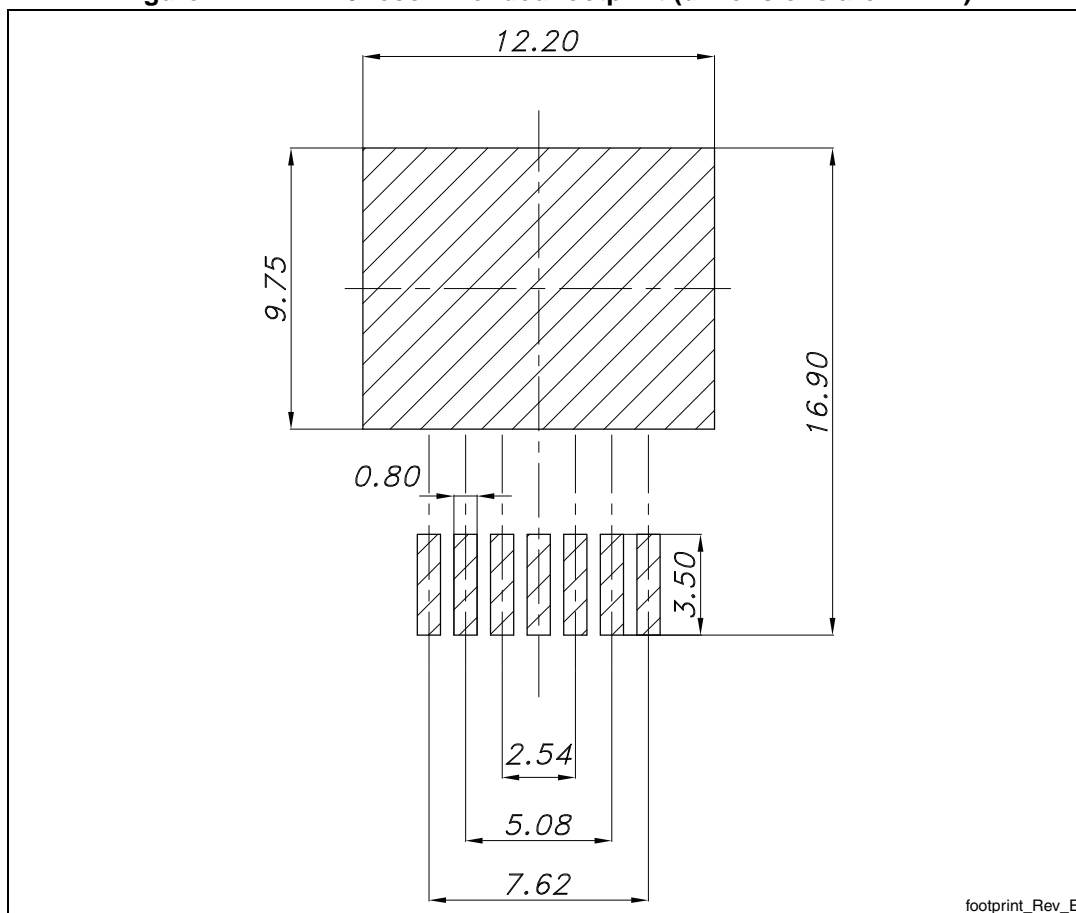
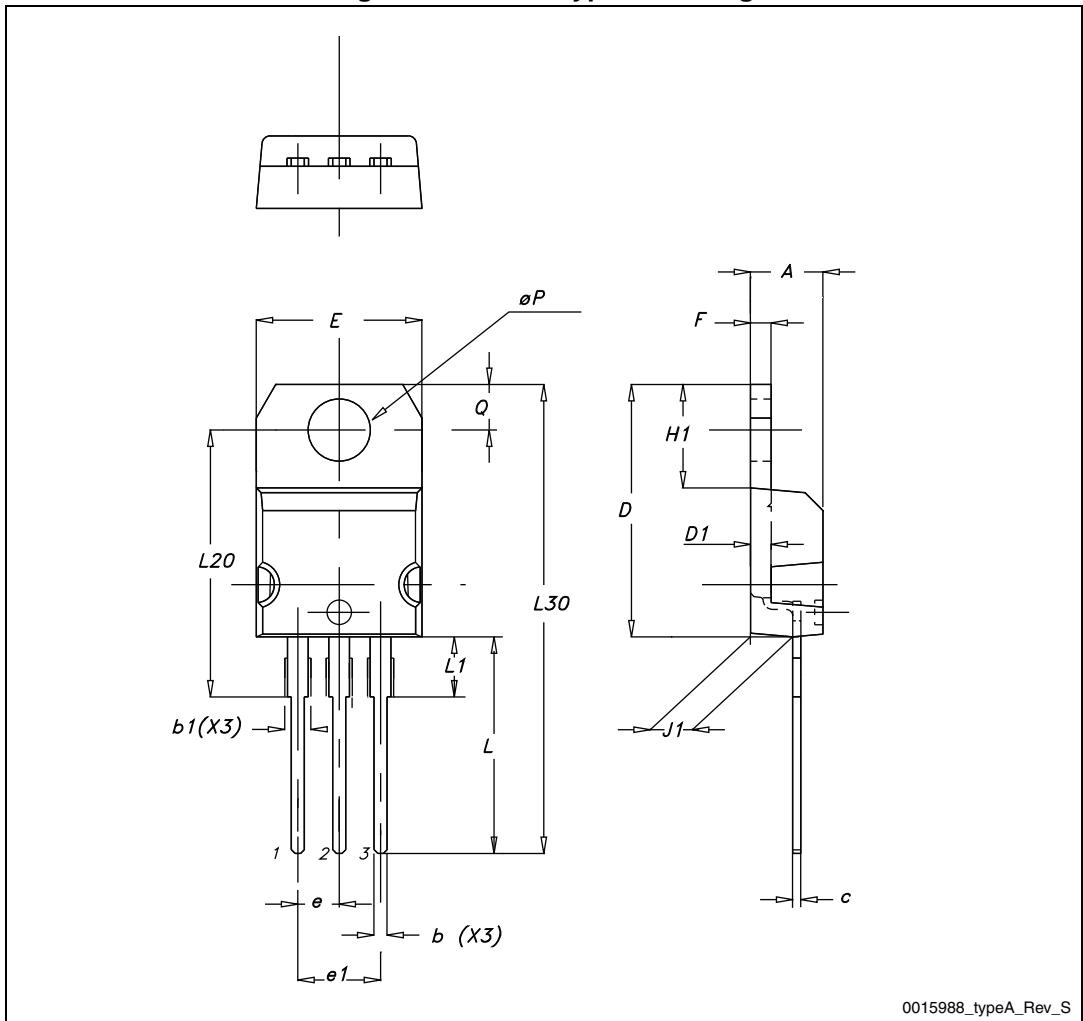

Table 10. TO-220 type A mechanical data

Dim.	mm		
	Min.	Typ.	Max.
A	4.40		4.60
b	0.61		0.88
b1	1.14		1.70
c	0.48		0.70
D	15.25		15.75
D1		1.27	
E	10		10.40
e	2.40		2.70
e1	4.95		5.15
F	1.23		1.32
H1	6.20		6.60
J1	2.40		2.72
L	13		14
L1	3.50		3.93
L20		16.40	
L30		28.90	
ØP	3.75		3.85
Q	2.65		2.95

Figure 28. TO-220 type A drawing



0015988_typeA_Rev_S

6 Packaging information

Table 11. H²PAK-2 and H²PAK-6 tape and reel mechanical data

Tape			Reel		
Dim.	mm		Dim.	mm	
	Min.	Max.		Min.	Max.
A0	10.5	10.7	A		330
B0	15.7	15.9	B	1.5	
D	1.5	1.6	C	12.8	13.2
D1	1.59	1.61	D	20.2	
E	1.65	1.85	G	24.4	26.4
F	11.4	11.6	N	100	
K0	4.8	5.0	T		30.4
P0	3.9	4.1			
P1	11.9	12.1		Base qty	1000
P2	1.9	2.1		Bulk qty	1000
R	50				
T	0.25	0.35			
W	23.7	24.3			

Figure 29. Tape

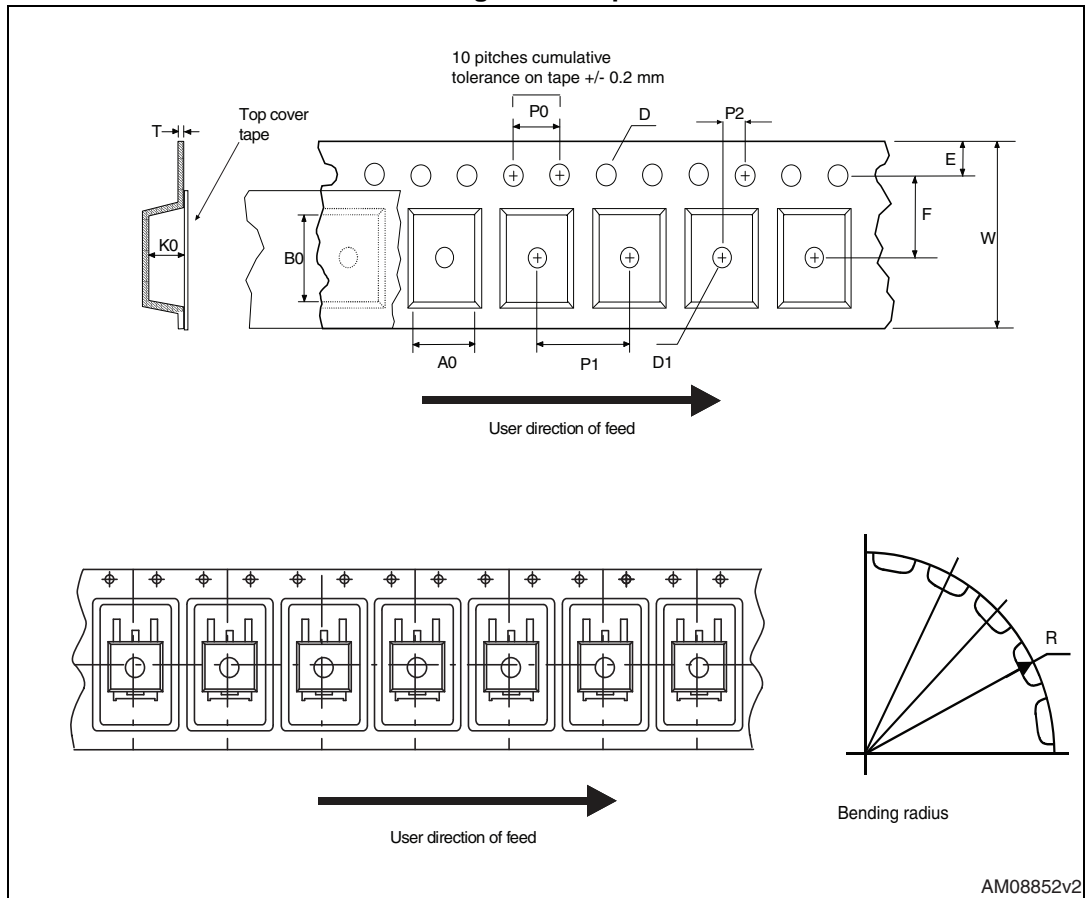
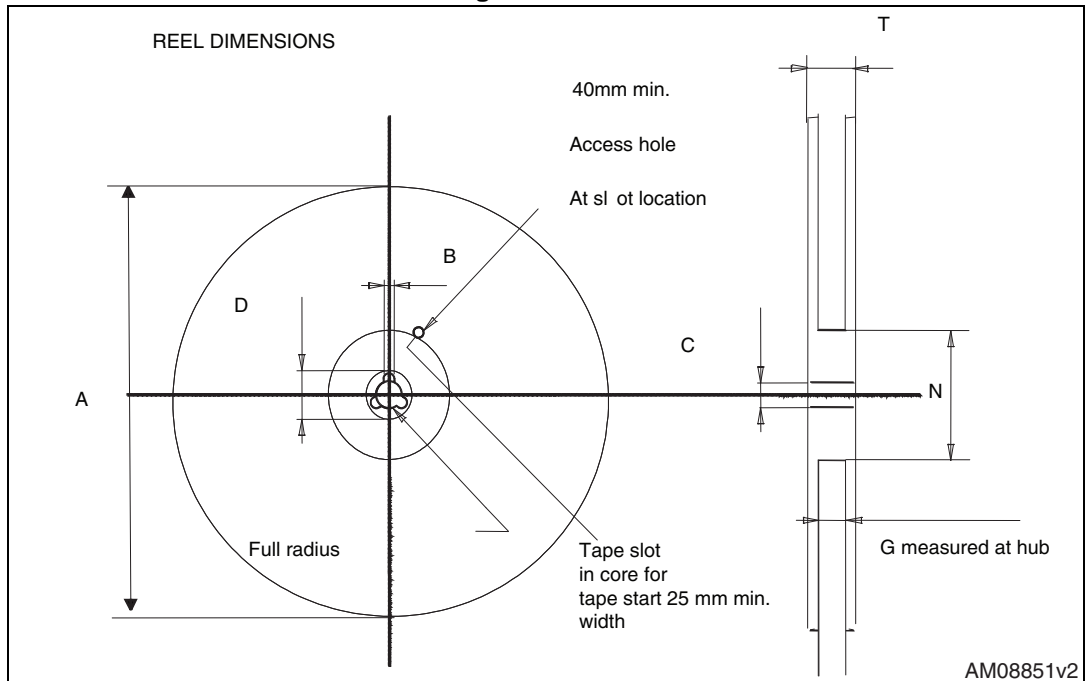

Figure 30. Reel



7 Revision history

Table 12. Document revision history

Date	Revision	Changes
03-Dec-2012	1	First release.
09-Apr-2013	2	<ul style="list-style-type: none">– Modified: $R_{DS(on)}$ max values on Features table, I_{DSS}, I_{GSS} values on Table 4, $R_{DS(on)}$ value for H²PAK-2, the entire typical values on Table 5 and 6, V_{SD} test conditions and max values, T_{RR}, Q_{RR}, I_{RRM} typical values on Table 7– Inserted: Section 3: Electrical characteristics (curves)– Document status promoted to preliminary data to production data– Added: H²PAK-6 package– Minor text changes

Please Read Carefully:

Information in this document is provided solely in connection with ST products. STMicroelectronics NV and its subsidiaries ("ST") reserve the right to make changes, corrections, modifications or improvements, to this document, and the products and services described herein at any time, without notice.

All ST products are sold pursuant to ST's terms and conditions of sale.

Purchasers are solely responsible for the choice, selection and use of the ST products and services described herein, and ST assumes no liability whatsoever relating to the choice, selection or use of the ST products and services described herein.

No license, express or implied, by estoppel or otherwise, to any intellectual property rights is granted under this document. If any part of this document refers to any third party products or services it shall not be deemed a license grant by ST for the use of such third party products or services, or any intellectual property contained therein or considered as a warranty covering the use in any manner whatsoever of such third party products or services or any intellectual property contained therein.

UNLESS OTHERWISE SET FORTH IN ST'S TERMS AND CONDITIONS OF SALE ST DISCLAIMS ANY EXPRESS OR IMPLIED WARRANTY WITH RESPECT TO THE USE AND/OR SALE OF ST PRODUCTS INCLUDING WITHOUT LIMITATION IMPLIED WARRANTIES OF MERCHANTABILITY, FITNESS FOR A PARTICULAR PURPOSE (AND THEIR EQUIVALENTS UNDER THE LAWS OF ANY JURISDICTION), OR INFRINGEMENT OF ANY PATENT, COPYRIGHT OR OTHER INTELLECTUAL PROPERTY RIGHT.

ST PRODUCTS ARE NOT AUTHORIZED FOR USE IN WEAPONS. NOR ARE ST PRODUCTS DESIGNED OR AUTHORIZED FOR USE IN: (A) SAFETY CRITICAL APPLICATIONS SUCH AS LIFE SUPPORTING, ACTIVE IMPLANTED DEVICES OR SYSTEMS WITH PRODUCT FUNCTIONAL SAFETY REQUIREMENTS; (B) AERONAUTIC APPLICATIONS; (C) AUTOMOTIVE APPLICATIONS OR ENVIRONMENTS, AND/OR (D) AEROSPACE APPLICATIONS OR ENVIRONMENTS. WHERE ST PRODUCTS ARE NOT DESIGNED FOR SUCH USE, THE PURCHASER SHALL USE PRODUCTS AT PURCHASER'S SOLE RISK, EVEN IF ST HAS BEEN INFORMED IN WRITING OF SUCH USAGE, UNLESS A PRODUCT IS EXPRESSLY DESIGNATED BY ST AS BEING INTENDED FOR "AUTOMOTIVE, AUTOMOTIVE SAFETY OR MEDICAL" INDUSTRY DOMAINS ACCORDING TO ST PRODUCT DESIGN SPECIFICATIONS. PRODUCTS FORMALLY ESCC, QML OR JAN QUALIFIED ARE DEEMED SUITABLE FOR USE IN AEROSPACE BY THE CORRESPONDING GOVERNMENTAL AGENCY.

Resale of ST products with provisions different from the statements and/or technical features set forth in this document shall immediately void any warranty granted by ST for the ST product or service described herein and shall not create or extend in any manner whatsoever, any liability of ST.

ST and the ST logo are trademarks or registered trademarks of ST in various countries.

Information in this document supersedes and replaces all information previously supplied.

The ST logo is a registered trademark of STMicroelectronics. All other names are the property of their respective owners.

© 2013 STMicroelectronics - All rights reserved

STMicroelectronics group of companies

Australia - Belgium - Brazil - Canada - China - Czech Republic - Finland - France - Germany - Hong Kong - India - Israel - Italy - Japan - Malaysia - Malta - Morocco - Philippines - Singapore - Spain - Sweden - Switzerland - United Kingdom - United States of America

www.st.com

