

Turbo 2 ultrafast high voltage rectifier

Datasheet – production data

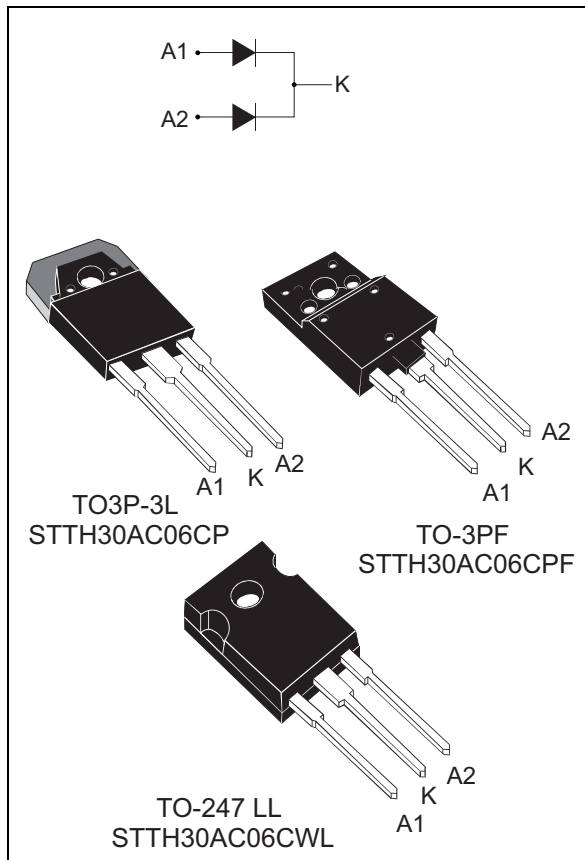

Description

The STTH30AC06C uses ST Turbo 2 600 V technology. It is suited as boost diode specially for use in air conditioning equipment as continuous mode interleaved power factor correction.

Table 1. Device summary

Symbol	Value
$I_{F(AV)}$	2 x 15A
V_{RRM}	600 V
t_{rr} (typ)	40 ns
V_F (typ)	1.15 V
T_j	175 °C

Features

- Ultrafast switching
- Low reverse current
- High thermal resistance
- Reduces switching and conduction losses
- Insulated package TO-3PF:
 - Insulated voltage: 2500 V DC

1 Characteristics

Table 2. Absolute ratings (limiting values per diode at 25 °C, unless otherwise specified)

Symbol	Parameter		Value	Unit
V_{RRM}	Repetitive peak reverse voltage		600	V
$I_{F(RMS)}$	Forward rms current		30	A
$I_{F(AV)}$	average forward current	Per diode	15	A
		Per device	30	
I_{FSM}	Surge non repetitive forward current	$t_p = 10$ ms sinusoidal	140	A
T_{stg}	Storage temperature range		-65 to +175	°C
T_j	Maximum operating junction temperature		175	°C

Table 3. Thermal parameters

Symbol	Parameter		Value	Unit
$R_{th(j-c)}$	Junction to case (TO3P-3L, TO247 LL)	Per diode	1.5	°C/W
		Total	0.85	
$R_{th(c)}$	Coupling (TO3P-3L, TO247 LL)		0.2	
$R_{th(j-c)}$	Junction to case (TO-3PF)	Per diode	3.5	
		Total	2.7	
$R_{th(c)}$	Coupling (TO-3PF)		1.9	

Table 4. Static electrical characteristics (per diode)

Symbol	Parameter	Test conditions		Min.	Typ.	Max.	Unit
$I_R^{(1)}$	Reverse leakage current	$T_j = 25$ °C	$V_R = V_{RRM}$			10	µA
		$T_j = 150$ °C			40	400	
$V_F^{(2)}$	Forward voltage drop	$T_j = 25$ °C	$I_F = 15$ A			1.95	V
		$T_j = 150$ °C			1.15	1.45	
		$T_j = 25$ °C	$I_F = 30$ A			2.25	
		$T_j = 150$ °C			1.42	1.8	

1. Pulse test: $t_p = 5$ ms, $\delta < 2\%$
2. Pulse test: $t_p = 380$ µs, $\delta < 2\%$

To evaluate the conduction losses use the following equation:

$$P = 1.1 \times I_{F(AV)} + 0.023 I_{F(RMS)}^2$$

Table 5. Dynamic characteristics (per diode)

Symbol	Parameter	Test conditions		Min.	Typ.	Max.	Unit
t_{rr}	Reverse recovery time	$T_j = 25\text{ }^\circ\text{C}$	$I_F = 0.5\text{ A}, I_{rr} = 0.25\text{ A}, I_R = 1\text{ A}$			30	ns
			$I_F = 1\text{ A}, V_R = 30\text{ V}, dI_F/dt = 50\text{ A}/\mu\text{s}$		40	55	
I_{RM}	Reverse recovery current	$T_j = 125\text{ }^\circ\text{C}$	$I_F = 15\text{ A}, V_R = 400\text{ V}, dI_F/dt = 100\text{ A}/\mu\text{s}$		4	5.5	A
t_{fr}	Forward recovery time	$T_j = 25\text{ }^\circ\text{C}$	$I_F = 15\text{ A}, V_{FR} = 1.9\text{ V}, dI_F/dt = +100\text{ A}/\mu\text{s}$			100	ns
V_{FP}	Forward recovery voltage				2.5		V

Figure 1. Average forward power dissipation versus average forward current (per diode)

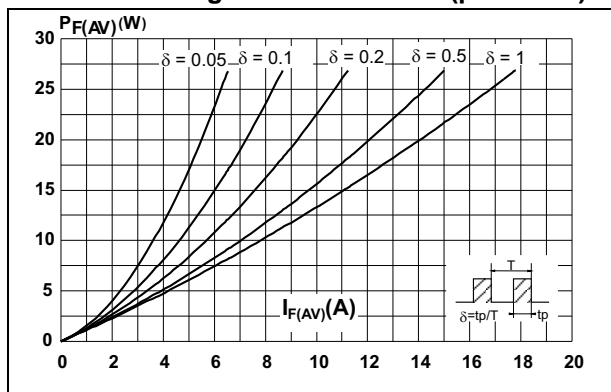

Figure 2. Forward voltage drop versus forward current (typical values, per diode)

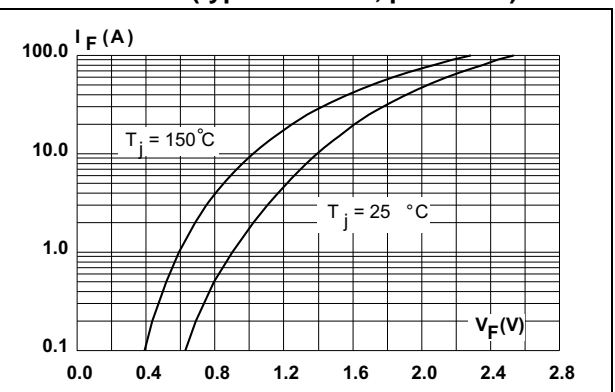

Figure 3. Forward voltage drop versus forward current (maximum values, per diode)

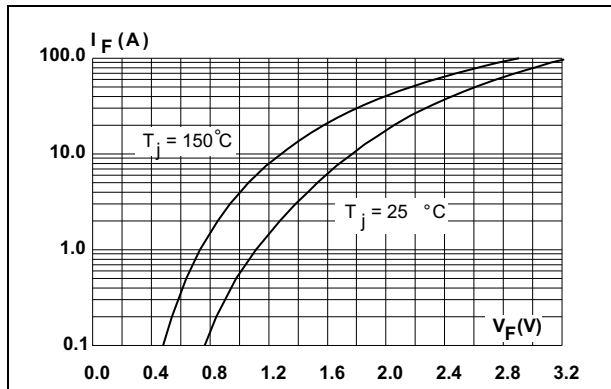

Figure 4. Relative variation of thermal impedance, junction to case, versus pulse duration (TO3P-3L, TO247 LL)

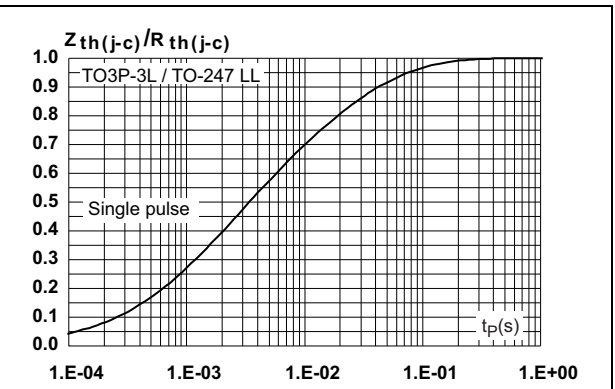

Figure 5. Relative variation of thermal impedance, junction to case, versus pulse duration (TO-3PF)

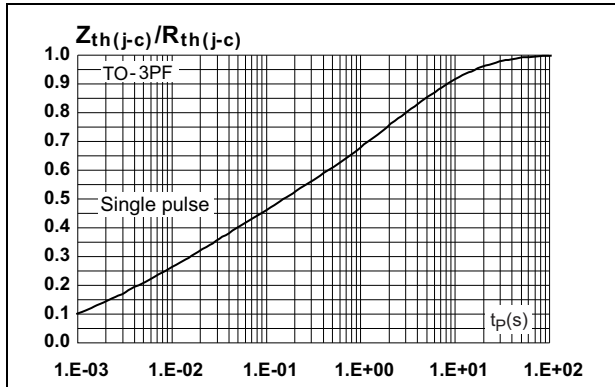

Figure 6. Peak reverse recovery current versus di_F/dt (typical values, per diode)

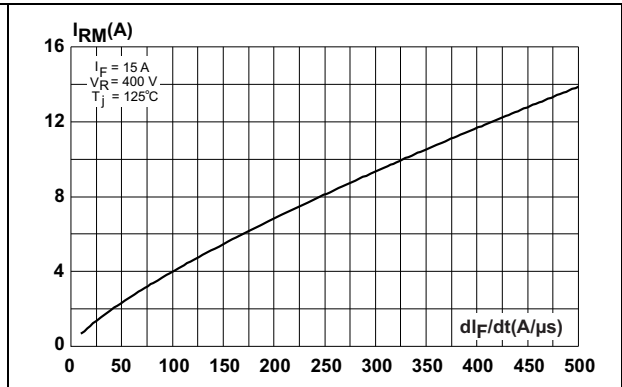

Figure 7. Reverse recovery time versus di_F/dt (typical values, per diode)

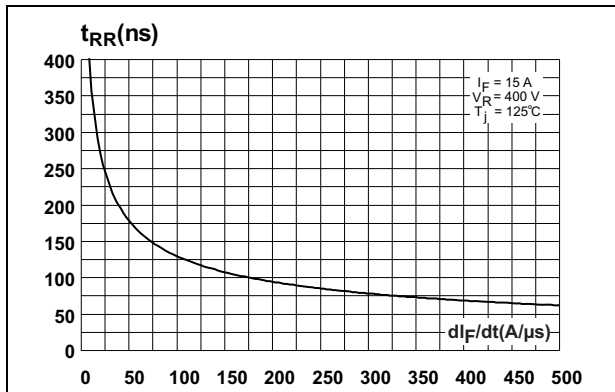

Figure 8. Reverse recovery charges versus di_F/dt (typical values, per diode)

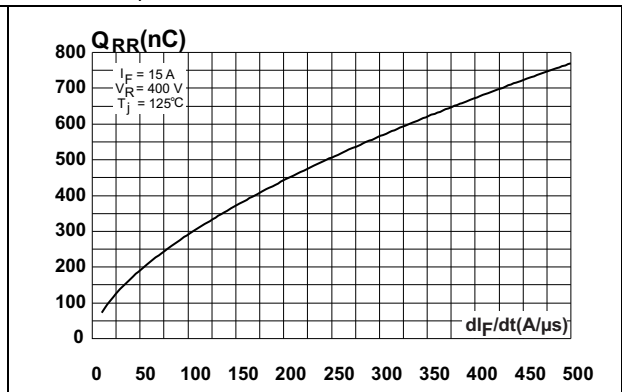

Figure 9. Reverse recovery softness factor versus di_F/dt (typical values, per diode)

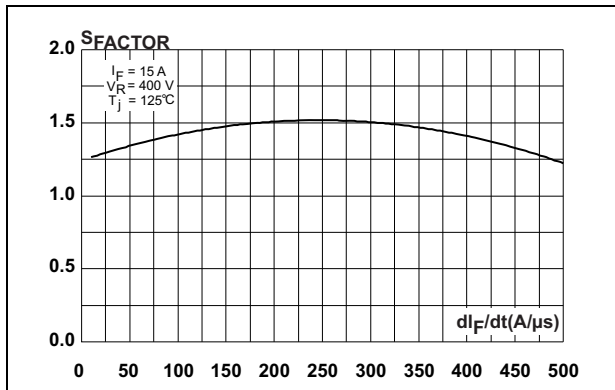

Figure 10. Relative variations of dynamic parameters versus junction temperature

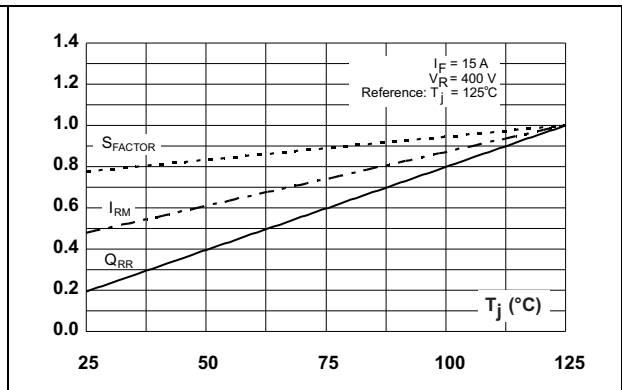

Figure 11. Transient peak forward voltage versus di_F/dt (typical values, per diode)

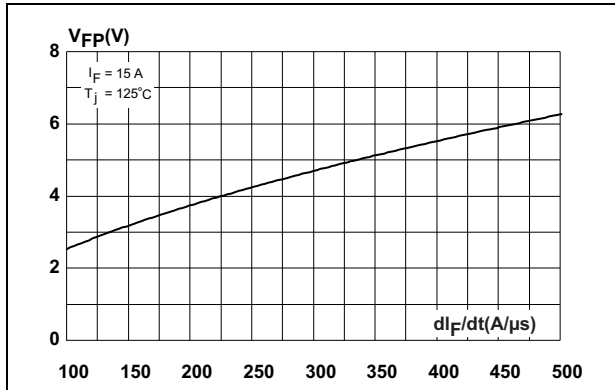

Figure 12. Forward recovery time versus di_F/dt (typical values, per diode)

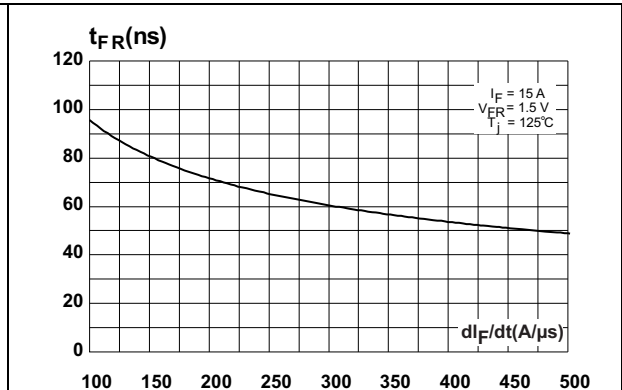
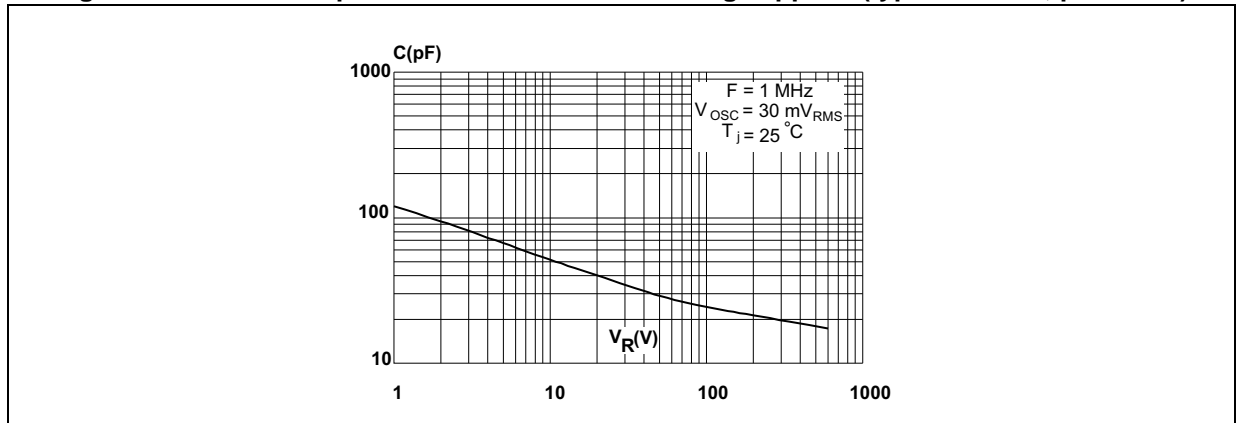

Figure 13. Junction capacitance versus reverse voltage applied (typical values, per diode)



2 Package information

- Epoxy meets UL94, V0
- Cooling method: by conduction (C)
- Recommended torque: 0.4 to 0.6 N·m
- Maximum torque value (T0-247 LL): 1.0 N·m

In order to meet environmental requirements, ST offers these devices in different grades of ECOPACK® packages, depending on their level of environmental compliance. ECOPACK® specifications, grade definitions and product status are available at: www.st.com. ECOPACK® is an ST trademark.

Figure 14. TO3P-3L dimension definitions

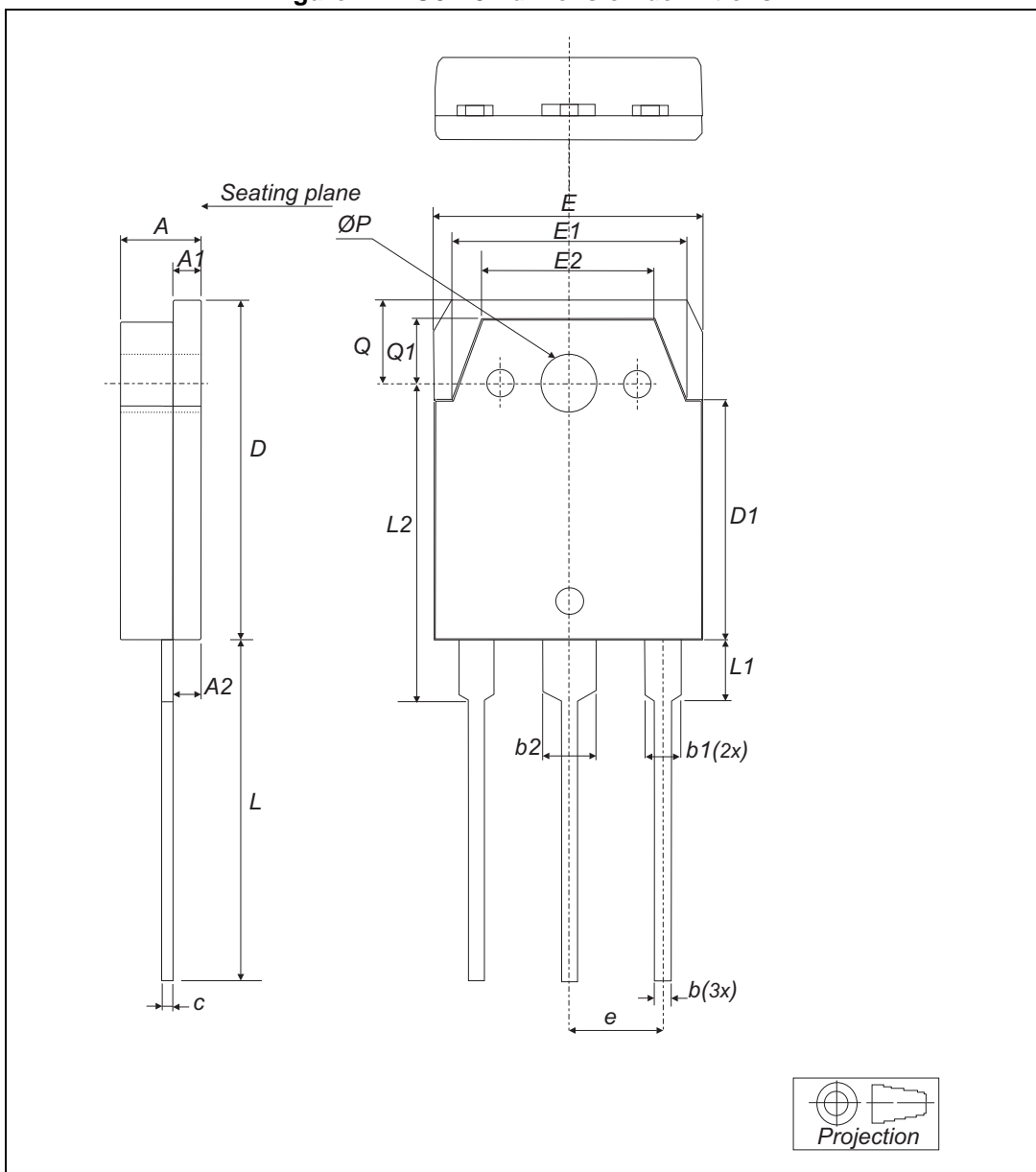

Table 6. TO3P-3L dimension values

Ref.	Dimensions					
	Millimeters			Inches		
	Min.	Typ.	Max.	Min.	Typ.	Max.
A	4.6		5	0.18		0.19
A1	1.45	1.5	1.65	0.05	0.06	0.06
A2	1.20	1.40	1.60	0.04	0.05	0.06
b	0.80	1	1.20	0.03	0.04	0.05
b1	1.80		2.20	0.07		0.08
b2	2.80		3.20	0.11		0.12
c	0.55	0.60	0.75	0.02	0.02	0.03
D	19.70	19.90	20.10	0.77	0.78	0.79
D1		13.90			0.54	
E	15.40		15.80	0.60		0.62
E1		13.60			0.53	
E2		9.60			0.38	
e	5.15	5.45	5.75	0.20	0.21	0.22
L	19.50	20	20.50	0.76	0.78	0.80
L1		3.50			0.14	
L2	18.20	18.40	18.60	0.71	0.72	0.73
ØP	3.10		3.30	0.12		0.13
Q		5			0.19	
Q1		3.80			0.15	

Figure 15. TO-3PF dimension definitions

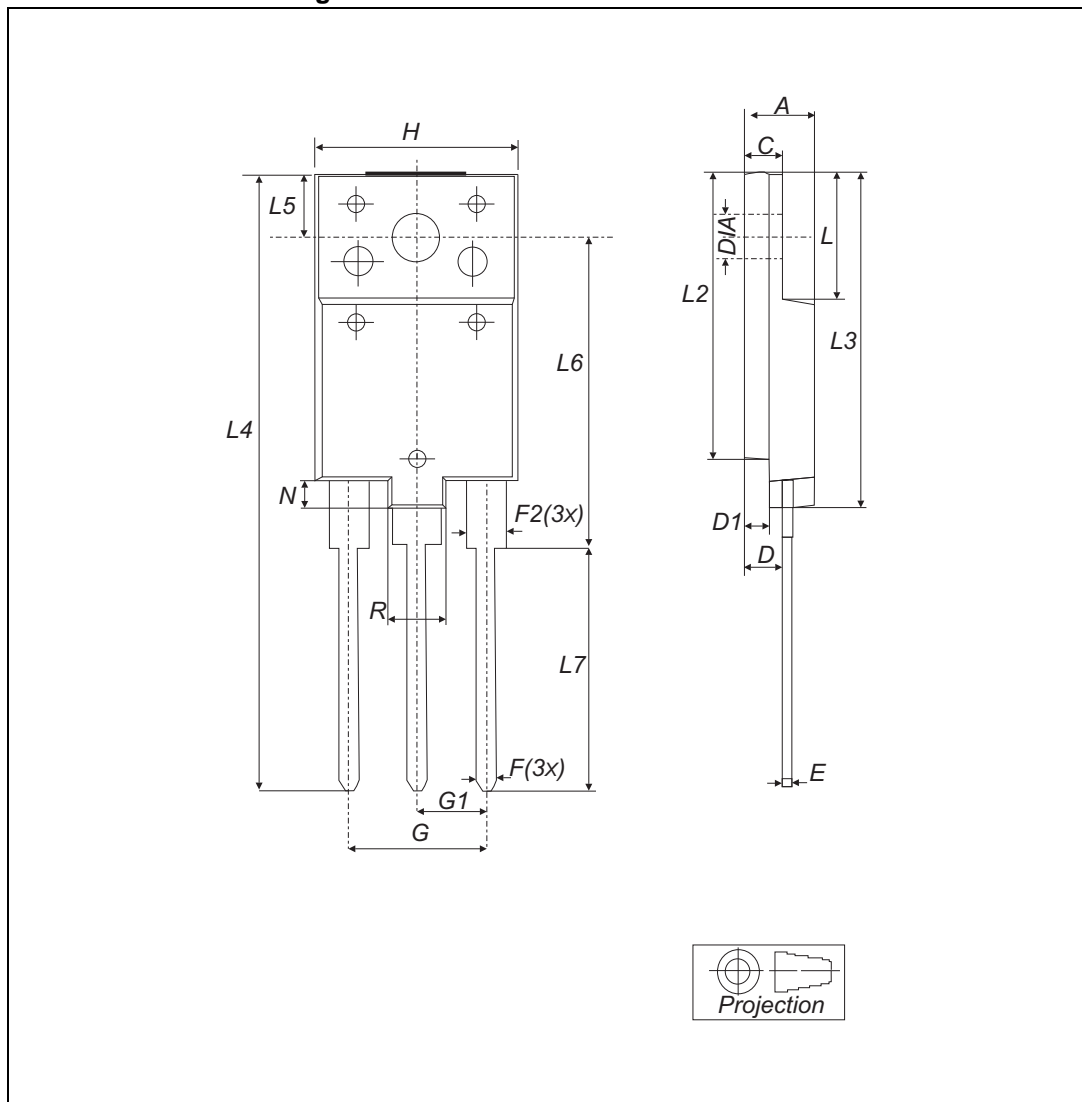

Table 7. TO-3PF dimension values

Ref.	Dimensions					
	Millimeters			Inches		
	Min.	Typ.	Max.	Min.	Typ.	Max.
A	5.30		5.70	0.2		0.22
C	2.80		3.20	0.11		0.12
D	3.10		3.50	0.12		0.13
D1	1.80		2.20	0.07		0.08
E	0.80		1.10	0.03		0.04
F	0.65		0.95	0.025		0.037
F2	1.80		2.20	0.07		0.08
G	10.30		11.50	0.40		0.45
G1		5.45			0.21	
H	15.30		15.70	0.60		0.61
L	9.80	10	10.20	0.38	0.39	0.40
L2	22.20		22.80	0.87		0.90
L3	26.30		26.70	1.03		1.05
L4	43.20		44.40	1.70		1.74
L5	4.30		4.70	0.16		1.18
L6	24.30		24.70	0.95		0.97
L7	14.60		15	0.57		0.59
N	1.80		2.20	0.07		0.08
R	3.80		4.20	0.14		0.16
Dia	3.40		3.80	0.13		0.15

Figure 16. TO-247 LL dimension definitions

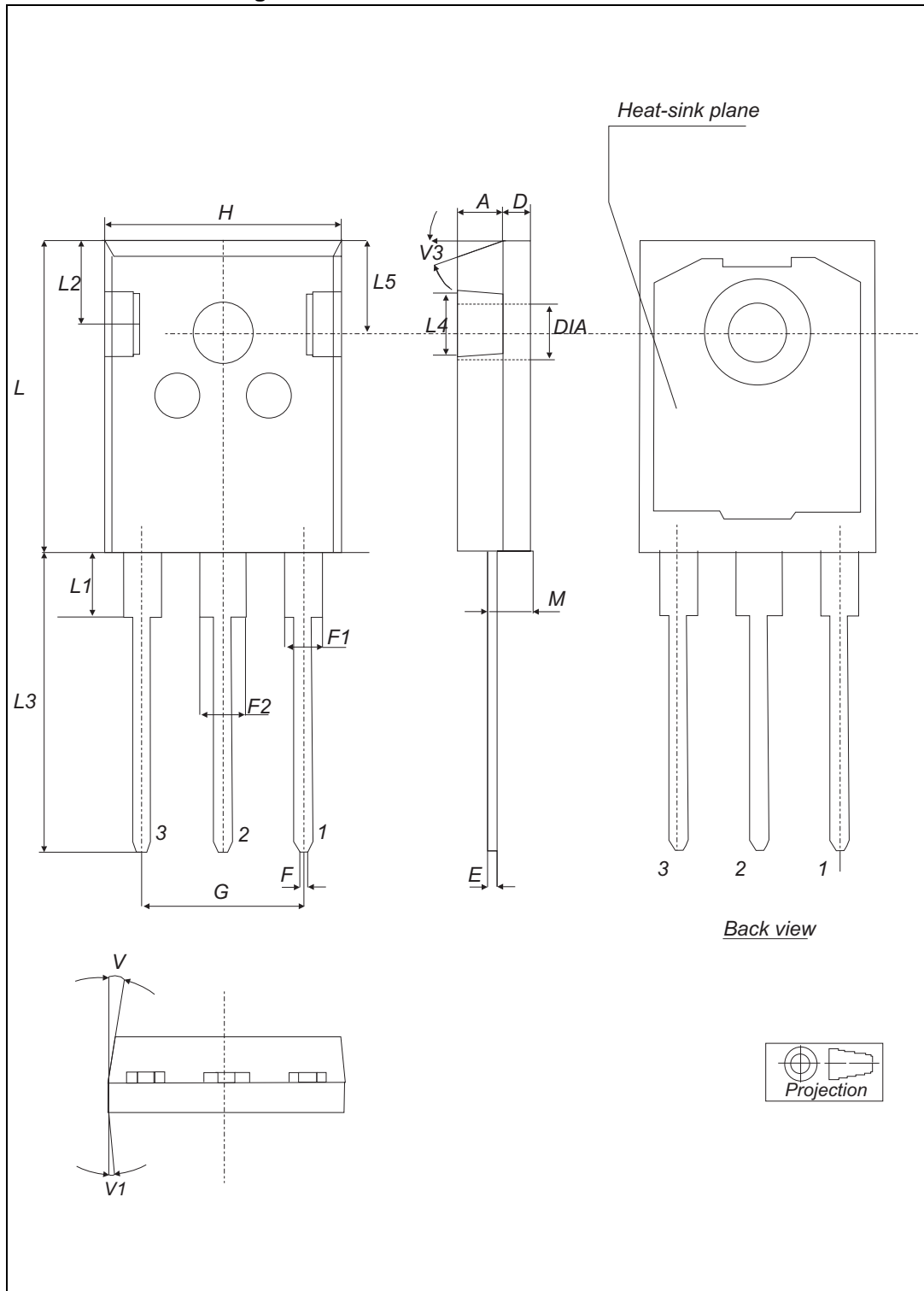

Table 8. TO-247 LL dimension values

Ref.	Dimensions					
	Millimeters			Inches		
	Min.	Typ.	Max.	Min.	Typ	Max.
A	4.90		5.15	0.192		0.202
D	1.85		2.10	0.072		0.082
E	0.55		0.67	0.021		0.026
F	1.07		1.32	0.042		0.051
F1	1.90		2.38	0.074		0.093
F2	2.87		3.38	0.11		0.133
G	10.90 BSC			0.429 BSC		
H	15.77		16.02	0.62		0.63
L	20.82		21.07	0.81		0.82
L1	4.16		4.47	0.163		0.175
L2	5.49		5.74	0.216		0.225
L3	20.05		20.30	0.789		0.799
L4	3.68		3.93	0.144		0.154
L5	6.04		6.29	0.237		0.247
M	2.25		2.55	0.088		0.10
V		10°			10°	
V1		3°			3°	
V3		20°			20°	
∅	3.55		3.66	0.139		0.143

3 Ordering information

Table 9. Ordering information

Order code	Marking	Package	Weight	Base qty	Delivery mode
STTH30AC06CP	STTH30AC06CP	TO3P-3L	5.26	30	Tube
STTH30AC06CPF	TH30AC06C	TO-3PF	5.6	30	Tube
STTH30AC06CWL	STTH30AC06CWL	TO-247 LL	4.36	30	Tube

4 Revision history

Table 10. Document revision history

Date	Revision	Changes
13-Nov-2013	1	First release.

Please Read Carefully:

Information in this document is provided solely in connection with ST products. STMicroelectronics NV and its subsidiaries ("ST") reserve the right to make changes, corrections, modifications or improvements, to this document, and the products and services described herein at any time, without notice.

All ST products are sold pursuant to ST's terms and conditions of sale.

Purchasers are solely responsible for the choice, selection and use of the ST products and services described herein, and ST assumes no liability whatsoever relating to the choice, selection or use of the ST products and services described herein.

No license, express or implied, by estoppel or otherwise, to any intellectual property rights is granted under this document. If any part of this document refers to any third party products or services it shall not be deemed a license grant by ST for the use of such third party products or services, or any intellectual property contained therein or considered as a warranty covering the use in any manner whatsoever of such third party products or services or any intellectual property contained therein.

UNLESS OTHERWISE SET FORTH IN ST'S TERMS AND CONDITIONS OF SALE ST DISCLAIMS ANY EXPRESS OR IMPLIED WARRANTY WITH RESPECT TO THE USE AND/OR SALE OF ST PRODUCTS INCLUDING WITHOUT LIMITATION IMPLIED WARRANTIES OF MERCHANTABILITY, FITNESS FOR A PARTICULAR PURPOSE (AND THEIR EQUIVALENTS UNDER THE LAWS OF ANY JURISDICTION), OR INFRINGEMENT OF ANY PATENT, COPYRIGHT OR OTHER INTELLECTUAL PROPERTY RIGHT.

ST PRODUCTS ARE NOT DESIGNED OR AUTHORIZED FOR USE IN: (A) SAFETY CRITICAL APPLICATIONS SUCH AS LIFE SUPPORTING, ACTIVE IMPLANTED DEVICES OR SYSTEMS WITH PRODUCT FUNCTIONAL SAFETY REQUIREMENTS; (B) AERONAUTIC APPLICATIONS; (C) AUTOMOTIVE APPLICATIONS OR ENVIRONMENTS, AND/OR (D) AEROSPACE APPLICATIONS OR ENVIRONMENTS. WHERE ST PRODUCTS ARE NOT DESIGNED FOR SUCH USE, THE PURCHASER SHALL USE PRODUCTS AT PURCHASER'S SOLE RISK, EVEN IF ST HAS BEEN INFORMED IN WRITING OF SUCH USAGE, UNLESS A PRODUCT IS EXPRESSLY DESIGNATED BY ST AS BEING INTENDED FOR "AUTOMOTIVE, AUTOMOTIVE SAFETY OR MEDICAL" INDUSTRY DOMAINS ACCORDING TO ST PRODUCT DESIGN SPECIFICATIONS. PRODUCTS FORMALLY ESCC, QML OR JAN QUALIFIED ARE DEEMED SUITABLE FOR USE IN AEROSPACE BY THE CORRESPONDING GOVERNMENTAL AGENCY.

Resale of ST products with provisions different from the statements and/or technical features set forth in this document shall immediately void any warranty granted by ST for the ST product or service described herein and shall not create or extend in any manner whatsoever, any liability of ST.

ST and the ST logo are trademarks or registered trademarks of ST in various countries.

Information in this document supersedes and replaces all information previously supplied.

The ST logo is a registered trademark of STMicroelectronics. All other names are the property of their respective owners.

© 2013 STMicroelectronics - All rights reserved

STMicroelectronics group of companies

Australia - Belgium - Brazil - Canada - China - Czech Republic - Finland - France - Germany - Hong Kong - India - Israel - Italy - Japan - Malaysia - Malta - Morocco - Philippines - Singapore - Spain - Sweden - Switzerland - United Kingdom - United States of America

www.st.com